

5 Installation

This chapter provides information on the site requirements for your TB9300 equipment and also describes how to install the base station in a standard 19 inch rack or cabinet.

If this is your first time installing a TB9300 base station, we recommend that you read the entire chapter before beginning the actual installation.

5.1 Before You Begin

5.1.1 Equipment Security

The security of your base station equipment is a high priority. If the site is not fully secure, the base station should at least be locked in a secure cabinet to prevent unauthorized access.

5.1.2 Grounding and Lightning Protection

Electrical Ground The base station modules are grounded by physical contact between the module case and the subrack. To ensure a good ground connection you must tighten each module retaining clamp securely (refer to [“Final Reassembly” on page 102](#) for the correct torque).

A threaded grounding connector is provided on the rear of the subrack for connection to the site ground point (refer to [“Connecting Up the Base Station” on page 79](#) for more details).

Lightning Ground It is extremely important for the security of the site and its equipment that you take adequate precautions against lightning strike. Because it is outside the scope of this manual to provide comprehensive information on this subject, we recommend that you conform to your country’s standards organization or regulatory body.

5.1.3 Equipment Ventilation

Always ensure there is adequate ventilation around the base station.

Notice **Do not** operate it in a sealed cabinet. You **must** keep the ambient temperature within the specified range, and we **strongly** recommended that you ensure that the cooling airflow is not restricted.

Notice The cooling fans are mounted on the front panel and will only operate when the panel is fitted correctly to the front of the subrack. To ensure adequate airflow through the base station, do not operate it for more than a few minutes with the front panel removed (e.g. for servicing purposes).

5.1.4 Ambient Temperature Sensor

The ambient temperature reading for the base station is provided by the temperature sensor located on the front panel circuit board.

5.1.5 Cabinet and Rack Ventilation

The cooling airflow for the base station enters through the front panel and exits at the rear of the subrack. For optimum thermal performance, the heated air that has passed through a base station must not be allowed to re-enter the air intakes on the front panel. Any space at the front of the cabinet not occupied by equipment should be covered by a blanking panel. Refer to [Figure 5.1 on page 64](#).

To allow enough cooling airflow through a cabinet-mounted base station, we recommend the following:

- an area of at least 23 in² (150 cm²) of unrestricted ventilation slots or holes in front of the air intakes for the fans for each subrack; for example, thirty 0.25 x 3.3 in (6 x 85 mm) slots will allow the recommended airflow
- a vent in the top of the cabinet with an area of approximately 23 in² (150 cm²) per subrack, or a similar area of ventilation per subrack at the rear of the cabinet behind each subrack
- a 2U gap at the top of the cabinet.

Notice The ventilation opening must be unrestricted. If the slots or holes are covered with a filter, mesh or grille, the open area must be increased to allow the same airflow as an unrestricted opening.

The maximum ambient temperature entering the cabinet must not exceed +140°F (+60°C).

If you are installing multiple subracks in a cabinet, ensure that there will be enough cooling airflow through the cabinet after the equipment has been installed. For example, the recommended maximum number of subracks in a 38 U cabinet is five, as shown in [Figure 5.1 on page 64](#).

If the base station is installed in a rack or cabinet with other equipment with different ventilation requirements, we recommend that the base station be positioned below this equipment.

Auxiliary Extractor Fans

The base station does not require auxiliary extractor fans mounted in the top of the cabinet. If your cabinet is already fitted with fans, the following procedures apply:

- if there are six or more 4.75 in (12 cm) fans, each capable of extracting 94.2 ft³ per minute (160 m³ per hour), they must run continuously
- if there are fewer than six fans, you must remove them and ensure the vent in the top of the cabinet has an area of approximately 23 in² (150 cm²) per subrack.

If you have any other configuration, the performance of your system will depend on how closely you comply with the base station airflow requirements described above.

Figure 5.1 Typical cabinet ventilation requirements

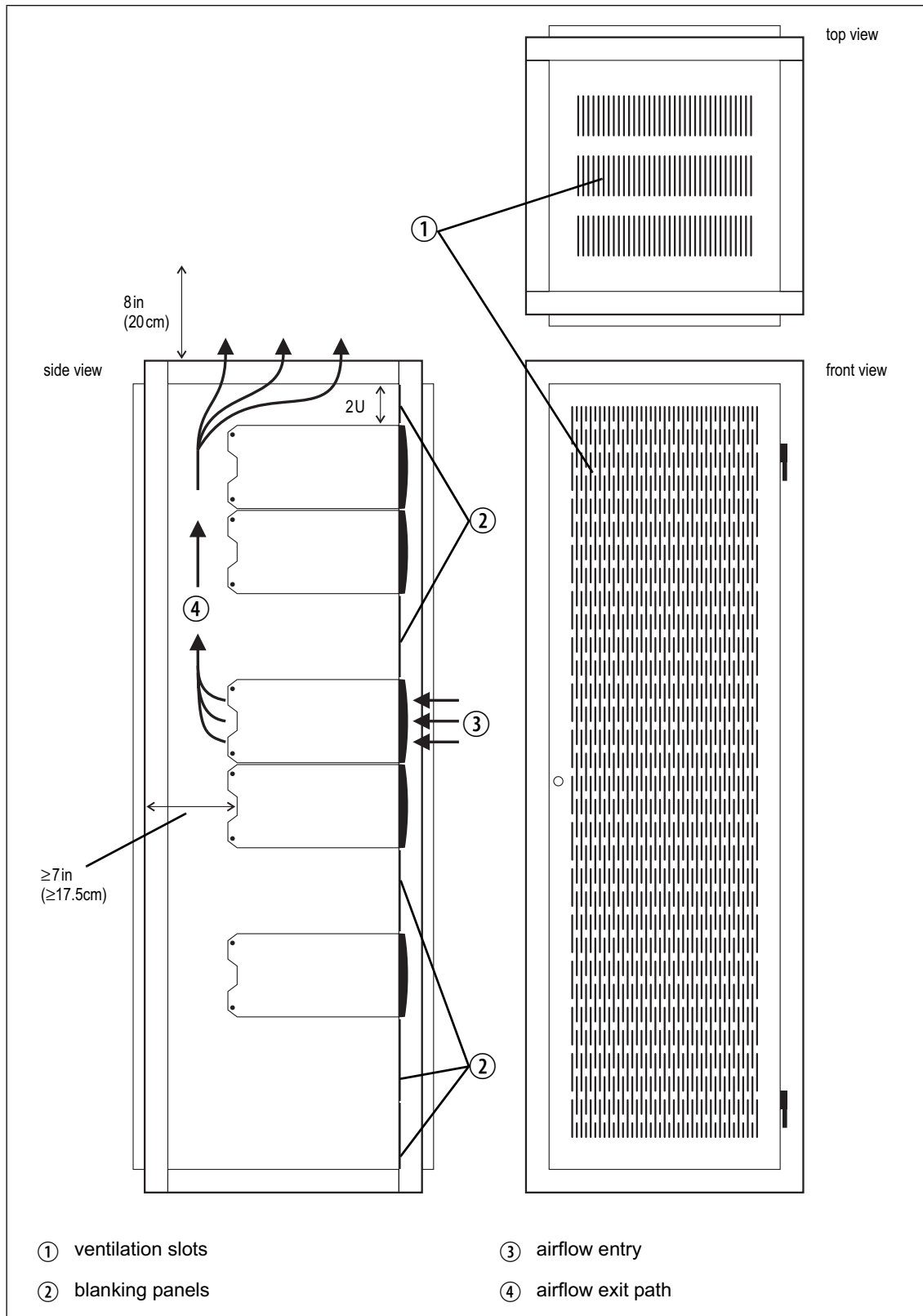

5.2 Unpacking and Moving the Subrack

The subrack is packed in a strong corrugated cardboard carton with top and bottom foam cushions. To prevent personal injury and damage to the equipment, we recommend that two people unpack and move the subrack. To remove the subrack from the carton, follow the procedure illustrated in [Figure 5.2](#).



Caution A subrack complete with modules can weigh up to 62 lb (28 kg), or up to 66 lb (30 kg) complete with packaging. We recommend that you have another person help you unpack and move the equipment. The TBAA03-16 carrying handles will make it easier to move the equipment once it has been unpacked. If necessary, remove the modules from the subrack before moving it (refer to [“Replacing Modules” on page 91](#)). In all cases follow safe lifting practices.

Figure 5.2 Unpacking the subrack

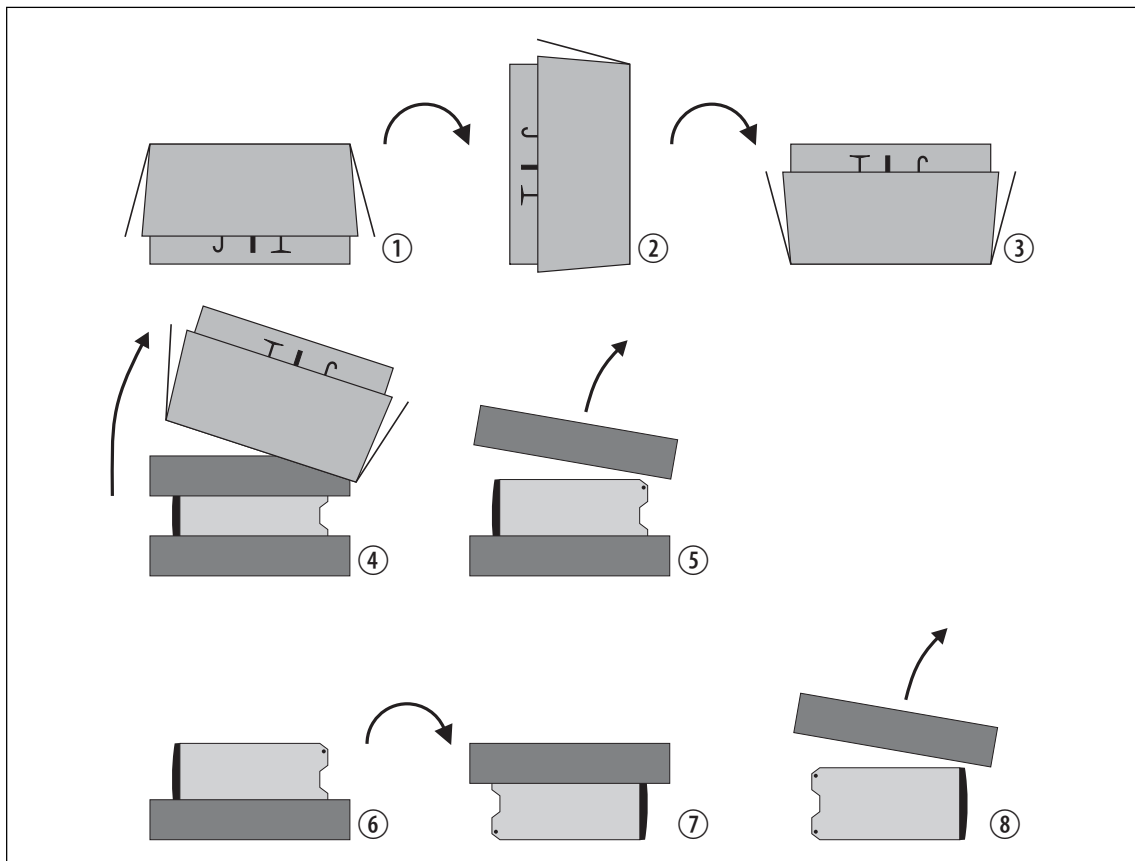

1. Cut the tape securing the flaps at the top of the carton and fold them flat against the sides ①.
2. Rotate the carton carefully onto its side ② and then onto its top ③, ensuring that none of the flaps is trapped underneath.

3. Slide the carton upwards over the foam cushions and lift it away ④. Remove the cushion from the bottom of the subrack ⑤.
4. Rotate the subrack and cushion carefully over the rear of the subrack ⑥ so that it is the right way up with the cushion on top ⑦. Remove the cushion from the top of the subrack ⑧.

Disposal of Packaging

If you do not need to keep the packaging, we recommend that you recycle it according to your local recycling methods. The foam cushions are CFC- and HCFC-free and may be burnt in a suitable waste-to-energy combustion facility, or compacted in landfill.

5.3 Identifying the Equipment

You can identify the model and hardware configuration of the TB9300 modules by referring to the product code printed on labels at the rear of each module. The meaning of each character in the product code is explained in the tables below.

-  This explanation of product codes is not intended to suggest that any combination of features is necessarily available in any one product. Consult your regional Tait office for more information regarding the availability of specific models and options.

Reciter Product Codes

Product Code	Description
T01-01103-XXXX	Frequency Band and Sub-band D = 148MHz to 174MHz (B3)
T01-01103-XXXX	A = standard
T01-01103-XXXX	A = default
T01-01103-XXXX	A = default

PA Product Codes

Product Code	Description
TBAXXXX-XXXX	8 = 50W 9 = 100W
TBAXXX-XXXX	0 = default
TBAXXX-XXXX	Frequency Band and Sub-band B1 = 136MHz to 174MHz
TBAXXXX-XXXX	0 = default
TBAXXXX-XXXX	0 = default
TBAXXXX-XXXX	0 = default
TBAXXXX-XXXX	1 = default

PMU Product Codes

Product Code	Description
TBA X XXX-XXXX	3 = PMU
TBA3 X XX-XXXX	0 = default
TBA3X X X-XXXX	0 = AC module not fitted A = AC module fitted
TBA3XX X -XXXX	0 = DC module not fitted 1 = 12V DC module fitted 2 = 24V DC module fitted 4 = 48V DC module fitted
TBA3XXX- X XXX	0 = standby power supply card not fitted 1 = 12VDC standby power supply card fitted 2 = 24VDC standby power supply card fitted 4 = 48VDC standby power supply card fitted
TBA3XXX-X X XX	0 = auxiliary power supply board not fitted 1 = 12VDC auxiliary power supply board fitted 2 = 24VDC auxiliary power supply board fitted 4 = 48VDC auxiliary power supply board fitted
TBA3XXX-XX X X	0 = default
TBA3XXX-XXX X	0 = default

5.4 Initial Setting Up

Before putting the base station into service, you may want to carry out some basic functional testing, configuration, and tuning (if required). This section provides an overview of these procedures:

- checking that the base station powers up correctly
- checking the basic functionality of the base station by using the tests available in the web interface
- customizing the configuration for the intended installation and verifying that the configuration is correct
- changing the root password
- tuning the base station (if required).

5.4.1 Confirming Operation

Notice Make sure that the RF output is connected to a suitable attenuator or dummy load. Do not remove the load while the PA is transmitting as this may damage the PA output stage.

- Applying Power**
1. Apply power by turning on the PMU.
 2. Check that the base station powers up correctly:
 - The front panel display will show “Please wait...” while the base station starts up (this may take up to two minutes). When the startup process is complete, the display will show the home screen.
 - The cooling fans in the front panel will run at full speed for a few seconds, then run at low speed while the base station starts up, and then assume standard operation. One or more fans may operate, depending on the temperature of the modules.

Functional Tests

The following table provides an overview of the tests available using the web interface. Refer to the Help for full details of these tests.

Test	Notes	Menu
receiver operation	requires a suitable RF source	Diagnose > RF Interface > Receiver
transmitter operation	requires connection to the network	Diagnose > RF Interface > Transmitter
ping	checks the IP connection to another device with an IP address	Diagnose > Connection > Network
NTP query	checks if the NTP-based time synchronization is working	
PMU mains failure	requires a DC backup supply	Diagnose > Subsystems > PMU Control Tests
fan operation	checks the operation of each fan individually	Diagnose > Subsystems > Fan Tests

5.4.2 Customizing the Configuration

The following steps provide an overview of the process used to configure the base station with the settings it needs. Refer to the Help for detailed information.

1. Log in to the base station (refer to [“Connecting Your PC to the Base Station” on page 46](#) for more details).
2. Select Configure. The base station has many different settings that can be configured before it is put into operation, such as:
 - channel configurations
 - alarm control and SNMP agent
 - network interfaces
 - quality of service
 - CWID
 - miscellaneous items such as minimum battery voltages, fan control, NTP and package servers.
3. Make the changes needed in each form and click **Save**.

We recommend that you save the configuration to your PC or network. First make a backup copy of the configuration (which is stored in the base station as a file), then save this file to a folder on your PC or network. This provides a backup which can be restored to the base station if the configuration information becomes lost or corrupted.

5.4.3 Changing the Root Password

The root password to the Linux operating system of the reciter is a possible security risk. The equipment is delivered with a default password that is well known. Knowledge of the password could be used to render the equipment inoperable, for example by deleting files. If you are concerned about the security risk that this poses, change the password. If Tait provides support services, it may need to know the password.

Notice If you change the password and then lose it, the equipment must be returned to Tait. Make sure that you store the password securely and do not lose it.

To change the root password, follow these steps.

1. Log in from your PC to the base station using SSH client software such as PuTTY. The username is “root” and the default password is “k1w1”.
2. At the # prompt, enter the command “passwd”.
3. Follow the on-screen instructions.
4. Record the password in a secure location.

5.4.4 Tuning the Reciter

Before the base station is installed on site, you may need to tune the receiver front end. The receiver front end requires tuning if the receive frequency is shifted more than 2MHz away from the previously set frequency, or the RSSI level of the new frequency is more than 1 dB lower than the RSSI level of the previously set frequency.

The receiver in the B3-band VHF reciter covers the 148 to 174MHz frequency band. This is split into two sub-bands: 148 to 159MHz and 159 to 174MHz. Each sub-band has its own helical filter which is electronically switched in or out of circuit depending on the frequency programmed into the reciter. The bandwidth of these helical filters is approximately ± 1.5 MHz.

To check the RSSI level and tune the receiver front end (if required), follow these steps.

1. Log in to the reciter and select Monitor > Interfaces > RF Interface.
2. Feed a signal at the currently tuned receive frequency and at a level of -80 dBm into the reciter’s RF input. Check that the RSSI reading on the RF Interface page is -80 dBm ± 1 dB. Note this reading.
3. Set the reciter to the new receive frequency.

4. Change the RF input signal to the new receive frequency at -80dBm . Check that the RSSI reading is $-80\text{dBm} \pm 1\text{dB}$. If it is, the receiver front end does not require tuning. If it is not, go to the next step.
5. Using the Johanson tuning tool¹, adjust the correct helical filter for the new frequency (as shown below) to obtain a peak RSSI reading. This reading should be within 1 dB of the reading at the previous frequency.

Adjust the center resonator of the filter first, followed by the two outer resonators (in any order). Each resonator should require approximately the same amount of adjustment when tuning.

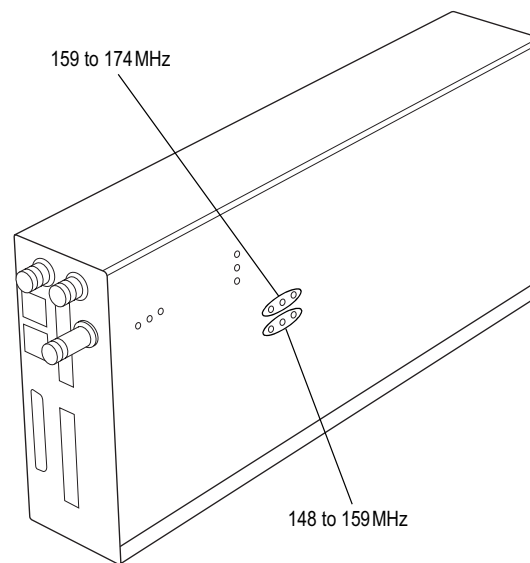

- i** A change in frequency of 5 MHz requires approximately one turn of the tuning slug. If tuning to a lower frequency, adjust the slug in (clockwise); for a higher frequency, adjust the slug out (counterclockwise).
6. Change the RF input signal and the reciter's receive frequency to 0.5 MHz above and below the required frequency and check that the RSSI reading does not drop by more than 0.5 dB from the reading at the required frequency.
 7. Recalibrate the RSSI at the new frequency (Calibrate > Reciter > RSSI).
- i** If you wish to confirm the accuracy of the tuning procedure, carry out a sensitivity measurement at the new frequency.

1. Included in the TBA0ST2 tool kit. Also available separately as part number 937-00013-00.

5.5 Installing the Base Station on Site

5.5.1 Base Stations for Trunked Systems

When installing base stations that are part of a trunked system, it is very important to observe good site engineering rules. This is especially true when the channels are combined into a single antenna, particularly if the receivers and transmitters also share the antenna, as in a duplexed system.

If at all possible, the RF planner should avoid frequency plans in which the Rx to Tx spacing is an exact multiple of the trunked channel spacing, thus forcing Tx intermodulation products to fall outside the Rx channels.

Cables and antennas should be of high quality construction. Solid shield heliax type cables are best, but if braided shield cables must be used for short distances, their braids must be silver-plated. Isolators should be used at all transmitter outputs.

When the outputs of more than one transmitter are combined, their voltages add, and the resulting peak envelope power is not simply the sum of their powers, but is equal to the power of one of them multiplied by the square of the number of sources. Cables, components, and hardware must be rated to withstand the peak envelope power.

During the commissioning process, all transmitters should be activated together using a diagnostic test tone, while the receiver RSSI is monitored. There should be no perceptible increase in RSSI while the transmitters are active.

5.5.2 Equipment Required

It is beyond the scope of this manual to list every piece of equipment that an installation technician should carry. However, the following tools are specifically required for installing the base station:

- Pozidriv PZ3 screwdriver for the M6 screws used in the DC input terminals on the PMU; M6 (0.25 in) screws are also used to secure the subrack to the cabinet in factory-assembled systems
- Pozidriv PZ2 screwdriver for the M4 screws used to secure the module retaining clamps, and for the fasteners used to secure the front panel to the subrack
- 8mm AF spanner for the SMA connectors, and the subrack ground connector.

You can also obtain the TBA0ST2 tool kit from your regional Tait office. It contains the basic tools needed to install, tune, and service the base station.

5.5.3 Mounting the Subrack



Caution A subrack complete with modules can weigh up to 62lb (28kg), or up to 66lb (30kg) complete with packaging. We recommend that you have another person help you unpack and move the equipment. The TBAA03-16 carrying handles will make it easier to move the equipment once it has been unpacked. If necessary, remove the modules from the subrack before moving it (refer to “[Replacing Modules](#)” on [page 91](#)). In all cases follow safe lifting practices.

Figure 5.3 Subrack mounting points

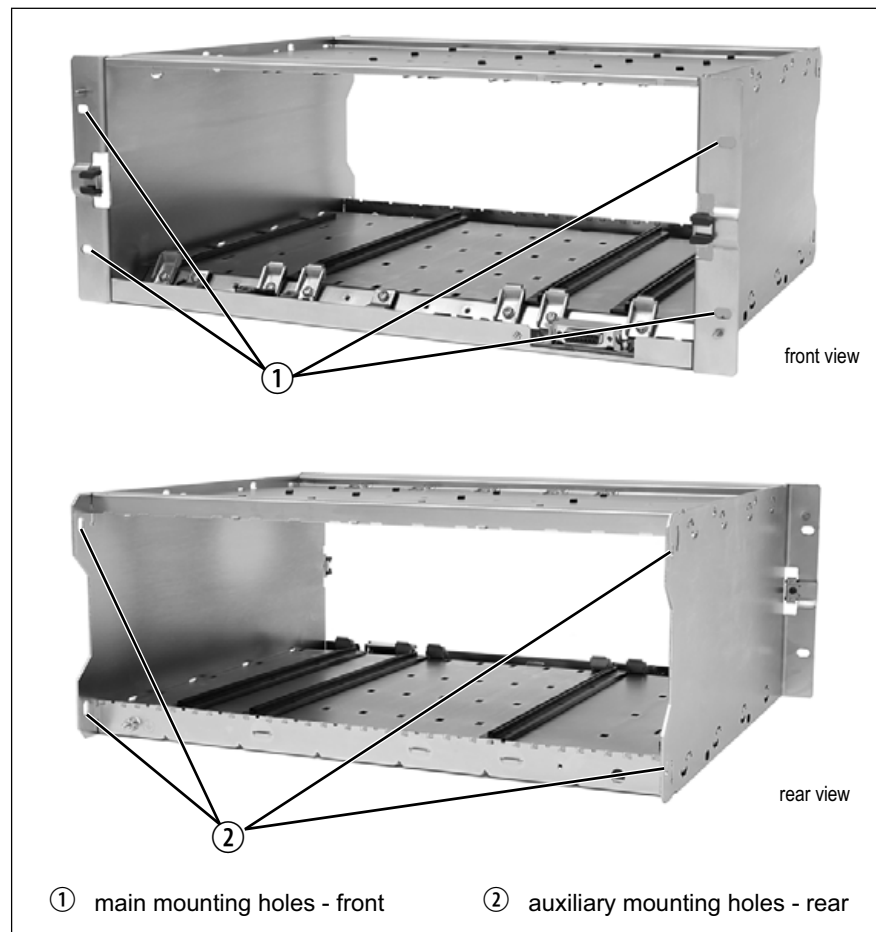

1. Remove the front panel, as described in “[Preliminary Disassembly](#)” on [page 93](#).
2. Fit the subrack into the cabinet or rack and secure it firmly with an M6 (0.25in) screw, flat and spring washer in each of the four main mounting holes ①, as shown in [Figure 5.3](#).

i If you need extra mounting security, additional mounting holes ② are provided at the rear of the subrack for auxiliary support brackets.

Figure 5.4 below gives the dimensions of the subrack and its mounting holes.

Figure 5.4 Subrack dimensions

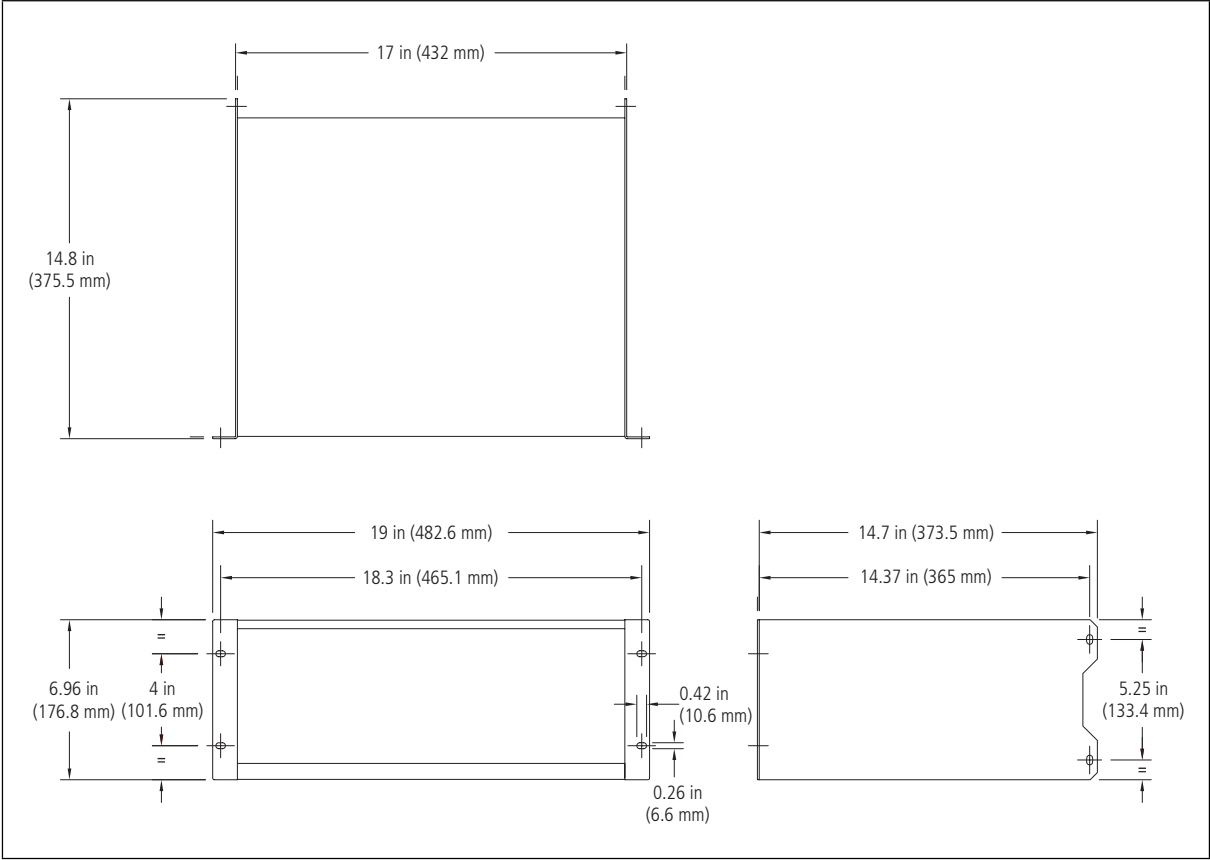

Auxiliary Support Bracket

TBAA03-13 auxiliary support brackets can be fitted to the rear of the subrack to provide additional mounting security. Figure 5.5 shows a standard TBAA03-13 bracket ① fitted in a typical Tait cabinet ②. If you are not using the Tait cabinet, you may have to make your own brackets to suit your installation.

Figure 5.5 Auxiliary support bracket

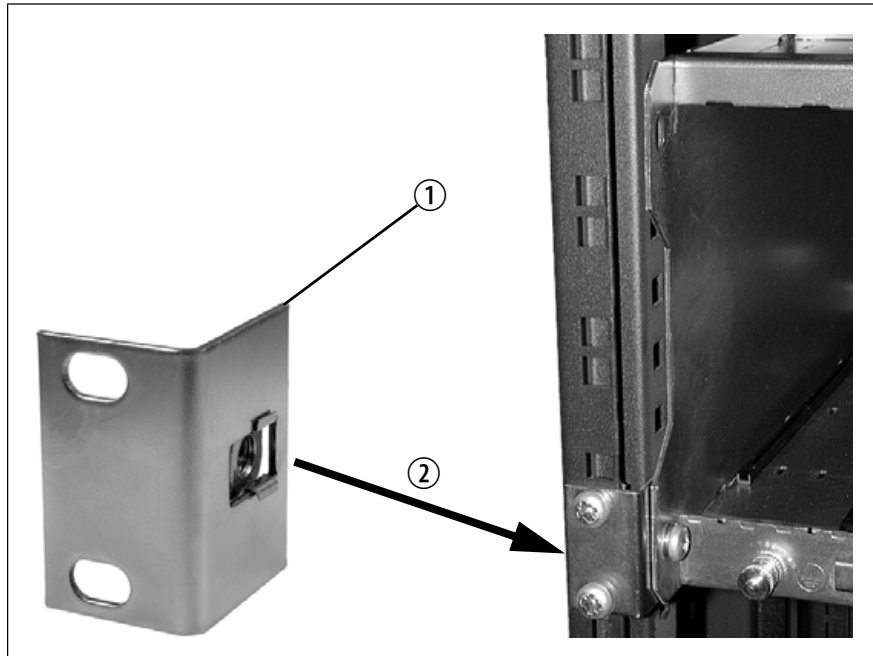

Notice You **must** fit the auxiliary support brackets if you intend to transport a cabinet fitted with a fully built-up base station.

We also recommend that you fit the brackets under the following conditions:

- when the installation is in an area prone to earthquakes
- when third party equipment is installed hard up underneath the base station subrack.

General Cabling

We recommend that you try to route all cables to and from the base station along the side of the cabinet so the cooling airflow is not restricted.

DC Power Cabling

DC power cables should be well supported so that the terminals on the PMU and on the ends of the cables do not have to support the full weight of the cables.

Figure 5.6 shows two recommended methods of securing these cables to prevent straining either set of terminals.

We recommend that you fit the supplied covers to the DC terminals to protect against accidental shorts.

Figure 5.6 DC power cabling

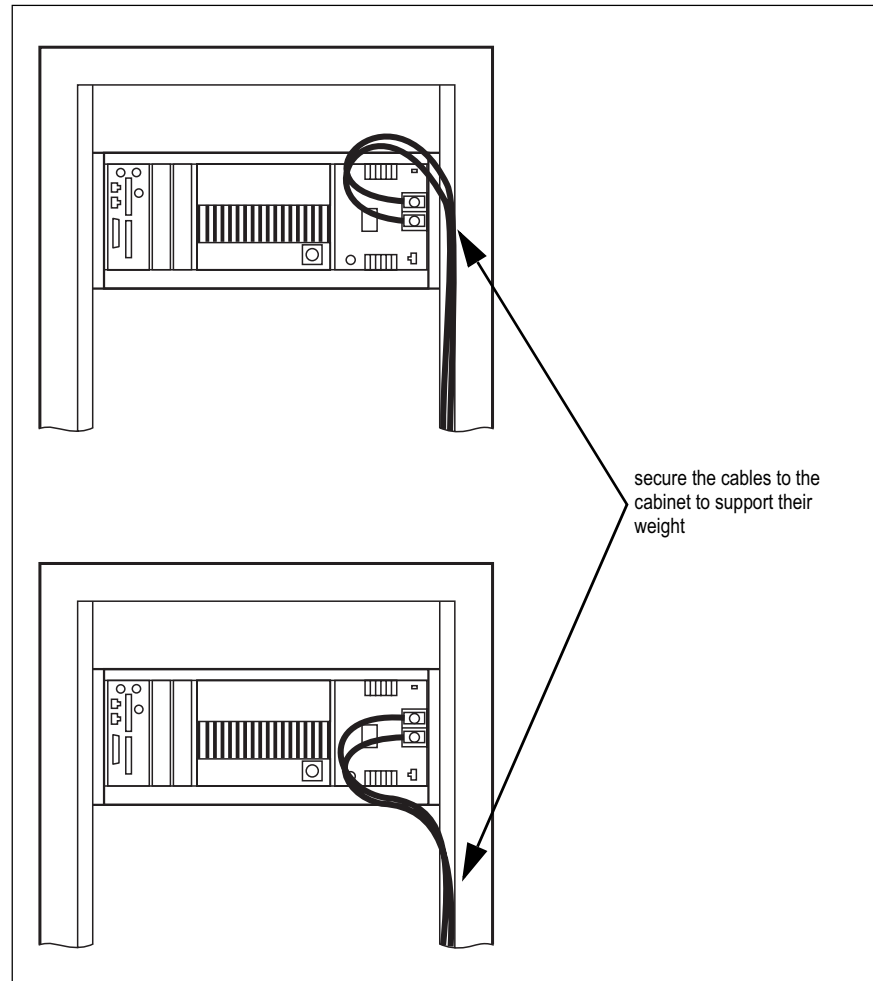

5.6 Connecting Up the Base Station

This section provides information relevant to the task of connecting up the various inputs and outputs of the base station.

5.6.1 Connection Overview

The connections at the rear of a dual 50 W base station are identified in [Figure 5.7](#). External connections are all located at the rear of the subrack.

Figure 5.7 50W base station inputs and outputs

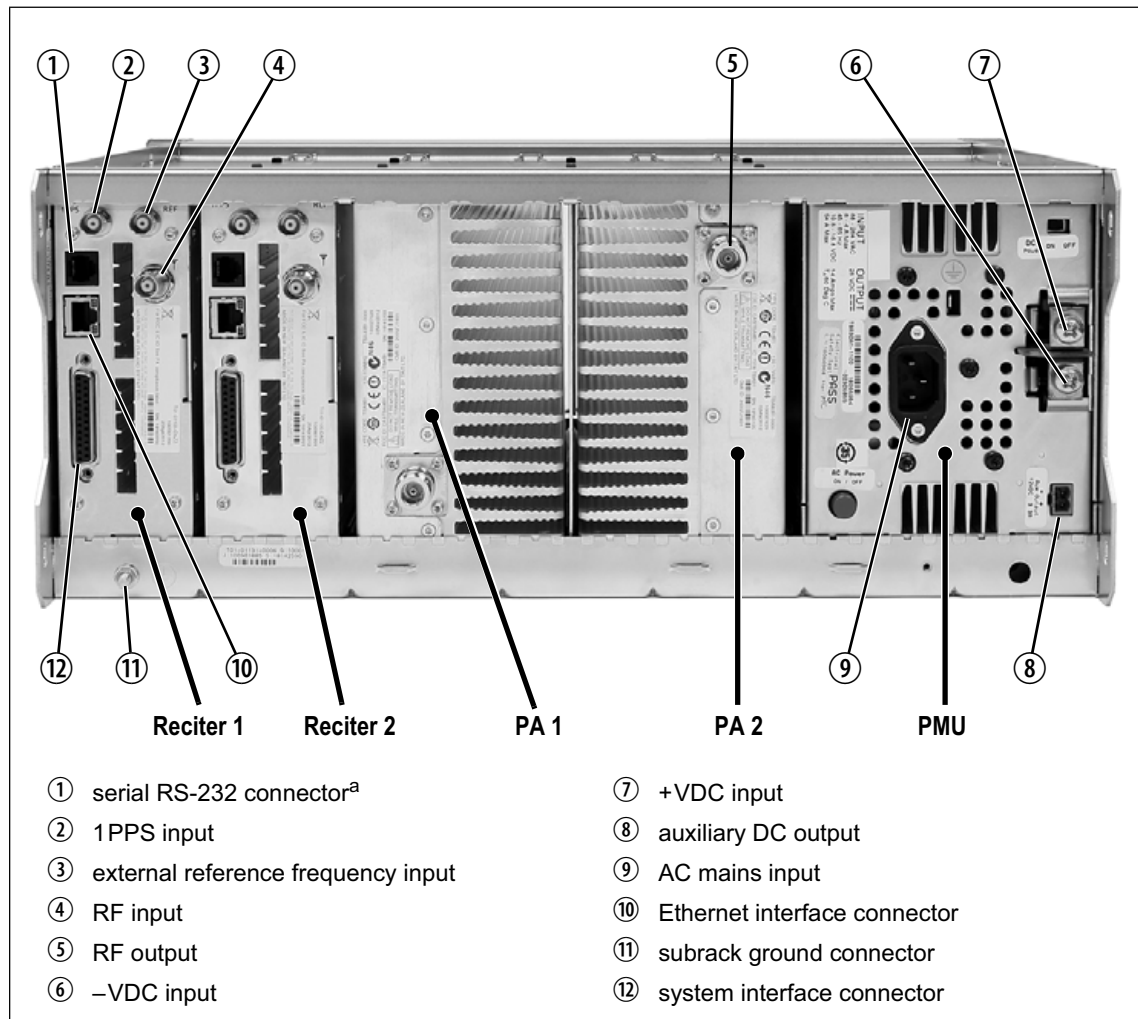

a. Factory use only.

5.6.2 Connecting AC Power

The PMU is designed to accept a mains input of 88 to 264 VAC at 45 to 65 Hz. A standard 3-wire grounded socket outlet must be used to supply the AC power. The socket outlet must be installed near the equipment and must be easily accessible. This outlet should be connected to an AC power supply capable of providing at least 600 W. The requirements of two typical AC supplies are given in the following table.

Nominal Supply	Current Requirement ^a	Circuit Breaker/Fuse Rating ^a
115VAC	8A	10A
230VAC	4A	6A

a. The actual current consumption of the base station will be lower than these requirements (refer to the Specifications Manual for more information).

Your base station should come supplied with a power supply cord to connect the male IEC connector on the PMU to the local AC supply. The pins of the IEC connector on the PMU are identified at right.

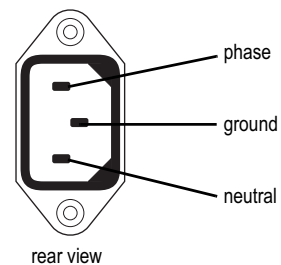

5.6.3 Connecting DC Power

The PMU is designed to accept a nominal 12VDC, 24VDC or 48VDC input (depending on the model) with negative or positive ground. There is a minimum DC startup threshold to prevent damaging a battery which has little capacity left.

You must connect the DC supply from the battery to the PMU via a fuse or DC-rated circuit breaker with a contact separation of 3 mm, and with the appropriate rating, as shown in the table below. The DC input leads should be of a suitable gauge to ensure less than 0.2 V drop at maximum load over the required length of lead.

Nominal Supply Voltage	Input Voltage Range	Circuit Breaker/ Fuse Rating ^a	Recommended Wire Gauge ^b
12VDC	10VDC to 16.8VDC	60A	2AWG / 35mm ²
24VDC	20VDC to 33.6VDC	30A	5AWG / 16mm ²
48VDC	40VDC to 60VDC	15A	8AWG / 8mm ²

a. The actual current consumption of the base station will be lower than these requirements (refer to the Specifications Manual for more information).

b. For a length of 5ft to 6.5ft (1.5m to 2m) (typical).

Terminate and insulate the DC input leads to protect them from accidentally shorting to the subrack if the PMU is removed before the leads are disconnected. Protective covers for the DC terminals are supplied with each PMU.

Figure 5.8 Recommended DC power connection

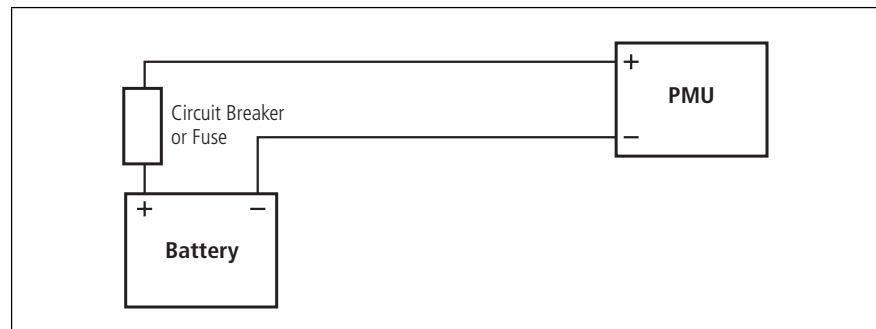

We recommend a screw torque of 18–20 lbf·in (2–2.25 N·m).

5.6.4 Connecting the Auxiliary DC Power Output

The PMU can provide an auxiliary DC output when it is fitted with the auxiliary power supply board. This board is available with an output of 13.65VDC, 27.3VDC, or 54.6VDC (depending on the model), and is current limited to 3 A, 1.5 A or 750mA respectively. This power supply is permanently on as soon as the base station has finished powering up, and is available on the auxiliary output connector on the rear panel.

You can connect multiple auxiliary power supply boards in parallel for redundancy purposes, or to provide an output greater than 40W. Although no active current sharing is used, auxiliary boards connected in parallel will current-share before reaching their power limit. The failure (or switching off) of one auxiliary board will not load any other paralleled auxiliary boards in the circuit.

Auxiliary DC Power Output Cabling

Network elements are supplied with a connector, as shown in [Figure 5.9](#). You can use this to connect the PMU's auxiliary DC power output to another device (refer to “[PMU Auxiliary DC Output](#)” on page 105 for the pin allocations).

Contact your regional Tait office for details on the full range of wiring kits available.

Figure 5.9 Auxiliary DC power connector

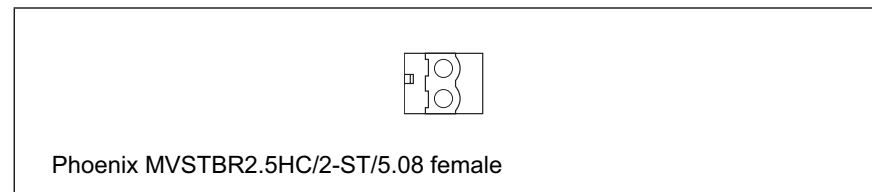

5.6.5 Connecting RF

Notice Do not remove the load from the PA while it is transmitting as this may damage the PA output stage.

The RF input to the base station is via the marked BNC connector on the rear panel of the reciter. The RF output is via the N-type connector on the rear panel of the PA (refer to [Figure 5.7 on page 79](#)).

Cables and antennas should be of high quality construction. Solid shield heliax type cables are best, but if braided shield cables must be used for short distances, their braids must be silver-plated.

Recommendations for Installing the PA

We recommend the following installation procedures, which should protect the PA from damage under all but the most extreme operating conditions.

1. Do not connect the PA directly to the antenna. Fit an isolator or duplexer between the PA and the load. Fit the isolator as close as possible to the RF output connector on the PA. Do not connect any switching equipment between the isolator and the PA, unless the switch **cannot** operate while there is RF present (i.e. the base station is transmitting).
2. Fit a surge suppressor to the antenna cabling where it enters the building.
3. Inspect all cables and equipment connected to the base station for defects.

Ice on the antenna, or a broken antenna, is unlikely to cause damage to the PA.

Explanation

The circuit design of the PA protects the circuitry from high VSWR. This makes it difficult to damage the RF power device by keying the PA into a mismatched load, or if the load deteriorates over even a short period of time (milliseconds).

However, it is possible to damage the device if **all** the following conditions happen **at the same time**:

- there is a step change in the PA load (for example, the load is removed)
- the PA is transmitting
- the feed line loss between the PA and the mismatch is <1 dB.

The effect of such conditions is variable: some devices will not be destroyed, and some may fail after repeated load interruptions.

5.6.6 Connecting an External Frequency Reference

An external reference frequency is not normally required for B3 band. However, an external reference can be used with a TB9300 when you need to maximize the range of the base station. The external reference frequency can be 10MHz or 12.8MHz, with an input level of 300mV_{pp} to 5V_{pp}. The stability of this reference should be better than 50 parts per billion. The reciter automatically detects the frequency of the external reference and configures itself accordingly.

If an external reference is required, enable the external reference “Absent” alarm (Configure > Alarms > Control).

Use a 50Ω coaxial cable (RG58 or RG223) to connect the external reference to the base station’s external reference frequency input. You can daisy-chain up to eight base stations using F-junctions. The maximum overall cable length is 30m. Terminate the last connection with a 50Ω load.

Figure 5.10 Daisy-chaining an external frequency reference input

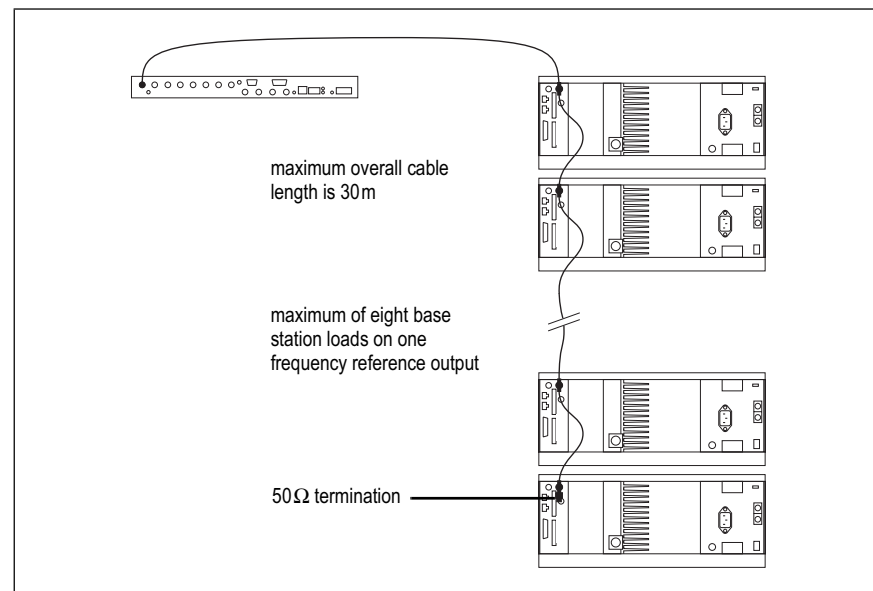

5.6.7 Ethernet Connection

The RJ-45 socket on the reciter's rear panel provides the 10BASE-T or 100BASE-T Ethernet connection to the other devices in the network. Use Cat-5 cable to connect this socket to the TaitNet DMR Network via a router or switch.

If necessary, refer to [“Ethernet Connector” on page 105](#) for a list of Ethernet connection pin allocations.

5.6.8 Connecting General Purpose Inputs and Outputs

The base station has a number of general purpose inputs and outputs. These are connected via the 25-way D-range on the rear panel.

The pin allocations for the D-range connector are given in the following table. Not all pins are used in this release of the base station.

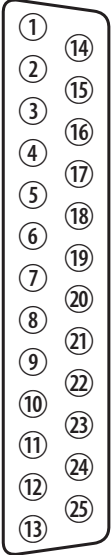
	Pin	Signal Name	Signal Type	Notes	
 <p>external view</p>	1	not used		reserved for future use	
	2				
	3				
	4				
	5				
	6				
	7				
	8				
	9				
	10				
		11	digital in 1	input	5V TTL logic active low
		12	digital in 2		
		13	+5.2VDC output	power output	maximum current 200mA
		14	digital in 3	input	5V TTL logic active low
		15	digital in 4		
		16	digital in 5		
		17	digital in 6		
		18	digital in 7		
		19	digital in 8		
		20	digital in 9		
		21	digital in 10		
		22	digital in 11		
		23	digital in 11		
		24	not used		
		25	ground	ground	