

**T830 Series II**  
**Base Station Equipment**  
**Service Manual**

**Preliminary Issue**

**August 1997**

**(Not For Resale)**



### Head Office New Zealand

Tait Electronics Ltd  
558 Wairakei Road  
P.O. Box 1645  
Christchurch  
New Zealand  
Phone: 64 3 358-3399  
Fax: 64 3 358-3636

### Radio Infrastructure Division

535 Wairakei Road  
P.O. Box 1645  
Christchurch  
New Zealand  
Phone: 64 3 358-3399  
Fax: 64 3 358-2825

### Australia

Tait Electronics (Aust) Pty Ltd  
275 Toombul Road  
Northgate 4013  
P.O. Box 679  
Virginia  
Queensland 4014  
Australia  
Phone: 61 7 3260-7799  
Toll Free: 1800 077-112  
Fax: 61 7 3260-7990

### Canada

Tait Mobile Radio Inc.  
Unit 5, 158 Anderson Avenue  
Markham  
Ontario L6E1A9  
Canada  
Phone: 1 905 472-1100  
Toll Free: 1 800 890-8248  
Fax: 1 905 472-5300

### France

Tait France Sarl  
2 Avenue de la Cristallerie  
92 316 Sèvres, Cedex  
France  
Phone: 33 1 41 14-05-50  
Fax: 33 1 41 14-05-55

### Germany

Tait Mobilfunk GmbH  
Willstätterstraße 50  
D-90449 Nürnberg 60  
Germany  
Phone: 49 911 96 746-0  
Fax: 49 911 96 746-79

### Hong Kong

Tait Mobile Radio (HK) Ltd  
Room 703A  
New East Ocean Centre  
9, Science Museum Road  
Tsim Sha Tsui East  
Hong Kong  
Phone: 852 2369-3040  
Fax: 852 2369-3009

### New Zealand

Tait Communications Ltd  
Unit 4, 75 Blenheim Road  
P.O. Box 1185  
Christchurch  
Phone: 64 3 348-3301  
Fax: 64 3 343-0558

### Singapore

Tait Electronics (Far East) Pte Ltd  
4 Leng Kee Road  
SIS Building #05-11A  
Singapore 159088  
Phone: 65 471-2688  
Fax: 65 479-7778

### Taiwan

Tait Electronics (Taiwan) Ltd  
1104, No. 142 Chung Hsiao E. Rd  
Sec. 4  
Taipei  
Taiwan  
Phone: 886 2 731-1290  
Fax: 886 2 711-6351

### Thailand

Tait Mobile Radio Ltd  
14/1 Suwan Tower  
Ground Floor  
Soi Saladaeng 1  
North Sathorn Road  
Bangrak  
Bangkok 10500  
Thailand  
Phone: 662 267-6290-2  
Fax: 662 267-6293

### United Kingdom

Tait Mobile Radio Ltd  
Ermine Business Park  
Ermine Road  
Huntingdon  
Cambridgeshire PE18 6YA  
United Kingdom  
Phone: 44 1480-52255  
Fax: 44 1480-411996

### USA

Tait Electronics (USA) Inc.  
9434 Old Katy Road  
Suite 110  
Houston  
Texas 77055  
USA  
Phone: 1 713 984-8684  
Toll Free: 1 800 222-1255  
Fax: 1 713 468-6944

## About This Manual

### Scope

This manual contains preliminary servicing information on T830 Series II 25W, 50W and 100W base stations which comprise the following equipment:

25W base station	T835 receiver T836 25W transmitter
50W base station	T835 receiver T837 exciter T838 50W power amplifier
100W base station	T835 receiver T837 exciter T839 100W power amplifier

### Contents

Part A contains information on the following procedures:

- changing the operating frequency
- retuning the module after changing frequency
- configuring the audio processor
- T838/839 user information

Parts B to G contain the following PCB information:

- parts lists
- grid reference indexes
- PCB layout diagrams
- test points & options diagrams
- circuit diagrams

Part H contains the following information on the T800-22-0000 rack frame:

- general information
- circuit operation
- parts lists
- PCB layout diagrams

## Technical Information

Any enquiries regarding this manual or the equipment it describes should be addressed in the first instance to your nearest approved Tait Dealer or Service Centre. Further technical assistance and copies of this manual may be obtained from the Customer Support Group, Radio Infrastructure Division, Tait Electronics Ltd, Christchurch, New Zealand.

## Date Of Issue

T830 Series II Preliminary Service Manual published August 1997

## Table Of Contents

Part	Title
A	Changing The Operating Frequency Of The T800 Series II
B	T835 Receiver Preliminary PCB Information
C	T836 Transmitter Preliminary PCB Information
D	T837 Exciter Preliminary PCB Information
E	T838 Power Amplifier Preliminary PCB Information
F	T839 Power Amplifier Preliminary PCB Information
G	T830 VCO Preliminary PCB Information
H	T800-22-0000 Rack Frame

## Using The Parts Lists

In this manual there are separate parts lists for each product type. The table below shows which lists to use for each product type.

To refer to the parts list for a . . .	use the following sections . . .	
	T835/T836/T837	T838/T839
T83X-10	D83X-10-001 XE83X-10-001	D83X-10-0300 XE83X-10-0300
T83X-13	D83X-13-001 XE83X-13-001	
T83X-15	D83X-15-001 XE83X-15-001	
T83X-20	D83X-20-001 XE83X-20-001	D83X-20-0300 XE83X-20-0300
T83X-23	D83X-23-001 XE83X-23-001	
T83X-25	D83X-25-001 XE83X-25-001	
T83X-1X VCO	XE83XV10	
T83X-2X VCO	XE83XV20	



## Overview

---

### Introduction

When you receive the T800 module it will be run up and working on a particular frequency. Sometimes you may want to change the operating frequency. In some cases, when you change the operating frequency, it will also be necessary to re-tune the radio to ensure correct operation.

---

### Purpose of this document

It is the purpose of this document to familiarise you with the procedures that must be carried out to check that the radio is still operating correctly, and how to re-tune the radio when this is not the case.

---

### In this section

This section covers the following topics:

Topic	See page
How to change the operating frequency	2
How to re-tune the T835	4
How to re-tune the T836/837	7
Configuring the Audio Processor	11
How to determine if the T835/836/837 is still operating	16



## How to change the operating frequency

### Description

There are two possible ways of changing the operating frequency:

<b>Method 1</b>	<b>By using a computer running PGM800Win and</b> <ul style="list-style-type: none"><li>• Changing the default channel in the existing setup</li></ul> or <ul style="list-style-type: none"><li>• Reprogramming the radio channel frequencies and then selecting a default channel</li></ul> <p>NOTE: Please refer to the T830 service manual and the PGM800WIN programming manual for further instruction.</p>
<b>Method 2</b>	<b>By selecting a new channel using the DIP switch on the rear of the PCB Backplane or some other form of installed channel change switch i.e. BCD, Internal DIP switch.</b>

### After changing the operating frequency

Having changed the operating frequency of the T830 there are two different scenarios you will be faced with:

- You will change the frequency and the T830 will continue to operate correctly. In this case you have changed to a frequency within the switching band of the radio.
- You will change the frequency and the T830 will not operate or will not operate correctly. In this case you have changed to a frequency outside of the switching band.

**Note:** The radio must now be re-tuned (see next section “How to re-tune the T835” & “How to re-tune the T836/837”).

### What is the switching band

Because of the high RF performance of the T800 series there is a limit to the amount of frequencies that the radio can switch to before re-tuning must occur. The limit is referred to as the switching bandwidth.

- The T830 Rx can switch up to 3MHz.
- The T830 Tx can switch up to 8MHz.

So if the T830 is optimally tuned to a centre frequency (which is often the case when sent from the factory) then the Rx or Tx will be able to switch half the switching band either side of that frequency.



## Changing the Operating Frequency of the T800 SeriesII

---

### Example

A T830 receiver has been tuned optimally for 460MHz. Therefore, it's switching range is  $460-1.5\text{MHz}$  to  $460+1.5\text{MHz}$ . i.e. 458.5MHz to 461.5MHz.



## Changing the Operating Frequency of the T800 Series II

# How to re-tune the T835

**Equipment required** You will need:

Computer with PGM800Win installed  
T800 programming kit  
T800 test & calibration unit  
Digital multimeter  
Audio signal generator  
RF signal generator  
Audio voltmeter  
Sinad meter

or

Computer with PGM800Win installed  
T800 programming kit  
T800 test & calibration unit  
RF test set

### Before you start

- Remove the top cover of the module (the side closest to the handle).
- Set up the test equipment as shown below.

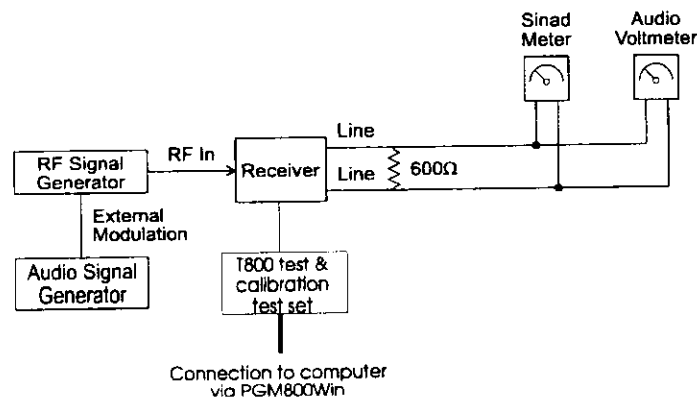

- Set the jumpers in the audio section of the module as required (see section "Configuring the Audio Processor").
- Connect the computer to the module using the PGM800Win programming kit.





## Changing the Operating Frequency of the T800 SeriesII

### How to re-tune the T835 cont..

#### Steps involved

The service manual has a section which describes a full Initial Tuning and Adjustment procedure. This must be used if a repair has been made or some other major characteristic has been changed. If the only adjustment made has been to switch to a channel outside the switching band, then the following steps should be followed.

- Change the operating frequency
- Lock the VCO
- Align the front end
- Set the noise mute
- Set the line output level

The procedure is described below.

#### Procedure

Follow the steps below to retune the T835 if the frequency has been changed and the radio stops operating.

Step	Action
<b>Lock the VCO</b>	
1	Connect a high impedance voltmeter to the long lead of L1 in the VCO (this measures the synthesiser loop voltage).
2	<b>Single channel</b> Tune VCO trimmer C6 for a synthesiser loop voltage of 10V.  <b>Multichannel</b> Tune VCO trimmer C6 for a synthesiser loop voltage of 10V on the middle channel.  If there is no middle channel, tune C6 so that the channels are symmetrically placed around a loop voltage of 10V.  All channels should lie within the upper and lower limits of 16V and 3V respectively.  Do not attempt to programme channels with a greater frequency separation than the specified switching range.



## Changing the Operating Frequency of the T800 Series II

<b>Align the front end</b>	
Settings are first given for wide band sets, followed in brackets by settings for narrow band [ ]. For multichannel operation the receiver should be aligned on a middle frequency.	
<b>Fre- quency range</b>	136-156MHz: With the power supply switched off, solder bridge links SL405, 410, 415, 430, 435, 440 and link B in the front end 148-174MHz: Solder bridge link A and ensure links SL405, 410, 415, 430, 435, 440 linkB are not connected.
<b>1</b>	Inject a strong on-channel RF signal with 3kHz deviation [1.5kHz] at 1kHz into the antenna socket and adjust L410, L420, L460 & L470 to give best sinad.
<b>2</b>	Continually decrease the RF level to maintain 12dB SINAD.
<b>3</b>	Readjust the front end doublets (L410, L420, L460 & L470 to give best sinad.
<b>4</b>	The receiver sensitivity should be better than -117dBm, assuming that the audio levels are not being overdriven (refer to Line Amplifier Output below).
<b>Set the noise mute</b>	
<b>1</b>	Connect pins 1&2 of PL250 to enable the noise mute.
<b>2</b>	Set the RF level to -105dBm with 3kHz deviation [1.5kHz] at 1kHz.
<b>3</b>	Set RV230 (gate sensitivity) fully anticlockwise.
<b>4</b>	Adjust RV330 to close the mute (if necessary turn off the RF signal and then turn it on again).
<b>5</b>	Rotate RV330 anticlockwise until the mute just opens.
<b>6</b>	Adjust RV230 (gate sensitivity) on the front panel for the required opening sinad.
<b>Set the line output level</b>	
<b>1</b>	Apply an on-channel signal from the RF generator at a level of -70dBm with 3kHz deviation [1.5kHz] at 1kHz.
<b>2</b>	Adjust the front panel line level pot. (RV210) to give an output of +10dBm on the 600 ohm line.
<b>3</b>	Set the line level to the required output level.



## How to re-tune the T836/837

### Equipment required

You will need:

Computer with PGM800Win installed  
T800 programming kit  
T800 test & calibration unit  
Digital multimeter  
Oscilloscope (digital preferred)  
Audio signal generator  
Audio voltmeter x 2  
RF power meter  
Modulation meter  
20dB pad

or

Computer with PGM800Win installed  
T800 programming kit  
T800 test & calibration unit  
RF test set

### Before you start

- Remove the top cover of the module (the side closest to the handle).
- Set up the test equipment as shown below.

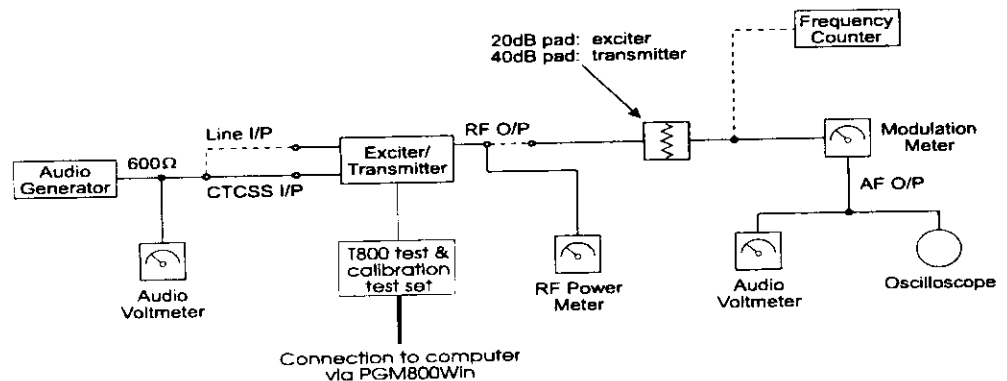

- Set the jumpers in the audio section of the module as required (see section “Configuring the Audio Processor”).
- Connect the computer to the module using the PGM800Win programming kit.



## How to re-tune the T836/837 cont..

### Steps involved

The service manual has a section which describes a full Initial Tuning and Adjustment procedure. This must be used if a repair has been made or some other major characteristic has been changed. If the only adjustment made has been to switch to a channel outside the switching band, then the following steps should be followed.

- Change the operating frequency
- Lock the VCO to produce the output frequency
- Adjust the output power
- Set the dual point modulation
- Set the FM deviation
- Reset the line-in level

The procedure is described below.

### Procedure

Follow the steps below to retune the T836 or T837 if the frequency has been changed and the radio stops operating.

Step	Action
<b>Lock the VCO to produce the output frequency</b>	
1	Connect a high impedance voltmeter to the long lead of L1 in the VCO (this measures the synthesiser loop voltage).
2	<b>Single channel</b> Tune VCO trimmer C6 for a synthesiser loop voltage of 10V.  <b>Multichannel</b> Tune VCO trimmer C6 for a synthesiser loop voltage of 10V on the middle channel.  If there is no middle channel, tune C6 so that the channels are symmetrically placed around a loop voltage of 10V.  All channels should lie within the upper and lower limits of 16V and 3V respectively.  Do not attempt to programme channels with a greater frequency separation than the specified switching range.



## Changing the Operating Frequency of the T800 SeriesII

<b>Adjust the Output power (T856 only)</b>	
<b>1</b>	Connect an RF power meter to the output socket and key the transmitter
<b>2</b>	Set power control RV320 fully clockwise
<b>3</b>	Adjust CV451 for maximum output power and check that this exceeds 30W
<b>4</b>	Adjust power control RV320 for required power output
<b>5</b>	Readjust CV451 to reduce the supply current by up to 0.5A.
<p><b>Set the dual point modulation (to maximise the modulation response).</b>            Settings are first given for wide band sets, followed in brackets by settings for narrow band [ ]</p>	
<b>Multiple channels</b>	<ul style="list-style-type: none"> <li>• To optimise the modulation response across the switching band repeat steps 1-4 for each channel that will be used (usually only needed for data applications).</li> <li>• For usage where the modulation response is less critical (e.g. voice use only) follow steps 1-4 on the middle channel and then cut and paste the value for all other channels.</li> </ul>
<b>1</b>	Inject an audio signal of 600Hz 1.5Vrms (+5dBm) into the CTCSS input (D-range pin 8). Key the transmitter.
<b>2</b>	Adjust the output from the audio generator to obtain +/-3kHz [ +/-1.5kHz] deviation at 600Hz.
<b>3</b>	Change the input frequency to 120Hz and using PGM800Win, adjust the "Reference modulation" (by using the mouse or up and down arrow keys) to obtain +/-3kHz [ +/-1.5kHz] deviation.
<b>4</b>	Change the input frequency back to 600Hz.  Repeat steps 2 and 3 above until the deviations achieved at the two input frequencies are within 0.2dB of each other. This will need to be done at least four time.
<b>5</b>	Sweep the audio between 50 and 300Hz for peaks. A peak indicates a fault condition (incorrect setup or modulation circuitry fault).  The specification window is +/-1dB relative to 150Hz from 65 to 260Hz.



## Changing the Operating Frequency of the T800 Series II

<b>Set the FM deviation (limiter adjustment)</b>	
<b>1</b>	Inject 1kHz at -10dBm into the line input (D-range pins 1 & 4; pins 2 & 3 shorted).
<b>2</b>	Adjust RV210 (line sensitivity) fully clockwise and earth the key line. Using PGM800Win, adjust the "Deviation" (by using the mouse or up and down arrow keys) to set the peak deviation to +/-4.7kHz [ +/-2.3kHz].
<b>3</b>	<p>Sweep the audio frequency from 100Hz to 4kHz and ensure that the maximum deviation does not exceed 4.7kHz [2.3kHz]. Re-adjust "Deviation" if necessary.</p> <p>Note:</p> <ul style="list-style-type: none"><li>• If the radio is to be used over the whole switching bandwidth (8MHz) the deviation should be set for each channel.</li><li>• If the frequencies to be switched over is less than 1MHz then the deviation can be set on the middle channel and this value used for all other channels using the "fill" option in PGM800Win.</li></ul>
<b>Reset the line-in level</b>	
<b>1</b>	Set the injected signal at the line input to the required line level (typically -10 to -20dBm).
<b>2</b>	Adjust RV210 (line sensitivity) to provide +/-3kHz [ +/-1.5kHz] deviation.



## Configuring the Audio Processor

### Introduction

There are a number of links in the T835, 836 & T837 that can be changed to configure the audio processor in various ways. The linking options are given below for each of the T830 modules followed by a block diagram of the audio processor and link configurations.

### T835 audio processor links

Use the table below to set up the audio processor as you require it.

#### General

Plug	Link	Function
PL210	1 - 2 2 - 3	de-emphasised response flat response
PL220	1 - 2 2 - 3	flat response de-emphasised response
PL230	1 - 2 2 - 3 3 - 4	audio input via audio 2 pad audio from internal CTCSS speech filter audio input via I/O pad P250
PL240	1 - 2  2 - 3 or 3 - 4  4 - 5	bypass high pass filter  300Hz high pass filter in circuit  audio input via PL230 or I/O pad P250
PL250	1 - 2 2 - 3	noise mute carrier mute
PL260	1 - 2 2 - 3	Rx disable link not connected
PL270	1 - 2 2 - 3	relay link not connected
Options should be selected before alignment of the receiver is attempted.		



## Configuring the Audio Processor cont..

### T835 audio processor links cont..

#### For CTCSS

The audio processor links must be appropriately connected for the CTCSS option used as shown in the table below.

CTCSS Option	PL230	PL240
standard, no CTCSS	2 - 3	2 - 3
received CTCSS tone + speech to line output	3 - 4	1 - 2
high pass filtered speech + internal CTCSS detection	2 - 3	4 - 5
external CTCSS detection	1 - 2	4 - 5

The conditions stated in the above table are defined as follows:

#### standard, no CTCSS

- no CTCSS or other sub-audio signalling used
- audio bandwidth 300Hz to 3kHz
- hum & noise -55dB

#### received CTCSS + speech to line output

- tone and speech transmitted down 600 ohm line
- audio bandwidth 10Hz to 3kHz
- hum & noise -45dB

#### high pass filtered speech + internal CTCSS detection

- decoding performed in receiver
- audio bandwidth 400Hz to 3kHz
- hum & noise -30dB with 250.3Hz tone present

#### external CTCSS

- decoding performed through the receiver (but externally) by T310-05 or similar
- speech injected back into receiver via "audio 2" and sent down 600 ohm line





## Changing the Operating Frequency of the T800 SeriesII

### Note:

- 1) Audio 2 is available via D range connector PL100 Pin7 via the link resistor R160. PL100 Pin7 is already assigned to serial com. but this can be disabled by removing R808.
- 2) External CTCSS units can be connected in series with audio via Audio 1 and Audio 2.

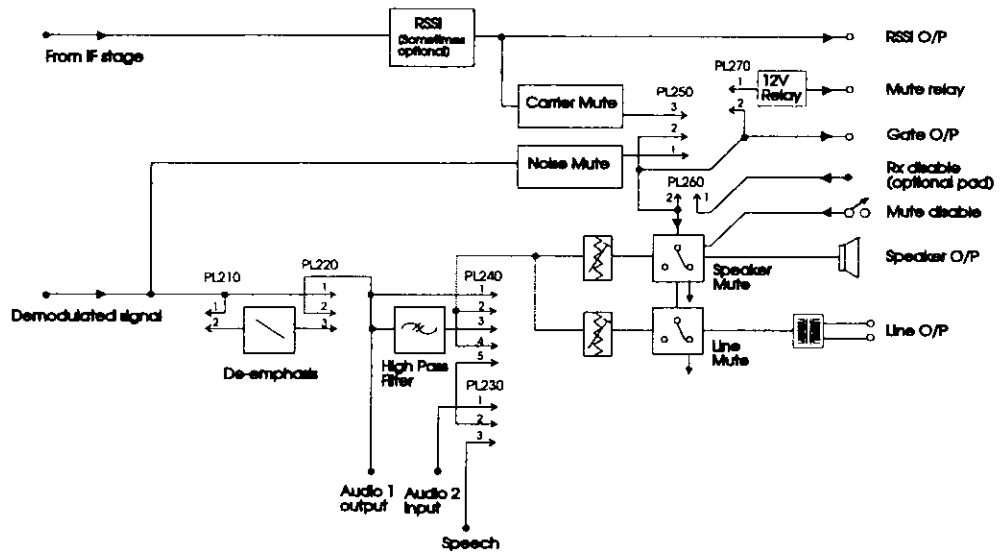

T835 Audio processor block diagram showing link options



## Configuring the Audio Processor cont..

### T836/T837 audio processor links

Use the table below to set up the audio processor as you require it.

#### General

Plug	Link	Function
PL205	(A) 1 - 2 (B) 3 - 4 (C) 5 - 6	not connected microphone pre-amp. output to compressor input microphone pre-amp. output to multiplexer input
PL210	(L) 1 - 2 (M) 3 - 4 (N) 5 - 6	multiplexer output to pre-emphasis input multiplexer output to limiter input multiplexer output to compressor input
PL215	(G) 1 - 2 (H) 3 - 4 (I) 5 - 6 (J) 7 - 8 (K) 9 - 10	not connected compressor output to multiplexer input compressor output to limiter input compressor output to pre-emphasis input not connected
PL220	(D) 1 - 2 (E) 3 - 4 (F) 5 - 6	pre-emphasis output to multiplexer input pre-emphasis output to limiter input not connected

#### Typical options

	PL205	PL210	PL215	PL220
microphone pre-amp. compressed and pre-emphasised; line input pre-emphasised (standard set-up)	(B) 3 - 4	(L) 1 - 2	(H) 3 - 4	(E) 3 - 4
microphone pre-amp. compressed and pre-emphasised; line input unprocessed	(B) 3 - 4	(M) 3 - 4	(J) 7 - 8	(D) 1 - 2
line and microphone compressed and pre-emphasised	(C) 5 - 6	(N) 5 - 6	(J) 7 - 8	(E) 3 - 4
microphone pre-amp compressed; line and microphone flat response:	(B) 3 - 4	(M) 3 - 4	(H) 3 - 4	(F) 5 - 6



## Changing the Operating Frequency of the T800 SeriesII

### Configuring the Audio Processor cont..

T836/T837 audio processor links cont..

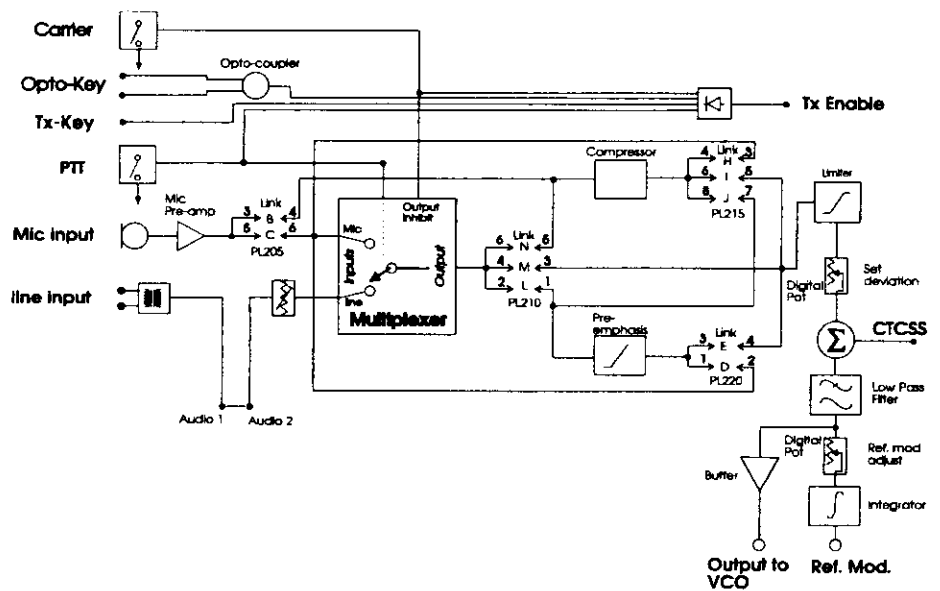

T836/837 Audio processor block diagram showing link options



## How to determine if the T835/836/837 is still operating

### Introduction

If the radio was working fine and you want to check that it is still operating correctly, after changing the operating frequency, follow the steps listed below.

---

### Procedure

Follow the steps below to perform a quick check of correct operation.

Step	Action
1	Remove the top cover of the module (the side closest to the handle).
2	Connect a high impedance voltmeter to the long lead of L1 in the VCO (this measures the synthesiser loop voltage).
3	Ensure the measured DC voltage is between 5 & 15V

**Note:** If the T835 Receiver is not operating this will be indicated by a slow flashing of the Green Supply light. This should be used as a visual check followed by the more definitive check given above.



---

## Operating the power amplifiers

---

### Introduction

The T838/839 power amplifiers are designed to operate at 50 Watts and 100 Watts respectively at ambient temperatures up to 60 degC. Operation at higher power or higher temperature will result in decreased service life.

We have designed two safeguards into the equipment. Please read about them below and note the warning when you install the equipment.

---

### Equipment safeguards.

#### Maximum power clamp

This is to prevent over-dissipation in the power modules resulting in excess temperature rise. The level is factory preset and should not need field adjustment.

**Warning:** Should adjustment be necessary you must follow the procedure outlined next to prevent damage to the module. Turn front panel power control up full, adjust clamp potentiometer for 120W (T839) 60W (T838) and readjust front panel power control for 100W (T839) 50W (T838).

#### Multi point temperature sensed power turn down

In addition to the usual temperature sensor that controls the fan (T839), the heat-sink temperature of each power module is also sensed. Should the temperature rise excessively, by mis-adjustment or poor airflow, the output power will automatically reduce until the temperature is reduced.

---

### Important

In all installations it is important to ensure good airflow to ensure ambient temperature does not exceed 60 degC on any units in the rack. Rack mounted fans are recommended, particularly where several channels are installed in one cabinet.

## 2.9 T837 Exciter Drive Amplifier

(Refer to Figure 2.2 and the exciter circuit diagram (sheet 3) in Section 6.3.)

A two-stage, wide band amplifier (Q365, Q370) provides an output level of approximately 800mW (+29dBm) for an input of 170mW (+22dBm) from the VCO. IC330 pins 5, 6 & 7, Q310, and Q315 provide a 10.5V regulated supply for the exciter.

To reduce the spurious output level when the synthesiser is out-of-lock, the Tx-Reg. and Lock-Detect signals are gated to inhibit the exciter control circuit and to switch off the RF signal at the input to the drive amplifier. This is achieved by a PIN switch attenuator (D340, D350, D360).

Cyclic keying control is provided by additional circuitry consisting of several time delay, ramp and gate stages:

- Q305, IC330 pins 5, 6 & 7      power ramping
- Q340, Q345                      Tx-Reg. and Lock-Detect gate
- Q320, Q325, Q330, Q335      delay and PIN switch drive.

This is to allow the RF power circuits (both exciter and PA) to ramp up and down in a controlled manner so that minimal adjacent channel interference is generated during the transition.

R359, R360 and R362 form a 6dB attenuator to provide good VCO/drive amplifier isolation.

The output attenuator (R392, R390, R394, R396) assists in reducing exciter/PA interaction while also ensuring a good match for Q370.

**Note:** The exciter provides a DC control signal to the PA via the RF coax. This is injected via L390.

  
 FCC ID: CASTEL0007  
 EXCITER: 2.983 (d) (1c)

**T830 Series II**  
**Base Station Equipment**  
**136-174MHz**

**Service Manual**

**Issue 200**

**April 1998**

**M830-00-200**

Receiver/Transmitter/Exciter

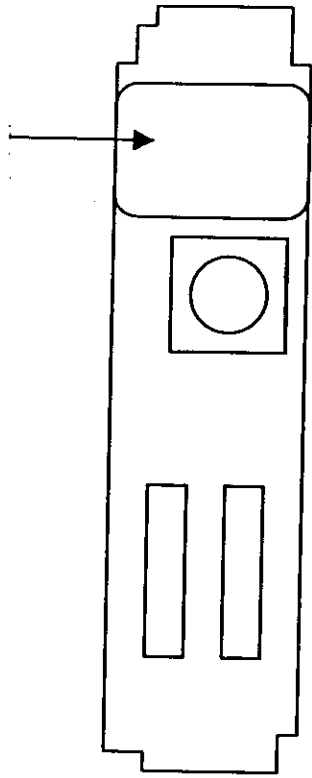

PA

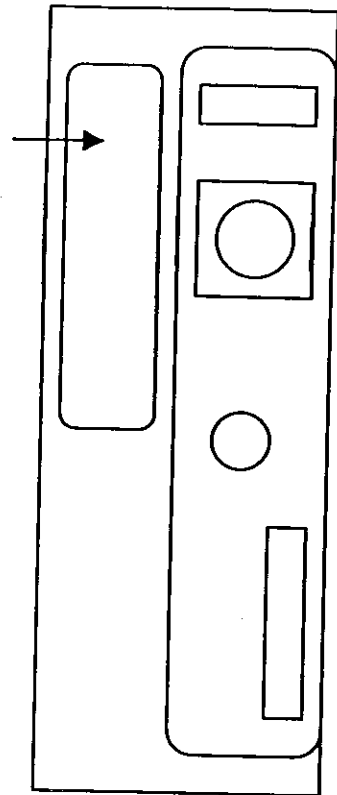



## Part C T836 Transmitter & T837 Exciter

This part of the manual is divided into six sections, as listed below. There is a detailed table of contents at the start of each section.

<b>Section</b>	<b>Title</b>
<b>1</b>	<b>General Information</b>
<b>2</b>	<b>Circuit Operation</b>
<b>3</b>	<b>Initial Tuning &amp; Adjustment</b>
<b>4</b>	<b>Functional Testing</b>
<b>5</b>	<b>Fault Finding</b>
<b>6</b>	<b>PCB Information</b>

## 1.1 Introduction

The T836 is a synthesised, microprocessor controlled FM base station transmitter designed for single or multichannel operation in the 136 to 174MHz frequency range with a standard power output of 25W. The RF section of the transmitter comprises a frequency synthesiser which provides 170mW of frequency modulated RF drive to a two stage, wide band output driver followed by a 25W power amplifier. A thermal shut-down feature is provided in the T836 in case operating temperatures exceed acceptable levels.

The T837 is a synthesised, microprocessor controlled FM base station exciter designed for single or multichannel operation in the 136 to 174MHz frequency range. With a standard power output of only 800mW, the exciter is designed for use with the T838 50W or T839 100W power amplifiers. The RF section of the exciter comprises a frequency synthesiser which provides 170mW of frequency modulated RF drive to a two stage, wide band output amplifier.

A wide selection of audio characteristics may be obtained from the audio processor. Optional circuit blocks are an audio compressor and a pre-emphasis stage. They can be bypassed or linked to one or both audio inputs, and then back into the remaining audio circuitry in almost any combination. All audio processor options are link selectable.

The synthesiser frequency is programmed via the serial communications port. Eight channel select lines are accessible via an optional D-range connector (D-range 2 - T800-03-0000) at the rear of the set.

All components except those of the VCO are mounted on a single PCB. This is secured to a die-cast chassis which is divided into compartments to individually shield each section of circuitry. Access to both sides of the main circuit board is obtained by removing each of the chassis lids. There is provision within the chassis to mount small option PCBs.

The front panel controls include line sensitivity, microphone socket and carrier switch. This switch turns on the carrier (unmodulated) as an aid to servicing.

The T836 and T837 are both 60mm wide and each occupies a single space in a Tait rack frame, which has the ability to accommodate up to seven standard modules.

## Dimensions:

Height	.. 183mm
Width	.. 60mm
Length	.. 320mm

## Weight

.. 2.1kg

## Time-Out Timer (optional)

.. 0 to 5 minutes adjustable in 10 second steps

## Tail Timer

.. 0 to 5 seconds adjustable in 100ms steps

## Transmit Key Time

.. &lt;30ms

## Transmit Lockout Timer

.. 0 to 1 minute adjustable in 10 second steps

**1.2.3 RF Section**

## Frequency Range

.. 136-174MHz (refer to Section 1.4 and Section 1.5)

## Modulation Type

.. FM

## Frequency Increment

.. 5 or 6.25kHz

## Switching Range

.. 8MHz

## Load Impedance

.. 50 ohms

## Frequency Stability

..  $\pm 2.5$ ppm, -30°C to +60°C

(see also Section 1.4 and Section 1.5)

## Adjacent Channel Power (full deviation):

Wide Bandwidth (WB) ( $\pm 25$ kHz/15kHz B/W)	.. -75dBc
Mid Bandwidth (MB) ( $\pm 20$ kHz/12kHz B/W)	.. -70dBc
Narrow Bandwidth (NB) ( $\pm 12.5$ kHz/7.5kHz B/W)	.. -65dBc

## Transmitter Side Band Noise:

(no modulation, 15kHz bandwidth)

At $\pm 25$ kHz	.. -95dBc
At $\pm 1$ MHz	.. -105dBc

### 1.2.4.2 Modulation Characteristics

Frequency Response (below limiting)	.. flat or pre-emphasised (optional)
Line And Microphone Inputs:	
Pre-emphasised Response- Bandwidth	.. 300Hz to 3kHz (WB & MB) .. 300Hz to 2.55kHz (NB)
Below Limiting	.. within +1, -3dB of a 6dB/octave pre-emphasis characteristic
Flat Response	.. within +1, -2dB of output at 1kHz
Above Limiting Response	.. within +1, -2dB of a flat response (ref. 1kHz)
Distortion	.. 2%
Hum And Noise:	
Wide Bandwidth	.. -55dB (300Hz to 3kHz [EIA]) typical
Mid Bandwidth	.. -53dB (CEPT)
Narrow Bandwidth	.. -50dB (CEPT)
Compressor (optional):	
Attack Time	.. 10ms
Decay Time	.. 800ms
Range	.. 50dB

### 1.2.4.3 CTCSS

Standard Tones	.. all 37 EIA group A, B and C tones plus 13 commonly used tones
Frequency Error (from EIA tones)	.. 0.08% max.
Generated Tone Distortion	.. 1.2% max.
Generated Tone Flatness	.. flat across 67 to 250.3Hz to within 1dB
Modulation Level	.. adjustable
Modulated Distortion	.. <5%

## 1.2.5 Microcontroller

### Auxiliary Ports:

Open Drain Type	.. capable of sinking 2.25mA via 2k2Ω
V <sub>ds</sub> max.	.. 5V

## 1.3 Product Codes

The three groups of digits in the T830 Series II product code provide information about the model, type and options fitted, according to the conventions described below.

The following explanation of T830 Series II product codes is not intended to suggest that any combination of features is necessarily available in any one product. Consult your nearest Tait Dealer or Subsidiary for more information regarding the availability of specific models, types and options.

### Model

The Model group indicates the basic function of the product, as follows:

<u>T83X</u> -XX-XXXX	T835 receiver
	T836 25W transmitter
	T837 exciter
	T838 50W power amplifier
	T839 100W power amplifier

### Type

The Type group uses two digits to indicate the basic RF configuration of the product.

The first digit in the Type group designates the frequency range:

T83X- <u>1</u> X-XXXX	'1' for 136-156MHz
	'2' for 148-174MHz

The second digit in the Type group indicates the channel spacing:

T83X- <u>0</u> X-XXXX	'0' for wide bandwidth (25kHz)
	'3' for mid bandwidth (20kHz)
	'5' for narrow bandwidth (12.5kHz)

### Options

T83X-XX- <u>XXXX</u>	The Options group uses four digits and/or letters to indicate any options that may be fitted to the product. This includes standard options and special options for specific customers. '0000' indicates a standard Tait product with no options fitted. The large number of options precludes listing them here.
----------------------	---

## 1.5 T837 Standard Product Range

The following table lists the range of standard T837 types (i.e. no options fitted) available at the time this manual was published. Consult your nearest Tait Dealer or Subsidiary for more information.

Frequency Range (MHz)		136-156			
Deviation (kHz)		2.5	2.5	4	5
TCXO <sup>a</sup>	±2.5ppm -30°C to +60°C	•	•	•	•
Exciter Type: T837-		16-0000 <sup>b</sup>	15-0000	13-0000	10-0000

Frequency Range (MHz)		148-174			
Deviation (kHz)		2.5	2.5	4	5
TCXO <sup>a</sup>	±2.5ppm -30°C to +60°C	•	•	•	•
Exciter Type: T837-		26-0000 <sup>b</sup>	25-0000	23-0000	20-0000

a. A TCXO with a stability of ±1ppm (0°C to +60°C) is available to suit specific requirements. Contact your nearest authorised Tait Dealer or Subsidiary for further details.

b. United States market only.

You can identify the exciter type by checking the product code printed on a label on the rear of the chassis (Figure 1.1 in Part A shows typical labels). You can further verify the exciter type by checking the placement of an SMD resistor in the table that is screen printed onto the PCB (refer to Section 6.1 for more details).

## 2 T836/837 Circuit Operation

This section provides a basic description of the circuit operation of the T836 transmitter and T837 exciter.

**Note:** Unless otherwise specified, the term "PGM800Win" used in this and following sections refers to version 2.00 and later of the software.

Refer to Section 6 where the parts lists, grid reference index and diagrams will provide detailed information on identifying and locating components and test points on the main PCB. The parts list and diagrams for the VCO PCB are in Part E.

The following topics are covered in this section.

Section	Title	Page
2.1	Introduction	2.3
2.2	Microcontroller	2.4
2.3	Synthesised Local Oscillator	2.5
2.3.1	Two Point Modulation	2.6
2.4	VCO	2.7
2.4.1	VCO Supply	2.7
2.5	Audio Processor	2.8
2.5.1	General	2.8
2.5.2	Audio Inputs	2.8
2.5.3	Keying Inputs	2.9
2.5.4	Compressor (Automatic Level Control (ALC))	2.9
2.5.5	Outputs To Modulators	2.9
2.6	Power Supply & Regulator Circuits	2.10
2.7	Transmit Timers	2.11
2.8	T836 Drive Amplifier & PA	2.12
2.9	T837 Exciter Drive Amplifier	2.13

## 2.1 Introduction

The individual circuit blocks which make up the T836 and T837 are:

- synthesiser
- VCO
- audio processor
- drive amplifier
- power amplifier (T836 only)
- voltage regulators.

Each of these circuit blocks is set in its own shielded compartment, formed as an integral part of the main chassis.

The configuration of the circuit blocks may be seen on a functional level in Figure 2.1 and Figure 2.2. Refer to the circuit diagrams in Section 6.2 (T836) or 6.3 (T837) for more detail.

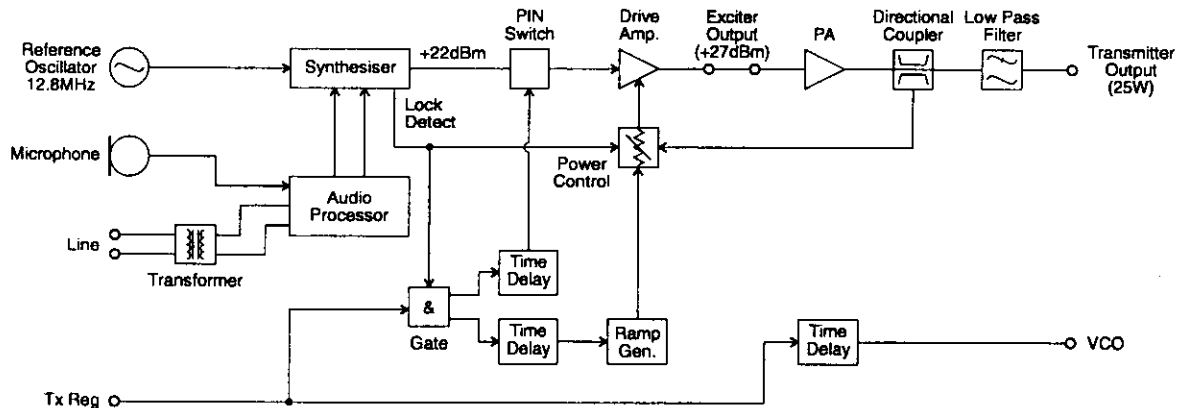

Figure 2.1 T836 High Level Block Diagram

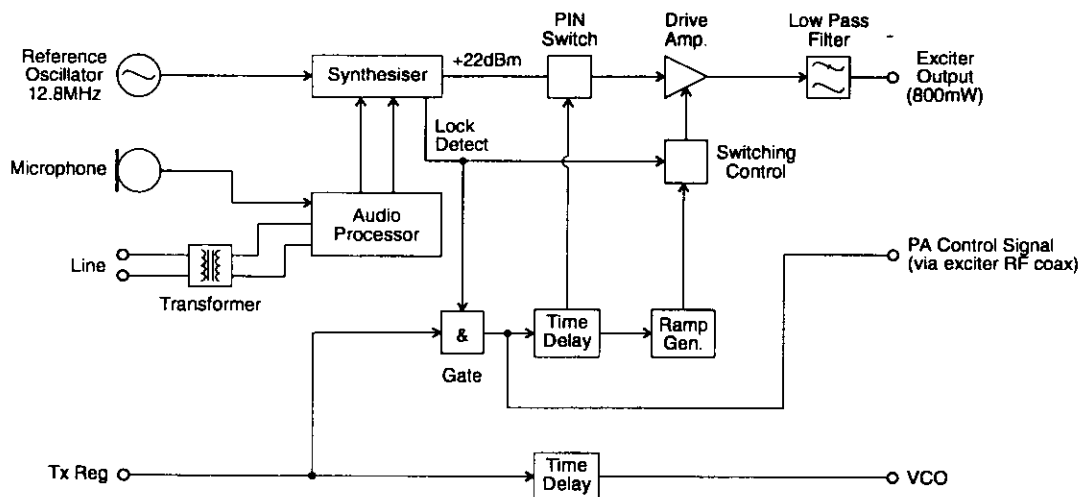

Figure 2.2 T837 High Level Block Diagram



## 2.3 Synthesised Local Oscillator

(Refer to the synthesiser circuit diagram (sheet 7) in Section 6.2 or 6.3 and the VCO circuit diagram in Part E.)

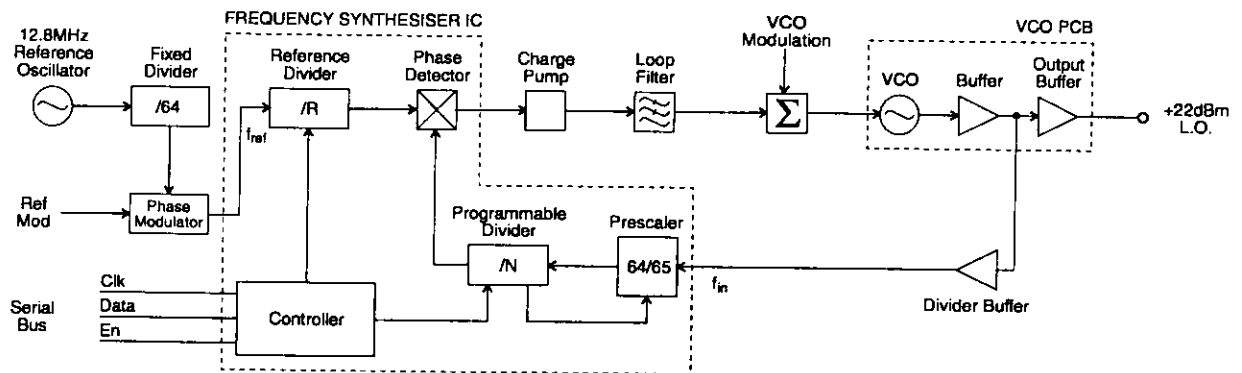

Figure 2.4 T836/837 Synthesiser Block Diagram

The synthesiser (IC740) employs a phase-locked loop (PLL) to lock a voltage controlled oscillator (VCO) to a given reference frequency. The synthesiser receives the divider information from the control microprocessor via a 3 wire serial bus (clock, data, enable). When the data has been latched in, the synthesiser processes the incoming signals from the VCO buffer ( $f_{in}$ ) and the phase modulator ( $f_{ref}$ ).

A reference oscillator at 12.8MHz (IC700) is buffered (IC710 pins 3 & 4) and divided down to 200kHz (IC730). This 200kHz square wave is then summed with the modulating audio and passed to an integrator (IC720 pins 9 & 8, Q710, Q720). This produces a ramping waveform which is centred around a DC level determined by the incoming audio. IC720 pins 5 & 6 perform as a comparator, ultimately producing a phase-modulated 200kHz square wave. This is followed by another phase shifting stage (IC720 pins 3 & 4, Q730, Q740), before being divided down to 6.25kHz or 5kHz within the synthesiser IC (IC740).

A buffered output of the VCO (Q795) is divided with a prescaler and programmable divider which is incorporated into the synthesiser chip (IC740). This signal is compared with the phase modulated reference signal at the phase detector (also part of the synthesiser chip). The phase detector outputs drive a balanced charge pump circuit (Q760, Q770, Q775, Q780, Q785) and active loop filter (IC750 pins 5, 6 & 7) which produces a DC voltage between 0V and 20V to tune the VCO. This VCO control line is further filtered to attenuate noise and other spurious signals. Note that the VCO frequency increases with increasing control voltage.

If the synthesiser loop loses lock, a pulsed signal appears at LD (pin 2) of IC740. This signal is filtered and buffered by IC750 pins 1, 2 & 3, producing the Lock-Detect signal used to shut off the power supply to the drive amplifier. IC750 pin 1 is at 20V when the synthesiser is out of lock.

## 2.4 VCO

(Refer to the VCO circuit diagram in Part E.)

The VCO transistor (Q1) operates in a common source configuration, with an LC tank circuit coupled between its gate and drain to provide the feedback necessary for oscillation. The VCO control voltage from the loop filter (IC750 pin 7) is applied to the vari-caps (D1-D4) to facilitate tuning within an 8MHz band of frequencies. A trimcap (CV1) is used for coarse tuning of the VCO. The output from the oscillator circuit drives a cas-code amplifier stage (Q2, Q3) which supplies +10dBm (typically) to a further stage of amplification, Q5. This is the final amplifier on the VCO PCB, and delivers +22dBm (typically) to the exciter drive amplifier.

A low level "sniff" is taken from the output of Q3 and used to drive the divider buffer (Q795) for the synthesiser (IC740).

The VCO operates at the actual output frequency of the exciter, i.e. there are no multiplier stages. The VCO is modulated by superimposing the audio signal onto the control voltage and by phase modulating the reference signal.

### 2.4.1 VCO Supply

The VCO is supplied from two switched +9V supplies under the control of the Tx-Reg. supply.

The VCO (Q1) and buffer amplifier (Q2 & Q3) are supplied from one +9V switched supply by Q540 via the capacitor multiplier (Q550, C550).

The output amplifier is supplied from the other +9V supply by Q520, Q530, and Q510.

A delay circuit holds the VCO on for a short time after the Tx-Reg. supply has been switched off. This is to allow the RF power circuits (both exciter and PA) to ramp down in the correct manner before the VCO is switched off.

### 2.5.3 Keying Inputs

There are four ways to key the exciter:

- pulling the Tx-Key line low (pin 13 on D-range 1 [PL100]) at the rear of the set);
- pushing the "Carrier" button on the front panel - this will inhibit all audio;
- using the PTT button on the local microphone, disabling audio from the line;
- via the opto-key inputs (pins 11 and 12 on D-range 1 [PL100]) when electrical isolation is required. This features a constant current sink (Q270) to ensure reliable activation of the opto-coupler (IC250) at low keying voltages.

### 2.5.4 Compressor (Automatic Level Control (ALC))

The input signal is fed via a current controlled attenuator (Q230, Q220) to a high gain stage (IC230) from which the output signal is taken. This signal is passed to a comparator (IC230) which toggles whenever the audio signal exceeds a DC threshold determined by RV220. Thus, the comparator produces a square wave whose mark-space ratio is determined by the amplitude of the audio signal. This square wave pumps up the reservoir capacitor (C233) which controls the attenuator (Q230, Q220), thus completing the feedback loop.

The compression level is set by adjustment of the comparator threshold (RV220).

**Note:** Although the high dynamic range of the compressor allows the use of very low audio signal levels, such conditions will be accompanied by a degradation of the signal-to-noise ratio. Very low audio input levels should therefore be avoided where possible.

### 2.5.5 Outputs To Modulators

The output signal from the limiter (IC210, IC230) is added with a CTCSS tone at a summing amplifier (IC260). The signal is then low pass filtered (IC260) and split to supply the two modulators.

Since the VCO modulator is a true frequency modulator, its audio is simply buffered (IC260). The reference modulator, however, is a phase modulator and its audio must first be integrated (IC210).

It is vital that the audio levels to the modulators are accurately set, *relative to each other*. Hence the inclusion of level adjustment in the reference modulator path. Once set, adjustments to absolute deviation may be made only via the deviation digital pot. (IC220 - adjustable via PGM800Win).

## 2.7 Transmit Timers

The transmit tail timer, transmit timeout timer and transmit lockout timer can all be set from PGM800Win. The fields for setting these are found on the system information page. These three timers operate as follows (refer also to Figure 2.8):

Timer	Function	Adjustment
Transmit Tail	Sets the tail time during which the transmitter stays keyed after the external key source has been removed.	0-5 seconds in 100ms steps
Transmit Timeout	Sets the maximum continuous transmission time. Once the timer has timed out, the transmitter must be keyed again, unless prevented by the transmit lockout timer.	0-300 seconds in 10 second steps
Transmit Lockout	Sets the period of time that must elapse after a timeout before the transmitter can re-transmit. Once the timer has timed out, the transmitter can be keyed again.	0-60 seconds in 10 second steps

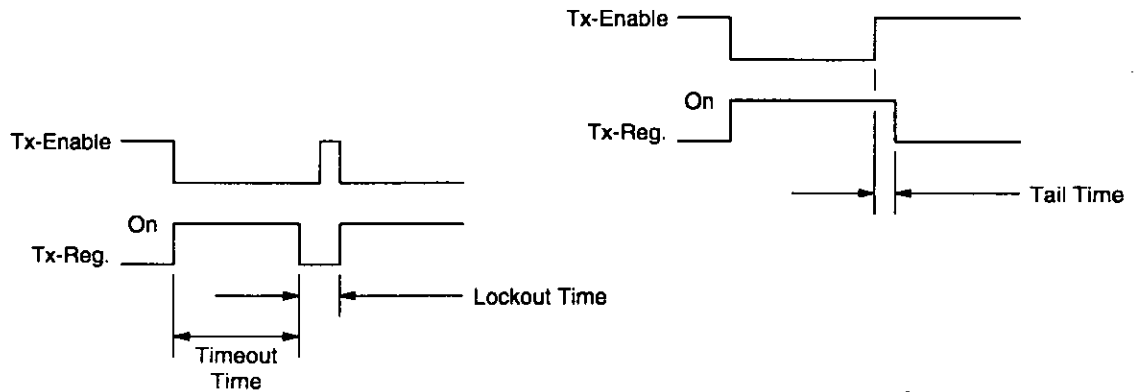

Figure 2.8 T836/837 Transmit Timers

## 2.9 T837 Exciter Drive Amplifier

(Refer to Figure 2.2 and the exciter circuit diagram (sheet 3) in Section 6.3.)

A two-stage, wide band amplifier (Q365, Q370) provides an output level of approximately 800mW (+29dBm) for an input of 170mW (+22dBm) from the VCO. IC330 pins 5, 6 & 7, Q310, and Q315 provide a 10.5V regulated supply for the exciter.

To reduce the spurious output level when the synthesiser is out-of-lock, the Tx-Reg. and Lock-Detect signals are gated to inhibit the exciter control circuit and to switch off the RF signal at the input to the drive amplifier. This is achieved by a PIN switch attenuator (D340, D350, D360).

Cyclic keying control is provided by additional circuitry consisting of several time delay, ramp and gate stages:

- Q305, IC330 pins 5, 6 & 7      power ramping
- Q340, Q345      Tx-Reg. and Lock-Detect gate
- Q320, Q325, Q330, Q335      delay and PIN switch drive.

This is to allow the RF power circuits (both exciter and PA) to ramp up and down in a controlled manner so that minimal adjacent channel interference is generated during the transition.

R359, R360 and R362 form a 6dB attenuator to provide good VCO/drive amplifier isolation.

The output attenuator (R392, R390, R394, R396) assists in reducing exciter/PA interaction while also ensuring a good match for Q370.

**Note:** The exciter provides a DC control signal to the PA via the RF coax. This is injected via L390.

### 3 T836/837 Initial Tuning & Adjustment

The following section describes both short and full tuning and adjustment procedures and provides information on:

- channel programming
- selecting required audio links
- synthesiser alignment
- PA alignment (T836 only)
- modulator adjustment
- limiter adjustment
- setting line level
- compressor adjustment
- timer adjustment.

**Note:** Unless otherwise specified, the term "PGM800Win" used in this and following sections refers to version 2.00 and later of the software.

Refer to Figure 4.4 and Figure 4.5 which show the location of the main tuning and adjustment controls. Refer also to Section 6 where the parts lists, grid reference index and diagrams will provide detailed information on identifying and locating components and test points on the main PCB. The parts list and diagrams for the VCO PCB are in Part E.

Section	Title	Page
3.1	Introduction	3.3
3.2	Channel Programming	3.3
3.3	Test Equipment Required	3.4
3.4	Short Tuning Procedure	3.5
3.4.1	Introduction	3.5
3.4.2	Synthesiser Alignment	3.5
3.4.3	Output Power Adjustment (T836 Only)	3.5
3.4.4	Two Point Modulation Adjustment	3.6
3.4.5	FM Deviation (Limiter) Adjustment	3.6
3.4.6	Line-in Level Adjustment	3.7
3.5	Audio Processor Links	3.8
3.5.1	Link Details	3.8
3.5.2	Typical Options	3.8
3.6	Synthesiser Alignment	3.9

## 3.1 Introduction

When you receive your T836 transmitter or T837 exciter it will be run up and working on a particular frequency (the "default channel")<sup>1</sup>. If you want to switch to a frequency that is within the 8MHz switching range (i.e.  $\pm 4$ MHz from the factory programmed frequency), you should only need to reprogram the transmitter/exciter with the PGM800Win software (refer to the PGM800Win programming kit and Section 3.2 below).

However, if you want to switch to a frequency outside the 8MHz switching range, you will have to reprogram and re-tune the transmitter/exciter to ensure correct operation. In this case you should carry out the short tuning procedure described in Section 3.4.

If you have carried out repairs or other major adjustments, you must carry out the full tuning and adjustment procedure described in this section (except for Section 3.4).

## 3.2 Channel Programming

You can program up to 128 channel frequencies into the transmitter/exciter's EEPROM memory (IC820) by using the PGM800Win software package and an IBM™ PC. You can also use PGM800Win to select the transmitter/exciter's current operating frequency (or "default channel").

If the transmitter/exciter is installed in a rack frame, you can program it via the programming port in the speaker panel. However, you can also program the transmitter/exciter before it is installed in a rack frame as follows:

- by using a T800-01-0010 calibration test unit;
- via D-range 1;
- via D-range 2 (standard T800-03-0000 auxiliary D-range only);
- via SK805 (internal Micromatch connector).

If you do not use the T800-01-0010, you will have to connect the PC to the transmitter/exciter via a module programming interface (such as the T800-01-0004).

For a full description of the channel programming procedure, refer to the PGM800Win programming software user's manual.

**Note:** When an auxiliary D-range kit (D-range 2 - T800-03-0000) is fitted, you can also select a channel with an external switch, such as the DIP switch on the rack frame backplane PCB. Refer to Part C in the T800 Series Ancillary Equipment Service Manual (M800-00-101 or later issue) or consult your nearest Tait Dealer or Subsidiary for further details.

---

1. Use the "Read Module" function in PGM800Win to find out what the default channel is.

## 3.4 Short Tuning Procedure

Use this procedure only if you want to reprogram the T836/837 to a frequency outside the 8MHz switching range and do not intend to carry out any other major adjustments or repairs.

### 3.4.1 Introduction

Reprogram the operating frequency as described in the PGM800Win programming kit (refer to Section 3.2).

Remove the top cover (nearest the handle).

Set up the test equipment as described in Section 3.3.

Set the links in the audio processor section as required (refer to Section 3.5).

### 3.4.2 Synthesiser Alignment

- Connect a high impedance voltmeter to PLA-1 or the junction of L1 & R1 in the VCO (this measures the synthesiser loop voltage).
- Key the transmitter by earthing the Tx-Key line.
- **Single Channel** Tune VCO trimmer CV1 for a synthesiser loop voltage of 9V.
- **Multichannel** Tune VCO trimmer CV1 for a synthesiser loop voltage of 9V on the middle channel.  
If there is no middle channel, tune CV1 so that the channels are symmetrically placed around a loop voltage of 9V.  
All channels should lie within the upper and lower limits of 13V and 5V respectively.  
Do not attempt to program channels with a greater frequency separation than the specified switching range of 8MHz.

### 3.4.3 Output Power Adjustment (T836 Only)

Connect an RF power meter to the output socket and key the transmitter.

Turn RV320 (power adjust) fully clockwise.

Tune CV451 (output power trim) for maximum output power and check that this is >30W.

Adjust RV320 for the required output power (between 5 and 25W).

Readjust CV451 to reduce the supply current by up to 0.5A.



Adjust RV210 (line sensitivity) fully clockwise and key the transmitter by earthing the Tx-Key line. Adjust "deviation" via PGM800Win to set the peak deviation to  $\pm 4.7\text{kHz}$  ( $\pm 3.8\text{kHz}$ ) [ $\pm 2.3\text{kHz}$ ] (you can use either the mouse or up and down arrow keys).

Sweep the audio frequency from 100Hz to 4kHz and ensure that the maximum deviation does not exceed 4.7kHz ( $\pm 3.8\text{kHz}$ ) [2.3kHz]. Readjust "deviation" if necessary via PGM800Win.

### 3.4.6 Line-in Level Adjustment

Set the injected signal at the line input to the required line level (typically -10 to -20dBm).

Adjust RV210 (line sensitivity) to provide  $\pm 3\text{kHz}$  ( $\pm 2.4\text{kHz}$ ) [ $\pm 1.5\text{kHz}$ ] deviation.

## 3.6 Synthesiser Alignment

- Ensure that the T836/837 has been programmed with the required frequencies using PGM800Win software.
- **Single Channel**      Select a channel using PGM800Win.  
**Multichannel**      Select the middle channel via PGM800Win.
- Connect a high impedance voltmeter to PL4-1 or the junction of L1 and R1 in the VCO (this measures the synthesiser loop voltage).
- Key the transmitter by earthing the Tx-Key line.
  - Single Channel**      Tune VCO trimmer CV1 for a synthesiser loop voltage of 9V.
  - Multichannel**      Tune VCO trimmer CV1 for a synthesiser loop voltage of 9V on the middle channel.  
 If there is no middle channel, tune CV1 so that the channels are symmetrically placed around a loop voltage of 9V.  
 All channels should lie within the upper and lower limits of 13V and 5V respectively.  
 Do not attempt to program channels with a greater frequency separation than the specified switching range (8MHz).
- Check that the exciter output power is:
 

T836	500mW +200, -100mW
T837	800mW $\pm$ 200mW.
- Measure the exciter output frequency and adjust the TCXO (IC700) trimmer if required.



**Caution:**

This trimmer is susceptible to physical damage. Do not exert a downward force of more than 500g (11lb) when adjusting.

## 3.9 Audio Processor

### 3.9.1 Two Point Modulation

The T836 and T837 utilise two point modulation to obtain a wide audio bandwidth independent of the synthesiser loop filter response. This is achieved by simultaneously frequency modulating the VCO and phase modulating the synthesiser reference frequency. The relative signal levels fed to the two modulators are quite critical and cause interaction when setting up.

Both modulating signals require readjustment when the exciter is shifted in frequency greater than the switching range (i.e.  $\Delta F > \pm 4\text{MHz}$ ).

**Note 1:** In this and following sections deviation settings are given first for wide bandwidth sets, followed by settings in brackets for mid bandwidth sets ( ) and narrow bandwidth sets [ ].

**Note 2:** Reference modulation and limiter adjustment are controlled by PGM800Win. Electronic potentiometers (256 step) are used to allow channel-by-channel adjustment of deviation and two point modulation.

**Note 3:** To optimise the modulation response across the switching range, repeat steps 1-4 below for each channel that will be used (usually needed only for data applications). In applications where the modulation response is less critical (e.g. voice use only), carry out steps 1-4 below on the middle channel and cut and paste the value to all other channels.

### 3.9.2 Modulator Adjustment

1. Inject an audio signal of 600Hz 1.5V rms (+5dBm) into the CTCSS input (D-range 1 (PL100) pin 8).

Key the transmitter by earthing the Tx-Key line.

2. Adjust the output from the audio generator to obtain  $\pm 3\text{kHz}$  ( $\pm 2.4\text{kHz}$ ) [ $\pm 1.5\text{kHz}$ ] deviation at 600Hz.
3. Change the input frequency to 120Hz and adjust "reference modulation" via PGM800Win to obtain  $\pm 3\text{kHz}$  ( $\pm 2.4\text{kHz}$ ) [ $\pm 1.5\text{kHz}$ ] deviation.
4. Change the input frequency back to 600Hz.

Repeat steps 2 and 3 above until the deviations achieved at the two input frequencies are within 0.2dB of each other. You will need to do this at least four times.

5. Sweep the audio between 50 and 300Hz for peaks.

**Note:** A peak between 50 and 300Hz will indicate a fault condition, i.e:

- incorrect set-up
- or - modulation circuitry fault.

The specification window is  $\pm 1\text{dB}$  relative to 150Hz from 65 to 260Hz.

Check that  $\pm 3\text{kHz}$  ( $\pm 2.4\text{kHz}$ ) [ $\pm 1.5\text{kHz}$ ] deviation is still available.

Slowly increase the audio input level until the demodulated waveform shows significant signs of clipping (approximately  $\pm 4.5\text{kHz}$  ( $\pm 3.6\text{kHz}$ ) [ $\pm 2.3\text{kHz}$ ] deviation).

Adjust RV220 anticlockwise until the demodulated waveform is just clipping (approximately  $\pm 4\text{kHz}$  ( $\pm 3.2\text{kHz}$ ) [ $\pm 2\text{kHz}$ ] deviation).

Increase the input level to  $-10\text{dBm}$  and check that the test tone is still held just into clipping. The input line level should be typically  $-10$  to  $-20\text{dBm}$ .

### 3.9.5.2 Compressor On Microphone Input Only

Key the transmitter by earthing the Tx-Key line and plug a microphone jack into the front panel socket.

Adjust RV220 (compression level) fully clockwise.

Acoustically couple the microphone to a tone box ( $1\text{kHz}$ ) and close the PTT switch.

Increase the audio level until the demodulated waveform shows significant signs of clipping (approximately  $\pm 4.5\text{kHz}$  ( $\pm 3.6\text{kHz}$ ) [ $\pm 2.3\text{kHz}$ ] deviation).

Adjust RV220 anticlockwise until the demodulated waveform is just clipping (approximately  $\pm 4\text{kHz}$  ( $\pm 3.2\text{kHz}$ ) [ $\pm 2\text{kHz}$ ] deviation).

Increase the audio level by  $10\text{dB}$  and verify that the test tone is held just into clipping.

Whistle steadily into the microphone, checking that approximately  $\pm 4\text{kHz}$  ( $\pm 3.2\text{kHz}$ ) [ $\pm 2\text{kHz}$ ] deviation is produced. The modulated waveform should be basically sinusoidal.

Speak into the microphone, checking that the modulation peaks reach about  $\pm 5\text{kHz}$  ( $\pm 4\text{kHz}$ ) [ $\pm 2.5\text{kHz}$ ] deviation.

As the line is to be used without compression, set RV210 (line sensitivity) as described in Section 3.9.4.

### 3.9.5.3 Compressor On Both Line & Microphone Inputs

Set up as described in Section 3.9.5.1.

## 4 T836/837 Functional Testing

The following test procedures will confirm that the T836/837 has been tuned and adjusted correctly and is fully operational.

**Note 1:** In this and following sections deviation settings are given first for wide bandwidth sets, followed by settings in brackets for mid bandwidth sets ( ) and narrow bandwidth sets [ ].

**Note 2:** Unless otherwise specified, the term "PGM800Win" used in this and following sections refers to version 2.00 and later of the software.

Refer to Figure 4.4 and Figure 4.5 for the location of the main tuning and adjustment controls, and to Section 3.3 for the test equipment set-up. Refer also to Section 6 where the parts lists, grid reference index and diagrams will provide detailed information on identifying and locating components and test points on the main PCB. The parts list and diagrams for the VCO PCB are in Part E.

The following topics are covered in this section.

Section	Title	Page
4.1	Current Consumption	4.3
4.2	Output Power	4.3
4.3	Output Frequency	4.3
4.4	Timers	4.3
4.5	Frequency Response	4.4
4.6	Audio Level Input Sensitivity	4.7
4.7	CTCSS Encoder	4.7

Figure	Title	Page
4.1	T836/837 Transmit Timers	4.4
4.2	T836/837 Pre-emphasis Response	4.5
4.3	T836/837 Limiting Response	4.6
4.4	T836 Main Tuning & Adjustment Controls	4.9
4.5	T837 Main Tuning & Adjustment Controls	4.11

## 4.1 Current Consumption

Connect the T836/837 to a 13.8V power supply.

Connect an RF power meter to the T836/837 output socket.

Check that the current in the 13.8V power cable is less than 150mA.

Key the T836/837 by earthing the Tx-Key line (the carrier "On" LED should light).

**T836 Only:** Adjust RV320 (power adjust) to obtain 25W output power.

Check that the current is as follows:

T836	<4.5A
T837	<600mA.

## 4.2 Output Power

Connect an RF power meter to the T836/837 output socket.

Key the T836/837 by earthing the Tx-Key line.

Check that:

T836	the output power adjusts to >30W with RV320 (power adjust) turned fully clockwise
T837	the output power is 800mW $\pm$ 200mW.

## 4.3 Output Frequency

Connect the T836/837 output to a frequency counter via an attenuator pad:

T836	40dB pad
T837	20dB pad.

Measure the output frequency and, if necessary, adjust the TCXO (IC700) to trim to the nominal frequency ( $\pm$ 100Hz).

## 4.4 Timers

The transmit tail timer, transmit timeout timer and transmit lockout timer can all be set from PGM800Win. The fields for setting these are found on the system information page. These three timers operate as follows (refer also to Figure 4.1):

### Wide Bandwidth

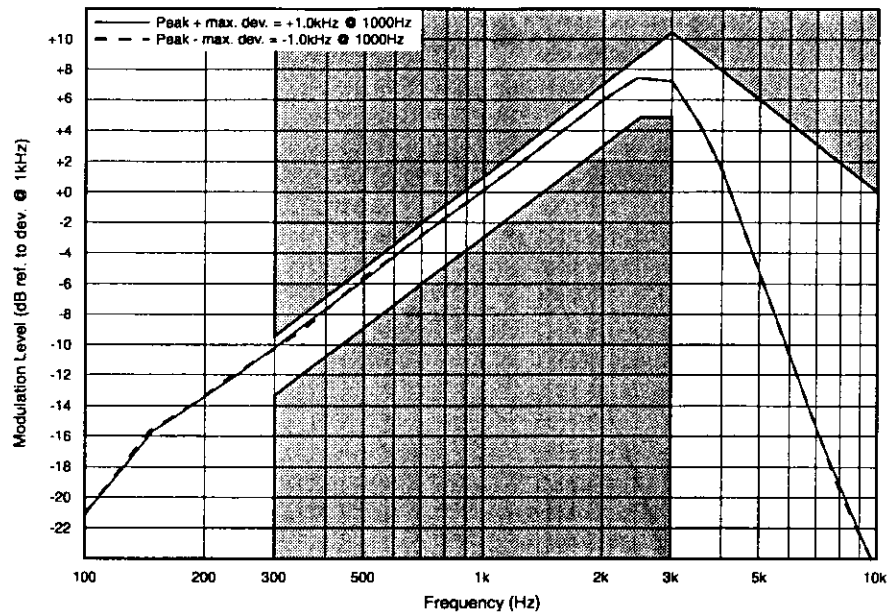

### Mid Bandwidth

The mid bandwidth graph is the same shape as the wide bandwidth graph. The deviation figures are as follows:

$$\begin{aligned} \text{peak + max. deviation} &= +0.8\text{kHz} \\ \text{peak - max. deviation} &= -0.8\text{kHz}. \end{aligned}$$

### Narrow Bandwidth

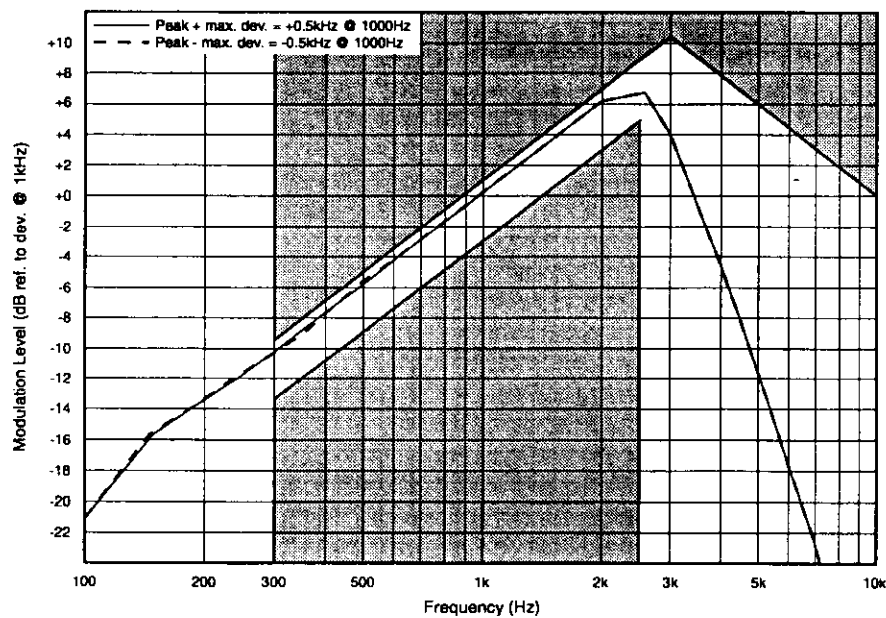

Figure 4.2 T836/837 Pre-emphasis Response

## 4.6 Audio Level Input Sensitivity

- Adjust RV210 (line sensitivity) fully clockwise.
- Check that the input sensitivities are better than those specified below:

Line Input	600 ohms, $\pm 3\text{kHz}$ ( $\pm 2.4\text{kHz}$ ) [ $\pm 1.5\text{kHz}$ ] deviation at 1kHz:	
	with compressor	-50dBm
	without compressor	-30dBm
Microphone Input	600 ohms, $\pm 3\text{kHz}$ ( $\pm 2.4\text{kHz}$ ) [ $\pm 1.5\text{kHz}$ ] deviation at 1kHz:	
	with compressor	-75dBm
	without compressor	-55dBm
CTCSS Input	1kHz deviation at 150Hz	500mV rms

**Note:** A degraded signal to noise ratio can be expected with the compressor selected. The extent of the degradation is dependent on the audio input level.

## 4.7 CTCSS Encoder

Program a CTCSS tone on the set channel using PGM800Win.

Key T836/837 with the front panel "Carrier" switch.

Adjust RV805 (CTCSS level adjust) to give 10% system deviation.

Reset the maximum deviation as per Section 3.9.3.



## 5 T836/837 Fault Finding

The following test procedures and fault finding flow charts may be used to help locate a hardware problem, however they are by no means a complete fault finding procedure. If you still cannot trace the fault after progressing through them in a logical manner, contact your nearest Tait Dealer or Subsidiary. If necessary, you can get additional technical help from the Customer Support Group, Radio Systems Division, Tait Electronics Ltd, Christchurch, New Zealand (full contact details are on page 2).

**Note 1:** In this and following sections deviation settings are given first for wide bandwidth sets, followed by settings in brackets for mid bandwidth sets ( ) and narrow bandwidth sets [ ].

**Note 2:** Unless otherwise specified, the term "PGM800Win" used in this and following sections refers to version 2.00 and later of the software.

Refer to Section 6 where the parts lists, grid reference index and diagrams will provide detailed information on identifying and locating components and test points on the main PCB. The parts list and diagrams for the VCO PCB are in Part E.

The following topics are covered in this section

Section	Title	Page
5.1	Visual Checks	5.3
5.2	Component Checks	5.3
5.3	Front Panel LED Indicator	5.3
5.4	DC Checks	5.4
5.4.1	Power Rails	5.4
5.4.2	VCO Locking	5.4
5.5	RF Checks	5.5
5.5.1	T836 Drive Power	5.5
5.5.2	T836 PA Output Power	5.5
5.5.3	T837 Output Power	5.5
5.5.4	Audio And Modulation	5.6
5.6	PGM800Win Generated Errors	5.7

## 5.1 Visual Checks

Remove the covers from the T836/837 and inspect the PCB for damaged or broken components, paying particular attention to the surface mounted devices (SMD's).

Check for defective solder joints. If repair or replacement is considered necessary, refer to Section 3 of Part A.

## 5.2 Component Checks

If you suspect a transistor is faulty, you can assess its performance by measuring the forward and reverse resistance of the junctions. Unless the device is completely desoldered, first make sure that the transistor is not shunted by some circuit resistance. Use a good quality EVM (e.g. Fluke 75) for taking the measurements (or a 20k ohm/V or better multimeter, using only the medium or low resistance ranges).

The collector current drawn by multi-junction transistors is a further guide to their performance.

If an IC is suspect, the most reliable check is to measure the DC operating voltages. Due to the catastrophic nature of most IC failures, the pin voltages will usually be markedly different from the recommended values in the presence of a fault. The recommended values can be obtained from either the circuit diagram or the component data catalogue.

## 5.3 Front Panel LED Indicator

The green "Supply" LED on the T836/837 front panel will flash according to the conditions described in the following table:

Flash Rate	Condition
<p style="text-align: center;">fast</p> <p style="text-align: center;">- - - - -</p> <p style="text-align: center;">(1/3 sec. on/1/3 sec. off approx.)</p>	T836/837 is linked with PGM800Win
<p style="text-align: center;">unequal</p> <p style="text-align: center;">- - - - -</p> <p style="text-align: center;">(1/3 sec. on/1 sec. off approx.)</p>	microcontroller has detected an internal communications error - refer to Section 5.7.1

Where two or more conditions occur at the same time, the precedence is in the order shown above (i.e. T836/837 linked has the highest priority, followed by internal error).

## 5.5 RF Checks

In-circuit RF levels may be measured with an RF probe on which the earth lead has been shortened to a minimum (i.e. 13mm). Refer to the circuit diagrams for typical levels.

Figure 5.1 shows a suitable RF probe circuit..

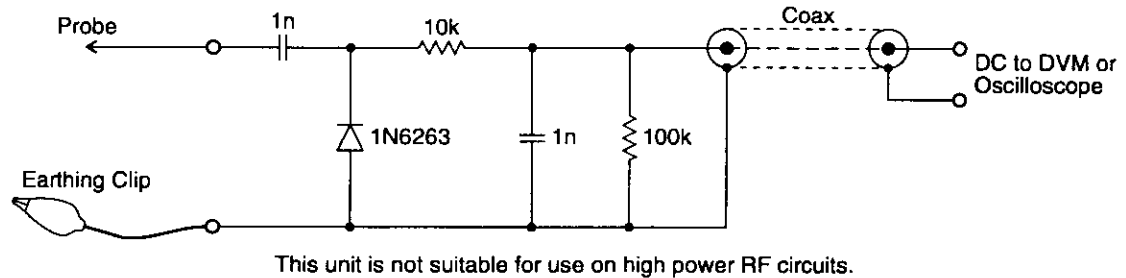

**Figure 5.1 RF Diode Probe Circuit**

### 5.5.1 T836 Drive Power

Refer to the drive amplifier fault finding chart (Section 5.7.4).

Ensure that the VCO locks (refer to Section 5.4.2).

Connect the drive output to a power meter and key the transmitter.

Check that the output power is between 600 and 1000mW.

**Note:** If the synthesiser is out of lock, the lock detector (synthesiser IC740 and comparator IC750) will prevent the RF signal from reaching the PA by switching the supply to the exciter amplifier (Q340, Q345).

### 5.5.2 T836 PA Output Power

Reconnect the drive output to the PA input.

Connect the PA to a power meter and key the transmitter.

Check that the output power is >30W with RV320 (power adjust) adjusted fully clockwise.

### 5.5.3 T837 Output Power

Refer to the exciter drive amplifier fault finding chart (Section 5.7.6).

Ensure that the VCO locks (refer to Section 5.4.2).

## 5.6 PGM800Win Generated Errors

The following errors are those most likely to occur using PGM800Win. Refer to the PGM800Win software user's manual for a complete list of error messages.

### **Channel Switch Set**

The programmed default channel change was not accepted by the base station because a channel is selected externally. Try turning the external channel switch off to change the default channel in PGM800Win.

### **Synth Out Of Lock**

The synthesiser received incorrect data, or the data was corrupted. Enter a frequency within the VCO switching range, or tune the VCO.

### **Internal Error**

Data could not be read from the base station due to an internal error. Check for shorts or open circuits on the SDA, SCK, SYNTH and EPOT lines. The SDA, SCK and SYNTH are normally high, and the EPOT is normally low.

### **Write/Read To An Unlinked Module**

The link to the module does not exist. Undefined error.

## 5.7.1.2 Serial Communication

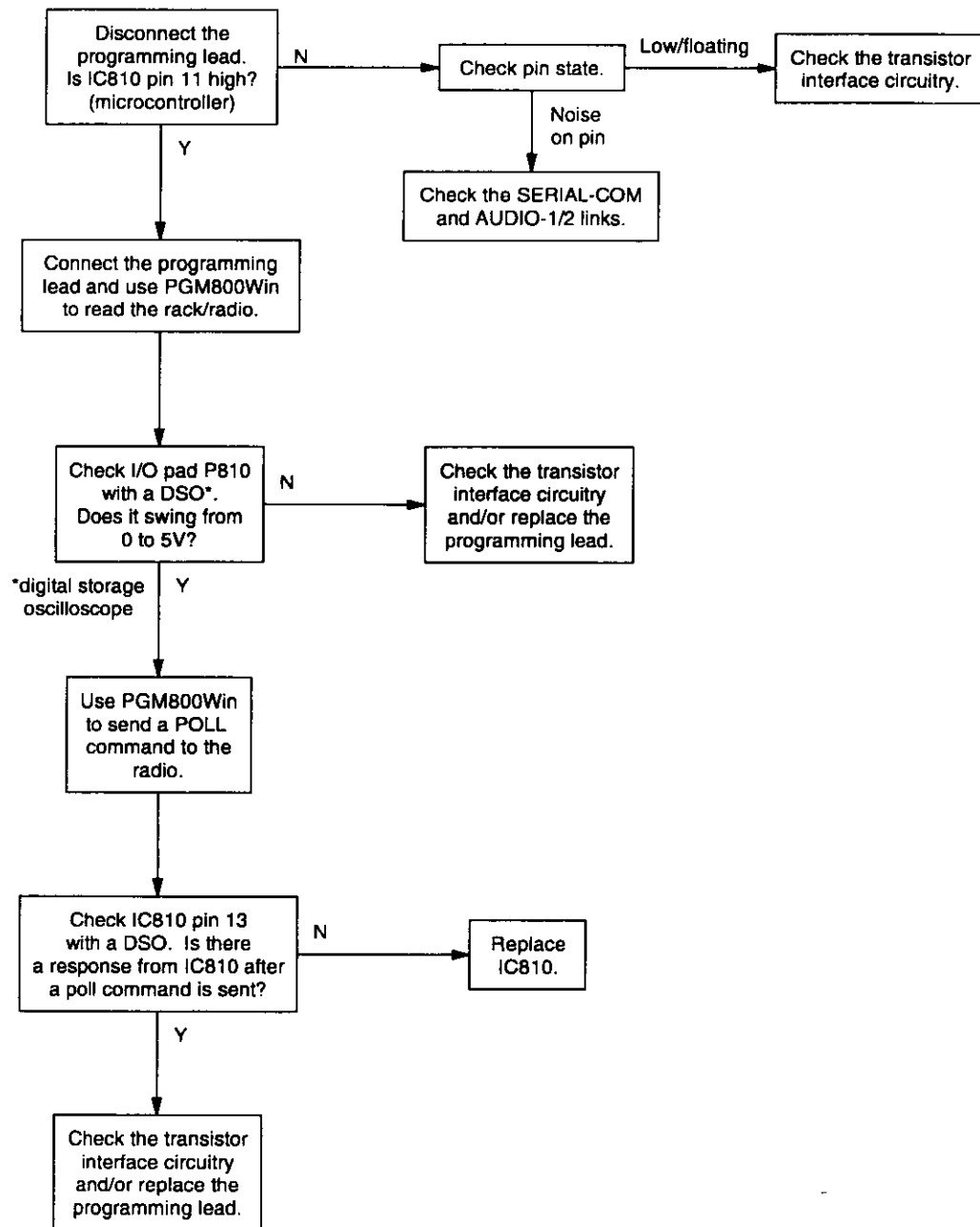

## 5.7.2 Regulator

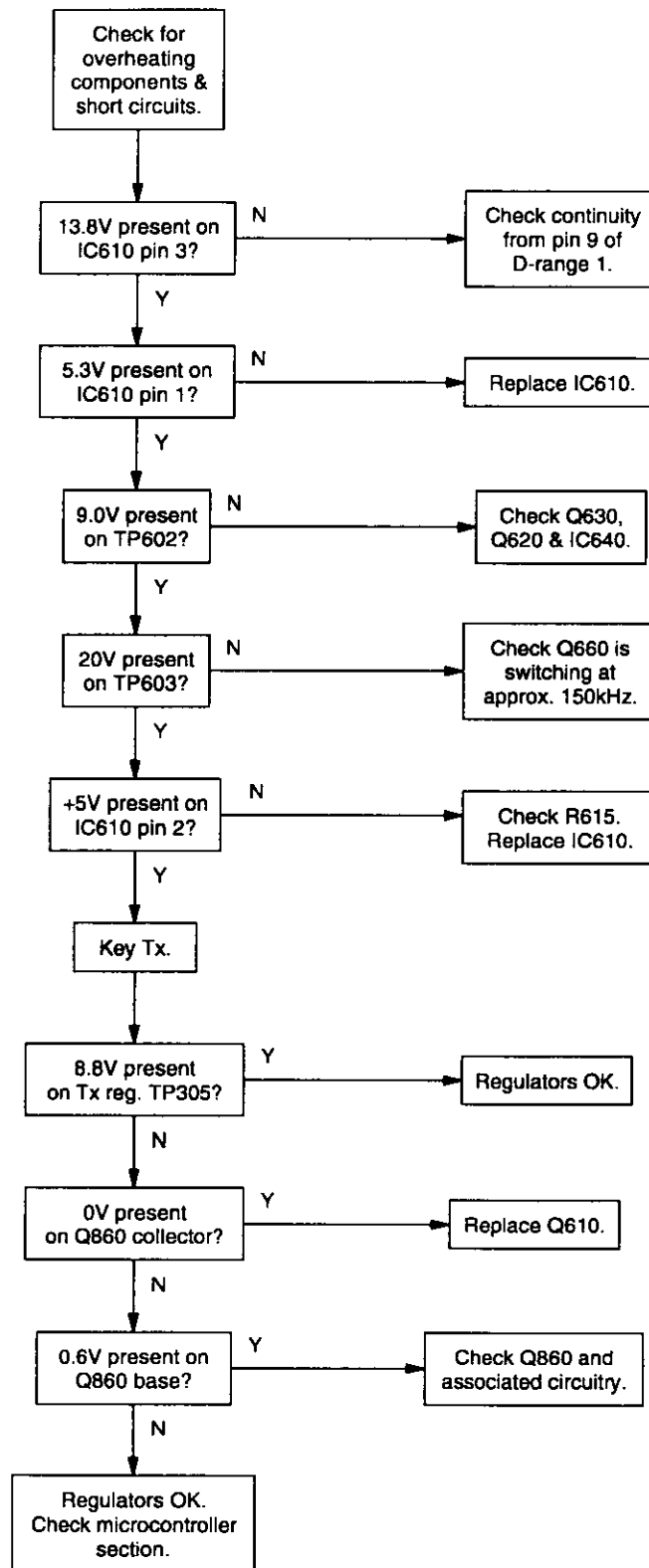

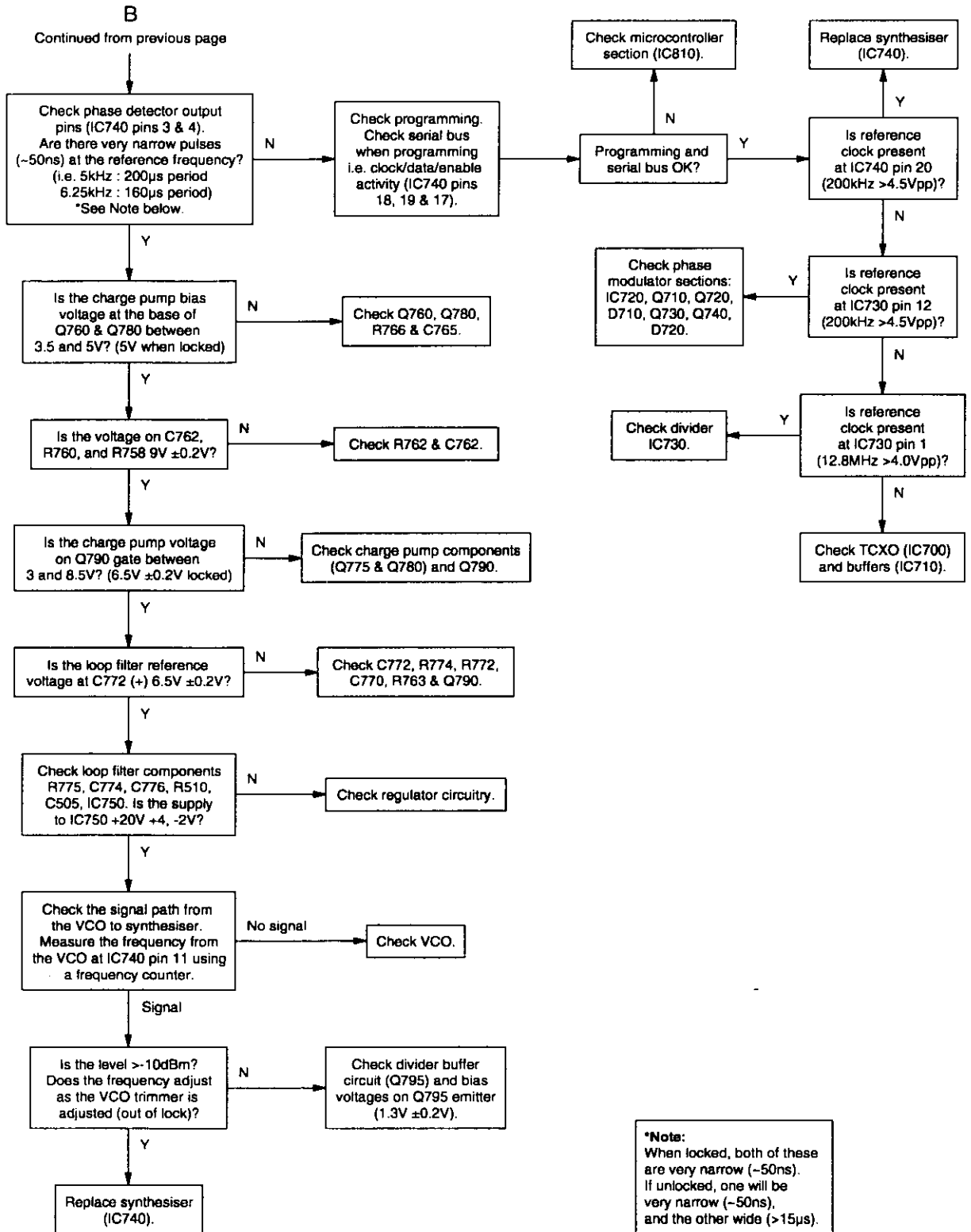

### 5.7.4 T836 Drive Amplifier

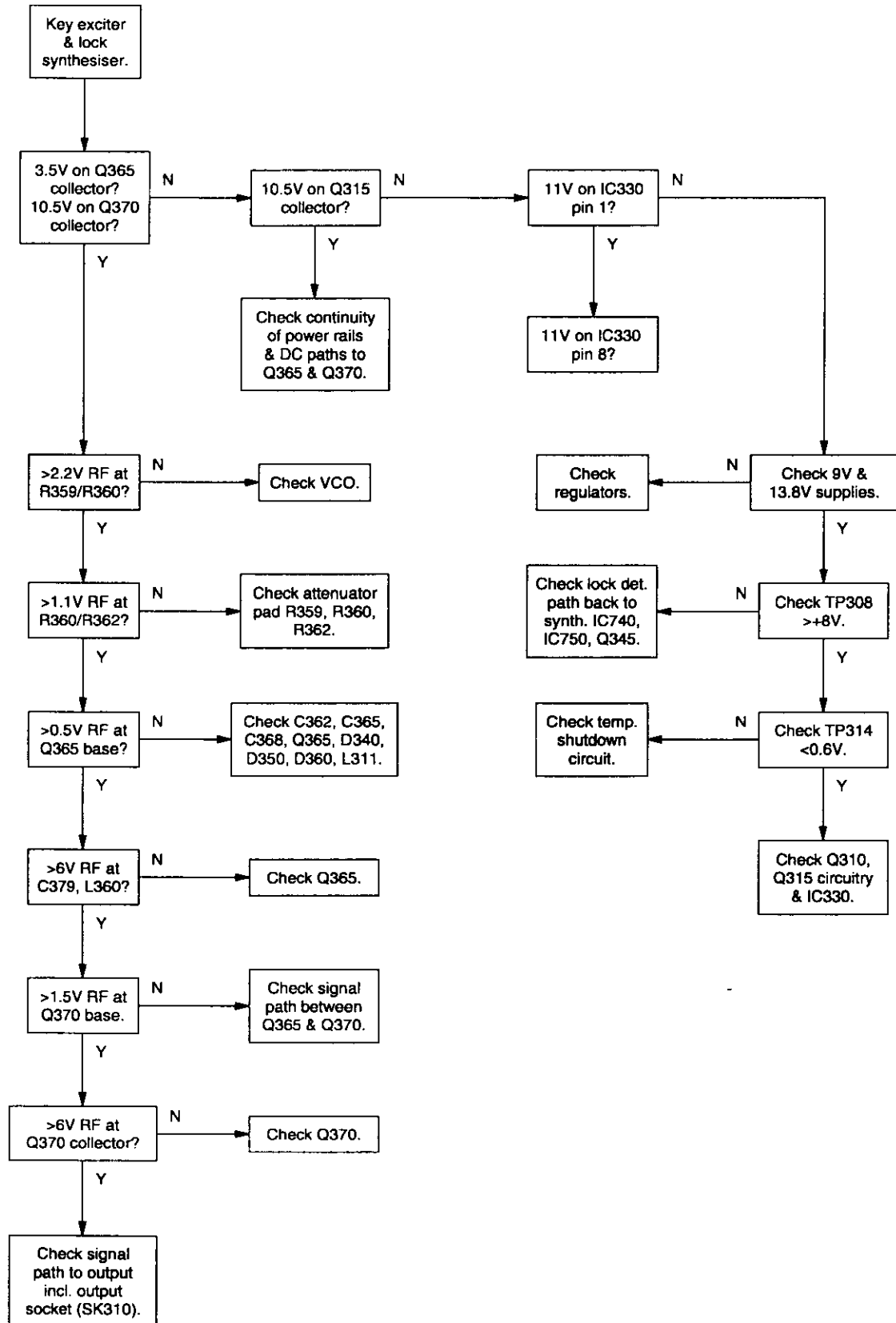



## 5.7.6 T837 Exciter Drive Amplifier

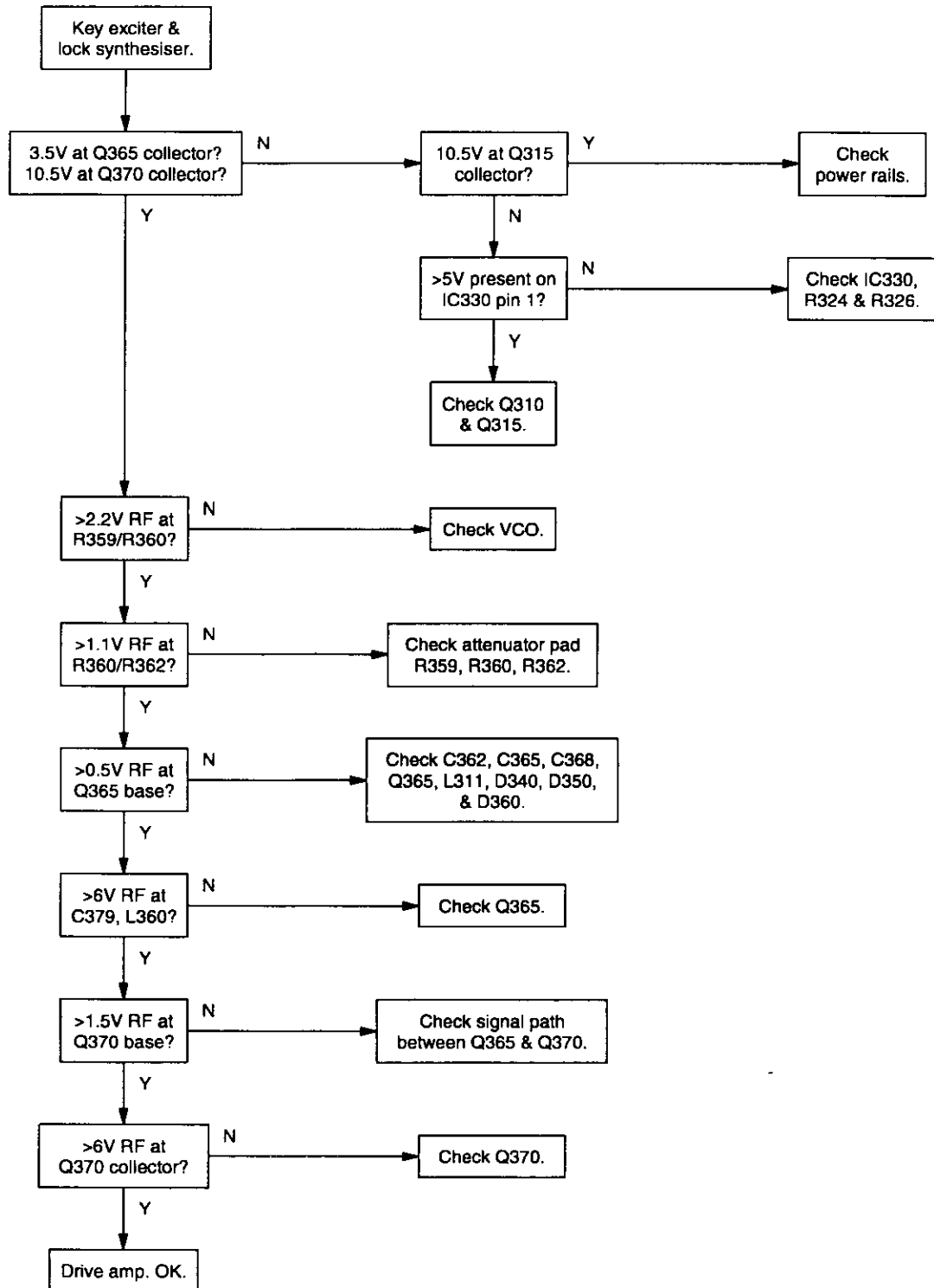

## 5.8 To Replace The T836 PA Transistors (Q415 & Q425)



**Caution:** Failure to comply with the following procedure can result in failure of the device due to poor heatsinking, or worse, can endanger the health of the assembler if the beryllium oxide die carrier is smashed during assembly.



**Caution:** As the location of certain components in the PA is critical to performance, it is important that any components removed or disturbed are refitted in *exactly* the same position.



**Caution:** Before attempting to remove a transistor, note the position, type and value of each capacitor and resistor so that it can be replaced in *exactly* the same position (refer to Figure 5.2).



**Caution:** Do not apply too much heat or pressure to the PCB pads and tracks as you may damage them or lift them from the PCB, causing permanent damage to the transmitter.

Remove the resistors and/or chip capacitors from around the transistor.

Desolder the transistor tabs by heating with a soldering iron and lifting away from the PCB with a screwdriver or thin stainless steel spike. Unscrew the transistor stud nut and remove the device.

Remove any excess solder from the PCB pads with solder wick.

Trim the tabs of the replacement transistor so that the device sits neatly on the PCB pads provided.

Lightly tin the underside of the transistor tabs.

Apply a small amount of heatsink compound (Dow-Corning 340 or equivalent) to the transistor mounting surface. Sufficient compound should be used to ensure an even film over the entire mounting surface.

Place the transistor on the PCB in the correct orientation and ensure the tabs are flush to the surface. Lightly solder one tab to the PCB. Torque down the retaining nut to the correct torque (0.7Nm/6lb-in.).



**Caution:** Do not solder all the tabs before torquing down otherwise the device may be broken.

Solder all transistor tabs to the PCB.

## 6 T836/837 PCB Information

This section provides the following information on the T836 transmitter and T837 exciter:

- parts lists
- grid reference indexes
- mechanical assembly drawings
- PCB layouts
- test points & options connections drawings
- circuit diagrams.

Section	Title	IPN	Page
6.1	Introduction		6.1.3
6.2	T836 Transmitter PCB	220-01395-02	6.2.1
6.3	T837 Exciter PCB	220-01390-02	6.3.1

## 6.1 Introduction

### Product Type Identification

You can identify the transmitter or exciter type by checking the product code printed on a label on the rear of the chassis (product codes are explained in Section 1.3 in this Part of the manual, and Figure 1.1 in Part A shows typical labels). You can further verify the product type by checking the placement of an SMD resistor in the table that is screen printed onto the top side of the PCB, similar to the example drawn below (this table also appears in the resist layer on the bottom side of the PCB). In this example, the resistor indicates that the product was built as a T836-10-XXXX.

■ ■ 836-	PRODUCT TYPE	
■ ■ 836-	■ ■ 836-10	■ ■ 836-20
■ ■ 836-	■ ■ 836-13	■ ■ 836-23
PRODUCT TYPE	■ ■ 836-15	■ ■ 836-25

**Note:** The only function of this resistor is to indicate the product type. It has no effect on the circuitry or operation of the transmitter or exciter.

### PCB Identification

All PCBs are identified by a unique 10 digit "internal part number" (IPN), e.g. 220-12345-00, which is screen printed onto the PCB (usually on the top side), as shown in the example below:

220-01390-02

The last 2 digits of this number define the issue status, which starts at 00 and increments through 01, 02, 03, etc. as the PCB is updated. Some issue PCBs never reach full production status and are therefore not included in this manual. A letter following the 10 digit IPN has no relevance in identifying the PCB for service purposes.

**Note:** It is important that you identify which issue PCB you are working on so that you can refer to the appropriate set of PCB information.

## Variant Components

A variant component is one that has the same circuit reference but different value or specification in different product types. Where two products share the same PCB, the term "variant" is also used to describe components unplaced in one product. Variant components have a character prefix, such as "&", "=", "#", "%", or "\*", before the circuit reference (e.g. &R100).

The table below explains the variant prefixes used in T800 Series II products:

If the variant prefix is . . .	the component will. . .
&	change according to channel spacing
=	change according to frequency stability
#	change according to frequency range
%	be placed or unplaced for special applications
*	be unplaced in one product (where two products share the same PCB)

## Grid Reference Index

This section contains a component grid reference index to help you find components and labelled pads on the PCB layouts and circuit diagrams. This index lists the components and pads in alphanumeric order, along with the appropriate alphanumeric grid references, as shown below:

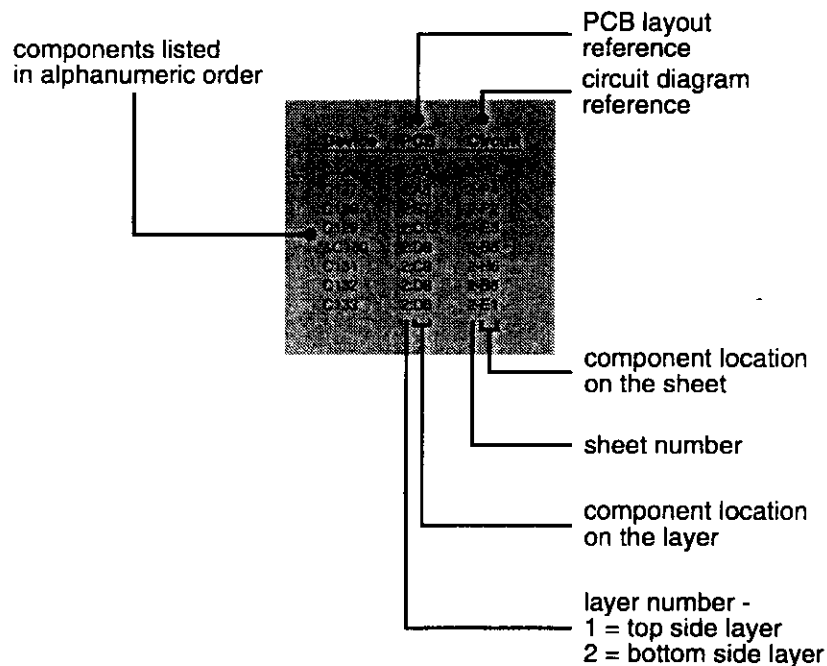

## 6.3 T837 Exciter PCB

This section contains the following information.

IPN	Section	Page
220-011390-02	Parts List	6.3.3
	Mechanical & Miscellaneous Parts	6.3.8
	Mechanical Assembly	6.3.9
	Grid Reference Index	6.3.11
	PCB Layout - Top Side	6.3.15
	PCB Layout - Bottom Side	6.3.16
	Test Points & Options Connections - Top & Bottom Side	6.3.17
	Exciter Overview Diagram	6.3.18
	Audio Processor Circuit Diagram	6.3.19
	Exciter Circuit Diagram	6.3.20
	VCO Section Circuit Diagram	6.3.22
	Regulators Circuit Diagram	6.3.23
	Synthesiser Circuit Diagram	6.3.24
	Microcontroller Circuit Diagram	6.3.25
Harmonic Filter Circuit Diagram	6.3.26	

## T837 Parts List (IPN 220-01390-02)

### How To Use This Parts List

The components listed in this parts list are divided into two main types: those with a circuit reference (e.g. C2, D1, R121, etc.) and those without (miscellaneous and mechanical).

Those with a circuit reference are grouped in alphabetical order and then in numerical order within each group. Each component entry comprises three or four columns: the circuit reference, variant (if applicable), IPN and description. A number in the variant column indicates that this is a variant component which is fitted only to the product type listed. Static sensitive devices are indicated by an (S) at the start of the description column.

The mechanical and miscellaneous section lists the variant and common parts in IPN order. Where possible, a number in the legend column indicates their position in the mechanical assembly drawing.

The Parts List Amendments box below lists component changes that took place after the parts list and diagrams in this section were compiled. These changes (e.g. value changes, added/deleted components, etc.) are listed by circuit reference in alphanumeric order and supersede the information given in the parts list or diagrams. Components without circuit references are listed in IPN order.

### Parts List Amendments

IC710	Changed from 74HCV04 to 74HC04 (IPN 002-74900-04) to increase the gain of the TCXO buffer (710312).	
L360	Changed from 3.5T/4.0mm (052-08140-35) to 3.5T/3.5mm (052-08135-35)	
L365	Changed from 1.5T/3.0 (IPN 052-08130-15) to 1.5T/3.5 (IPN 052-08135-15) to improve power output evenly at the top and bottom of the 136-174MHz frequency range (710333).	
L385	136-156MHz (-10, -13 & -15): changed from 3.5T/4.0 (052-08140-35) to 3.5T/4.5 (IPN 052-08145-35) to improve the output power (710332).	
R221, R239	Changed from 680 $\Omega$ (036-13680-00) to 1k5 (036-14150-00)	} To improve power at 174MHz (710028).
R235, R545	Changed from 2k2 (036-14220-00) to 4k7 (036-14470-00)	
R290	Changed from 560 $\Omega$ (036-13560-00) to 680 $\Omega$ (036-13680-00) to reduce the level of side bands generated (710028).	
R304	Changed from 15k (036-15150-00) to 2k7 (036-14270-00)	} To improve power at 174MHz (710028).
R332	Changed from 22k (036-15220-00) to 47k (036-15470-00)	
R364, R372	Changed from 1k0 (036-14100-00) to 1k5 (036-14150-00)	
R368	Changed from 1k0 (036-14100-00) to 10k (036-15100-00)	
R677	Changed from 1k0 (036-14100-00) to 47k (036-15470-00)	





Ref	Var	IPN	Description	Ref	Var	IPN	Description
R842		036-14220-00	RES M/F 0805 2K2 5%				
R843		036-14220-00	RES M/F 0805 2K2 5%				
R845		036-13470-00	RES M/F 0805 470E 5%				
R846		036-13470-00	RES M/F 0805 470E 5%				
R847		036-13470-00	RES M/F 0805 470E 5%				
R848		036-14470-00	RES M/F 0805 4K7 5%				
R849		036-13470-00	RES M/F 0805 470E 5%				
R850		036-13470-00	RES M/F 0805 470E 5%				
R853		036-14470-00	RES M/F 0805 4K7 5%				
R854		036-14470-00	RES M/F 0805 4K7 5%				
R855		036-14470-00	RES M/F 0805 4K7 5%				
R859		036-18150-00	RES M/F 0805 150K 5%				
R861		036-16150-00	RES M/F 0805 150K 5%				
R863		036-16150-00	RES M/F 0805 150K 5%				
R865		036-16100-00	RES M/F 0805 100K 5%				
R867		036-16100-00	RES M/F 0805 100K 5%				
R871		036-15470-00	RES M/F 0805 47K 5%				
R872		036-14470-00	RES M/F 0805 4K7 5%				
R873		036-15330-00	RES M/F 0805 33K 5%				
R874		036-14470-00	RES M/F 0805 4K7 5%				
R875		036-15470-00	RES M/F 0805 47K 5%				
R876		036-14470-00	RES M/F 0805 4K7 5%				
R877		036-14470-00	RES M/F 0805 4K7 5%				
R879		036-15100-00	RES M/F 0805 10K 5%				
RV210		040-05100-23	POT 10K LOG PCB 15MM SLOT SFT				
RV220		042-05470-06	RES PRE 47K CAR 6MM FLAT T/ADJ				
RV805		042-05220-07	RES PRE 22K CAR 6MM FLAT D/ADJ				
SK205		240-02020-05	SKT STEREO PHONE JACK PCB MTG				
SK310		240-02100-44	SKT COAX MINI JACK PCB MT ANG.				
SK420		240-02100-44	SKT COAX MINI JACK PCB MT ANG.				
SK501		240-04021-77	SKT JACK 1.3 PCB MT 64W				
SK502		240-04021-77	SKT JACK 1.3 PCB MT 64W				
SK503		240-04021-77	SKT JACK 1.3 PCB MT 64W				
SK504		240-04021-77	SKT JACK 1.3 PCB MT 64W				
SK505		240-04021-77	SKT JACK 1.3 PCB MT 64W				
SK513		240-04021-77	SKT JACK 1.3 PCB MT 64W				
SK522		240-04021-77	SKT JACK 1.3 PCB MT 64W				
SK531		240-04021-77	SKT JACK 1.3 PCB MT 64W				
SK532		240-04021-77	SKT JACK 1.3 PCB MT 64W				
SK533		240-04021-77	SKT JACK 1.3 PCB MT 64W				
SK534		240-04021-77	SKT JACK 1.3 PCB MT 64W				
SK535		240-04021-77	SKT JACK 1.3 PCB MT 64W				
SK805		240-10000-07	CONN SMD SKT 16W 2R M-MATCH				
SK810		240-04020-42	SKT 44 PIN SMD PLCC				
SW230		232-00010-26	SWITCH PUSH SPDT R-ANG PCB MTG				
T210		053-00010-17	XFMR T4030 LINE MATCH POTCORE				
T610		050-00016-50	COIL TAIT NO 650 455KHZ				

### T839 Grid Reference Index

Device	PCB	Circuit	Device	PCB	Circuit	Device	PCB	Circuit	Device	PCB	Circuit
*C101	1:E4	1-B8	C220	1:E5	2-D9	*L231	1:L4	2-J4	R141	1:E3	1-B5
*C103	1:E4	1-B9	C221	1:E5	2-Q9	L233	1:F6	2-R6	R142	1:E3	1-E7
*C105	1:B3	1-D8	C222	1:E5	2-E9	*L236	1:H6	2-N3	R143	1:E4	1-F6
*C107	1:B3	1-D9	C223	1:D5	2-H9	L239	1:E5	2-R3	R144	1:D3	1-F6
*C109	1:B3	1-D8	C224	1:D5	2-N9	L241	1:D6	2-R4	R145	1:E4	1-F7
*C111	1:C4	1-D8	C225	1:L6	2-J7	L243	1:C6	2-R4	R146	1:E4	1-G7
*C113	1:B5	1-F8	C226	1:D4	2-H9	L245	1:C7	2-R4	R148	1:C5	1-D5
*C115	1:B5	1-F8	C227	1:K6	2-K7	L247	1:C6	2-R4	R149	1:C5	1-C4
*C117	1:B5	1-F9	C229	1:H6	2-L6	L248	1:D7	2-R4	R150	1:C4	1-F0
*C119	1:B5	1-G8	*C230	1:L4	2-J4	L249	1:B6	2-R4	R151	1:B5	1-D5
*C121	1:D4	1-B6	*C231	1:L4	2-J3	L264	1:C6	2-M9	R152	1:B5	1-C3
*C123	1:D4	1-B6	*C232	1:K4	2-K3	LINK1	1:D3	1-L0	R153	1:C5	1-F4
*C125	1:C4	1-D7	*C233	1:K4	2-M3	LINK2	1:P6	1-D1	R154	1:C5	1-F3
*C127	1:C4	1-D6	*C234	1:J4	2-N3	LINK201	1:D5	2-F9	R155	1:D3	1-F2
C129	1:B3	1-H5	*C240	1:H4	2-L2	P101	1:A5	1-R9	R156	1:D3	1-F3
C131	1:B3	1-J6	C259	1:F7	2-R5	P103	1:K3	1-R0	R157	1:D4	1-G0
C132	1:A3	1-K7	C261	1:F6	2-R6	P105	1:K2	1-R0	R158	1:C4	1-H3
C133	1:B4	1-K8	C268	1:E6	2-R4	P201	1:B6	2-R4	R159	1:C4	1-H4
C137	1:B2	1-K8	C270	1:D6	2-R4	PL101	1:L3	1-C2	R160	1:C3	1-J5
C138	1:B2	1-L8	C271	1:C6	2-R4	*Q101	1:C3	1-C9	R161	1:B3	1-J3
C139	1:B4	1-M6	C272	1:B6	2-R4	*Q103	1:B3	1-E8	R162	1:B3	1-K4
C141	1:B3	1-M8	C273	1:B6	2-R4	*Q105	1:C4	1-D7	R163	1:P7	1-K5
C143	1:E3	1-E7	C294	1:D6	2-R3	*Q107	1:B5	1-F8	R164	1:B3	1-K4
C145	1:E3	1-F7	C295	1:D6	2-R3	*Q109	1:A5	1-G9	R165	1:B4	1-K4
C147	1:D3	1-F6	C297	1:C5	2-M9	Q111	1:A3	1-J7	R166	1:P6	1-L5
C149	1:D3	1-F7	C298	1:C6	2-M9	Q113	1:A3	1-K6	R168	1:E4	1-A1
C151	1:C5	1-D5	D101	1:B3	1-H5	Q115	1:A3	1-L7	R169	1:E4	1-A0
C153	1:B5	1-D3	D101	1:B3	1-G5	Q117	1:B4	1-K8	R170	1:D4	1-B0
C155	1:D3	1-G3	D103	1:P7	1-K9	Q119	1:B4	1-L6	R171	1:E4	1-B0
C159	1:B3	1-H2	D105	1:C2	1-J2	Q121	1:B3	1-L8	R172	1:E4	1-B0
C161	1:B4	1-K4	D105	1:C2	1-J2	Q123	1:E3	1-E7	R173	1:P6	1-C1
C162	1:B3	1-L4	D107	1:P7	1-K5	Q125	1:E3	1-F7	R174	1:P6	1-C1
C164	1:B3	1-L4	D109	1:P6	1-L5	Q127	1:D3	1-G7	R175	1:D4	1-C0
C165	1:B3	1-M4	D111	1:C2	1-M1	Q129	1:B4	1-L4	R176	1:D4	1-D0
C167	1:K3	1-P3	D111	1:C2	1-M1	Q131	1:B3	1-M5	R177	1:D4	1-D0
C169	1:K3	1-P3	D113	1:F7	1-Q2	Q133	1:D4	1-D0	R178	1:D3	1-E1
C171	1:K3	1-Q3	D201	1:F6	2-R5	Q135	1:E2	1-H0	R179	1:D4	1-E0
C173	1:D4	1-B0	D202	1:D4	2-J9	Q136	1:E3	1-H0	R180	1:D4	1-E0
C174	1:E4	1-B0	D202	1:D4	2-J9	Q137	1:D2	1-J0	R181	1:E3	1-F2
C176	1:D4	1-E0	D203	1:E6	2-R4	Q201	1:D5	2-L9	R182	1:D4	1-E0
C178	1:C4	1-F0	IC101	1:D4	1-C6	R101	1:E4	1-A8	R183	1:D4	1-F1
C179	1:D3	1-G2	IC101	1:D4	1-G0	*R102	1:E4	1-A9	R184	1:E3	1-G1
C180	1:E2	1-H0	IC101	1:D4	1-B8	R103	1:E4	1-A8	R185	1:E2	1-J0
C181	1:D3	1-G0	IC101	1:D4	1-C0	R104	1:E4	1-B9	R186	1:D2	1-H1
C182	1:D3	1-H1	IC101	1:D4	1-N0	*R105	1:D4	1-C8	R187	1:E2	1-H0
C184	1:D4	1-G0	IC103	1:C4	1-D4	*R106	1:B3	1-C8	R188	1:D2	1-L1
C185	1:D2	1-J1	IC103	1:C4	1-J8	*R107	1:C4	1-D7	R189	1:D2	1-L1
C186	1:E2	1-J0	IC103	1:C4	1-F0	*R108	1:B3	1-E9	R190	1:C3	1-M1
C187	1:D3	1-K1	IC103	1:C4	1-J5	*R109	1:C3	1-E9	R191	1:B2	1-P1
C188	1:C2	1-L1	IC103	1:C4	1-E3	*R111	1:B5	1-E8	R192	1:B2	1-P1
C189	1:C3	1-M1	IC105	1:D3	1-M0	*R112	1:B5	1-E9	R193	1:C2	1-Q1
C190	1:C3	1-N1	IC105	1:D3	1-P0	*R113	1:B5	1-F9	R194	1:D2	1-H0
C192	1:B2	1-N1	IC105	1:D3	1-G2	*R114	1:C4	1-A6	R195	1:D3	1-J0
C193	1:B2	1-P1	IC107	1:D3	1-K1	*R115	1:C5	1-A6	R196	1:D3	1-J0
C195	1:C2	1-Q1	IC109	1:B2	1-N1	*R116	1:D4	1-A7	R197	1:D3	1-L1
C201	1:J7	2-N7	*IC201	1:K6	2-J7	R117	1:C4	1-A6	*R201	1:N6	2-D2
*C202	1:H3	2-B9	*IC202	1:K4	2-J2	R118	1:D4	1-B6	*R202	1:N6	2-D2
*C203	1:P7	2-D3	*IC203	1:N5	2-F4	R119	1:D4	1-C7	R203	1:L7	2-J8
*C204	1:M6	2-E2	IC204	1:D5	2-H9	*R121	1:C4	1-C7	*R204	1:N6	2-E2
C205	1:L7	2-J8	IC204	1:D5	2-P9	*R122	1:C4	1-D6	R205	1:K7	2-M7
*C206	1:P6	2-D2	IC204	1:D5	2-H9	R123	1:B4	1-H7	*R206	1:C5	2-E9
C207	1:K7	2-M7	*IC205	1:G5	2-R4	R124	1:B4	1-H8	R207	1:C5	2-G9
*C208	1:H2	2-C9	L101	1:K3	1-P3	R125	1:B4	1-H8	*R208	1:C5	2-G9
*C209	1:C5	2-D9	L103	1:K2	1-Q3	R126	1:B3	1-H6	R209	1:D5	2-G9
*C210	1:C5	2-E9	L105	1:E2	1-K0	R127	1:A3	1-H7	R210	1:D5	2-G9
*C212	1:D5	2-H9	*L201	1:P7	2-C3	R128	1:A3	1-J7	*R211	1:D4	2-H9
*C213	1:D4	2-H9	*L202	1:H3	2-C9	R129	1:B4	1-J9	R212	1:D4	2-J9
C215	1:D5	2-K9	L203	1:L7	2-J9	R130	1:B4	1-J8	R213	1:D5	2-F9
C216	1:H5	2-B9	*L204	1:C5	2-D9	R131	1:A3	1-J7	R214	1:E4	2-K9
*C217	1:P3	2-E4	L206	1:H5	2-C9	R132	1:B5	1-J8	*R215	1:H3	2-B9
C218	1:H5	2-C9	L208	1:E5	2-D9	R133	1:A3	1-K7	*R216	1:P6	2-E4
*C219	1:P2	2-E5	*L211	1:P2	2-D5	R134	1:B3	1-K6	*R217	1:P6	2-E4
			L215	1:L7	2-J8	R135	1:P7	1-K9	R218	1:E5	2-E9
			L217	1:J7	2-L8	R136	1:A3	1-K7	R219	1:H6	2-B9
			*L223	1:J4	2-L3	R137	1:B3	1-K6	R220	1:E5	2-G9
			*L230	1:L4	2-J5	R138	1:B4	1-L6	R222	1:D5	2-G9





## T837 Mechanical &amp; Miscellaneous Parts (220-01390-02)

IPN	Legend	Description	IPN	Legend	Description
012-04150-01		CAP CER F/THRU 1N5 NO LEAD Fitted to D-range pins.	365-00100-09		LABEL WHITE VINYL 15X11MM S/A
051-00006-02		SOLDER SPRING 1.3MM A4M1877 Support for front panel LED solder joints.	365-00100-20		LABEL WHITE S/A 28X11MM
065-00010-13		BEAD FER 7D 1.9X0.9X3.8 Fitted to D-range pins.	365-01541-00		LABEL TX/RX/EX TYPE APR/SER NO
200-00010-05		WIRE T/C 0.5 For ferrite beads.	400-00020-07		SLEEVING 2MM SIL RUBBER
201-00030-02		WIRE T/C 7/0.2 PVC RED Front panel LEDs.	410-01081-01		CRT T800 SERIES II
201-00030-10		WIRE T/C 7/0.2 PVC BLACK Front panel LEDs.	410-01082-01		CRTN 10 T800 KIWI 423X410X360
206-00010-11		COAX 50 OHM RG316-U PTFE Connects SK310 to SK420.			
220-01176-03	1	PCB T83X VCO			
220-01390-02	2	PCB T837 EX SERIES II			
232-00020-26	3	BUTTON 232-00010-26 SWITCH			
240-00010-55	25	PLUG 15 W D RANGE W/W PNL MT PL100.			
240-00100-43		PLG COAX MINI PIN CRIMP 1.5D For coax connecting SK310 to SK420.			
240-02100-06	4	SKT COAX N TYPE PNL MTG OP-TER			
240-04020-62		SKT 2 W RECEP SHORTING LINK PL205/210/215/220.			
303-11169-03	5	CHASSIS PAINTED T800 SERIES			
303-23118-00	6	COVER A3M2247 D RANGE			
303-50074-00	7	CLIP A3M2246 SPRING CLAMP			
303-50078-00	8	CLIP A4M2630 SPR. CABLE CLAMP			
308-01007-01	9	HANDLE BASE STATION SERIES II			
312-01052-01	10	LID TOP PNTD A1M2364 T800			
312-01053-01	11	LID BOTTOM PNTD A1M2364 T800			
316-06619-00	12	PNL FRT EX NO EX OUT SER II			
319-01152-00	13	SHIELD A3M2250 F/THRU MTG			
345-00040-10	14	SCRW M3X6MM P/POZ ST BZ			
349-00020-36	15	LIM)SCREW TT M3X8m PANTORX BLK			
349-00020-43	16	SCRW T/T M4X12MM P/POZ BZ			
349-00020-45	17	SCRW T/T M4X20MM P/POZ BZ			
350-00016-42	18	SPACER 5MM HI 8MM ST 2.5MM HO			
352-00010-08	19	NUT M3 COLD FORM HEX ST BZ			
352-00010-29	20	NUT M4 NYLOC HEX			
353-00010-10	21	WSHR M3 FLAT 7MMX0.6MM ST BZ			
353-00010-13	22	WSHR M3 S/PROOF INT BZ			
362-00010-08		GASKET SIL INSUL TO-5 TO-39 Under Q370.			
362-00010-23	23	GASKET SIL TO-220 CLIP MTG.			
362-00010-33	24	GROMMET LED MTG 3MM			
365-00011-53		LABEL 104X37MM			









## Using CAD Circuit Diagrams

Reading a CAD circuit diagram is similar to reading a road map, in that both have an alphanumeric border. The circuit diagrams in this manual use letters to represent the horizontal axis, and numbers for the vertical axis. These circuit diagram "grid references" are useful in following a circuit that is spread over two or more sheets.

When a line representing part of the circuitry is discontinued, a reference will be given at the end of the line to indicate where the rest of the circuitry is located, as shown below. The first digit refers to the sheet number and the last two characters refer to the location on that sheet of the continuation of the circuit (e.g. 1R3).

these grid references  
show where the circuit  
is continued

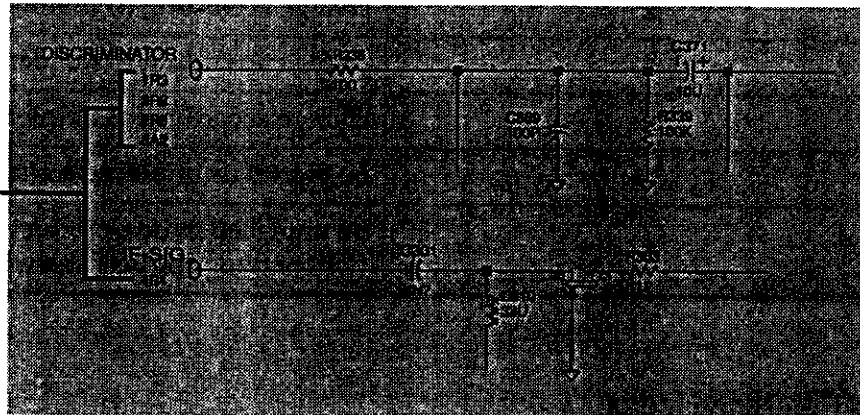

## Parts Lists

The 10 digit numbers (000-00000-00) in this Parts List are "internal part numbers" (IPNs). We can process your spare parts orders more efficiently and accurately if you quote the IPN and provide a brief description of the part.

The components listed in this parts list are divided into two main types: those with a circuit reference (e.g. C2, D1, R121, etc.) and those without (miscellaneous and mechanical).

Those with a circuit reference are grouped in alphabetical order and then in numerical order within each group. Each component entry comprises three or four columns, as shown below:

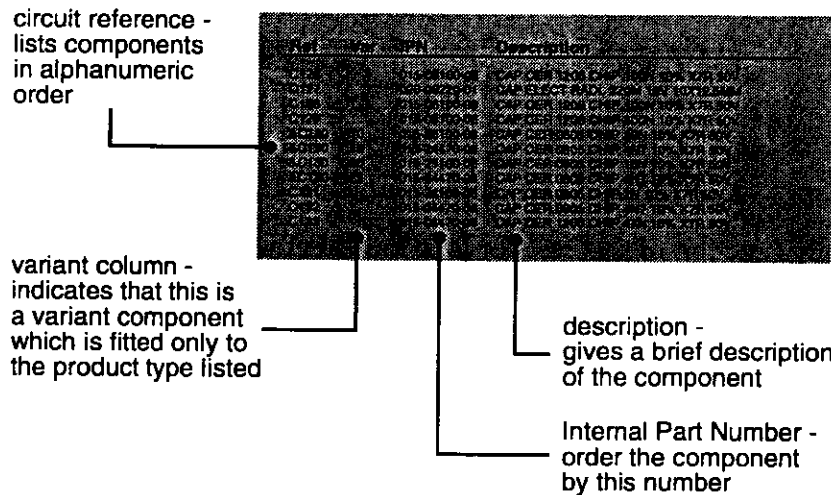

The mechanical and miscellaneous section lists the variant and common parts in IPN order.

## Parts List Amendments

At the front of the parts list is the Parts List Amendments box (an example of which is shown below). This box contains a list of component changes which took place after the parts list and diagrams in this section were compiled. These changes (e.g. value changes, added/deleted components, etc.) are listed by circuit reference in alphanumeric order and supersede the information given in the parts list or diagrams. Components without circuit references are listed in IPN order. The number in brackets at the end of each entry refers to the Tait internal Change Order document.

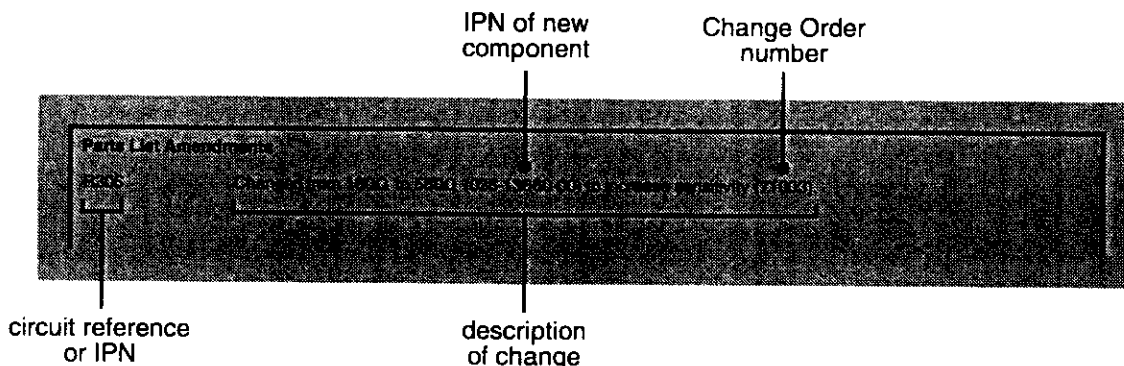



Replace each resistor and/or capacitor in exactly the same position as noted previously.

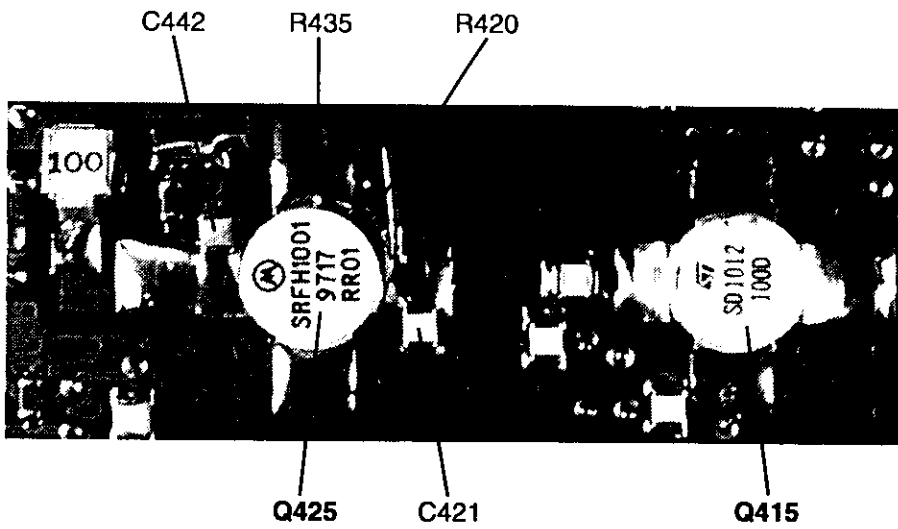
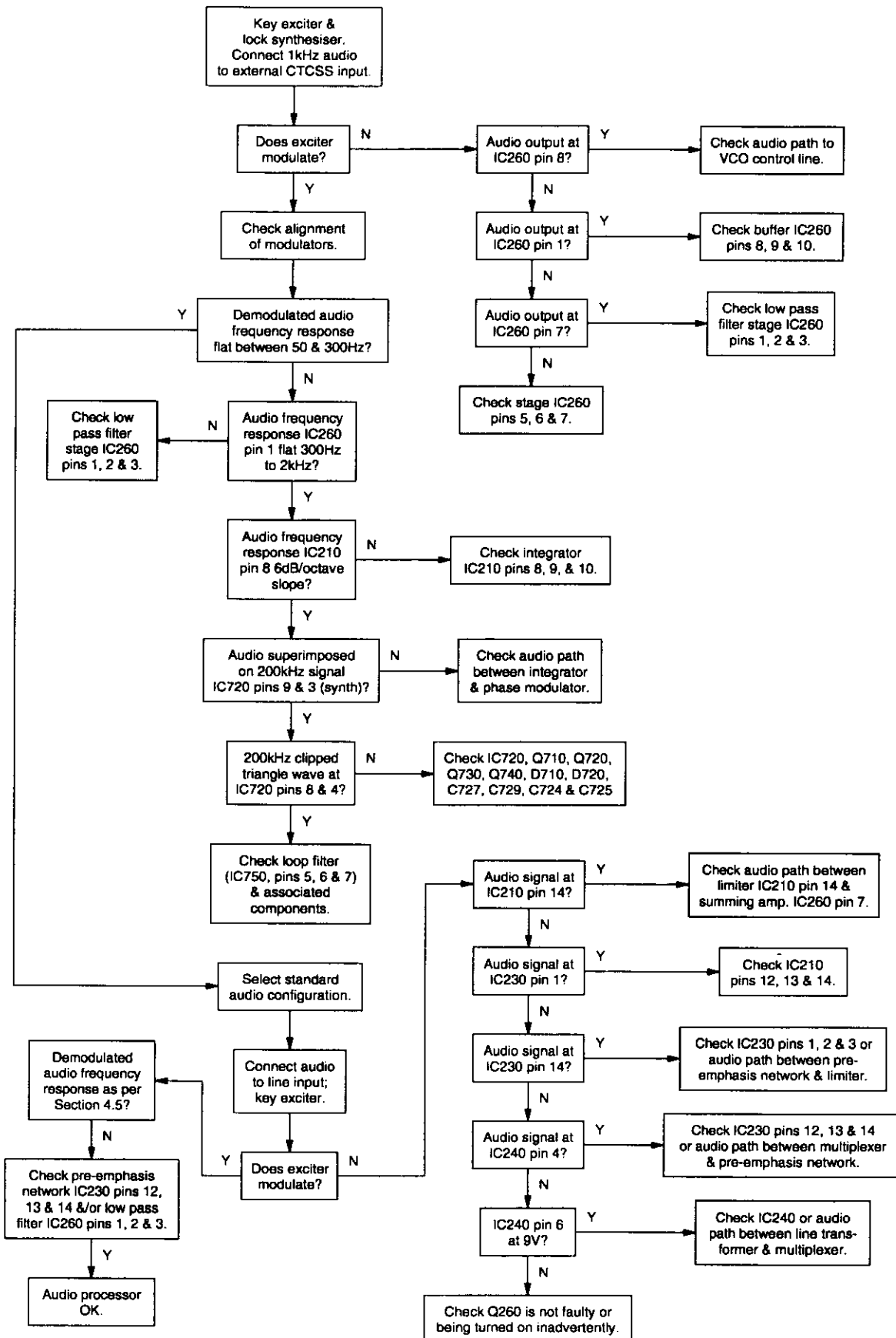

Figure 5.2 Positioning Of Components Around Q425 & Q415

### 5.7.7 Audio Processor



5.7.5 T836 PA & Power Control

Normal operating conditions:

- Forward power = 3.2V approx.
- Reverse power = 0.3V approx.
- IC350a pin 2 = 2V
- IC350a pin 3 = 3.8V
- IC350a pin 1 = 11V

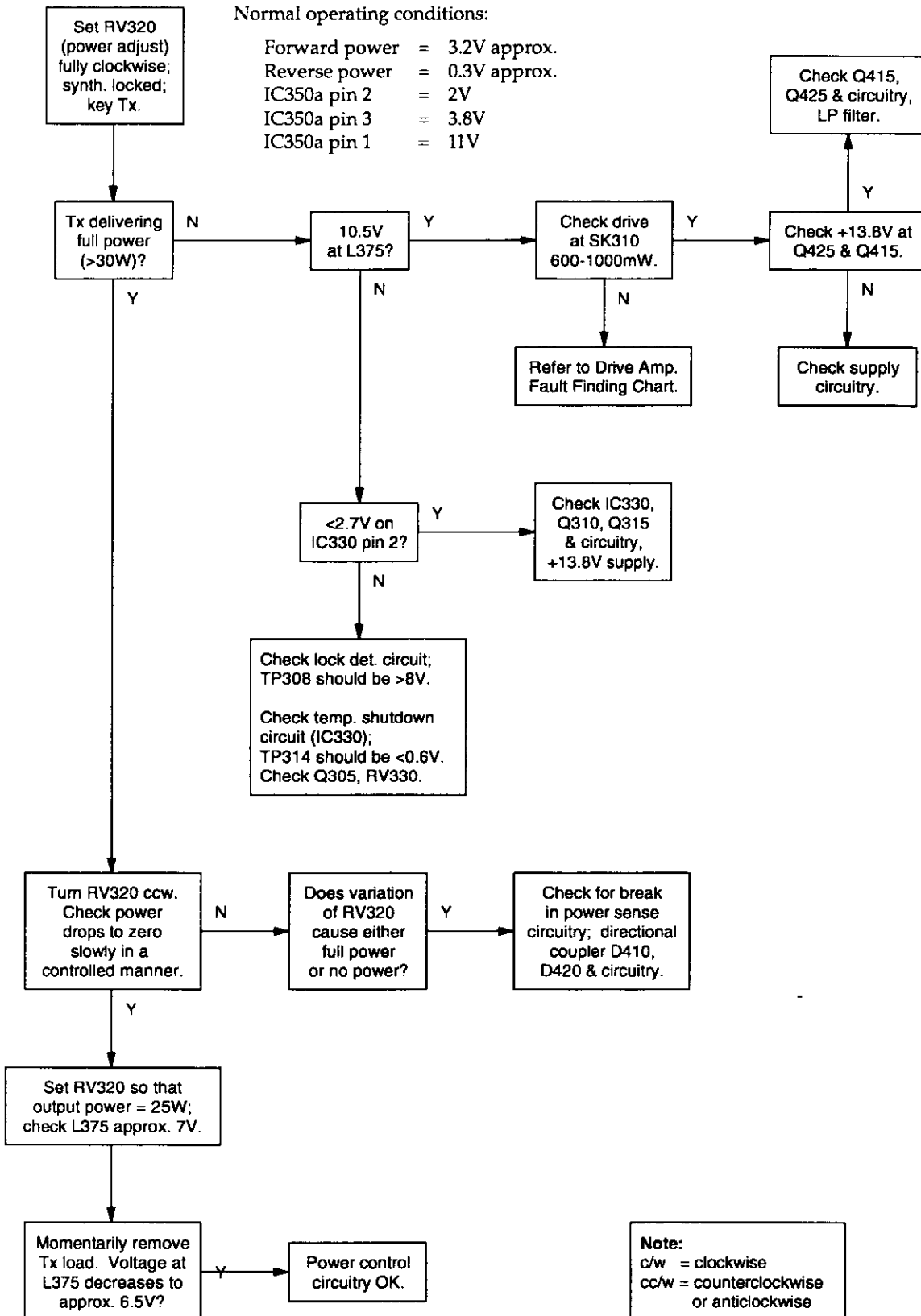

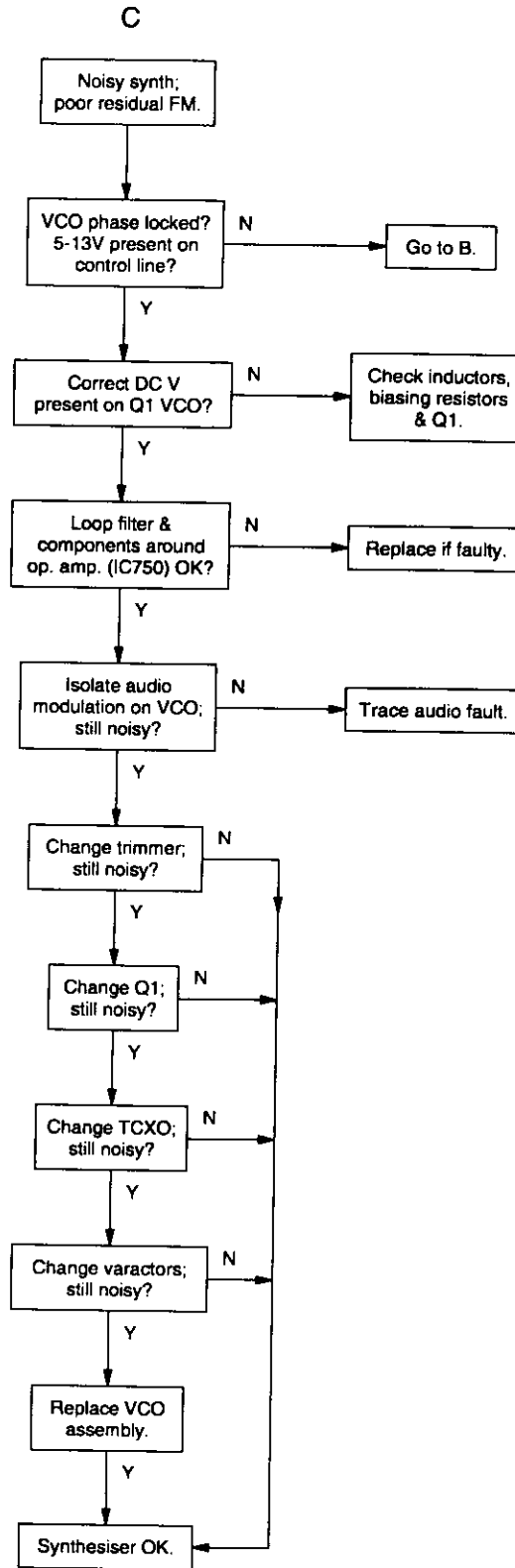

### 5.7.3 Synthesiser

Refer to the synthesiser circuit diagram (sheet 7) in Section 6 and the VCO circuit diagram in Part E.

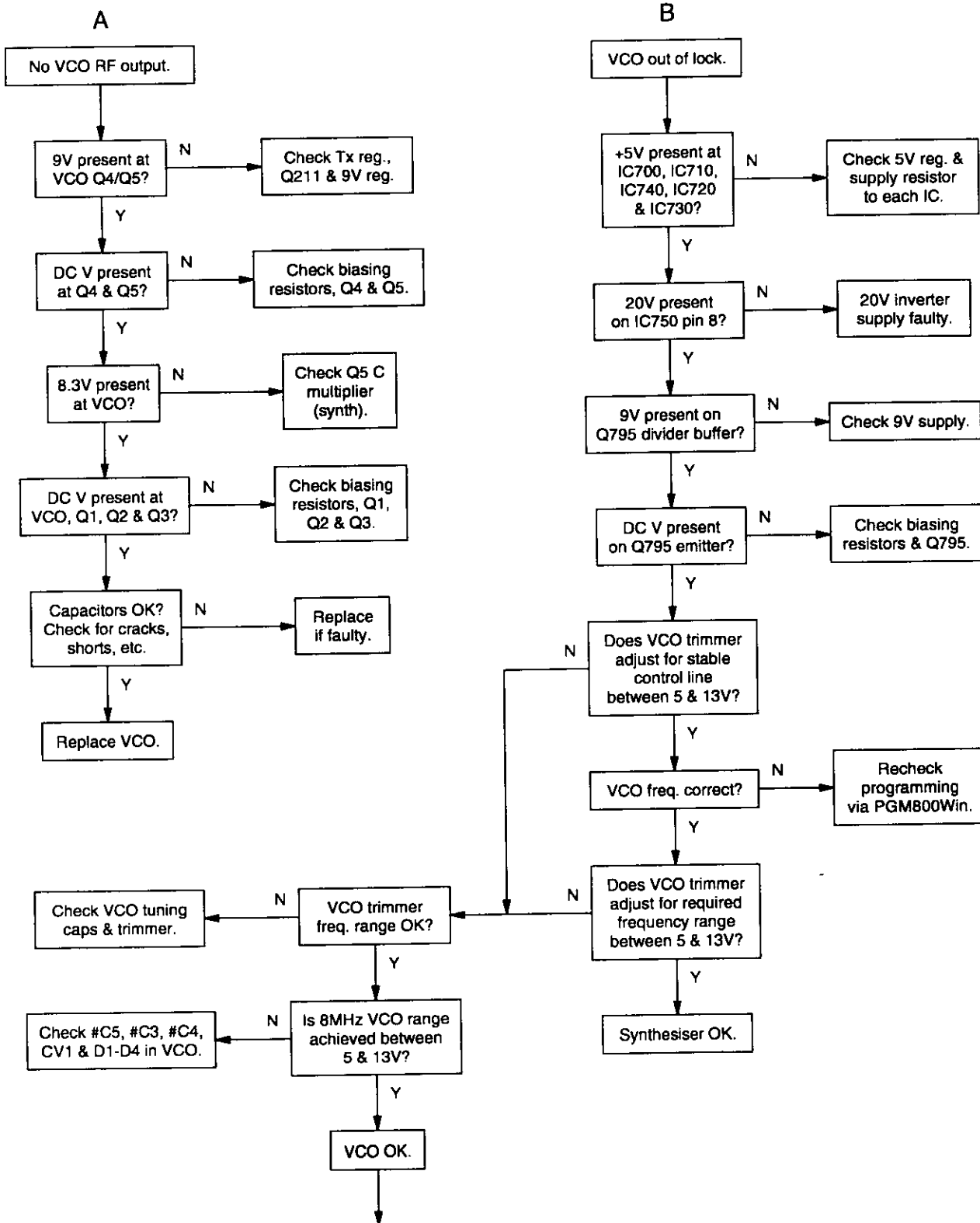

Continued on the next page



5.7.1.3 CTCSS Encode

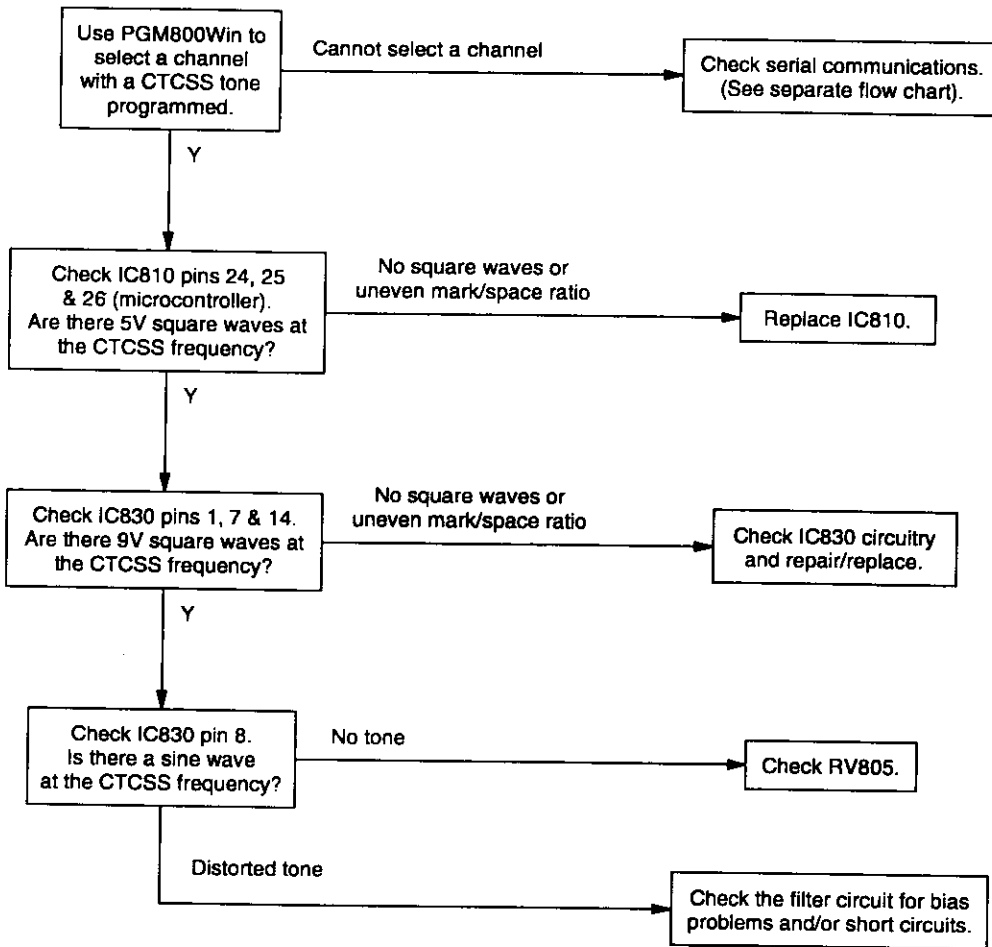

## 5.7 Fault Finding Charts

**Note:** The standard test point designations used in this section are as follows:

TP601	13.8V
TP602	9V
TP603	20V
TP604	5V

### 5.7.1 Microcontroller (IC810)

#### 5.7.1.1 Basic Checks

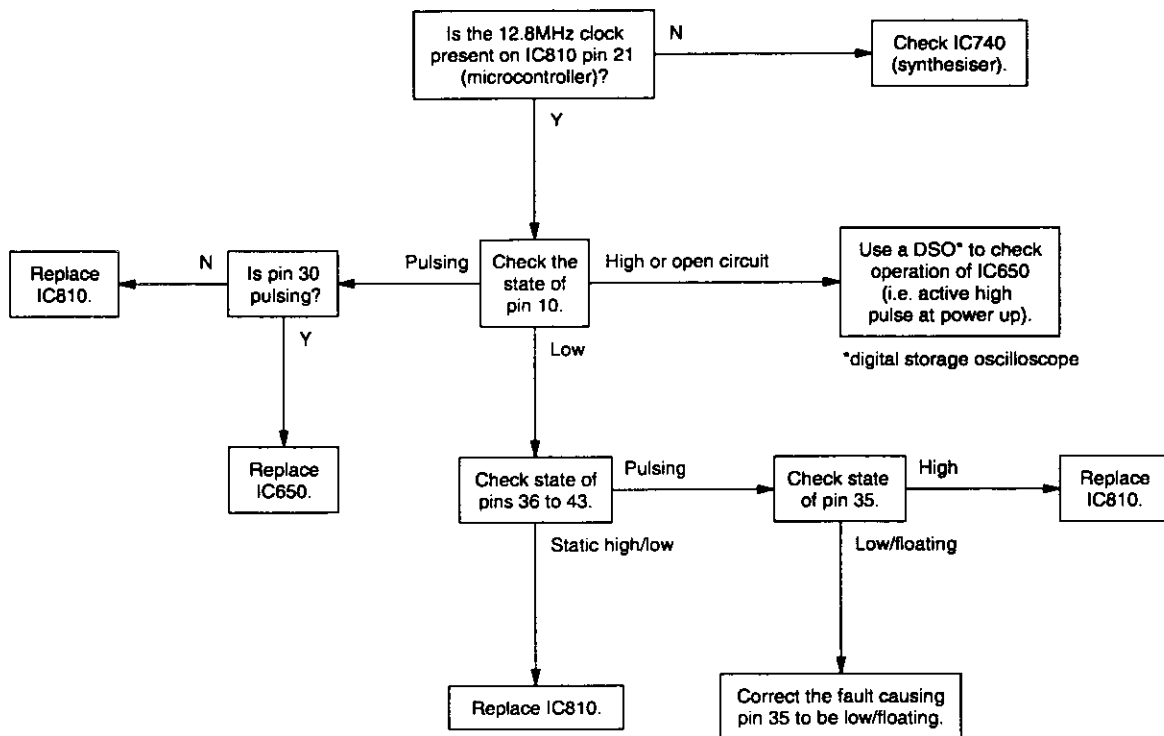

Connect the exciter output to a power meter and key the exciter.

Check that the output power is between 600 and 1000mW.

**Note:** If the synthesiser is out of lock, the lock detector (synthesiser IC740 and comparator IC750) will prevent the RF signal from reaching the PA by switching the supply to the exciter amplifier (Q340, Q345).

#### 5.5.4 Audio And Modulation

Refer to the audio processor fault finding chart (Section 5.7.7).

Set up the audio processor as described in Section 3.9.

Check that the demodulated RF output has the frequency response referred to in Section 4.5 with at least  $\pm 5\text{kHz}$  ( $\pm 4\text{kHz}$ ) [ $\pm 2.5\text{kHz}$ ] deviation available at 1kHz modulating frequency.

If the above result is not achieved, either the two modulators are incorrectly adjusted or a fault condition exists.

## 5.4 DC Checks

### 5.4.1 Power Rails

Refer to the test points and options diagrams in Section 6 for test point locations, and to the regulator fault finding chart (Section 5.7.2) for fault diagnosis.

Check the 13.8V (TP601) and 9V (TP602) supplies at their test points in the regulator compartment with a DMM.

Check the 5V (TP604) and 20V (TP603) rails at their respective test points in the regulator compartment.

Check that Tx-Reg. (TP305 in the exciter compartment) comes up to 8.8V when the exciter is keyed.

Check the +5V digital regulator output (TP607 in the regulator compartment).

Check for short circuits.

### 5.4.2 VCO Locking

Key the exciter.

Using a DMM, monitor the VCO control voltage at PL4-1 or the junction of L1 and R1 on the VCO PCB.

If the synthesiser is locked and the VCO aligned, the voltage at this point should be between 5 and 13V.

If the VCO is not locked, refer to the synthesiser fault finding chart (Section 5.7.3).

Section	Title	Page
5.7	Fault Finding Charts	5.8
5.7.1	Microcontroller	5.8
5.7.1.1	Basic Checks	5.8
5.7.1.2	Serial Communications	5.9
5.7.1.3	CTCSS Encode	5.10
5.7.2	Regulator	5.11
5.7.3	Synthesiser	5.12
5.7.4	T836 Drive Amplifier	5.15
5.7.5	T836 PA & Power Control	5.16
5.7.6	T837 Exciter Drive Amplifier	5.17
5.7.7	Audio Processor	5.18
5.8	To Replace The T836 PA Transistors (Q415 & Q425)	5.19

Figure	Title	Page
5.1	RF Diode Probe Circuit	5.5
5.2	Positioning Of Components Around Q425 & Q415	5.20



### Wide Bandwidth

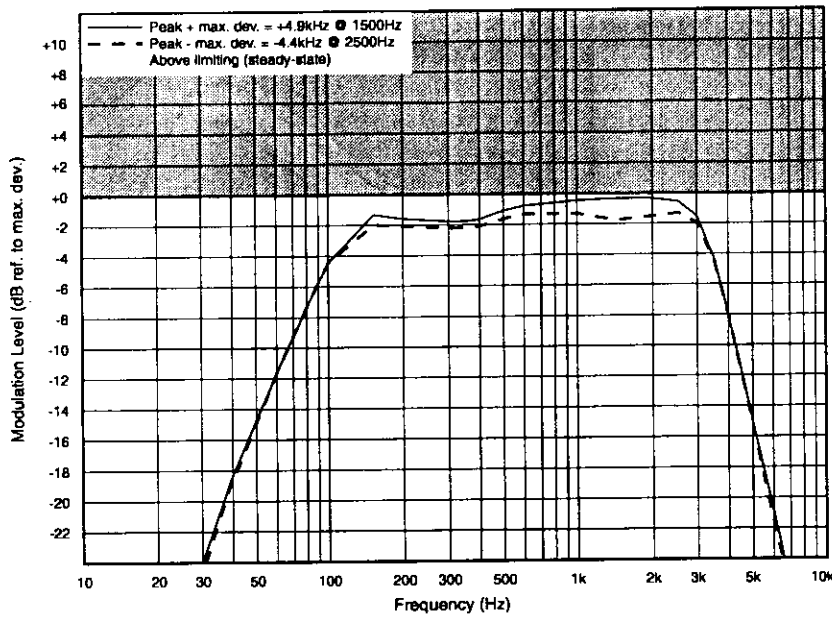

### Mid Bandwidth

The mid bandwidth graph is the same shape as the wide bandwidth graph. The deviation figures are as follows:

- peak + max. deviation = +4kHz
- peak - max. deviation = -4kHz.

### Narrow Bandwidth

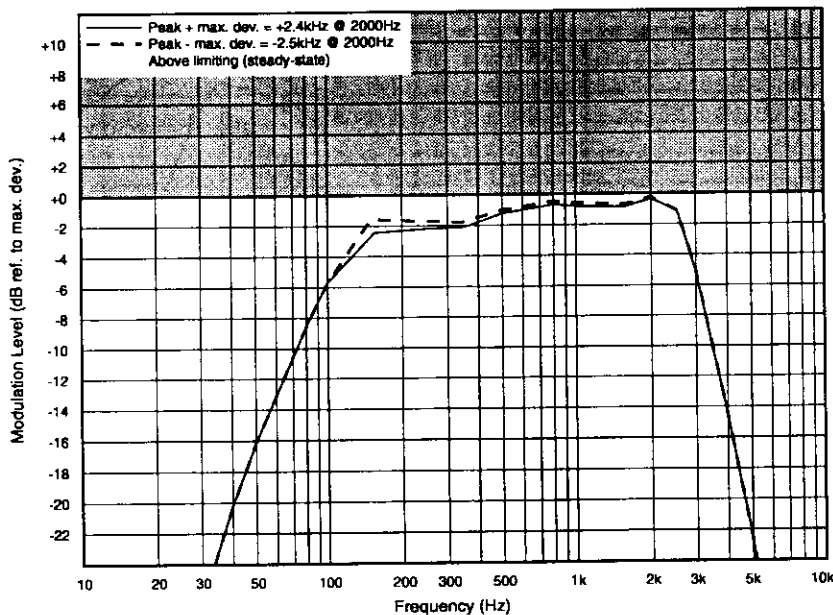

Figure 4.3 T836/837 Limiting Response

Timer	Function	Adjustment
Transmit Tail	Sets the tail time during which the transmitter stays keyed after the external key source has been removed.	0-5 seconds in 100ms steps
Transmit Timeout	Sets the maximum continuous transmission time. Once the timer has timed out, the transmitter must be keyed again, unless prevented by the transmit lockout timer.	0-300 seconds in 10 second steps
Transmit Lockout	Sets the period of time that must elapse after a timeout before the transmitter can re-transmit. Once the timer has timed out, the transmitter can be keyed again.	0-60 seconds in 10 second steps

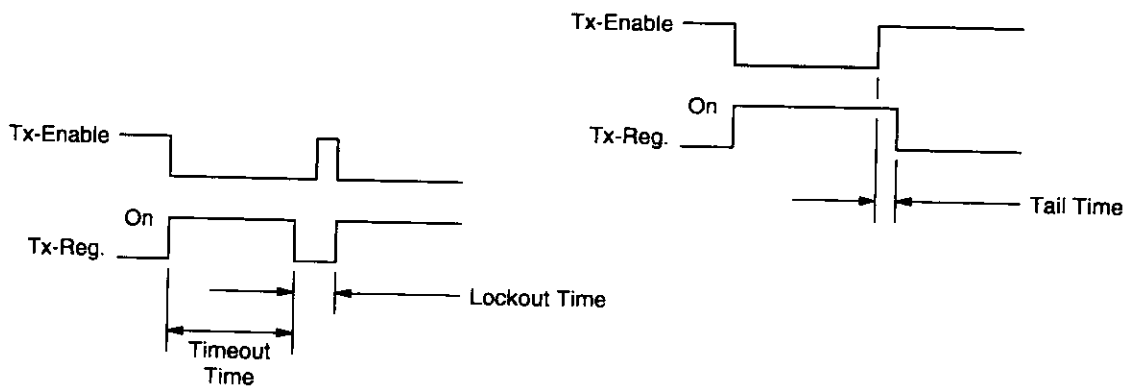

Figure 4.1 T836/837 Transmit Timers

## 4.5 Frequency Response

If the T836/837 has been correctly adjusted, the pre-emphasis and limiting responses should closely match those shown in Figure 4.2 and Figure 4.3 respectively.

**Note:** The limits shown on these graphs should not be exceeded.

- Measure the pre-emphasis response as follows:
  - Reduce the line level to give  $\pm 1\text{kHz}$  ( $\pm 0.8\text{kHz}$ ) [ $\pm 0.5\text{kHz}$ ] deviation at  $1\text{kHz}$ .
  - Sweep the modulation frequency.
  - The response should closely match that shown in Figure 4.2.
- Measure the limiting response as follows:
  - Set the line level to give  $\pm 3\text{kHz}$  ( $\pm 2.4\text{kHz}$ ) [ $\pm 1.5\text{kHz}$ ] deviation at  $1\text{kHz}$ .
  - Increase the line level  $20\text{dB}$  and sweep the modulation frequency.
  - The response should closely match that shown in Figure 4.3.







### 3.9.3 Limiter Adjustment

**Note:** If the T836/837 will be used over the whole 8MHz switching range, you must set the deviation for each channel. However, if the module will be used on frequencies that cover only a 1MHz (or less) switching range, you can set the deviation on the middle channel and use this value for all other channels with the "fill" option in PGM800Win.

Set the links in the audio processor section as required (refer to Section 3.5).

Inject 1kHz at -10dBm into the line input (D-range 1 (PL100) pins 1 & 4; and pins 2 & 3 shorted; refer to Section 2.2 of Part F).

Adjust RV210 (line sensitivity) fully clockwise and key the transmitter by earthing the Tx-Key line. Adjust "deviation" via PGM800Win to set the peak deviation to  $\pm 4.7\text{kHz}$  ( $\pm 3.8\text{kHz}$ ) [ $\pm 2.3\text{kHz}$ ] (you can use either the mouse or up and down arrow keys).

Sweep the audio frequency from 100Hz to 4kHz and ensure that the maximum deviation does not exceed 4.7kHz ( $\pm 3.8\text{kHz}$ ) [ $2.3\text{kHz}$ ]. Readjust "deviation" if necessary via PGM800Win.

### 3.9.4 Line Level Without Compressor

This section assumes that the compressor is not used. If the compressor is required, refer to Section 3.9.5.

Adjust the line sensitivity as follows:

- set the injected signal at the line input to the required line level (typically -10 to -20dBm);
- adjust RV210 (line sensitivity) to provide  $\pm 3\text{kHz}$  ( $\pm 2.4\text{kHz}$ ) [ $\pm 1.5\text{kHz}$ ] deviation.

### 3.9.5 Compressor

The compressor may be used on the line input only, the microphone input only, or on both the line and microphone inputs. If the compressor is used, refer to one of the following sections as appropriate.

#### 3.9.5.1 Compressor On Line Input Only

Set RV210 (line sensitivity) fully clockwise and key the transmitter by earthing the Tx-Key line.

Reduce the line level to -50dBm at 1kHz and set RV220 (compression level) fully clockwise.

### 3.7 PA Alignment (T836 Only)

Check that the exciter is connected to the PA with the coaxial link.

Connect an RF power meter to the PA output.

Turn RV320 (power adjust) fully clockwise.

Measure and record the voltage (VL) at L490; perform this measurement at room temperature so that the NTC (R460) is close to 25°C.

Key the transmitter by earthing the Tx-Key line.

Tune CV451 until maximum power is obtained.

Reduce the current by approximately 1A by detuning CV451 or until the power drops below 30W.

Check that the total current drawn is less than 4.5A for 25W output power.

Adjust RV320 for an output power between 5 and 25W.

### 3.8 Thermal Shutdown (T836 Only)

Key the transmitter by earthing the Tx-Key line and set the output power to 25W as described in Section 3.7.

Short L490 to ground.

Set RV330 (high temperature power adjust) for an output power of 5W.

Set RV310 (temperature adjust) to  $0.16V_L$  volts (measured at IC330 pin 5), where  $V_L$  is the voltage measured at L490 in Section 3.7. This sets the thermal shutdown at 85°C at NTC R460.

## 3.5 Audio Processor Links

### 3.5.1 Link Details

Use the following table to set up the audio processor to the configuration you require. You should set the audio processor links before carrying out any of the tuning and adjustment procedures. The factory settings are shown in brackets [ ].

Plug	Link <sup>a</sup>		Function
PL205	1-2	A	not connected
	[3-4]	B	microphone pre-amp. output to compressor input
	5-6	C	microphone pre-amp. output to multiplexer input
PL210	[1-2]	L	multiplexer output to pre-emphasis input
	3-4	M	multiplexer output to limiter input
	5-6	N	multiplexer output to compressor input
PL215	1-2	G	not connected
	[3-4]	H	compressor output to multiplexer input
	5-6	I	compressor output to limiter input
	7-8	J	compressor output to pre-emphasis input
PL220	9-10	K	not connected
	1-2	D	pre-emphasis output to multiplexer input
	[3-4]	E	pre-emphasis output to limiter input
	5-6	F	not connected

a. The letters in this column and in the table in Section 3.5.2 below refer to the identification letters screen printed onto the PCB beside each pair of pins.

### 3.5.2 Typical Options

	PL205	PL210	PL215	PL220
microphone pre-amp. compressed and pre-emphasised; line input pre-emphasised (standard set-up)	[3-4] B	[1-2] L	[3-4] H	[3-4] E
microphone pre-amp. compressed and pre-emphasised; line input unprocessed	3-4 B	3-4 M	7-8 J	1-2 D
line and microphone compressed and pre-emphasised	5-6 C	5-6 N	7-8 J	3-4 E
microphone pre-amp. compressed; line and microphone flat response	3-4 B	3-4 M	3-4 H	5-6 F

### 3.4.4 Two Point Modulation Adjustment

**Note 1:** In this and following sections deviation settings are given first for wide bandwidth sets, followed by settings in brackets for mid bandwidth sets ( ) and narrow bandwidth sets [ ].

**Note 2:** Reference modulation and limiter adjustment are controlled by PGM800Win. Electronic potentiometers (256 step) are used to allow channel-by-channel adjustment of deviation and two point modulation.

**Note 3:** To optimise the modulation response across the switching range, repeat steps 1-4 below for each channel that will be used (usually needed only for data applications). In applications where the modulation response is less critical (e.g. voice use only), carry out steps 1-4 below on the middle channel and cut and paste the value to all other channels.

1. Inject an audio signal of 600Hz 1.5V rms (+5dBm) into the CTCSS input (D-range 1 (PL100) pin 8).

Key the transmitter by earthing the Tx-Key line.

2. Adjust the output from the audio generator to obtain  $\pm 3\text{kHz}$  ( $\pm 2.4\text{kHz}$ ) [ $\pm 1.5\text{kHz}$ ] deviation at 600Hz.

3. Change the input frequency to 120Hz and adjust "reference modulation" via PGM800Win to obtain  $\pm 3\text{kHz}$  ( $\pm 2.4\text{kHz}$ ) [ $\pm 1.5\text{kHz}$ ] deviation (you can use either the mouse or up and down arrow keys).

4. Change the input frequency back to 600Hz.

Repeat steps 2 and 3 above until the deviations achieved at the two input frequencies are within 0.2dB of each other. You will need to do this at least four times.

5. Sweep the audio between 50 and 300Hz for peaks.

**Note:** A peak between 50 and 300Hz will indicate a fault condition, i.e:

- incorrect set-up
- or - modulation circuitry fault.

The specification window is  $\pm 1\text{dB}$  relative to 150Hz from 65 to 260Hz.

### 3.4.5 FM Deviation (Limiter) Adjustment

**Note:** If the T836/837 will be used over the whole 8MHz switching range, you must set the deviation for each channel. However, if the module will be used on frequencies that cover only a 1MHz (or less) switching range, you can set the deviation on the middle channel and use this value for all other channels with the "fill" option in PGM800Win.

Inject 1kHz at -10dBm into the line input (D-range 1 (PL100) pins 1 & 4; pins 2 & 3 shorted; refer to Section 2.2 of Part F).

### 3.3 Test Equipment Required

You will need the following test equipment:

- computer with PGM800Win installed
  - T800 programming kit
  - module programming interface (e.g. T800-01-0004 - optional)
  - 13.8V power supply
  - digital multimeter
  - audio signal generator
  - RF power meter
  - audio voltmeter x 2
  - modulation meter
  - oscilloscope (digital preferred)
  - 20dB pad
  - T800-01-0010 calibration test unit (optional)
- } or RF test set (optional)

Figure 3.1 and Figure 3.2 show typical test equipment set-ups.

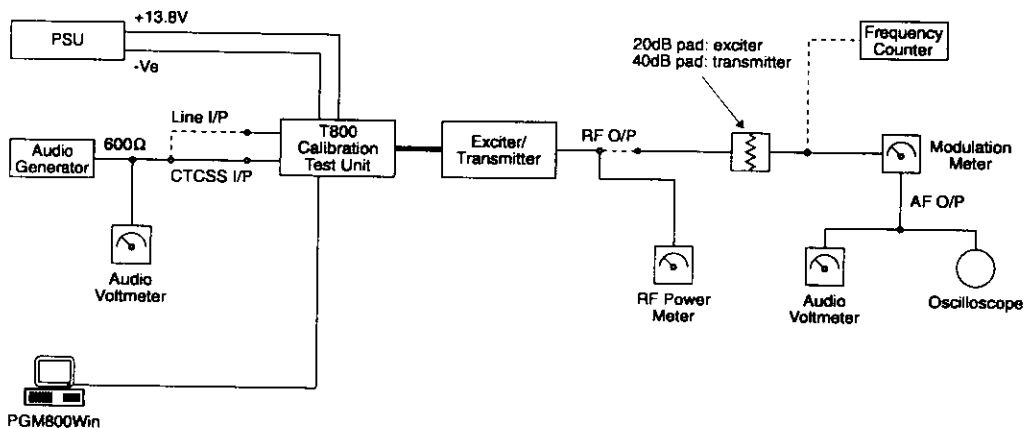

Figure 3.1 T836/837 Test Equipment Set-up With T800-01-0010

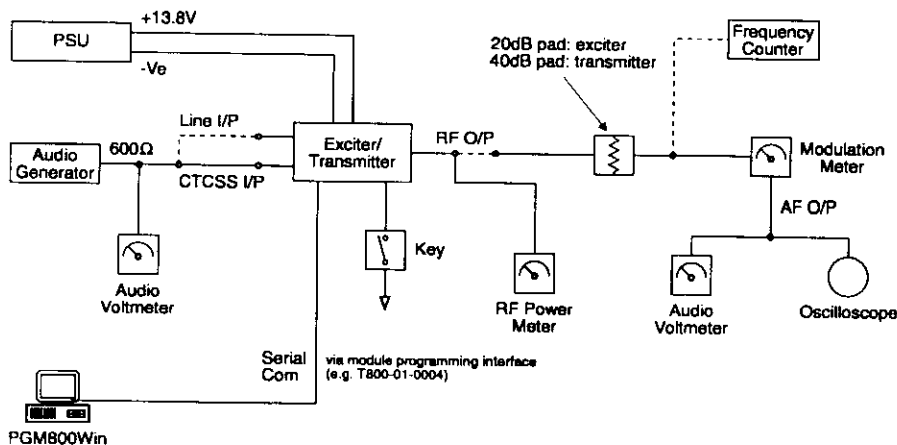

Figure 3.2 T836/837 Test Equipment Set-up Without T800-01-0010

Section	Title	Page
3.7	PA Alignment (T836 Only)	3.10
3.8	Thermal Shutdown (T836 Only)	3.10
3.9	Audio Processor	3.11
3.9.1	Two Point Modulation	3.11
3.9.2	Modulator Adjustment	3.11
3.9.3	Limiter Adjustment	3.12
3.9.4	Line Level Without Compressor	3.12
3.9.5	Compressor	3.12
3.9.5.1	Compressor On Line Input Only	3.12
3.9.5.2	Compressor On Microphone Input Only	3.13
3.9.5.3	Compressor On Both Line & Microphone Inputs	3.13

Figure	Title	Page
3.1	T836/837 Test Equipment Set-up With T800-01-0010	3.4
3.2	T836/837 Test Equipment Set-up Without T800-01-0010	3.4





## 2.8 T836 Drive Amplifier & PA

(Refer to Figure 2.1 and the exciter and PA circuit diagrams (sheets 3 & 4) in Section 6.2.)

The output power of the PA is maintained at a constant level via a power control loop applied to the two-stage, wide band exciter amplifier (Q365, Q370). The forward and reverse RF power levels are sensed via a dual directional coupler and detector diodes (D410, D420 in the PA cavity). The detected DC signals are summed with the 'power adjust' level and fed to the control integrator (IC330 pins 1, 2 & 3). The output control voltage is buffered by Q310 and Q315, and applied to the collectors of the wide band exciter amplifier.

**Note:** Forward and reflected power signals are summed so that, under high VSWR, the power control will turn the output RF level down.

To reduce the spurious output level when the synthesiser is out-of-lock, the Tx-Reg. and Lock-Detect signals are gated to inhibit the PA control circuit and to switch off the RF signal at the input to the drive amplifier. This is achieved by a PIN switch attenuator (D340, D350, D360).

Cyclic keying control is provided by additional circuitry consisting of several time delay, ramp and gate stages:

- Q350, Q355, Q360, IC330 pins 1, 2 & 3      power ramping
- Q340, Q345      Tx-Reg. and  $\overline{\text{Lock-Detect}}$  gate
- Q320, Q325, Q330, Q335      delay and PIN switch drive.

This is to allow the RF power circuits (both exciter and PA) to ramp up and down in a controlled manner so that minimal adjacent channel interference is generated during the transition.

The output of the wide band amplifier is approximately 500mW (+27dBm) for an input of 170mW (+22dBm) when the power control is set to maximum.

The zener diode (D330) limits the upper range of the controlled voltage to the exciter transistors.

A temperature sensor (R460) is provided so that the RF output power can be reduced to a preset level when a set temperature is exceeded. This is a protection circuit (IC330 pins 5, 6 & 7, Q305) to prevent overheating, as the unit is *not* rated for continuous operation at high temperatures (refer to Section 1.2.3 for duty cycle specifications). RV330 sets the PA output power while under high temperature fold-back conditions.

R359, R360 and R362 form a 6dB attenuator to provide good VCO/exciter isolation.

The output attenuator (R392, R390, R394 and R396) aids in reducing exciter/PA interaction while also ensuring a reasonable match for Q350.

The RF output from the exciter is fed to the driver stage (Q415) and then to the final (Q425). DC is fed to the final via a low pass filter with special low frequency decoupling. CV451 tunes the output matching across the entire band.

## 2.6 Power Supply & Regulator Circuits

(Refer to the regulators circuit diagram (sheet 6) in Section 6.2 or 6.3.)

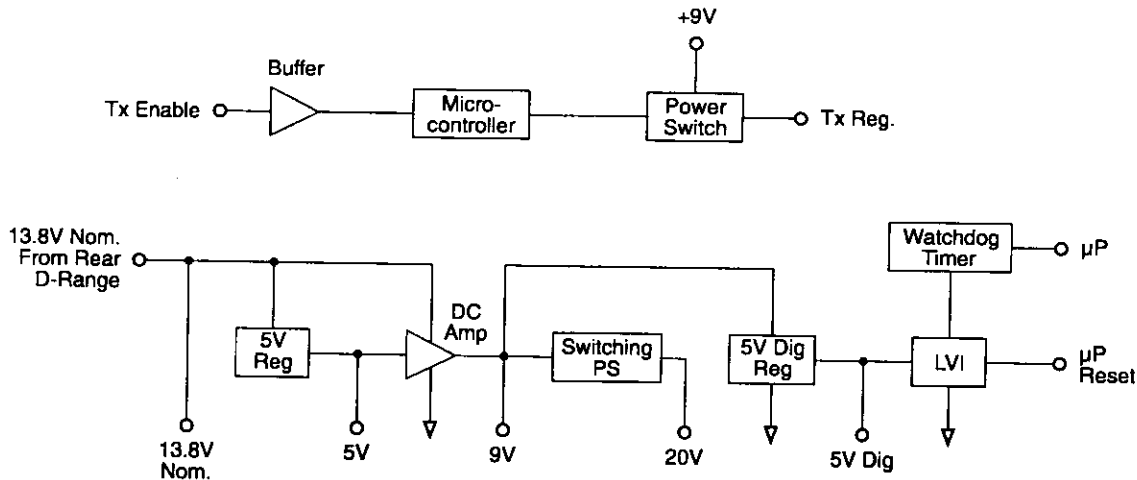

**Figure 2.7 T836/837 Power Supply & Regulators Block Diagram**

The T836 and T837 are designed to operate from a 10.8-16V DC supply (13.8V nominal). A 5.3V regulator (IC630) runs directly from the 13.8V rail, driving much of the synthesiser circuitry. It is also used as the reference for a DC amplifier (IC640, Q630, Q620) which provides a medium current capability 9V supply.

A switching power supply (Q660, Q670) runs from the 9V supply and provides a low current capability +20V supply. This is used to drive the synthesiser loop filter (IC750), giving a VCO control voltage range of up to 20V, and the Lock-Detect amplifiers.

Ultimate control of the transmitter is via the Tx-Reg. supply, switched from 9V by Q610. This is enabled via the Tx-Enable signal from the audio processor, and microprocessor.

## 2.5 Audio Processor

(Refer to the audio processor circuit diagram (sheet 2) in Section 6.2 or 6.3.)

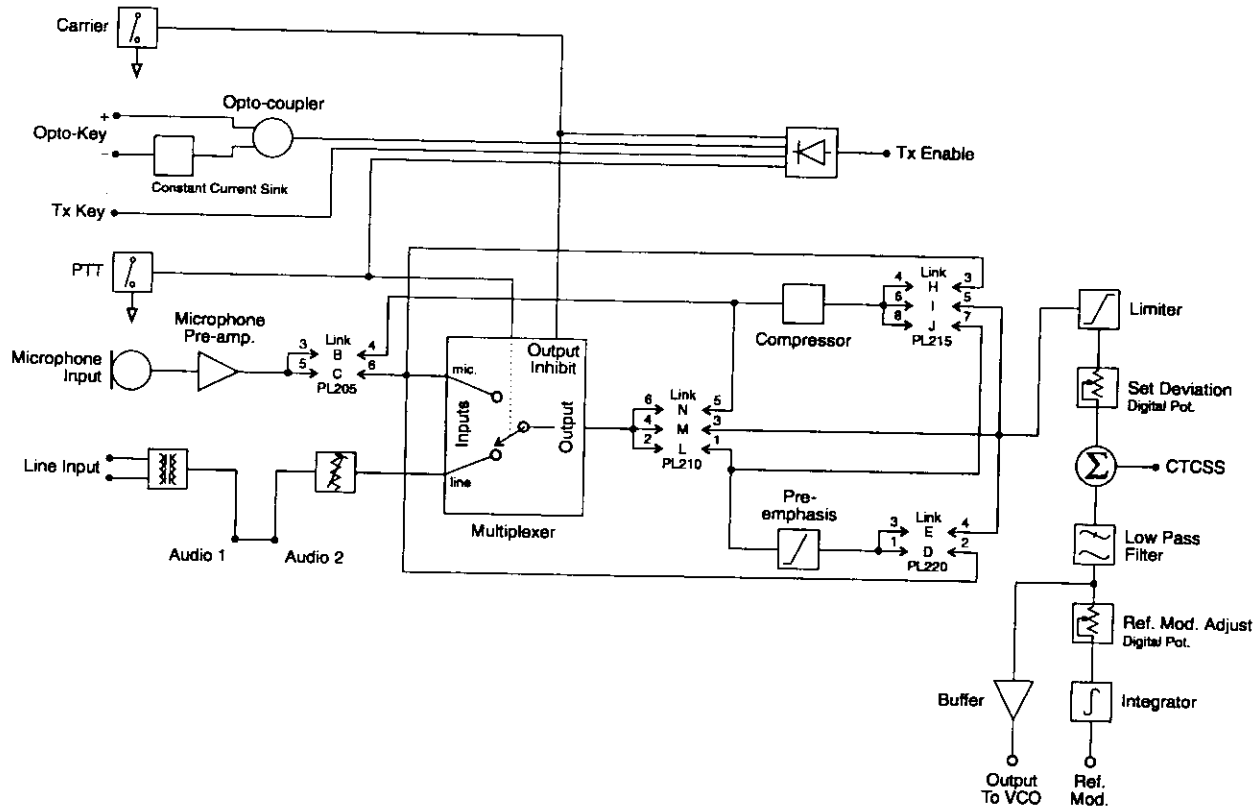

Figure 2.6 T836/837 Audio Processor Block Diagram

### 2.5.1 General

The audio processor comprises several link selectable circuit blocks which may be configured in a variety of combinations to suit individual requirements. The pre-emphasis network and compressor may be linked individually or cascaded between either or both audio inputs and the limiter.

Refer to Section 3.5.1 for linking details.

### 2.5.2 Audio Inputs

Two audio inputs are available: one from a 600 ohm balanced (or unbalanced) line, and the other from a local microphone. The microphone signal is passed first to a pre-amplifier (Q210) and ultimately to a multiplexer (IC240), but in between may pass through the compressor (depending on the linking details). The line transformer is also connected to the multiplexer and is disabled by the microphone PTT switch.

A third input for external CTCSS tones is also provided.

### 2.3.1 Two Point Modulation

Frequency modulation occurs by modulating both the VCO input and the synthesiser reference input. This process is called two point modulation and ensures a flat modulation response from 67Hz to 3kHz (2.55kHz for narrow bandwidth).

The PLL has a fast response time, allowing a Tx key-up time of <30ms. Because of this fast response time the PLL sees lower modulation frequencies superimposed on the VCO as an error and corrects for it, resulting in no modulation on the carrier. At modulation frequencies greater than 300Hz the loop cannot correct fast enough and modulation is seen on the carrier. The response of the loop to VCO modulation is shown by  $f_2$  in Figure 2.5 below.

To achieve low frequency modulation, the reference oscillator is also modulated so that the phase detector of IC740 detects no frequency error under modulation. Thus, the synthesiser loop will not attempt to correct for modulation and the audio frequency response of the transmitter remains unaffected. The response of the loop to reference frequency modulation is shown by  $f_1$  in Figure 2.5.

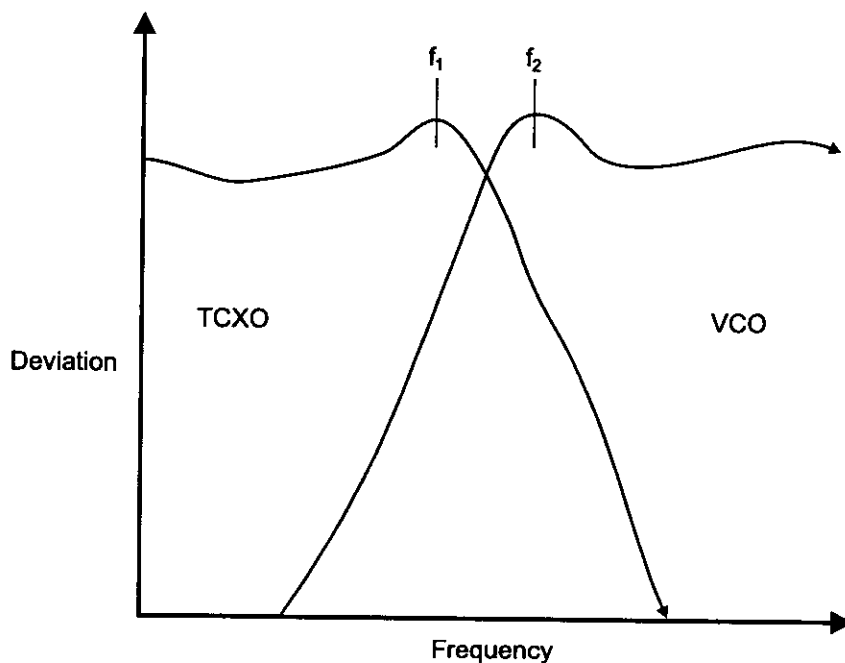

Figure 2.5 T836/837 Two Point Modulation

## 2.2 Microcontroller

(Refer to the microcontroller circuit diagram (sheet 8) in Section 6.2 or 6.3.)

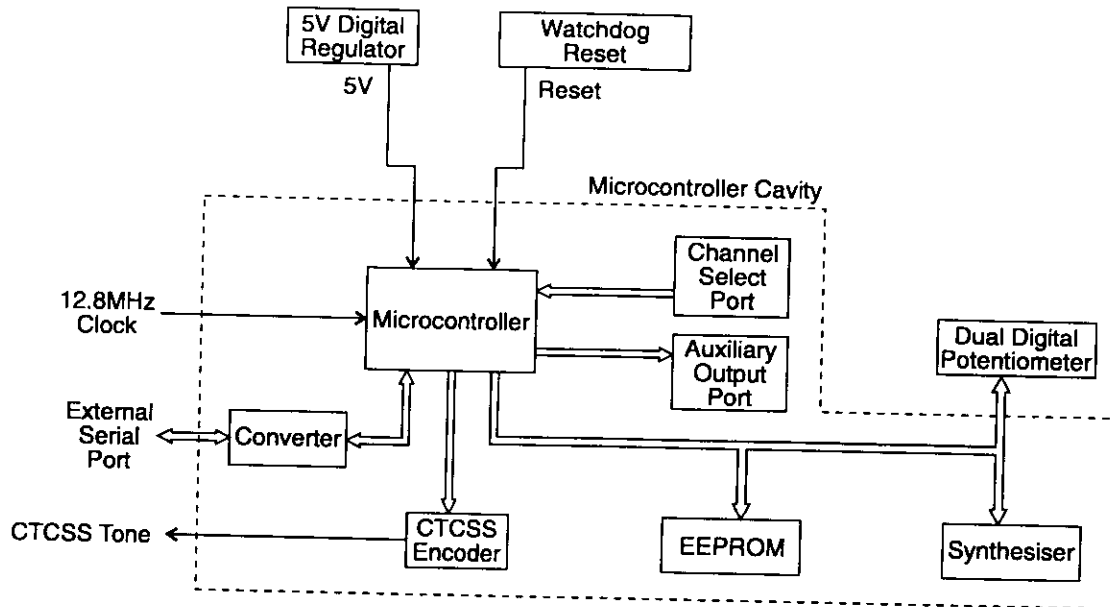

Figure 2.3 T836/837 Microcontroller Block Diagram

Overall system control of the T836/837 is accomplished by the use of a member of the 80C51 family of microcontrollers (IC810). It runs from internal ROM and RAM, thus leaving all four ports free for input/output functions.

Non-volatile data storage is achieved by serial communication with a 16kBit EEPROM (IC820). This serial bus is also used by the microcontroller to program the synthesiser (IC740) and deviation control EPOTS (IC220).

The main tasks of the microcontroller are as follows:

- program the synthesiser and EPOT;
- interface with the PGM800Win programming software at 9600 baud via the serial communication lines on D-range 1 (PL100) & D-range 2;
- monitor channel change inputs from D-range 2;
- generate timing waveforms for CTCSS encoding;
- coordinate and implement timing control of the exciter/transmitter.

Figure	Title	Page
2.1	T836 High Level Block Diagram	2.3
2.2	T837 High Level Block Diagram	2.3
2.3	T836/837 Microcontroller Block Diagram	2.4
2.4	T836/837 Synthesiser Block Diagram	2.5
2.5	T836/837 Two Point Modulation	2.6
2.6	T836/837 Audio Processor Block Diagram	2.8
2.7	T836/837 Power Supply & Regulators Block Diagram	2.10
2.8	T836/837 Transmit Timers	2.11





## 1.4 T836 Standard Product Range

The following table lists the range of standard T836 types (i.e. no options fitted) available at the time this manual was published. Consult your nearest Tait Dealer or Subsidiary for more information.

Frequency Range (MHz)	136-156			
Deviation (kHz)	2.5	2.5	4	5
TCXO <sup>a</sup> ±2.5ppm -30°C to +60°C	•	•	•	•
Transmitter Type: T836-	16-0000 <sup>b</sup>	15-0000	13-0000	10-0000

Frequency Range (MHz)	148-174			
Deviation (kHz)	2.5	2.5	4	5
TCXO <sup>a</sup> ±2.5ppm -30°C to +60°C	•	•	•	•
Transmitter Type: T836-	26-0000 <sup>b</sup>	25-0000	23-0000	20-0000

- a. A TCXO with a stability of ±1ppm (0°C to +60°C) is available to suit specific requirements. Contact your nearest authorised Tait Dealer or Subsidiary for further details.
- b. United States market only.

You can identify the transmitter type by checking the product code printed on a label on the rear of the chassis (Figure 1.1 in Part A shows typical labels). You can further verify the transmitter type by checking the placement of an SMD resistor in the table that is screen printed onto the PCB (refer to Section 6.1 for more details).

## 1.2.6 Test Standards

Where applicable, this equipment is tested in accordance with the following standards.

### 1.2.6.1 European Telecommunication Standard

#### ETS 300 086 January 1991

Radio equipment and systems; land mobile service; technical characteristics and test conditions for radio equipment with an internal or external RF connector intended primarily for analogue speech.

#### ETS 300 113 March 1996

Radio equipment and systems; land mobile service; technical characteristics and test conditions for radio equipment intended for the transmission of data (and speech) and having an antenna connector.

#### ETS 300 219 October 1993

Radio equipment and systems; land mobile service; technical characteristics and test conditions for radio equipment transmitting signals to initiate a specific response in the receiver.

#### ETS 300 279 February 1996

Radio equipment and systems; electromagnetic compatibility (EMC) standard for private land mobile radio (PMR) and ancillary equipment (speech and/or non-speech).

### 1.2.6.2 DTI CEPT Recommendation T/R-24-01

#### Annex I: 1988

Technical characteristics and test conditions for radio equipment in the land mobile service intended primarily for analogue speech.

#### Annex II: 1988

Technical characteristics of radio equipment in the land mobile service with regard to quality and stability of transmission.

### 1.2.6.3 Telecommunications Industry Association

#### ANSI/TIA/EIA-603-1992

Land mobile FM or PM communications equipment measurement and performance standards.

Intermodulation .. -40dBc with interfering signal of  
-30dBc  
.. -70dBc with 25dB isolation  
& interfering signal of -30dBc  
(PA with output isolator)

T836 Mismatch Capability:

Ruggedness .. refer to your nearest Tait Dealer or  
Subsidiary  
Stability .. 3:1 VSWR (all phase angles)

Radiated Spurious Emissions:

Transmit .. -36dBm to 1GHz  
-30dBm to 4GHz  
Standby .. -57dBm to 1GHz  
-47dBm to 4GHz

Conducted Spurious Emissions: (T836 Only)

Transmit .. -36dBm to 1GHz  
-30dBm to 4GHz  
Standby .. -57dBm to 1GHz  
-47dBm to 4GHz

Power Output:

T836 - Rated Power .. 25W  
- Range Of Adjustment .. 5-25W  
T837 .. 800mW  $\pm$ 200mW

Duty Cycle (T836 Only) .. 100% @ 25W at +25°C  
.. 30% @ 25W at +60°C  
.. 100% @ 10W at +60°C

## 1.2.4 Audio Processor

### 1.2.4.1 Inputs

Inputs Available .. line, microphone and CTCSS

Line Input:

Impedance .. 600 ohms (balanced)  
Sensitivity (60% modulation @ 1kHz)-  
With Compressor .. -50dBm  
Without Compressor .. -30dBm

Microphone Input:

Impedance .. 600 ohms  
Sensitivity (60% modulation @ 1kHz)-  
With Compressor .. -70dBm  
Without Compressor .. -50dBm

## 1.2 Specifications

### 1.2.1 Introduction

The performance figures given are minimum figures, unless otherwise indicated, for equipment tuned with the maximum switching range and operating at standard room temperature (+22°C to +28°C) and standard test voltage (13.8V DC).

Where applicable, the test methods used to obtain the following performance figures are those described in the EIA and ETS specifications. However, there are several parameters for which performance according to the CEPT specification is given. Refer to Section 1.2.6 for details of test standards.

Details of test methods and the conditions which apply for Type Approval testing in all countries can be obtained from Tait Electronics Ltd.

The terms "wide bandwidth", "mid bandwidth" and "narrow bandwidth" used in this and following sections are defined in the following table.

	Channel Spacing	Modulation 100% Deviation	Receiver IF Bandwidth
Wide Bandwidth	25kHz	±5.0kHz	15.0kHz
Mid Bandwidth	20kHz	±4.0kHz	12.0kHz
Narrow Bandwidth	12.5kHz	±2.5kHz	7.5kHz

### 1.2.2 General

Number Of Channels .. 128 (standard)<sup>1</sup>

#### Supply Voltage:

Operating Voltage .. 10.8 to 16V DC  
 Standard Test Voltage .. 13.8V DC  
 Polarity .. negative earth only  
 Polarity Protection .. diode  
 Line Keying Supply (if required) .. -50V DC

#### Supply Current:

Transmit - T836 .. 4.5A (typical)  
 - T837 .. 600mA  
 Standby .. 150mA (typical)

Operating Temperature Range .. -30°C to +60°C

1. Additional channels may be factory programmed. Contact your nearest Tait Dealer or Subsidiary.

