

# 1 T856/857 General Information

This section provides a brief description of the T856 transmitter and T857 exciter, along with detailed specifications and a list of types available.

The following topics are covered in this section.

Section	Title	Page
<b>1.1</b>	<b>Introduction</b>	<b>1.7</b>
<b>1.2</b>	<b>Specifications</b>	<b>1.8</b>
1.2.1	Introduction	1.8
1.2.2	General	1.8
1.2.3	RF Section	1.9
1.2.4	Audio Processor	1.10
1.2.4.1	Inputs	1.10
1.2.4.2	Modulation Characteristics	1.11
1.2.4.3	CTCSS	1.11
1.2.5	Microcontroller	1.11
1.2.6	Test Standards	1.12
1.2.6.1	European Telecommunication Standard	1.12
1.2.6.2	DTI CEPT Recommendation T/R-24-01	1.12
1.2.6.3	Telecommunications Industry Association	1.12
<b>1.3</b>	<b>Product Codes</b>	<b>1.13</b>
<b>1.4</b>	<b>T856 Standard Product Range</b>	<b>1.14</b>
<b>1.5</b>	<b>T857 Standard Product Range</b>	<b>1.15</b>

Figure	Title	Page
1.1	T856 Main Circuit Block Identification	1.4
1.2	T856 Front Panel Controls	1.4
1.3	T857 Main Circuit Block Identification	1.6
1.4	T857 Front Panel Controls	1.6



**replace A4 pages C1.3/C1.4 with A3 pages C1.3/C1.4**

**replace A4 pages C1.3/C1.4 with A3 pages C1.3/C1.4**

**replace A4 pages C1.5/C1.6 with A3 pages C1.5/C1.6**

**replace A4 pages C1.5/C1.6 with A3 pages C1.5/C1.6**

## 1.1 Introduction

The T856 is a synthesised, microprocessor controlled FM base station transmitter designed for single or multichannel operation in the 400 to 520MHz frequency range<sup>1</sup> with a standard power output of 25W. The RF section of the transmitter comprises a frequency synthesiser which provides 100mW of frequency modulated RF drive to a two stage, wide band output driver followed by a 25W power amplifier. A thermal shut-down feature is provided in the T856 in case operating temperatures exceed acceptable levels.

The T857 is a synthesised, microprocessor controlled FM base station exciter designed for single or multichannel operation in the 400 to 520MHz frequency range<sup>1</sup>. With a standard power output of only 1W, the exciter is designed for use with the T858 50W or T859 100W power amplifiers. The RF section of the exciter comprises a frequency synthesiser which provides 100mW of frequency modulated RF drive to a two stage, wide band output amplifier.

A wide selection of audio characteristics may be obtained from the audio processor. Optional circuit blocks are an audio compressor and a pre-emphasis stage. They can be bypassed or linked to one or both audio inputs, and then back into the remaining audio circuitry in almost any combination. All audio processor options are link selectable.

The synthesiser frequency is programmed via the serial communications port. Eight channel select lines are accessible via an optional D-range connector (D-range 2 - T800-03-0000) at the rear of the set.

All components except those of the VCO are mounted on a single PCB. This is secured to a die-cast chassis which is divided into compartments to individually shield each section of circuitry. Access to both sides of the main circuit board is obtained by removing each of the chassis lids. There is provision within the chassis to mount small option PCBs.

The front panel controls include line sensitivity, microphone socket and carrier switch. This switch turns on the carrier (unmodulated) as an aid to servicing.

The T856 and T857 are both 60mm wide and each occupies a single space in a Tait rack frame, which has the ability to accommodate up to seven standard modules.

---

1. Although capable of operating over the 400-520MHz frequency range, the T856 and T857 have an 8MHz switching range (see Section 1.2.3 and Section 3.1).

## 1.2 Specifications

### 1.2.1 Introduction

The performance figures given are minimum figures, unless otherwise indicated, for equipment tuned with the maximum switching range and operating at standard room temperature (+22°C to +28°C) and standard test voltage (13.8V DC).

Where applicable, the test methods used to obtain the following performance figures are those described in the EIA and ETS specifications. However, there are several parameters for which performance according to the CEPT specification is given. Refer to Section 1.2.6 for details of test standards.

Details of test methods and the conditions which apply for Type Approval testing in all countries can be obtained from Tait Electronics Ltd.

The terms "wide bandwidth", "mid bandwidth" and "narrow bandwidth" used in this and following sections are defined in the following table.

	Channel Spacing	Modulation 100% Deviation	Receiver IF Bandwidth
Wide Bandwidth	25kHz	±5.0kHz	15.0kHz
Mid Bandwidth	20kHz	±4.0kHz	12.0kHz
Narrow Bandwidth	12.5kHz	±2.5kHz	7.5kHz

### 1.2.2 General

Number Of Channels .. 128 (standard)<sup>1</sup>

Supply Voltage:

Operating Voltage	.. 10.8 to 16V DC
Standard Test Voltage	.. 13.8V DC
Polarity	.. negative earth only
Polarity Protection	.. diode

Supply Current:

Transmit	- T856	.. 5.5A (typical)
	- T857	.. 750mA
Standby	- T856	.. 165mA (typical)
	- T857	.. 150mA (typical)

Operating Temperature Range .. -20°C to +60°C

1. Additional channels may be factory programmed. Contact your nearest Tait Dealer or Customer Service Organisation.



## Dimensions:

Height	.. 183mm
Width	.. 60mm
Length	.. 320mm

Weight .. 2.1kg

Time-Out Timer (optional) .. 0 to 5 minutes adjustable in 10 second steps

Tail Timer .. 0 to 5 seconds adjustable in 100ms steps

Transmit Key Time .. <30ms

Transmit Lockout Timer .. 0 to 1 minute adjustable in 10 second steps

### 1.2.3 RF Section

Frequency Range .. 400-520MHz (refer to Section 1.4 and Section 1.5)

Modulation Type .. FM

Frequency Increment .. 5 or 6.25kHz

Switching Range .. 8MHz (i.e.  $\pm 4$ MHz from the centre frequency)

Load Impedance .. 50 ohms

Frequency Stability ..  $\pm 1$ ppm,  $-20^{\circ}\text{C}$  to  $+60^{\circ}\text{C}$   
(see also Section 1.4 and Section 1.5)

Adjacent Channel Power (full deviation):

Wide Bandwidth (WB) ( $\pm 25$ kHz/ $15$ kHz B/W)	.. -75dBc
Mid Bandwidth (MB) ( $\pm 20$ kHz/ $12$ kHz B/W)	.. -70dBc
Narrow Bandwidth (NB) ( $\pm 12.5$ kHz/ $7.5$ kHz B/W)	.. -65dBc

(Transmitter switching must comply with ETS 300 113)

Transmitter Side Band Noise:

(no modulation, 15kHz bandwidth)

At $\pm 25$ kHz	.. -95dBc
At $\pm 1$ MHz	.. -105dBc

Intermodulation	.. -40dBc with interfering signal of -30dBc .. -70dBc with 25dB isolation & interfering signal of -30dBc (PA with output isolator)
T856 Mismatch Capability:	
Ruggedness	.. refer to your nearest Tait Dealer or Customer Service Organisation
Stability	.. 3:1 VSWR (all phase angles)
Radiated Spurious Emissions:	
Transmit	.. -36dBm to 1GHz .. -30dBm 1GHz to 4GHz
Standby	.. -57dBm to 1GHz .. -47dBm 1GHz to 4GHz
Conducted Spurious Emissions: (T856 Only)	
Transmit	.. -36dBm to 1GHz .. -30dBm 1GHz to 4GHz
Standby	.. -57dBm to 1GHz .. -47dBm 1GHz to 4GHz
Power Output:	
T856 - Rated Power	.. 25W (see Duty Cycle)
- Range Of Adjustment	.. 5-25W
T857	.. 1W ±300mW
Duty Cycle (T856 Only)	.. 100% @ 25W at +25°C .. 25% @ 25W at +60°C .. 100% @ 10W at +40°C

## 1.2.4 Audio Processor

### 1.2.4.1 Inputs

Inputs Available	.. line, microphone and CTCSS
Line Input:	
Impedance	.. 600 ohms (balanced)
Sensitivity (60% modulation @ 1kHz)- With Compressor	.. -50dBm
Without Compressor	.. -30dBm
Microphone Input:	
Impedance	.. 600 ohms
Sensitivity (60% modulation @ 1kHz)- With Compressor	.. -70dBm
Without Compressor	.. -50dBm

**1.2.4.2 Modulation Characteristics**

Frequency Response (below limiting) .. flat or pre-emphasised (optional)

Line And Microphone Inputs:

Pre-emphasised Response-Bandwidth .. 300Hz to 3kHz (WB & MB)  
 .. 300Hz to 2.55kHz (NB)  
 Below Limiting .. within +1, -3dB of a 6dB/octave pre-emphasis characteristic  
 Flat Response .. within +1, -2dB of output at 1kHz

Above Limiting Response .. within +1, -2dB of a flat response (ref. 1kHz)

Distortion .. 2%

Hum And Noise:

Wide Bandwidth .. -55dB (300Hz to 3kHz [EIA]) typical  
 Mid Bandwidth .. -54dB (CEPT)  
 Narrow Bandwidth .. -50dB (CEPT)

Compressor (optional):

Attack Time .. 10ms  
 Decay Time .. 800ms  
 Range .. 50dB

**1.2.4.3 CTCSS**

Standard Tones .. all 37 EIA group A, B and C tones plus 13 commonly used tones

Frequency Error (from EIA tones) .. 0.08% max.

Generated Tone Distortion .. 1.2% max.

Generated Tone Flatness .. flat across 67 to 250.3Hz to within 1dB

Modulation Level .. adjustable

Modulated Distortion .. <5%

**1.2.5 Microcontroller**

Auxiliary Ports:

Open Drain Type .. capable of sinking 2.25mA via 2k $\Omega$   
 $V_{ds}$  max. .. 5V

## **1.2.6 Test Standards**

Where applicable, this equipment is tested in accordance with the following standards.

### **1.2.6.1 European Telecommunication Standard**

#### **ETS 300 086 January 1991**

Radio equipment and systems; land mobile service; technical characteristics and test conditions for radio equipment with an internal or external RF connector intended primarily for analogue speech.

#### **ETS 300 113 March 1996**

Radio equipment and systems; land mobile service; technical characteristics and test conditions for radio equipment intended for the transmission of data (and speech) and having an antenna connector.

#### **ETS 300 219 October 1993**

Radio equipment and systems; land mobile service; technical characteristics and test conditions for radio equipment transmitting signals to initiate a specific response in the receiver.

#### **ETS 300 279 February 1996**

Radio equipment and systems; electromagnetic compatibility (EMC) standard for private land mobile radio (PMR) and ancillary equipment (speech and/or non-speech).

### **1.2.6.2 DTI CEPT Recommendation T/R-24-01**

#### **Annex I: 1988**

Technical characteristics and test conditions for radio equipment in the land mobile service intended primarily for analogue speech.

#### **Annex II: 1988**

Technical characteristics of radio equipment in the land mobile service with regard to quality and stability of transmission.

### **1.2.6.3 Telecommunications Industry Association**

#### **ANSI/TIA/EIA-603-1992**

Land mobile FM or PM communications equipment measurement and performance standards.

## 1.3 Product Codes

The three groups of digits in the T850 Series II product code provide information about the model, type and options fitted, according to the conventions described below.

The following explanation of T850 Series II product codes is not intended to suggest that any combination of features is necessarily available in any one product. Consult your nearest Tait Dealer or Customer Service Organisation for more information regarding the availability of specific models, types and options.

### Model

The Model group indicates the basic function of the product, as follows:

<u>T85X</u> -XX-XXXX	T855 receiver
	T856 25W transmitter
	T857 exciter
	T858 50W power amplifier
	T859 100W power amplifier

### Type

The Type group uses two digits to indicate the basic RF configuration of the product.

The first digit in the Type group designates the frequency range:

T85X- <u>X</u> -XXXX	'1' for 400-440MHz
	'2' for 440-480MHz
	'3' for 480-520MHz

The second digit in the Type group indicates the channel spacing:

T85X- <u>XX</u> -XXXX	'0' for wide bandwidth (25kHz)
	'3' for mid bandwidth (20kHz)
	'5' for narrow bandwidth (12.5kHz)

### Options

T85X-XX- <u>XXXX</u>	The Options group uses four digits and/or letters to indicate any options that may be fitted to the product. This includes standard options and special options for specific customers. '0000' indicates a standard Tait product with no options fitted. The large number of options precludes listing them here.
----------------------	---

## 1.4 T856 Standard Product Range

The following table lists the range of standard T856 types (i.e. no options fitted) available at the time this manual was published. Consult your nearest Tait Dealer or Customer Service Organisation for more information.

Frequency Range (MHz)		400-440			
Deviation (kHz)		2.5	2.5	4	5
TCXO	±1ppm -20°C to +60°C	•	•	•	•
Transmitter Type: T856-		16-0000 <sup>a</sup>	15-0000	13-0000	10-0000

Frequency Range (MHz)		440-480			
Deviation (kHz)		2.5	2.5	4	5
TCXO	±1ppm -20°C to +60°C	•	•	•	•
Transmitter Type: T856-		26-0000 <sup>a</sup>	25-0000	23-0000	20-0000

Frequency Range (MHz)		480-512		480-520
Deviation		2.5	2.5	5
TXCO	±1ppm -20° to +60°C	•	•	•
Transmitter Type: T856-		36-0000 <sup>a</sup>	35-0000	30-0000

a. United States market only.

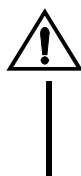

### Caution: T856-1X-XXXX Product Types

The 406 to 406.1MHz frequency range is reserved worldwide for use by Distress Beacons. *Do not* program transmitters to operate in this frequency range.

You can identify the transmitter type by checking the product code printed on a label on the rear of the chassis (Figure 1.1 in Part A shows typical labels). You can further verify the transmitter type by checking the placement of an SMD resistor in the table that is screen printed onto the PCB (refer to Section 6.1 for more details).

## 1.5 T857 Standard Product Range

The following table lists the range of standard T857 types (i.e. no options fitted and cyclic keying disabled) available at the time this manual was published. Consult your nearest Tait Dealer or Customer Service Organisation for more information.

Frequency Range (MHz)	400-440			
Deviation (kHz)	2.5	2.5	4	5
TCXO	±1ppm -20°C to +60°C			
Exciter Type: T857-	16-0000 <sup>a</sup>	15-0000	13-0000	10-0000

Frequency Range (MHz)	440-480			
Deviation (kHz)	2.5	2.5	4	5
TCXO	±1ppm -20°C to +60°C			
Exciter Type: T857-	26-0000 <sup>a</sup>	25-0000	23-0000	20-0000

Frequency Range (MHz)	480-512		480-520
Deviation	2.5	2.5	5
TXCO	±1ppm -20° to +60°C		
Exciter Type: T857-	36-0000 <sup>a</sup>	35-0000	30-0000

a. United States market only.



### **Caution:** T857-1X-XXXX Product Types

The 406 to 406.1MHz frequency range is reserved worldwide for use by Distress Beacons. *Do not* program excitors to operate in this frequency range.

You can identify the exciter type by checking the product code printed on a label on the rear of the chassis (Figure 1.1 in Part A shows typical labels). You can further verify the exciter type by checking the placement of an SMD resistor in the table that is screen printed onto the PCB (refer to Section 6.1 for more details).





## 2 T856/857 Circuit Operation

This section provides a basic description of the circuit operation of the T856 transmitter and T857 exciter.

**Note:** Unless otherwise specified, the term "PGM800Win" used in this and following sections refers to version 2.00 and later of the software.

Refer to Section 6 where the parts lists, grid reference index and diagrams will provide detailed information on identifying and locating components and test points on the main PCB. The parts list and diagrams for the VCO PCB are in Part E.

The following topics are covered in this section.

Section	Title	Page
2.1	<b>Introduction</b>	2.3
2.2	<b>Microcontroller</b>	2.4
2.3	<b>Synthesised Local Oscillator</b>	2.5
2.3.1	Two Point Modulation	2.6
2.4	<b>VCO</b>	2.7
2.4.1	VCO Supply	2.7
2.5	<b>Audio Processor</b>	2.8
2.5.1	General	2.8
2.5.2	Audio Inputs	2.8
2.5.3	Keying Inputs	2.9
2.5.4	Compressor (Automatic Level Control (ALC))	2.9
2.5.5	Outputs To Modulators	2.9
2.6	<b>Power Supply &amp; Regulator Circuits</b>	2.10
2.7	<b>Transmit Timers</b>	2.11
2.8	<b>T856 Drive Amplifier &amp; PA</b>	2.12
2.9	<b>T857 Exciter Drive Amplifier</b>	2.13

Figure	Title	Page
2.1	T856 High Level Block Diagram	2.3
2.2	T857 High Level Block Diagram	2.3
2.3	T856/857 Microcontroller Block Diagram	2.4
2.4	T856/857 Synthesiser Block Diagram	2.5
2.5	T856/857 Two Point Modulation	2.6
2.6	T856/857 Audio Processor Block Diagram	2.8
2.7	T856/857 Power Supply & Regulators Block Diagram	2.10
2.8	T856/857 Transmit Timers	2.11

## 2.1 Introduction

The individual circuit blocks which make up the T856 and T857 are:

- synthesiser
- VCO
- audio processor
- drive amplifier
- power amplifier (T856 only)
- voltage regulators.

Each of these circuit blocks is set in its own shielded compartment, formed as an integral part of the main chassis.

The configuration of the circuit blocks may be seen on a functional level in Figure 2.1 and Figure 2.2. Refer to the circuit diagrams in Section 6.2 (T856) or 6.3 (T857) for more detail.

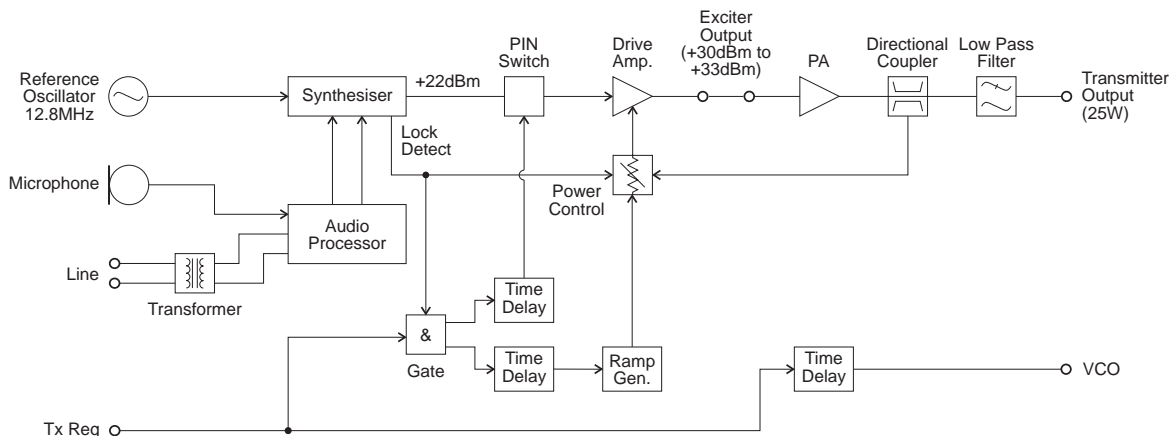

Figure 2.1 T856 High Level Block Diagram

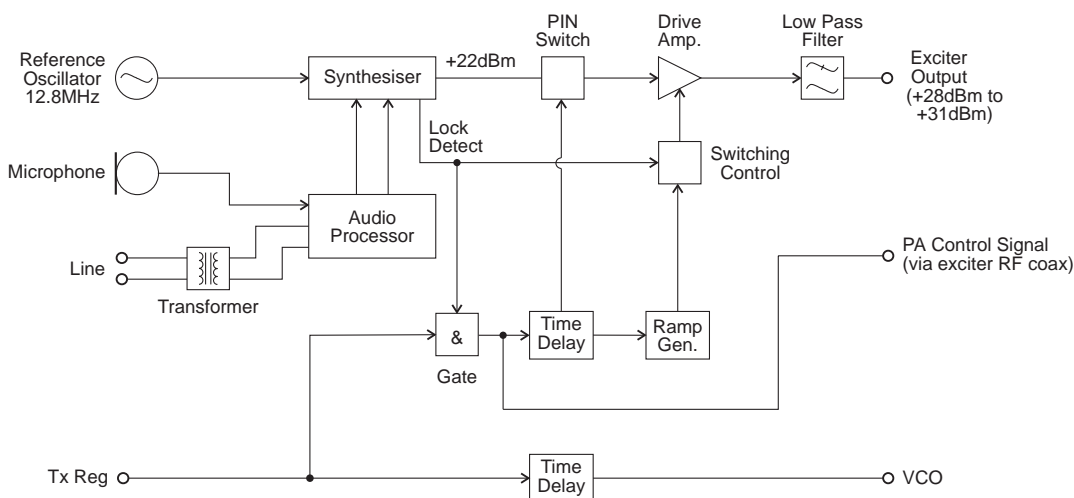
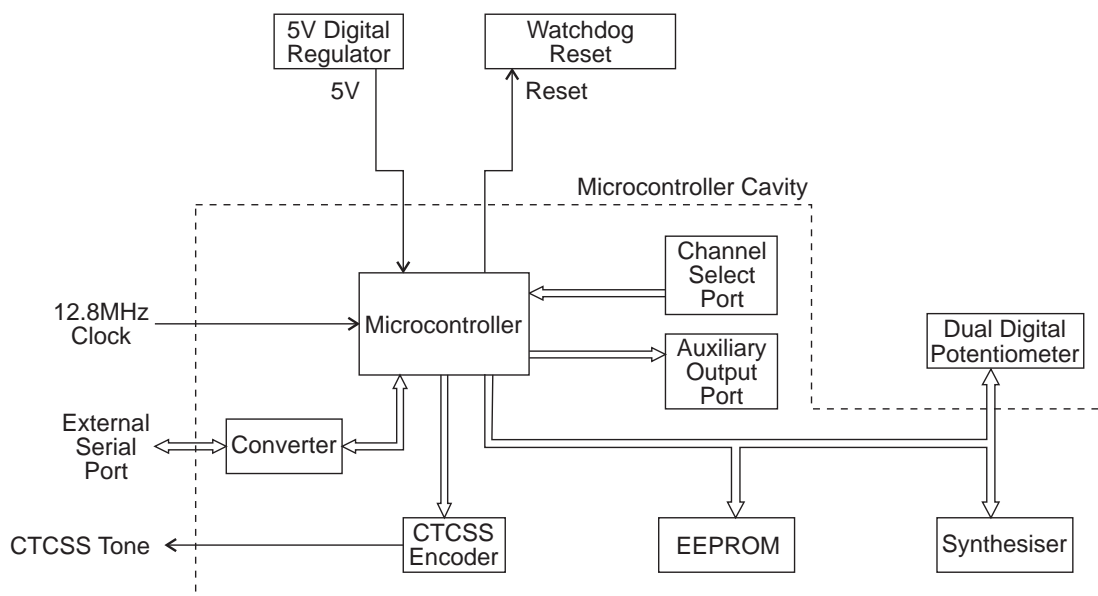

Figure 2.2 T857 High Level Block Diagram

## 2.2 Microcontroller

(Refer to the microcontroller circuit diagram (sheet 8) in Section 6.2 or 6.3.)



**Figure 2.3 T856/857 Microcontroller Block Diagram**

Overall system control of the T856/857 is accomplished by the use of a member of the 80C51 family of microcontrollers (IC810). It runs from internal ROM and RAM, thus leaving all four ports free for input/output functions.

Non-volatile data storage is achieved by serial communication with a 16kBit EEPROM (IC820). This serial bus is also used by the microcontroller to program the synthesiser (IC740) and deviation control EPOTS (IC220).

The main tasks of the microcontroller are as follows:

- program the synthesiser and EPOT;
- interface with the PGM800Win programming software at 9600 baud via the serial communication lines on D-range 1 (PL100) & D-range 2;
- monitor channel change inputs from D-range 2;
- generate timing waveforms for CTCSS encoding;
- coordinate and implement timing control of the exciter/transmitter.

## 2.3 Synthesised Local Oscillator

(Refer to the synthesiser circuit diagram (sheet 7) in Section 6.2 or 6.3 and the VCO circuit diagram in Part E.)

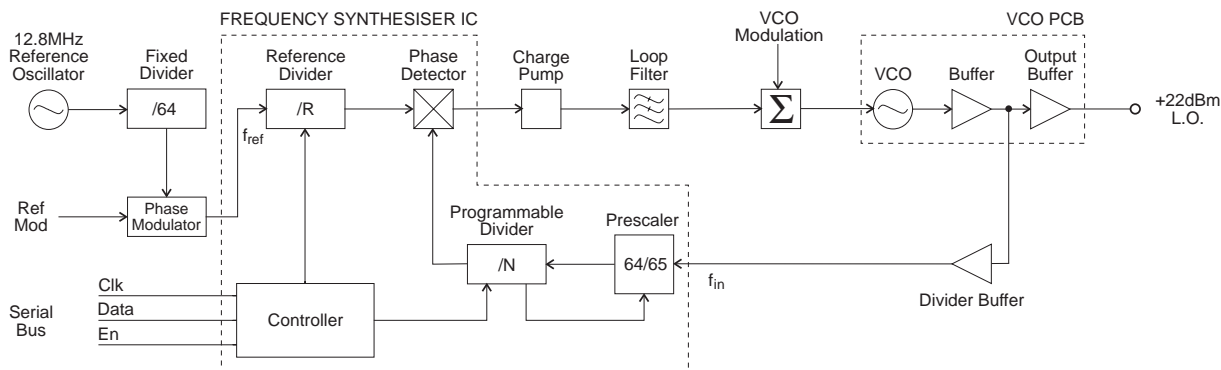

**Figure 2.4 T856/857 Synthesiser Block Diagram**

The synthesiser (IC740) employs a phase-locked loop (PLL) to lock a voltage controlled oscillator (VCO) to a given reference frequency. The synthesiser receives the divider information from the control microprocessor via a 3 wire serial bus (clock, data, enable). When the data has been latched in, the synthesiser processes the incoming signals from the VCO buffer ( $f_{in}$ ) and the phase modulator ( $f_{ref}$ ).

A reference oscillator at 12.8MHz (=IC700) is buffered (IC710 pins 3 & 4) and divided down to 200kHz (IC730). This 200kHz square wave is then summed with the modulating audio and passed to an integrator (IC720 pins 9 & 8, Q710, Q720). This produces a ramping waveform which is centred around a DC level determined by the incoming audio. IC720 pins 5 & 6 perform as a comparator, ultimately producing a phase-modulated 200kHz square wave. This is followed by another phase shifting stage (IC720 pins 3 & 4, Q730, Q740), before being divided down to 6.25kHz or 5kHz within the synthesiser IC (IC740).

A buffered output of the VCO (Q795) is divided with a prescaler and programmable divider which is incorporated into the synthesiser chip (IC740). This signal is compared with the phase modulated reference signal at the phase detector (also part of the synthesiser chip). The phase detector outputs drive a balanced charge pump circuit (Q760, Q770, Q775, Q780, Q785) and active loop filter (IC750 pins 5, 6 & 7, Q790) which produces a DC voltage between 0V and 20V to tune the VCO. This VCO control line is further filtered to attenuate noise and other spurious signals. Note that the VCO frequency increases with increasing control voltage.

If the synthesiser loop loses lock, a pulsed signal appears at LD (pin 2) of IC740. This signal is filtered and buffered by IC750 pins 1, 2 & 3, producing the Lock-Detect signal used to shut off the power supply to the drive amplifier. IC750 pin 1 is at 20V when the synthesiser is out of lock.

### 2.3.1 Two Point Modulation

Frequency modulation occurs by modulating both the VCO input and the synthesiser reference input. This process is called two point modulation and ensures a flat modulation response from 67Hz to 3kHz (2.55kHz for narrow bandwidth).

The PLL has a fast response time, allowing a Tx key-up time of <30ms. Because of this fast response time the PLL sees lower modulation frequencies superimposed on the VCO as an error and corrects for it, resulting in no modulation on the carrier. At modulation frequencies greater than 300Hz the loop cannot correct fast enough and modulation is seen on the carrier. The response of the loop to VCO modulation is shown by  $f_2$  in Figure 2.5 below.

To achieve low frequency modulation, the reference oscillator is also modulated so that the phase detector of IC740 detects no frequency error under modulation. Thus, the synthesiser loop will not attempt to correct for modulation and the audio frequency response of the transmitter remains unaffected. The response of the loop to reference frequency modulation is shown by  $f_1$  in Figure 2.5.

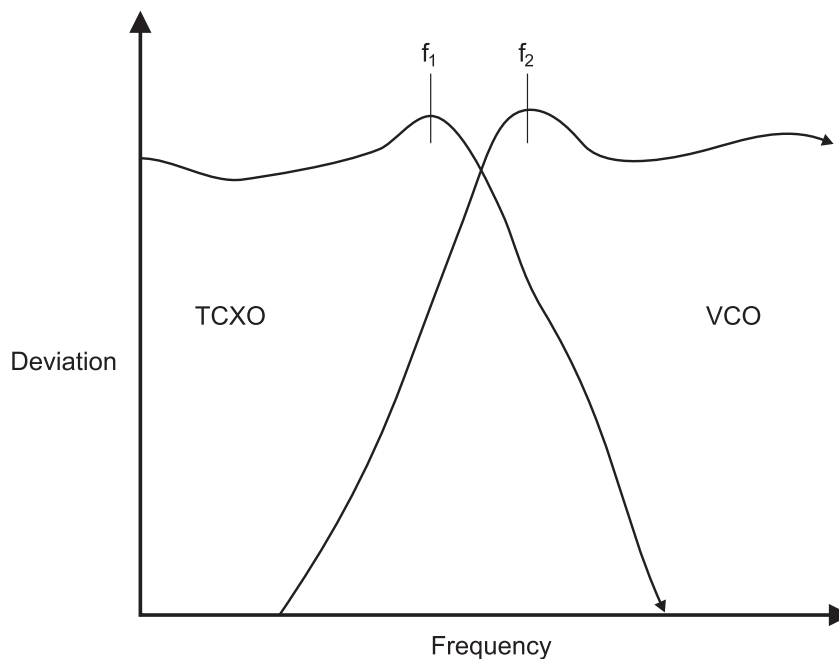

Figure 2.5 T856/857 Two Point Modulation

## 2.4 VCO

(Refer to the VCO circuit diagram in Part E.)

The VCO transistor (Q1) operates in a common emitter configuration, with an LC tank circuit coupled between its gate and drain to provide the feedback necessary for oscillation. The VCO control voltage from the loop filter (IC750) is applied to the varicaps (D1-D2) to facilitate tuning within an 8MHz band of frequencies. A trimcap (C6) is used for coarse tuning of the VCO. The output from the oscillator circuit drives a cascode amplifier stage (Q2, Q3) which supplies +10dBm (typically) to a further stage of amplification, Q5. This is the final amplifier on the VCO PCB, and delivers +20dBm (typically) to the exciter drive amplifier.

A low level "sniff" is taken from the input to Q5 and used to drive the divider buffer for the synthesiser (IC740).

The VCO operates at the actual output frequency of the exciter, i.e. there are no multiplier stages. It is modulated by superimposing the audio signal onto the control voltage and by phase modulating the reference signal.

### 2.4.1 VCO Supply

The VCO is supplied from two switched +9V supplies under the control of the Tx-Reg. supply.

The VCO and buffer amplifier are supplied from one +9V switched supply by Q540 via the C multiplier (Q550, C530 on the T856 and C550 on the T857).

The output amplifier is supplied from the other +9V supply by Q520, Q530, and Q510.

A delay circuit holds the VCO on for a short time after the Tx-Reg. supply has been switched off. This is to allow the RF power circuits (both exciter and PA) to ramp down in the correct manner before the VCO is switched off.

## 2.5 Audio Processor

(Refer to the audio processor circuit diagram (sheet 2) in Section 6.2 or 6.3.)

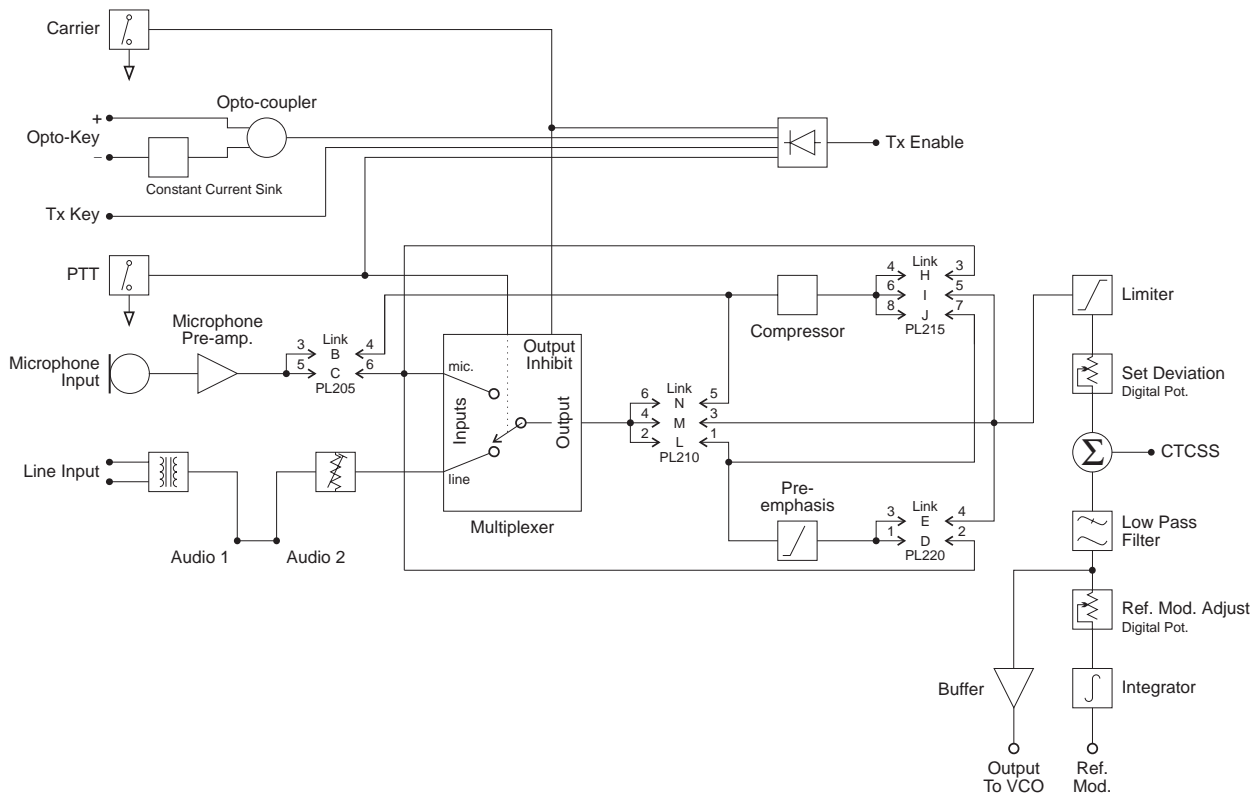

Figure 2.6 T856/857 Audio Processor Block Diagram

### 2.5.1 General

The audio processor comprises several link selectable circuit blocks which may be configured in a variety of combinations to suit individual requirements. The pre-emphasis network and compressor may be linked individually or cascaded between either or both audio inputs and the limiter.

Refer to Section 3.5.1 for linking details.

### 2.5.2 Audio Inputs

Two audio inputs are available: one from a 600 ohm balanced (or unbalanced) line, and the other from a local microphone. The microphone signal is passed first to a pre-amplifier (Q210) and ultimately to a multiplexer (IC240), but in between may pass through the compressor (depending on the linking details). The line transformer is also connected to the multiplexer and is disabled by the microphone PTT switch.

A third input for external CTCSS tones is also provided.



### 2.5.3 Keying Inputs

There are four ways to key the exciter:

- pulling the Tx-Key line low (pin 13 on D-range 1 [PL100]) at the rear of the set);
- pushing the "Carrier" button on the front panel - this will inhibit all audio;
- using the PTT button on the local microphone, disabling audio from the line;
- via the opto-key inputs (pins 11 and 12 on D-range 1 [PL100]) when electrical isolation is required. This features a constant current sink (Q270) to ensure reliable activation of the opto-coupler (IC250) at low keying voltages.

### 2.5.4 Compressor (Automatic Level Control (ALC))

The input signal is fed via a current controlled attenuator (Q230, Q220) to a high gain stage (IC230) from which the output signal is taken. This signal is passed to a comparator (IC230) which toggles whenever the audio signal exceeds a DC threshold determined by RV220. Thus, the comparator produces a square wave whose mark-space ratio is determined by the amplitude of the audio signal. This square wave pumps up the reservoir capacitor (C233) which controls the attenuator (Q230, Q220), thus completing the feedback loop.

The compression level is set by adjustment of the comparator threshold (RV220).

**Note:** Although the high dynamic range of the compressor allows the use of very low audio signal levels, such conditions will be accompanied by a degradation of the signal-to-noise ratio. Very low audio input levels should therefore be avoided where possible.

### 2.5.5 Outputs To Modulators

The output signal from the limiter (IC210, IC230) is summed with a CTCSS tone at a summing amplifier (IC260). The signal is then low pass filtered (IC260) and split to supply the two modulators.

Since the VCO modulator is a true frequency modulator, its audio is simply buffered (IC260). The reference modulator, however, is a phase modulator and its audio must first be integrated (IC210).

It is vital that the audio levels to the modulators are accurately set, *relative to each other*. Hence the inclusion of level adjustment in the reference modulator path. Once set, adjustments to absolute deviation may be made only via the deviation digital pot. (IC220 - adjustable via PGM800Win).

## 2.6 Power Supply & Regulator Circuits

(Refer to the regulators circuit diagram (sheet 6) in Section 6.2 or 6.3.)

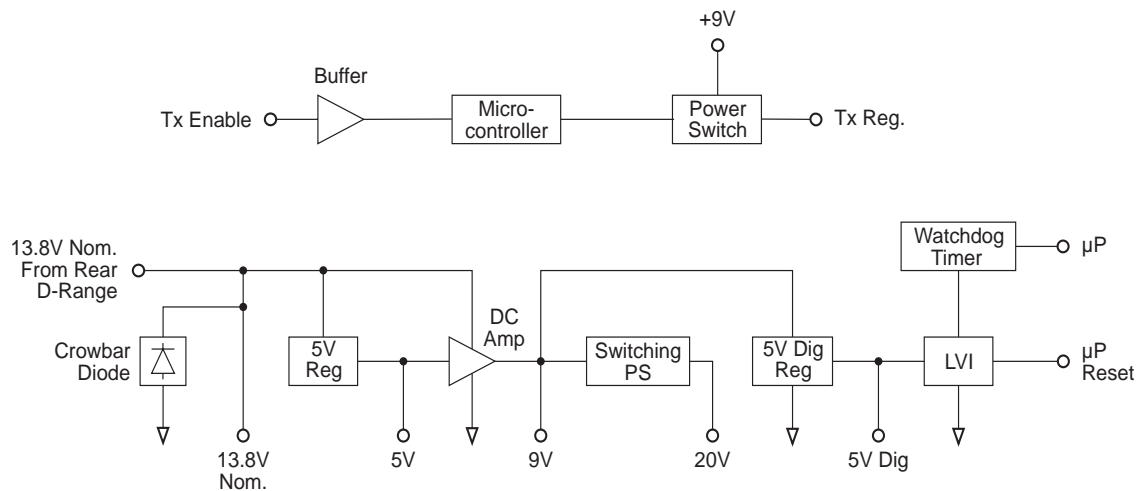

**Figure 2.7 T856/857 Power Supply & Regulators Block Diagram**

The T856 and T857 are designed to operate from a 10.8-16V DC supply (13.8V nominal). A 5.3V regulator (IC630) runs directly from the 13.8V rail, driving much of the synthesiser circuitry. It is also used as the reference for a DC amplifier (IC640, Q630, Q620) which provides a medium current capability 9V supply. The T856 has a regulator (IC370) which produces 9V for use in the exciter and audio circuits.

A switching power supply (Q660, Q670) runs from the 9V supply and provides a low current capability +20V supply. This is used to drive the synthesiser loop filter (IC750), giving a VCO control voltage range of up to 20V.

Ultimate control of the transmitter is via the Tx-Reg. supply, switched from 9V by Q610. This is enabled via the Tx-Enable signal from the audio processor, and microprocessor.

## 2.7 Transmit Timers

The transmit tail timer, transmit timeout timer and transmit lockout timer can all be set from PGM800Win. The fields for setting these are found on the system information page. These three timers operate as follows (refer also to Figure 2.8):

Timer	Function	Adjustment
Transmit Tail	Sets the tail time during which the transmitter stays keyed after the external key source has been removed.	0-5 seconds in 100ms steps
Transmit Timeout	Sets the maximum continuous transmission time. Once the timer has timed out, the transmitter must be keyed again, unless prevented by the transmit lockout timer.	0-300 seconds in 10 second steps
Transmit Lockout	Sets the period of time that must elapse after a timeout before the transmitter can re-transmit. Once the timer has timed out, the transmitter can be keyed again.	0-60 seconds in 10 second steps

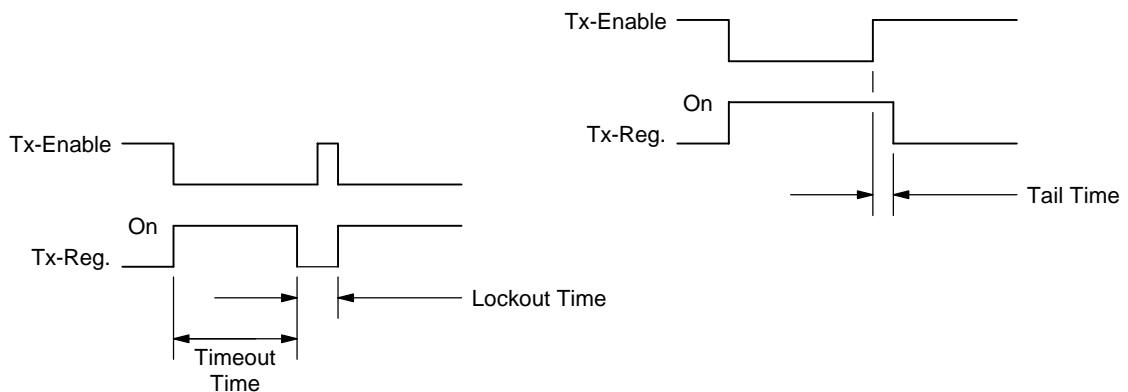

Figure 2.8 T856/857 Transmit Timers

## 2.8 T856 Drive Amplifier & PA

(Refer to Figure 2.1 and the exciter and PA circuit diagrams (sheets 3 & 4) in Section 6.2.)

The output power of the PA is maintained at a constant level via a power control loop applied to the two-stage, wide band exciter amplifier (Q350, Q355). The forward and reverse RF power levels are sensed via a dual directional coupler and detector diodes (D440, D420 in the PA cavity). The detected DC signals are buffered (IC330 pins 3 & 5) and then summed with the 'power control' level and fed to the control integrator (IC350 pin 6). The output control voltage is buffered by Q310 and Q315, and applied to the collector of the wide band exciter amplifier.

**Note:** Forward and reflected power signals are summed so that, under high VSWR, the power control will turn the output RF level down.

To reduce the spurious output level when the synthesiser is out-of-lock, the Tx-Reg. and Lock-Detect signals are gated to inhibit the PA control circuit and to switch off the RF signal at the input to the drive amplifier. This is achieved by a PIN switch attenuator (D340, D380, D360).

Cyclic keying control is provided by additional circuitry consisting of several time delay, ramp and gate stages:

- Q325, IC350 power ramping
- Q355, Q325 Tx-Reg. and  $\overline{\text{Lock-Detect}}$  gate
- Q335, Q340, Q345 delay and PIN switch drive.

This is to allow the RF power circuits (both exciter and PA) to ramp up and down in a controlled manner so that minimal adjacent channel interference is generated during the transition.

The output of the wide band amplifier is approximately 1W (+30dBm) for an input of 100mW (+20dBm) from the VCO, when the power control is set to maximum.

A temperature sensor (R481) is provided so that the RF output power can be reduced to a preset level when a set temperature is exceeded. This is a protection circuit (IC350 pin 1, Q320) to prevent overheating, as the unit is *not* rated for continuous operation (refer to Section 1.2.3 for duty cycle specifications).

#R517, #R518 and #R519 form an attenuator to provide good VCO/exciter isolation as well as the correct exciter drive level.

The attenuator (#R395, #R396 and #R397) aids in producing the correct exciter drive level to the PA over the three frequency ranges.

The RF output from the exciter is fed to the driver stage (Q410) and then to the final (Q420). DC is fed to the final via a low pass filter with special low frequency decoupling. CV475 tunes the output matching across the entire band.

## 2.9 T857 Exciter Drive Amplifier

(Refer to Figure 2.2 and the exciter circuit diagram (sheet 3) in Section 6.3.)

A two-stage, wide band amplifier (Q304, Q305) provides an output level of approximately 1W (+30dBm) for an input of 100mW (+20dBm) from the VCO. IC300 pin 1, Q302, and Q303 provide a 9V regulated supply for the exciter.

To reduce the spurious output level when the synthesiser is out-of-lock, the Tx-Reg. and Lock-Detect signals are gated to inhibit the exciter control circuit and to switch off the RF signal at the input to the drive amplifier. This is achieved by a PIN switch attenuator (D201, D202, D203).

Cyclic keying control is provided by additional circuitry consisting of several time delay, ramp and gate stages:

- Q301, Q302, Q303, IC300                      power ramping
- Q310, Q311                                      Tx-Reg. and  $\overline{\text{Lock-Detect}}$  gate
- Q306, Q307, Q308, Q309                      delay and PIN switch drive.

This is to allow the RF power circuits (both exciter and PA) to ramp up and down in a controlled manner so that minimal adjacent channel interference is generated during the transition.

R517, R518 and R519 form a 3dB attenuator to provide good VCO/drive amplifier isolation as well as the correct exciter drive level

**Note:**            The exciter provides a DC control signal to the PA via the RF coax. This is injected via L314.



## 3 T856/857 Initial Tuning & Adjustment



**Caution:** This equipment contains CMOS devices which are susceptible to damage from static charges. Refer to Section 1.2 in Part A for more information on anti-static procedures when handling these devices.

The following section describes both short and full tuning and adjustment procedures and provides information on:

- channel programming
- selecting required audio links
- synthesiser alignment
- PA alignment (T856 only)
- modulator adjustment
- limiter adjustment
- setting line level
- compressor adjustment
- timer adjustment.

**Note:** Unless otherwise specified, the term "PGM800Win" used in this and following sections refers to version 2.00 and later of the software.

Refer to Figure 4.4 and Figure 4.5 which show the location of the main tuning and adjustment controls. Refer also to Section 6 where the parts lists, grid reference index and diagrams will provide detailed information on identifying and locating components and test points on the main PCB. The parts list and diagrams for the VCO PCB are in Part E.

Section	Title	Page
3.1	Introduction	3.3
3.2	Channel Programming	3.3
3.3	Test Equipment Required	3.4
3.4	Short Tuning Procedure	3.5
3.4.1	Introduction	3.5
3.4.2	Synthesiser Alignment	3.5
3.4.3	Output Power Adjustment (T856 Only)	3.5
3.4.4	Two Point Modulation Adjustment	3.6
3.4.5	FM Deviation (Limiter) Adjustment	3.6
3.4.6	Line-in Level Adjustment	3.7
3.4.7	CTCSS Encoder	3.7

Section	Title	Page
<b>3.5</b>	<b>Audio Processor Links</b>	<b>3.8</b>
3.5.1	Link Details	3.8
3.5.2	Typical Options	3.8
<b>3.6</b>	<b>Synthesiser Alignment</b>	<b>3.9</b>
<b>3.7</b>	<b>PA Alignment (T856 Only)</b>	<b>3.10</b>
<b>3.8</b>	<b>Thermal Shutdown (T856 Only)</b>	<b>3.10</b>
<b>3.9</b>	<b>Audio Processor</b>	<b>3.11</b>
3.9.1	Two Point Modulation	3.11
3.9.2	Modulator Adjustment	3.11
3.9.3	Limiter Adjustment	3.12
3.9.4	Line Level Without Compressor	3.12
3.9.5	Compressor	3.12
3.9.5.1	Compressor On Line Input Only	3.12
3.9.5.2	Compressor On Microphone Input Only	3.13
3.9.5.3	Compressor On Both Line & Microphone Inputs	3.13
<b>3.10</b>	<b>CTCSS Encoder</b>	<b>3.14</b>

Figure	Title	Page
3.1	T856/857 Test Equipment Set-up With T800-01-0010	3.4
3.2	T856/857 Test Equipment Set-up Without T800-01-0010	3.4



## 3.1 Introduction

When you receive your T856 transmitter or T857 exciter it will be run up and working on a particular frequency (the "default channel")<sup>1</sup>. If you want to switch to a frequency that is within the 8MHz switching range (i.e.  $\pm 4$ MHz from the factory programmed frequency), you should only need to reprogram the transmitter/exciter with the PGM800Win software (refer to the PGM800Win programming kit and Section 3.2 below).

However, if you want to switch to a frequency outside the 8MHz switching range, you will have to reprogram and re-tune the transmitter/exciter to ensure correct operation. In this case you should carry out the short tuning procedure described in Section 3.4.

If you have carried out repairs or other major adjustments, you must carry out the full tuning and adjustment procedure described in this section (except for Section 3.4).

## 3.2 Channel Programming

You can program up to 128 channel frequencies into the transmitter/exciter's EEPROM memory (IC820) by using the PGM800Win software package and an IBM™ PC. You can also use PGM800Win to select the transmitter/exciter's current operating frequency (or "default channel").

If the transmitter/exciter is installed in a rack frame, you can program it via the programming port in the speaker panel. However, you can also program the transmitter/exciter before it is installed in a rack frame as follows:

- by using a T800-01-0010 calibration test unit;
- via D-range 1;
- via D-range 2 (standard T800-03-0000 auxiliary D-range only);
- via SK805 (internal Micromatch connector).

If you do not use the T800-01-0010, you will have to connect the PC to the transmitter/exciter via a module programming interface (such as the T800-01-0004).

For a full description of the channel programming procedure, refer to the PGM800Win programming software user's manual.

**Note:** When an auxiliary D-range kit (D-range 2 - T800-03-0000) is fitted, you can also select a channel with an external switch, such as the DIP switch on the rack frame backplane PCB. Refer to Part C in the T800 Series Ancillary Equipment Service Manual (M800-00-101 or later issue) or consult your nearest Tait Dealer or Customer Service Organisation for further details.

---

1. Use the "Read Module" function in PGM800Win to find out what the default channel is.

### 3.3 Test Equipment Required

You will need the following test equipment:

- computer with PGM800Win installed
  - T800 programming kit
  - module programming interface (e.g. T800-01-0004 - optional)
  - 13.8V power supply
  - digital multimeter
  - audio signal generator
  - RF power meter
  - audio voltmeter x 2
  - modulation meter
  - oscilloscope (digital preferred)
  - 20dB or 40dB pad
  - T800-01-0010 calibration test unit (optional)
- } or RF test set (optional)

Figure 3.1 and Figure 3.2 show typical test equipment set-ups.

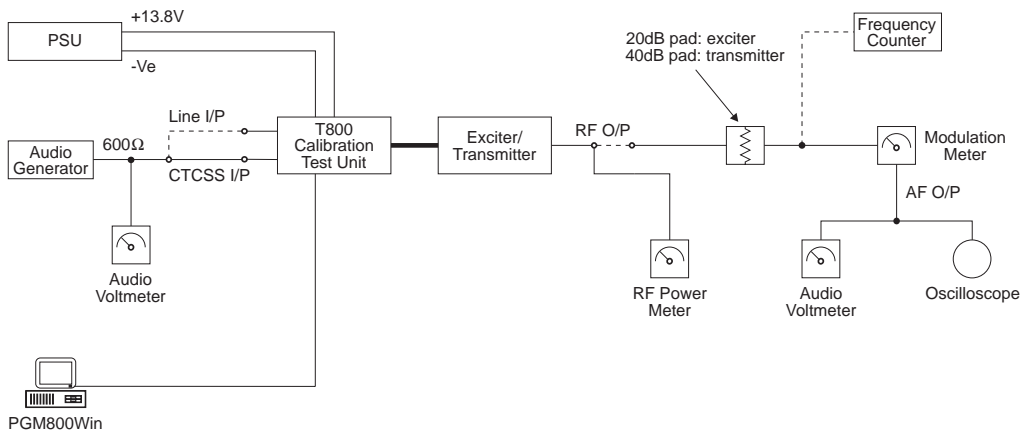

Figure 3.1 T856/857 Test Equipment Set-up With T800-01-0010

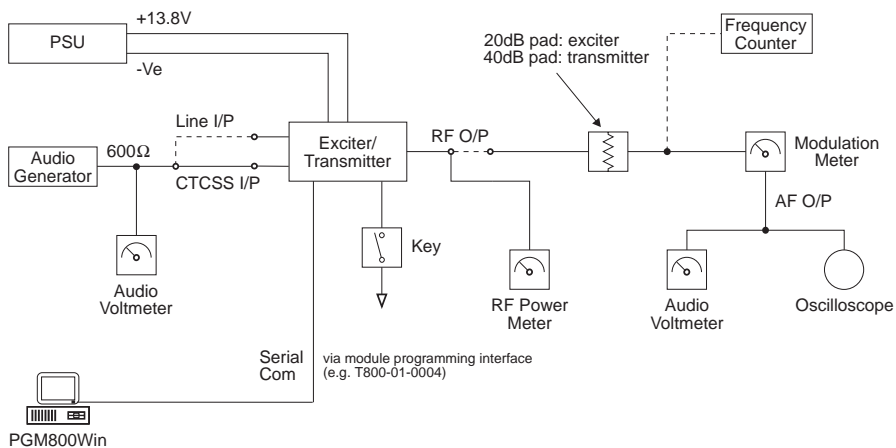

Figure 3.2 T856/857 Test Equipment Set-up Without T800-01-0010

## 3.4 Short Tuning Procedure

Use this procedure only if you want to reprogram the T856/857 to a frequency outside the 8MHz switching range and do not intend to carry out any other major adjustments or repairs.

### 3.4.1 Introduction

Reprogram the operating frequency as described in the PGM800Win programming kit (refer to Section 3.2).

Remove the top cover (nearest the handle).

Set up the test equipment as described in Section 3.3.

Set the links in the audio processor section as required (refer to Section 3.5).

### 3.4.2 Synthesiser Alignment

- Connect a high impedance voltmeter to the long lead of L1 in the VCO (this measures the synthesiser loop voltage).
- Key the transmitter by earthing the Tx-Key line.
- **Single Channel** Tune VCO trimmer C6 for a synthesiser loop voltage of 10V.
- **Multichannel** Tune VCO trimmer C6 for a synthesiser loop voltage of 10V on the middle channel.  
If there is no middle channel, tune C6 so that the channels are symmetrically placed around a loop voltage of 10V.  
All channels should lie within the upper and lower limits of 16V and 3V respectively.  
Do not attempt to program channels with a greater frequency separation than the specified switching range of 8MHz.

### 3.4.3 Output Power Adjustment (T856 Only)

Connect an RF power meter to the output socket and key the transmitter.

Turn RV310 (power control) fully clockwise.

Tune #CV475 (output power trim) for maximum output power and check that this is >30W.

Adjust RV310 for the required output power (between 5 and 25W).

Readjust #CV475 to reduce the supply current by up to 0.5A.

### 3.4.4 Two Point Modulation Adjustment

**Note 1:** In this and following sections deviation settings are given first for wide bandwidth sets, followed by settings in brackets for mid bandwidth sets ( ) and narrow bandwidth sets [ ].

**Note 2:** Reference modulation and limiter adjustment are controlled by PGM800Win. Electronic potentiometers (256 step) are used to allow channel-by-channel adjustment of deviation and two point modulation.

**Note 3:** To optimise the modulation response across the switching range, repeat steps 1-4 below for each channel that will be used (usually needed only for data applications). In applications where the modulation response is less critical (e.g. voice use only), carry out steps 1-4 below on the middle channel and cut and paste the value to all other channels.

1. Inject an audio signal of 300Hz 1.5V rms (+5dBm) into the CTCSS input (D-range 1 (PL100) pin 8).

Key the transmitter by earthing the Tx-Key line.

2. Adjust the output from the audio generator to obtain  $\pm 3\text{kHz}$  ( $\pm 2.4\text{kHz}$ ) [ $\pm 1.5\text{kHz}$ ] deviation at 300Hz.

3. Change the input frequency to 100Hz and adjust IC220 via PGM800Win "reference modulation" to obtain  $\pm 3\text{kHz}$  ( $\pm 2.4\text{kHz}$ ) [ $\pm 1.5\text{kHz}$ ] deviation (you can use either the mouse or up and down arrow keys).

4. Change the input frequency back to 300Hz.

Repeat steps 2 and 3 above until the deviations achieved at the two input frequencies are within 0.2dB of each other. You will need to do this at least four times.

5. Sweep the audio between 50 and 300Hz for peaks.

**Note:** A peak between 50 and 300Hz will indicate a fault condition, i.e:

- incorrect set-up
- or - modulation circuitry fault.

The specification window is  $\pm 1\text{dB}$  relative to 150Hz from 67 to 260Hz.

### 3.4.5 FM Deviation (Limiter) Adjustment

**Note:** If the T856/857 will be used over the whole 8MHz switching range, you must set the deviation for each channel. However, if the module will be used on frequencies that cover only a 1MHz (or less) switching range, you can set the deviation on the middle channel and use this value for all other channels with the "fill" option in PGM800Win.

Inject 1kHz at -10dBm into the line input (D-range 1 (PL100) pins 1 & 4; pins 2 & 3 shorted; refer to Section 2.2 of Part F).

Adjust RV210 (line sensitivity) fully clockwise and key the transmitter by earthing the Tx-Key line. Adjust IC220 via PGM800Win "deviation" to set the peak deviation to  $\pm 4.7\text{kHz}$  ( $\pm 3.8\text{kHz}$ ) [ $\pm 2.3\text{kHz}$ ] (you can use either the mouse or up and down arrow keys).

Sweep the audio frequency from 100Hz to 4kHz and ensure that the maximum deviation does not exceed  $\pm 4.7\text{kHz}$  ( $\pm 3.8\text{kHz}$ ) [ $\pm 2.3\text{kHz}$ ]. Readjust IC220 if necessary via PGM800Win "deviation".

### 3.4.6 Line-in Level Adjustment

Set the injected signal at the line input to the required line level (typically -10 to -20dBm).

Adjust RV210 (line sensitivity) to provide  $\pm 3\text{kHz}$  ( $\pm 2.4\text{kHz}$ ) [ $\pm 1.5\text{kHz}$ ] deviation.

### 3.4.7 CTCSS Encoder

Program a CTCSS tone on the set channel using PGM800Win.

Key the T856/857 with the front panel "Carrier" switch.

Adjust RV805 (CTCSS level adjust) to give 10% system deviation.

Reset the maximum deviation as per Section 3.4.5.

## 3.5 Audio Processor Links

### 3.5.1 Link Details

Use the following table to set up the audio processor to the configuration you require. You should set the audio processor links before carrying out any of the tuning and adjustment procedures. The factory settings are shown in brackets [ ].

Plug	Link <sup>a</sup>	Function
PL205	1-2 A	not connected
	[3-4] B	microphone pre-amp. output to compressor input
	5-6 C	microphone pre-amp. output to multiplexer input
PL210	[1-2] L	multiplexer output to pre-emphasis input
	3-4 M	multiplexer output to limiter input
	5-6 N	multiplexer output to compressor input
PL215	1-2 G	not connected
	[3-4] H	compressor output to multiplexer input
	5-6 I	compressor output to limiter input
	7-8 J	compressor output to pre-emphasis input
	9-10 K	not connected
PL220	1-2 D	pre-emphasis output to multiplexer input
	[3-4] E	pre-emphasis output to limiter input
	5-6 F	not connected

- a. The letters in this column and in the table in Section 3.5.2 below refer to the identification letters screen printed onto the PCB beside each pair of pins.

### 3.5.2 Typical Options

	PL205	PL210	PL215	PL220
microphone pre-amp. compressed and pre-emphasised; line input pre-emphasised (standard set-up)	[3-4] B	[1-2] L	[3-4] H	[3-4] E
microphone pre-amp. compressed and pre-emphasised; line input unprocessed	3-4 B	3-4 M	7-8 J	1-2 D
line and microphone compressed and pre-emphasised	5-6 C	5-6 N	7-8 J	3-4 E
microphone pre-amp. compressed; line and microphone flat response	3-4 B	3-4 M	3-4 H	5-6 F

## 3.6 Synthesiser Alignment

- Ensure that the T856/857 has been programmed with the required frequencies using PGM800Win software.
- **Single Channel**      Select a channel using PGM800Win.  
**Multichannel**      Select the middle channel via PGM800Win.
- Connect a high impedance voltmeter to the long lead of L1 in the VCO (this measures the synthesiser loop voltage).
- Key the transmitter by earthing the Tx-Key line.  
**Single Channel**      Tune VCO trimmer C6 for a synthesiser loop voltage of 10V.  
**Multichannel**      Tune VCO trimmer C6 for a synthesiser loop voltage of 10V on the middle channel.  
  
If there is no middle channel, tune C6 so that the channels are symmetrically placed around a loop voltage of 10V.  
  
All channels should lie within the upper and lower limits of 16V and 3V respectively.  
  
Do not attempt to program channels with a greater frequency separation than the specified switching range (8MHz).
- Check that the exciter output power is 1W  $\pm$ 300mW (**T857 only**).
- Measure the exciter output frequency and adjust the TCXO (=IC700) trimmer if required.



**Caution:** This trimmer is susceptible to physical damage. Do not exert a downward force of more than 500g (1lb) when adjusting.

## 3.7 PA Alignment (T856 Only)

Check that the exciter is connected to the PA with the coaxial link.

Connect an RF power meter to the PA output (use an appropriate attenuator as necessary).

Turn RV310 (power control) fully clockwise.

**Note:** Before the following measurement is taken, ensure the heatsink is at ambient temperature (20-25°C).

Measure and record the voltage (VL) at L481; perform this measurement at room temperature so that the NTC (R481) is close to 25°C.

Key the transmitter by earthing the Tx-Key line.

Tune #CV475 until maximum power is obtained. Check that the power exceeds 30W.

Adjust RV310 (power control) to 25W.

Readjust #CV475 to reduce the supply current by up to 0.5A.

## 3.8 Thermal Shutdown (T856 Only)

Key the transmitter by earthing the Tx-Key line and set the output power to 25W as described in Section 3.7.

Short L481 to ground.

Set RV330 (shutdown power level) for an output power of 5W.

Set RV320 (shutdown temperature) to 0.16VL volts (measured at IC350 pin 3), where VL is the voltage measured at L481 in Section 3.7. This sets the thermal shutdown at 85°C at NTC R481.



## 3.9 Audio Processor

### 3.9.1 Two Point Modulation

The T856 and T857 utilise two point modulation to obtain a wide audio bandwidth independent of the synthesiser loop filter response. This is achieved by simultaneously frequency modulating the VCO and phase modulating the synthesiser reference frequency. The relative signal levels fed to the two modulators are quite critical and cause interaction when setting up.

Both modulating signals require readjustment when the exciter is shifted in frequency greater than the switching range (i.e.  $\Delta F > \pm 4\text{MHz}$ ).

**Note 1:** In this and following sections deviation settings are given first for wide bandwidth sets, followed by settings in brackets for mid bandwidth sets ( ) and narrow bandwidth sets [ ].

**Note 2:** Reference modulation and limiter adjustment are controlled by PGM800Win. Electronic potentiometers (256 step) are used to allow channel-by-channel adjustment of deviation and two point modulation.

**Note 3:** To optimise the modulation response across the switching range, repeat steps 1-4 below for each channel that will be used (usually needed only for data applications). In applications where the modulation response is less critical (e.g. voice use only), carry out steps 1-4 below on the middle channel and cut and paste the value to all other channels.

### 3.9.2 Modulator Adjustment

1. Inject an audio signal of 300Hz 1.5V rms (+5dBm) into the CTCSS input (D-range 1 (PL100) pin 8).  
Key the transmitter by earthing the Tx-Key line.
2. Adjust the output from the audio generator to obtain  $\pm 3\text{kHz}$  ( $\pm 2.4\text{kHz}$ ) [ $\pm 1.5\text{kHz}$ ] deviation at 300Hz.
3. Change the input frequency to 100Hz and adjust IC220 via PGM800Win "reference modulation" to obtain  $\pm 3\text{kHz}$  ( $\pm 2.4\text{kHz}$ ) [ $\pm 1.5\text{kHz}$ ] deviation.
4. Change the input frequency back to 300Hz.  
Repeat steps 2 and 3 above until the deviations achieved at the two input frequencies are within 0.2dB of each other. You will need to do this at least four times.
5. Sweep the audio between 50 and 300Hz for peaks.

**Note:** A peak between 50 and 300Hz will indicate a fault condition, i.e:  
- incorrect set-up  
or - modulation circuitry fault.

The specification window is  $\pm 1\text{dB}$  relative to 150Hz from 67 to 260Hz.

### 3.9.3 Limiter Adjustment

**Note:** If the T856/857 will be used over the whole 8MHz switching range, you must set the deviation for each channel. However, if the module will be used on frequencies that cover only a 1MHz (or less) switching range, you can set the deviation on the middle channel and use this value for all other channels with the “fill” option in PGM800Win.

Set the links in the audio processor section as required (refer to Section 3.5).

Inject 1kHz at -10dBm into the line input (D-range 1 (PL100) pins 1 & 4; and pins 2 & 3 shorted; refer to Section 2.2 of Part F).

Adjust RV210 (line sensitivity) fully clockwise and key the transmitter by earthing the Tx-Key line. Adjust IC220 via PGM800Win “deviation” to set the peak deviation to  $\pm 4.7\text{kHz}$  ( $\pm 3.8\text{kHz}$ ) [ $\pm 2.3\text{kHz}$ ] (you can use either the mouse or up and down arrow keys).

Sweep the audio frequency from 100Hz to 4kHz and ensure that the maximum deviation does not exceed  $\pm 4.7\text{kHz}$  ( $\pm 3.8\text{kHz}$ ) [ $\pm 2.3\text{kHz}$ ]. Readjust IC220 if necessary via PGM800Win “deviation”.

### 3.9.4 Line Level Without Compressor

This section assumes that the compressor is not used. If the compressor is required, refer to Section 3.9.5.

Adjust the line sensitivity as follows:

- set the injected signal at the line input to the required line level (typically -10 to -20dBm);
- adjust RV210 (line sensitivity) to provide  $\pm 3\text{kHz}$  ( $\pm 2.4\text{kHz}$ ) [ $\pm 1.5\text{kHz}$ ] deviation.

### 3.9.5 Compressor

The compressor may be used on the line input only, the microphone input only, or on both the line and microphone inputs. If the compressor is used, refer to one of the following sections as appropriate.

#### 3.9.5.1 Compressor On Line Input Only

Set RV210 (line sensitivity) fully clockwise and key the transmitter by earthing the Tx-Key line.

Reduce the line level to -50dBm at 1kHz and set RV220 (compression level) fully clockwise.

Check that  $\pm 3\text{kHz}$  deviation ( $\pm 2.4\text{kHz}$ ) [ $\pm 1.5\text{kHz}$ ] is still available.

Slowly increase the audio input level until the demodulated waveform shows significant signs of clipping (approximately  $\pm 4.5\text{kHz}$  ( $\pm 3.6\text{kHz}$ ) [ $\pm 2.3\text{kHz}$ ] deviation).

Adjust RV220 anticlockwise until the demodulated waveform is just clipping (approximately  $\pm 4\text{kHz}$  ( $\pm 3.2\text{kHz}$ ) [ $\pm 2\text{kHz}$ ] deviation).

Increase the input level to  $-10\text{dBm}$  and check that the test tone is still held just into clipping. The input line level should be typically  $-10$  to  $-20\text{dBm}$ .

### 3.9.5.2 Compressor On Microphone Input Only

Key the transmitter by earthing the Tx-Key line and plug a microphone jack into the front panel socket.

Adjust RV220 (compression level) fully clockwise.

Acoustically couple the microphone to a tone box ( $1\text{kHz}$ ) and close the PTT switch.

Increase the audio level until the demodulated waveform shows significant signs of clipping (approximately  $\pm 4.5\text{kHz}$  ( $\pm 3.6\text{kHz}$ ) [ $\pm 2.3\text{kHz}$ ] deviation).

Adjust RV220 anticlockwise until the demodulated waveform is just clipping (approximately  $\pm 4\text{kHz}$  ( $\pm 3.2\text{kHz}$ ) [ $\pm 2\text{kHz}$ ] deviation).

Increase the audio level by  $10\text{dB}$  and verify that the test tone is held just into clipping.

Whistle steadily into the microphone, checking that approximately  $\pm 4\text{kHz}$  ( $\pm 3.2\text{kHz}$ ) [ $\pm 2\text{kHz}$ ] deviation is produced. The modulated waveform should be basically sinusoidal.

Speak into the microphone, checking that the modulation peaks reach about  $\pm 5\text{kHz}$  ( $\pm 4\text{kHz}$ ) [ $\pm 2.5\text{kHz}$ ] deviation.

As the line is to be used without compression, set RV210 (line sensitivity) as described in Section 3.9.4.

### 3.9.5.3 Compressor On Both Line & Microphone Inputs

Set up as described in Section 3.9.5.1.

## **3.10 CTCSS Encoder**

Program a CTCSS tone on the set channel using PGM800Win.

Key the T856/857 with the front panel "Carrier" switch.

Adjust RV805 (CTCSS level adjust) to give 10% system deviation.

Reset the maximum deviation as per Section 3.9.3.

## 4 T856/857 Functional Testing



**Caution:** This equipment contains CMOS devices which are susceptible to damage from static charges. Refer to Section 1.2 in Part A for more information on anti-static procedures when handling these devices.

The following test procedures will confirm that the T856/857 has been tuned and adjusted correctly and is fully operational.

**Note 1:** In this and following sections deviation settings are given first for wide bandwidth sets, followed by settings in brackets for mid bandwidth sets ( ) and narrow bandwidth sets [ ].

**Note 2:** Unless otherwise specified, the term "PGM800Win" used in this and following sections refers to version 2.00 and later of the software.

Refer to Figure 4.4 and Figure 4.5 for the location of the main tuning and adjustment controls, and to Section 3.3 for the test equipment set-up. Refer also to Section 6 where the parts lists, grid reference index and diagrams will provide detailed information on identifying and locating components and test points on the main PCB. The parts list and diagrams for the VCO PCB are in Part E.

The following topics are covered in this section.

Section	Title	Page
4.1	Current Consumption	4.3
4.2	Output Power	4.3
4.3	Output Frequency	4.3
4.4	Timers	4.3
4.5	Frequency Response	4.4
4.6	Audio Level Input Sensitivity	4.7

Figure	Title	Page
4.1	T856/857 Transmit Timers	4.4
4.2	T856/857 Pre-emphasis Response	4.5
4.3	T856/857 Limiting Response	4.6
4.4	T856 Main Tuning & Adjustment Controls	4.9
4.5	T857 Main Tuning & Adjustment Controls	4.11



## 4.1 Current Consumption

Connect the T856/857 to a 13.8V power supply.

Connect an RF power meter to the T856/857 output socket.

Check that the current in the 13.8V power cable is less than 150mA.

Key the T856/857 by earthing the Tx-Key line (the carrier "On" LED should light).

**T856 Only:** Adjust RV310 (power control) to obtain 25W output power.

Check that the current is as follows:

T856	<5.5A
T857	<750mA.

## 4.2 Output Power

Connect an RF power meter with suitable attenuation to the T856/857 output socket.

Key the T856/857 by earthing the Tx-Key line.

Check that:

T856	the output power adjusts to $\geq 25\text{W}$ with RV310 (power control) turned fully clockwise
T857	the output power is $1\text{W} \pm 300\text{mW}$ .

## 4.3 Output Frequency

Connect the T856/857 output to a frequency counter via an attenuator pad:

T856	40dB pad
T857	20dB pad.

Measure the output frequency and, if necessary, adjust the TCXO (=IC700) to trim to the nominal frequency ( $\pm 100\text{Hz}$ ).

## 4.4 Timers

The transmit tail timer, transmit timeout timer and transmit lockout timer can all be set from PGM800Win. The fields for setting these are found on the system information page. These three timers operate as follows (refer also to Figure 4.1):

Timer	Function	Adjustment
Transmit Tail	Sets the tail time during which the transmitter stays keyed after the external key source has been removed.	0-5 seconds in 100ms steps
Transmit Timeout	Sets the maximum continuous transmission time. Once the timer has timed out, the transmitter must be keyed again, unless prevented by the transmit lockout timer.	0-300 seconds in 10 second steps
Transmit Lockout	Sets the period of time that must elapse after a timeout before the transmitter can re-transmit. Once the timer has timed out, the transmitter can be keyed again.	0-60 seconds in 10 second steps

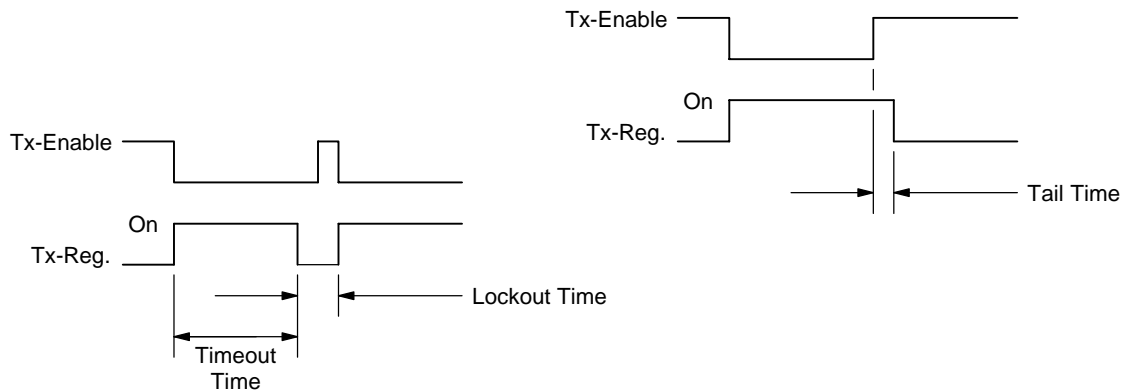

Figure 4.1 T856/857 Transmit Timers

## 4.5 Frequency Response

If the T856/857 has been correctly adjusted, the pre-emphasis and limiting responses should closely match those shown in Figure 4.2 and Figure 4.3 respectively.

**Note:** The limits shown on these graphs should not be exceeded.

- Measure the pre-emphasis response as follows:

  - Reduce the line level to give  $\pm 1\text{kHz}$  ( $\pm 0.8\text{kHz}$ ) [ $\pm 0.5\text{kHz}$ ] deviation at 1kHz.
  - Sweep the modulation frequency.
  - The response should closely match that shown in Figure 4.2.
- Measure the limiting response as follows:

  - Set the line level to give  $\pm 3\text{kHz}$  ( $\pm 2.4\text{kHz}$ ) [ $\pm 1.5\text{kHz}$ ] deviation at 1kHz.
  - Increase the line level 20dB and sweep the modulation frequency.
  - The response should closely match that shown in Figure 4.3.



### Wide Bandwidth

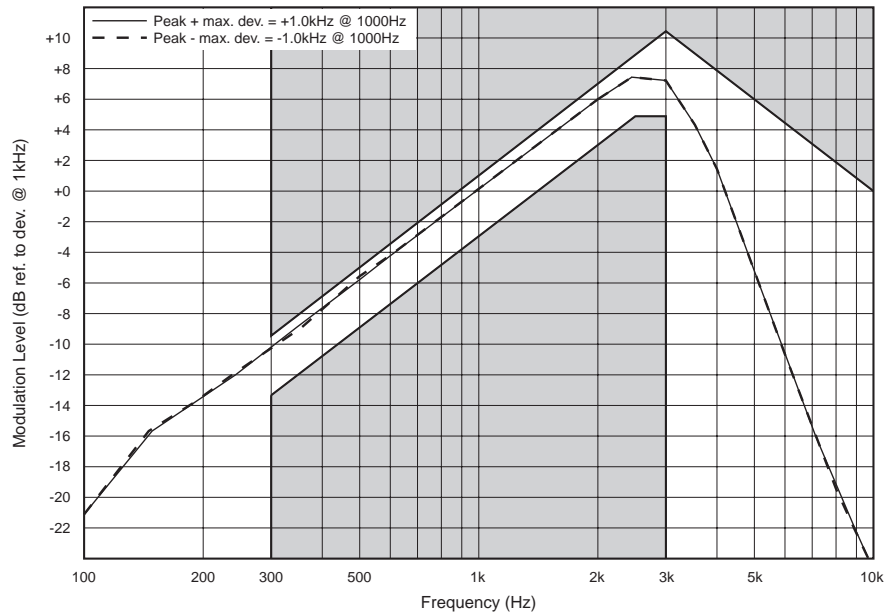

### Mid Bandwidth

The mid bandwidth graph is the same shape as the wide bandwidth graph. The deviation figures are as follows:

$$\begin{aligned} \text{peak + max. deviation} &= +0.8\text{kHz} \\ \text{peak - max. deviation} &= -0.8\text{kHz}. \end{aligned}$$

### Narrow Bandwidth

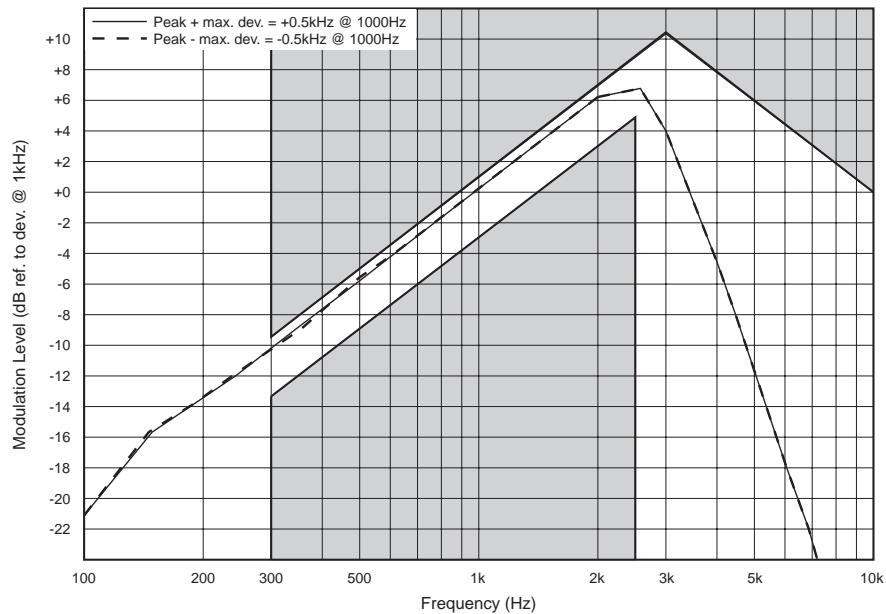
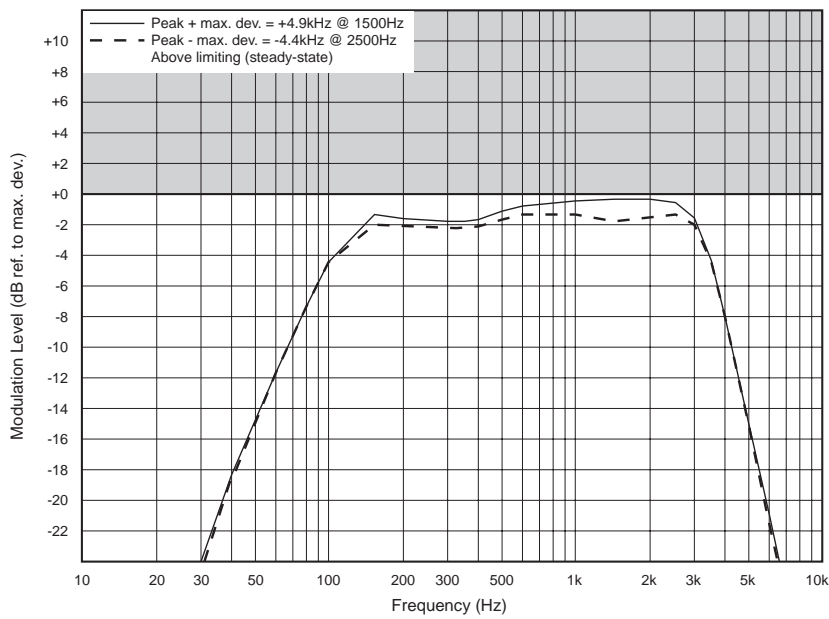

Figure 4.2 T856/857 Pre-emphasis Response

**Wide Bandwidth**



**Mid Bandwidth**

The mid bandwidth graph is the same shape as the wide bandwidth graph. The deviation figures are as follows:

- peak + max. deviation = +4kHz
- peak - max. deviation = -4kHz.

**Narrow Bandwidth**

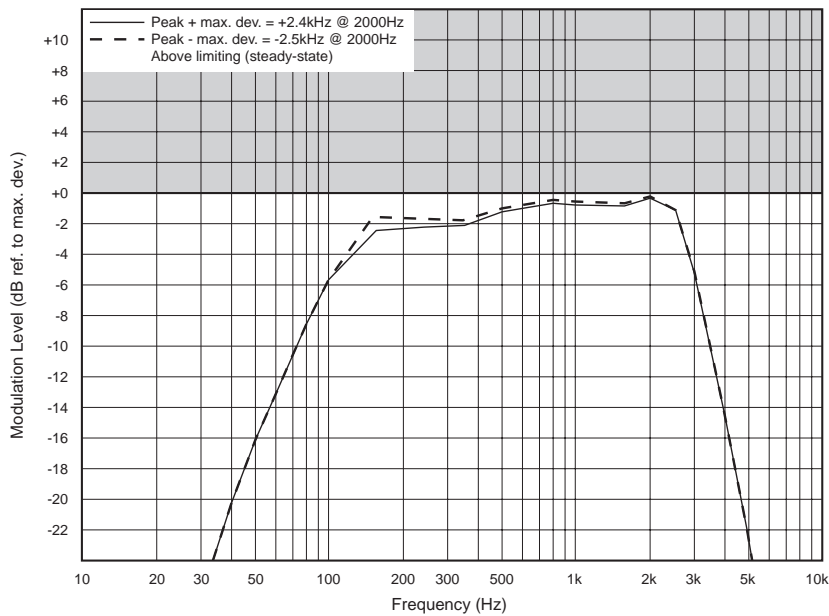

**Figure 4.3 T856/857 Limiting Response**

## 4.6 Audio Level Input Sensitivity

- Adjust RV210 (line sensitivity) fully clockwise.
- Check that the input sensitivities are better than those specified below:

Line Input	600 ohms, $\pm 3\text{kHz}$ ( $\pm 2.4\text{kHz}$ ) [ $\pm 1.5\text{kHz}$ ] deviation at 1kHz: with compressor -50dBm without compressor -30dBm
Microphone Input	600 ohms, $\pm 3\text{kHz}$ ( $\pm 2.4\text{kHz}$ ) [ $\pm 1.5\text{kHz}$ ] deviation at 1kHz: with compressor -75dBm without compressor -55dBm
CTCSS Input	1kHz deviation at 150Hz 500mV rms

**Note:** A degraded signal to noise ratio can be expected with the compressor selected. The extent of the degradation is dependent on the audio input level.



## 5 T856/857 Fault Finding



**Caution:** This equipment contains CMOS devices which are susceptible to damage from static charges. Refer to Section 1.2 in Part A for more information on anti-static procedures when handling these devices.

The following test procedures and fault finding flow charts may be used to help locate a hardware problem, however they are by no means a complete fault finding procedure. If you still cannot trace the fault after progressing through them in a logical manner, contact your nearest Tait Dealer or Customer Service Organisation. If necessary, you can get additional technical help from Customer Support, Radio Systems Division, Tait Electronics Ltd, Christchurch, New Zealand (full contact details are on page 2).

**Note 1:** In this and following sections deviation settings are given first for wide bandwidth sets, followed by settings in brackets for mid bandwidth sets ( ) and narrow bandwidth sets [ ].

**Note 2:** Unless otherwise specified, the term "PGM800Win" used in this and following sections refers to version 2.00 and later of the software.

Refer to Section 6 where the parts lists, grid reference index and diagrams will provide detailed information on identifying and locating components and test points on the main PCB. The parts list and diagrams for the VCO PCB are in Part E.

The following topics are covered in this section

Section	Title	Page
5.1	Visual Checks	5.3
5.2	Component Checks	5.3
5.3	Front Panel LED Indicator	5.3
5.4	DC Checks	5.4
5.4.1	Power Rails	5.4
5.4.2	VCO Locking	5.4
5.5	RF Checks	5.5
5.5.1	T856 Drive Power	5.5
5.5.2	T856 PA Output Power	5.5
5.5.3	T857 Output Power	5.5
5.5.4	Audio And Modulation	5.6
5.6	PGM800Win Generated Errors	5.7

Section	Title	Page
<b>5.7</b>	<b>Fault Finding Charts</b>	<b>5.8</b>
5.7.1	Microcontroller	5.8
5.7.1.1	Basic Checks	5.8
5.7.1.2	Serial Communications	5.9
5.7.1.3	CTCSS Encode	5.10
5.7.2	Regulator	5.11
5.7.3	Synthesiser	5.12
5.7.4	T856 Drive Amplifier	5.15
5.7.5	T856 PA & Power Control	5.16
5.7.6	T857 Exciter Drive Amplifier	5.17
5.7.7	Audio Processor	5.18
<b>5.8</b>	<b>To Replace The T856 PA Transistors (Q410 &amp; Q420)</b>	<b>5.19</b>

Figure	Title	Page
5.1	RF Diode Probe Circuit	5.5
5.2	Typical Transistor/Capacitor Spacing (Not To Scale)	5.19

## 5.1 Visual Checks

Remove the covers from the T856/857 and inspect the PCB for damaged or broken components, paying particular attention to the surface mounted devices (SMD's).

Check for defective solder joints. If repair or replacement is considered necessary, refer to Section 3 of Part A.

## 5.2 Component Checks

If you suspect a transistor is faulty, you can assess its performance by measuring the forward and reverse resistance of the junctions. Unless the device is completely desoldered, first make sure that the transistor is not shunted by some circuit resistance. Use a good quality EVM (e.g. Fluke 75) for taking the measurements (or a 20k ohm/V or better multimeter, using only the medium or low resistance ranges).

The collector current drawn by multi-junction transistors is a further guide to their performance.

If an IC is suspect, the most reliable check is to measure the DC operating voltages. Due to the catastrophic nature of most IC failures, the pin voltages will usually be markedly different from the recommended values in the presence of a fault. The recommended values can be obtained from either the circuit diagram or the component data catalogue.

## 5.3 Front Panel LED Indicator

The green "Supply" LED on the T856/857 front panel will flash according to the conditions described in the following table:

Flash Rate	Condition
<p style="text-align: center;">fast</p> <p style="text-align: center;">- - - - - (1/3 sec. on/1/3 sec. off approx.)</p>	T856/857 is linked with PGM800Win
<p style="text-align: center;">unequal</p> <p style="text-align: center;">- - - - - (1/3 sec. on/1 sec. off approx.)</p>	microcontroller has detected an internal communications error - refer to Section 5.7.1

Where two or more conditions occur at the same time, the precedence is in the order shown above (i.e. T856/857 linked has the highest priority, followed by internal error).

## 5.4 DC Checks

### 5.4.1 Power Rails

Refer to the test points and options diagrams in Section 6 for test point locations, and to the regulator fault finding chart (Section 5.7.2) for fault diagnosis.

Check the 13.8V (TP601) and 9V (TP602) supplies at their test points in the regulator compartment with a DMM.

Check the 5V (TP604) and 20V (TP603) rails at their respective test points in the regulator compartment.

Check that Tx-Reg. (TP305 in the exciter compartment) comes up to 8.8V when the exciter is keyed.

Check the +5V digital regulator output (TP607 in the regulator compartment).

**T856 Only:** Check the 9V supply (IC370 pin 1) with a DMM.

Check for short circuits.

### 5.4.2 VCO Locking

Key the exciter.

Using a DMM, monitor the VCO control voltage on the long lead of L1 on the VCO PCB.

If the synthesiser is locked and the VCO aligned, the voltage at this point should be between 3 and 16V.

If the VCO is not locked, refer to the synthesiser fault finding chart (Section 5.7.3).



## 5.5 RF Checks

In-circuit RF levels may be measured with an RF probe on which the earth lead has been shortened to a minimum (i.e. 13mm). Refer to the circuit diagrams for typical levels.

Figure 5.1 shows a suitable RF probe circuit..

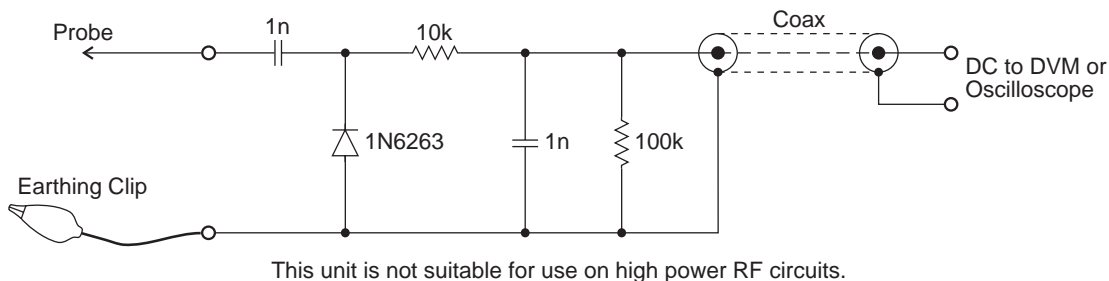

**Figure 5.1 RF Diode Probe Circuit**

### 5.5.1 T856 Drive Power

Refer to the drive amplifier fault finding chart (Section 5.7.4).

Ensure that the VCO locks (refer to Section 5.4.2).

Connect the drive output to a power meter and key the transmitter.

Check that the exciter output power (SK310) is >1.5W.

**Note:** If the synthesiser is out of lock, the lock detector (synthesiser IC740 and comparator IC750) will prevent the RF signal from reaching the PA by switching the supply to the exciter amplifier (Q350, Q355).

### 5.5.2 T856 PA Output Power

Reconnect the drive output to the PA input.

Connect the PA to a power meter and key the transmitter.

Check that the output power is >30W with RV310 (power control) adjusted fully clockwise.

### 5.5.3 T857 Output Power

Refer to the exciter drive amplifier fault finding chart (Section 5.7.6).

Ensure that the VCO locks (refer to Section 5.4.2).

Connect the exciter output to a power meter and key the exciter.

Check that the output power is  $1W \pm 300mW$ .

**Note:** If the synthesiser is out of lock, the lock detector (synthesiser IC740 and comparator IC750) will prevent the RF signal from reaching the PA by switching the supply to the exciter amplifier (Q301, IC300, Q302, Q303).

### 5.5.4 Audio And Modulation

Refer to the audio processor fault finding chart (Section 5.7.7).

Set up the audio processor as described in Section 3.9.

Check that the demodulated RF output has the frequency response referred to in Section 4.5 with at least  $\pm 5kHz$  ( $\pm 4kHz$ ) [ $\pm 2.5kHz$ ] deviation available at 1kHz modulating frequency.

If the above result is not achieved, either the two modulators are incorrectly adjusted or a fault condition exists.

## 5.6 PGM800Win Generated Errors

The following errors are those most likely to occur using PGM800Win. Refer to the PGM800Win software user's manual for a complete list of error messages.

### **Channel Switch Set**

The programmed default channel change was not accepted by the base station because a channel is selected externally. Try turning the external channel switch off to change the default channel in PGM800Win.

### **Synth Out Of Lock**

The synthesiser received incorrect data, or the data was corrupted. Enter a frequency within the VCO switching range, or tune the VCO.

### **Internal Error**

Data could not be read from the base station due to an internal error. Check for shorts or open circuits on the SDA, SCK, SYNTH and EPOT lines. The SDA, SCK and SYNTH are normally high, and the EPOT is normally low.

### **Write/Read To An Unlinked Module**

The link to the module does not exist. Undefined error.

## 5.7 Fault Finding Charts

**Note:** The standard test point designations used in this section are as follows:

TP601	13.8V
TP602	9V
TP603	20V
TP604	5V

### 5.7.1 Microcontroller (IC810)

#### 5.7.1.1 Basic Checks

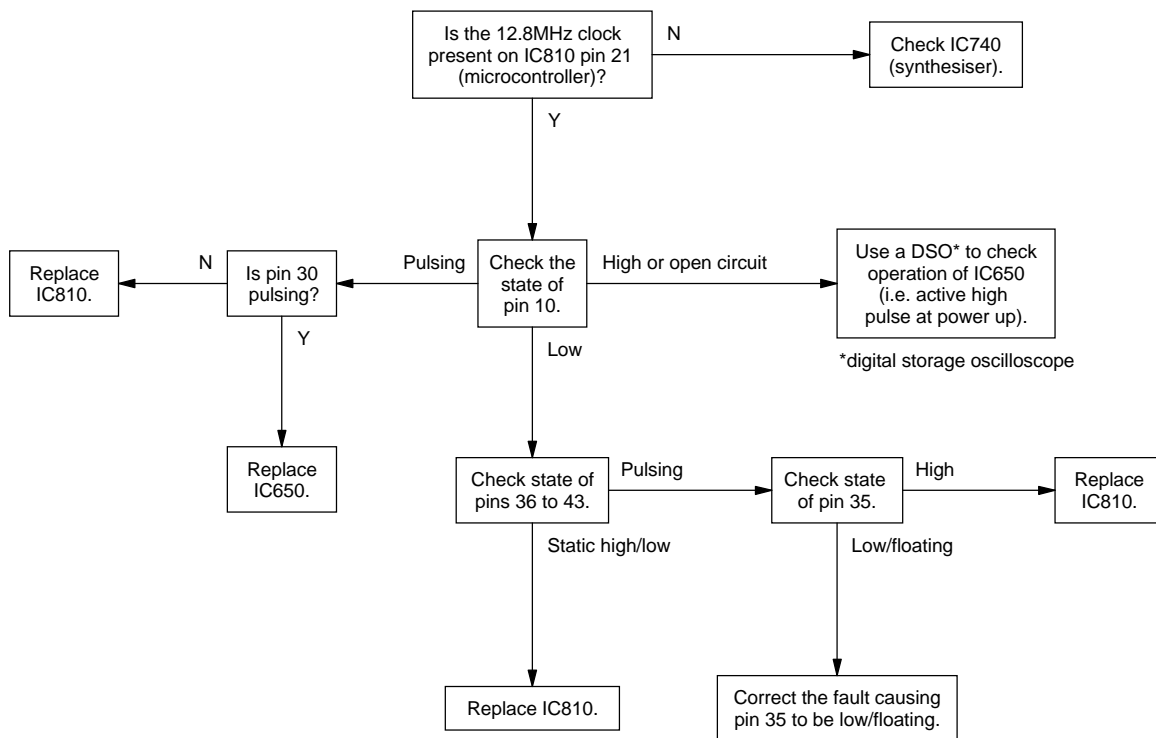

## 5.7.1.2 Serial Communication

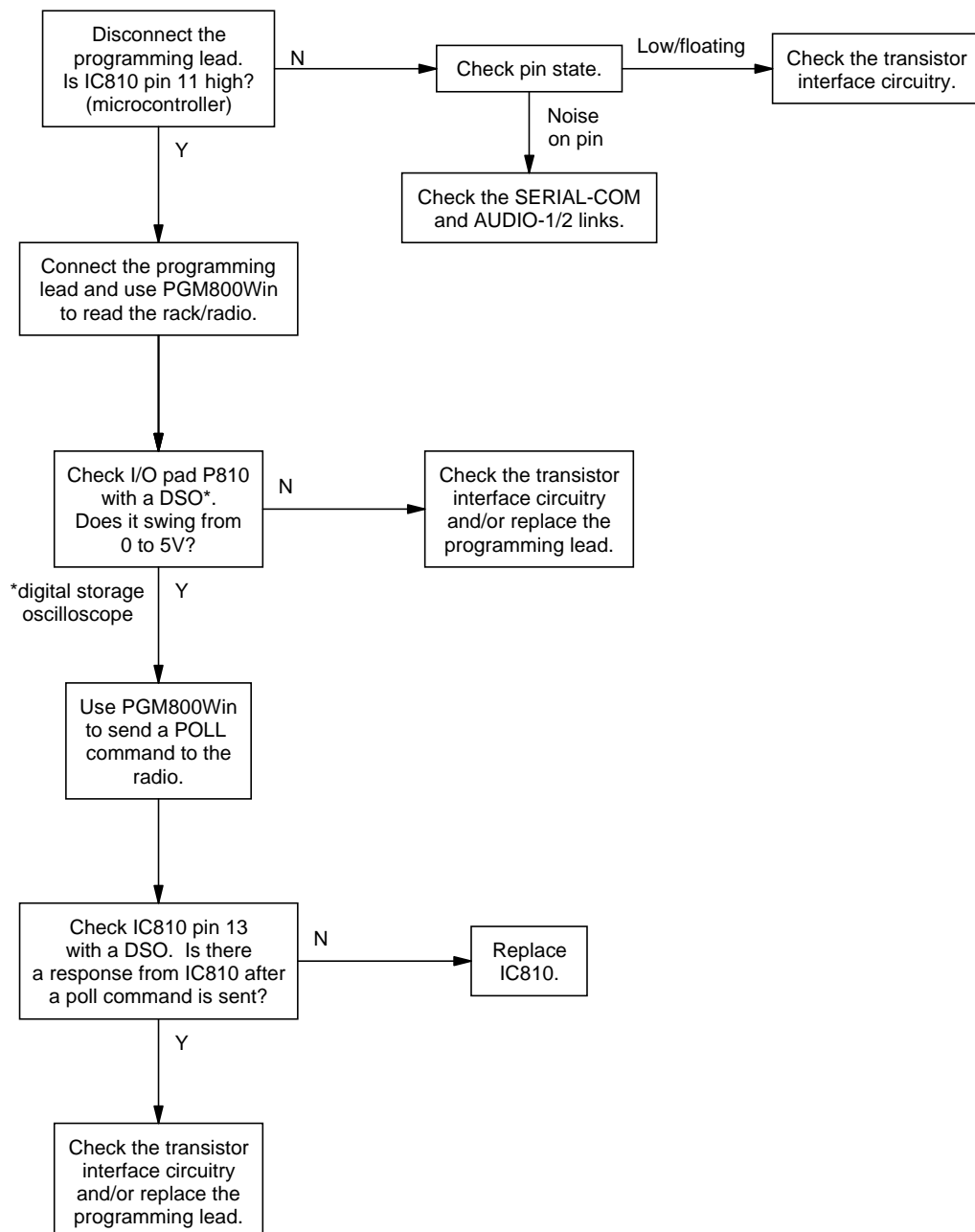

5.7.1.3 CTCSS Encode

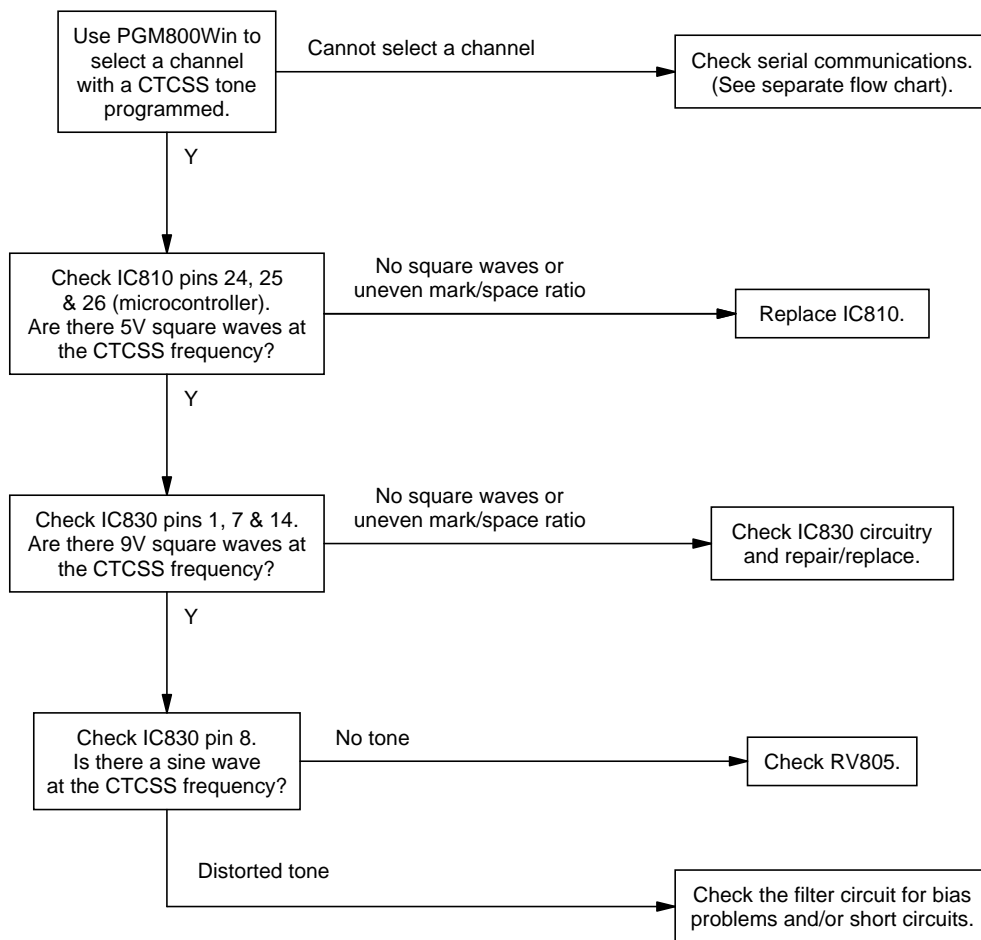

## 5.7.2 Regulator

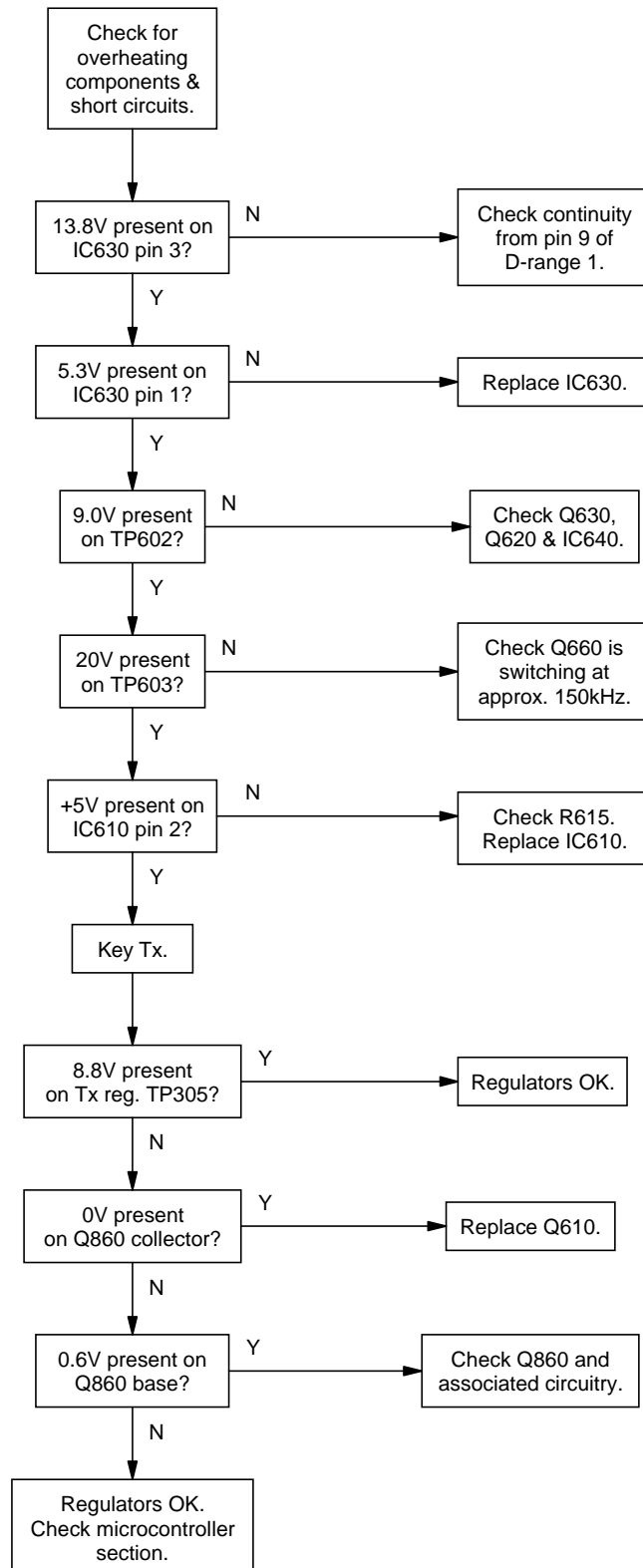

### 5.7.3 Synthesiser

Refer to the synthesiser circuit diagram (sheet 7) in Section 6 and the VCO circuit diagram in Part E.

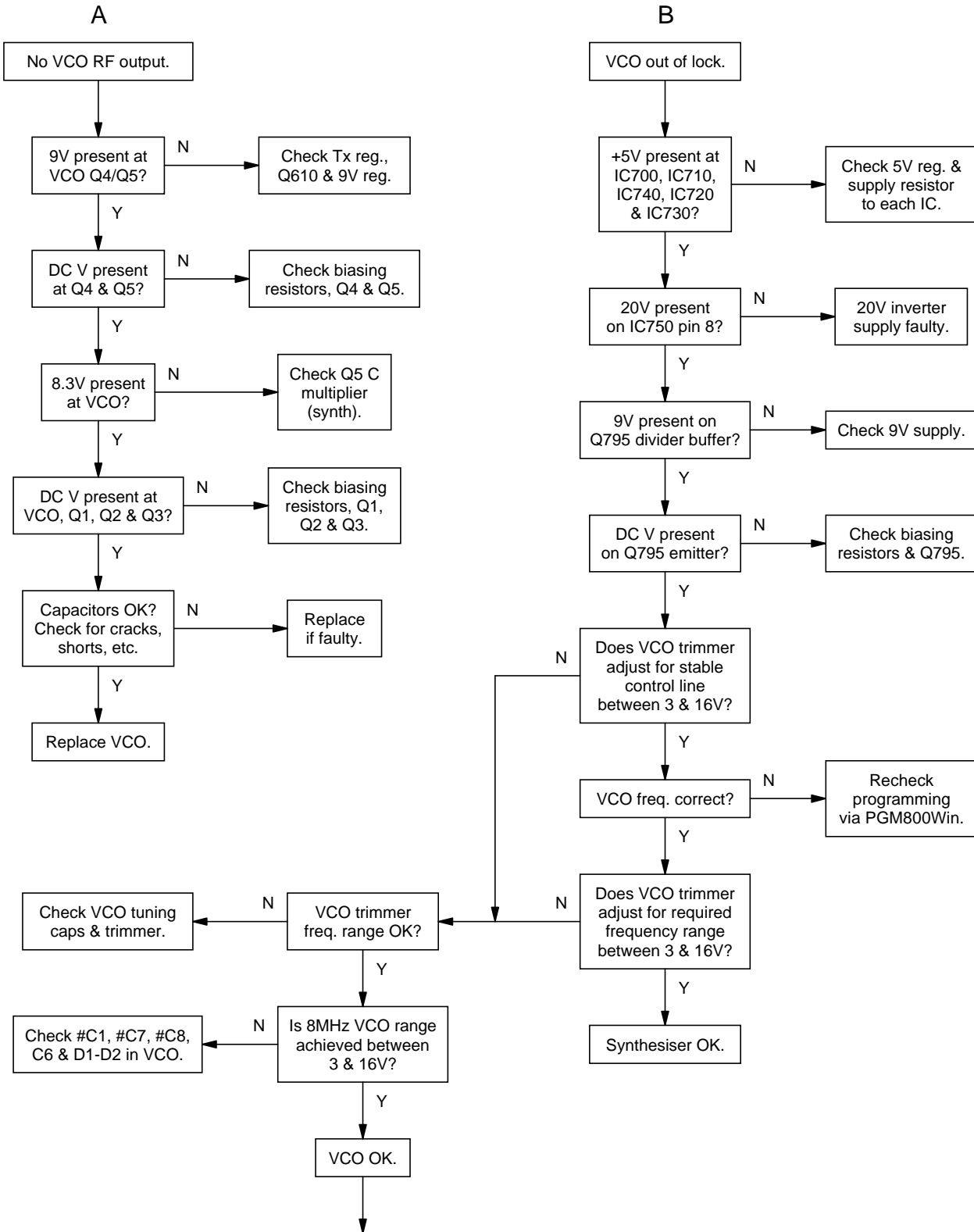

Continued on the next page



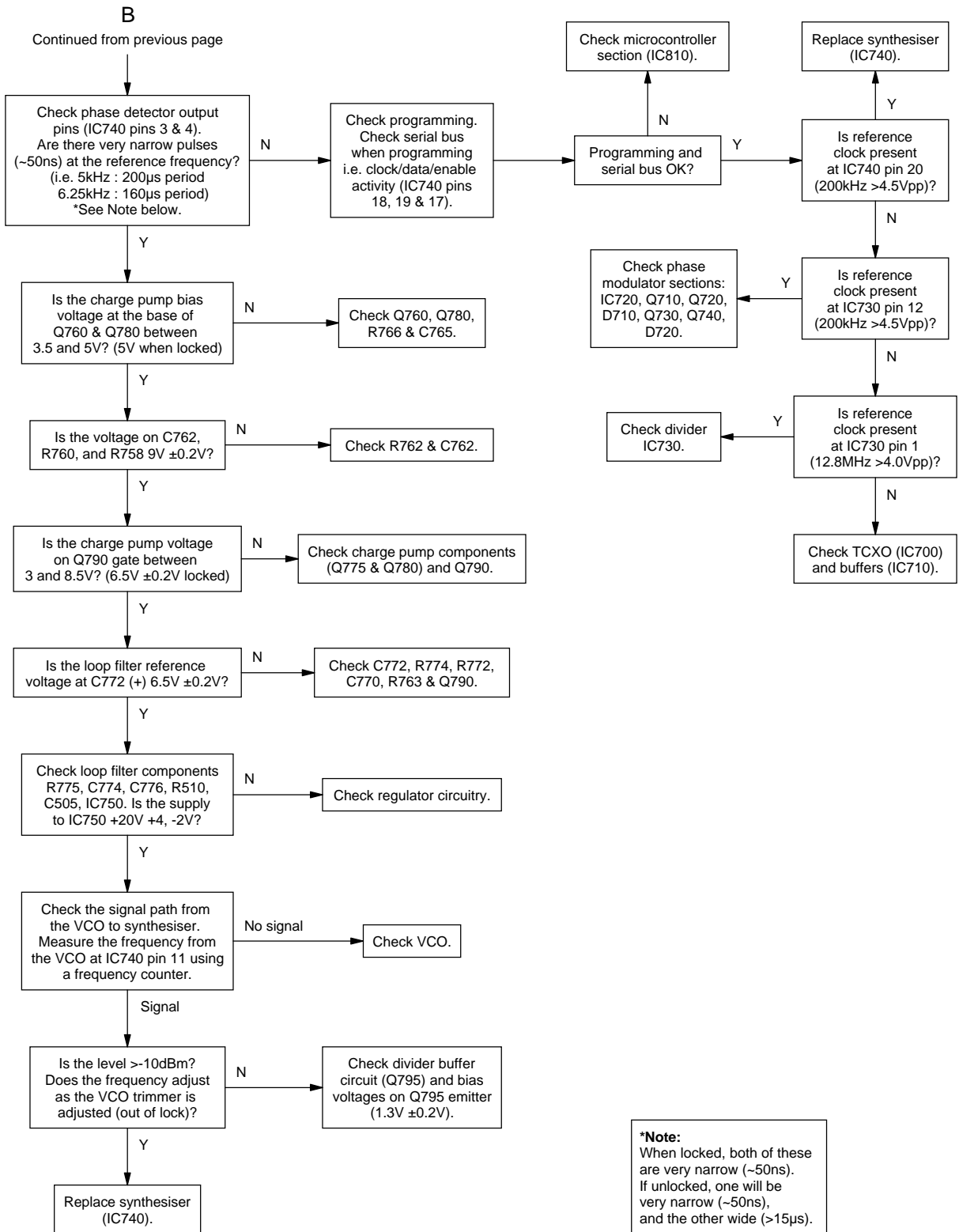

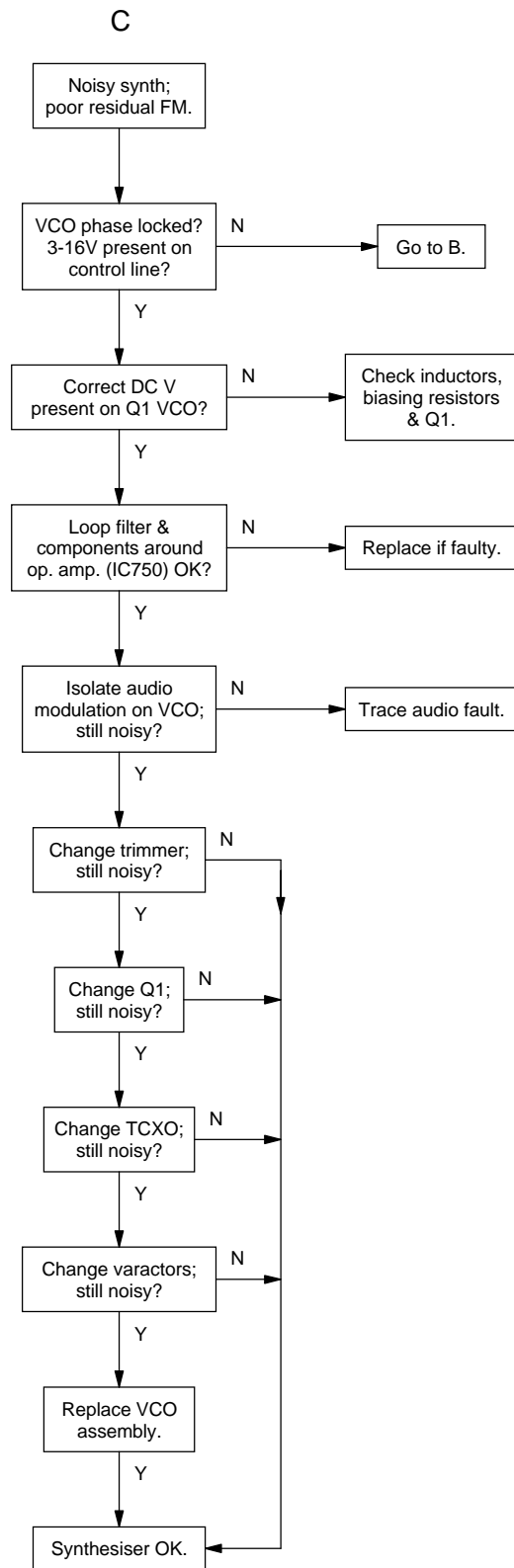

### 5.7.4 T856 Drive Amplifier

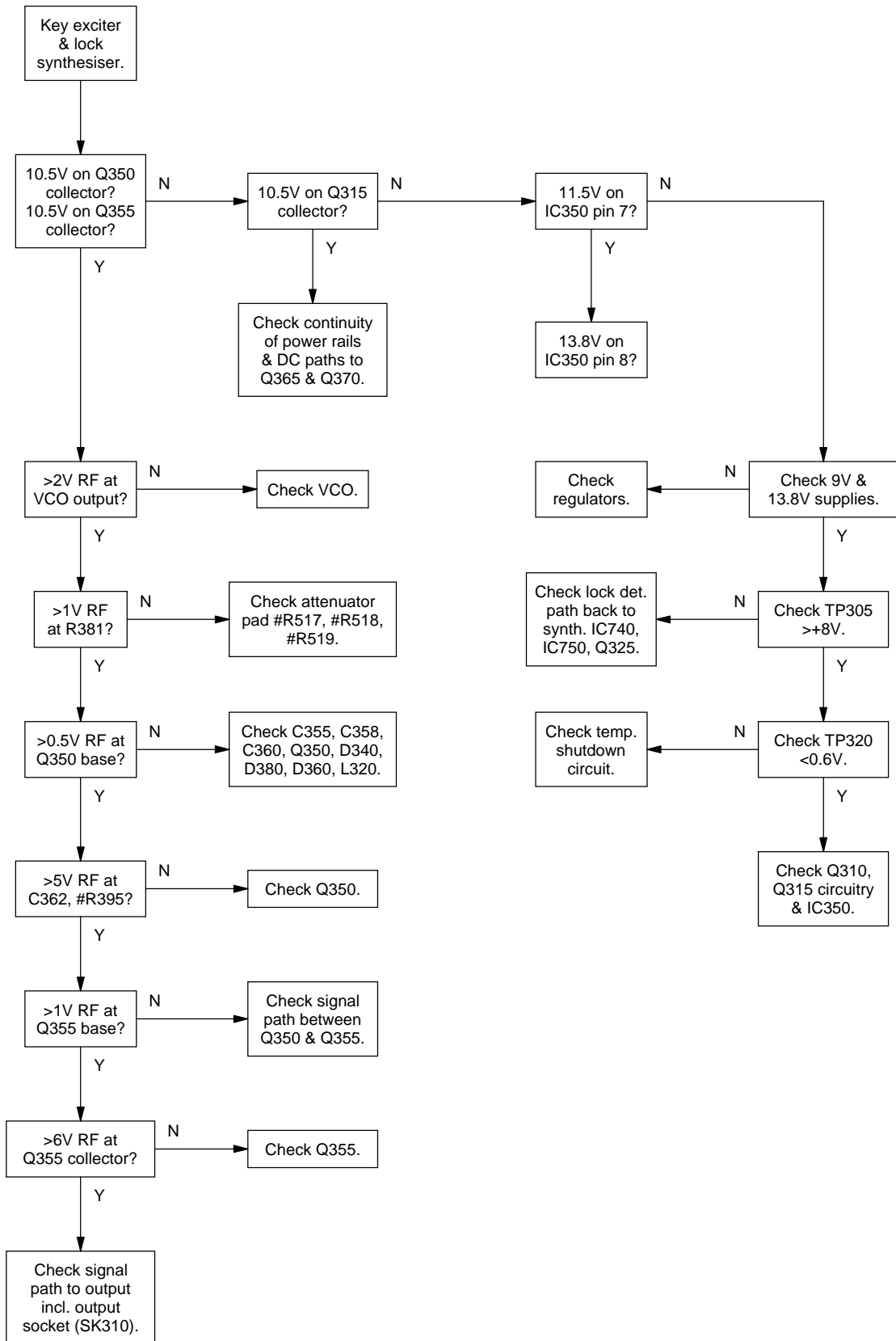

### 5.7.5 T856 PA & Power Control

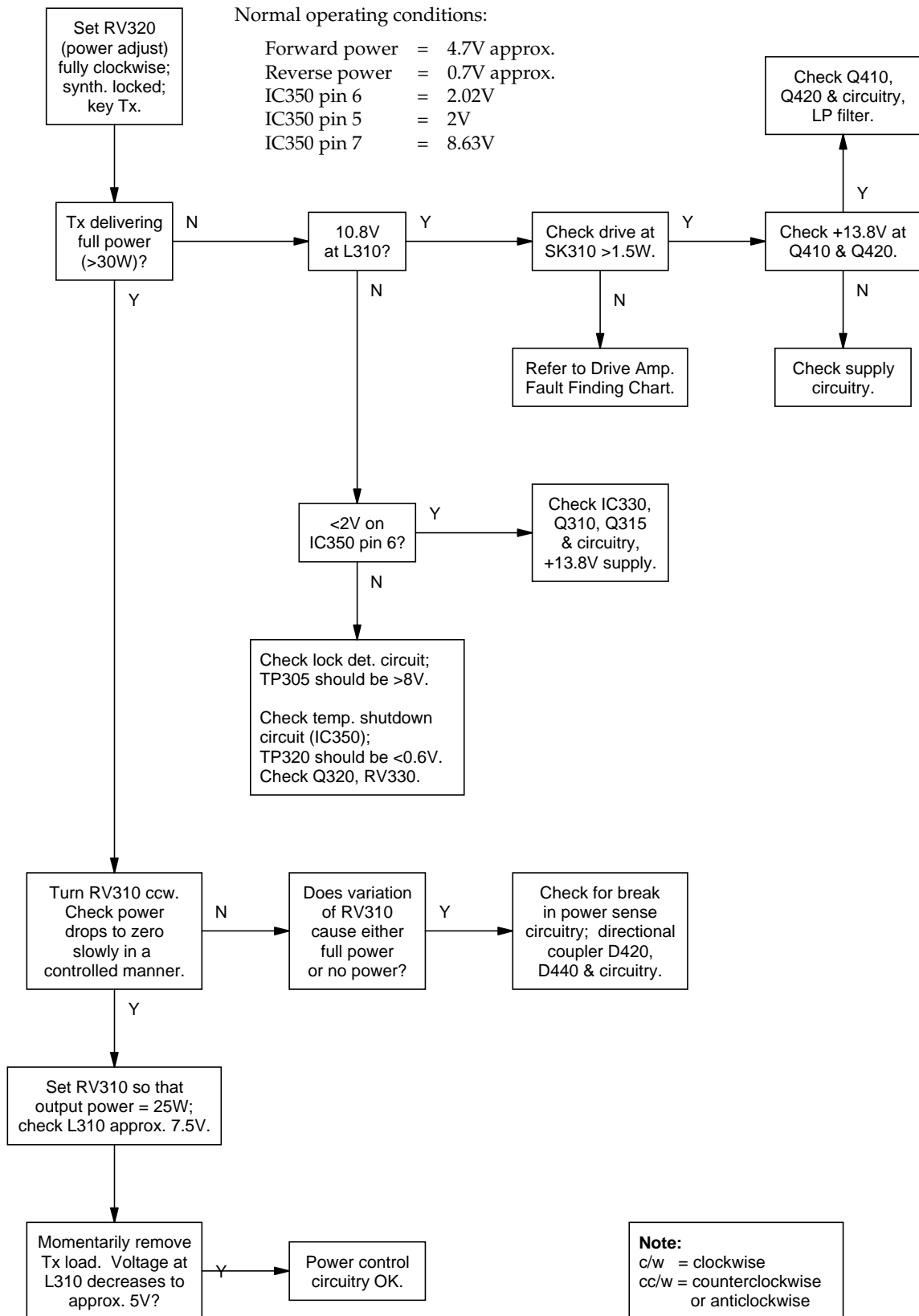

## 5.7.6 T857 Exciter Drive Amplifier

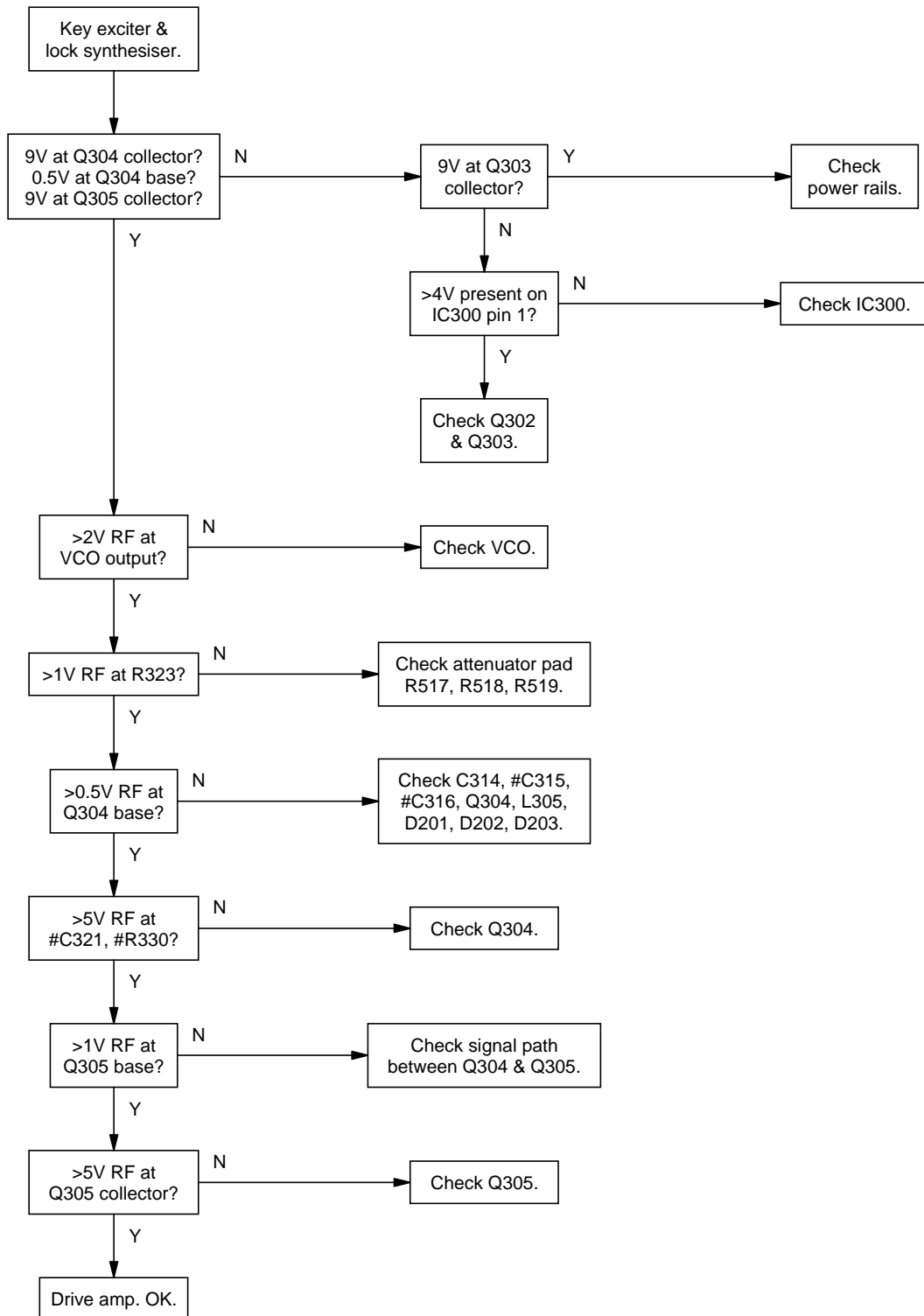

### 5.7.7 Audio Processor

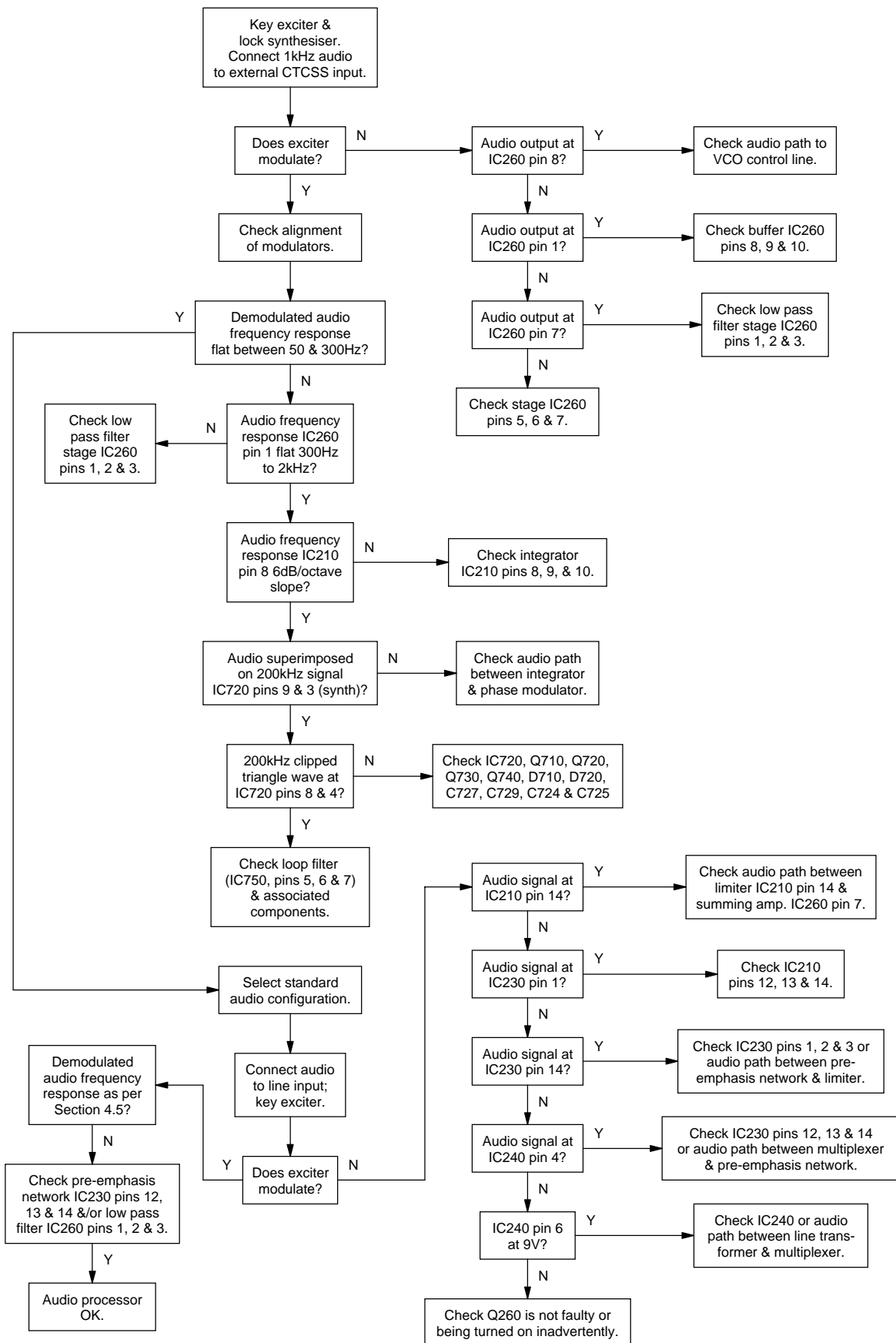

## 5.8 To Replace The T856 PA Transistors (Q410 & Q420)

**Caution:**

Failure to comply with the following procedure can result in failure of the device due to poor heatsinking, or worse, can endanger the health of the assembler if the beryllium oxide die carrier is smashed during assembly.

**Caution:**

As the location of certain components in the PA is critical to performance, it is important that any components removed or disturbed are refitted in *exactly* the same position.

Before attempting to remove a transistor, measure the distance between the capacitors and transistor body to the nearest 0.5mm (measurement "A" in Figure 5.2) so that the capacitors can be replaced in *exactly* the same position. These measurements are shown in Figure 5.2 for the 6LFL package, however the same procedure applies for the SOE (stud) package.

**Caution:**

Do not apply too much heat or pressure to the PCB pads and tracks as you may damage them or lift them from the PCB, causing permanent damage to the transmitter.

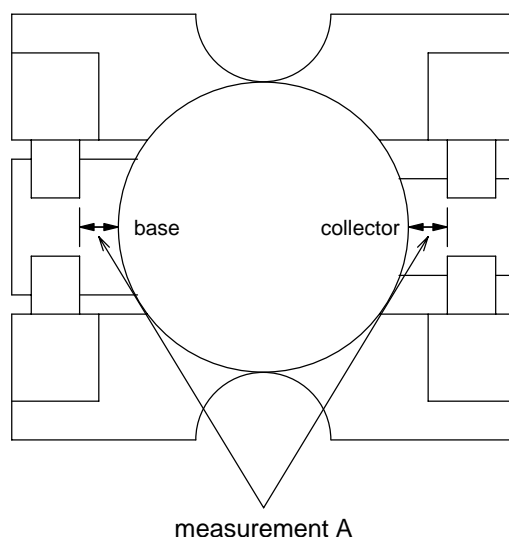

**Figure 5.2 Typical Transistor/Capacitor Spacing (Not To Scale)**

Desolder and remove the components from around the transistor.

**Q420 Only:** Desolder and remove the two solder tags.

Desolder the transistor tabs by heating with a soldering iron and lifting away from the PCB with a screwdriver or thin stainless steel spike, then remove the device.

**Q410 Only:** Unscrew the transistor stud nut and remove the device.

Remove any excess solder from the PCB pads with solder wick.

Trim the tabs of the replacement transistor so that the device sits neatly on the PCB pads provided.

Lightly tin the underside of the transistor tabs.

Apply a small amount of heatsink compound (Dow-Corning 340 or equivalent) to the transistor mounting surface. Sufficient compound should be used to ensure an even film over the entire mounting surface.

Place the transistor on the PCB in the correct orientation and ensure the tabs are flush to the surface.

**Q410 Only:** Lightly solder one tab to the PCB, then torque down the retaining nut to the correct torque (0.7Nm/6in.lbf.).



**Caution:** Do not solder all the tabs before torquing down otherwise the device may be broken.

**Q420 Only:** Refit the solder tags.

Solder all transistor tabs to the PCB.

Replace each component in exactly the same position as noted previously.



## T857 Parts List (IPN 220-01398-04)

### How To Use This Parts List

The components listed in this parts list are divided into two main types: those with a circuit reference (e.g. C2, D1, R121, etc.) and those without (miscellaneous and mechanical).

Those with a circuit reference are grouped in alphabetical order and then in numerical order within each group. Each component entry comprises three or four columns: the circuit reference, variant (if applicable), IPN and description. A number in the variant column indicates that this is a variant component which is fitted only to the product type listed. Static sensitive devices are indicated by an (S) at the start of the description column.

The miscellaneous and mechanical section lists the variant and common parts in IPN order. Where possible, a number in the legend column indicates their position in the mechanical assembly drawing.

The Parts List Amendments box below lists component changes that took place after the parts list and diagrams in this section were compiled. These changes (e.g. value changes, added/deleted components, etc.) are listed by circuit reference in alphanumeric order and supersede the information given in the parts list or diagrams. Components without circuit references are listed in IPN order.

### Parts List Amendments

&C289	T857-16-0500: T857-26-0500: T857-36-0500:	} changed from 68nF (IPN 015-25680-08) to 100nF (IPN 015-26100-08) to meet FCC Type Approval specification (710994).
C600	Deleted	
C601	Changed from 1nF (IPN 015-24100-08) to 22pF (IPN 015-22220-01)	
C757	Changed from 22nF (IPN 015-25220-08) to 47nF (IPN 015-25470-08)	} to improve cyclic keying (710980).
&R264	T857-16-0500: T857-26-0500: T857-36-0500:	

Ref	Var	IPN	Description
-----	-----	-----	-------------

Ref	Var	IPN	Description
-----	-----	-----	-------------

**Note:** %D205 and %D210 are optional level limiting diodes for special applications.

=R705 (47 ohm) and =SK710 are fitted in place of =IC700 when an external frequency reference is used. These two components are supplied with the auxiliary D-range kits (T800-06-0000 & T800-06-0001).

C201		016-07470-06	CAP SMD ELECT BI-P 4U7 50V 20%
C202		016-07470-06	CAP SMD ELECT BI-P 4U7 50V 20%
C204		016-07470-06	CAP SMD ELECT BI-P 4U7 50V 20%
C205		016-07470-06	CAP SMD ELECT BI-P 4U7 50V 20%
C207		014-07470-00	CAP TANT CHIP 4U7 3.5 X 2.8MM
C209		015-25470-08	CAP CER 0805 47N 10% X7R 50V
C210		015-06100-08	CAP CER 1206 100N 10% X7R 50V
C211		015-06100-08	CAP CER 1206 100N 10% X7R 50V
C213		014-08100-00	CAP TANT CHIP 10M 16VW +-20%
C215		014-08220-01	(L)CAP TANT 22UF10V276MSER
C217		015-24220-08	CAP CER 0805 2N2 10% X7R 50V
C219		015-24100-08	CAP CER 0805 1N 10% X7R 50V
C221		014-08220-01	(L)CAP TANT 22UF10V276MSER
C223		015-06100-08	CAP CER 1206 100N 10% X7R 50V
C225		015-06100-08	CAP CER 1206 100N 10% X7R 50V
C227		015-06100-08	CAP CER 1206 100N 10% X7R 50V
C229		015-23150-01	CAP CER 0805 150P 5% NPO 50V
C230		015-06100-08	CAP CER 1206 100N 10% X7R 50V
C232		015-23150-01	CAP CER 0805 150P 5% NPO 50V
C233		016-08470-03	CAP SMD ELEC 47mF 20% 25v 8.3mm
C235		015-24100-08	CAP CER 0805 1N 10% X7R 50V
C237		014-07100-02	CAP TANT CHIP 1U0 3.2 X 1.6MM
C239		016-07470-06	CAP SMD ELECT BI-P 4U7 50V 20%
C241		015-06100-08	CAP CER 1206 100N 10% X7R 50V
C242		014-08100-00	CAP TANT CHIP 10M 16VW +-20%
C243		015-24100-08	CAP CER 0805 1N 10% X7R 50V
C245		015-23150-01	CAP CER 0805 150P 5% NPO 50V
C247		015-23150-01	CAP CER 0805 150P 5% NPO 50V
C249		015-24100-08	CAP CER 0805 1N 10% X7R 50V
C251		015-24100-08	CAP CER 0805 1N 10% X7R 50V
C253		015-24100-08	CAP CER 0805 1N 10% X7R 50V
C255		015-24100-08	CAP CER 0805 1N 10% X7R 50V
C257		015-22470-01	CAP CER 0805 47P 5% NPO 50V
C259		015-25470-08	CAP CER 0805 47N 10% X7R 50V
C260		015-06100-08	CAP CER 1206 100N 10% X7R 50V
C261		014-07470-00	CAP TANT CHIP 4U7 3.5 X 2.8MM
C263		016-09100-05	CAP SMD ELECT 100U 25V 20%
C265		016-07470-06	CAP SMD ELECT BI-P 4U7 50V 20%
C267		015-24470-08	CAP CER 0805 4N7 10% X7R 50V
&C269 10		015-21150-01	CAP CER 0805 1P5+-1/4P NPO 50V
&C269 13		015-21150-01	CAP CER 0805 1P5+-1/4P NPO 50V
&C269 15		015-21470-01	CAP CER 0805 4P7+-1/4P NPO 50V
&C269 16		015-21470-01	CAP CER 0805 4P7+-1/4P NPO 50V
&C269 20		015-21150-01	CAP CER 0805 1P5+-1/4P NPO 50V
&C269 23		015-21150-01	CAP CER 0805 1P5+-1/4P NPO 50V
&C269 25		015-21470-01	CAP CER 0805 4P7+-1/4P NPO 50V
&C269 26		015-21470-01	CAP CER 0805 4P7+-1/4P NPO 50V
&C269 30		015-21150-01	CAP CER 0805 1P5+-1/4P NPO 50V
&C269 35		015-21470-01	CAP CER 0805 4P7+-1/4P NPO 50V
&C269 36		015-21470-01	CAP CER 0805 4P7+-1/4P NPO 50V
&C271 10		015-22470-01	CAP CER 0805 47P 5% NPO 50V
&C271 13		015-22470-01	CAP CER 0805 47P 5% NPO 50V
&C271 15		015-22470-01	CAP CER 0805 47P 5% NPO 50V
&C271 16		015-22560-01	CAP CER 0805 56P 5% NPO 50V
&C271 20		015-22470-01	CAP CER 0805 47P 5% NPO 50V
&C271 23		015-22470-01	CAP CER 0805 47P 5% NPO 50V
&C271 25		015-22470-01	CAP CER 0805 47P 5% NPO 50V
&C271 26		015-22560-01	CAP CER 0805 56P 5% NPO 50V
&C271 30		015-22470-01	CAP CER 0805 47P 5% NPO 50V
&C271 35		015-22470-01	CAP CER 0805 47P 5% NPO 50V
&C271 36		015-22560-01	CAP CER 0805 56P 5% NPO 50V
C273		015-25470-08	CAP CER 0805 47N 10% X7R 50V
C275		015-23120-01	CAP CER 0805 120P 5% NPO 50V
C277		015-25100-08	CAP CER 0805 10N 10% X7R 50V
C279		015-24100-08	CAP CER 0805 1N 10% X7R 50V
C281		015-25220-08	CAP CER 0805 22N 10% X7R 50V
C283		015-21470-01	CAP CER 0805 4P7+-1/4P NPO 50V
C285		015-21470-01	CAP CER 0805 4P7+-1/4P NPO 50V
C287		016-09100-05	CAP SMD ELECT 100U 25V 20%
&C289 10		015-25470-08	CAP CER 0805 47N 10% X7R 50V
&C289 13		015-25470-08	CAP CER 0805 47N 10% X7R 50V
&C289 15		015-25470-08	CAP CER 0805 47N 10% X7R 50V
&C289 16		015-25680-08	CAP CER 0805 68N 10% X7R 50V
&C289 20		015-25470-08	CAP CER 0805 47N 10% X7R 50V
&C289 23		015-25470-08	CAP CER 0805 47N 10% X7R 50V
&C289 25		015-25470-08	CAP CER 0805 47N 10% X7R 50V
&C289 26		015-22560-01	CAP CER 0805 56P 5% NPO 50V
&C289 30		015-25470-08	CAP CER 0805 47N 10% X7R 50V
&C289 35		015-25470-08	CAP CER 0805 47N 10% X7R 50V
&C289 36		015-25680-08	CAP CER 0805 68N 10% X7R 50V
C291		014-08220-01	(L)CAP TANT 22UF10V276MSER
C293		015-27100-10	CAP CER 0805 1M+80-20% Y5V 16V
%C294		015-22470-01	CAP CER 0805 47P 5% NPO 50V
%C295		013-06470-00	CAP SMD POLYESTER 470N 63V 10%
C300A		016-08100-01	CAP EL 6X4 10M 20% 16V

C300B		015-25100-08	CAP CER 0805 10N 10% X7R 50V
C301		015-23150-01	CAP CER 0805 150P 5% NPO 50V
C302		015-24470-08	CAP CER 0805 4N7 10% X7R 50V
C303		015-25100-08	CAP CER 0805 10N 10% X7R 50V
C304		015-24100-08	CAP CER 0805 1N 10% X7R 50V
C305		015-23100-01	CAP CER 0805 100P 5% NPO 50V
C306		015-23100-01	CAP CER 0805 100P 5% NPO 50V
C307		015-23150-01	CAP CER 0805 150P 5% NPO 50V
C308		015-23150-01	CAP CER 0805 150P 5% NPO 50V
C309		015-23150-01	CAP CER 0805 150P 5% NPO 50V
C310		015-23150-01	CAP CER 0805 150P 5% NPO 50V
C311		015-23150-01	CAP CER 0805 150P 5% NPO 50V
C312		015-23150-01	CAP CER 0805 150P 5% NPO 50V
C313		015-22220-01	CAP CER 0805 22P 5% NPO 50V
C314		015-23150-01	CAP CER 0805 150P 5% NPO 50V
#C315 10		015-22120-01	CAP CER 0805 12P 5% NPO 50V
#C315 13		015-22120-01	CAP CER 0805 12P 5% NPO 50V
#C315 15		015-22120-01	CAP CER 0805 12P 5% NPO 50V
#C315 16		015-22120-01	CAP CER 0805 12P 5% NPO 50V
#C315 20		015-21820-01	CAP CER 0805 8P2+-1/4P NPO 50V
#C315 23		015-21820-01	CAP CER 0805 8P2+-1/4P NPO 50V
#C315 25		015-21820-01	CAP CER 0805 8P2+-1/4P NPO 50V
#C315 26		015-21820-01	CAP CER 0805 8P2+-1/4P NPO 50V
#C315 30		015-21560-01	CAP CER 0805 5P6+-1/4P NPO 50V
#C315 35		015-21560-01	CAP CER 0805 5P6+-1/4P NPO 50V
#C315 36		015-21560-01	CAP CER 0805 5P6+-1/4P NPO 50V
#C316 10		015-22330-01	CAP CER 0805 33P 5% NPO 50V
#C316 13		015-22330-01	CAP CER 0805 33P 5% NPO 50V
#C316 15		015-22330-01	CAP CER 0805 33P 5% NPO 50V
#C316 16		015-22330-01	CAP CER 0805 33P 5% NPO 50V
#C316 20		015-22270-01	CAP CER 0805 27P 5% NPO 50V
#C316 23		015-22270-01	CAP CER 0805 27P 5% NPO 50V
#C316 25		015-22270-01	CAP CER 0805 27P 5% NPO 50V
#C316 26		015-22270-01	CAP CER 0805 27P 5% NPO 50V
#C316 30		015-22220-01	CAP CER 0805 22P 5% NPO 50V
#C316 35		015-22220-01	CAP CER 0805 22P 5% NPO 50V
#C316 36		015-22220-01	CAP CER 0805 22P 5% NPO 50V
C317		020-07470-04	CAP ELE RA 4M7 25V 20%8X13 SOL
C318		015-24100-08	CAP CER 0805 1N 10% X7R 50V
C319		015-24100-08	CAP CER 0805 1N 10% X7R 50V
C320		015-24100-08	CAP CER 0805 1N 10% X7R 50V
#C321 10		015-22220-01	CAP CER 0805 22P 5% NPO 50V
#C321 13		015-22220-01	CAP CER 0805 22P 5% NPO 50V
#C321 15		015-22220-01	CAP CER 0805 22P 5% NPO 50V
#C321 16		015-22220-01	CAP CER 0805 22P 5% NPO 50V
#C321 20		015-22220-01	CAP CER 0805 22P 5% NPO 50V
#C321 23		015-22220-01	CAP CER 0805 22P 5% NPO 50V
#C321 25		015-22220-01	CAP CER 0805 22P 5% NPO 50V
#C321 26		015-22220-01	CAP CER 0805 22P 5% NPO 50V
#C321 30		015-22100-01	CAP CER 0805 10P+-1/2P NPO 50V
#C321 35		015-22100-01	CAP CER 0805 10P+-1/2P NPO 50V
#C321 36		015-22100-01	CAP CER 0805 10P+-1/2P NPO 50V
#C322 10		015-21680-01	CAP CER 0805 6P8+-1/4P NPO 50V
#C322 13		015-21680-01	CAP CER 0805 6P8+-1/4P NPO 50V
#C322 15		015-21680-01	CAP CER 0805 6P8+-1/4P NPO 50V
#C322 16		015-21680-01	CAP CER 0805 6P8+-1/4P NPO 50V
#C322 20		015-22100-01	CAP CER 0805 10P+-1/2P NPO 50V
#C322 23		015-22100-01	CAP CER 0805 10P+-1/2P NPO 50V
#C322 25		015-22100-01	CAP CER 0805 10P+-1/2P NPO 50V
#C322 26		015-22100-01	CAP CER 0805 10P+-1/2P NPO 50V
#C322 30		015-21820-01	CAP CER 0805 8P2+-1/4P NPO 50V
#C322 35		015-21820-01	CAP CER 0805 8P2+-1/4P NPO 50V
#C322 36		015-21820-01	CAP CER 0805 8P2+-1/4P NPO 50V
#C323 10		015-22330-01	CAP CER 0805 33P 5% NPO 50V
#C323 13		015-22330-01	CAP CER 0805 33P 5% NPO 50V
#C323 15		015-22330-01	CAP CER 0805 33P 5% NPO 50V
#C323 16		015-22330-01	CAP CER 0805 33P 5% NPO 50V
#C323 20		015-22330-01	CAP CER 0805 33P 5% NPO 50V
#C323 23		015-22330-01	CAP CER 0805 33P 5% NPO 50V
#C323 25		015-22330-01	CAP CER 0805 33P 5% NPO 50V
#C323 26		015-22330-01	CAP CER 0805 33P 5% NPO 50V
#C323 30		015-22270-01	CAP CER 0805 27P 5% NPO 50V
#C323 35		015-22270-01	CAP CER 0805 27P 5% NPO 50V
#C323 36		015-22270-01	CAP CER 0805 27P 5% NPO 50V
C324		015-24100-08	CAP CER 0805 1N 10% X7R 50V
C325		015-06100-08	CAP CER 1206 100N 10% X7R 50V
#C326 10		015-22220-01	CAP CER 0805 22P 5% NPO 50V
#C326 13		015-22220-01	CAP CER 0805 22P 5% NPO 50V
#C326 15		015-22220-01	CAP CER 0805 22P 5% NPO 50V
#C326 16		015-22220-01	CAP CER 0805 22P 5% NPO 50V
#C326 20		015-21820-01	CAP CER 0805 8P2+-1/4P NPO 50V
#C326 23		015-21820-01	CAP CER 0805 8P2+-1/4P NPO 50V
#C326 25		015-21820-01	CAP CER 0805 8P2+-1/4P NPO 50V
#C326 26		015-21820-01	CAP CER 0805 8P2+-1/4P NPO 50V
#C326 30		015-21820-01	CAP CER 0805 8P2+-1/4P NPO 50V
#C326 35		015-21820-01	CAP CER 0805 8P2+-1/4P NPO 50V
#C326 36		015-21820-01	CAP CER 0805 8P2+-1/4P NPO 50V
#C327 10		015-21220-01	CAP CER 0805 2P2+-1/4P NPO 50V
#C327 13		015-21220-01	CAP CER 0805 2P2+-1/4P NPO 50V
#C327 15		015-21220-01	CAP CER 0805 2P2+-1/4P NPO 50V
#C327 16		015-21220-01	CAP CER 0805 2P2+-1/4P NPO 50V
#C327 20		015-21150-01	CAP CER 0805 1P5+-1/4P NPO 50V
#C327 23		015-21150-01	CAP CER 0805 1P5+-1/4P NPO 50V
#C327 25		015-21150-01	CAP CER 0805 1P5+-1/4P NPO 50V
#C327 26		015-21150-01	CAP CER 0805 1P5+-1/4P NPO 50V
#C327 30		015-21330-01	CAP CER 0805 3P3+-1/4P NPO 50V
#C327 35		015-21330-01	CAP CER 0805 3P3+-1/4P NPO 50V
#C327 36		015-21330-01	CAP CER 0805 3P3+-1/4P NPO 50V

Ref	Var	IPN	Description	Ref	Var	IPN	Description
C328		015-23150-01	CAP CER 0805 150P 5% NPO 50V	C750		014-08100-03	CAP TANT SMD 10U 35V 20%
C329		015-23150-01	CAP CER 0805 150P 5% NPO 50V	C757		015-25220-08	CAP CER 0805 22N 10% X7R 50V
C330		015-23150-01	CAP CER 0805 150P 5% NPO 50V	C759		015-25100-08	CAP CER 0805 10N 10% X7R 50V
C331		015-25150-08	CAP CER 0805 15N 10% X7R 50V	C761		015-25100-08	CAP CER 0805 10N 10% X7R 50V
C332		015-06100-08	CAP CER 1206 100N 10% X7R 50V	C762		014-08220-01	(L)CAP TANT 22UF10V276MSER
C333		015-25100-08	CAP CER 0805 10N 10% X7R 50V	C764		015-25100-08	CAP CER 0805 10N 10% X7R 50V
C334		015-23150-01	CAP CER 0805 150P 5% NPO 50V	C765		014-07470-00	CAP TANT CHIP 4U7 3.5 X 2.8MM
C336		015-24100-08	CAP CER 0805 1N 10% X7R 50V	C767		015-24100-08	CAP CER 0805 1N 10% X7R 50V
C337		015-23150-01	CAP CER 0805 150P 5% NPO 50V	C769		015-24100-08	CAP CER 0805 1N 10% X7R 50V
C340		015-23150-01	CAP CER 0805 150P 5% NPO 50V	C770		014-08220-01	(L)CAP TANT 22UF10V276MSER
C341		015-23150-01	CAP CER 0805 150P 5% NPO 50V	C772		014-08220-01	(L)CAP TANT 22UF10V276MSER
C342		015-23150-01	CAP CER 0805 150P 5% NPO 50V	C774		013-06100-10	CAP SMD PPS 100N 100V 10%
#C345	10	015-23120-01	CAP CER 0805 120P 5% NPO 50V	C776		015-24470-08	CAP CER 0805 4N7 10% X7R 50V
#C345	13	015-23120-01	CAP CER 0805 120P 5% NPO 50V	C782		015-23120-01	CAP CER 0805 120P 5% NPO 50V
#C345	15	015-23120-01	CAP CER 0805 120P 5% NPO 50V	C784		015-23120-01	CAP CER 0805 120P 5% NPO 50V
#C345	16	015-23120-01	CAP CER 0805 120P 5% NPO 50V	C786		015-06100-08	CAP CER 1206 100N 10% X7R 50V
#C345	20	015-23120-01	CAP CER 0805 120P 5% NPO 50V	C788		015-23120-01	CAP CER 0805 120P 5% NPO 50V
#C345	23	015-23120-01	CAP CER 0805 120P 5% NPO 50V	C790		015-21820-01	CAP CER 0805 8P2+1/4P NPO 50V
#C345	25	015-23120-01	CAP CER 0805 120P 5% NPO 50V	C792		015-23120-01	CAP CER 0805 120P 5% NPO 50V
#C345	26	015-23120-01	CAP CER 0805 120P 5% NPO 50V	C810		015-25470-08	CAP CER 0805 47N 10% X7R 50V
#C345	30	015-23120-01	CAP CER 0805 120P 5% NPO 50V	C812		015-23100-01	CAP CER 0805 100P 5% NPO 50V
#C345	35	015-23120-01	CAP CER 0805 120P 5% NPO 50V	C813		015-24100-08	CAP CER 0805 1N 10% X7R 50V
#C345	36	015-23120-01	CAP CER 0805 120P 5% NPO 50V	C822		014-07470-00	CAP TANT CHIP 4U7 3.5 X 2.8MM
C350		015-24100-08	CAP CER 0805 1N 10% X7R 50V	C823		015-25220-08	CAP CER 0805 22N 10% X7R 50V
C351		015-24100-08	CAP CER 0805 1N 10% X7R 50V	C824		015-25470-08	CAP CER 0805 47N 10% X7R 50V
C354		015-23150-01	CAP CER 0805 150P 5% NPO 50V	C826		015-23220-01	CAP CER 0805 220P 5% NPO 50V
C360		015-23120-01	CAP CER 0805 120P 5% NPO 50V	C827		015-22330-01	CAP CER 0805 33P 5% NPO 50V
C503		015-24470-08	CAP CER 0805 4N7 10% X7R 50V	C828		015-25100-08	CAP CER 0805 10N 10% X7R 50V
C505		015-25470-08	CAP CER 0805 47N 10% X7R 50V	C830		015-25470-08	CAP CER 0805 47N 10% X7R 50V
C510		015-25150-08	CAP CER 0805 15N 10% X7R 50V	C838		014-09100-00	CAP TANT SMD 100U 16V 20%
C513		015-25100-08	CAP CER 0805 10N 10% X7R 50V	C841		014-09100-00	CAP TANT SMD 100U 16V 20%
C514		015-23150-01	CAP CER 0805 150P 5% NPO 50V	C844		015-25100-08	CAP CER 0805 10N 10% X7R 50V
C515		015-23150-01	CAP CER 0805 150P 5% NPO 50V	C910		015-01680-06	CAP CER 1210 6P8 NPO500VGRM42
C516		015-23150-01	CAP CER 0805 150P 5% NPO 50V	C920		015-02120-06	CAP CER 1210 12P NPO500VGRM42
C535		015-06100-08	CAP CER 1206 100N 10% X7R 50V	C930		015-01680-06	CAP CER 1210 6P8 NPO500VGRM42
C536		015-23100-01	CAP CER 0805 100P 5% NPO 50V	D111		001-00012-90	S) DIODE MR2520L O-VOLT SUPP
C537		015-23100-01	CAP CER 0805 100P 5% NPO 50V	D111A		001-10024-00	DIODE LDP24M 24V SUR-PROT SMD
C545		015-23150-01	CAP CER 0805 150P 5% NPO 50V	D220		001-10000-99	S) DIODE SMD BAV99 D-SW SOT23
C546		015-23150-01	CAP CER 0805 150P 5% NPO 50V	D230		001-10010-40	DIODE SMD ZENER 33V BZG03-C33
C550		014-08220-01	(L)CAP TANT 22UF10V276MSER	D240		001-10000-56	S) DIODE SMD BAW56 D-SW SOT23
C600		015-24100-08	CAP CER 0805 1N 10% X7R 50V	D250		001-10000-56	S) DIODE SMD BAW56 D-SW SOT23
C601		015-24100-08	CAP CER 0805 1N 10% X7R 50V	D260		001-10000-56	S) DIODE SMD BAW56 D-SW SOT23
C605		015-23120-01	CAP CER 0805 120P 5% NPO 50V	D270		001-10000-99	S) DIODE SMD BAV99 D-SW SOT23
C610A		015-25100-08	CAP CER 0805 10N 10% X7R 50V	D301		001-10000-18	S) DIODE SMD BAT18 S-SW SOT23
C610B		014-09100-00	CAP TANT SMD 100U 16V 20%	D302		001-10000-18	S) DIODE SMD BAT18 S-SW SOT23
C611A		014-09100-00	CAP TANT SMD 100U 16V 20%	D303		001-10000-18	S) DIODE SMD BAT18 S-SW SOT23
C611B		015-25100-08	CAP CER 0805 10N 10% X7R 50V	D510		001-10000-70	S) DIODE SMD BAV70 D-SW SOT23
C615		015-24100-08	CAP CER 0805 1N 10% X7R 50V	D610		001-10000-99	S) DIODE SMD BAV99 D-SW SOT23
C616		015-24100-08	CAP CER 0805 1N 10% X7R 50V	D620		001-10000-70	S) DIODE SMD BAV70 D-SW SOT23
C623		015-23120-01	CAP CER 0805 120P 5% NPO 50V	D630		001-10000-70	S) DIODE SMD BAV70 D-SW SOT23
C625		020-09470-07	CAPEL470M16V20%V 8*20 3.5L.ESR	D635		001-10065-00	DIODE SHTKY SOD123 BAT65 BAT54
C626		015-24470-08	CAP CER 0805 4N7 10% X7R 50V	D640		001-10000-70	S) DIODE SMD BAV70 D-SW SOT23
C628		015-24100-08	CAP CER 0805 1N 10% X7R 50V	D645		001-10010-40	DIODE SMD ZENER 33V BZG03-C33
C630		015-06100-08	CAP CER 1206 100N 10% X7R 50V	D710		001-10000-99	S) DIODE SMD BAV99 D-SW SOT23
C631A		015-06100-08	CAP CER 1206 100N 10% X7R 50V	D720		001-10000-99	S) DIODE SMD BAV99 D-SW SOT23
C634		014-08100-00	CAP TANT CHIP 10M 16VW +20%	D730		001-10065-00	DIODE SHTKY SOD123 BAT65 BAT54
C636		015-06100-08	CAP CER 1206 100N 10% X7R 50V	D740		001-10065-00	DIODE SHTKY SOD123 BAT65 BAT54
C638		015-23120-01	CAP CER 0805 120P 5% NPO 50V	D810		001-10065-00	DIODE SHTKY SOD123 BAT65 BAT54
C640		015-24100-08	CAP CER 0805 1N 10% X7R 50V	IC210		002-10003-24	S) IC SMD 324 4X O-AMP SO14
C655		015-24100-08	CAP CER 0805 1N 10% X7R 50V	IC220		002-10126-70	S) IC SMD DS1267S10K 2XDIG POT
C660		015-06100-08	CAP CER 1206 100N 10% X7R 50V	IC230		002-10003-24	S) IC SMD 324 4X O-AMP SO14
C665		014-08100-03	CAP TANT SMD 10U 35V 20%	IC240		002-10040-53	S)MCM14053B SMD BREAK B4 MAKE
C670		014-07330-10	CAP TANT SMD 3U3 35V 10%	IC250		002-10020-50	IC SMD 4N25A OPTOCOUPLER
C673		015-24470-08	CAP CER 0805 4N7 10% X7R 50V	IC260		002-10003-24	S) IC SMD 324 4X O-AMP SO14
C677		014-07100-02	CAP TANT CHIP 1U0 3.2 X 1.6MM	IC300		002-10003-58	S) IC SMD LM358 DUAL O-AMP
C681		015-06100-08	CAP CER 1206 100N 10% X7R 50V	IC610		002-10078-05	S) IC SMD 78L05 5V REG
C684		014-08100-00	CAP TANT CHIP 10M 16VW +20%	IC630		002-10003-17	(S) IC LM317L REG SO-8 100MA
C687		015-23120-01	CAP CER 0805 120P 5% NPO 50V	IC640		002-10003-58	S) IC SMD LM358 DUAL O-AMP
C690		015-06100-08	CAP CER 1206 100N 10% X7R 50V	IC650		002-10012-32	SMD DS1232LPS-2 LP RESET&W-DOG
C693		014-08100-00	CAP TANT CHIP 10M 16VW +20%	-IC700		539-00010-50	TCXO 12.8MHZ +-1PPM -20 +70C
C700		015-06100-08	CAP CER 1206 100N 10% X7R 50V	IC710		002-74900-04	S) IC SMD 74HC04D 6X INV BUFFD
C703		015-24100-08	CAP CER 0805 1N 10% X7R 50V	IC720		002-74910-04	S) IC SMD 74HCU04 6X INV
C706		015-22470-01	CAP CER 0805 47P 5% NPO 50V	IC730		002-10045-20	S) IC SMD 74HC4520T 2XCTR 4BIT
C708		014-07470-00	CAP TANT CHIP 4U7 3.5 X 2.8MM	IC740		002-14519-10	S) IC MC145191F SMD SYNTH
C709		015-06100-08	CAP CER 1206 100N 10% X7R 50V	IC750		002-10330-78	S) IC MC33078D 2X AMP LO NOISE
C710		015-25100-08	CAP CER 0805 10N 10% X7R 50V	IC810		002-08951-20	S) IC AT89C51 PLCC44 MIC 12MHZ
C711		015-06100-08	CAP CER 1206 100N 10% X7R 50V	IC820		002-12416-00	S)IC SMD AT24C16N-10SC EEPROM
C712		015-22470-01	CAP CER 0805 47P 5% NPO 50V	IC830		002-10003-24	S) IC SMD 324 4X O-AMP SO14
C714		014-07470-00	CAP TANT CHIP 4U7 3.5 X 2.8MM	L300		065-10004-20	BEAD FE SMD CBDN 4.6/3/3-4S2
C719		014-07470-00	CAP TANT CHIP 4U7 3.5 X 2.8MM	L302		056-10330-02	(L) IND SMD 330NH
C720		015-06100-08	CAP CER 1206 100N 10% X7R 50V	L303		065-10004-20	BEAD FE SMD CBDN 4.6/3/3-4S2
C722		015-06100-08	CAP CER 1206 100N 10% X7R 50V	L305		056-10330-02	(L) IND SMD 330NH
C724		014-08220-01	(L)CAP TANT 22UF10V276MSER	#L307	10	052-08130-15	COIL A/W 1.5T/3.0MM HOR 0.8MM
C725		014-08220-01	(L)CAP TANT 22UF10V276MSER	#L307	13	052-08130-15	COIL A/W 1.5T/3.0MM HOR 0.8MM
C726		015-25100-08	CAP CER 0805 10N 10% X7R 50V	#L307	15	052-08130-15	COIL A/W 1.5T/3.0MM HOR 0.8MM
C727		015-23220-01	CAP CER 0805 220P 5% NPO 50V	#L307	16	052-08130-15	COIL A/W 1.5T/3.0MM HOR 0.8MM
C729		015-23220-01	CAP CER 0805 220P 5% NPO 50V	#L307	20	052-08130-15	COIL A/W 1.5T/3.0MM HOR 0.8MM
%C733		015-23470-08	CAP CER 0805 470P 10% X7R 50V	#L307	23	052-08130-15	COIL A/W 1.5T/3.0MM HOR 0.8MM
C735		015-22470-01	CAP CER 0805 47P 5% NPO 50V	#L307	25	052-08130-15	COIL A/W 1.5T/3.0MM HOR 0.8MM
C736		015-22470-01	CAP CER 0805 47P 5% NPO 50V	#L307	26	052-08130-15	COIL A/W 1.5T/3.0MM HOR 0.8MM
C740A		015-24100-08	CAP CER 0805 1N 10% X7R 50V	#L307	30	052-08120-15	COIL A/W 1.5T/2MM HOR 0.8MM
C740B		015-25100-08	CAP CER 0805 10N 10% X7R 50V	#L307	35	052-08120-15	COIL A/W 1.5T/2MM HOR 0.8MM
C741A		014-07470-00	CAP TANT CHIP 4U7 3.5 X 2.8MM	#L307	36	052-08120-15	COIL A/W 1.5T/2MM HOR 0.8MM
C741B		015-25100-08	CAP CER 0805 10N 10% X7R 50V	L309		065-00010-01	BEAD FERR 3B 6 HOLE
C742A		015-06100-08	CAP CER 1206 100N 10% X7R 50V	L312		052-08130-65	COIL A/W 6.5T/3.0MM HOR 0.8MM
C742B		015-25100-08	CAP CER 0805 10N 10% X7R 50V				
C743		015-22470-01	CAP CER 0805 47P 5% NPO 50V				
C745		015-23120-01	CAP CER 0805 120P 5% NPO 50V				

Ref	Var	IPN	Description	Ref	Var	IPN	Description
#L313	10	052-08130-15	COIL A/W 1.5T/3.0MM HOR 0.8MM	R226		036-15100-00	RES M/F 0805 10K 5%
#L313	13	052-08130-15	COIL A/W 1.5T/3.0MM HOR 0.8MM	R227		036-14220-00	RES M/F 0805 2K2 5%
#L313	15	052-08130-15	COIL A/W 1.5T/3.0MM HOR 0.8MM	R228		036-13120-00	RES M/F 0805 120E 5%
#L313	16	052-08130-15	COIL A/W 1.5T/3.0MM HOR 0.8MM	R229		036-16470-00	RES M/F 0805 470K 5%
#L313	20	052-08120-15	COIL A/W 1.5T/2MM HOR 0.8MM	R230		036-16100-00	RES M/F 0805 100K 5%
#L313	23	052-08120-15	COIL A/W 1.5T/2MM HOR 0.8MM	R231		036-15100-00	RES M/F 0805 10K 5%
#L313	25	052-08120-15	COIL A/W 1.5T/2MM HOR 0.8MM	R232		036-16330-00	RES M/F 0805 330K 5%
#L313	26	052-08120-15	COIL A/W 1.5T/2MM HOR 0.8MM	R233		036-16100-00	RES M/F 0805 100K 5%
#L313	30	052-08120-15	COIL A/W 1.5T/2MM HOR 0.8MM	R235		036-14470-00	RES M/F 0805 4K7 5%
#L313	35	052-08120-15	COIL A/W 1.5T/2MM HOR 0.8MM	R237		036-15470-00	RES M/F 0805 47K 5%
#L313	36	052-08120-15	COIL A/W 1.5T/2MM HOR 0.8MM	R238		036-15470-00	RES M/F 0805 47K 5%
L314		056-10330-02	(L) IND SMD 330NH	R239		036-14150-00	RES M/F 0805 1K5 5%
L350		057-10120-03	IND 805 EMI SUP 120E@100M 0.2A	R241		036-14470-00	RES M/F 0805 4K7 5%
L535		057-10120-03	IND 805 EMI SUP 120E@100M 0.2A	R242		036-14220-00	RES M/F 0805 2K2 5%
L600		057-10120-03	IND 805 EMI SUP 120E@100M 0.2A	R244		036-15100-00	RES M/F 0805 10K 5%
L615		057-10120-03	IND 805 EMI SUP 120E@100M 0.2A	R245		036-16100-00	RES M/F 0805 100K 5%
L750		052-08125-15	COIL A/W 1.5T/2.5MM HOR 0.8MM	R247		036-15100-00	RES M/F 0805 10K 5%
L910		052-08130-15	COIL A/W 1.5T/3.0MM HOR 0.8MM	R248		036-16100-00	RES M/F 0805 100K 5%
L920		052-08130-15	COIL A/W 1.5T/3.0MM HOR 0.8MM	R249		036-16100-00	RES M/F 0805 100K 5%
PL100		070-01001-00	D-RANGE 15 WAY COMPL T800	R251		036-16100-00	RES M/F 0805 100K 5%
PL205		240-00020-67	HEADER 6W 2X3 PCB MTG STD	R253		036-16100-00	RES M/F 0805 100K 5%
PL210		240-00020-67	HEADER 6W 2X3 PCB MTG STD	R254		036-16100-00	RES M/F 0805 100K 5%
PL215		240-00020-44	HEADER 10W X2R PCB MTG 5*2	R255		036-15100-00	RES M/F 0805 10K 5%
PL220		240-00020-67	HEADER 6W 2X3 PCB MTG STD	R256		036-15470-00	RES M/F 0805 47K 5%
Q210		000-10008-48	S) XSTR SMD BCW60 NPN SOT23 SS	R257		036-16330-00	RES M/F 0805 330K 5%
Q220		000-10008-17	S) XSTR SMD BC817-25 NPN SOT23	R258		036-16150-00	RES M/F 0805 150K 5%
Q230		000-10008-48	S) XSTR SMD BCW60 NPN SOT23 SS	R259		036-15220-00	RES M/F 0805 22K 5%
Q240		000-10008-48	S) XSTR SMD BCW60 NPN SOT23 SS	R260		036-15470-00	RES M/F 0805 47K 5%
Q250		000-10008-17	S) XSTR SMD BC817-25 NPN SOT23	R262		036-15470-00	RES M/F 0805 47K 5%
Q260		000-10008-57	S) XSTR SMD BCW70 PNP SOT23 SS	R263		036-14470-00	RES M/F 0805 4K7 5%
Q270		000-10004-10	S) XSTR SMD MJD41C NPN SW DPAK	&R264	10	036-15220-00	RES M/F 0805 22K 5%
Q301		000-10008-48	S) XSTR SMD BCW60 NPN SOT23 SS	&R264	13	036-15220-00	RES M/F 0805 22K 5%
Q302		000-10008-48	S) XSTR SMD BCW60 NPN SOT23 SS	&R264	15	036-15270-10	RES M/F 0805 27K 1%
Q304		000-00005-55	S) XSTR MRF555 NPN RF LPWR	&R264	16	036-15220-00	RES M/F 0805 22K 5%
Q305		000-00032-56	S) XSTR MRF630 NPN T039 UHF 3W	&R264	20	036-15220-00	RES M/F 0805 22K 5%
Q306		000-10008-07	S) XSTR SMD BC807 PNP SOT23 AF	&R264	23	036-15220-00	RES M/F 0805 22K 5%
Q307		000-10008-07	S) XSTR SMD BC807 PNP SOT23 AF	&R264	25	036-15270-10	RES M/F 0805 27K 1%
Q308		000-10008-07	S) XSTR SMD BC807 PNP SOT23 AF	&R264	26	036-15220-00	RES M/F 0805 22K 5%
Q309		000-10008-57	S) XSTR SMD BCW70 PNP SOT23 SS	&R264	30	036-15220-00	RES M/F 0805 22K 5%
Q310		000-10008-48	S) XSTR SMD BCW60 NPN SOT23 SS	&R264	35	036-15270-10	RES M/F 0805 27K 1%
Q311		000-10008-48	S) XSTR SMD BCW60 NPN SOT23 SS	&R264	36	036-15220-00	RES M/F 0805 22K 5%
Q315		000-00012-15	S) XSTR BD234 PNP AF PWR TO126	&R265	10	036-15150-00	RES M/F 0805 15K 5%
Q505		000-10008-48	S) XSTR SMD BCW60 NPN SOT23 SS	&R265	13	036-15150-00	RES M/F 0805 15K 5%
Q510		000-10008-07	S) XSTR SMD BC807 PNP SOT23 AF	&R265	15	036-15180-10	RES M/F 0805 18K 1%
Q520		000-10008-07	S) XSTR SMD BC807 PNP SOT23 AF	&R265	16	036-15150-00	RES M/F 0805 15K 5%
Q530		000-10008-07	S) XSTR SMD BC807 PNP SOT23 AF	&R265	20	036-15150-00	RES M/F 0805 15K 5%
Q540		000-10008-07	S) XSTR SMD BC807 PNP SOT23 AF	&R265	23	036-15150-00	RES M/F 0805 15K 5%
Q550		000-10008-48	S) XSTR SMD BCW60 NPN SOT23 SS	&R265	25	036-15180-10	RES M/F 0805 18K 1%
Q610		000-10008-07	S) XSTR SMD BC807 PNP SOT23 AF	&R265	26	036-15150-00	RES M/F 0805 15K 5%
Q620		000-00012-15	S) XSTR BD234 PNP AF PWR TO126	&R265	30	036-15150-00	RES M/F 0805 15K 5%
Q630		000-10003-00	S) XSTR BSR30 PNP AF SOT-89	&R265	35	036-15180-10	RES M/F 0805 18K 1%
Q660		000-10008-17	S) XSTR SMD BC817-25 NPN SOT23	&R265	36	036-15150-00	RES M/F 0805 15K 5%
Q670		000-10008-57	S) XSTR SMD BCW70 PNP SOT23 SS	&R266	10	036-15470-10	RES M/F 0805 47K 1%
Q710		000-10008-48	S) XSTR SMD BCW60 NPN SOT23 SS	&R266	13	036-15470-10	RES M/F 0805 47K 1%
Q720		000-10008-57	S) XSTR SMD BCW70 PNP SOT23 SS	&R266	15	036-15560-00	RES M/F 0805 56K 5%
Q730		000-10008-48	S) XSTR SMD BCW60 NPN SOT23 SS	&R266	16	036-15470-10	RES M/F 0805 47K 1%
Q740		000-10008-57	S) XSTR SMD BCW70 PNP SOT23 SS	&R266	20	036-15470-00	RES M/F 0805 47K 5%
Q750		000-10008-07	S) XSTR SMD BC807 PNP SOT23 AF	&R266	23	036-15470-10	RES M/F 0805 47K 1%
Q760		000-10008-48	S) XSTR SMD BCW60 NPN SOT23 SS	&R266	25	036-15560-00	RES M/F 0805 56K 5%
Q770		000-10008-57	S) XSTR SMD BCW70 PNP SOT23 SS	&R266	26	036-15470-10	RES M/F 0805 47K 1%
Q775		000-10008-57	S) XSTR SMD BCW70 PNP SOT23 SS	&R266	30	036-15470-10	RES M/F 0805 47K 1%
Q780		000-10008-48	S) XSTR SMD BCW60 NPN SOT23 SS	R267		036-14220-00	RES M/F 0805 2K2 5%
Q785		000-10008-57	S) XSTR SMD BCW70 PNP SOT23 SS	R268		036-13100-00	RES M/F 0805 100E 5%
Q790		000-10003-12	S) XSTR SMD BFR31 N JFET SOT23	R269		036-15100-00	RES M/F 0805 10K 5%
Q795		000-10057-10	S) XSTR SMD BR571 NPN SOT23	R270		036-14120-00	RES M/F 0805 1K2 5%
Q810		000-10008-48	S) XSTR SMD BCW60 NPN SOT23 SS	R271		036-17100-00	RES M/F 0805 1M 5%
Q820		000-10008-17	S) XSTR SMD BC817-25 NPN SOT23	R272		036-13560-00	RES M/F 0805 560E 5%
Q830		000-10008-57	S) XSTR SMD BCW70 PNP SOT23 SS	R273		036-15120-00	RES M/F 0805 12K 5%
Q840		000-10008-57	S) XSTR SMD BCW70 PNP SOT23 SS	R274		036-15150-00	RES M/F 0805 15K 5%
Q850		000-10008-48	S) XSTR SMD BCW60 NPN SOT23 SS	R275		036-14270-00	RES M/F 0805 2K7 5%
Q860		000-10008-48	S) XSTR SMD BCW60 NPN SOT23 SS	R277		036-16100-00	RES M/F 0805 100K 5%
R160		036-12100-00	RES M/F 0805 10E 5%	R278		036-16120-00	RES M/F 0805 120K 5%
R201		036-13560-00	RES M/F 0805 560E 5%	R279		036-17100-00	RES M/F 0805 1M 5%
R202		036-14100-00	RES M/F 0805 1K 5%	R280		036-15100-00	RES M/F 0805 10K 5%
R204		036-14220-00	RES M/F 0805 2K2 5%	R282		036-15560-00	RES M/F 0805 56K 5%
R205		036-13220-00	RES M/F 0805 220E 5%	R283		036-15560-00	RES M/F 0805 56K 5%
R206		036-14100-00	RES M/F 0805 1K 5%	R284		036-17100-00	RES M/F 0805 1M 5%
R207		036-14390-00	RES M/F 0805 3K9 5%	R285		036-10000-00	RES M/F 0805 ZERO OHM
R208		036-13560-00	RES M/F 0805 560E 5%	R286		036-14220-00	RES M/F 0805 2K2 5%
R209		036-15100-00	RES M/F 0805 10K 5%	R287		036-15100-00	RES M/F 0805 10K 5%
R210		036-14220-00	RES M/F 0805 2K2 5%	R288		036-15120-00	RES M/F 0805 12K 5%
R211		036-13470-00	RES M/F 0805 470E 5%	R289		036-16100-00	RES M/F 0805 100K 5%
R212		036-16100-00	RES M/F 0805 100K 5%	&R290	10	036-13560-00	RES M/F 0805 560E 5%
R213		036-15100-00	RES M/F 0805 10K 5%	&R290	13	036-13560-00	RES M/F 0805 560E 5%
R214		036-14820-00	RES M/F 0805 8K2 5%	&R290	15	036-13560-00	RES M/F 0805 560E 5%
R215		036-16100-00	RES M/F 0805 100K 5%	&R290	16	036-13680-00	RES M/F 0805 680E 5%
R216		036-16100-00	RES M/F 0805 100K 5%	&R290	20	036-13560-00	RES M/F 0805 560E 5%
R217		036-14100-00	RES M/F 0805 1K 5%	&R290	23	036-13560-00	RES M/F 0805 560E 5%
R218		036-16150-00	RES M/F 0805 150K 5%	&R290	25	036-13560-00	RES M/F 0805 560E 5%
R219		036-14220-00	RES M/F 0805 2K2 5%	&R290	26	036-13680-00	RES M/F 0805 680E 5%
R220		036-13470-00	RES M/F 0805 470E 5%	&R290	30	036-13560-00	RES M/F 0805 560E 5%
R221		036-14150-00	RES M/F 0805 1K5 5%	&R290	35	036-13560-00	RES M/F 0805 560E 5%
R223		036-17100-00	RES M/F 0805 1M 5%	&R290	36	036-13680-00	RES M/F 0805 680E 5%
R224		036-14680-00	RES M/F 0805 6K8 5%	R291		036-10000-00	RES M/F 0805 ZERO OHM
R225		036-17100-00	RES M/F 0805 1M 5%	R292		036-14470-00	RES M/F 0805 4K7 5%
				R293		036-15470-00	RES M/F 0805 47K 5%

Ref	Var	IPN	Description	Ref	Var	IPN	Description
R294		036-14470-00	RES M/F 0805 4K7 5%	R348		036-14100-00	RES M/F 0805 1K 5%
R295		036-14270-00	RES M/F 0805 2K7 5%	R349		036-16100-00	RES M/F 0805 100K 5%
R296		036-14100-00	RES M/F 0805 1K 5%	R350		036-12220-00	RES M/F 0805 22E 5%
R297		036-14560-00	RES M/F 0805 5K6 5%	R355		036-14100-00	RES M/F 0805 1K 5%
%R298		036-16100-00	RES M/F 0805 100K 5%	R356		036-15150-00	RES M/F 0805 15K 5%
R299		036-14270-00	RES M/F 0805 2K7 5%	R357		036-15150-00	RES M/F 0805 15K 5%
R300		036-12220-00	RES M/F 0805 22E 5%	R358		036-14470-00	RES M/F 0805 4K7 5%
R301		036-15100-00	RES M/F 0805 10K 5%	R359		036-14100-00	RES M/F 0805 1K 5%
R302		036-15220-00	RES M/F 0805 22K 5%	R501		036-15100-00	RES M/F 0805 10K 5%
R303		036-14270-00	RES M/F 0805 2K7 5%	R502		036-15100-00	RES M/F 0805 10K 5%
R304		036-16100-00	RES M/F 0805 100K 5%	R503		036-14560-00	RES M/F 0805 5K6 5%
R305		036-15220-00	RES M/F 0805 22K 5%	R504		036-13330-00	RES M/F 0805 330E 5%
#R306	10	036-14150-00	RES M/F 0805 1K5 5%	R505		036-15150-00	RES M/F 0805 15K 5%
#R306	13	036-14150-00	RES M/F 0805 1K5 5%	R510		036-14150-00	RES M/F 0805 1K5 5%
#R306	15	036-14150-00	RES M/F 0805 1K5 5%	R514		036-12330-00	RES M/F 0805 33E 5%
#R306	16	036-14150-00	RES M/F 0805 1K5 5%	R515		036-12560-00	RES M/F 0805 56E 5%
#R306	20	036-14220-00	RES M/F 0805 2K2 5%	R517		036-13330-00	RES M/F 0805 330E 5%
#R306	23	036-14220-00	RES M/F 0805 2K2 5%	R518		036-12180-00	RES M/F 0805 18E 5%
#R306	25	036-14220-00	RES M/F 0805 2K2 5%	R519		036-13330-00	RES M/F 0805 330E 5%
#R306	26	036-14220-00	RES M/F 0805 2K2 5%	R520		036-16120-00	RES M/F 0805 120K 5%
#R306	30	036-14150-00	RES M/F 0805 1K5 5%	R525		036-15470-00	RES M/F 0805 47K 5%
#R306	35	036-14150-00	RES M/F 0805 1K5 5%	R530		036-15220-00	RES M/F 0805 22K 5%
#R306	36	036-14150-00	RES M/F 0805 1K5 5%	R535		036-15100-00	RES M/F 0805 10K 5%
#R307	10	036-13470-00	RES M/F 0805 470E 5%	R540		036-14220-00	RES M/F 0805 2K2 5%
#R307	13	036-13470-00	RES M/F 0805 470E 5%	R545		036-14470-00	RES M/F 0805 4K7 5%
#R307	15	036-13470-00	RES M/F 0805 470E 5%	%R550		036-14470-00	RES M/F 0805 4K7 5%
#R307	16	036-13470-00	RES M/F 0805 470E 5%	R555		036-14470-00	RES M/F 0805 4K7 5%
#R307	20	036-13150-00	RES M/F 0805 150E 5%	R560		036-13470-00	RES M/F 0805 470E 5%
#R307	23	036-13150-00	RES M/F 0805 150E 5%	R609		036-14100-00	RES M/F 0805 1K 5%
#R307	25	036-13150-00	RES M/F 0805 150E 5%	R613		036-13560-00	RES M/F 0805 560E 5%
#R307	26	036-13150-00	RES M/F 0805 150E 5%	R615		036-13100-00	RES M/F 0805 100E 5%
#R307	30	036-13470-00	RES M/F 0805 470E 5%	R617		036-10000-00	RES M/F 0805 ZERO OHM
#R307	35	036-13470-00	RES M/F 0805 470E 5%	R619		036-01100-10	RES 1 OHM 1 WATT 2512 CHIP
#R307	36	036-13470-00	RES M/F 0805 470E 5%	R621		036-01100-10	RES 1 OHM 1 WATT 2512 CHIP
R308		036-14220-00	RES M/F 0805 2K2 5%	R625		036-14100-00	RES M/F 0805 1K 5%
R309		036-15100-00	RES M/F 0805 10K 5%	R629		036-03270-10	RES 270 OHM 1 WATT 2512 CHIP
R310		036-13470-00	RES M/F 0805 470E 5%	R633		036-14680-00	RES M/F 0805 6K8 5%
R311		036-13470-00	RES M/F 0805 470E 5%	R637		036-12220-00	RES M/F 0805 22E 5%
R312		036-14100-00	RES M/F 0805 1K 5%	R638		036-12220-00	RES M/F 0805 22E 5%
R313		036-12220-00	RES M/F 0805 22E 5%	R640		036-12100-00	RES M/F 0805 10E 5%
R314		036-13470-00	RES M/F 0805 470E 5%	R641		036-14150-00	RES M/F 0805 1K5 5%
R315		036-03110-10	RES 10R 1W SMD 2512	R645		036-13470-00	RES M/F 0805 470E 5%
R322		036-12100-00	RES M/F 0805 10E 5%	R649		036-14470-00	RES M/F 0805 4K7 5%
R323		036-14150-00	RES M/F 0805 1K5 5%	R653		036-15100-00	RES M/F 0805 10K 5%
R324		036-12470-00	RES M/F 0805 47E 5%	R655		036-10000-00	RES M/F 0805 ZERO OHM
R325		036-13560-00	RES M/F 0805 560E 5%	R656		036-10000-00	RES M/F 0805 ZERO OHM
R326		036-12470-00	RES M/F 0805 47E 5%	R657		036-15100-00	RES M/F 0805 10K 5%
R327		036-14100-00	RES M/F 0805 1K 5%	R661		036-15100-00	RES M/F 0805 10K 5%
R328		036-13470-00	RES M/F 0805 470E 5%	R665		036-16100-00	RES M/F 0805 100K 5%
R329		036-12100-00	RES M/F 0805 10E 5%	R669		036-15470-00	RES M/F 0805 47K 5%
#R330	10	030-53470-20	RES FILM AI 470E 5% 0.4W 4X1.6	R673		036-16100-00	RES M/F 0805 100K 5%
#R330	13	030-53470-20	RES FILM AI 470E 5% 0.4W 4X1.6	R677		036-15470-00	RES M/F 0805 47K 5%
#R330	15	030-53470-20	RES FILM AI 470E 5% 0.4W 4X1.6	R681		036-13100-00	RES M/F 0805 100E 5%
#R330	16	030-53470-20	RES FILM AI 470E 5% 0.4W 4X1.6	R685		036-15150-00	RES M/F 0805 15K 5%
#R330	20	030-53470-20	RES FILM AI 470E 5% 0.4W 4X1.6	R689		036-12100-00	RES M/F 0805 10E 5%
#R330	23	030-53470-20	RES FILM AI 470E 5% 0.4W 4X1.6	R693		036-16100-00	RES M/F 0805 100K 5%
#R330	25	030-53470-20	RES FILM AI 470E 5% 0.4W 4X1.6	R696		036-15560-00	RES M/F 0805 56K 5%
#R330	26	030-53470-20	RES FILM AI 470E 5% 0.4W 4X1.6	R701		036-12220-00	RES M/F 0805 22E 5%
#R330	30	030-53220-20	RES FILM AI 220E 5% 0.4W 4X1.6	R702		036-17100-00	RES M/F 0805 1M 5%
#R330	35	030-53220-20	RES FILM AI 220E 5% 0.4W 4X1.6	R703		036-17100-00	RES M/F 0805 1M 5%
#R330	36	030-53220-20	RES FILM AI 220E 5% 0.4W 4X1.6	R704		036-15180-00	RES M/F 0805 18K 5%
#R331	10	030-52120-20	RES M/F 12E 5% 4X1.6 0.2"	R706		036-12100-00	RES M/F 0805 10E 5%
#R331	13	030-52120-20	RES M/F 12E 5% 4X1.6 0.2"	R708		036-17100-00	RES M/F 0805 1M 5%
#R331	15	030-52120-20	RES M/F 12E 5% 4X1.6 0.2"	R710		036-13100-00	RES M/F 0805 100E 5%
#R331	16	030-52120-20	RES M/F 12E 5% 4X1.6 0.2"	R711		036-13100-00	RES M/F 0805 100E 5%
#R331	20	030-52120-20	RES M/F 12E 5% 4X1.6 0.2"	R712		036-12100-00	RES M/F 0805 10E 5%
#R331	23	030-52120-20	RES M/F 12E 5% 4X1.6 0.2"	R713		036-10000-00	RES M/F 0805 ZERO OHM
#R331	25	030-52120-20	RES M/F 12E 5% 4X1.6 0.2"	R714		036-12100-00	RES M/F 0805 10E 5%
#R331	26	030-52120-20	RES M/F 12E 5% 4X1.6 0.2"	%R715		036-14100-00	RES M/F 0805 1K 5%
#R331	30	030-52220-20	RES FILM AI 22E 5% 0.4W 4X1.6	R717		036-14270-00	RES M/F 0805 2K7 5%
#R331	35	030-52220-20	RES FILM AI 22E 5% 0.4W 4X1.6	R718		036-16150-00	RES M/F 0805 150K 5%
#R331	36	030-52220-20	RES FILM AI 22E 5% 0.4W 4X1.6	R719		036-16150-00	RES M/F 0805 150K 5%
#R332	10	030-53470-20	RES FILM AI 470E 5% 0.4W 4X1.6	R720		036-15390-00	RES M/F 0805 39K 5%
#R332	13	030-53470-20	RES FILM AI 470E 5% 0.4W 4X1.6	R721		036-15100-00	RES M/F 0805 10K 5%
#R332	15	030-53470-20	RES FILM AI 470E 5% 0.4W 4X1.6	R722		036-15100-00	RES M/F 0805 10K 5%
#R332	16	030-53470-20	RES FILM AI 470E 5% 0.4W 4X1.6	R723		036-14270-00	RES M/F 0805 2K7 5%
#R332	20	030-53470-20	RES FILM AI 470E 5% 0.4W 4X1.6	R725		036-15390-00	RES M/F 0805 39K 5%
#R332	23	030-53470-20	RES FILM AI 470E 5% 0.4W 4X1.6	%R726		036-13100-00	RES M/F 0805 100E 5%
#R332	25	030-53470-20	RES FILM AI 470E 5% 0.4W 4X1.6	R727		036-15100-00	RES M/F 0805 10K 5%
#R332	26	030-53470-20	RES FILM AI 470E 5% 0.4W 4X1.6	R728		036-15100-00	RES M/F 0805 10K 5%
#R332	30	030-53220-20	RES FILM AI 220E 5% 0.4W 4X1.6	R734		036-13470-00	RES M/F 0805 470E 5%
#R332	35	030-53220-20	RES FILM AI 220E 5% 0.4W 4X1.6	R735		036-13470-00	RES M/F 0805 470E 5%
#R332	36	030-53220-20	RES FILM AI 220E 5% 0.4W 4X1.6	R736		036-13470-00	RES M/F 0805 470E 5%
R333		036-12470-00	RES M/F 0805 47E 5%	R742		036-13150-00	RES M/F 0805 150E 5%
R334		032-33100-10	RES M/F PWR 100E 5% 2W 12X4.5	R743		036-13150-00	RES M/F 0805 150E 5%
R335		036-12100-00	RES M/F 0805 10E 5%	R744		036-12220-00	RES M/F 0805 22E 5%
R336		036-16150-00	RES M/F 0805 150K 5%	R746		036-12220-00	RES M/F 0805 22E 5%
R337		036-16150-00	RES M/F 0805 150K 5%	R747		036-12220-00	RES M/F 0805 22E 5%
R338		036-16150-00	RES M/F 0805 150K 5%	R748		036-15470-00	RES M/F 0805 47K 5%
R339		036-16150-00	RES M/F 0805 150K 5%	R749		036-15470-00	RES M/F 0805 47K 5%
R340		036-14150-00	RES M/F 0805 1K5 5%	R750		036-12220-00	RES M/F 0805 22E 5%
R341		036-15100-00	RES M/F 0805 10K 5%	R752		036-12220-00	RES M/F 0805 22E 5%
R342		036-15100-00	RES M/F 0805 10K 5%	R753		036-17100-00	RES M/F 0805 1M 5%
R343		036-15150-00	RES M/F 0805 15K 5%	R754		036-14100-00	RES M/F 0805 1K 5%
R344		036-15470-00	RES M/F 0805 47K 5%	R756		036-15120-00	RES M/F 0805 12K 5%
R345		036-16120-00	RES M/F 0805 120K 5%	R757		036-15120-00	RES M/F 0805 12K 5%
R346		036-15100-00	RES M/F 0805 10K 5%	R758		036-14120-00	RES M/F 0805 1K2 5%
R347		036-14100-00	RES M/F 0805 1K 5%	R759		036-13330-00	RES M/F 0805 330E 5%

Ref	Var	IPN	Description	Ref	Var	IPN	Description
R760		036-13180-00	RES M/F 0805 180E 5%	T210		053-00010-17	XFMR T4030 LINE MATCH POTCORE
R762		036-13100-00	RES M/F 0805 100E 5%	T610		050-00016-50	COIL TAIT NO 650 455KHZ
R763		036-13100-00	RES M/F 0805 100E 5%				
R765		036-13680-00	RES M/F 0805 680E 5%				
R766		036-14100-00	RES M/F 0805 1K 5%				
R767		036-13680-00	RES M/F 0805 680E 5%				
R769		036-13180-00	RES M/F 0805 180E 5%				
R771		036-14820-00	RES M/F 0805 8K2 5%				
R772		036-15220-00	RES M/F 0805 22K 5%				
R774		036-14820-00	RES M/F 0805 8K2 5%				
R775		036-15180-00	RES M/F 0805 18K 5%				
R777		036-14220-00	RES M/F 0805 2K2 5%				
R780		036-12680-00	RES M/F 0805 68E 5%				
R782		036-12180-00	RES M/F 0805 18E 5%				
R784		036-13120-00	RES M/F 0805 120E 5%				
R785		036-14330-00	RES M/F 0805 3K3 5%				
R786		036-12100-00	RES M/F 0805 10E 5%				
R787		036-12100-00	RES M/F 0805 10E 5%				
R790		036-13390-00	RES M/F 0805 390E 5%				
R791		036-14100-00	RES M/F 0805 1K 5%				
R801		036-16150-00	RES M/F 0805 150K 5%				
R802		036-15470-00	RES M/F 0805 47K 5%				
R808		036-12100-00	RES M/F 0805 10E 5%				
R809		036-14470-00	RES M/F 0805 4K7 5%				
R810		036-14470-00	RES M/F 0805 4K7 5%				
R811		036-14470-00	RES M/F 0805 4K7 5%				
R812		036-14470-00	RES M/F 0805 4K7 5%				
R813		036-14470-00	RES M/F 0805 4K7 5%				
R815		036-15470-00	RES M/F 0805 47K 5%				
R816		036-16150-00	RES M/F 0805 150K 5%				
R818		036-14470-00	RES M/F 0805 4K7 5%				
R819		036-14470-00	RES M/F 0805 4K7 5%				
R821		036-15470-00	RES M/F 0805 47K 5%				
R822		036-15470-00	RES M/F 0805 47K 5%				
R824		036-14220-00	RES M/F 0805 2K2 5%				
R825		036-14220-00	RES M/F 0805 2K2 5%				
R826		036-14220-00	RES M/F 0805 2K2 5%				
R827		036-14220-00	RES M/F 0805 2K2 5%				
R828		036-14220-00	RES M/F 0805 2K2 5%				
R829		036-14220-00	RES M/F 0805 2K2 5%				
R830		036-14220-00	RES M/F 0805 2K2 5%				
R831		036-14220-00	RES M/F 0805 2K2 5%				
R832		036-14220-00	RES M/F 0805 2K2 5%				
R833		036-14220-00	RES M/F 0805 2K2 5%				
R835		036-14220-00	RES M/F 0805 2K2 5%				
R836		036-14220-00	RES M/F 0805 2K2 5%				
R837		036-14220-00	RES M/F 0805 2K2 5%				
R840		036-14220-00	RES M/F 0805 2K2 5%				
R841		036-14220-00	RES M/F 0805 2K2 5%				
R842		036-14220-00	RES M/F 0805 2K2 5%				
R843		036-14220-00	RES M/F 0805 2K2 5%				
R845		036-13470-00	RES M/F 0805 470E 5%				
R847		036-13470-00	RES M/F 0805 470E 5%				
R848		036-14470-00	RES M/F 0805 4K7 5%				
R849		036-13470-00	RES M/F 0805 470E 5%				
R850		036-13470-00	RES M/F 0805 470E 5%				
R853		036-14470-00	RES M/F 0805 4K7 5%				
R854		036-14470-00	RES M/F 0805 4K7 5%				
R855		036-14470-00	RES M/F 0805 4K7 5%				
R859		036-16150-00	RES M/F 0805 150K 5%				
R861		036-16150-00	RES M/F 0805 150K 5%				
R863		036-16150-00	RES M/F 0805 150K 5%				
R865		036-16100-00	RES M/F 0805 100K 5%				
R867		036-16100-00	RES M/F 0805 100K 5%				
R871		036-15470-00	RES M/F 0805 47K 5%				
R872		036-14470-00	RES M/F 0805 4K7 5%				
R873		036-15330-00	RES M/F 0805 33K 5%				
R874		036-14470-00	RES M/F 0805 4K7 5%				
R875		036-15470-00	RES M/F 0805 47K 5%				
R876		036-14470-00	RES M/F 0805 4K7 5%				
R877		036-14470-00	RES M/F 0805 4K7 5%				
R879		036-15100-00	RES M/F 0805 10K 5%				
RV210		040-05100-23	POT 10K LOG PCB 15MM SLOT SFT				
RV220		042-05500-05	RES PRESET SMD 50K CER 4MM SQ				
RV805		042-05200-05	RES PRESET SMD 20K CER 4MM SQ				
SK200		240-10000-05	CONN SMD SKT 8W 2R M-MATCH				
SK205		240-02020-05	SKT STEREO PHONE JACK PCB MTG				
SK310		240-02100-44	SKT COAX MINI JACK PCB MT ANG.				
SK410		240-02100-44	SKT COAX MINI JACK PCB MT ANG.				
SK501		240-04021-77	SKT JACK 1.3 PCB MT 64W				
SK502		240-04021-77	SKT JACK 1.3 PCB MT 64W				
SK503		240-04021-77	SKT JACK 1.3 PCB MT 64W				
SK504		240-04021-77	SKT JACK 1.3 PCB MT 64W				
SK505		240-04021-77	SKT JACK 1.3 PCB MT 64W				
SK513		240-04021-77	SKT JACK 1.3 PCB MT 64W				
SK522		240-04021-77	SKT JACK 1.3 PCB MT 64W				
SK531		240-04021-77	SKT JACK 1.3 PCB MT 64W				
SK532		240-04021-77	SKT JACK 1.3 PCB MT 64W				
SK533		240-04021-77	SKT JACK 1.3 PCB MT 64W				
SK534		240-04021-77	SKT JACK 1.3 PCB MT 64W				
SK535		240-04021-77	SKT JACK 1.3 PCB MT 64W				
SK805		240-10000-07	CONN SMD SKT 16W 2R M-MATCH				
SK810		240-04020-42	SKT 44 PIN SMD PLCC				
SW230		232-00010-26	SWITCH PUSH SPDT R-ANG PCB MTG				



## T857 Mechanical & Miscellaneous Parts (220-01398-04)

IPN	Legend	Description	IPN	Legend	Description
008-00014-79		S)LED 3MM RED WITH WIRE			
008-00014-80		S)LED 3MM GREEN WITH WIRE			
070-01001-00	1	D-RANGE 15 WAY COMPL T800			
219-02610-00		COAX 220MM 2 MINI PIN CRIMP Connects SK310 to SK410.			
220-01145-02	2	PCB T85X VCO			
220-01398-04	3	PCB T857 SERIES II TOP			
232-00020-26	4	BUTTON 232-00010-26 SWITCH			
240-02100-06	5	SKT COAX N TYPE PNL MTG OP-TER			
240-04020-62		SKT 2 W RECEP SHORTING LINK PL205/210/215/220.			
303-11169-04	6	CHASSIS PAINTED T800 SERIES			
303-23118-00	7	COVER A3M2247 D RANGE T855/7			
303-50074-00	8	CLIP A3M2246 SPRING CLAMP T857			
303-50078-00	9	CLIP A4M2630 SPR. CABLE CLAMP			
308-01007-01	10	HANDLE BASE STATION SERIES II			
312-01052-02	11	LID TOP T800 SER II PTND			
312-01053-02	12	LID BOTTOM T800 SER II PNTD			
316-06619-00	13	PNL FRT EX, NO EX OUT SER II			
345-00040-10	14	SCRW M3X6MM P/POZ ST BZ			
349-00020-36	15	LIM)SCREW TT M3X8m PANTORX BLK			
349-00020-43	16	SCRW T/T M4X12MM P/POZ BZ			
349-00020-45	17	SCRW T/T M4X20MM P/POZ BZ			
350-00016-42	18	SPACER 5MM HI 8MM ST 2.5MM HO			
352-00010-08	19	NUT M3 COLD FORM HEX ST BZ			
352-00010-29	20	NUT M4 NYLOC HEX			
353-00010-10	21	WSHR M3 FLAT 7MMX0.6MM ST BZ			
353-00010-13	22	WSHR M3 S/PROOF INT BZ			
353-00010-24	23	WSHR M4X8MM FLAT			
362-00010-23	24	GASKET SIL TO-220 CLIP MTG.			
362-00010-33	25	GROMMET LED MTG 3MM			
365-00011-53		LABEL 104X37MM			
365-00100-20		LABEL WHITE S/A 28X11MM			
365-01541-00		LABEL TX/RX/EX TYPE APR/SER NO			
399-00010-51		BAG PLASTIC 75X100MM			
410-01081-01		CRT T800 SERIES II			
410-01082-01		CRTN 10 T800 KIWI 423X410X360			



**replace A4 pages C6.3.37/C6.3.38 with A3 pages C6.3.37/C6.3.38**

**replace A4 pages C6.3.37/C6.3.38 with A3 pages C6.3.37/C6.3.38**

## T857 Grid Reference Index (IPN 220-01398-04)

### How To Use This Grid Reference Index

The first digit in the PCB layout reference is a "1" or "2", indicating the top or bottom side layout respectively, and the last two characters give the location of the component on that diagram.

The first digit in the circuit diagram reference is the sheet number, and the last two characters give the location of the component on that sheet.

Device	PCB	Circuit	Device	PCB	Circuit	Device	PCB	Circuit	Device	PCB	Circuit
C201	1:C1	2-B8	C304	1:F8	3-C7	C610B	1:L5	6-G8	C761	1:G3	7-J4
C202	1:C1	2-C8	C305	1:F8	3-D7	C611A	1:M6	6-H8	C762	1:G3	7-J4
C204	1:B3	2-E8	C306	1:F8	3-E6	C611B	1:M5	6-J8	C764	1:H3	7-H2
C205	1:A3	2-E8	C307	1:F8	3-E7	C615	1:M6	6-R8	C765	1:G3	7-J2
C207	1:C7	2-B6	C308	1:F8	3-G8	C616	1:M6	6-R8	C767	1:H3	7-K3
C209	1:C6	2-D6	C309	1:E8	3-A7	C623	1:N6	6-N8	C769	1:H4	7-M4
C210	1:C7	2-K0	C310	1:F5	3-B4	C625	1:M6	6-Q8	C770	1:H4	7-N4
C211	1:B7	2-F8	C311	1:F4	3-C1	C626	1:M6	6-Q8	C772	1:G4	7-M2
C213	1:B6	2-G8	C312	1:F5	3-D3	C628	1:M6	6-R8	C774	1:H4	7-P2
C215	1:B6	2-G8	C313	1:F4	3-D1	C630	1:N5	6-K5	C776	1:H4	7-N1
C217	1:C6	2-H8	C314	1:F4	3-E4	C631A	1:N5	6-M6	C782	1:G2	7-N1
C219	1:C6	2-H7	#C315	1:F4	3-E3	C634	1:M5	6-M5	C784	1:G2	7-R1
C221	1:D5	2-G6	#C316	1:E4	3-F3	C636	1:M5	6-M5	C786	1:G2	7-R1
C223	1:C5	2-J6	C317	1:F7	3-H5	C638	1:M5	6-P6	C788	1:G3	7-P0
C225	1:C3	2-K7	C318	1:F7	3-H5	C640	1:M5	6-R6	C790	1:G3	7-R0
C227	1:B4	2-K7	C319	1:F5	3-H4	C655	1:M4	6-C1	C792	1:G4	7-R0
C229	1:B3	2-L7	C320	1:E5	3-J4	C660	1:L5	6-K1	C810	1:L3	8-K8
C230	1:B4	2-J0	#C321	1:E5	3-H4	C665	1:L5	6-K1	C812	1:L2	8-F5
C232	1:A4	2-M7	#C322	1:E6	3-J3	C670	1:L5	6-L1	C813	1:K2	8-J5
C233	1:B5	2-N7	#C323	1:E6	3-L3	C673	1:L5	6-P2	C822	1:M2	8-B2
C235	1:B5	2-K5	C324	1:F7	3-M5	C677	1:L6	6-P1	C823	1:M3	8-C2
C237	1:C4	2-K5	C325	1:F7	3-N5	C681	1:L6	6-R3	C824	1:M2	8-C1
C239	1:C4	2-L4	#C326	1:E8	3-M4	C684	1:L6	6-R3	C826	1:N3	8-C0
C241	1:B4	2-M6	#C327	1:E8	3-M3	C687	1:L6	6-Q1	C827	1:N3	8-D0
C242	1:B4	2-L6	C328	1:E4	3-G1	C690	1:L6	6-R1	C828	1:N3	8-E0
C243	1:B4	2-P6	C329	1:E4	3-H2	C693	1:L6	6-R1	C830	1:N3	8-R1
C245	1:C5	2-A4	C330	1:E3	3-J2	C700	1:K4	7-A8	C838	1:N4	8-F0
C247	1:C6	2-B4	C331	1:E3	3-K2	C703	1:J3	7-B7	C841	1:N2	8-L2
C249	1:D4	2-C4	C332	1:E4	3-L2	C706	1:J2	7-B5	C844	1:M2	8-L2
C251	1:C3	2-E4	C333	1:E3	3-J0	%C707	1:K4	7-C8	C910	1:P8	9-E6
C253	1:D3	2-E3	C334	1:F8	3-C7	C708	1:J2	7-C9	C920	1:P7	9-G6
C255	1:D3	2-D2	#C335	1:E4	3-E3	C709	1:K4	7-D9	C930	1:P6	9-H6
C257	1:D3	2-F2	C336	1:F3	3-H0	C710	1:J3	7-D8			
C259	1:C6	2-J2	C337	1:E3	3-K2	C711	1:J3	7-C5	D111	1:P4	1-R1
C260	1:D8	2-H0	C340	1:E9	3-P2	C712	1:H2	7-E7	D111A	1:P5	1-Q1
C261	1:C6	2-K2	C341	1:E8	3-P1	%C713	1:H2	7-E6	%D205	1:B2	2-D9
C263	1:D6	2-L3	C342	1:E8	3-R3	C714	1:J3	7-E8	%D210	1:B2	2-D9
C265	1:D6	2-N4	#C345	1:E6	3-J4	C719	1:J3	7-F8	D220	1:B4	2-P6
C267	1:C8	2-P3	C350	1:E9	3-N2	C720	1:J3	7-F8	D220	1:B4	2-P7
&C269	1:C8	2-P3	C351	1:E9	3-N2	C722	1:J4	7-G8	D230	1:B7	2-R5
&C271	1:C8	2-Q3	C354	1:E3	3-R0	C724	1:J4	7-H6	D240	1:D4	2-C4
C273	1:C8	2-Q4	C360	1:E4	3-R8	C725	1:J4	7-J6	D240	1:D4	2-B2
C275	1:C3	2-E1	C503	1:K6	5-L9	C726	1:K4	7-J6	D250	1:D3	2-E2
C277	1:C4	2-G1	C505	1:K6	5-M6	C727	1:J3	7-J8	D250	1:D3	2-D3
C279	1:B4	2-G1	C510	1:J5	5-C0	C729	1:H3	7-M8	D260	1:C3	2-C2
C281	1:B5	2-J1	C513	1:H5	5-G2	%C733	1:H2	7-E3	D260	1:C3	2-C2
C283	1:B5	2-K0	C514	1:H5	5-G2	C735	1:J2	7-A1	D270	1:C2	2-C1
C285	1:D7	2-L0	C515	1:J5	5-F1	C736	1:J2	7-B1	D270	1:C2	2-C1
C287	1:C6	2-M1	C516	1:J5	5-H1	C740A	1:H2	7-B4	D301	1:F5	3-C3
&C289	1:C8	2-N1	C535	1:K5	5-M2	C740B	1:H2	7-B3	D302	1:F5	3-D4
C291	1:D7	2-P1	C536	1:K5	5-L2	C741A	1:H2	7-C4	D303	1:F4	3-D3
C293	1:D7	2-Q1	C537	1:K5	5-L2	C741B	1:G2	7-C3	D510	1:K6	5-K8
%C294	1:D7	2-Q0	C545	1:J5	5-K1	C742A	1:H2	7-D4	D510	1:K6	5-K8
%C295	1:C7	2-Q0	C546	1:K5	5-K0	C742B	1:H3	7-D3	D610	1:N6	6-L6
C300A	1:F9	3-J8	C550	1:K4	5-L0	C743	1:H2	7-B1	D610	1:N6	6-K6
C300B	1:F8	3-K8	C600	1:L6	6-D8	C745	1:G3	7-D1	D620	1:N4	6-B1
C301	1:E9	3-B8	C601	1:L6	6-D8	C750	1:H4	7-Q7	D620	1:N4	6-B2
C302	1:E8	3-B8	C605	1:L6	6-C8	C757	1:G4	7-F5	D630	1:M5	6-G2
C303	1:E9	3-C8	C610A	1:M5	6-F8	C759	1:G4	7-G4	D630	1:M5	6-G3

Device	PCB	Circuit	Device	PCB	Circuit	Device	PCB	Circuit	Device	PCB	Circuit
D635	1:M4	6-G3	L305	1:F4	3-E3	Q230	1:A4	2-M8	R229	1:B4	2-M7
D635A	1:M5	6-H3	L306	1:F4	3-E4	Q240	1:B7	2-Q7	R230	1:B4	2-M6
D640	1:L5	6-M2	L307	1:F4	3-F4	Q250	1:B7	2-R6	R231	1:B4	2-M6
D640	1:L5	6-M1	#L307	1:F5	3-G4	Q260	1:C4	2-F3	R232	1:B4	2-M5
D645	1:M5	6-R6	L308	1:E6	3-K4	Q270	1:D2	2-D1	R233	1:B4	2-M6
D710	1:J3	7-L8	L309	1:E6	3-K3	Q301	1:E8	3-B7	R235	1:B4	2-P6
D710	1:J3	7-L8	L310	1:E6	3-L4	Q302	1:F8	3-F7	R237	1:B7	2-Q7
D720	1:H3	7-P8	L312	1:E7	3-M4	Q304	1:E5	3-G4	R238	1:B7	2-R7
D720	1:H3	7-P8	#L313	1:E7	3-M4	Q305	2:E6	3-L4	R239	1:B8	2-R6
D730	1:H3	7-H1	L314	1:E8	3-R4	Q306	1:E4	3-G1	R241	1:B8	2-Q6
D730A	1:H3	7-F0	#L315	1:E5	3-H3	Q307	1:E3	3-H2	R242	1:B7	2-Q5
D740	1:H3	7-J2	L350	1:E9	3-N2	Q308	1:E3	3-J2	R244	1:C6	2-A5
D740A	1:H3	7-F0	L535	1:K5	5-L2	Q309	1:E3	3-J0	R245	1:D4	2-D4
D810	1:M2	8-B7	L600	1:L6	6-D8	Q310	1:E9	3-Q1	R247	1:D3	2-E4
D810A	1:M2	8-B7	L615	1:M6	6-R8	Q311	1:E8	3-Q2	R248	1:C3	2-E3
			L750	1:G3	7-Q0	Q315	1:F8	3-G8	R249	1:D4	2-F3
IC210	1:C7	2-J0	L910	1:P7	9-F7	Q505	1:K5	5-J8	R251	1:C4	2-G4
IC210	1:C7	2-Q0	L920	1:P7	9-H7	Q510	1:J5	5-D1	R253	1:C6	2-J2
IC210	1:C7	2-K2				Q520	1:J5	5-H2	R254	1:C7	2-K3
IC210	1:C7	2-L1	LINK1	2:B2	2-E9	Q530	1:J5	5-H0	R255	1:C7	2-K2
IC210	1:C7	2-C6	LINK2	2:A2	2-E8	Q540	1:K5	5-L2	R256	1:D8	2-M3
IC220	1:C6	2-P0	LK302	1:E3	3-J0	Q550	1:K5	5-L0	R257	1:D8	2-N5
IC220	1:C6	2-M3				Q610	1:L6	6-D8	R258	1:D8	2-N4
IC220	1:C6	2-D5	P100	1:P6	1-R8	Q620	1:N6	6-P8	R259	1:D6	2-P4
IC230	1:B4	2-J0	P150	1:P2	1-Q4	Q630	1:M6	6-P5	R260	1:D8	2-N4
IC230	1:B4	2-J0	P160	1:P2	1-Q4	Q660	1:L5	6-N1	R262	1:D8	2-N3
IC230	1:B4	2-L5	P170	1:P2	1-Q3	Q670	1:M6	6-Q2	R263	1:C8	2-P3
IC230	1:B4	2-N6	P204	1:D1	2-A8	Q710	1:J3	7-K8	&R264	1:C8	2-P3
IC230	1:B4	2-G1	P208	1:D1	2-A8	Q720	1:J3	7-K8	&R265	1:C8	2-P3
IC240	1:D4	2-F3	P210	1:D3	2-A3	Q730	1:H3	7-N8	&R266	1:C8	2-P3
IC250	1:D3	2-E1	P215	1:D4	2-A2	Q740	1:H3	7-N8	R267	1:C8	2-R2
IC260	1:D8	2-N0	P217	1:D4	2-A2	Q750	1:G4	7-F3	R268	1:D2	2-C0
IC260	1:D8	2-H0	P219	1:D2	2-A1	Q760	1:H3	7-H3	R269	1:D3	2-C1
IC260	1:D8	2-Q2	P225	1:D2	2-A0	Q770	1:H3	7-H1	R270	1:D3	2-D1
IC260	1:D8	2-Q3	P230	1:C5	2-B0	Q775	1:H3	7-K3	R271	1:C3	2-E1
IC260	1:D8	2-N3	P231	1:D8	2-B0	Q780	1:H3	7-K3	R272	1:C4	2-F2
IC300	1:F8	3-A0	P233	1:C1	2-R9	Q785	1:H3	7-K2	R273	1:B5	2-G2
IC300	1:F8	3-J8	P235	1:C1	2-R9	Q790	1:H3	7-L3	R274	1:C4	2-G1
IC300	1:F8	3-D7	P237	1:B7	2-R8	Q795	1:G3	7-P0	R275	1:C4	2-H0
IC610	1:L5	6-G8	P239	1:C7	2-R8	Q810	1:M2	8-E7	R277	1:B5	2-J1
IC630	1:N5	6-K5	P240	1:C7	2-R8	Q820	1:L2	8-D5	R278	1:B5	2-J0
IC640	1:M5	6-N5	P243	1:B7	2-R7	Q830	1:L2	8-D5	R279	1:B5	2-K0
IC640	1:M5	6-R6	P244	1:B7	2-R7	Q840	1:L2	8-F5	R280	1:B5	2-K0
IC640	1:M5	6-F1	P245	1:B8	2-R6	Q850	1:M2	8-G5	R282	1:D7	2-K1
IC650	1:L5	6-F4	P247	1:B8	2-R6	Q860	1:L4	8-B3	R283	1:D7	2-L1
=IC700	1:K3	7-A8	P248	1:B7	2-R6				R284	1:D7	2-L0
IC710	1:J2	7-D8	P249	1:C7	2-R5	%R150	1:P2	1-R4	R285	1:C8	2-M0
IC710	1:J2	7-C6	P251	1:C7	2-R5	R160	1:P2	1-R3	R286	1:C7	2-M0
IC710	1:J2	7-C5	P255	1:D4	2-R4	%R200	1:B2	2-C9	R287	1:D9	2-M0
IC710	1:J2	7-D6	P257	1:C2	2-R4	R201	1:B3	2-E9	R288	1:C6	2-M2
IC710	1:J2	7-D7	P259	1:B8	2-R3	R202	1:C1	2-F9	R289	1:D9	2-M0
IC710	1:J2	7-D6	P261	1:B8	2-R3	%R203	1:B3	2-C8	&R290	1:C8	2-N2
IC710	1:J2	7-C6	P263	1:B1	2-R2	R204	1:C7	2-B6	R291	1:C8	2-N1
IC720	1:J3	7-P6	P267	1:C8	2-N2	R205	1:C7	2-D6	R292	1:D8	2-Q2
IC720	1:J3	7-G0	P269	1:D8	2-P2	R206	1:B7	2-G8	R293	1:D9	2-Q2
IC720	1:J3	7-N7	P271	1:C9	2-N1	R207	1:B6	2-G8	R294	1:D9	2-Q1
IC720	1:J3	7-M7	P273	1:D9	2-P0	R208	1:B6	2-G8	R295	1:D8	2-R1
IC720	1:J3	7-K7	P275	1:D7	2-Q0	R209	1:C6	2-H8	R296	1:D7	2-P0
IC720	1:J3	7-E8	P290	1:D5	2-E0	R210	1:B6	2-H7	R297	1:D7	2-P1
IC720	1:J3	7-G0	P291	1:D5	2-G0	R211	1:B2	2-D9	%R298	1:D7	2-Q0
IC730	1:J4	7-H8	P805	1:M2	8-A7	R212	1:D4	2-F6	R299	1:C7	2-R0
IC730	1:J4	7-G7	P810	1:L3	8-A5	R213	1:C4	2-G6	R300	1:F8	3-J8
IC740	1:H2	7-D1	P820	1:L4	8-M8	R214	1:D4	2-G6	R301	1:E8	3-B8
IC750	1:H4	7-M3	P825	1:L4	8-M8	R215	1:C4	2-H6	R302	1:E8	3-A7
IC750	1:H4	7-H5	P830	1:L4	8-M8	R216	1:C3	2-K7	R303	1:E8	3-B7
IC750	1:H4	7-Q7	P835	1:L4	8-M7	R217	1:A4	2-M8	R304	1:F8	3-B8
IC820	1:L4	8-N2	P840	1:L4	8-M7	R218	1:A5	2-N7	R305	1:F8	3-C7
IC830	1:N3	8-J0				R219	1:B4	2-N8	#R306	1:F8	3-D5
IC830	1:N3	8-Q1	PL100	1:P3	1-F0	R220	1:B2	2-E9	&R307	1:F8	3-D5
IC830	1:N3	8-J0	PL205	1:C5	2-J8	R221	1:B7	2-R7	R308	1:F8	3-E7
IC830	1:N3	8-C0	PL210	1:C3	2-H4	R223	1:B4	2-K6	R309	1:F8	3-D5
IC830	1:N3	8-J1	PL215	1:C4	2-K3	R224	1:C4	2-K5	R310	1:F8	3-E6
			PL220	1:C4	2-H2	R225	1:B4	2-L5	R311	1:F8	3-F6
L300	1:F5	3-G5				R226	1:B4	2-L4	R312	1:F8	3-F8
L302	1:F5	3-C3	Q210	1:C6	2-J8	R227	1:B4	2-M4	R313	1:F8	3-F8
L303	1:F7	3-M5	Q220	1:B3	2-L7	R228	1:A2	2-E9	R314	1:F8	3-G6

<u>Device</u>	<u>PCB</u>	<u>Circuit</u>	<u>Device</u>	<u>PCB</u>	<u>Circuit</u>	<u>Device</u>	<u>PCB</u>	<u>Circuit</u>	<u>Device</u>	<u>PCB</u>	<u>Circuit</u>
R315	1:F5	3-G5	R665	1:M5	6-E2	R811	1:L2	8-E6	SK805	1:K3	8-Q8
R322	1:F4	3-C1	R669	1:M5	6-E2	R812	1:L2	8-D5	SK805	1:K3	8-Q6
R323	1:F5	3-C3	R673	1:M5	6-E0	R813	1:L2	8-D4	SK805	1:K3	8-Q8
R324	1:F4	3-C2	R677	1:M4	6-F4	R815	1:L2	8-F4	SK805	1:K3	8-Q6
R325	1:F4	3-D2	R681	1:L5	6-L2	R816	1:L2	8-F4	SK805	1:K3	8-Q9
R326	1:E4	3-G3	R685	1:L5	6-N2	R818	1:M2	8-F5	SK805	1:K3	8-Q6
R327	1:E4	3-F3	R689	1:L6	6-Q3	R819	1:M2	8-F5	SK805	1:K3	8-Q9
R328	1:F5	3-G4	R693	1:L5	6-Q1	R821	1:M4	8-B3	SK805	1:K3	8-Q7
R329	1:F7	3-H5	R696	1:L6	6-Q1	R822	1:M4	8-E3	SK805	1:K3	8-Q8
#R330	1:E5	3-J3	R701	1:K4	7-A9	R824	1:L4	8-L8	SK805	1:K3	8-Q6
#R331	1:E5	3-J4	R702	1:K4	7-C9	R825	1:L4	8-L8	SK810	1:M3	8-H5
#R332	1:E6	3-J3	R703	1:J3	7-C8	R826	1:L4	8-L8			
R333	1:E6	3-K3	R704	1:J3	7-C5	R827	1:L4	8-L7	SL201	2:D1	2-B9
R334	1:E7	3-L4	=R705	1:K3	7-A7	R828	1:L4	8-L7	SL202	2:D1	2-B8
R335	1:F7	3-M5	R706	1:H3	7-C5	R829	1:L4	8-P9	SL203	2:D2	2-B1
R336	1:E5	3-G3	R708	1:J3	7-B5	R830	1:L3	8-P9	SL204	2:D2	2-B1
R337	1:E5	3-H3	R710	1:H2	7-E7	R831	1:L3	8-P9	SL501	2:J5	5-F0
R338	1:E5	3-H3	R711	1:J2	7-B6	R832	1:L3	8-P8	SL810	1:M2	8-C7
R339	1:E5	3-H3	R712	1:J2	7-D8	R833	1:L3	8-P8			
R340	1:E4	3-G1	R713	1:J4	7-F8	R835	1:L3	8-P8	SW230	1:B8	2-A3
R341	1:E4	3-H1	R714	1:J3	7-D9	R836	1:L3	8-P8			
R342	1:E3	3-J2	%R715	1:K4	7-H6	R837	1:L3	8-P7	T210	1:B2	2-C8
R343	1:E3	3-J1	R717	1:J4	7-H7	R840	1:L3	8-P7	T610	1:L6	6-N2
R344	1:E3	3-K2	R718	1:J4	7-H7	R841	1:L3	8-P7			
R345	1:E4	3-K2	R719	1:J4	7-J6	R842	1:L3	8-P6	TP206	1:C5	2-H7
R346	1:E3	3-H0	R720	1:J3	7-K7	R843	1:L3	8-P6	TP305	1:E9	3-M2
R347	1:E3	3-J1	R721	1:J3	7-K9	R845	1:M4	8-Q5	TP601	1:N6	6-K9
R348	1:D3	3-J0	R722	1:J3	7-K8	R847	1:L2	8-Q4	TP602	1:M6	6-R9
R349	1:E3	3-J0	R723	1:H3	7-M7	R848	1:L2	8-J4	TP603	1:L5	6-J2
R350	1:E4	3-L3	R725	1:J4	7-N7	R849	1:L2	8-Q4	TP604	1:L4	6-M6
R355	1:E8	3-P2	%R726	1:J3	7-N6	R850	1:K2	8-Q4	TP607	1:L5	6-J9
R356	1:E9	3-P2	R727	1:H3	7-N9	R853	1:M4	8-N3	TP710	1:G4	7-H5
R357	1:E8	3-P1	R728	1:H3	7-N8	R854	1:M4	8-N3	TP715	1:J2	7-C6
R358	1:E8	3-Q1	R734	1:K2	7-A2	R855	1:M2	8-B0			
R359	1:E8	3-R3	R735	1:K2	7-A2	R859	1:N2	8-C1			
R501	1:K5	5-H8	R736	1:K2	7-A2	R861	1:N2	8-D1			
R502	1:K5	5-J8	R742	1:H2	7-B4	R863	1:N3	8-E1			
R503	1:K5	5-J8	R743	1:H2	7-C5	R865	1:N4	8-E0			
R504	1:K6	5-K9	R744	1:G2	7-D4	R867	1:N3	8-E1			
R505	1:K6	5-L8	R746	1:H3	7-E4	R871	1:N3	8-G2			
R510	1:K6	5-L7	R747	1:H3	7-E5	R872	1:M4	8-H1			
R514	1:K6	5-M5	R748	1:J2	7-A1	R873	1:N3	8-G1			
R515	1:H6	5-J5	R749	1:J2	7-B1	R874	1:N3	8-H0			
R517	1:G5	5-E2	R750	1:H4	7-Q7	R875	1:N3	8-G0			
R518	1:G5	5-F2	R752	1:G4	7-F5	R876	1:N3	8-H0			
R519	1:G5	5-F2	R753	1:G4	7-F3	R877	1:M2	8-K2			
R520	1:J5	5-C1	R754	1:G3	7-F3	R879	1:N2	8-L3			
R525	1:J5	5-D1	R756	1:G3	7-G5						
R530	1:J5	5-D0	R757	1:G4	7-G4	RV210	1:B7	2-F9			
R535	1:J5	5-E1	R758	1:H3	7-H4	RV220	1:A4	2-M6			
R540	1:J5	5-H2	R759	1:H3	7-H4	%RV300	1:E8	3-C5			
R545	1:J5	5-J1	R760	1:H3	7-K4	RV805	1:N4	8-F1			
%R550	1:J5	5-J2	R762	1:H3	7-K4						
%R553	1:K5	5-J1	R763	1:H3	7-L4	SK200	1:D5	2-F0			
R555	1:K5	5-K1	R765	1:H3	7-H2	SK205	1:B5	2-A5			
R560	1:K5	5-M0	R766	1:G3	7-J3	SK310	1:E8	3-N4			
R609	1:L6	6-B8	R767	1:H3	7-K2	SK410	1:M8	1-M8			
R613	1:L6	6-C8	R769	1:H3	7-K3	SK501	1:G6	5-D6			
R615	1:M5	6-F9	R771	1:H4	7-L3	SK502	1:G6	5-D5			
R617	1:M5	6-J8	R772	1:G4	7-M2	SK503	1:G6	5-D4			
R619	1:N6	6-L8	R774	1:H4	7-M3	SK504	1:G5	5-D3			
R621	1:N6	6-L8	R775	1:H4	7-N2	SK505	1:G5	5-D2			
R625	1:N6	6-L7	R777	1:H4	7-R2	SK513	1:H5	5-H3			
R629	1:N6	6-P6	R780	1:G2	7-P1	SK522	1:H6	5-K5			
R633	1:M5	6-Q8	R782	1:G3	7-P1	SK531	1:K6	5-N6			
R637	1:M5	6-K6	R784	1:G3	7-P1	SK532	1:K5	5-N5			
R638	1:M5	6-K6	R785	1:G3	7-Q1	SK533	1:K5	5-N4			
R640	1:M5	6-R6	R786	1:G2	7-R1	SK534	1:K5	5-N3			
R641	1:N5	6-L5	R787	1:G2	7-R2	SK535	1:K5	5-N2			
R645	1:N5	6-L5	R790	1:G3	7-P0	=SK710	1:K3	7-A7			
R649	1:M5	6-M5	R791	1:G3	7-Q0	SK805	1:K3	8-Q9			
R653	1:M5	6-Q5	R801	1:M2	8-D7	SK805	1:K3	8-Q7			
R655	1:L4	6-D4	R802	1:M2	8-D7	SK805	1:K3	8-Q5			
R656	1:L4	6-D4	R808	1:L2	8-B4	SK805	1:K3	8-Q7			
R657	1:M5	6-D1	R809	1:L2	8-D5	SK805	1:K3	8-Q8			
R661	1:M5	6-E3	R810	1:L3	8-D6	SK805	1:K3	8-Q7			



## Part D T858 & T859 Power Amplifiers



**Caution:** There are no user serviceable components in these power amplifiers. Refer all servicing to your nearest Tait Dealer or Customer Service Organisation.

This part of the manual is divided into five sections, as listed below. There is a detailed table of contents at the start of each section.

Section	Title
1	General Information
2	Circuit Operation
3	Initial Adjustment
4	Fault Finding
5	PCB Information





# 1 T858/859 General Information

This section provides a brief description of the T858 & T859 power amplifiers, both with and without RF power modules, along with detailed specifications and a list of types available.

The following topics are covered in this section.

Section	Title	Page
<b>1.1</b>	<b>Introduction</b>	<b>1.11</b>
<b>1.2</b>	<b>Specifications</b>	<b>1.12</b>
1.2.1	Introduction	1.12
1.2.2	General	1.12
1.2.3	Test Standards	1.13
1.2.3.1	European Telecommunication Standard	1.13
1.2.3.2	DTI CEPT Recommendation T/R-24-01	1.14
1.2.3.3	Telecommunications Industry Association	1.14
<b>1.3</b>	<b>Product Codes</b>	<b>1.15</b>
<b>1.4</b>	<b>Standard Product Range</b>	<b>1.16</b>

Figure	Title	Page
1.1	T858 Main Circuit Block Identification (Without RF Power Module)	1.4
1.2	T858 Main Circuit Block Identification (With RF Power Module)	1.6
1.3	T859 Main Circuit Block Identification (Without RF Power Module)	1.8
1.4	T859 Main Circuit Block Identification (With RF Power Module)	1.10
1.5	T858/859 Front Panel Controls	1.10



**replace A4 pages D1.3/D1.4 with A3 pages D1.3/D1.4**

**replace A4 pages D1.3/D1.4 with A3 pages D1.3/D1.4**

**replace A4 pages D1.5/D1.6 with A3 pages D1.5/D1.6**

**replace A4 pages D1.5/D1.6 with A3 pages D1.5/D1.6**

**replace A4 pages D1.7/D1.8 with A3 pages D1.7/D1.8**

**replace A4 pages D1.7/D1.8 with A3 pages D1.7/D1.8**



**replace A4 pages D1.9/D1.10 with A3 pages D1.9/D1.10**

**replace A4 pages D1.9/D1.10 with A3 pages D1.9/D1.10**

## 1.1 Introduction

The T858 and T859 are FM base station power amplifiers designed for single or multichannel operation in the 400 to 520MHz frequency range. The output power capabilities are as follows:

T858 -	10 to 60W
T859 -	20 to 110W.

The older design T858/859 PAs (without RF power modules) comprise a broad band, three stage drive amplifier whose output is split to drive two separate output stages. The outputs from these final stages are then recombined and filtered before being fed to the output socket. This type of balanced output stage offers two advantages over single ended types:

- improved intermodulation performance in the presence of high signal levels from adjacent transmitters;
- enhanced reliability: if one of the two output stages fails, the transmitter can still produce one quarter of its rated power.

The later design T858 PA (with RF power module) comprises a broad band, two stage drive amplifier whose output is filtered before being fed to the output connector.

The later design T859 PA (with RF power module) comprises a broad band, two stage drive amplifier whose output is split to drive two separate output stages. The outputs from these final stages are then recombined and filtered before being fed to the output socket. This type of balanced output stage offers two advantages over single ended types:

- improved intermodulation performance in the presence of high signal levels from adjacent transmitters;
- enhanced reliability: if one of the two output stages fails, the transmitter can still produce one quarter of its rated power.

VSWR and thermal protection are incorporated into the basic design, while monitoring and alarm signals are available for both forward and reverse power. The output power is adjustable from the front panel.

The main PCB is mounted directly on a die-cast chassis/heatsink. Extensive use is made of the latest surface mount technology.

Forced air cooling for the heatsink is provided on the T859 by a fan, which is activated whenever the transmitter is keyed. Thermal sensors will also activate the fan automatically if the internal temperature reaches an unacceptable level.

The T858 has a width of 60mm and occupies a single space in a Tait rack frame, which has the ability to accommodate up to seven standard modules. The T859 has a width of 120mm and occupies a double space.

## 1.2 Specifications

### 1.2.1 Introduction

The performance figures given are minimum figures, unless otherwise indicated, for equipment operating at standard room temperature (+22°C to +28°C) and standard test voltage (13.8V DC).

Ambient temperature is defined as the temperature of the air at the input to the cooling fan mounted on the heatsink, or immediately surrounding the heatsink if a fan is not fitted.

Where applicable, the test methods used to obtain the following performance figures are those described in the ETS specification. Refer to [Section 1.2.3](#) for details of test standards.

Details of test methods and the conditions which apply for Type Approval testing in all countries can be obtained from Tait Electronics Ltd.

### 1.2.2 General

Power Output:

T858	- Rated Power	.. 50W
	- Range Of Adjustment	.. 10 to 60W (typical)
T859	- Rated Power	.. 100W
	- Range Of Adjustment	.. 20 to 105W (typical)

Input Power: .. 1W ±300mW

Duty Cycle Rating:

T858	.. 50W continuous to +60°C ambient temperature
	.. 60W continuous to +40°C ambient temperature
T859	.. 100W continuous to +60°C ambient temperature

Intermodulation (PA with output isolator) .. -70dBc or -40dBi<sup>1</sup> with 25dB isolation & interfering signal of -30dBc

Mismatch Capability:

Ruggedness	.. refer to your nearest Tait Dealer or Customer Service Organisation
Stability	.. 5:1 VSWR (all phase angles)

1. dBi denotes the level of intermodulation product relative to the interfering signal.

## Supply Voltage:

Operating Voltage	..	10.8 to 16V DC
Standard Test Voltage	..	13.8V DC
Polarity	..	negative earth only
Polarity Protection	..	crowbar diode

## Maximum Supply Current (T858 @ 50W, T859 @ 100W):

Standby	..	50mA
Transmit - T858 without power module	..	11A
- T858 with power module	..	12.5A
- T859	..	22A

## Spurious Emissions:

Conducted	- Transmit	..	-36dBm to 1GHz -30dBm to 4GHz
	- Standby	..	-57dBm to 1GHz -47dBm to 4GHz
Radiated	- Transmit	..	-36dBm to 1GHz -30dBm to 4GHz
	- Standby	..	-57dBm to 1GHz -47dBm to 4GHz

Operating Temperature Range .. -30°C to +60°C ambient temperature

## Dimensions:

Height	..	183mm
Width - T858	..	60mm
- T859	..	120mm
Length	..	340mm

## Weight:

T858	..	3.1kg
T859	..	3.5kg

## 1.2.3 Test Standards

Where applicable, this equipment is tested in accordance with the following standards.

### 1.2.3.1 European Telecommunication Standard

#### ETS 300 086 January 1991

Radio equipment and systems; land mobile service; technical characteristics and test conditions for radio equipment with an internal or external RF connector intended primarily for analogue speech.

**ETS 300 113 March 1996**

Radio equipment and systems; land mobile service; technical characteristics and test conditions for radio equipment intended for the transmission of data (and speech) and having an antenna connector.

**ETS 300 219 October 1993**

Radio equipment and systems; land mobile service; technical characteristics and test conditions for radio equipment transmitting signals to initiate a specific response in the receiver.

**ETS 300 279 February 1996**

Radio equipment and systems; electromagnetic compatibility (EMC) standard for private land mobile radio (PMR) and ancillary equipment (speech and/or non-speech).

**1.2.3.2 DTI CEPT Recommendation T/R-24-01****Annex I: 1988**

Technical characteristics and test conditions for radio equipment in the land mobile service intended primarily for analogue speech.

**Annex II: 1988**

Technical characteristics of radio equipment in the land mobile service with regard to quality and stability of transmission.

**1.2.3.3 Telecommunications Industry Association****ANSI/TIA/EIA-603-1992**

Land mobile FM or PM communications equipment measurement and performance standards.

## 1.3 Product Codes

The three groups of digits in the T850 Series II product code provide information about the model, type and options fitted, according to the conventions described below.

The following explanation of T850 Series II product codes is not intended to suggest that any combination of features is necessarily available in any one product. Consult your nearest Tait Dealer or Customer Service Organisation for more information regarding the availability of specific models, types and options.

### Model

The Model group indicates the basic function of the product, as follows:

<u>T85X</u> -XX-XXXX	T855 receiver
	T856 25W transmitter
	T857 exciter
	T858 50W power amplifier
	T859 100W power amplifier

### Type

The Type group uses two digits to indicate the basic RF configuration of the product.

The first digit in the Type group designates the frequency range:

T85X- <u>X</u> -XXXX	'1' for 400-440MHz
	'2' for 440-480MHz
	'3' for 480-520MHz

The second digit in the Type group indicates the channel spacing:

T85X- <u>XX</u> -XXXX	'0' for wide bandwidth (25kHz)
	'3' for mid bandwidth (20kHz)
	'5' for narrow bandwidth (12.5kHz)

### Options

T85X-XX- <u>XXXX</u>	The Options group uses four digits and/or letters to indicate any options that may be fitted to the product. This includes standard options and special options for specific customers. '0000' indicates a standard Tait product with no options fitted. The large number of options precludes listing them here.
----------------------	---

## 1.4 Standard Product Range

The following table lists the range of standard T858 and T859 types (i.e. no options fitted) available at the time this manual was published. Consult your nearest Tait Dealer or Customer Service Organisation for more information.

Output Power (W)	50			100		
Frequency Range (MHz)	400-440	440-480	480-520	400-440	440-480	480-520
PA Type: T858-	10-0000	20-0000	30-0000			
PA Type: T859-				10-0000	20-0000	30-0000

You can identify the PA type by checking the product code printed on a label on the rear of the heatsink ([Figure 1.1](#) in Part A shows typical labels).



## 2 T858/859 Circuit Operation

This section provides a basic description of the circuit operation of the T858 and T859 power amplifiers.

**Note:** Where the same component has different circuit references in the T858 and T859, in this and following sections the T858 circuit reference is given first, followed by the T859 circuit reference in brackets, e.g. Q137 [Q128].

Refer to Section 5 where the parts lists, grid reference index and diagrams will provide detailed information on identifying and locating components.

The following topics are covered in this section.

Section	Title	Page
2.1	<b>Introduction</b>	2.3
2.2	<b>RF Circuitry</b>	2.4
2.3	<b>Control Circuitry</b>	2.5
2.3.1	Power Control	2.7
2.3.2	Driver Power Level	2.7
2.3.3	Thermal Protection	2.7
2.3.4	Forward And Reverse Power Alarms	2.8
2.3.5	Forward And Reverse Power Metering	2.8
2.3.6	T859 Fan Control Circuitry	2.8
2.4	<b>Power Supply &amp; Regulator Circuits</b>	2.9

Figure	Title	Page
2.1	T858 High Level Block Diagram	2.3
2.2	T859 High Level Block Diagram	2.3
2.3	T858 Control Circuitry Block Diagram	2.5
2.4	T859 Control Circuitry Block Diagram	2.6
2.5	T859 Fan Control Logic Diagram	2.8
2.6	T858/859 Power Supply & Regulator Circuitry Block Diagram	2.9



## 2.1 Introduction

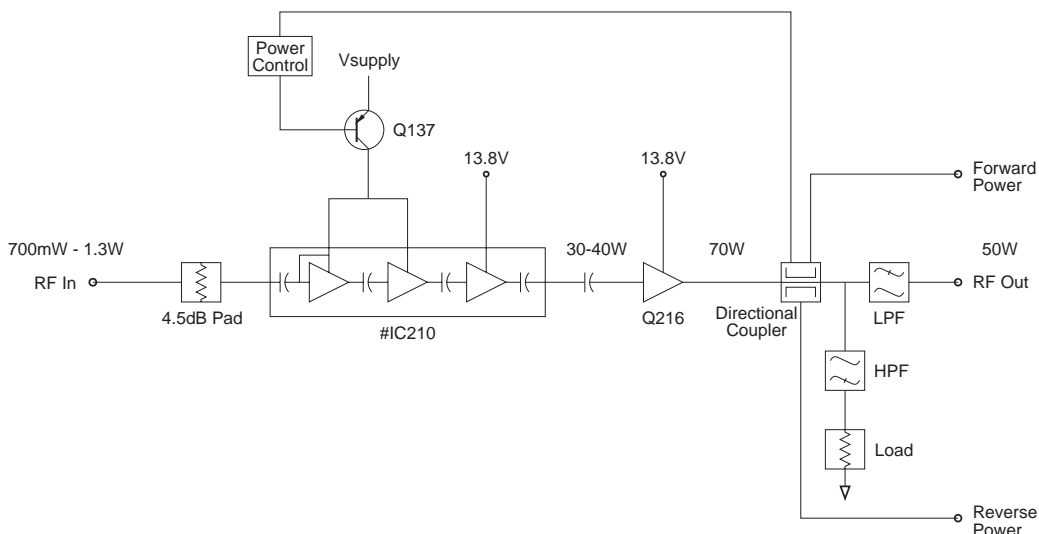

Figure 2.1 T858 High Level Block Diagram

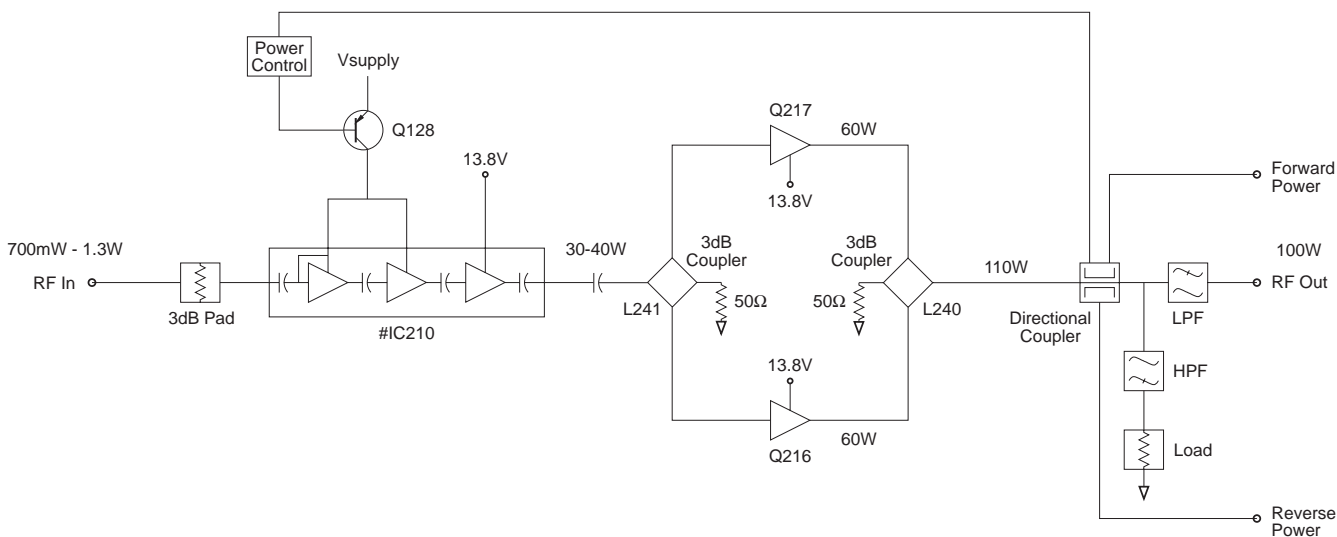

Figure 2.2 T859 High Level Block Diagram

The T858 and T859 comprise a two-stage RF power amplifier with extensive control circuitry:

- the input stage consists of a single, three-stage RF power module which increases the drive level to approx. 30W (40W typical);
- the final stage in the T858 is composed of a single transistor (Q216) which provides the rated output power; the final stage in the T859 is composed of two transistors (Q216, Q217) whose outputs are combined to provide the rated output power.

Figure 2.1 and Figure 2.2 show the configuration of each of the main circuit blocks on a functional level.

## 2.2 RF Circuitry

(Refer to [Figure 2.1](#), [Figure 2.2](#) and the RF section circuit diagrams in Section 5.)

The driver stage of the T858 consists of a three-stage RF power module (#IC210) which delivers 30-40W to the final amplifier (Q216). The output from the final is passed to the antenna socket via the harmonic filter.

The driver stage of the T859 consists of a three-stage RF power module (#IC210) which delivers 30-40W to the final transistors. The signal is split via a 3dB quadrature hybrid (L241) and used to drive the two final amplifiers (Q216, Q217). The outputs from these final stages are recombined by L240 and passed to the antenna socket via the harmonic filter.

The diplexer presents the final amplifiers with a good load at harmonic frequencies, which helps to achieve the expected harmonic attenuation in the output filter.

The directional coupler senses forward and reflected power, which is rectified (D205 & D206) and passed to the control circuitry for metering, alarm and power control purposes.

Power control is via a series pass transistor (Q137 [Q128]), which controls the supply voltage on the first two-stage of #IC210.

## 2.3 Control Circuitry

(Refer to the control section circuit diagrams in Section 5.)

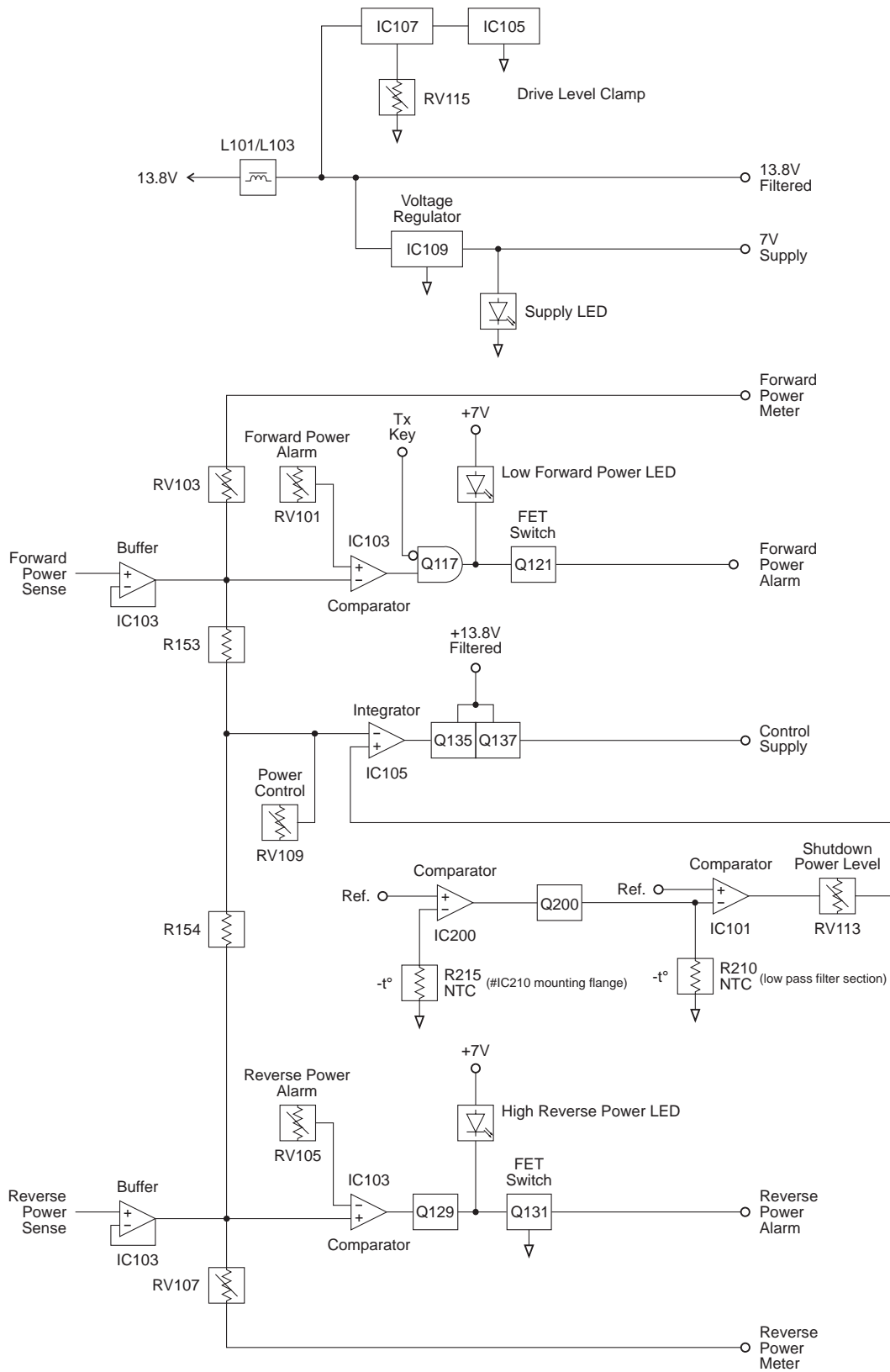

Figure 2.3 T858 Control Circuitry Block Diagram

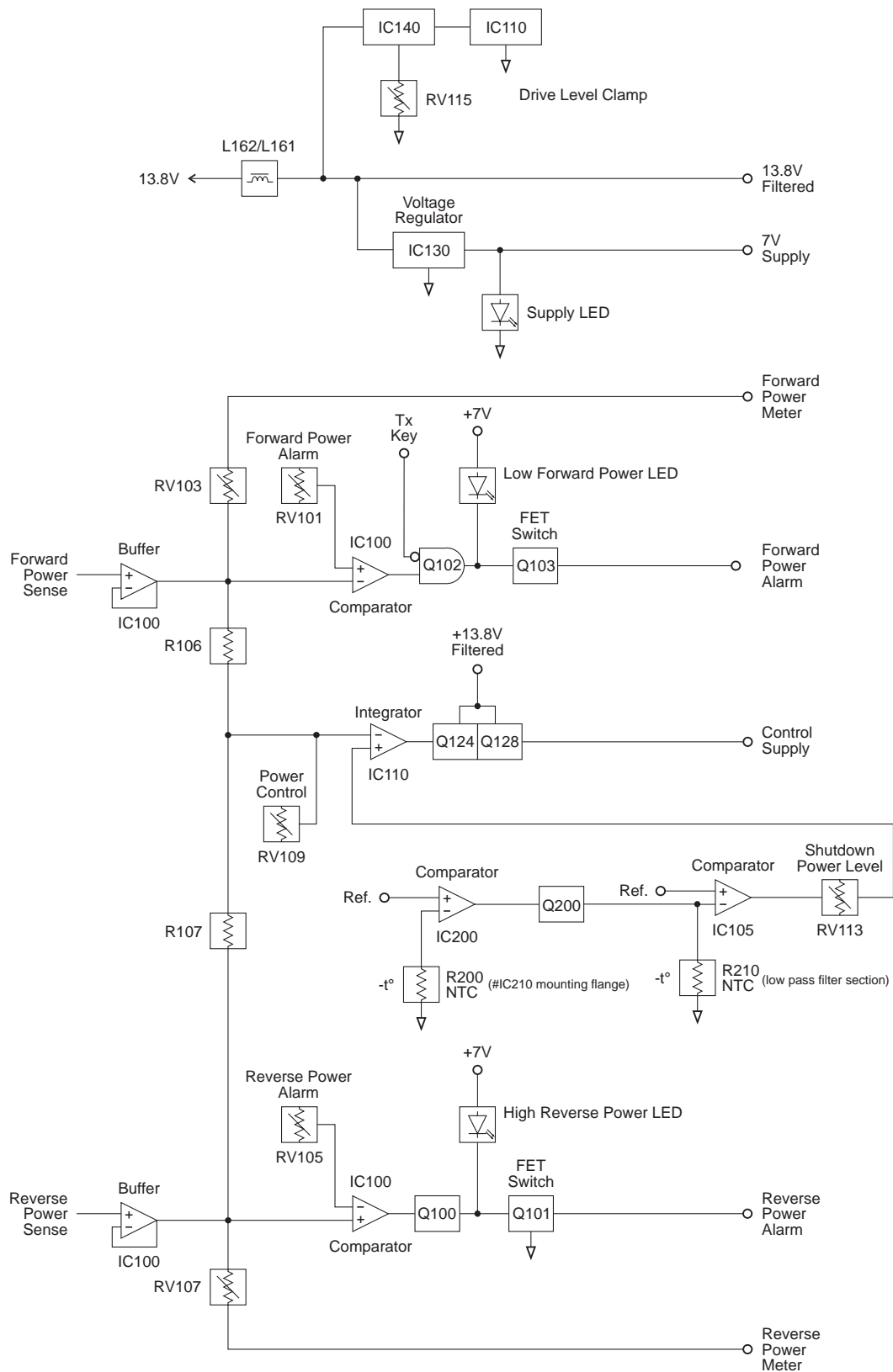

Figure 2.4 T859 Control Circuitry Block Diagram

### 2.3.1 Power Control

The DC voltages from the directional coupler representing forward and reflected power are buffered by the two voltage followers, IC103 [IC100] pins 1, 2 & 3 and pins 12, 13 & 14. Their outputs are summed at an integrator (IC105 [IC110] pins 1, 2 & 3), which drives the series pass control elements (Q135 & Q137 [Q124 & Q128]).

Forward and reflected power are summed so that, under high output VSWR, the power control turns the PA down. This is because the control loop adjusts for the same DC voltage from the directional coupler that would have been present if there were no reflected power.

### 2.3.2 Driver Power Level

The maximum output power of the T858/859 can be limited by placing a ceiling on the driver output power level using RV115 (accessible through the side cover). For example, if RV115 is set for a maximum output power of 50W, the range of adjustment using RV109 (front panel power adjust) will be 20 to 50W.



**Caution:** The driver power level clamp (RV115) is factory set to give a maximum power output at room temperature of 60W for the T858 and 110W for the T859. The unit may be damaged if this level is increased.

### 2.3.3 Thermal Protection

At excessively high temperatures, the output power will automatically reduce to a pre-set level (set by RV113), thus preventing the PA from overheating.

Ambient temperature within the PA is measured by a thermistor controlled voltage divider (R168 [R177], R210) which applies a voltage to a comparator with hysteresis (IC101 [IC105] pins 8, 9 & 10). This thermistor is located on the PCB in the low pass filter cavity.

Thermal protection is also provided for the RF power module to prevent the module itself from overheating. This protection consists of a thermistor controlled voltage divider (R203, R215 [R200]) which sets a voltage on a comparator with hysteresis (IC200 pins 1, 2 & 3). The thermistor is located on the module flange.

The output current from all comparators is summed into the power control network via RV113 so that the power level to which the PA must turn down may be set.

### 2.3.4 Forward And Reverse Power Alarms

If forward power drops below, or reverse power rises above, presettable limits, alarms may be triggered.

The alarm outputs are open drain configuration and are low under normal conditions (i.e. forward and reverse power levels are normal).

IC103 [IC100] pins 5, 6 & 7 and pins 8, 9 & 10 form comparators with thresholds adjusted via RV101 (forward power) and RV105 (reverse power) respectively. The inputs are from the forward and reverse power signals from the directional coupler, buffered by IC103 [IC100] pins 1, 2 & 3 and pins 12, 13 & 14. Thus, the power levels at which the forward and reverse power alarms are triggered are defined by RV101 and RV105 respectively.

### 2.3.5 Forward And Reverse Power Metering

Forward and reverse power signals from the two IC103 [IC100] buffers are available for metering purposes. The output currents are adjustable via RV103 (forward power) and RV107 (reverse power).

### 2.3.6 T859 Fan Control Circuitry

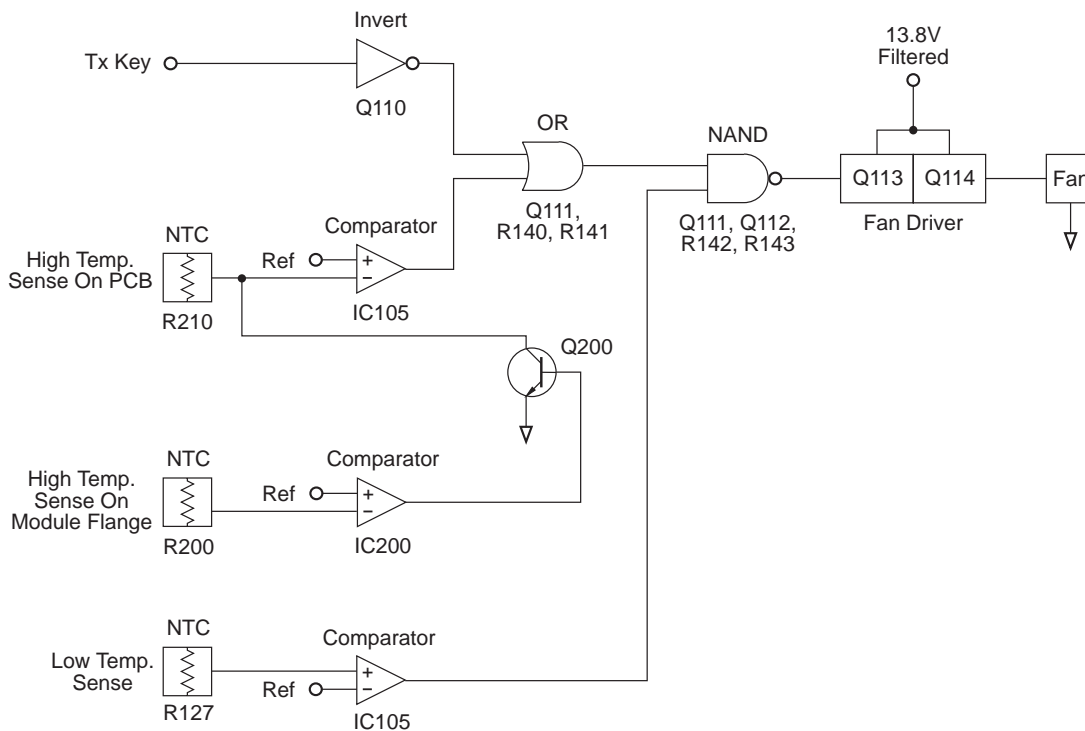

Figure 2.5 T859 Fan Control Logic Diagram



Comparator IC105 pins 12, 13 & 14 are set to switch at heatsink temperatures greater than +90°C or RF power module flange temperatures greater than +110°C, and pins 1, 2 & 3 at temperatures less than -10°C.

A logic AND function is applied to the comparator outputs by Q111 and Q112, thereby turning on the fan unconditionally (via Q113 and Q114) if the heatsink temperature exceeds +90°C or the module flange temperatures exceed +110°C.

A logic OR function is applied to comparator IC105 pins 12, 13 & 14 and Tx KEY signals, thereby turning on the fan when the transmitter is keyed and the temperature is between -10°C and +90°C (or +110°C for the module flanges).

If the temperature drops below -10°C, Q112 is turned off, preventing Q111 from activating the fan.

## 2.4 Power Supply & Regulator Circuits

(Refer to the control section circuit diagram in Section 5.)

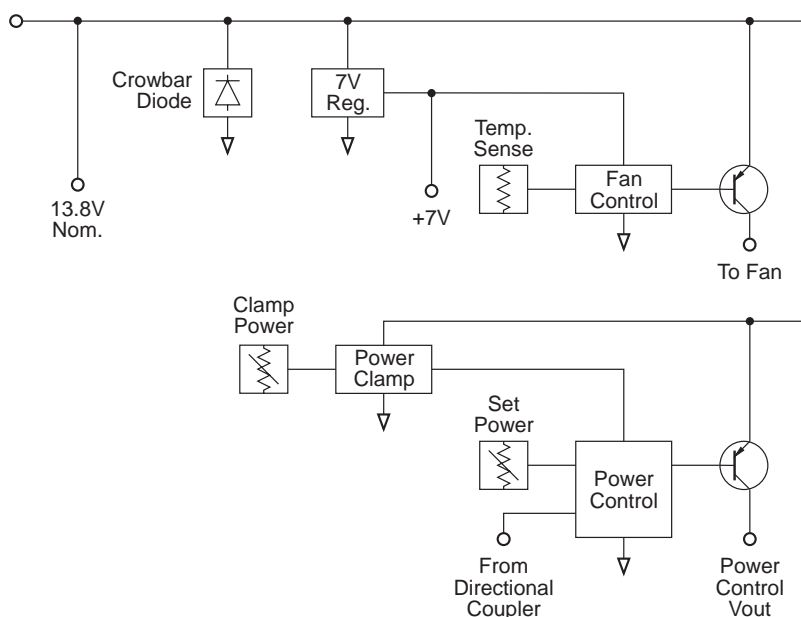

**Figure 2.6** T858/859 Power Supply & Regulator Circuitry Block Diagram

The T858/859 are designed to operate off a 10.8-16V DC supply (13.8V nominal). A 7V supply runs directly off the 13.8V rail, driving the fan control, power control and alarm circuitry.

A crowbar diode is fitted for protection against connection to a power supply of incorrect polarity. It also provides transient overvoltage protection.

**Note:** A fuse must be fitted in the power supply line for the diode to provide effective protection.



## 3 T858/859 Initial Adjustment



**Caution:** This equipment contains CMOS devices which are susceptible to damage from static charges. Refer to Section 1.2 in Part A for more information on anti-static procedures when handling these devices.

The following section describes the full adjustment procedure to be carried out before operating the T858/859.

**Note 1:** The T858/859 requires no RF tuning or alignment.

**Note 2:** Where the same component has different circuit references in the T858 and T859, in this and following sections the T858 circuit reference is given first, followed by the T859 circuit reference in brackets, e.g. Q137 [Q128].

Refer to Section 5 where the parts lists, grid reference index and diagrams will provide detailed information on identifying and locating components.

The following topics are covered in this section.

Section	Title	Page
3.1	Test Equipment Required	3.3
3.2	Shorting Links	3.3
3.3	Preliminary Checks	3.4
3.4	Setting The Output Power	3.4
3.5	High Temperature Shutdown Power Level	3.5
3.6	Remote Forward Power Meter Calibration	3.5
3.7	Remote Reverse Power Meter Calibration	3.5
3.8	Setting Alarm Levels	3.6
3.8.1	Forward Power	3.6
3.8.2	Reverse Power	3.6

Figure	Title	Page
3.1	T858/859 Test Equipment Set-up	3.3



### 3.1 Test Equipment Required

- DC power supply capable of delivering >16A (T858) or >20A (T859) at 13.8V.
- Multimeter or DMM (e.g. Fluke 77).
- RF power meter (e.g. HP 435 series or Bird Wattmeter).
- 150W 30dB attenuator (T858) or 250W 50dB attenuator (T859).
- 150W 3dB 50 ohm pad.
- 'BNC' to 'N' type adaptors (e.g. Amphenol, Greenpar).
- Appropriate trimming tools.

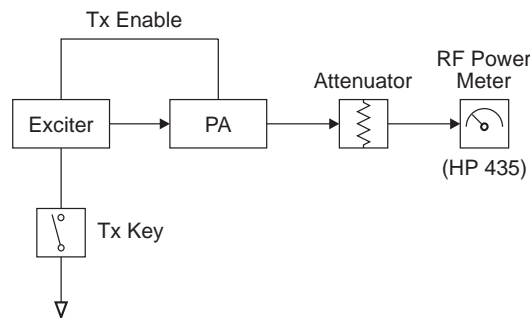

Figure 3.1 T858/859 Test Equipment Set-up



**Caution:** Do not connect attenuators or DC blocks between the T857 and T858/859 or the cyclic keying circuitry will not function correctly.

### 3.2 Shorting Links

There are seven shorting links on PL110 in the control section circuitry, as described in the table below. Ensure that these links are set as standard before starting and after completing the adjustment procedure.

Link Pins	Standard Setting	Function
1-2, 3-4, 7-8, 9-10	not linked	Not used.
5-6	not linked	Pins 5-6 are provided for simulating high operating temperatures during initial adjustment. Bridging this link shorts out R215 [R200] and R210 (NTCs), thus turning on the thermal protection circuitry. They should not be linked for normal operation.
11-12 13-14	linked	Pins 11-12 and 13-14 are provided for factory testing only. The PA will not function correctly if these settings are changed.

### 3.3 Preliminary Checks

Check for short circuits between the positive rail and earth.

Set up the test equipment as in Figure 3.1.

Connect the T858/859 to a 13.8V DC supply.

Check that the quiescent current is <50mA.

To key the transmitter, earth the key line (pin 13) on the exciter.

Check that the power supply is still at 13.8V under load.

Check that the regulated power control supply is approximately 7V.

**Note:** The output power and alarm levels should be set with the side cover on. If the cover is removed for other adjustment procedures, make a final check of the output power and alarm levels with the side cover on.

### 3.4 Setting The Output Power



**Caution:** If the high temperature shutdown power level has not yet been set or is unknown, check that the unit does not overheat while setting the output power.

**Note 1:** Cables and connectors can easily cause a power loss of several watts if either too long or poorly terminated. Always use the shortest possible leads (or connectors instead of leads) between the T858/859 and power meter set-up.

**Note 2:** You will need appropriate extension leads if you wish to carry out the adjustment procedures with the T858/859 withdrawn from the rack in the latched position. Alternatively, disconnect and withdraw the T858/859 and reconnect it behind the rack.

**Note 3:** The actual power used may be limited by regulatory requirements.

Connect the exciter output to the PA input via a thru-line wattmeter with a 5W full scale reading. Special BNC/N leads will be required.

Ensure that PL110 pins 11-12 and 13-14 are linked, and all other pins are not linked.

Connect an RF power meter to the PA output via a 30dB pad.

Set RV109 [%RV109] (front panel power control) and RV115 (driver power clamp) fully clockwise.

Key on the drive source.

Check that the power output exceeds:

T858 - 60W  
T859 - 120W.

**Note:** The side cover access hole for the driver power clamp (RV115) is covered with a tamper-proof sticker. The clamp has been factory set to 60W (T858)/110W (T859) maximum output power and *should not normally need adjustment*. If the output power level is low, check that the high temperature shutdown circuit has not activated by verifying that IC101 [IC105] pin 8 is low.

Adjust RV115 to reduce the maximum power output to:

T858 - 60W  
T859 - 110W.

Adjust RV109 [%RV109] to set the power output to the required level (e.g. 50W for the T858, 100W for the T859).

### 3.5 High Temperature Shutdown Power Level

Set RV109 [%RV109] (front panel power control) to the required output power.

Simulate high operating temperatures by placing a shorting link on PL110 pins 5-6 (*do not* use either of the links from PL110 pins 11-12 or 13-14 to do this).

Adjust RV113 (shutdown power level) for an output power of:

T858 - 20W  
T859 - 40W.

Remove the shorting link from PL110 pins 5-6 to return the PA to normal operation.

### 3.6 Remote Forward Power Meter Calibration

If a remote meter is connected, adjust RV103 (forward power meter calibration) for the remote reading to agree with the RF power meter reading.

### 3.7 Remote Reverse Power Meter Calibration

If a remote meter is connected, connect a 50 ohm 3dB pad (with the output open circuit) to the PA output.

Apply RF drive and Tx-Key.

Adjust RV107 (reverse power meter calibration) for a quarter of the forward power reading.

## 3.8 Setting Alarm Levels

**Note:** If forward and reverse power metering is being used, set up their calibration (Section 3.6 and Section 3.7) before setting the alarm levels.

### 3.8.1 Forward Power

Power up the T858/859 and adjust RV109 [%RV109] (front panel power control) so that the output power is at the alarm level required (e.g. 40W if the T858 normally operates at 50W).

Adjust RV101 (forward power alarm set) so that the forward power alarm LED lights.

Check the alarm level setting by adjusting the power up and down and observing the alarm LED. A few watts hysteresis can be expected.

Readjust RV109 [%RV109] for the normal operating level.

**Note:** Remote indication is available at pin 3 of D-range 1.

### 3.8.2 Reverse Power

Power up the T858/859 and adjust RV109 [%RV109] (front panel power control) for the normal operating power level.

Place a known mismatch of the required value (e.g. 3:1 VSWR) and adjust RV105 (reverse power alarm set) so that the reverse power alarm LED lights.

**Example:** A VSWR of 3:1 can be simulated by connecting an unterminated 3dB pad (50W) to the PA output. This will result in a return loss of 6dB.

**Note:** Remote indication is available at pin 4 of D-range 1.



## 4 T858/859 Fault Finding



**Caution:** This equipment contains CMOS devices which are susceptible to damage from static charges. Refer to Section 1.2 in Part A for more information on anti-static procedures when handling these devices.

The following test procedures and fault finding flow charts may be used to help locate a hardware problem, however they are by no means a complete fault finding procedure. If you still cannot trace the fault after progressing through them in a logical manner, contact your nearest Tait Dealer or Customer Service Organisation. If necessary, you can get additional technical help from Customer Support, Radio Systems Division, Tait Electronics Ltd, Christchurch, New Zealand (full contact details are on page 2).

**Note:** Where the same component has different circuit references in the T858 and T859, in this and following sections the T858 circuit reference is given first, followed by the T859 circuit reference in brackets, e.g. Q137 [Q128].

Refer to Section 5 where the parts lists, grid reference index and diagrams will provide detailed information on identifying and locating components.

The following topics are covered in this section.

Section	Title	Page
4.1	Visual Checks	4.3
4.2	Shorting Links	4.3
4.3	Component Checks	4.3
4.4	DC Checks	4.4
4.5	RF Checks	4.4
4.5.1	T858	4.4
4.5.2	T859	4.5
4.6	Fault Finding Charts	4.9
4.6.1	T858 PA	4.9
4.6.2	T859 PA	4.10
4.6.3	T858 Power Control	4.11
4.6.4	T859 Power Control	4.12
4.6.5	T859 Fan Control Circuitry	4.13
4.7	Replacing RF Power Transistors	4.14
4.8	Replacing RF Power Modules	4.16
4.9	Removing The PCB From The Heatsink	4.17

<b>Figure</b>	<b>Title</b>	<b>Page</b>
4.1	T858/859 Test Break Point Location	4.7
4.2	Typical Capacitor Positioning On T858/859 RF Power Transistors	4.14

## 4.1 Visual Checks

Remove the side cover from the T858/859 and inspect the PCB for damaged or broken components, paying particular attention to the surface mounted devices (SMDs). Also check for defective solder joints.

Refer to Section 4.7, Section 4.8, Section 4.9 and Section 3 of Part A for more details on repair and replacement of components.

## 4.2 Shorting Links

There are seven shorting links on PL110 in the control section circuitry, as described in the table below. Ensure that these links are set as standard before starting and after completing the adjustment procedure.

Link Pins	Standard Setting	Function
1-2, 3-4, 7-8, 9-10	not linked	Not used.
5-6	not linked	Pins 5-6 are provided for simulating high operating temperatures during initial adjustment. Bridging this link shorts out R215 [R200] and R210 (NTCs), thus turning on the thermal protection circuitry. They should not be linked for normal operation.
11-12 13-14	linked	Pins 11-12 and 13-14 are provided for factory testing only. The PA will not function correctly if these settings are changed.

## 4.3 Component Checks

If you suspect a transistor is faulty, you can assess its performance by measuring the forward and reverse resistance of the junctions. Unless the device is completely desoldered, first make sure that the transistor is not shunted by some circuit resistance (e.g. a base choke). Use a good quality EVM (e.g. Fluke 75) for taking the measurements (or a 20k ohm/V or better multimeter, using only the medium or low resistance ranges).



**Caution:** Before operating the PA, replace any RF base chokes removed while making measurements.

The collector current drawn by multi-junction transistors is a further guide to their performance.

If an IC is suspect, the most reliable check is to measure the DC operating voltages. Due to the catastrophic nature of most IC failures, the pin voltages will usually be markedly different from the recommended values in the presence of a fault. The recommended values can be obtained from either the circuit diagram or the component data catalogue.

## 4.4 DC Checks

**Note:** No RF power is to be applied during these checks.

Check that +13.8V is present on the collectors of Q216 (T858) or Q216 and Q217 (T859). Make this measurement when the transmitter is not keyed.

Check that approximately 8-13.8V is present on pin 2 of #IC210 (the level is dependent on RV115 being set to maximum).

Check that +13.8V is present at pin 4 of IC100.

Check that approximately +12V is present at pin 8 of IC110 (the level is dependent on RV115 being set to maximum).

Check that +7.0V is present at the output of regulator IC130.

## 4.5 RF Checks

### 4.5.1 T858

The T858 PA Fault Finding Chart (Section 4.6.1) provides a systematic approach for locating a fault in the RF circuitry. Use this chart in conjunction with Figure 4.1, which shows the locations of the 50Ω input and output test points for RF module #IC210 and RF transistor Q216.

Device	Input Connection	Output Connection
#IC210	input BNC connector or SK201	C249
Q216	C249	C250

**Note 1:** Use good quality 50Ω coax for the "flying" test leads.

**Note 2:** Ensure each output is terminated in a 50Ω load of the correct power rating.

For problems with the power control circuitry, refer to the T858 Power Control Fault Finding Chart (Section 4.6.3).

## 4.5.2 T859

The T859 PA Fault Finding Chart (Section 4.6.2) provides a systematic approach for locating a fault in the RF circuitry. Use this chart in conjunction with Figure 4.1, which shows the locations of the 50Ω input and output test points for RF module #IC210 and RF transistors Q216 and Q217.

Device	Input Connection	Output Connection
#IC210	input BNC connector or SK201	C274
Q216 & Q217	L241	C250, C262

**Note 1:** Use good quality 50Ω coax for the "flying" test leads.

**Note 2:** Ensure each output is terminated in a 50Ω load of the correct power rating.

For problems with the power control circuitry, refer to the T859 Power Control Fault Finding Chart (Section 4.6.4).



## replace A4 pages D4.7/D4.8 with A3 pages D4.7/D4.8

*Figure 4.1 T858/859 Test Break Point Location*

unavailable at time of publication



**replace A4 pages D4.7/D4.8 with A3 pages D4.7/D4.8**



## 4.6 Fault Finding Charts

### 4.6.1 T858 PA

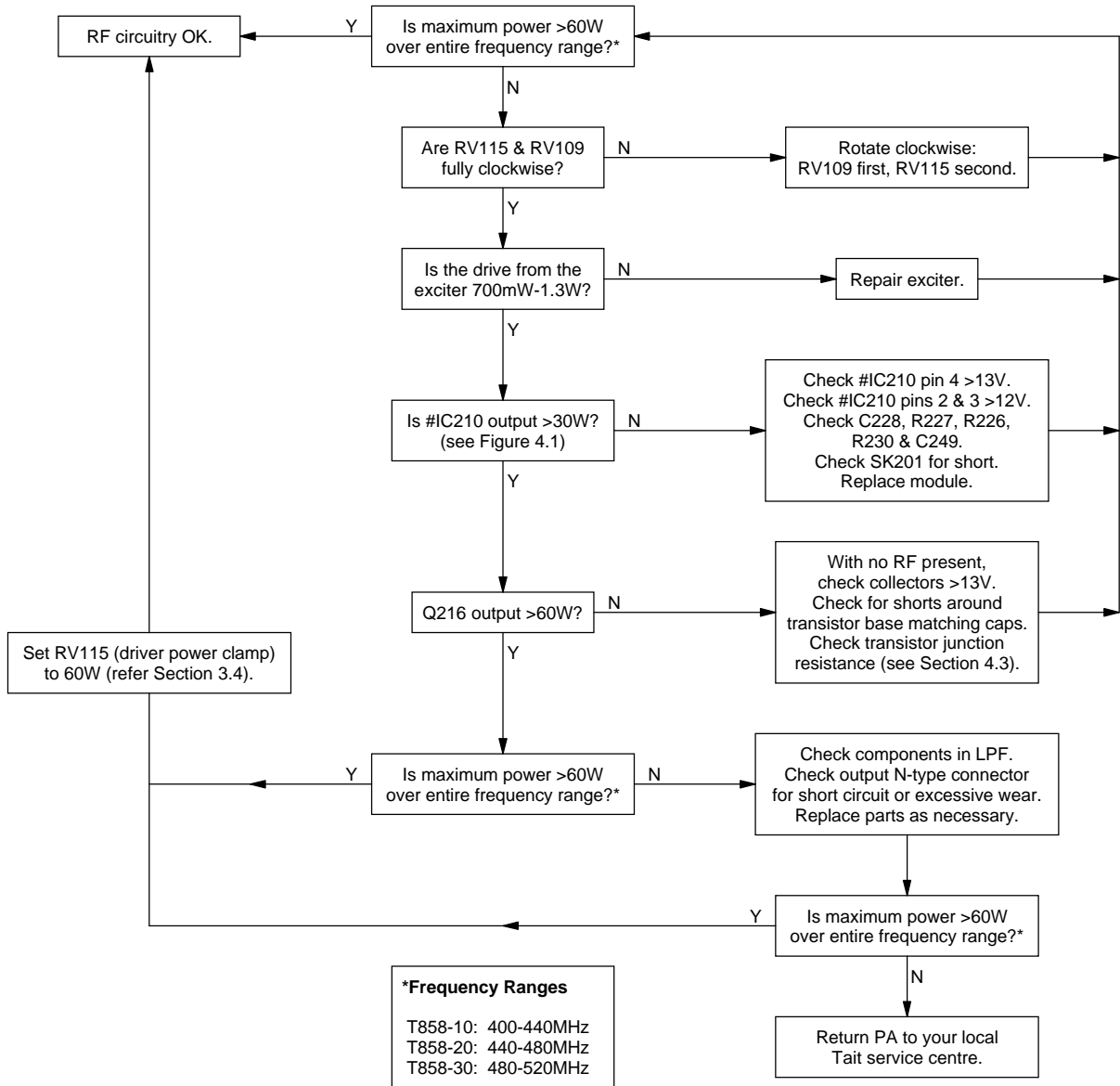

4.6.2 T859 PA

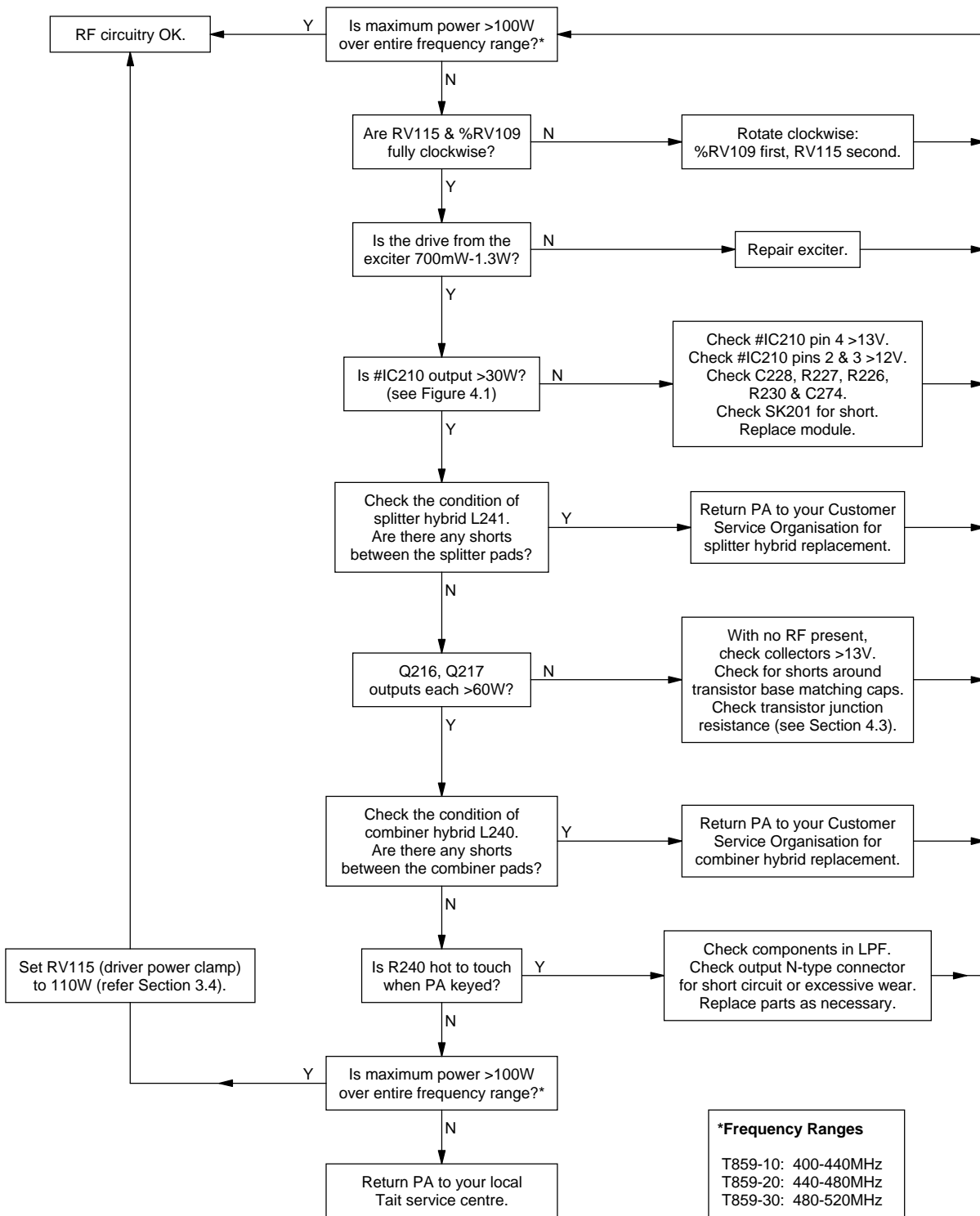

### 4.6.3 T858 Power Control

Approximate voltages (@ 480MHz) under normal operating conditions:

Forward & Reverse Power Measurement	Output Power	
	20W	50W
forward power at IC100 pin 14	1.8V	2.9V
reverse power at IC100 pin 1	0.6V	0.6V

#### Caution

The following voltage checks are all done with RV115 (driver power clamp) set to maximum. When these tests are finished, reset RV115 to 60W.

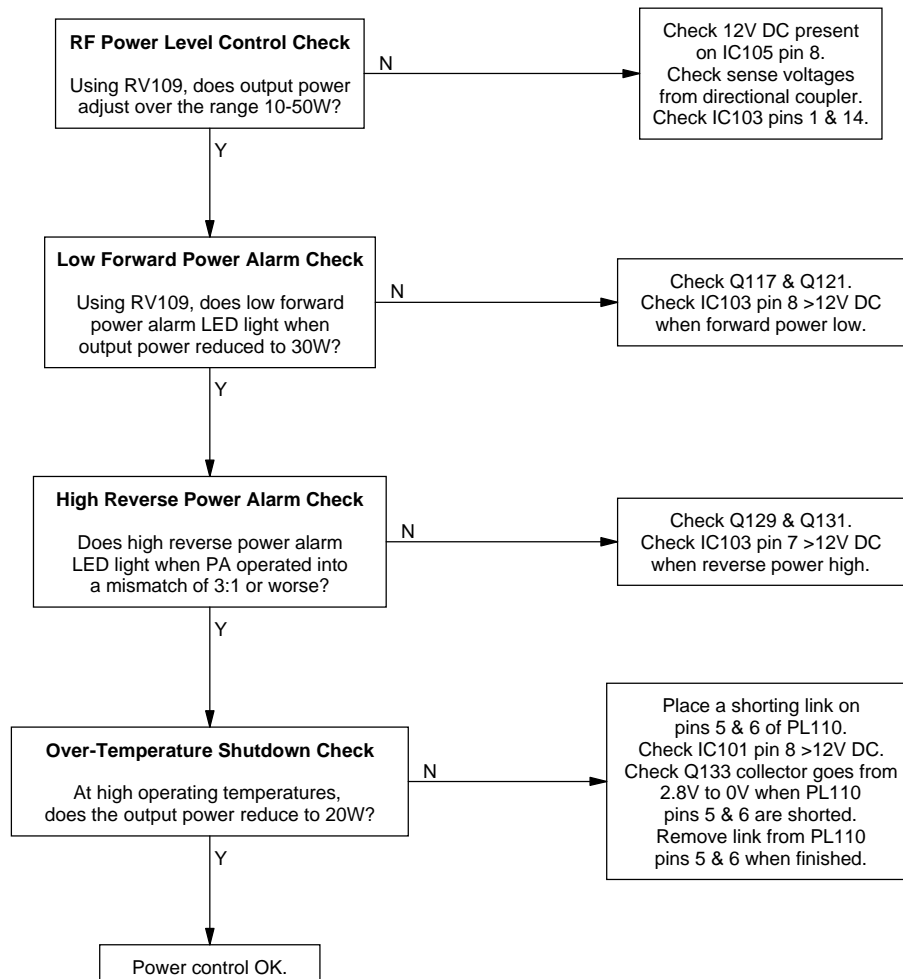

### 4.6.4 T859 Power Control

Approximate voltages (@ 480MHz) under normal operating conditions:

Forward & Reverse Power Measurement	Output Power	
	40W	100W
forward power at IC100 pin 14	2.5V	4.2V
reverse power at IC100 pin 1	0.6V	0.6V

**Caution**

The following voltage checks are all done with RV115 (driver power clamp) set to maximum. When these tests are finished, reset RV115 to 110W.

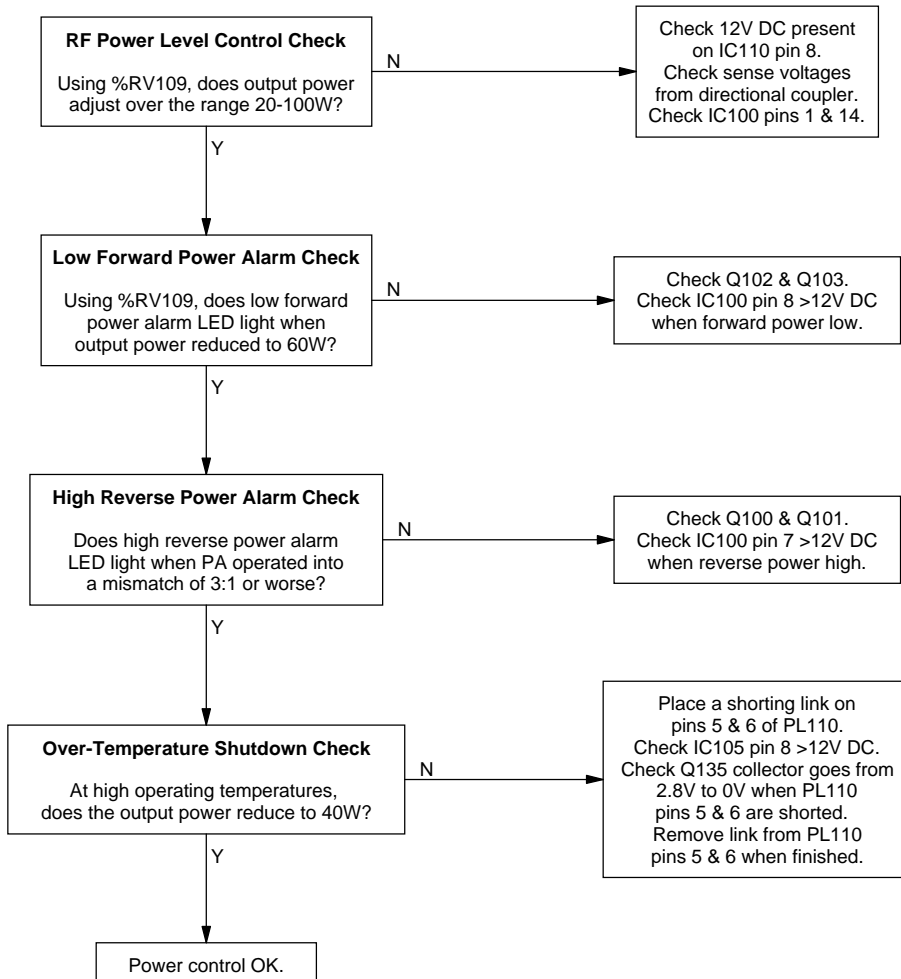

## 4.6.5 T859 Fan Control Circuitry

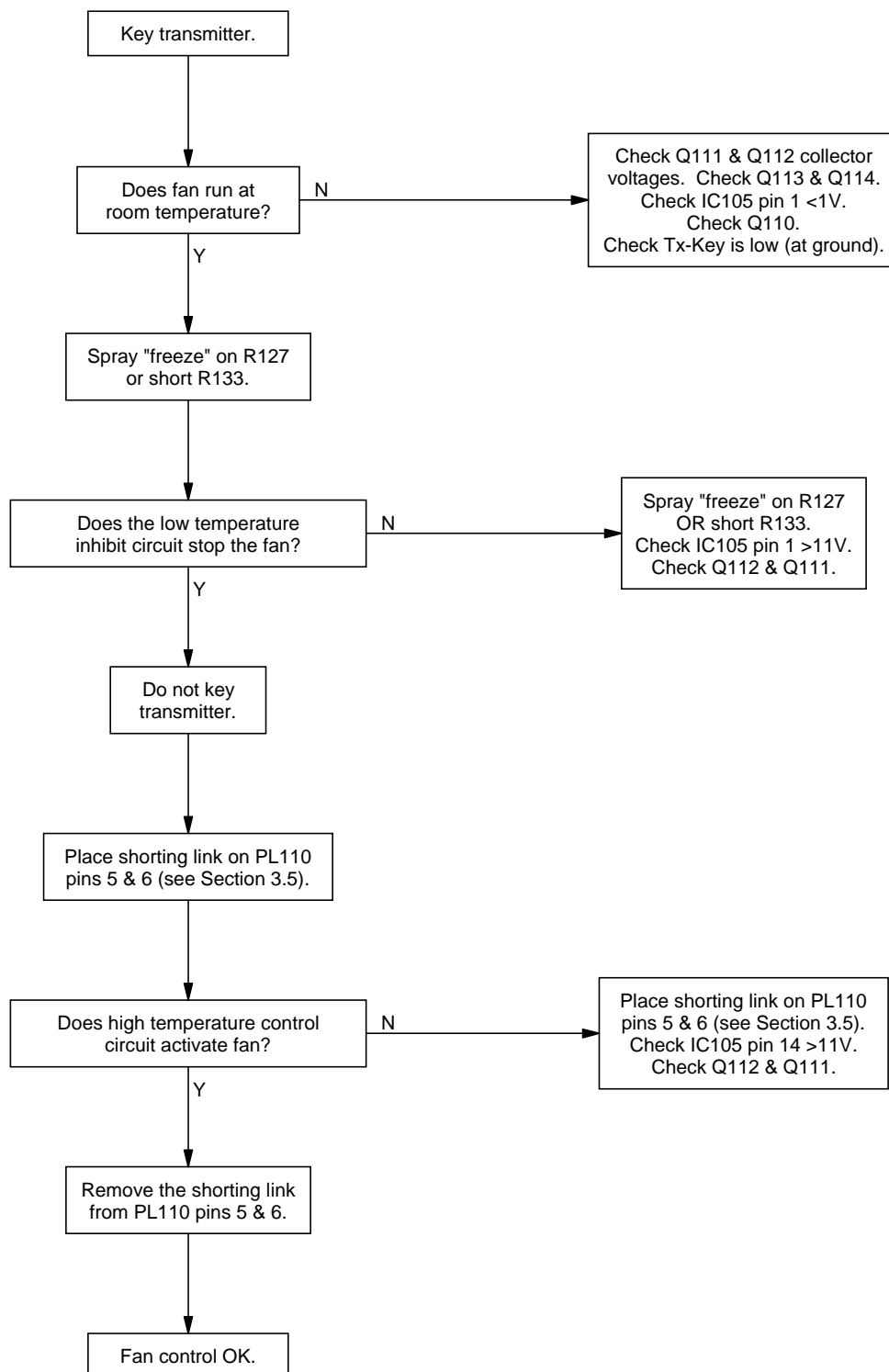

## 4.7 Replacing RF Power Transistors



**Caution:**

Failure to comply with the following procedure can result in failure of the device due to poor heatsinking, or worse, can endanger the health of the assembler if the beryllium oxide die carrier is smashed during assembly.



**Caution:**

As the location of certain components in the PA is critical to performance, it is important that any components removed or disturbed are refitted in *exactly* the same position.

Before attempting to remove a transistor, note the position, type and value of each capacitor. Measure the distance between each capacitor and the transistor body to the nearest 0.5mm (measurement "A" in Figure 4.2) so that it can be replaced in *exactly* the same position. These measurements are shown for the T858, however the same procedure applies for the T859.



**Caution:**

Do not apply too much heat or pressure to the PCB pads and tracks as you may damage them or lift them from the PCB, causing permanent damage to the PA.

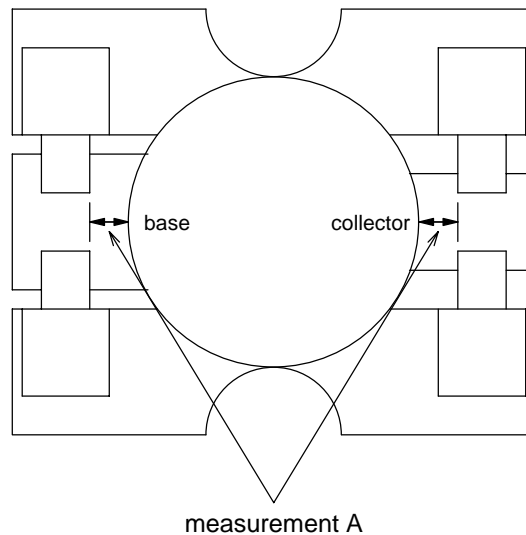

**Figure 4.2 Typical Capacitor Positioning On T858/859 RF Power Transistors (Not To Scale)**

Desolder and remove the capacitors from around the transistor.

Remove the two mounting screws, then desolder and remove the two solder tags.

Desolder the transistor tabs by heating with a soldering iron and lifting away from the PCB with a screwdriver or thin stainless steel spike, then remove the device.

Remove any excess solder from the PCB pads with solder wick.

Trim the tabs of the replacement transistor so that the device sits neatly on the PCB pads provided.

Lightly tin the underside of the transistor tabs. Remove any excess solder to leave a thin, even layer on the tabs.

Apply a small amount of heatsink compound (Dow-Corning 340 or equivalent) to the transistor mounting surface. Sufficient compound should be used to ensure an even film over the entire mounting surface.

Place the transistor on the PCB in the correct orientation and ensure the tabs are flush to the surface.

Solder all transistor tabs to the PCB.

Refit the solder tags and mounting screws. Tighten the screws to a torque of 90N.cm/8in.lbf.

Replace each capacitor in exactly the same position as noted previously.

## 4.8 Replacing RF Power Modules



**Caution:** Follow these instructions carefully, otherwise the module can fail because of poor heatsinking or cracked substrates.

Desolder the module legs by heating with a soldering iron and lifting away from the PCB with a screwdriver or thin stainless steel spike.

Undo the module screws and remove the thermistor assembly.

Desolder and remove both earth tags.

Gently lift the module away from the heatsink.

**Note:** The module may be stuck down quite firmly with heatsink compound. You may need to carefully prise it away from the heatsink with a small screwdriver. Keep the heatsink compound clean while the module is detached.

Apply a small amount of heatsink compound (Dow-Corning 340 or equivalent) to the replacement module mounting surface. Use enough compound to ensure an even film over the entire mounting surface.

Reposition the module in the correct orientation and ensure it is well pasted to the heatsink.

Replace the earth tags and thermistor assembly in their original positions and hand-tighten the screws, ensuring the tags and thermistor remain in place. Alternately tighten each screw evenly, finally torquing them down to 56N.cm/5in.lbf. with an accurate torque driver.



**Caution:** It is essential that you apply the correct torque to these screws to allow the module flange to expand and contract under temperature cycling. Also, do not solder any module legs before torquing down otherwise the device may be broken.

Solder the earth tags and all module legs to the PCB.



## 4.9 Removing The PCB From The Heatsink

**Note:** This is a lengthy procedure and should be considered only after all other checks have been carried out. There are no components on the bottom of the PCB.

Remove the harmonic filter shield lid.

**T859 Only:** Desolder the power feed to the fan from the PCB.

Remove the 50 ohm output N-type connector by unscrewing it from the heatsink casting and desoldering it from the PCB.

Unplug the 50 ohm input coaxial cable from the PCB, unscrew the BNC connector from the heatsink, and remove the connector and cable.

Desolder the positive and negative power feed wires from the D-range PCB.

Disconnect the ribbon cable from the D-range PCB.

Remove the two screws securing the D-range connector and PCB to the heatsink and withdraw the assembly from the heatsink.

Remove the mounting screws for the TO-220 devices:

T858	Q137
T859	Q128, R231 and R240.

Remove the two screws securing the power module (#IC210).

Remove the mounting screws for the power transistors:

T858	Q216
T859	Q216 and Q217.

Remove the PCB retaining screws:

T858	13
T859	17.

Push the three LEDs out of their front panel grommets.

Lift the PCB gently from the heatsink to gain access to the underside of the board.

**Note:** R231, R240 and #IC210 may be stuck down with heatsink compound. You may need to carefully prise them away from the heatsink with a small screwdriver.



**Caution:** Keep the heatsink compound clean while the PCB is detached. Any objects caught in the heatsink compound underneath the device which prevent effective earthing and/or heatsinking may cause the device to fail.



**Caution:** Do not operate the PA with the PCB detached as the heatsink is used for earthing and heat dissipation.

To replace the PCB, reverse the order of removal, taking care that the wiring is correctly positioned and not 'pinched'.

Make sure that the heatsink compound has stayed clean, and that the insulating pad for Q137 [Q128] is not damaged.

If you have difficulty refitting the LEDs, try pushing the body of the LED back into the grommet with a thin screwdriver or spike.

## T859 Parts List (IPN 220-01422-03)

### How To Use This Parts List

The components listed in this parts list are divided into two main types: those with a circuit reference (e.g. C2, D1, R121, etc.) and those without (miscellaneous and mechanical).

Those with a circuit reference are grouped in alphabetical order and then in numerical order within each group. Each component entry comprises three or four columns: the circuit reference, variant (if applicable), IPN and description. A number in the variant column indicates that this is a variant component which is fitted only to the product type listed. Static sensitive devices are indicated by an (S) at the start of the description column.

The miscellaneous and mechanical section lists the variant and common parts in IPN order. Where possible, a number in the legend column indicates their position in the mechanical assembly drawing.

The Parts List Amendments box below lists component changes that took place after the parts list and diagrams in this section were compiled. These changes (e.g. value changes, added/deleted components, etc.) are listed by circuit reference in alphanumeric order and supersede the information given in the parts list or diagrams. Components without circuit references are listed in IPN order.

### Parts List Amendments

C142	Changed from 4n7 (IPN 015-24470-08) to 33nF (IPN 015-25330-08) to improve cyclic keying (711105).	
C147	Changed from 1nF (IPN 015-24100-08) to 33nF (IPN 015-25330-08) to improve cyclic keying (711104).	
C173	Deleted - not required for circuit performance (711141).	
#C247, #C273	T859-10-0000: changed from 15pF (IPN 015-02150-03) to 12pF (IPN 015-02120-03)	} to reduce the maximum output power and reduce excessive power at the top of the frequency band (711138/39/40).
C249, C268	Changed from 15pF (IPN 015-02150-03) to 12pF (IPN 015-02120-03)	
#C256, #C257, #C269, #C270	T859-10-0000: changed from 39pF (IPN 029-02390-02) to 47pF (IPN 029-02470-02) T859-20-0000: changed from 33pF (IPN 029-02330-02) to 39pF (IPN 029-02390-02) T859-20-0000: changed from 22pF (IPN 029-02220-02) to 33pF (IPN 029-02330-02)	
D101	Changed from MR750/SR2607 (IPN 001-00011-60) to MR2520L (IPN 001-00012-90) to provide overvoltage transient suppression (750087/88/89/90/91/92 and 711129).	
R144	Changed from 1k (IPN 036-14100-10) to 18k (IPN 036-15180-00) to improve cyclic keying (711104).	
R158	Changed from 22k (IPN 036-15220-00) to 18k (IPN 036-15180-00) to improve cyclic keying (711105).	
R168	Changed from 2k7 (IPN 036-14270-10) to 4k7 (IPN 036-14470-10) to reduce the maximum output power and reduce excessive power at the top of the frequency band (711138/39/40).	
349-00020-36	The two M3x8 Torx screws which secure the module into the rack frame have been replaced by M3x8 Pozidriv screws (IPN 349-00020-55) (750101/2/3/5/6).	

**Parts List Amendments - Continued**

This page is provided for entering future amendments to the parts list.

Ref	Var	IPN	Description	Ref	Var	IPN	Description
C100		015-23100-01	CAP CER 0805 100P 5% NPO 50V	#C247	10	015-02150-03	CAP CER 15P 5% 500V HIQ GRH111
C101		015-23100-01	CAP CER 0805 100P 5% NPO 50V	#C247	20	015-02120-03	CAP CER 12P 5% 500V HIQ GRH111
C102		015-23100-01	CAP CER 0805 100P 5% NPO 50V	#C247	30	015-02120-03	CAP CER 12P 5% 500V HIQ GRH111
C103		015-23100-01	CAP CER 0805 100P 5% NPO 50V	C249		015-02150-03	CAP CER 15P 5% 500V HIQ GRH111
C104		015-23100-01	CAP CER 0805 100P 5% NPO 50V	C250		015-03100-03	CAP CER 100P 5% 500VHIQ GRH111
C105		015-23100-01	CAP CER 0805 100P 5% NPO 50V	#C252	10	029-02560-02	CAP MICA 5 CASE 56P 5%
C107		015-23100-01	CAP CER 0805 100P 5% NPO 50V	#C252	20	029-02560-02	CAP MICA 5 CASE 56P 5%
C108		015-23100-01	CAP CER 0805 100P 5% NPO 50V	#C252	30	029-02470-02	CAP MICA 5 CASE 47P 5%
C109		014-07100-02	CAP TANT CHIP 1U0 3.2 X 1.6MM	#C253	10	029-02560-02	CAP MICA 5 CASE 56P 5%
C110		015-23100-01	CAP CER 0805 100P 5% NPO 50V	#C253	20	029-02560-02	CAP MICA 5 CASE 56P 5%
C111		015-23100-01	CAP CER 0805 100P 5% NPO 50V	#C253	30	029-02470-02	CAP MICA 5 CASE 47P 5%
C112		015-24470-08	CAP CER 0805 4N7 10% X7R 50V	C254		029-02150-02	CAP MICA 5 CASE 15P 5%
C113		015-23100-01	CAP CER 0805 100P 5% NPO 50V	#C256	10	029-02390-02	CAP MICA 5 CASE 39P 5%
C114		015-23100-01	CAP CER 0805 100P 5% NPO 50V	#C256	20	029-02330-02	CAP MICA 5 CASE 33P 5%
C115		015-23100-01	CAP CER 0805 100P 5% NPO 50V	#C256	30	029-02220-02	CAP MICA 5 CASE 22P 5%
C116		015-24470-08	CAP CER 0805 4N7 10% X7R 50V	#C257	10	029-02390-02	CAP MICA 5 CASE 39P 5%
C117		015-23100-01	CAP CER 0805 100P 5% NPO 50V	#C257	20	029-02330-02	CAP MICA 5 CASE 33P 5%
C119		015-23100-01	CAP CER 0805 100P 5% NPO 50V	#C257	30	029-02220-02	CAP MICA 5 CASE 22P 5%
C120		015-23100-01	CAP CER 0805 100P 5% NPO 50V	C258		015-03100-02	CAP CER HIQ1210 100P 5%NPO200V
C121		015-23100-01	CAP CER 0805 100P 5% NPO 50V	C259		015-06100-08	CAP CER 1206 100N 10% X7R 50V
C122		015-23100-01	CAP CER 0805 100P 5% NPO 50V	C260		014-07470-04	CAP TANT SMD 4U7 50V 20%
C123		015-23100-01	CAP CER 0805 100P 5% NPO 50V	C261		015-03100-02	CAP CER HIQ1210 100P 5%NPO200V
C124		015-23100-01	CAP CER 0805 100P 5% NPO 50V	C262		015-03100-03	CAP CER 100P 5% 500VHIQ GRH111
C125		015-23100-01	CAP CER 0805 100P 5% NPO 50V	C263		029-02150-02	CAP MICA 5 CASE 15P 5%
C126		015-23100-01	CAP CER 0805 100P 5% NPO 50V	#C264	10	029-02560-02	CAP MICA 5 CASE 56P 5%
C127		015-23100-01	CAP CER 0805 100P 5% NPO 50V	#C264	20	029-02560-02	CAP MICA 5 CASE 56P 5%
C128		015-23100-01	CAP CER 0805 100P 5% NPO 50V	#C264	30	029-02470-02	CAP MICA 5 CASE 47P 5%
C129		015-23100-01	CAP CER 0805 100P 5% NPO 50V	#C265	10	029-02560-02	CAP MICA 5 CASE 56P 5%
C130		015-23100-01	CAP CER 0805 100P 5% NPO 50V	#C265	20	029-02560-02	CAP MICA 5 CASE 56P 5%
C131		015-23100-01	CAP CER 0805 100P 5% NPO 50V	#C265	30	029-02470-02	CAP MICA 5 CASE 47P 5%
C132		015-23100-01	CAP CER 0805 100P 5% NPO 50V	C268		015-02150-03	CAP CER 15P 5% 500V HIQ GRH111
C133		015-06100-08	CAP CER 1206 100N 10% X7R 50V	#C269	10	029-02390-02	CAP MICA 5 CASE 39P 5%
#C134		014-18220-02	LJCAP TANT SMD 22U 20% 35V	#C269	20	029-02330-02	CAP MICA 5 CASE 33P 5%
C136		015-23100-01	CAP CER 0805 100P 5% NPO 50V	#C269	30	029-02220-02	CAP MICA 5 CASE 22P 5%
C137		015-26100-08	CAP CER 0805 100N 10% X7R 50V	#C270	10	029-02390-02	CAP MICA 5 CASE 39P 5%
C138		015-25220-08	CAP CER 0805 22N 10% X7R 50V	#C270	20	029-02330-02	CAP MICA 5 CASE 33P 5%
C139		015-23100-01	CAP CER 0805 100P 5% NPO 50V	#C270	30	029-02220-02	CAP MICA 5 CASE 22P 5%
C140		015-23100-01	CAP CER 0805 100P 5% NPO 50V	C272		014-07470-04	CAP TANT SMD 4U7 50V 20%
C141		015-23100-01	CAP CER 0805 100P 5% NPO 50V	#C273	10	015-02150-03	CAP CER 15P 5% 500V HIQ GRH111
C142		015-24470-08	CAP CER 0805 4N7 10% X7R 50V	#C273	20	015-02120-03	CAP CER 12P 5% 500V HIQ GRH111
C143		015-23100-01	CAP CER 0805 100P 5% NPO 50V	#C273	30	015-02120-03	CAP CER 12P 5% 500V HIQ GRH111
C144		015-23100-01	CAP CER 0805 100P 5% NPO 50V	C274		015-03100-03	CAP CER 100P 5% 500VHIQ GRH111
C145		015-24470-08	CAP CER 0805 4N7 10% X7R 50V	C275		015-24470-08	CAP CER 0805 4N7 10% X7R 50V
C146		015-23100-01	CAP CER 0805 100P 5% NPO 50V	C276		015-23150-01	CAP CER 0805 150P 5% NPO 50V
C147		015-24100-08	CAP CER 0805 1N 10% X7R 50V	#C277	10	029-02120-01	CAP MICA 10 CASE 12P 5%
C148		015-23100-01	CAP CER 0805 100P 5% NPO 50V	#C277	20	029-02100-01	CAP MICA 10 CASE 10P 10%
C149		015-25100-08	CAP CER 0805 10N 10% X7R 50V	#C277	30	029-02100-01	CAP MICA 10 CASE 10P 10%
C150		015-23100-01	CAP CER 0805 100P 5% NPO 50V	#C278	10	029-02120-01	CAP MICA 10 CASE 12P 5%
C151		015-27100-10	CAP CER 0805 1M+80-20% Y5V 16V	#C278	20	029-02100-01	CAP MICA 10 CASE 10P 10%
C152		015-23100-01	CAP CER 0805 100P 5% NPO 50V	#C278	30	029-02100-01	CAP MICA 10 CASE 10P 10%
C153		015-23100-01	CAP CER 0805 100P 5% NPO 50V	#C280	10	029-01560-02	CAP MICA 5 CASE 5P6 5%
C154		015-23100-01	CAP CER 0805 100P 5% NPO 50V	#C280	20	029-01470-02	CAP MICA 5 CASE 4P7 5%
C156		015-23100-01	CAP CER 0805 100P 5% NPO 50V	#C280	30	029-01470-02	CAP MICA 5 CASE 4P7 5%
C157		015-23100-01	CAP CER 0805 100P 5% NPO 50V	C282		015-21220-01	CAP CER 0805 2P2+-1/4P NPO 50V
C158		015-23100-01	CAP CER 0805 100P 5% NPO 50V	#C283	10	015-21470-01	CAP CER 0805 4P7+-1/4P NPO 50V
C159		015-26100-08	CAP CER 0805 100N 10% X7R 50V	#C283	20	015-21390-01	CAP CER 0805 3P9+-1/4P NPO 50V
C161		015-24470-08	CAP CER 0805 4N7 10% X7R 50V	#C283	30	015-21390-01	CAP CER 0805 3P9+-1/4P NPO 50V
C162		014-18220-02	LJCAP TANT SMD 22U 20% 35V	C284		015-23150-01	CAP CER 0805 150P 5% NPO 50V
C163		014-18220-02	LJCAP TANT SMD 22U 20% 35V	#C285	10	015-21390-01	CAP CER 0805 3P9+-1/4P NPO 50V
C164		015-24100-08	CAP CER 0805 1N 10% X7R 50V	#C285	20	015-21330-01	CAP CER 0805 3P3+-1/4P NPO 50V
C166		015-06100-08	CAP CER 1206 100N 10% X7R 50V	#C285	30	015-21330-01	CAP CER 0805 3P3+-1/4P NPO 50V
C167		015-06100-08	CAP CER 1206 100N 10% X7R 50V	C286		015-21220-01	CAP CER 0805 2P2+-1/4P NPO 50V
C168		014-08100-00	CAP TANT CHIP 10M 16VW +-20%	C287		015-24470-08	CAP CER 0805 4N7 10% X7R 50V
C169		015-06100-08	CAP CER 1206 100N 10% X7R 50V	C293		029-03100-02	CAP MICA 5 CASE 100P 5%
C172		015-26100-08	CAP CER 0805 100N 10% X7R 50V				
C173		014-07100-02	CAP TANT CHIP 1U0 3.2 X 1.6MM	D101		001-00011-60	S) DIODE MR750 OR SR2607
C174		015-25100-08	CAP CER 0805 10N 10% X7R 50V	D105		001-10000-70	S) DIODE SMD BAV70 D-SW SOT23
C175		015-26100-08	CAP CER 0805 100N 10% X7R 50V	D110		001-10000-70	S) DIODE SMD BAV70 D-SW SOT23
C176		014-07470-03	LJ CAP TANT SMD 4U7 35V 20%	D112		008-00014-79	S)LED 3MM RED WITH WIRE
C177		015-25100-08	CAP CER 0805 10N 10% X7R 50V	D114		008-00014-79	S)LED 3MM RED WITH WIRE
C178		015-22470-01	CAP CER 0805 47P 5% NPO 50V	D115		001-10000-70	S) DIODE SMD BAV70 D-SW SOT23
C197		015-25100-08	CAP CER 0805 10N 10% X7R 50V	D120		001-10000-70	S) DIODE SMD BAV70 D-SW SOT23
C198		015-25100-08	CAP CER 0805 10N 10% X7R 50V	D190		008-00014-80	S)LED 3MM GREEN WITH WIRE
C200		015-24470-08	CAP CER 0805 4N7 10% X7R 50V	D205		001-10066-00	DIODE SCHOTTKY HSMS2815
C201		015-23100-01	CAP CER 0805 100P 5% NPO 50V	D206		001-10066-00	DIODE SCHOTTKY HSMS2815
C202		015-23100-01	CAP CER 0805 100P 5% NPO 50V				
C203		015-24470-08	CAP CER 0805 4N7 10% X7R 50V	IC100		002-10003-24	S) IC SMD 324 4X O-AMP SO14
C204		015-23100-01	CAP CER 0805 100P 5% NPO 50V	IC105		002-10003-24	S) IC SMD 324 4X O-AMP SO14
C205		015-24100-08	CAP CER 0805 1N 10% X7R 50V	IC110		002-10006-62	S)IC SMD LMC662CM 2X O-AMP
C206		015-23100-01	CAP CER 0805 100P 5% NPO 50V	IC130		002-10003-17	(S) IC LM317L REG SO-8 100MA
C207		015-23100-01	CAP CER 0805 100P 5% NPO 50V	IC140		002-12951-00	IC SMD LP2951CM ADJ VLTGE REG
C208		015-23100-01	CAP CER 0805 100P 5% NPO 50V	IC200		002-10003-58	S) IC SMD LM358 DUAL O-AMP
C209		015-24470-08	CAP CER 0805 4N7 10% X7R 50V	#IC210	10	004-00687-62	MODULE M68762L 400-450MHZ 30W
C210		015-23100-01	CAP CER 0805 100P 5% NPO 50V	#IC210	20	004-00687-61	MODULE M68762H 440-490MHZ 30W
C211		015-24100-08	CAP CER 0805 1N 10% X7R 50V	#IC210	30	004-00687-63	MODULE M68762SH 470-520MHZ 30W
C214		015-23680-08	CAP CER 0805 680P 10% X7R 50V				
C215		015-06100-08	CAP CER 1206 100N 10% X7R 50V	L120		065-10004-20	BEAD FE SMD CBD 4.6/3/3-4S2
C218		015-03100-06	CAP CER 1210 100P NPO500VGRM42	L161		065-10004-20	BEAD FE SMD CBD 4.6/3/3-4S2
C219		014-07470-04	CAP TANT SMD 4U7 50V 20%	L162		065-10004-20	BEAD FE SMD CBD 4.6/3/3-4S2
C220		015-06100-08	CAP CER 1206 100N 10% X7R 50V	L200		056-10330-02	(L) IND SMD 330NH
C221		015-03100-03	CAP CER 100P 5% 500VHIQ GRH111	L201		056-10330-02	(L) IND SMD 330NH
C222		015-03100-03	CAP CER 100P 5% 500VHIQ GRH111	L202		056-10330-02	(L) IND SMD 330NH
C223		015-06100-08	CAP CER 1206 100N 10% X7R 50V	L203		056-10330-02	(L) IND SMD 330NH
C224		014-07470-04	CAP TANT SMD 4U7 50V 20%	L208		065-10004-20	BEAD FE SMD CBD 4.6/3/3-4S2
C225		015-06100-08	CAP CER 1206 100N 10% X7R 50V	L209		052-08340-40	COIL A/W 4T/4.0MM SMD 0.8MM
C226		015-03100-03	CAP CER 100P 5% 500VHIQ GRH111	L210		052-08340-40	COIL A/W 4T/4.0MM SMD 0.8MM
C227		015-23100-01	CAP CER 0805 100P 5% NPO 50V	L211		065-10004-20	BEAD FE SMD CBD 4.6/3/3-4S2
C228		015-03100-02	CAP CER HIQ1210 100P 5%NPO200V	L212		052-08340-40	COIL A/W 4T/4.0MM SMD 0.8MM

Ref	Var	IPN	Description	Ref	Var	IPN	Description
%L213		056-10330-02	(L) IND SMD 330NH	R137		036-15150-00	RES M/F 0805 15K 5%
L235		051-00005-60	IND HAIRPIN 10MM TALL T859	R138		036-15150-00	RES M/F 0805 15K 5%
L237		052-08340-50	COIL A/W 5T/4.0MM SMD 0.8MM	R139		036-14390-10	RES M/F 0805 3K9 1%
L238		065-10009-20	BEAD FER SMD BDS 3/3/8.9-4S2	R140		036-15150-00	RES M/F 0805 15K 5%
L239		052-08340-50	COIL A/W 5T/4.0MM SMD 0.8MM	R141		036-14390-10	RES M/F 0805 3K9 1%
L240		051-00649-10	HYBRID COUPLER 0.4-1G 100W 3DB	R142		036-14820-10	RES M/F 0805 8K2 1%
L241		051-00649-10	HYBRID COUPLER 0.4-1G 100W 3DB	R143		036-14680-10	RES M/F 0805 6K8 1%
L242		052-08340-50	COIL A/W 5T/4.0MM SMD 0.8MM	R144		036-14100-10	RES M/F 0805 1K 1%
L243		051-00005-60	IND HAIRPIN 10MM TALL T859	%R145		036-10000-00	RES M/F 0805 ZERO OHM
L246		052-08340-50	COIL A/W 5T/4.0MM SMD 0.8MM	R146		036-13470-00	RES M/F 0805 470E 5%
L247		065-10009-20	BEAD FER SMD BDS 3/3/8.9-4S2	R147		036-13220-10	RES 0805 220E 1%
L253		056-10330-02	(L) IND SMD 330NH	R148		036-10000-00	RES M/F 0805 ZERO OHM
#L254	10	052-08340-20	COIL A/W 2T/4.0MM SMD 0.8MM	R149		036-14560-00	RES M/F 0805 5K6 5%
#L254	20	052-08335-20	COIL A/W 2T/3.5MM SMD 0.8MM	R150		036-14470-10	RES M/F 0805 4K7 1%
#L254	30	052-08335-20	COIL A/W 2T/3.5MM SMD 0.8MM	R151		036-13220-10	RES 0805 220E 1%
#L255	10	052-08345-20	COIL A/W 2T/4.5MM SMD 0.8MM	R152		036-13100-10	RES M/F 0805 100E 1%
#L255	20	052-08340-20	COIL A/W 2T/4.0MM SMD 0.8MM	R153		036-14220-00	RES M/F 0805 2K2 5%
#L255	30	052-08340-20	COIL A/W 2T/4.0MM SMD 0.8MM	R154		036-14220-00	RES M/F 0805 2K2 5%
#L256	10	052-08340-20	COIL A/W 2T/4.0MM SMD 0.8MM	R155		036-15100-10	RES M/F 0805 10K 1%
#L256	20	052-08335-20	COIL A/W 2T/3.5MM SMD 0.8MM	R156		036-14180-00	RES M/F 0805 1K8 5%
#L256	30	052-08335-20	COIL A/W 2T/3.5MM SMD 0.8MM	R157		036-15470-10	RES M/F 0805 47K 1%
L257		056-10330-02	(L) IND SMD 330NH	R158		036-15220-00	RES M/F 0805 22K 5%
#L258	10	052-08325-10	COIL A/W 1T/2.5MM SMD 0.8MM	R159		036-13470-00	RES M/F 0805 470E 5%
#L258	20	052-08320-10	COIL A/W 1T/2.0MM SMD 0.8MM	R160		036-03180-10	RES 180R 1W SMD 2512
#L258	30	052-08320-10	COIL A/W 1T/2.0MM SMD 0.8MM	R161		036-15100-10	RES M/F 0805 10K 1%
L259		052-08320-10	COIL A/W 1T/2.0MM SMD 0.8MM	R162		036-15100-10	RES M/F 0805 10K 1%
L260		052-08335-10	COIL A/W 1T/3.5MM SMD 0.8MM	R163		036-13100-10	RES M/F 0805 100E 1%
LINK200		051-00640-02	LNK 65.5 COP STPL C/W SLCN SLV	R164		036-03180-10	RES 180R 1W SMD 2512
P200		356-00010-26	PIN TRACK HARWIN FOR 1.6MM PCB	R165		036-03100-02	RES 100E 1206 200V 250MW RC01
P201		356-00010-26	PIN TRACK HARWIN FOR 1.6MM PCB	R166		036-15100-10	RES M/F 0805 10K 1%
P250		356-00010-26	PIN TRACK HARWIN FOR 1.6MM PCB	R167		036-13470-00	RES M/F 0805 470E 5%
P260		356-00010-26	PIN TRACK HARWIN FOR 1.6MM PCB	R168		036-14270-10	RES M/F 0805 2K7 1%
P270		356-00010-26	PIN TRACK HARWIN FOR 1.6MM PCB	R169		036-15100-10	RES M/F 0805 10K 1%
PL101		070-01001-00	D-RANGE 15 WAY COMPL T800	R170		036-14220-00	RES M/F 0805 2K2 5%
PL110		240-00021-03	LIM) HEADER 2X7 WAY SMD	R171		036-13150-10	RES M/F 0805 150E 1%
Q100		000-10008-17	S) XSTR SMD BC817-25 NPN SOT23	R172		036-16180-00	RES M/F 0805 180K 5%
Q101		000-10017-00	LS) XSTR SMD BF170LT1 SOT23	R173		036-15100-10	RES M/F 0805 10K 1%
Q102		000-10008-17	S) XSTR SMD BC817-25 NPN SOT23	R175		036-15220-00	RES M/F 0805 22K 5%
Q103		000-10017-00	LS) XSTR SMD BF170LT1 SOT23	R176		036-15100-10	RES M/F 0805 10K 1%
Q110		000-10008-57	S) XSTR SMD BCW70 PNP SOT23 SS	R177		036-15100-10	RES M/F 0805 10K 1%
Q111		000-10008-17	S) XSTR SMD BC817-25 NPN SOT23	R178		036-14100-10	RES M/F 0805 1K 1%
Q112		000-10008-17	S) XSTR SMD BC817-25 NPN SOT23	R179		036-14100-10	RES M/F 0805 1K 1%
Q113		000-10008-57	S) XSTR SMD BCW70 PNP SOT23 SS	R180		036-14100-10	RES M/F 0805 1K 1%
Q114		000-10008-69	S) XSTR SMD BC869 PNP 1W SOT89	R181		036-15100-10	RES M/F 0805 10K 1%
Q120		000-10008-48	S) XSTR SMD BCW60 NPN SOT23 SS	R182		036-16220-00	RES M/F 0805 20K 5%
Q121		000-10008-57	S) XSTR SMD BCW70 PNP SOT23 SS	R183		036-15100-10	RES M/F 0805 10K 1%
Q122		000-10008-17	S) XSTR SMD BC817-25 NPN SOT23	R184		036-14470-10	RES M/F 0805 4K7 1%
Q123		000-10008-57	S) XSTR SMD BCW70 PNP SOT23 SS	R185		036-16100-10	RES M/F 0805 100K 1%
Q124		000-10008-17	S) XSTR SMD BC817-25 NPN SOT23	R186		036-15100-10	RES M/F 0805 10K 1%
Q125		000-10008-57	S) XSTR SMD BCW70 PNP SOT23 SS	R187		036-16150-00	RES M/F 0805 150K 5%
Q126		000-10008-57	S) XSTR SMD BCW70 PNP SOT23 SS	R188		036-16100-10	RES M/F 0805 100K 1%
Q127		000-10008-48	S) XSTR SMD BCW60 NPN SOT23 SS	R189		036-14100-10	RES M/F 0805 1K 1%
Q128		000-00030-95	S) XSTR 2N6107 PNP TO220 AF	R190		036-13220-10	RES 0805 220E 1%
Q129		000-10008-57	S) XSTR SMD BCW70 PNP SOT23 SS	R191		036-12100-10	RES M/F 0805 10E 1%
Q135		000-10008-48	S) XSTR SMD BCW60 NPN SOT23 SS	R192		036-13680-00	RES M/F 0805 680E 5%
Q200		000-10008-48	S) XSTR SMD BCW60 NPN SOT23 SS	R193		036-16100-10	RES M/F 0805 100K 1%
Q216		000-00031-02	S)XSTR 2SC3102 UHF 60W 6LFL	R194		036-14150-10	RES M/F 0805 1K5 1%
Q217		000-00031-02	S)XSTR 2SC3102 UHF 60W 6LFL	R195		036-12220-00	RES M/F 0805 22E 5%
R100		036-14820-10	RES M/F 0805 8K2 1%	R197		036-12220-00	RES M/F 0805 22E 5%
R101		036-13470-00	RES M/F 0805 470E 5%	R198		036-12220-00	RES M/F 0805 22E 5%
R102		036-14100-10	RES M/F 0805 1K 1%	R200		045-05100-02	RES NTC 10K 2% Metal tagged
R103		036-15100-10	RES M/F 0805 10K 1%	R201		036-13100-10	RES M/F 0805 100E 1%
R104		036-15100-10	RES M/F 0805 10K 1%	R202		036-13560-10	RES M/F 0805 560E 1%
R105		036-14100-10	RES M/F 0805 1K 1%	R203		036-14470-10	RES M/F 0805 4K7 1%
R106		036-14680-10	RES M/F 0805 6K8 1%	R204		036-14470-10	RES M/F 0805 4K7 1%
R107		036-14470-10	RES M/F 0805 4K7 1%	R205		036-13390-10	RES M/F 0805 390E 1%
R109		036-14100-10	RES M/F 0805 1K 1%	R206		036-13390-10	RES M/F 0805 390E 1%
R111		036-14100-10	RES M/F 0805 1K 1%	R207		036-14680-10	RES M/F 0805 6K8 1%
R112		036-15100-10	RES M/F 0805 10K 1%	R208		036-15100-10	RES M/F 0805 10K 1%
R113		036-14100-10	RES M/F 0805 1K 1%	R209		036-14470-10	RES M/F 0805 4K7 1%
R114		036-14470-10	RES M/F 0805 4K7 1%	R210		045-04470-00	RES NTC SMD 4K7 5% 20MW
R115		036-17100-10	RES M/F 0805 1M 1%	R223		036-11330-00	RES M/F 0805 3E3 5%
R116		036-14100-10	RES M/F 0805 1K 1%	R224		036-11330-00	RES M/F 0805 3E3 5%
R117		036-14220-00	RES M/F 0805 2K2 5%	R225		036-11330-00	RES M/F 0805 3E3 5%
R118		036-16100-10	RES M/F 0805 100K 1%	R226		036-03118-10	RES 18R 1W SMD 2512
R119		036-15100-10	RES M/F 0805 10K 1%	R227		036-03270-10	RES 270 OHM 1 WATT 2512 CHIP
R120		036-13680-00	RES M/F 0805 680E 5%	R230		036-03270-10	RES 270 OHM 1 WATT 2512 CHIP
R121		036-17100-10	RES M/F 0805 1M 1%	R231		039-50500-00	RES TERM 50E 50W RFP50-50TCG
R122		036-14220-00	RES M/F 0805 2K2 5%	R235		036-13100-10	RES M/F 0805 100E 1%
R123		036-14100-10	RES M/F 0805 1K 1%	R236		036-13100-10	RES M/F 0805 100E 1%
R124		036-13680-00	RES M/F 0805 680E 5%	R237		036-03100-02	RES 100E 1206 200V 250MW RC01
R125		036-16100-10	RES M/F 0805 100K 1%	R238		036-03100-02	RES 100E 1206 200V 250MW RC01
R126		036-16220-00	RES M/F 0805 220K 5%	R240		039-50500-00	RES TERM 50E 50W RFP50-50TCG
R127		045-04470-00	RES NTC SMD 4K7 5% 20MW	R245		036-03130-10	RES 30E 1W SMD 2512
R128		036-16220-00	RES M/F 0805 220K 5%	R246		036-03130-10	RES 30E 1W SMD 2512
R129		036-15100-10	RES M/F 0805 10K 1%	R247		036-11330-00	RES M/F 0805 3E3 5%
R130		036-16220-00	RES M/F 0805 220K 5%	RV101		042-04500-05	RES PRESET SMD 5K CER 4MM SQ
R131		036-15330-10	RES M/F 0805 33K 1%	RV103		042-05500-05	RES PRESET SMD 50K CER 4MM SQ
R132		036-14100-10	RES M/F 0805 1K 1%	RV105		042-04500-05	RES PRESET SMD 5K CER 4MM SQ
R133		036-15270-10	RES M/F 0805 27K 1%	RV107		042-05500-05	RES PRESET SMD 50K CER 4MM SQ
R134		036-14330-10	RES M/F 0805 3K3 1%	%RV109		044-04200-06	RES PRE MULT 2K 15T PNL MITG
R135		036-16470-00	RES M/F 0805 470K 5%	RV113		042-06500-05	RES PRESET SMD 500K CER 4MM SQ
R136		036-16470-00	RES M/F 0805 470K 5%	RV115		042-05200-05	RES PRESET SMD 20K CER 4MM SQ
				SK101		240-10000-05	CONN SMD SKT 8W 2R M-MATCH
				SK103		240-10000-05	CONN SMD SKT 8W 2R M-MATCH
				SK201		240-02100-44	SKT COAX MINI JACK PCB MT ANG.



## T859 Mechanical &amp; Miscellaneous Parts (220-01422-03)

IPN	Legend	Description	IPN	Legend	Description
012-04100-05	1	CAP F/THRU 1N SUPPR FLTR S-MTG	353-00010-24	32	WSHR M4x8MM FLAT
044-04200-07	2	RES POT COVER H-83P	356-00010-01	33	TAG SOLDER 3MM SHORT M6132/3.2
045-05100-02	3	RES NTC 10K 2% METAL TAGGED R200	356-00010-03	34	TAG SOLDER 3MM LONG M614/3.2
070-01001-00	4	D-RANGE 15 WAY COMPL T800	356-00010-05	35	TAG SOLDER 4MM LONG M6144/4.2
201-00030-02		WIRE T/C WIRE 7/0.2 PVC RED Power feed for fan.	357-00010-45	36	CLAMP CABLE 4.8MM P CLIP
201-00050-25		AUTO 154 RED 41/0.3 PVC DC+ from D-range PCB.	360-00010-41	37	BUSH SHORTY BLK
201-00050-26		AUTO 154 BLACK 41/0.3 PVC DC- from D-range PCB.	362-00010-07	38	GASKET SIL INSULATING TO-220
219-02591-01	5	LOOM RIBBON 8 WAY FOR T839PA	362-00010-13	39	BUSH INSULATING 1.1MM TOP HAT
219-02612-00		RG316 CABLE ASSY T869PA BNC to SK201 cable assembly with connectors.	362-00010-33	40	GROMMET LED MTG 3MM
219-02639-00		CABLE ASSEMBLY RG223/U N TO BNC Exciter/PA connecting cable assembly.	399-00010-51		BAG PLASTIC 75X100MM
219-02709-00	6	T858/T859 N-TYPE CONNECTOR SUB	400-00020-30		HEATSHRINK 3MM
220-01422-03	7	PCB T859PA SERIES II	410-00010-43		PKG T296 AMPAC REF 73-46
220-01442-03	41	PCB T858/T859 SII DRNL COUPLER			
240-02100-17	8	SKT COAX BNC PNL JAC CRP RG316			
240-04020-62		SKT 2 W RECEP SHORTING LINK PL110			
240-06010-15	9	BLOCK LATCHING 15W D RANGE			
258-00010-08	10	FAN 12V 119 x 119 x 25 (PAPST)			
302-05204-00	11	BRKT A3M2314 F/THRU MTG T859			
303-23146-00	12	COVER SIDE T869PA			
308-01007-01	13	HANDLE BASE STATION SERIES II			
308-13131-02	14	HEATSINK T859 PA DRILLED DCST			
316-06651-00	15	PNL PA NO INP DRV SER II DBL			
319-01190-01	16	SHIELD WALL HARM. FILTER 869PA			
319-01201-00	17	SHIELD LID HARM. FILTER 869PA			
319-01202-00	18	SHIELD T869PA CONTROL CIRCUIT			
319-30061-00	19	SPACER PLATE T889 WIRELINE			
319-30064-00	20	SPACER HSINK RF MODULE 869PA			
319-30068-00	21	SPACER, T859 PCB HYBRID			
345-00040-16	22	SCRW M3X20MM P/POZ ST BZ			
349-00010-59	23	SCRW 6-32 X 3/8 P/PH T/T ZP			
349-00020-07	24	SCRW 4-40 X 5/16 P/POZ T/T BLK			
349-00020-09	25	SCRW T/T 4-40X3/8 IN P/POZ BLK			
349-00020-36	26	SCREW TT M3X8m PANTORX BLK			
349-00020-43	27	SCRW T/T M4X12MM P/POZ BZ			
349-00020-49	28	SCRW T/T M4X35MM P/POZ BZ			
349-00020-55	29	SCRW M3X8 P/P T/T BLCKZNC CHRMM			
352-00010-29	30	NUT M4 NYLOC HEX			
353-00010-10	31	WSHR M3 FLAT 7MMX0.6MM ST BZ			



**replace A4 pages D5.3.23/D5.3.24 with A3 pages D5.3.23/D5.3.24**

**replace A4 pages D5.3.23/D5.3.24 with A3 pages D5.3.23/D5.3.24**

**T859 Grid Reference Index (IPN 220-01422-03)****How To Use This Grid Reference Index**

The first digit in the PCB layout reference is a "1" or "2", indicating the top or bottom side layout respectively, and the last two characters give the location of the component on that diagram.

The first digit in the circuit diagram reference is the sheet number, and the last two characters give the location of the component on that sheet.

<u>Device</u>	<u>PCB</u>	<u>Circuit</u>	<u>Device</u>	<u>PCB</u>	<u>Circuit</u>	<u>Device</u>	<u>PCB</u>	<u>Circuit</u>	<u>Device</u>	<u>PCB</u>	<u>Circuit</u>
C100	1:F6	1-B7	C164	1:T3	1-C1	#C273	1:H3	2-L1	L209	1:R5	2-D4
C101	1:E6	1-B6	C166	1:B1	1-G0	C274	1:P3	2-E3	L210	1:R4	2-D4
C102	1:B2	1-C7	C167	1:B1	1-I0	C275	1:F7	2-C9	L211	1:Q6	2-C5
C103	1:B1	1-C6	C168	1:C1	1-I0	C276	1:F7	2-C8	L212	1:R6	2-C4
C104	1:E6	1-D7	C169	1:J1	1-J5	#C277	1:C9	2-Q3	%L213	1:S9	2-B3
C105	1:E5	1-D6	C172	1:F2	1-J0	#C278	1:B8	2-Q3	L235	1:K7	2-K4
C107	1:B4	1-E8	C173	1:E2	1-K0	#C280	1:A7	2-R3	L237	1:M8	2-H4
C108	1:C3	1-F5	C174	1:D2	1-L0	C282	1:D7	2-Q2	L238	1:M9	2-H4
C109	1:E4	1-G6	C175	1:D2	1-M0	#C283	1:D7	2-Q2	L239	1:K6	2-K3
C110	1:E4	1-H6	C176	1:F4	1-M0	C284	1:E9	2-D6	L240	1:H5	2-M3
C111	1:F4	1-I6	C177	1:E3	1-N0	#C285	1:D8	2-P3	L241	1:N5	2-F3
C112	1:B2	1-I6	C178	1:F3	1-N0	C286	1:D7	2-P2	L242	1:K5	2-K3
C113	1:F5	1-J8	C197	1:E5	1-P0	C287	1:F9	2-E6	L243	1:K4	2-K3
C114	1:B3	1-J6	C198	1:C5	1-Q0	C293	1:G7	2-M3	L246	1:M2	2-H1
C115	1:F5	1-K8	C200	1:Q2	2-H7				L247	1:M2	2-H1
C116	1:A3	1-K8	C201	1:Q1	2-H7	D101	1:M5	1-B0	L253	1:F7	2-C9
C117	1:B3	1-L8	C202	1:F2	2-K7	D105	1:C4	1-F8	#L254	1:D9	2-P3
C119	1:C4	1-O7	C203	1:E2	2-K7	D105	1:C4	1-F8	#L255	1:C8	2-Q3
C120	1:D6	1-O7	C204	1:B2	2-L7	D110	1:F5	1-G8	#L256	1:A8	2-R3
C121	1:D5	1-O8	C205	1:E3	2-M7	D110	1:F5	1-G8	L257	1:E9	2-D7
C122	1:D5	1-O8	C206	1:F3	2-M7	D112	1:V9	1-I4	#L258	1:D7	2-P2
C123	1:B5	1-P9	C207	1:F3	2-N7	D114	1:V8	1-I4	L259	1:D7	2-Q2
C124	1:B5	1-P9	C208	1:B6	2-P7	D115	1:E5	1-F5	L260	1:C7	2-Q2
C125	1:C5	1-Q7	C209	1:C6	2-Q7	D115	1:E5	1-F5			
C126	1:B5	1-Q8	C210	1:D6	2-Q7	D120	1:C3	1-F5	LINK200	1:N5	2-M0
C127	1:B6	1-Q8	C211	1:C6	2-Q7	D120	1:C3	1-G4			
C128	1:C6	1-Q7	C214	1:D3	1-Q0	D190	1:V9	1-J4	P105	1:U5	1-B1
C129	1:B5	1-R8	C215	1:E3	1-R0	D205	1:G7	2-C8	P110	1:U3	1-B0
C130	1:B5	1-R8	C218	1:Q5	2-C5	D206	1:E9	2-D7	P130	1:A6	1-U8
C131	1:A5	1-S8	C219	1:R4	2-B5				P200	1:F7	2-N3
C132	1:B5	1-S9	C220	1:R5	2-C4	IC100	1:E5	1-D7	P201	1:E9	2-P3
C133	1:A5	1-T8	C221	1:R4	2-C3	IC100	1:E5	1-I8	P210	1:M7	2-G4
%C134	1:A6	1-T8	C222	1:R4	2-E3	IC100	1:E5	1-D7	P212	1:M3	2-G1
C136	1:B2	1-M4	C223	1:Q4	2-E4	IC100	1:E5	1-O0	P214	1:M7	2-J4
C137	1:D3	1-M3	C224	1:Q4	2-E5	IC100	1:E5	1-H6	P216	1:M3	2-J1
C138	1:D3	1-M3	C225	1:Q6	2-C4	IC105	1:D5	1-O7	P218	1:K7	2-J5
C139	1:B4	1-N6	C226	1:R6	2-C3	IC105	1:D5	1-S0	P220	1:K3	2-J2
C140	1:F1	1-N2	C227	1:S8	2-A3	IC105	1:D5	1-P0	P222	1:K7	2-K5
C141	1:C3	1-O4	C228	1:R8	2-B3	IC105	1:D5	1-I2	P224	1:K3	2-K2
C142	1:D3	1-O4	#C247	1:H7	2-L4	IC105	1:D5	1-P8	P226	1:K7	2-L5
C143	1:E1	1-O2	C249	1:N7	2-G4	IC110	1:E3	1-T0	P228	1:K3	2-L2
C144	1:F1	1-O2	C250	1:H7	2-L4	IC110	1:E3	1-N0	P250	1:E7	2-N0
C145	1:D1	1-O3	#C252	1:K7	2-K4	IC110	1:E3	1-M3	P260	1:G9	2-P0
C146	1:D2	1-O4	#C253	1:K7	2-K4	IC130	1:B1	1-H0	P270	1:D7	2-Q2
C147	1:B4	1-P6	C254	1:J7	2-L4	IC140	1:E2	1-K0			
C148	1:E2	1-P3	#C256	1:M7	2-H4	IC200	1:E3	1-U0	PL101	2:S4	1-B0
C149	1:E1	1-P2	#C257	1:M7	2-J4	IC200	1:E3	1-Q0	PL110	1:C2	
C150	1:D2	1-P4	C258	1:K6	2-L3	IC200	1:E3	2-M8			
C151	1:B4	1-P5	C259	1:L5	2-K3	#IC210	1:S5	2-C3	Q100	1:F4	1-I6
C152	1:E2	1-Q2	C260	1:L6	2-J3				Q101	1:B3	1-J6
C153	1:F2	1-Q4	C261	1:K4	2-L3	%L100	1:A5	1-T8	Q102	1:F5	1-J8
C154	1:F2	1-Q2	C262	1:H3	2-L2	L120	1:F2	1-Q2	Q103	1:A3	1-K8
C156	1:D4	1-G1	C263	1:J3	2-L1	L161	1:U4	1-B1	Q110	1:B5	1-Q9
C157	1:D4	1-H1	#C264	1:K3	2-K1	L162	1:T3	1-C1	Q111	1:B6	1-Q8
C158	1:D4	1-I1	#C265	1:K3	2-K1	L200	1:Q1	2-H8	Q112	1:C6	1-Q7
C159	1:D3	1-K1	C268	1:N3	2-G1	L201	1:F2	2-K8	Q113	1:B5	1-R8
C161	1:T3	1-B1	#C269	1:M3	2-H1	L202	1:B6	2-P7	Q114	1:A5	1-S8
C162	1:U4	1-B1	#C270	1:M3	2-J1	L203	1:D6	2-Q7	Q120	1:B4	1-N6
C163	1:U3	1-C1	C272	1:L6	2-J3	L208	1:Q5	2-D5	Q121	1:C4	1-N4

<u>Device</u>	<u>PCB</u>	<u>Circuit</u>	<u>Device</u>	<u>PCB</u>	<u>Circuit</u>	<u>Device</u>	<u>PCB</u>	<u>Circuit</u>	<u>Device</u>	<u>PCB</u>	<u>Circuit</u>
Q122	1:F1	1-O2	R163	1:E2	1-P3						
Q123	1:B4	1-O6	R164	1:E1	1-P2						
Q124	1:F1	1-O3	R165	1:E1	1-P2						
Q125	1:D3	1-O4	R166	1:B4	1-P6						
Q126	1:D2	1-P4	R167	1:B4	1-P5						
Q127	1:B4	1-P5	R168	1:E1	1-P2						
Q128	1:D2	1-P3	R169	1:D2	1-P4						
Q129	1:B3	1-Q6	R170	1:E2	1-P2						
Q135	1:C4	1-K2	R171	1:F1	1-P2						
Q200	1:F3	2-P7	R172	1:B4	1-P6						
Q216	1:L7	2-J4	R173	1:D2	1-Q4						
Q217	1:L3	2-J1	%R174	1:F2	1-Q6						
			R175	1:B3	1-Q6						
R100	1:F5	1-C7	R176	1:B3	1-Q6						
R101	1:E5	1-C6	R177	1:D4	1-H2						
R102	1:D1	1-C7	R178	1:D4	1-H2						
R103	1:F6	1-D7	R179	1:D4	1-H1						
R104	1:E5	1-D6	R180	1:D4	1-I1						
R105	1:B4	1-E8	R181	1:D4	1-I2						
R106	1:E4	1-F7	R182	1:D5	1-J2						
R107	1:E4	1-F6	R183	1:C5	1-J2						
%R108	1:E6	1-F6	R184	1:C4	1-J1						
R109	1:F5	1-F8	R185	1:C3	1-K2						
%R110	1:F5	1-F8	R186	1:C3	1-K2						
R111	1:C3	1-F5	R187	1:C3	1-K2						
R112	1:E4	1-G6	R188	1:D3	1-L1						
R113	1:B3	1-G5	R189	1:B1	1-H0						
R114	1:E4	1-G6	R190	1:B1	1-H0						
R115	1:E4	1-H6	R191	1:C1	1-I0						
R116	1:E4	1-H5	R192	1:V9	1-J5						
R117	1:E4	1-H6	R193	1:D2	1-L0						
R118	1:F4	1-H8	R194	1:E2	1-L0						
R119	1:E5	1-H8	R195	1:E3	1-N0						
R120	1:V7	1-I5	R197	1:E5	1-O0						
R121	1:F5	1-I8	R198	1:C5	1-P0						
R122	1:F4	1-I8	R200	1:T2	2-H7						
R123	1:F5	1-I8	R201	1:D3	2-L8						
R124	1:V8	1-I5	R202	1:D3	2-L6						
R125	1:C5	1-N7	R203	1:D3	2-L8						
R126	1:E6	1-N7	R204	1:D3	2-L8						
R127	1:C5	1-N7	R205	1:F3	2-L7						
R128	1:D6	1-N7	R206	1:F3	2-L7						
R129	1:B5	1-O9	R207	1:F3	2-M7						
R130	1:D5	1-O8	R208	1:F3	2-N7						
R131	1:D5	1-O8	R209	1:F3	2-N7						
R132	1:D5	1-O8	R210	1:B6	2-P7						
R133	1:C4	1-O7	R223	1:R5	2-C4						
R134	1:B5	1-O9	R224	1:Q4	2-E4						
R135	1:C5	1-P7	R225	1:Q6	2-C4						
R136	1:D5	1-P8	R226	1:R7	2-B3						
R137	1:C5	1-P7	R227	1:R8	2-B2						
R138	1:D5	1-P8	R230	1:R7	2-B2						
R139	1:C6	1-P7	R231	1:N9	2-F3						
R140	1:B5	1-Q8	R235	1:E7	2-E8						
R141	1:B6	1-Q8	R236	1:G9	2-C7						
R142	1:B5	1-Q8	R237	1:D6	2-R2						
R143	1:B5	1-R9	R238	1:D6	2-R2						
R144	1:A5	1-R9	R240	1:G1	2-M3						
%R145	1:A5	1-T8	R245	1:K6	2-L3						
R146	1:V7	1-K4	R246	1:K4	2-L3						
R147	1:V7	1-K4	R247	1:L6	2-K3						
R148	1:V7	1-K4									
R149	1:E4	1-M4	RV101	1:C4	1-H8						
R150	1:D3	1-M2	RV103	1:C4	1-F8						
R151	1:E4	1-M4	RV105	1:C3	1-G6						
R152	1:D3	1-N4	RV107	1:C2	1-F5						
R153	1:E4	1-N3	%RV109	1:V6	1-K5						
R154	1:E4	1-N2	%RV111	1:V7	1-K4						
R155	1:B4	1-O6	RV113	1:C3	1-K2						
R156	1:C4	1-O4	RV115	1:C2	1-M0						
R157	1:D3	1-O4									
R158	1:D4	1-O4	SK101	1:T4	1-C0						
R159	1:B4	1-O6	SK103	1:A4	1-C0						
R160	1:E1	1-O2	SK201	1:R9	2-A3						
R161	1:C4	1-O6									
R162	1:D2	1-O4									