

TM8100 Mobiles User's Guide



About this Guide

This user's guide provides information about both TM8105 and TM8115 mobile radios and is divided into two parts.

- Part A explains how the TM8115 radio operates. The TM8105 radio has a control head without user controls, so no TM8105 operating information is needed.
- Part B outlines the installation procedure for both TM8105 and TM8115 radios, and gives the interface specifications for the TM8105 remote connector.

Important Safety Information

This user's guide also contains important safety information about using and installing TM8105 and TM8115 radios. Refer to page 6 for user safety instructions and page 18 for installation safety instructions.

Updating this Guide

In the interests of improving the performance, reliability or servicing of the equipment, Tait Electronics Ltd reserves the right to update both the equipment or this user's guide, without prior notice.

Part 1: Radio Operation

About this Guide	1
Important Safety Information	1
Updating this Guide	1
Safety Warnings	6
Warning: Safe Operation	6
Warning: High Temperatures	6
Warning: FCC RF Exposure Limits	6
Caution: Radio Protection	7
Getting Started	8
Radio Controls	8
Radio Indicators	10
LED Indicators	10
Audible Indicators	10
Basic Operation	11
Turning the Radio On and Off	11
Adjusting the Volume	11
Selecting a Channel	11
Making a Call	11
Transmit Timer	12
Receiving a Call	12
What You Hear on a Channel	12
Signalling Mute	12
Squelch	13
Monitor	13
Activating Monitor	13
Activating Squelch Override	13
Scanning	14
Activating Scanning	14
Nuisance Delete	14
Priority Scanning	14
Troubleshooting	15
Removing the Radio from the Vehicle	15
Notes	16

Safety Warnings



Warning: Safe Operation

- Switch the radio off at petrol filling stations or near flammable liquids or gases.
- Switch the radio off in the vicinity of explosive devices and blasting zones.
- Using a handheld microphone or a radio while driving a vehicle may violate the laws and legislation that apply in your country or state. Please check the vehicle regulations in your area.



Warning: High Temperatures

The bottom surface of the radio and the heatsink fins can become hot during prolonged operation. Do not touch these parts of the radio.



ATTENTION!

Warning: FCC RF Exposure Limits

This product generates RF (radio frequency) energy during transmissions. This device must be restricted to work-related use in an occupational/controlled exposure environment.

The radio operator must have control of the exposure conditions and duration of all persons exposed to the antenna of this transmitter to satisfy FCC RF exposure compliance. This device is not approved for general population use.

- This device must only be used with authorized accessories and antennas.
- The operator must ensure that the minimum safe distance of 0.9m (35 inches) between persons and the antenna is maintained during transmissions.

- This minimum safe distance is based on the assumption that there is a duty cycle of 50% transmit mode to stand-by or receive modes. The radio is in transmit mode when the PTT (press-to-talk) key on the microphone is pressed and the control head red LED (light emitting diode) glows.

Please refer to the following website for more information on what RF energy is and how to control your exposure to assure compliance with established RF exposure limits.

Website: <http://www.fcc.gov/oet/rfsafety/rf-faqs.html>



Caution: Radio Protection

Always remove the fuses from the radio power cable before charging the vehicle battery, connecting a second battery or using power from another vehicle (e.g. when “jump-starting” the vehicle).

Getting Started

This section provides a brief description of your radio's basic operation. If you need further information, contact your radio provider.

Radio Controls

The radio controls are the PTT key, volume control, on/off key, channel selection keys and function keys. Some keys may have functions assigned to both short and long key presses. A short key press is defined as less than one second and a long key press is more than one second.

The radio controls and their functions are summarized in the diagram and table on the following page.

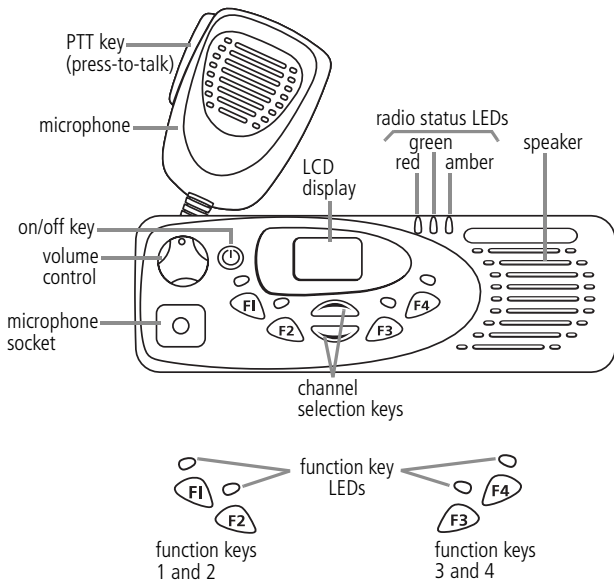

Symbol	Name	Function
	PTT	press and hold to transmit and release to listen
	volume control	rotate to change the speaker volume
⏻	on/off	a long press turns the radio on or off
⬆	channel selection keys	move up and down through the channel list
⬆	channel selection keys	move up and down through the channel list
F1	function keys	function keys
F2	1, 2, 3 and 4	
F3		
F4		

Radio Indicators

The LED indicators and the radio's audible tones all combine to give you information about the state of your radio. The way these indicators behave is affected by the way your radio is programmed.

The following sections describe the most common operation of the radio indicators.

LED Indicators

LED	Meaning
red (transmit)	glowing: your radio is transmitting
	flashing: your transmit timer is about to expire
green (receive and monitor)	glowing: there is activity on the current channel, even though you may not be able to hear it
	flashing: you have received a call with valid special signalling, or you have activated monitor or squelch override
amber (scanning)	glowing: your radio is scanning a group of channels for activity
	flashing: your radio has detected activity on a channel, and has halted on this channel
function key LEDs	the operation of these leds depends on the type of function programmed for each function key.

Audible Indicators

Your radio may be programmed so that whenever you press a key, the radio beeps to indicate whether or not your action is permitted.

A short, medium-pitched beep indicates that an action or selection is permitted. A long, low-pitched beep indicates that the action or selection is not permitted.

Basic Operation

This section describes the basic operation of your radio, including turning the radio on and off, adjusting volume, selecting channels, making calls and receiving calls.



Turning the Radio On and Off

A long press of the on/off key  turns the radio either on or off. When the radio is first turned on, the red, green and amber LEDs flash briefly and the radio gives two short beeps.



Adjusting the Volume

Rotate the volume control clockwise to increase the speaker volume and counterclockwise to decrease the volume. The volume control also changes the volume level of the radio's audible indicators.

Selecting a Channel

Use the channel selection keys  or  to scroll through the channel list until the channel you want is displayed.

Making a Call

1. Select the required channel or group using the channel selection keys  or .
2. Check the green LED.
If the green LED is glowing, the channel is busy and you cannot transmit.
3. Once the channel is clear (the green LED is off), lift the microphone off the microphone clip.
4. Hold the microphone about 5 cm (2 inches) from your mouth and press the PTT key to transmit.
5. Speak clearly into the microphone and release the PTT key when you have finished talking.



Note: You cannot change channels while transmitting.

Transmit Timer

Your radio may have a transmit timer that limits the amount of time you can transmit continuously. When the transmit timer is about to expire, the red LED flashes and the radio gives three beeps. You must release the PTT before you can transmit again.



Note: Your radio may be unable to transmit for a short time after the transmit timer has expired.

Receiving a Call

When there is valid activity on your radio's currently selected channel or group, the radio then unmutes and you can hear the call.

If the incoming call contains special signalling that matches the signalling programmed for your radio, the green LED flashes and your radio may give a ringing tone.

What You Hear on a Channel

Your radio may be programmed so that you hear all conversations on a channel, or your user group may be segregated from other user groups by using special signalling. The special signalling is used to control the muting and unmuting of your radio, so that your radio is muted when other user groups are talking and unmuted for members of your user group.

There are two muting controls that operate in your radio:

- signalling mute, and
- squelch.

Signalling Mute

The radio's signalling mute only allows the radio to unmute if the incoming call carries the tones specific to your user group. Your user group may use tones that are either audible, subaudible or both.

Squelch

The radio's squelch allows the radio to unmute only when the strength of the incoming signal is above a predetermined threshold. This means that only signals of reasonable intelligibility are made audible.

Monitor

The monitor function is used to check that the channel is clear before you make a call. While monitor is on, the green LED flashes continually.

Activating Monitor

1. Press the monitor function key and monitor overrides the signalling mute, allowing you to hear any traffic on the channel.



Note: Your radio may be programmed to activate monitor whenever the microphone is off the microphone clip.

2. Press the monitor function key again to turn monitor off, and the green LED no longer flashes.

Activating Squelch Override

1. Press and hold the monitor function key for longer than one second to override both squelch and the signalling mute.

This allows you to hear even faint and noisy signals.

2. Press the monitor function key again to return the radio to a quiet state.



Note: Squelch cannot be overridden when the radio is scanning.

Scanning

The scan function is used to monitor a programmed group of channels, looking for activity. When activity is detected on one of the scan group channels, the radio stops on that channel. The amber LED flashes and, if the channel signalling is valid, the radio unmutes and you can hear the call.

Scanning resumes when the channel is no longer busy or the signalling is no longer valid.

Activating Scanning

1. Place the microphone on the microphone clip.



Note: Your radio may be programmed to scan whenever the microphone is off the microphone clip.

2. Press the function key assigned to scanning. The amber LED glows to show that the radio is scanning.
3. Press the scanning function key again to cancel scanning, and the amber LED no longer glows.

Nuisance Delete

If a member channel of the scan group is busy for a long time and you do not wish to hear the conversation, you can temporarily delete it from the scan group by using the function key assigned to nuisance delete.

Alternatively, press and hold the scanning function key. When the scan group is next selected, the deleted channel is again part of the scan group.

Priority Scanning

One or two priority scan channels may be set. These channels are scanned more often than other channels and are scanned periodically when a non-priority channel is busy. Note that priority channels cannot be removed from the scan group using the nuisance delete function.

Troubleshooting

If the red, green and amber LEDs on the control head do not light up when the radio is turned on, it is likely that no power is reaching the radio. Check the following:

- Is the power connector firmly plugged into the rear of the radio?
- Are the in-line fuses in good condition?
- Is the power cable securely connected to the vehicle battery or power supply?

If all appears to be in order, then contact your radio provider for further assistance.

Removing the Radio from the Vehicle

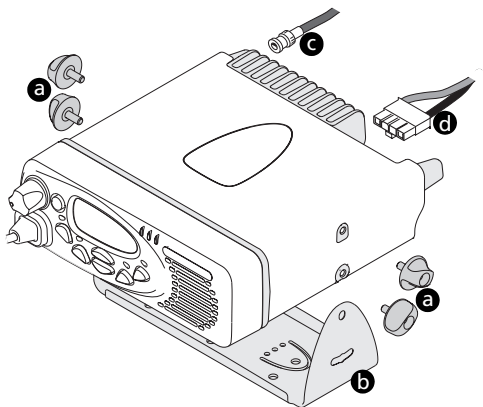

1. Switch off the radio.
2. Unscrew the four thumb screws **a** that secure the radio to the U-bracket **b**.
3. Lift the radio clear of the U-bracket.
4. Disconnect the antenna **c** and power cable **d** from the rear of the radio.

Notes

Part 2: Radio Installation Procedures

Installation Warnings	18
Warning: Safe Radio Mounting	18
Warning: Interference With Vehicular Electronics	18
Warning: Liquefied Petroleum Gas Powered Vehicles	18
Caution: Non-Standard Radio Installations	19
Caution: Negative Ground Supply	19
Installation Planning	20
MPT 1362 Code of Practice	20
Checking Equipment	20
Installation Tools	20
Microphone Clip Installation Tools	21
Mounting Position	21
Radio Installation	22
Mounting the U-bracket	22
Installing the Control Head on the Radio Body	22
Removing the Control Head	23
Installing the Microphone	23
Installing the Antenna	24
Warning: RF Exposure Hazard	24
Antenna Termination	24
Power Cable	25
Installing the Power Cable	25
Installing the Radio in the U-bracket	26
Microphone Clip (TM8115 Radios Only)	27
TM8105 Remote Connector	27
Installation Checks	28
Other Installation Options	28

Installation Warnings



Warning: Safe Radio Mounting

- Mount the radio securely so that it will not break loose in the event of a collision. An unsecured radio is dangerous to the vehicle occupants.
- Mount the radio where it will not interfere with the deployment of passenger air bags.
- Do not mount the radio vertically, with the control head facing down. This will violate compliance with the European Union standard EN 60950, Safety of Information Technology Equipment.



Warning: Interference With Vehicular Electronics

Some vehicular electronic devices may be prone to malfunction, due to the lack of protection from RF energy present when your radio is transmitting.

Examples of vehicular electronic devices that may be affected by RF energy are:

- electronic fuel injection systems
- electronic anti-skid braking systems
- electronic cruise control systems.

If the vehicle contains such equipment, consult the vehicle manufacturer or dealer in order to determine whether these electronic circuits will perform normally when the radio is transmitting.



Warning: Liquefied Petroleum Gas Powered Vehicles

Radio installation in vehicles powered by LP (liquefied petroleum) gas with the LP gas container in a sealed-off space within the interior of the vehicle must conform to the National Fire Protection Association Standard

NFPA 58. This standard states that the radio equipment installation must meet the following requirements.

- The space containing the radio equipment shall be isolated by a seal from the space containing the LP gas container and its fitting.
- Outside filling connections shall be used for the LP gas container and its fittings.
- The LP gas container space shall be vented to the outside of the vehicle.



Caution: Non-Standard Radio Installations

The installation U-bracket described in this guide has been designed so that there is enough airflow around the radio to provide cooling.

If a non-standard installation method is used, care must be taken that sufficient heat can be dissipated from the radio heatsink fins and the bottom surface of the radio chassis.

For this to be achieved, there must be a gap of more than 10mm (0.4 inch) between the bottom surface of the radio chassis and the mounting surface. This is illustrated in the following diagram.

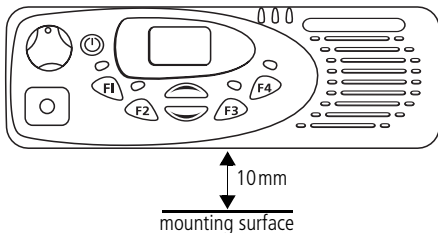

Caution: Negative Ground Supply

TM8100 radios are designed to operate only in a negative ground system.

Installation Planning

The procedures outlined in this and the following sections are for installing a TM8105 or TM8115 radio in a vehicle, using a standard U-bracket.

MPT 1362 Code of Practice

TM8100 radios should be installed in accordance with the MPT 1362 Code of Practice. This code of practice covers the installation of mobile radio equipment in land based vehicles and has been developed by the United Kingdom Radiocommunications Agency.

The full text of the MPT 1362 Code of Practice can be found at the Radiocommunications Agency website: <http://www.radio.gov.uk/>

Checking Equipment

Unpack the radio and check that you have the following items:

- radio control head with connecting loom
- radio body
- microphone with microphone clip and screws (TM8115 only)
- installation kit, consisting of:
 - U-bracket with screws
 - power cable with DC connector
 - 10A fuses
 - fuse holders
 - BNC antenna plug.

Installation Tools

- Portable drill
- 8mm (0.3 inch) socket
- BNC crimp tool
- In-line RF power meter capable of measuring forward and reflected power at the operating frequency of the radio

Microphone Clip Installation Tools

- Centre punch
- Drill bit
- Pozidriv screwdriver
- Hammer

Mounting Position

Inspect the vehicle and determine the safest and most convenient location for mounting the radio.

The installation must meet the following requirements:

- sufficient clearance behind the radio for the heatsink and cables
- a large enough flat surface so that the mounting bracket will not be distorted
- no danger of the radio interfering with air bag deployment.

Radio Installation

Mounting the U-bracket

Screw the U-bracket in the chosen mounting position using the self-tapping screws provided. At least four screws must be installed.



Note: If the U-bracket is being mounted over a curved surface, the U-bracket tabs can be bent slightly.



Caution: Check that the tightening of the screws does not distort the U-bracket.

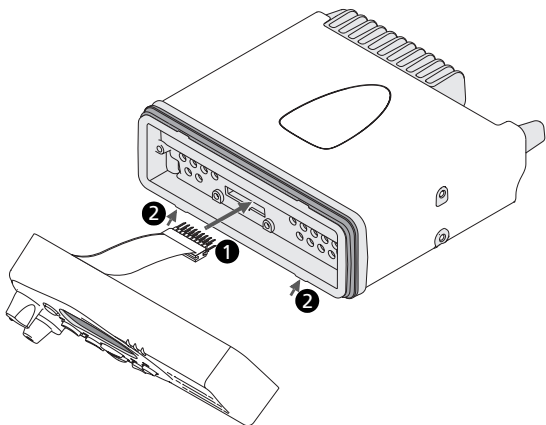

Installing the Control Head on the Radio Body

The orientation of the U-bracket mounting determines which way up the control head is mounted on the radio body. The numbers in the diagram above refer to the numbered steps below.

1. Plug the control head loom onto the control head connector.
2. Insert the bottom edge of the control head onto the two clips in the front of the radio chassis, then snap into place.

Removing the Control Head

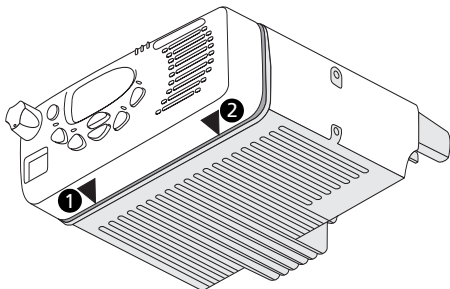

Caution: During this procedure, take care that the chassis seal is not damaged. Damage to this seal reduces environmental protection.

1. On the underside of the radio, insert a flat-bladed screwdriver between the control head and the radio chassis seal, in either position **1** or **2**.



Note: Insertion points **1** and **2** are indicated on the radio chassis by a dot-dash-dot pattern (•—•).

2. Use the screwdriver to lift the control head off the chassis clip, then repeat in the other position. The control head can now be removed from the radio body.

Installing the Microphone



Caution: The microphone grommet must be installed whenever the microphone is plugged into the microphone socket. When installed, the grommet has two functions:

- to prevent damage to the microphone socket when there is movement of the microphone cord, and
- to ensure that the control head is sealed against water, dust and other environmental hazards.

1. Plug the microphone into the microphone socket on the control head.
2. Slide the microphone grommet along the microphone cord and push two adjacent corners of the grommet into the microphone socket cavity.
3. Squeeze the grommet and push the remaining corners into position.
4. Check that the grommet is seated correctly in the cavity.

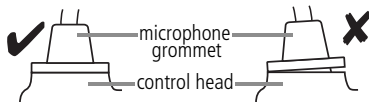

Installing the Antenna

Install the external antenna according to the supplier's instructions. Good quality 50 ohm coaxial cable must be used, such as RG58 or UR76.



Caution: The cable should be routed in a manner that minimizes coupling into the electronic control systems of the vehicle.



Warning: RF Exposure Hazard

To comply with FCC RF exposure limits, this product must be installed using an externally mounted antenna with either a 2.15 dBi or 5.15 dBi gain.

This antenna must not be mounted at a location such that any person or persons can come closer than 0.9m (35 inches) to the antenna.

Antenna Termination

1. Run the free end of the coaxial cable to the radio's mounting position and cut it to length, allowing 20 - 30cm (8 - 12 inches) excess.
2. Terminate the free end of the cable with the BNC plug supplied.

Power Cable



Caution: This radio is designed to operate from a nominal 12V negative ground supply and may draw up to 8A of current. The radio will tolerate a supply voltage range of 10.8V to 16.0V at the radio.

In vehicles with a supply voltage greater than 16.0V, such as many trucks, it is essential to provide a suitably rated DC to DC converter. This will isolate the radio from excessive battery voltage and provide the correct DC operating conditions.

Installing the Power Cable



Caution: Disconnecting the vehicle's battery may cause problems with some electronic equipment, such as vehicle alarms, engine management systems and in-car entertainment systems. Check that the vehicle owner has the necessary information to make all electronic equipment function correctly after battery reconnection.

1. Disconnect the vehicle's battery, unless specifically prohibited from doing so by the customer, vehicle manufacturer, agent or supplier.

If the battery is not disconnected, exercise extreme caution throughout the installation and install the fuses only when the installation is ready to be checked (see "Installation Checks" on page 28).

2. Determine where the power cable will be routed.



Caution: The power cable should be protected from engine heat, sharp edges and from being pinched or crushed.

3. Cut the negative and the positive wires where the in-line fuse holders will be placed (as close to the battery as possible).



Note: Do not install the fuses until the installation is ready to be checked.

4. Insert each end of the negative wire into one of the in-line fuse holders and crimp them to force the metal contacts onto the wires.
5. Connect the negative wire to the battery ground.
6. Repeat step 4 for the positive wire and connect it to the positive terminal of the battery.

Installing the Radio in the U-bracket

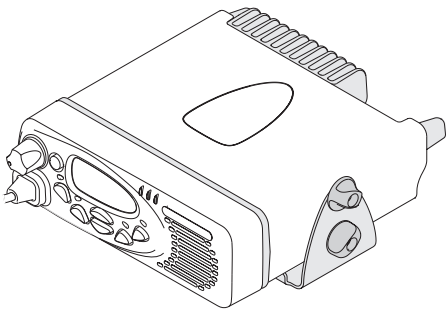

1. Connect the antenna and power cables to the rear of the radio.
2. Position the radio in the U-bracket so that the holes in the U-bracket line up with the holes in the radio chassis.
3. Screw the radio into position using the four thumb screws but without fully tightening the screws.
4. Position the radio in the U-bracket for best viewing angle, then tighten the thumb screws.

Microphone Clip (TM8115 Radios Only)

Install the microphone clip in the most convenient location for the radio user. It must be within easy reach of the user, but in such a position that the microphone PTT key cannot be inadvertently activated or jammed on.

TM8105 Remote Connector

The TM8105 has a 9-way D-range socket on the control head, for remote connection. The pin allocations of the remote connector are shown in the following diagram and table.

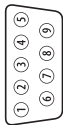
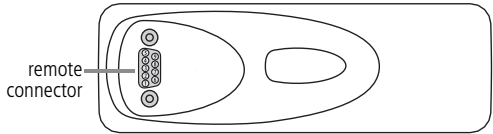

Pin	Signal	Description
1	RX_AUD	receive audio output (after volume control)
2	TXD	asynchronous serial port: transmit data
3	MIC_AUD	microphone audio input
4	RXD	asynchronous serial port: receive data
5	ON_OFF	hardware power on/software power off
6	+13V8_BATT	unswitched 13.8V power supply
7	PTT	PTT input from microphone, with hookswitch signal
8	AGND	analogue ground
9	DGND	digital ground

Installation Checks

1. Insert the fuses into the power leads.
2. TM8115 radios only.
Switch on the radio to confirm that it is operational (see "Turning the Radio On and Off" on page 11).



Caution: Do not transmit yet.

3. Connect an in-line power meter between the radio and the antenna and measure the forward and reflected power levels.
Less than 4% of the forward power should be reflected. If this is not achieved, check the installation, including the antenna length.
4. TM8115 radios only.
Once the reflected power levels are within tolerance, make a call to another party on the radio (see "Selecting a Channel" and "Making a Call", on page 11).

Other Installation Options

A wide range of other radio installation options are available, such as desktop installation, DIN mounting and locking bracket installation.

Contact your radio provider for further information.

