

Handling Mutator®

Always pick up and hold your Mutator vehicle from the back as shown, or from the front and back with both hands. Keep hair, hands, fingers, face and loose clothing away from wheels while the vehicle is switched on or while the transmitter is operating. Never pick up by the wheels. (Fig. 1)

Battery Charging and Care (Battery Pack and Charger included only with Mutator model no. 2351; not included with model no. 2350. Retailer decides which version to carry.) Vehicle will not run without a 9.6V rechargeable NiCd or NiMH battery pack and matching charger, commonly available for R/C vehicles at many toy and hobby dealers. Always follow the instructions that came with your battery pack and charger. Adult supervision of battery charging is required.

Drain Down – Cool Down – Charge Up

1. For best performance, run battery pack ALL THE WAY DOWN before recharging. Run until wheels slow to a stop.
2. Allow the battery pack to cool AT LEAST 20 MINUTES before recharging.
3. Charge fully according to the battery/charger manufacturer's instructions. Charging times differ with different types, brands, models, ages and conditions of battery packs and chargers. The first few charges of a new battery will provide shorter run times than later charges. You may need to repeat steps 1, 2 and 3 six or seven times to break in battery.

Battery Heat

1. Battery gets hot after use! This is normal, but be careful. Wait until battery is cool (20 minutes or more if needed) before charging. Charging batteries when they are hot will severely reduce the number of times they can be recharged.
2. After charging, battery pack will be warm. This is normal.

Running and Charging Times

1. NiCd and NiMH battery packs are not like alkaline batteries. They lose all their power suddenly, not gradually, and vehicle will stop very soon after slowing down becomes noticeable, with little warning. This is normal.
2. Typical running time will be between 9 to 15 minutes for a typical freshly charged NiCd battery pack in good condition, depending on how you operate your vehicle, but observe how long *your* battery runs in *your* vehicle under the conditions *you* operate in. Running time may vary over life of battery, with the first 6 charge cycles yielding significantly shorter run times than later charges. "Cycle" your battery (Drain Down/Cool Down/Charge Up) at least 6 times before evaluating run time.

IMPORTANT: NEW RECHARGEABLE BATTERIES NEED SEVERAL CHARGE/DISCHARGE CYCLES TO DELIVER MAXIMUM POWER AND LONGEST RUNNING TIMES. A FRESHLY CHARGED BATTERY (STILL WARM) WILL DELIVER THE LONGEST RUNNING TIME.

Battery Installation

- The bed lid of the vehicle removes to reveal the battery compartment.
1. Push BATTERY LATCH on the back of the vehicle downward to open and remove BATTERY LID. (Fig. 2 & 3)

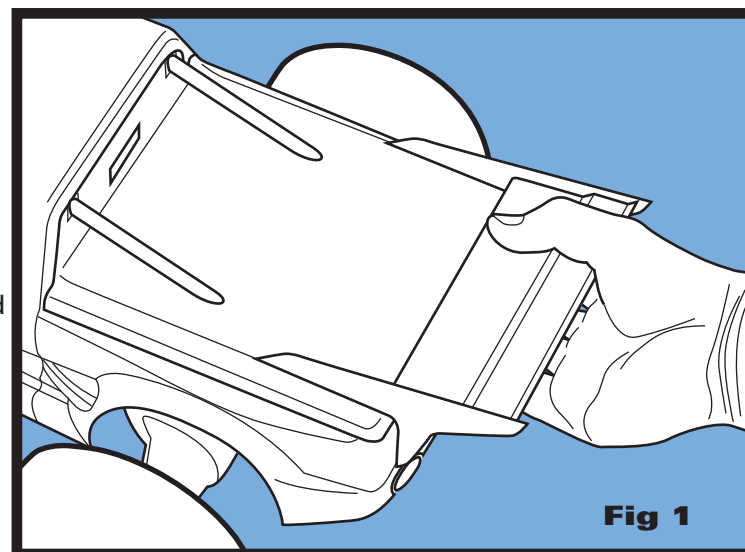

Fig 1

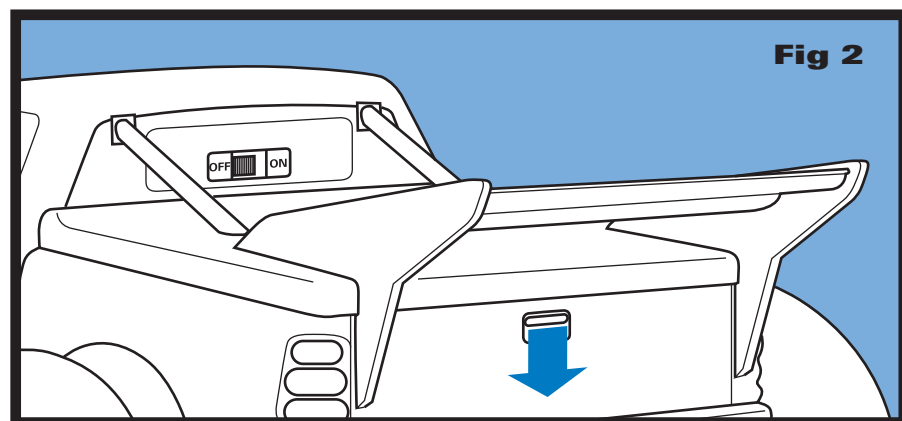

Fig 2

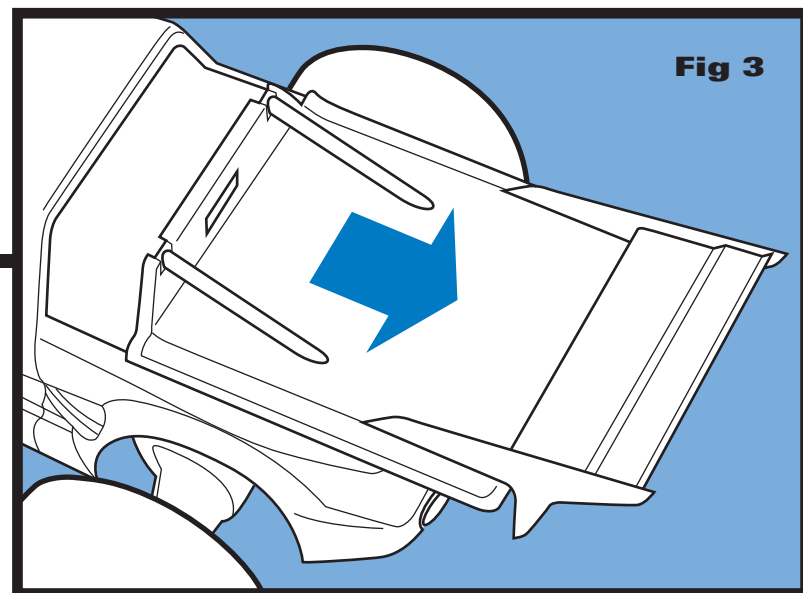

Fig 3

2. Plug BATTERY JACK into VEHICLE JACK as shown. (Fig. 4)
3. Place fully and freshly charged BATTERY PACK into BATTERY COMPARTMENT and place PLUG/JACK/WIRE as shown so they're out of the way when you replace the LID. (Fig. 5)
4. Replace BATTERY LID and press into place until LATCH secures it in place. (Fig. 6)

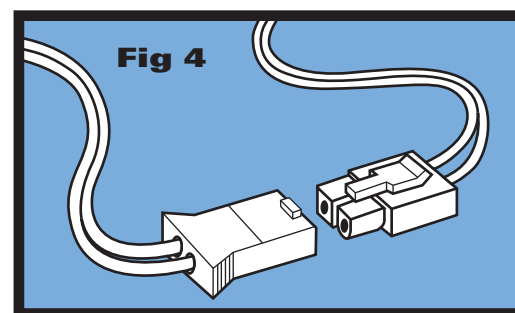

Fig 4

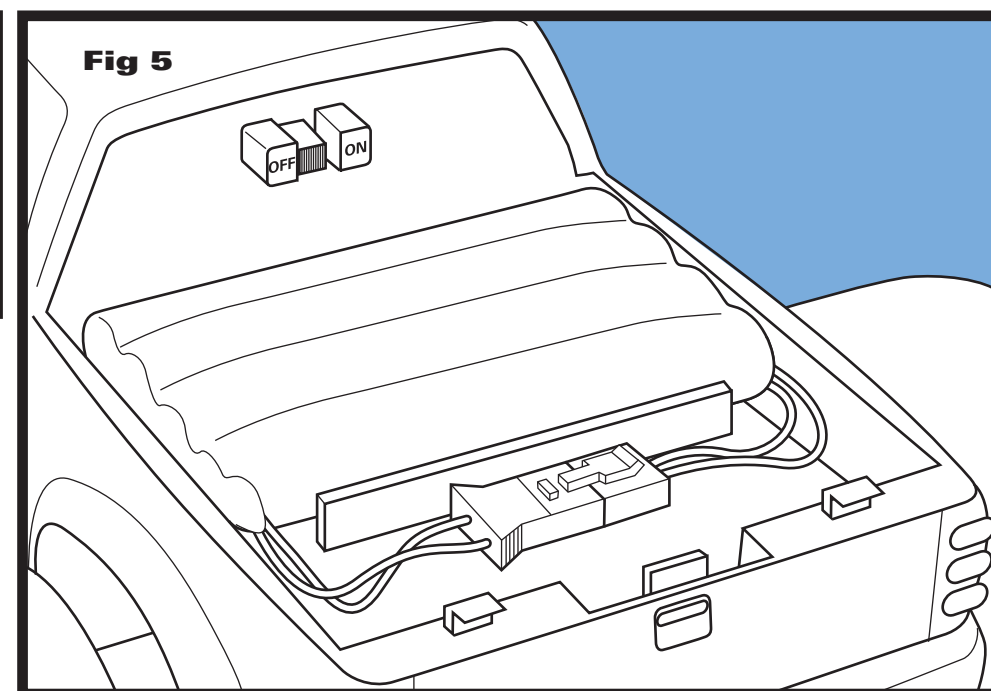

Fig 5

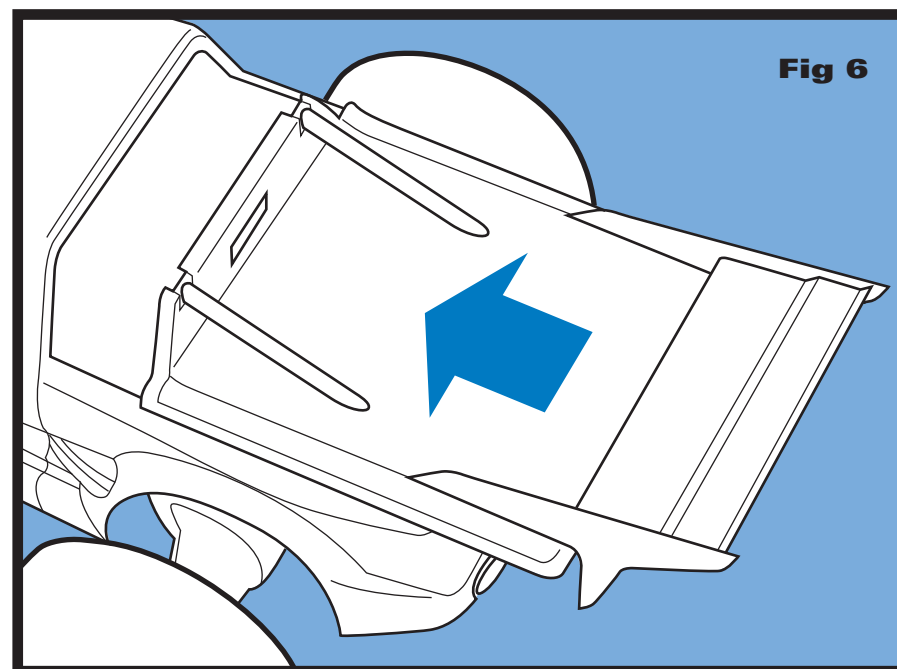

Fig 6

Transmitter Battery Installation

1. Slide open BATTERY DOOR on back of TRANSMITTER. (Fig. 7)
2. Insert a fresh, new 9-VOLT ALKALINE BATTERY with the polarity (+/-) as shown on the bottom of battery compartment. (Fig. 8)
3. Hold battery in place with thumb and replace BATTERY DOOR. (Fig. 9)
4. Check for transmitter operation by looking for the red "POWER ON" LIGHT on front to light when a JOYSTICK is pushed. If LIGHT does not come on, check battery polarity. If LIGHT still does not light, install a brand-new battery.

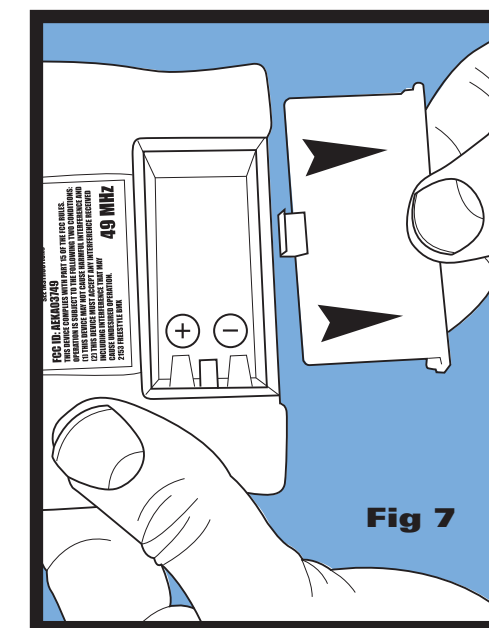

Fig 7

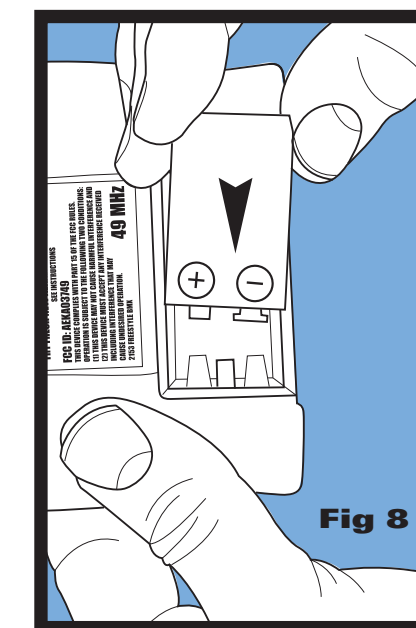

Fig 8

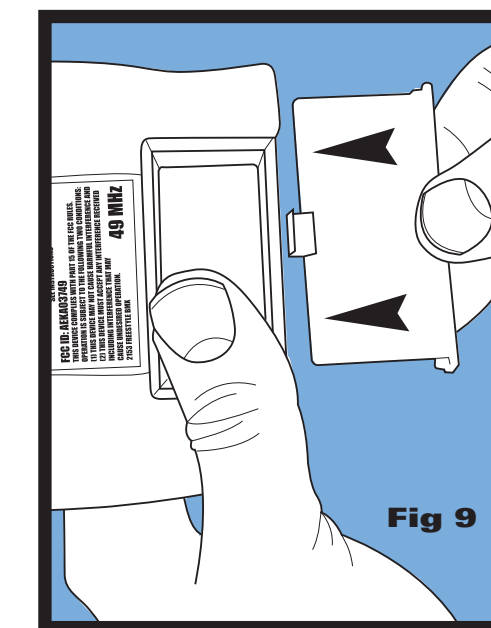

Fig 9

Transmitter Operation

1. LEFT STICK controls POWER. Move stick up to go forward. Release to coast. Move down to brake or go in reverse. "PULSE" THE STICK (rapid push up-release-push up-release) for slower speeds and better maneuverability.
2. RIGHT STICK is STEERING. Move stick to left to turn left, release to go straight, to right to go right.

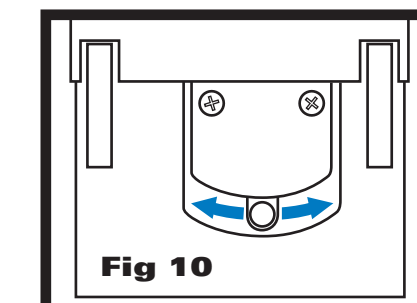
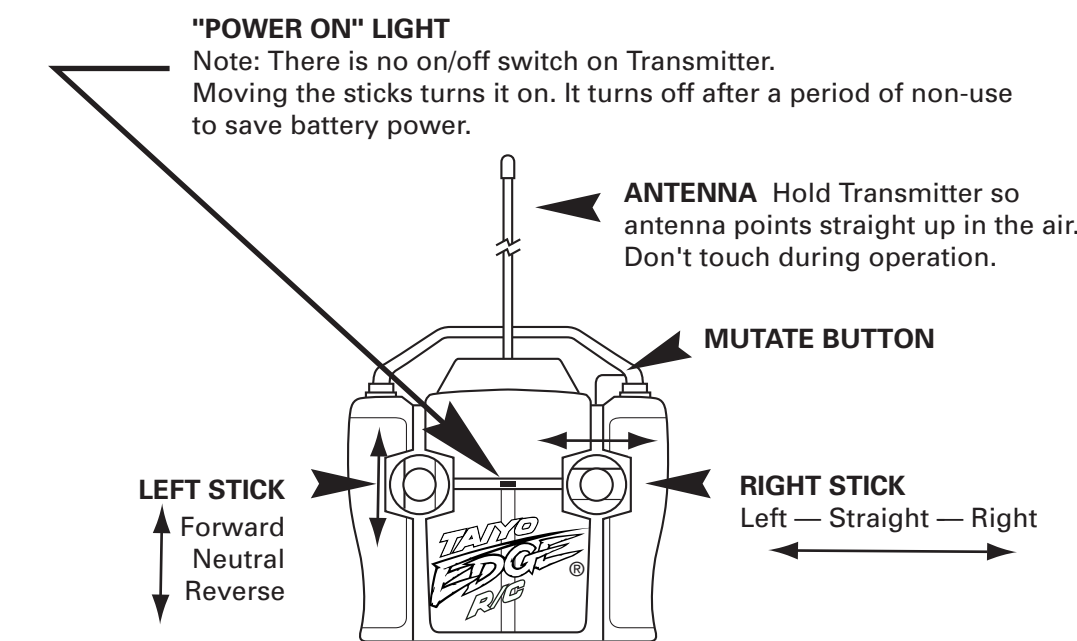

Fig 10

TRIM CONTROL: If vehicle steers to one side when you release the right stick, move TRIM CONTROL on bottom of vehicle slightly in the opposite direction to correct. (Fig. 10) Test (with the vehicle driving away from you) and readjust if needed.

Mutation Operation

MUTATE BUTTON on back of transmitter controls MUTATE ACTION. Press to cycle through the 4 main MUTATE POSITIONS and everything in between. Release button when desired position is reached. If you miss the exact position you want, just press again until it comes around again. Start with the MAIN 4 MUTATE positions and invent your own ENERGETICALLY ENGINEERED MUTATIONS! See next page for Stunt Guide.

Mutator Stunt Guide

Choosing a Stunt Location

1. Operate your Mutator only in a safe location away from traffic, people, pets, cars, obstacles, water and anything else that it could come in contact with. Make sure there is also a safe location for you to stand while you operate your vehicle.
2. Choose an area with lots of open space that is flat, smooth and clean.
3. Always have proper permission to use the location and obey all signs, regulations and laws.
4. Be careful when performing jumps. Make sure no people or pets are near.
5. Clean up when finished. Do not leave ramps or your other materials behind.
6. When in doubt, ask local authorities if it's OK to use the location.

Mutation and Stunt Performance

- Infinite variety of positions in the Mutation cycle
- Experiment with positions to tune vehicle for specific terrains or desired stunt action
- Suspension can be set by selection of Mutation position:
 - Low for firm/road-racing--flat, smooth, hard surface
 - High for soft/long travel--off-roading
- Steering performance can be enhanced with position/center of gravity adjustment
 - Low center of gravity for best steering, slalom, maneuverability, rollover resistance
 - High center of gravity for rollovers/tumbles/sick tricks
- Spinning and stunt action can be optimized with a shorter wheelbase Mutation position

JUMP MODE

Air grabbin'

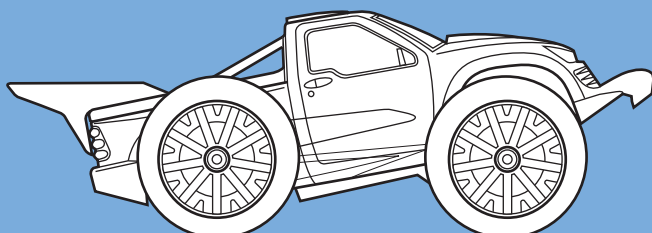

MONSTER MODE

Dirt poundin'

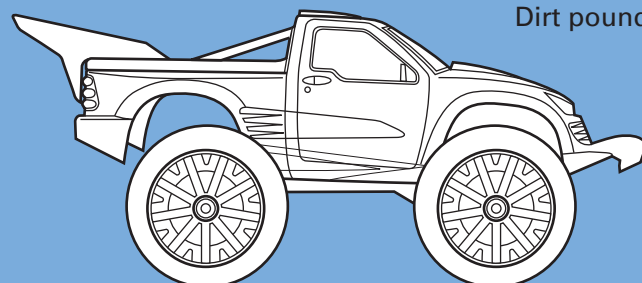

RACER MODE

Ground huggin'

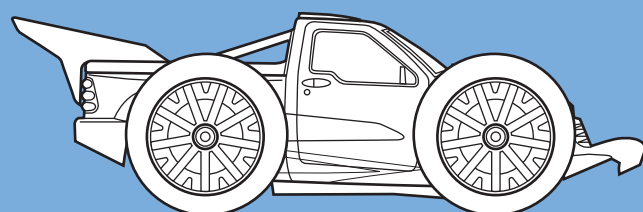

STUNT MODE

Wheelie poppin'

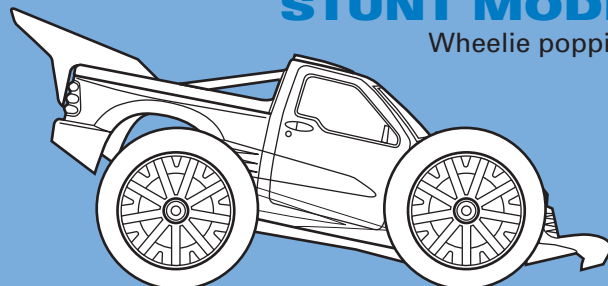

Mutator Tips

1. In order to race or operate two vehicles together, one must be 27MHz and one must be 49MHz. Before you run two R/C vehicles together, check to make sure you have one of each frequency.

AUTO SHUTDOWN

Mutator has electronic protection circuitry that may shut it off during operation. Just release both joysticks for a few seconds to reset.

R/C Facts for Improved Operation

1. When battery start to fully discharge, vehicle may slow, stop, or refuse to respond to your control. It's time to recharge vehicle battery or replace transmitter battery. *This is absolutely the #1 cause of all problems and questions!*
2. Radio frequency interference can interfere with the control of your vehicle. Buildings, power wires, other R/C transmitters, or CB radio can all cause problems. Pick a place to drive that's away from these things.
3. Hold Transmitter so antenna points up, not toward the vehicle. Keep vehicle within range (about 65 feet) to keep control. If vehicle goes out of range, try lifting transmitter high into air to increase range for vehicle recovery.
4. Wipe vehicle clean and dry after each use, including inside battery compartments.
5. Turn vehicle power switch off immediately after running. Remove batteries for storing. Keep vehicle and Transmitter away from heat and direct sunlight and moisture.

Troubleshooting Guide

Don't take your Mutator back to the store--try solving problems using this valuable guide.

Problem	Probable Cause	Correction
Vehicle runs slowly, or won't move, or won't steer	<ul style="list-style-type: none"> • Batteries dead or low charge • Batteries installed incorrectly • Loose battery connection • Power switch is off 	<ul style="list-style-type: none"> • Remove and replace batteries, making sure battery direction (polarity, +/-) is correct and battery compartment contacts, plug and socket are clean. • Recharge vehicle battery. • Replace transmitter battery. • Turn on Power switch.
Erratic operation, loss of control, short range	<ul style="list-style-type: none"> • Radio interference • Weak Transmitter battery 	<ul style="list-style-type: none"> • Move to another location. • Point antenna up in the air, not at vehicle. Don't touch antenna. • Recharge 9.6V battery pack and/or replace 9V alkaline battery in transmitter.
Vehicle stops working after going through water, mud or snow	<ul style="list-style-type: none"> • Water in battery/electronics/motor areas <p>DO NOT RUN VEHICLE IN WATER OR RAIN—WARRANTY MAY BE VOIDED</p>	<ul style="list-style-type: none"> • Turn power switch off IMMEDIATELY, remove battery pack, dry inside and out with clean soft cloth and allow to dry overnight with battery door open. • Avoid wet surfaces, puddles, rain and snow

COMPLIANCE WITH FCC REGULATIONS

THIS DEVICE COMPLIES WITH PART 15 OF FCC RULES. OPERATION OF THIS DEVICE IS SUBJECT TO THE FOLLOWING TWO CONDITIONS:

- (1) THIS DEVICE MAY NOT CAUSE HARMFUL INTERFERENCE.
- (2) THIS DEVICE MUST ACCEPT ANY HARMFUL INTERFERENCE THAT MAY CAUSE UNDESIRE OPERATION. This device generates and uses radio frequency energy and if not used properly may cause interference to radio and television reception. It has been tested and found to comply with the limits set by the FCC, which are designed to provide reasonable protection against such interference.

CAUTION: FCC Regulations state that changes or modifications to this product not expressly approved by the party responsible for compliance could void the user's authority to operate the equipment.

PRINTED IN CHINA

© 2003 Taiyo Edge Ltd. Co., P.O. Box 1470, New Smyrna Beach, FL 32170, U.S.A. All Rights Reserved. U.S. Patent 5,762,533. EP 0782874. Other U.S. and Foreign Patents Pending. Product specifications subject to change. Product may differ from illustrations. **2350-US**

TAIYO
EDGE
R/C

MUTATOR



Taiyo Edge® R/C Consumer Service
We want to assist you!

DO NOT RETURN THE PRODUCT TO THE STORE!

Log on: Click "Service" at www.taiyoedge.com

E-mail: help@taiyoedge.com

TOLL-FREE CONSUMER HELPLINE

1-866-4-EDGE-RC (1-866-433-4372)

OWNER'S MANUAL

SAVE THESE INSTRUCTIONS FOR FUTURE REFERENCE. THEY CONTAIN IMPORTANT INFORMATION.

Important! Please read your Owner's Manual all the way through before operating your vehicle.

Safety First

- Adult supervision is recommended.
- Drive your vehicle in a safe area away from people, pets, cars, etc. Not in streets, in or near water, or in darkness!
- Don't touch or try to pick up vehicle when it is in motion or while it is mutating. Wait until it stops completely. Never pick up by the wheels.
- Keep hair, fingers, face and loose clothing away from wheels while the vehicle is switched on or while the transmitter is operating.

• Be a responsible Mutator® operator! **DO NOT RUN VEHICLE IN WATER OR RAIN—WARRANTY WILL BE VOIDED**

Batteries and Charger Required (9.6V Battery Pack and Charger included only with Mutator model no. 2351; not included with model no. 2350. Retailer decides which version to carry.)

1. 9.6-Volt Rechargeable NiCd or NiMH Battery Pack (commonly available for R/C vehicles at many toy and hobby dealers). For longer run time, use high-capacity "NiMH" (Nickel-Metal Hydride) or "NiCd" (Nickel-Cadmium) battery packs with highest "mAh" rating number (750mAh or higher).

2. Matching Battery Charger for NiMH or NiCd Battery Packs. (Adult supervision of recharging is recommended)

3. One 9-Volt Alkaline Battery for Transmitter required, not included (not rechargeable).

IMPORTANT BATTERY SAFETY INFORMATION

Battery Cautions

CAUTION: TO AVOID BATTERY LEAKAGE

- Make sure the batteries are inserted with the correct polarity and follow the toy and battery manufacturers' instructions.
- Do not mix old and new batteries.
- Do not mix alkaline, standard (carbon-zinc), or rechargeable (nickel-cadmium, nickel-metal hydride) batteries, or different types of rechargeable batteries.
- Remove weak or exhausted batteries from the product. **Remove batteries from product when not in use.**

ADDITIONAL IMPORTANT BATTERY SAFETY INFORMATION

- An adult should help with battery replacement.
- Only batteries of the same or equivalent type as recommended in the "Battery Installation" (or replacement) instructions are to be used.
- Non-rechargeable batteries are not to be recharged.
- If removable rechargeable batteries are used, they are only to be charged under adult supervision.
- Rechargeable batteries are to be removed from the product before they are charged.
- If you use a battery charger, it should be examined regularly for damage to the cord, plug, enclosure and other parts. Do not use a damaged battery charger until it has been properly repaired.
- Dispose of batteries safely and properly.

NOTE: NICKEL CADMIUM BATTERIES MUST BE RECYCLED OR DISPOSED OF PROPERLY.

Contact your local area office of solid waste management or other appropriate local agency for information.



Ni-Cd