

**TEAM
EDGE
R/C**

**FREESTYLE
ATV**

Team Edge® R/C Consumer Service
We want to assist you!

DO NOT RETURN THE PRODUCT TO THE STORE!

Log on: Click "Help" at www.teamedge.com

E-mail: help@teamedge.com

TOLL-FREE CONSUMER HELPLINE
1-866-4-EDGE-RC (1-866-433-4372)



OWNER'S MANUAL

Important! Please read your Owner's Manual all the way through before operating your vehicle. Contains important information keep for future reference.

Safety First

- Adult supervision is recommended.
- Drive your vehicle in a safe area away from people, pets, cars, etc. Not in streets, not in dark, not in or near water!
- Don't touch or try to pick up vehicle when it is in motion. Wait until it stops completely.
- Keep hair, fingers, face and loose clothing away from the wheels, spokes and tires while the vehicle is switched on or while the transmitter is operating.
- Be a responsible Freestyle™ ATV operator!

Batteries Required (not included)

6 "AA" Alkaline (or Rechargeable) Cells for ATV and One 9-Volt Battery for Transmitter.

(See below for information on rechargeable batteries. Rechargeable batteries and charger not included.)

Battery Cautions

CAUTION: TO AVOID BATTERY LEAKAGE

1. Make sure the batteries are inserted correctly and follow the toy and battery manufacturer's instructions.
2. Do not mix old and new batteries.
3. Do not mix alkaline, standard (carbon-zinc), or rechargeable (nickel-cadmium, nickel-metal hydride, rechargeable alkaline) batteries.
4. Remove weak or exhausted batteries from product.

More Important Battery Information

- Start with all new batteries and always replace ALL 6 vehicle batteries at the same time.
- Make sure battery polarity (direction) is correct.
- Use only battery type(s) recommended.
- Remove batteries from the product if it will not be used for a long period of time.
- Battery life may vary with the brand used.
- Do not recharge non-rechargeable batteries.
- Remove rechargeable batteries from the product before charging. Recharge batteries only under adult supervision and follow the battery and charger manufacturers' instructions.
- Do not short-circuit battery terminals.
- Keep vehicle and transmitter dry. If they get wet, immediately turn off power switch and remove batteries, wipe off excess moisture, and allow to air dry for at least 24 hours.
- Dispose of batteries safely and properly.

Using Rechargeable Cells (Batteries and Charger not included.) Rechargeable "AA" size batteries may be used in ATV. You'll still need to purchase a 9-volt alkaline battery for the transmitter. For safety and battery charging information, please read and follow the instructions that came with your rechargeable batteries and recharger. Adult supervision of battery charging is recommended.

COMPLIANCE WITH FCC REGULATIONS

THIS DEVICE COMPLIES WITH PART 15 OF FCC RULES. OPERATION OF THIS DEVICE IS SUBJECT TO THE FOLLOWING TWO CONDITIONS:

- (1) THIS DEVICE MAY NOT CAUSE HARMFUL INTERFERENCE, AND
- (2) THIS DEVICE MUST ACCEPT ANY HARMFUL INTERFERENCE THAT MAY CAUSE UNDESIRABLE OPERATION.

This device generates and uses radio frequency energy and if not used properly may cause interference to radio and television reception. It has been tested and found to comply with the limits set by the FCC, which are designed to provide reasonable protection against such interference.

CAUTION: FCC Regulations state that changes or modifications to this product not expressly approved by the party responsible for compliance could void the user's authority to operate the equipment.

"Smart Circuitry"

Your precision Freestyle ATV is equipped with advanced circuitry designed to protect electronic components under extreme operating conditions. If ATV stops running during use, simply allow the joysticks to return to their neutral positions for 15 to 20 seconds, then resume normal operation.

R/C Facts

1. When batteries start to wear down, ATV may slow, stop, or refuse to respond to your control. It's time to replace ALL 6 vehicle batteries and transmitter battery. *This is absolutely the #1 cause of problems!*
2. Useful Driving Tip: "Pulse" the left stick (by moving it rapidly up and back to center "coasting" position) to achieve slower speeds and help control the handling of your ATV.
3. Your ATV runs on either 27MHz frequency or 49MHz frequency (see frequency labels on vehicle and transmitter). In order to race or run 2 vehicles together, they must be on different frequencies.
4. Transmitter has a range of about 35 feet. Don't drive too far or you may lose control of your ATV. If vehicle goes out of range, try lifting transmitter high into air to temporarily increase range.
5. Radio interference can interfere with the control of your ATV. Buildings, power wires, other R/C transmitters, or CB radio can all cause problems. Pick a place to drive that's away from these things.
6. Hold Transmitter so antenna points up, not toward the vehicle. Keep ATV within range to keep control.
7. **WATER, SNOW AND SAND CAN CAUSE PROBLEMS. KEEP AWAY FROM THEM.**
Wipe ATV clean and dry after each use, including inside battery compartments. Clothing can be hand washed in cold water with mild soap and air dried.
8. Turn ATV switch off immediately after running. Remove batteries for storing.
9. Keep ATV and Transmitter away from heat and direct sunlight.

Troubleshooting Guide

Problem	Probable Cause	Correction
Vehicle will not move or steer compartment	<ul style="list-style-type: none"> • Battery Problems • Batteries dead or low • Batteries installed incorrectly • Loose battery connection • ATV switch is off • "Smart Circuitry" protection has kicked in 	<ul style="list-style-type: none"> • Remove and replace ALL 6 vehicle batteries, making sure battery direction (polarity, +/-) is correct and battery contacts are clean. • Replace ALL 6 vehicle batteries and transmitter battery with fresh, new alkaline batteries or recharge rechargeable cells. • Turn on ATV switch. • Release both sticks for 15-20 seconds, then resume
ATV will not steer	<ul style="list-style-type: none"> • Debris caught in front wheels / axles • Transmitter or vehicle batteries low 	<ul style="list-style-type: none"> • Remove debris caught in front wheels and axles • Replace ALL 6 vehicle batteries and transmitter battery with fresh, new alkaline batteries OR recharge rechargeable cells.
Erratic operation, loss of control, short range	<ul style="list-style-type: none"> • Radio interference • Antenna pointed at vehicle • Touching antenna • Weak Transmitter battery • Weak ATV batteries 	<ul style="list-style-type: none"> • Move to another location. • Point antenna up in the air, not at vehicle. • Don't touch antenna. • Replace ALL 6 vehicle batteries and transmitter battery with fresh, new alkaline cells OR recharge rechargeable cells.
ATV stops working after going into water or snow	<ul style="list-style-type: none"> • Water in battery, electronics and motor areas <p>DO NOT OPERATE IN WET CONDITIONS!</p>	<ul style="list-style-type: none"> • IMMEDIATELY turn ATV off, remove all batteries, dry inside and out with clean soft cloth, and allow to dry overnight with battery doors off.

90-Day LIMITED WARRANTY ON TEAM EDGE® R/C VEHICLE AND TRANSMITTER - VALID IN U.S. AND CANADA ONLY

WHAT'S COVERED AND HOW LONG THE COVERAGE LASTS Taiyo Edge Ltd. Co. warrants to the original U.S. or Canadian retail purchaser of its radio control vehicle and transmitter that the product is free from defects in materials and workmanship for the period of ninety (90) days after the date of retail purchase.

WHAT WE WILL DO We will repair or replace the product, at our option, at our consumer service center if a defect is discovered during the warranty period, subject to verification of the defect or malfunction and the date of purchase. This is our sole and exclusive liability to you.

HOW TO GET HELP Allow us to help you. Please do not return the product to the store where it was purchased. We want to satisfy you whenever you buy a Team Edge product.

1) Log on to the Internet to www.teamedge.com and click on "Help" for information on how to solve your problem and/or obtain service.

2) Send an e-mail to "help@teamedge.com," giving the name of the toy and briefly describing the problem, to get information on solving the problem and/or obtaining service.

3) Call our toll-free Helpline number **1-866-4-EDGE-RC (1-866-433-4372)** in the U.S. or Canada only for fast help and/or information on obtaining service.

Most problems can be solved by contacting us!

HOW TO GET WARRANTY SERVICE If the product requires warranty service, CONTACT US BY PHONE OR E-MAIL FIRST. NO PRODUCT SHOULD BE RETURNED TO US WITHOUT AUTHORIZATION. *We will not be responsible for products returned without authorization.* Upon receiving authorization from us, pack the product carefully and send it postage prepaid to the address below. Enclose your name, address, telephone number, a brief description of the defect, a copy of your dated sales receipt with the purchase price circled, and the date of authorization. We recommend you insure the parcel for its full retail value. We will return the product to you postage prepaid.

WHAT'S NOT COVERED This warranty does not apply to defects arising from abuse, alteration or unreasonable use of the product, or any claim arising from worn, defective or leaking batteries. Any applicable implied warranty, including warranties of merchantability and fitness for a particular purpose, are hereby limited to 90 days from the date of purchase. Consequential, incidental or contingent damages resulting from a breach of any applicable express or implied warranties are excluded.

YOUR LEGAL RIGHTS This Warranty gives you specific rights, which may vary from state to state. Some states do not allow limitations on how long an implied warranty lasts or the exclusion or limitation of consequential, incidental or contingent damages, so depending on where you live, the above limitations and exclusions may not apply to you.

TAIYO EDGE LTD. CO., P.O. BOX 1470, NEW SMYRNA BEACH, FL 32170 U.S.A.

PRINTED IN CHINA

© 2002 - 2004 Taiyo Edge Ltd. Co., P.O. Box 1470, New Smyrna Beach, FL 32170, U.S.A. All Rights Reserved. U.S. and Foreign Patents Pending. TEAM EDGE is a registered trademark in the U.S., Australia and Japan. Product specifications subject to change. Product may differ from illustrations. ATV-US

ATV Battery Installation

1. Slide BATTERY LATCH toward rear of vehicle to unlock. Pull BATTERY HOLDER out of bottom of chassis. (Fig. 1, 2)

2. Insert 3 FRESH, NEW "AA" ALKALINE BATTERIES into one side of HOLDER in the directions shown on inside of battery compartment and in Fig. 2.

IMPORTANT: OBSERVE BATTERY POLARITY (DIRECTION, (+) AND (-))

3. Turn HOLDER around and insert 3 FRESH, NEW "AA" ALKALINE BATTERIES into the other side of HOLDER in the directions shown on inside of battery compartment and in Fig. 2.

NOTE: BATTERY DIRECTION IS THE SAME ON BOTH SIDES OF THE HOLDER.

4. Replace HOLDER into chassis THE SAME WAY IT CAME OUT. Slide LATCH toward front of vehicle to lock.

IMPORTANT: IF HOLDER DOES NOT LATCH OR STAY IN, IT HAS BEEN INSERTED IN THE WRONG DIRECTION. REMOVE AND REPLACE IT IN THE CORRECT DIRECTION.

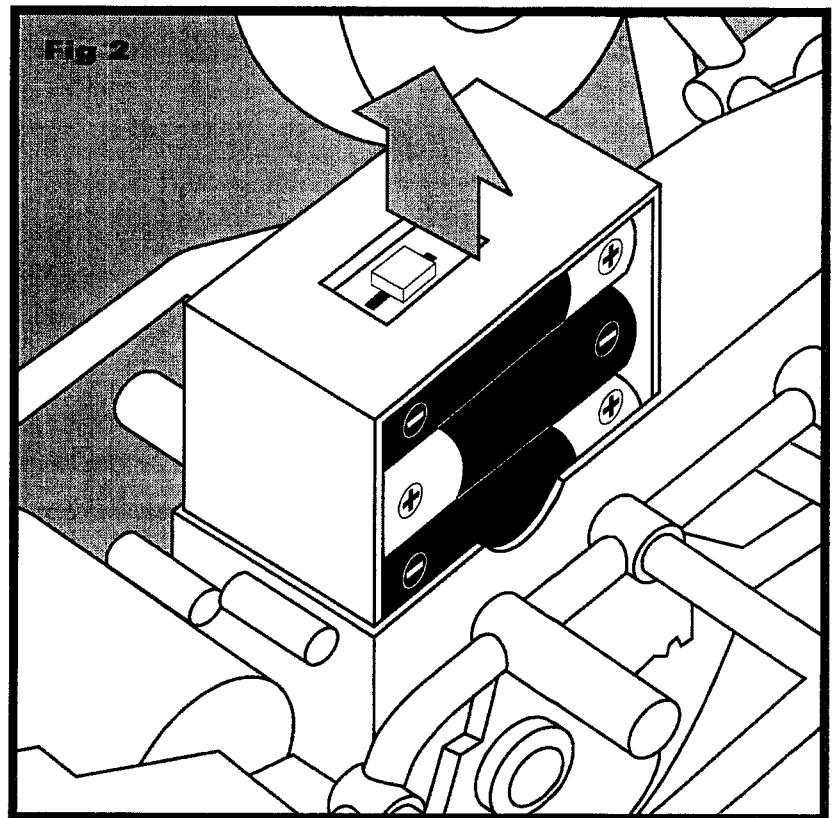
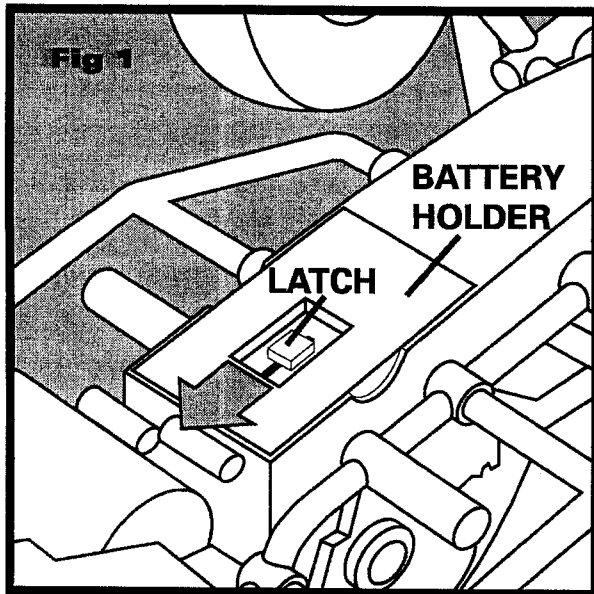

Transmitter Battery Installation

1. Slide open BATTERY DOOR on back of TRANSMITTER (Fig. 4)

2. Insert a fresh, new 9-VOLT ALKALINE BATTERY with the polarity (+/-) as shown on the bottom of battery compartment (Fig 5).

3. Hold battery in place with thumb and slide battery door all the way closed to secure battery. (Fig. 6).

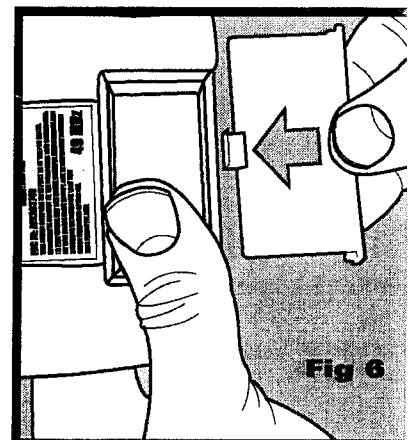
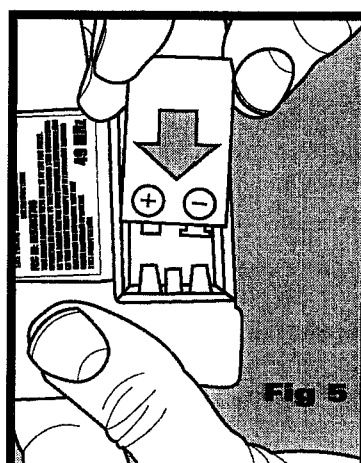
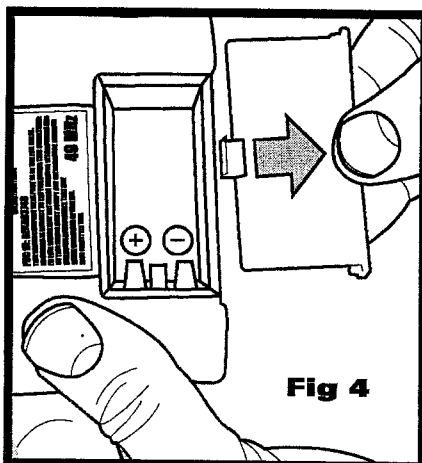

Transmitter Features and Operation

1. **Left stick:** Push up to go forward. Release to coast. Pull down to brake and reverse.

2. **Right stick:** Push left for Left Turn, right for Right Turn. Release to go straight.

3. **Antenna:** Hold Transmitter so antenna points straight up in the air.

Don't touch the antenna during operation.

Note: There is no on/off switch on Transmitter. Moving the sticks turns it on.

Releasing the sticks turns it off (to save battery power).

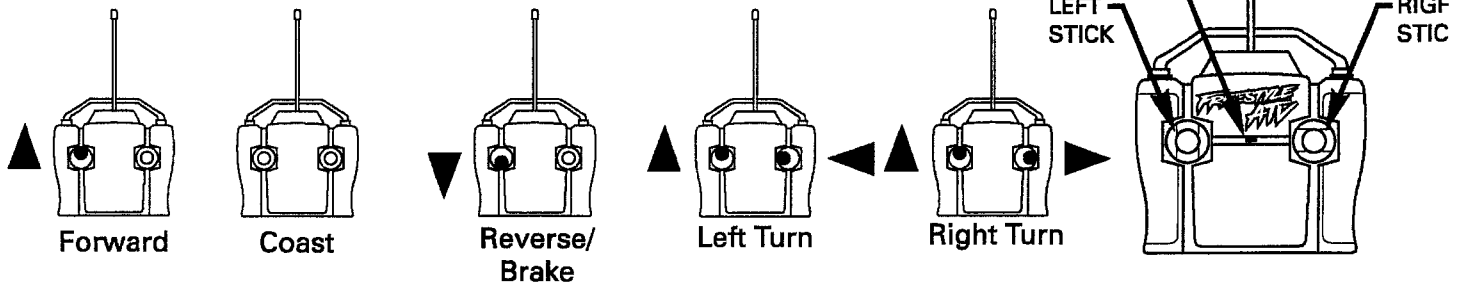

"Pulsing" The Left Stick

REPEATEDLY "PULSE" THE LEFT (THROTTLE) STICK BY RAPIDLY MOVING IT UP AND RELEASING IT, UP AND RELEASE, UP AND RELEASE, ETC., TO CONTROL THE SPEED OF YOUR ATV. SLOWER SPEEDS HELP YOU MAKE SHARPER TURN

Seating Driver

IMPORTANT: DRIVER MUST BE SEATED CORRECTLY FOR PROPER OPERATION, MAKING SURE HANDS, FEET AND CLOTHING DO NOT TOUCH WHEELS OR GROUND.

1. Face Driver's head forward.

2. Swing out PRONGS from bottom of Driver's SHOES as shown. (Fig. 7)

3. Snap PRONG on each shoe over each FOOTPEG. (Fig. 7)

4. Seat Driver in seat. (Fig. 8)

5. Hold WRIST between index and middle fingers as shown (Fig. 9) and place thumb on front of HANDLEGRIP. Squeeze fingers and thumb together to push HAND all the way onto HANDLEGRIP as shown. Repeat for other HAND.

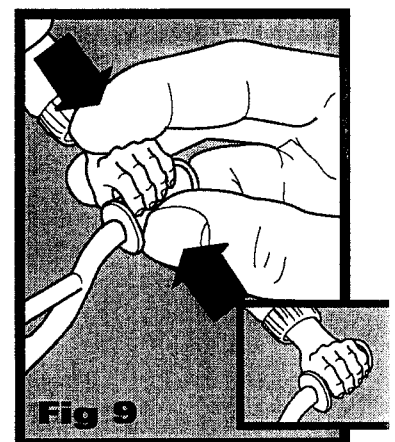
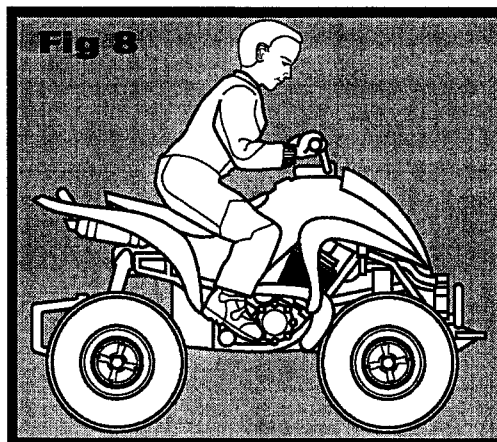
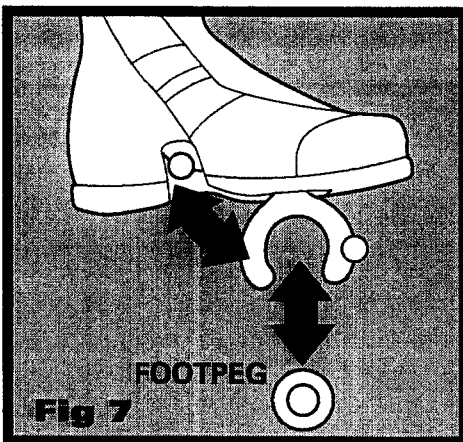

Operation

1. Slide ATV POWER SWITCH to ON position. (Fig. 10) Note: Turn switch off whenever possible to save batteries.

2. If vehicle steers slightly to one side when you release the right stick to go straight, turn the TRIM ADJUSTER on the bottom in the opposite direction, a little at a time.

(Drive vehicle away from you to test.) Repeat if necessary. (Fig. 11)

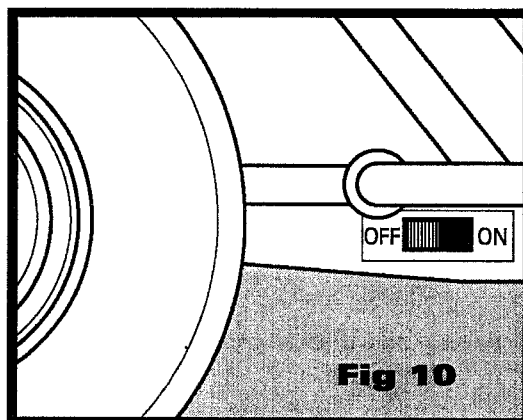

POWER SWITCH

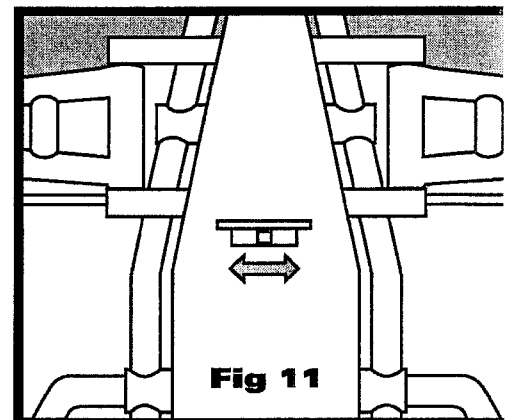

TRIM ADJUSTER