

**TAIYO  
EDGE™  
R/C**

Change to "Freesty Kart"

**MX HAULER™**



Taiyo Edge™ R/C Consumer Service  
We want to assist you!

**DO NOT RETURN THE PRODUCT TO THE STORE!**

Log on: Click "Service" at [www.taiyoedge.com](http://www.taiyoedge.com)

E-mail: [help@taiyoedge.com](mailto:help@taiyoedge.com)

**TOLL-FREE CONSUMER HELPLINE**

**1-866-4-EDGE-RC (1-866-433-4372)**

### **OWNER'S MANUAL**

SAVE THESE INSTRUCTIONS FOR FUTURE REFERENCE. THEY CONTAIN IMPORTANT INFORMATION.

Important! Please read your Owner's Manual all the way through before operating your vehicle.

#### **Safety First**

- Drive your vehicle in a safe area away from people, pets, cars, etc. Not in streets, in or near water, or in darkness!
- Don't touch or try to pick up vehicle when it is in motion. Wait until it stops completely.
- Keep hair, fingers, face and loose clothing away from wheels while the vehicle is switched on or while the transmitter is operating.
- Be a responsible MX Hauler™ operator!

#### **Batteries Required** (not included)

Separate purchase required.

4 "AA" Alkaline Batteries required for vehicle.

One 9-Volt Alkaline Battery required for transmitter.

### **IMPORTANT BATTERY SAFETY INFORMATION**

#### **CAUTION: TO AVOID BATTERY LEAKAGE**

- Make sure the batteries are inserted with the correct polarity and follow the toy and battery manufacturers' instructions.
- Do not mix old and new batteries.
- Do not mix alkaline, standard (carbon-zinc) and rechargeable batteries, or different types of rechargeable batteries (nickel-cadmium, nickel-metal hydride and rechargeable alkaline).
- Remove weak or exhausted batteries from the product.

### **ADDITIONAL IMPORTANT BATTERY SAFETY INFORMATION**

- An adult should help with battery replacement.
- Only batteries of the same or equivalent type as recommended in the "Battery Installation" (or replacement) instructions are to be used.
- Non-rechargeable batteries are not to be recharged.
- If removable rechargeable batteries are used, they are only to be charged under adult supervision.
- Rechargeable batteries are to be removed from the product before they are charged.
- If you use a battery charger, it should be examined regularly for damage to the cord, plug, enclosure and other parts. Do not use a damaged battery charger until it has been properly repaired.
- Dispose of batteries safely and properly.

### **Using Rechargeable Batteries**

(Rechargeable batteries and charger not included)

Rechargeable "AA" batteries can be an economical alternative to alkaline batteries. Look for NiCd (nickel-cadmium) rechargeable cells, or for longer running times, NiMH (nickel-metal hydride) rechargeable cells. Purchase a suitable charger for the type of rechargeable batteries you purchase. Ask your dealer.

Draft

## Battery Installation

1. Slide LATCH on BATTERY DOOR toward rear of vehicle. (Fig. 1)
  2. Open DOOR. (Fig. 2)
  3. Insert 4 fresh, new "AA" Alkaline batteries in the directions shown on the bottom of the battery compartment. (Fig. 3)
- IMPORTANT: OBSERVE BATTERY POLARITY (DIRECTION, + AND -).**
4. Close door, slide latch toward front of vehicle to secure.

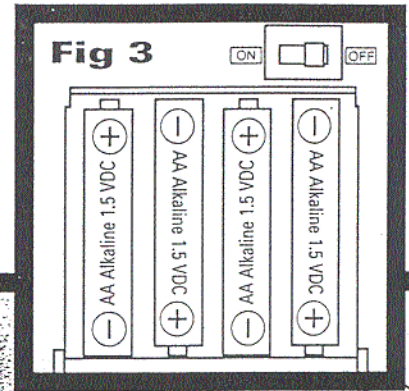
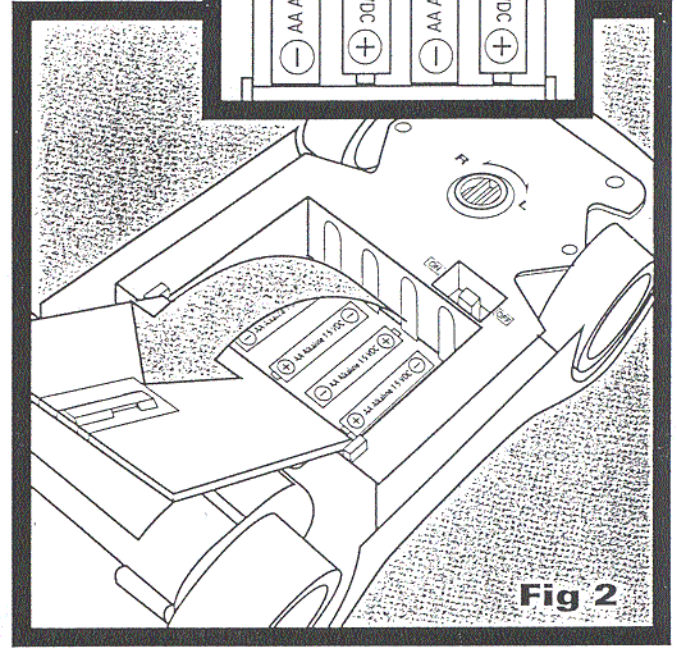
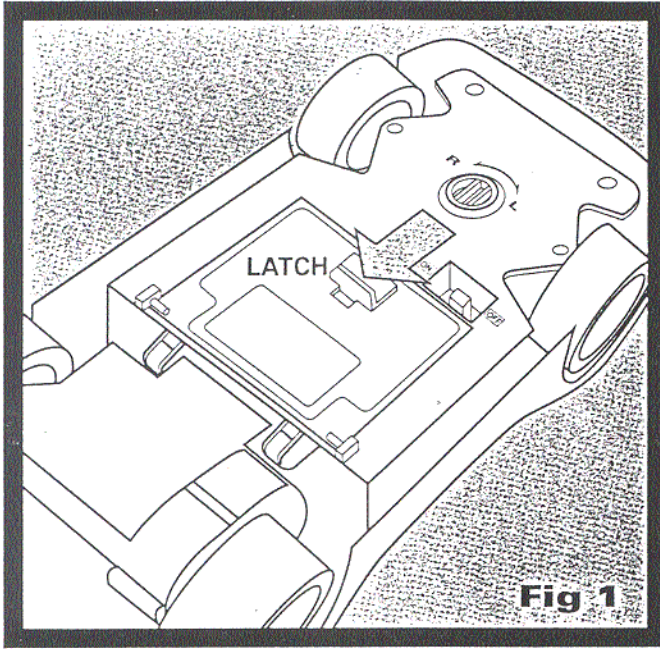

## Transmitter Battery Installation

1. Slide open BATTERY DOOR on back of TRANSMITTER. (Fig. 4)
2. Insert a fresh, new 9-VOLT ALKALINE BATTERY with the polarity (+/-) as shown on the bottom of battery compartment. (Fig. 5)
3. Hold battery in place with thumb and replace BATTERY DOOR. (Fig. 6)

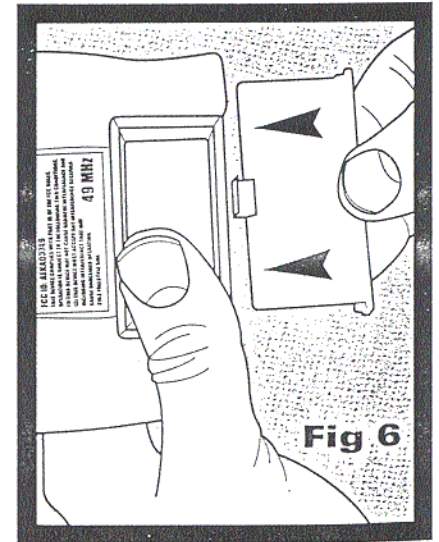
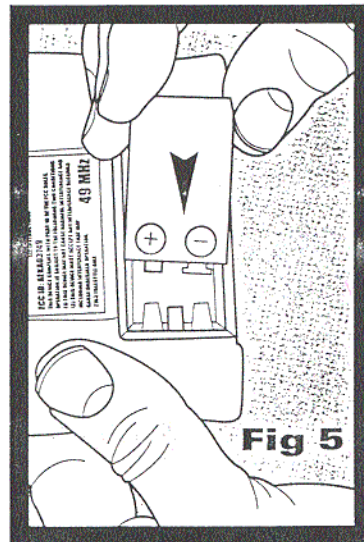
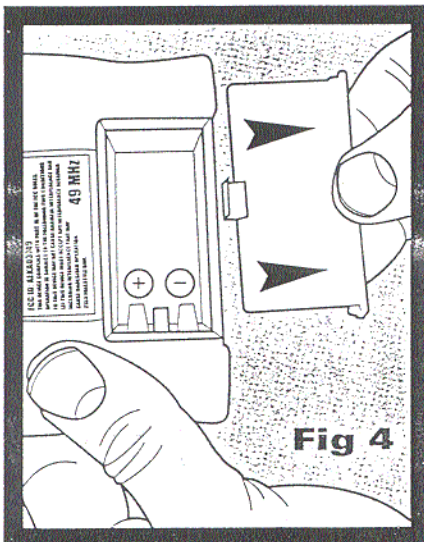

## Transmitter Operation

Note: There is no on/off switch on Transmitter.  
Moving the sticks turns it on. It turns off after a period of non-use.

### LEFT STICK

controls direction/power. Push up to go forward, pull down to go in reverse, release for neutral.

### RIGHT STICK

controls steering. Push left to go left, right to go right. Release to go straight.

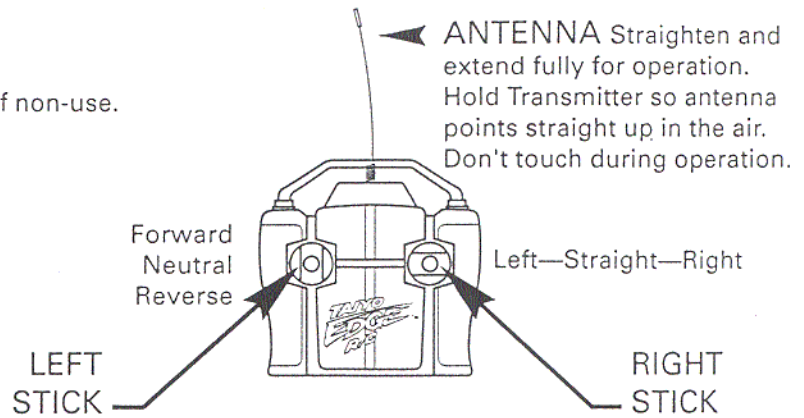

## Vehicle Operation

1. Turn on POWER SWITCH on bottom of vehicle. (Fig. 7)
2. Vehicle operates best on flat, smooth, surfaces. Keep away from water, snow and wet surfaces.
3. If vehicle steers slightly to one side or the other when you release the right stick to go straight, move the TRIM ADJUSTER on the bottom in the opposite direction, a little at a time. (Drive vehicle away from you to test.) Repeat if necessary. (Fig. 7)

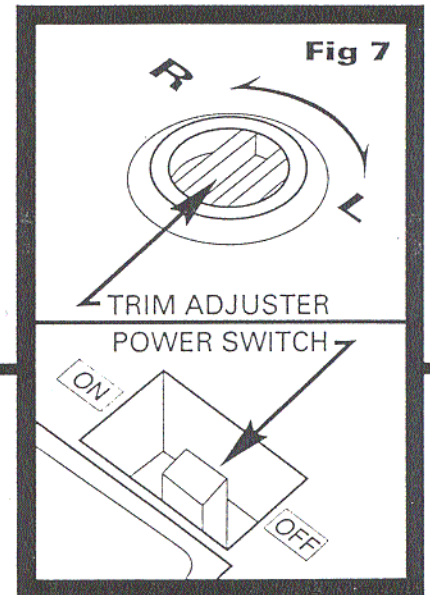

## Attaching Cycle

### To Remove Bike

1. Squeeze LEGS of CLIP together.
2. Slide LEGS rearward to back of SLOTS.
3. While still squeezing, pull CLIP out (Fig. 10).

### To Attach Bike

1. Place WHEELS of Bike in RECESSES (Fig. 9).
2. Place CLIP over Bike.
3. Insert one LEG of CLIP into one SLOT.
4. Squeeze CLIP and insert other LEG into other SLOT.
5. Squeeze LEGS together, slide LEGS forward to front of SLOTS, release.

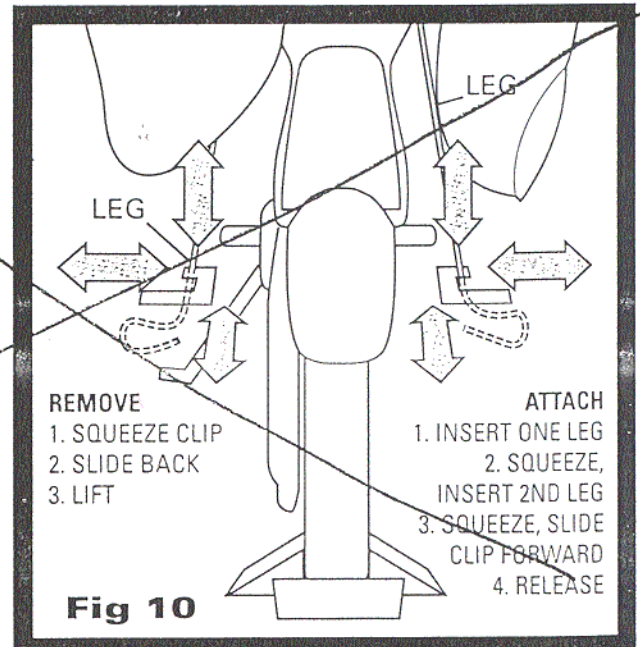
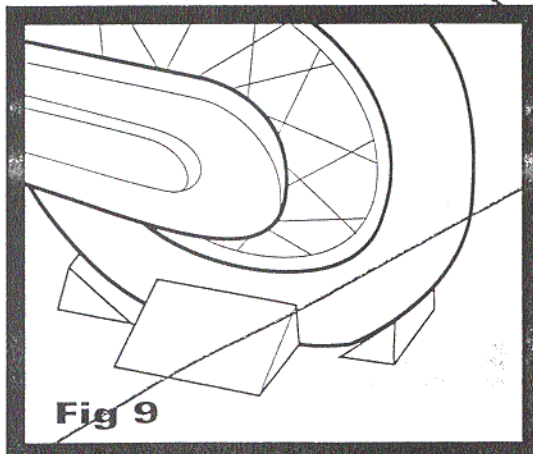

## R/C Tip

In order to race or operate two vehicles together, they must be different frequencies. Check the bottom of your vehicle for the frequency label. Your MX Hauler™ is 27MHz. Look for the Taiyo Edge™ Surf Bug™ (sold separately) at your dealer for a great 49MHz vehicle to run your MX Hauler™ with!

## R/C Facts for Improved Operation

1. When batteries start to discharge, vehicle may slow, stop, or refuse to respond to your control. It's time to replace all 4 vehicle batteries and/or transmitter battery. This is absolutely the #1 cause of all problems and questions! Observe polarity when replacing batteries.
2. Radio frequency interference can interfere with the control of your vehicle. Buildings, power wires, other R/C transmitters, or CB radio can all cause problems. Pick a place to drive that's away from these things.
3. Hold Transmitter so antenna points up, not toward the vehicle. Keep vehicle within range (about 50 feet) to keep control. If vehicle goes out of range, try lifting transmitter high into air to increase range.
4. Wipe vehicle clean and dry after each use, including inside battery compartments.
5. Turn vehicle power switch off immediately after running. Remove batteries for storing or shipping. Keep vehicle and Transmitter away from heat and direct sunlight and moisture.

## Troubleshooting Guide

Don't take your vehicle back to the store--try solving problems using this valuable guide.

Problem	Probable Cause	Correction
Vehicle runs slowly, or won't move, or won't steer	<ul style="list-style-type: none"><li>• Batteries dead or low</li><li>• Batteries installed incorrectly in vehicle or transmitter</li><li>• Loose battery connection</li><li>• Dirty battery or battery compartment contacts</li><li>• Power switch is off</li></ul>	<ul style="list-style-type: none"><li>• Install 4 fresh, new "AA" alkaline cells.</li><li>• Remove and replace batteries, making sure battery direction (polarity, +/-) is correct and battery and battery box contacts are clean.</li><li>• Replace transmitter battery.</li><li>• Turn on Power switch.</li></ul>
Erratic operation, loss of control, short range	<ul style="list-style-type: none"><li>• Radio interference</li><li>• Loose or curled transmitter antenna</li><li>• Antenna touching hands or body</li><li>• Weak transmitter battery</li><li>• Weak vehicle batteries</li></ul>	<ul style="list-style-type: none"><li>• Move to another location.</li><li>• Straighten antenna to extend fully. Point up in the air, not at vehicle.</li><li>• Don't touch antenna.</li><li>• Replace all 4 vehicle batteries and/or transmitter battery.</li></ul>
Vehicle stops working after going through water or snow	<ul style="list-style-type: none"><li>• Water in battery/electronics/motor areas</li></ul>	<ul style="list-style-type: none"><li>• Turn power switch off IMMEDIATELY, remove batteries, dry inside and out with clean soft cloth and allow to dry overnight with battery door open. Always avoid wet surfaces, puddles or rain.</li></ul>

## COMPLIANCE WITH FCC REGULATIONS

THIS DEVICE COMPLIES WITH PART 15 OF FCC RULES. OPERATION OF THIS DEVICE IS SUBJECT TO THE FOLLOWING TWO CONDITIONS:

- (1) THIS DEVICE MAY NOT CAUSE HARMFUL INTERFERENCE.
- (2) THIS DEVICE MUST ACCEPT ANY HARMFUL INTERFERENCE THAT MAY CAUSE UNDESIRE OPERATION.

This device generates and uses radio frequency energy and if not used properly may cause interference to radio and television reception. It has been tested and found to comply with the limits set by the FCC, which are designed to provide reasonable protection against such interference.

CAUTION: FCC Regulations state that changes or modifications to this product not expressly approved by the party responsible for compliance could void the user's authority to operate the equipment.

PRINTED IN CHINA

© 2001 Taiyo Edge Ltd. Co., P.O. Box 1470, New Smyrna Beach, FL 32170, U.S.A. All Rights Reserved. Taiyo Edge, Surf Bug and MX Hauler are licensed trademarks of Tilbor Marketing and Development Inc. Product specifications subject to change. Product may differ from illustrations.