

**SPARCI!**<sup>TM</sup>

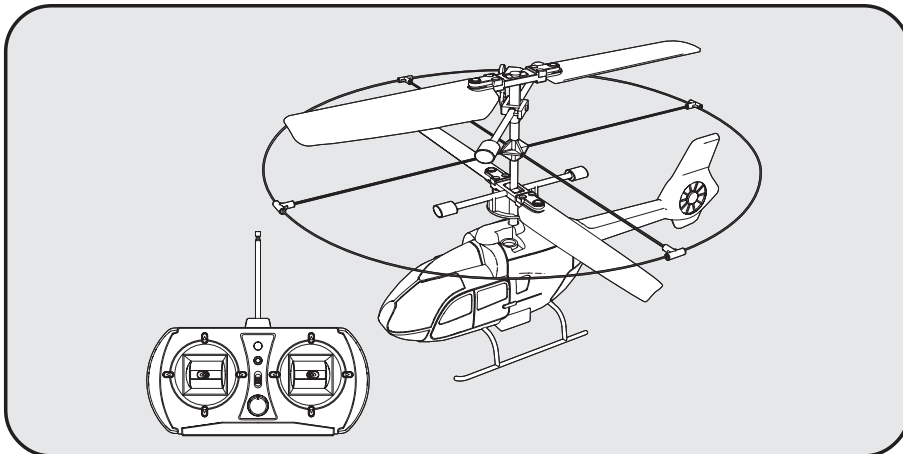

# AEROLITE RADIO CONTROL MICRO HELICOPTER



**ENG**

**OWNER'S MANUAL**

Keep these instructions for future reference as they contain important information.

**I**

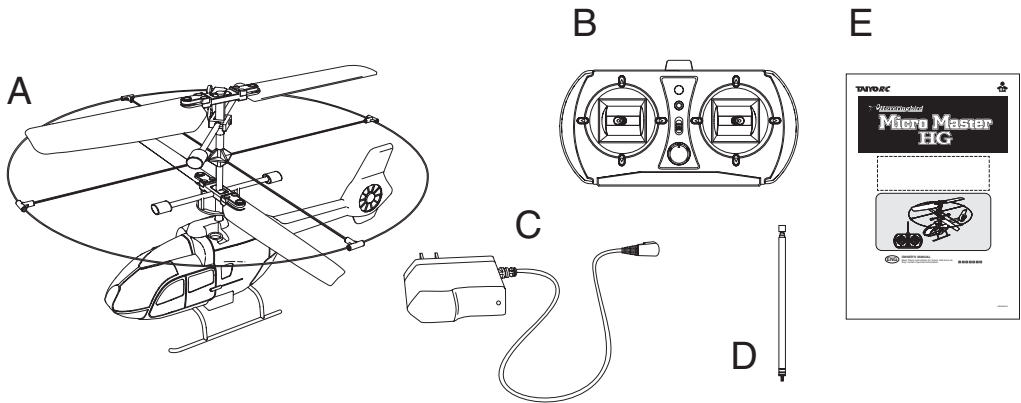

**1**

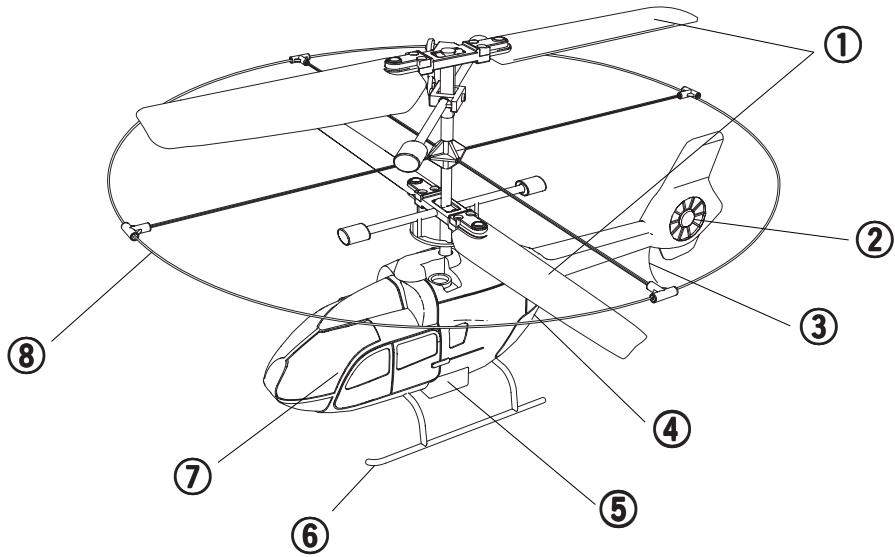

**2**

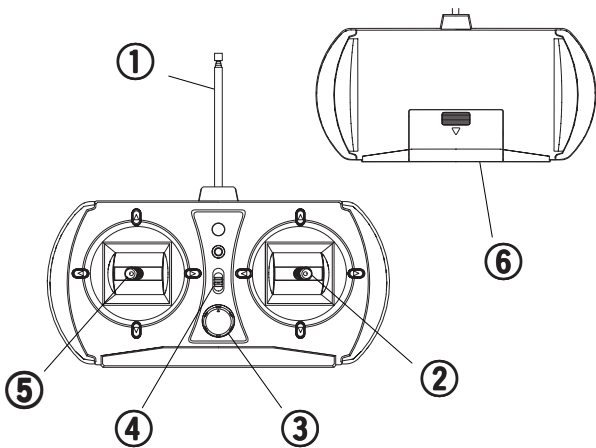

**II 1**

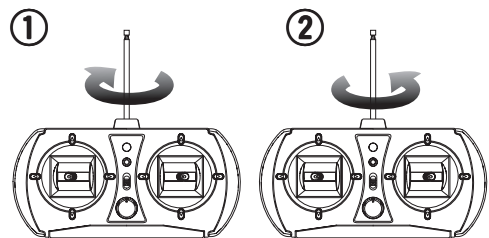

**II**

2

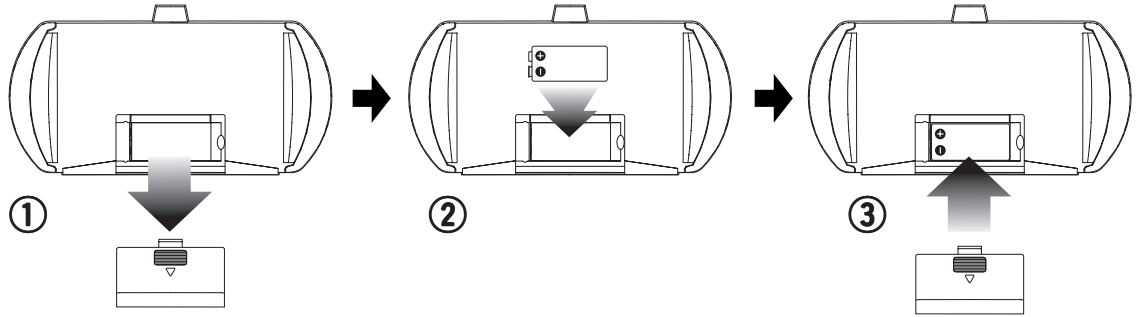

**III**

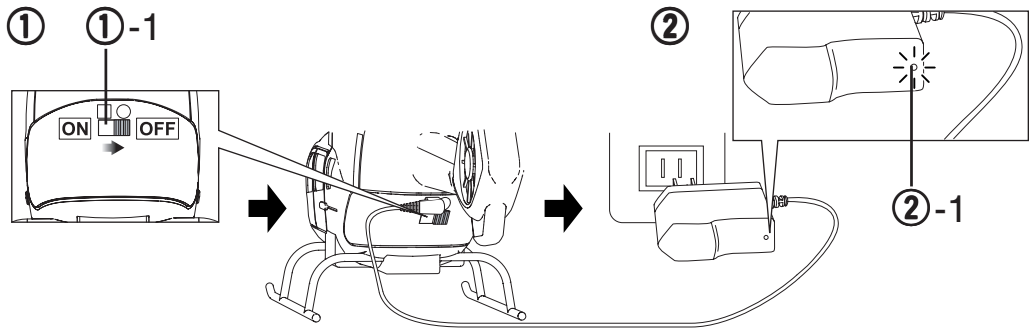

**IV**

1

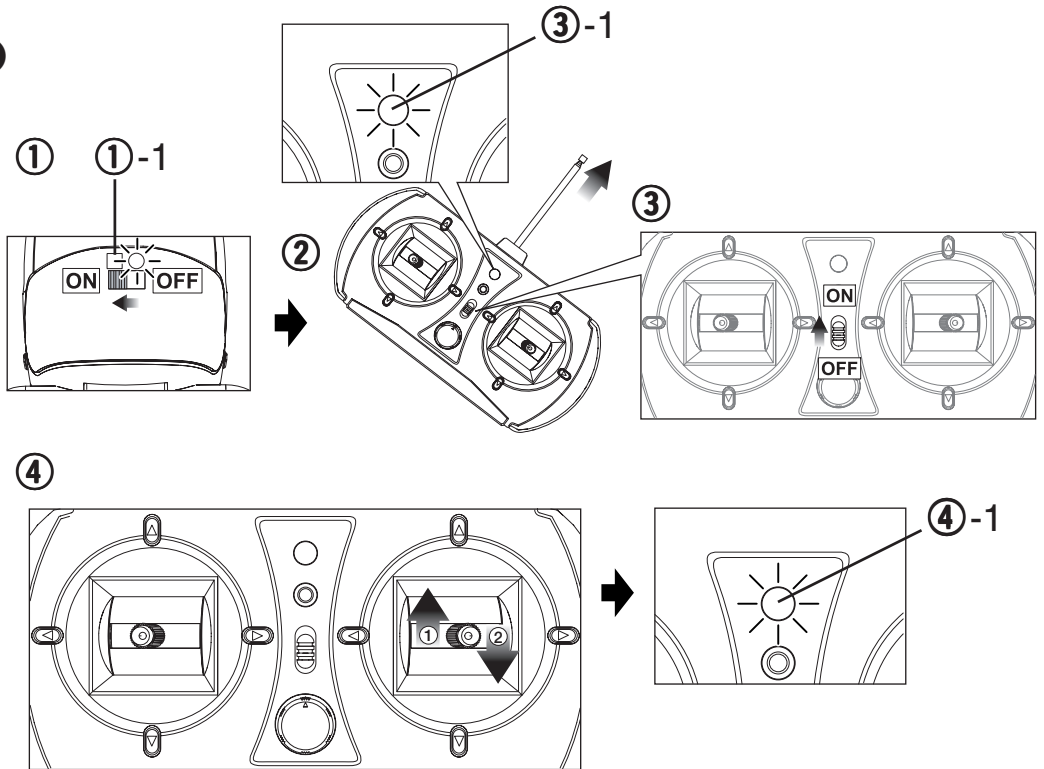

3

**IV**

**2**

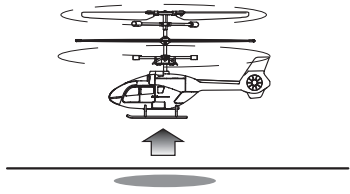

**①-1**

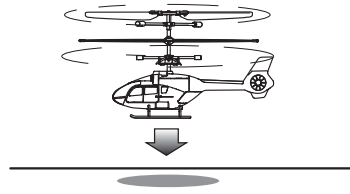
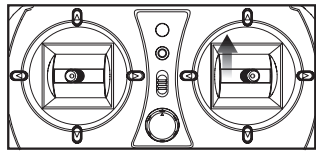

**①-2**

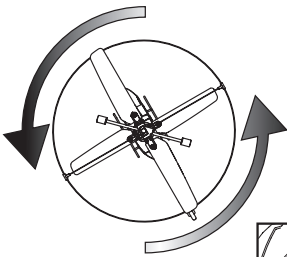
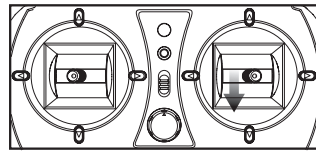

**②-1**

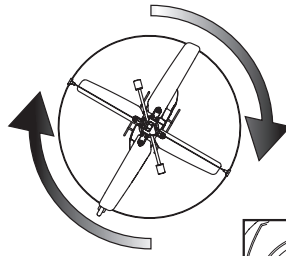
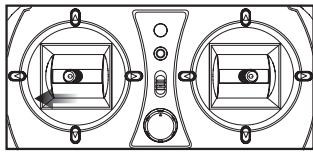

**②-2**

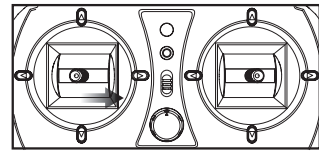

**3**

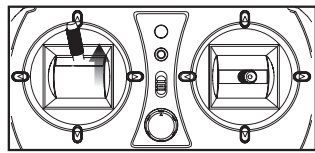
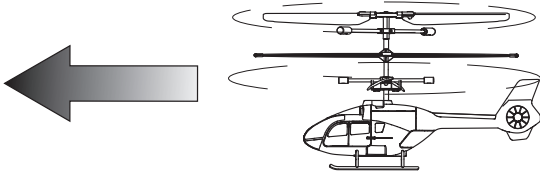

**3**

**①**

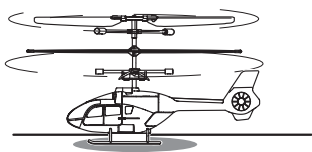

**①-1**

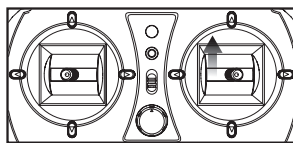

**①-2**

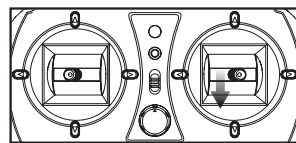

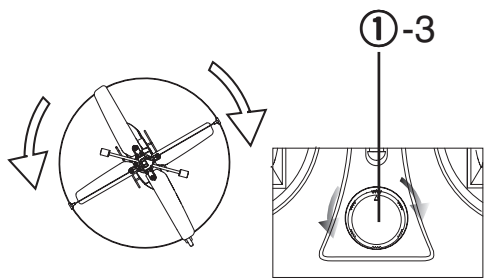

2

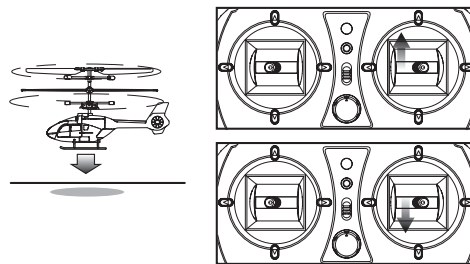

3

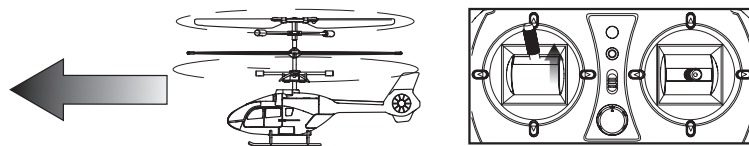

4

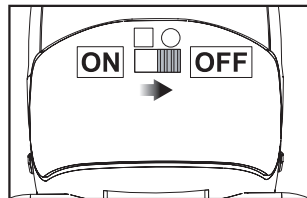

V

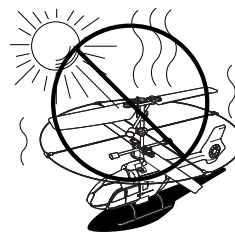
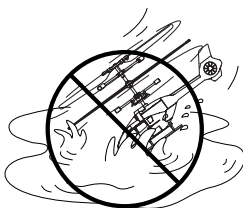
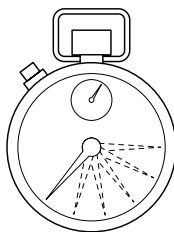
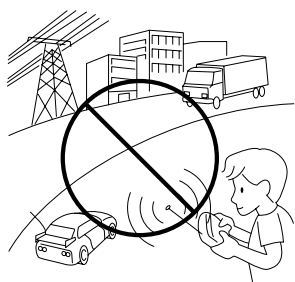
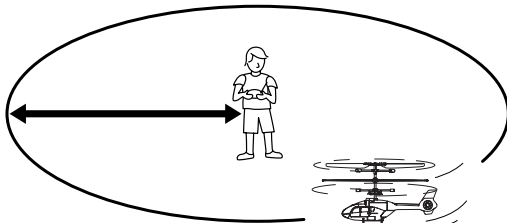

5

## Precaution

### Safety first

#### CAUTION: TO AVOID BATTERY LEAKAGE. (OF BUILT-IN LiPoly RECHARGEABLE BATTERIES)

- Charge batteries following the battery and charger manufacturer's instructions.
- Charge batteries with the included charger at the first use.
- Do not charge batteries with a charger other than the included one.
- Do not charge batteries other than the built-in LiPoly battery with the included charger or use the charger as the power source for other equipment.
- Do not charge batteries in a place within the reach of small children.
- Do not give an impact to batteries and the charger during charging
- Do not re-peak a LiPoly battery that has peaked, otherwise the battery may be degraded. LiPoly batteries have a low natural discharge rate, it does not require recharging in the first one or 2 hours after a charge.
- When charge is complete, unplug the charger from the wall outlet.
- After use, be sure to turn the switch off. Failure to do so may adversely affect batteries, resulting in disabled charge.
- Do not short circuit battery terminals, otherwise the battery may swell and get hot, leading to a danger.
- Do not wet batteries, heat, disassemble or modify them. Do not dispose of batteries in fire.
- Do not use, store or charge batteries in a place near a heater, or in high temperature or humidity condition.
- When the use out of batteries becomes shorter and shorter, it is most likely time to replace the battery. Contact our service representative in such a case.

#### CAUTION: TO AVOID BATTERY LEAKAGE. (OF 9-VOLT (006P) RECHARGEABLE BATTERIES FOR TRANSMITTER)

- Use 006P-9V dry batteries for transmitter.
- Make sure the batteries are inserted with correct polarity and follow the toy and battery manufacturer's instructions.
- After use, remove the batteries from the transmitter to store.
- Battery replacement should be done in presence of adult.
- Do not attempt to short-circuit, disassemble or heat batteries. Do not dispose of batteries in fire or wet them.
- If battery fluid contacts your eyes, skin or cloths, immediately wash them with water and consult a doctor.

### Precautions before Flight

Depending on flight condition or due to improper control, flying a helicopter can be hazardous resulting in unforeseen accidents such as bodily injury and property damage, and the helicopter operator shall be held responsible for such accident. To be a responsible operator, you are recommended to obtain adequate insurance before playing with the helicopter.

### CAUTIONS DURING PLAYING

- For avoiding hazards from improper use, this helicopter is not intended for children under 15 years old. Also, children are recommended to use this helicopter under adult's supervision.
- Do not touch charging terminals (i.e., the metal part) on the helicopter body and the charger.
- Make sure you have plenty of open space in all directions (at least 3m-radius from your location). Fly the helicopter in a safe area away from people, pets, etc.
- Check if a near transmitter produces interference or signals with the same frequency. In such a case, move to another place or try after a while.
- Do not point the transmitter antenna toward a person's or animal's head, otherwise an unforeseen accident may occur. Also, do not bend the antenna.
- Do not throw the helicopter toward a person or animal, otherwise an injury may occur.
- Do not bend or pull the components with a strong force.
- Do not keep looking at the blinking LEDs on the transmitter and the helicopter body. Doing so may cause you to feel uncomfortable.
- Never attempt to disassemble or modify the helicopter.
- Do not bring your face or hands near the rotating rotor. For safety's sake, you are recommended to wear goggles.
- Keep supervision to the helicopter in flight.
- Do not operate the rotor while it is locked.
- Do not drop or impact.
- Do not use an helicopter if it is unrecoverably damaged or distorted.
- After use, store the helicopter in a place out of the reach of children 3 years old or younger.
- Do not store the helicopter in a place near a heater or like where temperature rises (e.g., a shut up car in summer).

### Battery Disposal Instructions

THIS PRODUCT USES A LITHIUM POLYMER BATTERY. MUST BE RECYCLED OR DISPOSED PROPERLY.

Contact your local area office of solid waste management or other appropriate local agency for information. Do not attempt to disassemble the battery before disposal.

Please check the headings I - VI with the diagrams in pages 2, 3, 4, 5.

## I. CONTENTS & FEATURES

**This kit includes:**

- A. Micro Master x 1
- B. Transmitter x 1
- C. Charger x 1
- D. Transmitter antenna x 1
- E. Manual x 1

The product shown in the figure may slightly differ from the real ones.

### 1 Micro Master

- 1 Rotor
  - \* The rotor has a play structure for safety, but not completely fixed. When the rotor starts rotating, the centrifugal force acts on the rotor allowing it to operate normally.
- 2 Tail fin
- 3 Antenna
  - \* Do not cut the antenna rods.
- 4 Charging port / Power switch (at the bottom)
- 5 3.7V LiPoly battery embedded
- 6 Skid
- 7 Body
- 8 Safety ring

### 2 Transmitter Front

- 1 Antenna
- 2 Throttle Stick
- 3 Adjustment Knob
- 4 Switch
- 5 Rudder stick (left/right) / Forward stick (forward)

### Rear

- 6 Battery Cover

## II. Installation

### 1 Transmitter Antenna Installation / Uninstallation

- 1 Antenna Installation
 

Turn the antenna clockwise to screw it in the transmitter body.

The antenna is screw-in type. Securely screw it in place, otherwise a malfunction may result from loose antenna connection.
- 2 Antenna Uninstallation
 

Turn the antenna counterclockwise to remove it. When housing the antenna, retract it from the root rib for avoiding bending of the antenna rod.

### 2 Transmitter Battery Installation

Use one 9-Volt (006P) battery for the transmitter (not included).

- 1 Slide open the BATTERY DOOR in the direction shown in the figure.
- 2 Insert the BATTERY with correct polarity (+/-).
 

Insert a 9V (006P) BATTERY with the polarity (+/-) as shown above.
- 3 Replace battery door, following the removal procedure in reverse.
  - \* When the capacity of the 9V battery becomes low, Power LED lamp changes from steady to blinking. You need to replace the 9V battery, otherwise a malfunction may occur due to shortened operating distance.

## III. Built-in Battery Charging Instructions

A rechargeable battery is built into the helicopter body. Be sure to charge the battery before you use it. The built-in LiPoly battery, if not handled properly, may explode, cause burns or catch fire resulting in a serious accident.

Read "Handling of Lithium Polymer Battery" and handle the battery properly.

- 1 Set the power switch of the helicopter to "OFF", insert the charger connector to the charging port on the helicopter then plug the charger to a standard wall outlet.
 

The LED lamp will light in red.

  - \* The LED lamp lights in green if the charger is plugged to a wall outlet while the charger connector is not inserted to the helicopter.
- 1-1 Charging port.
- 2 Red lamp on charger will light to show charger is operating.
  - 2-1 Charging port.
- 3 When charge is complete, the LED lamp changes to green. Remove the charger connector from the charging port on the helicopter then unplug the charger from the wall outlet.
  - \* Battery charging time varies with battery level. As a guide, it takes approx. 1 hour when the battery is near empty, or 30 minutes if half-empty.

### Important:

- To prevent overcharge of batteries, observe the following instructions: Do not re-peak a LiPoly battery that has peaked. The battery, if not used to fly the helicopter, does not require recharging in the first one or 2 hours after a charge.

## IV. How to Fly

### 1 Preparation for flight

- 1 Turn on the switch on the helicopter body, then the LED lamp starts blinking. When the LED lamp changes to steady, the helicopter becomes ready for flight.
  - 1-1 LED lamp.
- 2 Completely extend the transmitter antenna.
- 3 Turn on the switch on the transmitter. Then, the LED lamp starts blinking.
  - 3-1 LED lamp (blinking)
- 4 Move the throttle stick to the top position then to the bottom. The transmitter gets ready when the LED lamp changes from blinking to steady.
  - 4-1 LED lamp (steadily lighting)
- 5 Stay at least 2m away from the helicopter before flying it up.
- 6 Check safety of environment around you. Now you are ready if no obstacles exist.

### 2 Transmitter Functions

- 1 Throttle stick (right)(UP/DOWN)
 

Moving the throttle stick up allows the helicopter to ascend, and moving the stick back makes the helicopter descend.

  - 1-1 Up
  - 1-2 Down
- 2 Rudder stick (left)(Left / Right)
 

Moving the rudder stick left allows the helicopter to turn left, and moving the stick right makes the helicopter turn right.

  - 2-1 Left turn
  - 2-2 Right turn
- 3 Forward stick (left)(Forward)
 

Moving the forward stick up allows the helicopter to fly forward.

### 3 Get skilled with the helicopter

- 1 Slowly move the throttle stick up, then the rotor starts rotating and the helicopter ascends. Since the ascending power varies in synchronization with the stick operation, adjust the throttle stick (right) to make the helicopter hover when it reaches a height of approx. 2m.
  - 1-1 Up
  - 1-2 Down
  - If the helicopter tends to turn to one side, turn the adjustment knob on the transmitter to correct it.
  - 1-3 Adjustment knob
- 2 To move the helicopter down, move the throttle stick (right) back more slowly =than when moving the helicopter up. When the helicopter starts descending, hold the stick in its position. The helicopter will land gently by itself.
- 3 While the helicopter is hovering, moving the forward stick (left) up allows the

helicopter to fly forward. The helicopter may experience a small descent as it flies forward, slightly move the throttle stick up to correct it.

#### 4 After use

Turn off the switch on the helicopter then turn off the transmitter. Be sure to retract the transmitter antenna.

#### Important:

- This helicopter is equipped with a feature for monitoring the battery level of the built-in battery. The LED lamp blinks if the battery level becomes low.

Turn off the switch when the LED lamp starts blinking. Failure to do so may adversely affect batteries, resulting in disabled charge.

## V. Flight Location and Condition

### Flight Condition

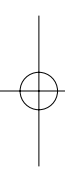

Fly the helicopter in a place where the floor is flat and no obstacle exists. Avoid locations exposed to discharge air (e.g., a location near air conditioning vent), otherwise the helicopter may become uncontrollable. Be sure to fly the helicopter in calm condition.

#### Important:

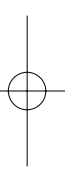
- Keep supervision to the helicopter in flight.
  - Children are recommended to play under adult supervision.
- 

## VI. Maintenance

### Care and Service

- The life of the helicopter can be extended by daily care. Wipe the helicopter clean if dust or the like builds up and check if any loose part.
- The helicopter body is made of polystyrene foam. If damaged, use scotch tape or suitable adhesives to repair.
  - \* Never use instant glue which will make the polystyrene foam dissolve.
- The helicopter may lose balance if broken and cannot fly normally, ask our service representative for repair. (Refer to "After Service" for details".)

### FCC STATEMENT

This device complies with part 15 of the FCC Rules. Operation is subject to the following two conditions:

- (1) This device may not cause harmful interference, and
- (2) this device must accept any interference received, including interference that may cause undesired operation.

Changes or modifications to this unit not expressly approved by the party responsible for compliance could void the user's authority to operate the equipment.



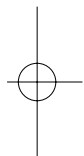
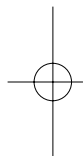
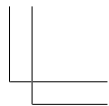
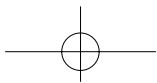
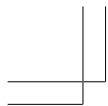

638A508-01

