



Owner's Manual

Model Numbers:

TBC-2211, TBC-2251, TBC-230/B
TRIMMERS/BRUSHCUTTERS

P/N 27960

Date 12-20-02



TBC-2211



TBC-2251

Supplier To The Outdoor Power Equipment Industry

ISM, Inc. • 1028 4th Street SW • Auburn, WA 98001 • Phone: (253) 333-1200 • Fax: (253) 333-1212

Before using this unit:

- Read the operator's manual carefully.
- Check that the cutting equipment is correctly assembled and adjusted.
- Start the unit and check the carburetor adjustment. See "Maintenance".

⚠ WARNING

The engine exhaust from this product contains chemicals known to the State of California to cause cancer, birth defects and other reproductive harm.



Always wear eye, head and ear protectors when using this unit.

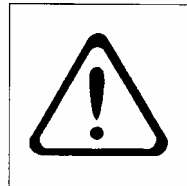

Read, understand and follow all warnings and instructions in this manual and on the unit.

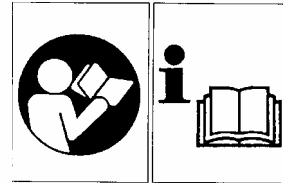

It is important that you read, fully understand and observe the following safety precautions and warnings. Careless or improper use of the unit may cause serious or fatal injury.

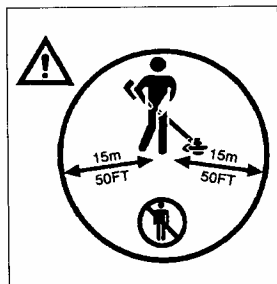

Keep all children, bystanders and helpers 15m (50 ft) away from unit. If anyone approaches you, stop the engine and cutting attachment immediately.

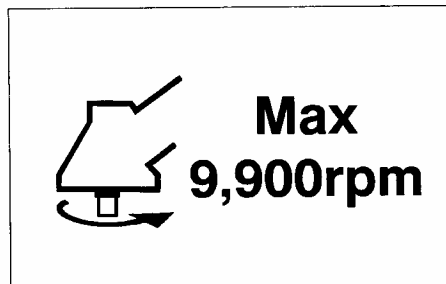

Shows maximum shaft speed. Do not use the cutting attachment whose max rpm rating is below the shaft rpm.

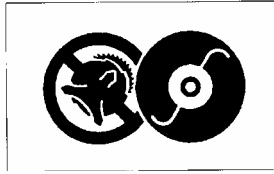

Do not use metal/rigid blades when this sign is shown on the unit.



Be careful of thrown objects.



Gloves should be worn when necessary, e.g. when assembling cutting equipment.



Use anti-slip and sturdy footwear.

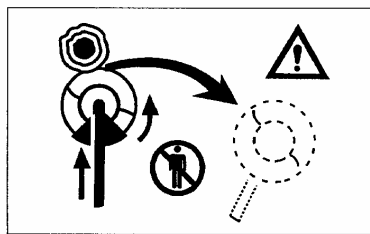

Blade thrust may occur when the spinning blade contacts a solid object in the critical area. A dangerous reaction may occur causing the entire unit and operator to be thrust violently. This reaction is called **BLADE THRUST**. As a result, the operator may lose control of the unit which may cause serious or fatal injury. Blade thrust is more likely to occur in areas where it is difficult to see the material to be cut.

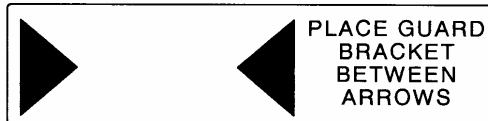

Indicates blade guard location for trimmer head or Brain Head.

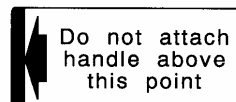

Indicates handle location. Do not attach handle above this point.

⚠ WARNING! • Read the Operator's Manual and follow all warnings and safety instructions. Failure to do so can result in serious injury to the operator and /or bystanders. • Objects may be thrown or ricochet in all directions. **ALWAYS WEAR EYE PROTECTION.** • Keep bystanders at least 50 feet (15m) away. • To reduce the chance of hearing loss, always wear ear protection. • To reduce the risk of injury from loss of control, never use a metal blade on a curved shaft grass trimmer. Never use a metal blade on any brushcutter without barrier bar or bicycle handle configuration and safety strap. • Use of a blade may cause a sudden sideways, forward or backward motion of the brushcutter when the blade contacts a solid object. See Owner's manual for model specific details.

1. What is What?

Since this manual covers several models, there may be some difference between pictures and your unit. Use the instructions that apply to your unit.

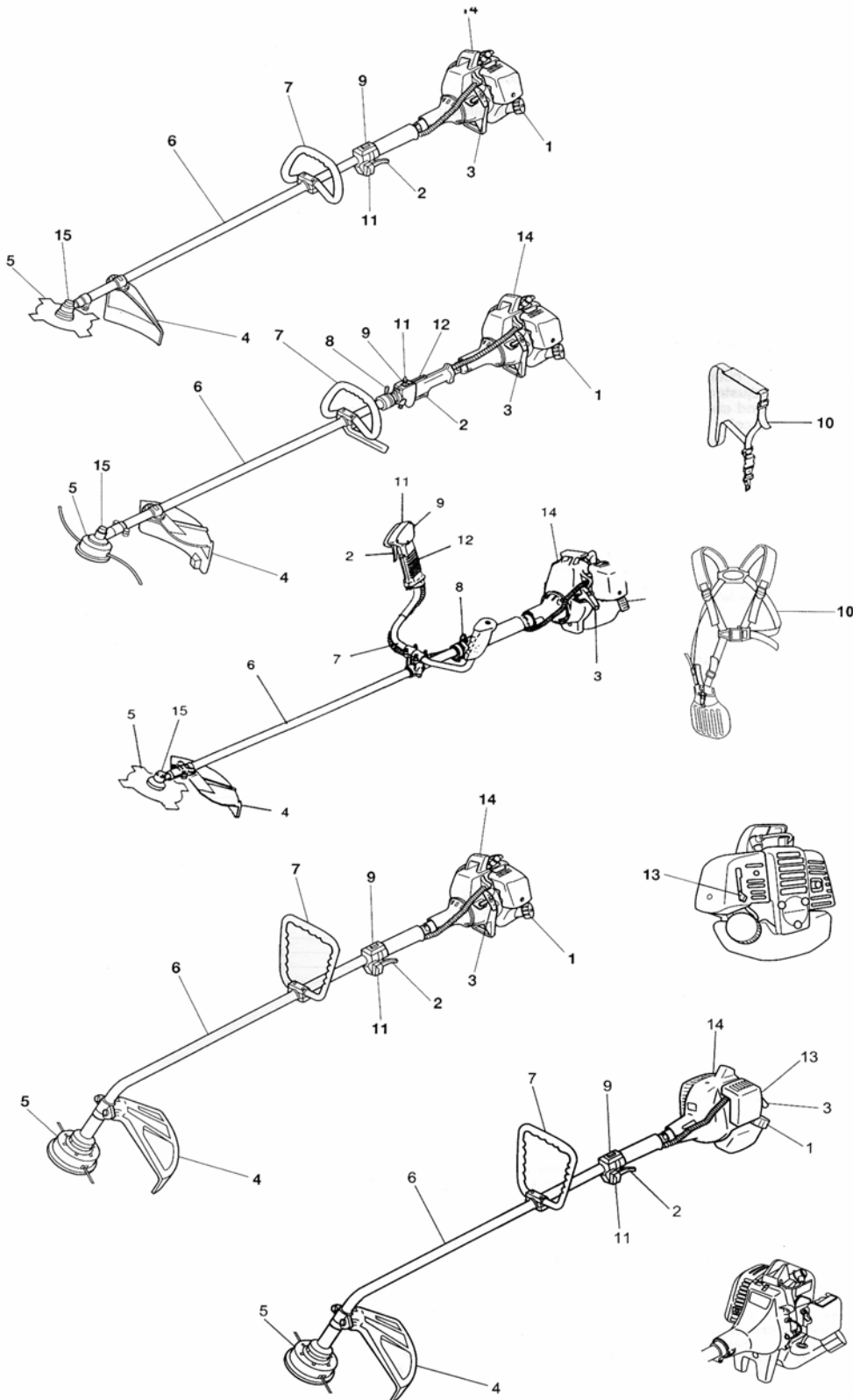

1. Fuel Cap
2. Throttle trigger
3. Starter handle
4. Blade Guard
5. Cutting attachment
6. Drive shaft tube
7. Handle bar
8. Suspension eyelet
9. Ignition switch
10. Harness
11. Throttle lock
12. Safety trigger
13. Choke lever
14. Engine
15. Angle transmission

2. Warnings and safety instructions.

Operator Safety

- Always wear a safety face shield or goggles.
- Always wear heavy, long pants, boots and gloves. Do not wear loose clothing, jewelry, short pants, sandals or go barefoot. Secure hair so it is above shoulder length.
- Do not operate the tool when you are tired, ill or under the influence of alcohol, drugs or medication.
- Never let a child or inexperienced person operate the machine.
- Wear hearing protection.
- Never start or run the engine inside a closed room or building. Breathing exhaust fumes can kill.
- Keep handles free of oil and fuel.
- Keep hands away from cutting equipment.
- Do not grab or hold the unit by the cutting equipment.
- When the unit is turned off, make sure the engine has stopped before the unit is set down.
- When operation is prolonged, take a break from time to time so that you may avoid possible white finger disease, which is caused by vibration.

Tool Safety

- Inspect the entire tool before each use. Replace damaged parts. Check for fuel leaks and make sure all fasteners are in place and securely fastened.
- Replace parts that are cracked, chipped or damaged in any way before using the tool.
- Make sure the safety guard is properly attached.
- Keep others away when making carburetor adjustments.
- Use only accessories as recommended for this tools by the manufacturer.

WARNING!

Never modify the tool in any way. Do not use the tool for any job except that for which it is intended.

Fuel Safety

- **Empty the fuel tank before storing the tool. Especially, in case of over three month storage, it is a must otherwise fuel may corrode causing carburetor damage. It is recommended that the fuel be emptied after each use.**
- Mix and pour fuel outdoors and where there are no sparks or flames.
- Use a container approved for fuel.
- Do not smoke or allow smoking near fuel or the tool or while using the tool.
- Wipe up all fuel spills before starting engine.
- Move at least 3 m (10 ft) away from fueling site before starting engine.
- Stop engine before removing fuel cap.
- Store tool and fuel in area where fuel vapors cannot reach sparks or open flames from water heaters, electric motors or switches, furnaces, etc.

WARNING!

Anti-vibration systems do not guarantee that you will not sustain white finger disease or carpal tunnel syndrome. Therefore, continual and regular users should monitor closely the condition of their hands and fingers. If any of the above symptoms appear, seek medical advice immediately.

Cutting Safety

- Do not cut any material other than grass and brush.
- Inspect the area to be cut before each use. Remove objects which can be thrown or become entangled.
- For respiratory protection, wear an aerosol protection mask when cutting grass after insecticides are used.
- Keep others including children, animals, bystanders and helpers outside the 15 m (50ft) hazard zone. Stop the engine immediately if you are approached.
- Always keep the engine on the right side of your body.
- Hold the tool firmly with both hands.
- Keep firm footing and balance. Do not over-reach.
- Keep all parts of your body away from the muffler and cutting attachment when the engine is running.
- Keep the cutting attachment below waist level.

Maintenance Safety

- Maintain the tool according to recommended procedures.
- Disconnect the spark plug before performing maintenance except for carburetor adjustments.
- Keep others away when making carburetor adjustments.
- Use only genuine replacement parts as recommended by the manufacturer.

Transport and storage

- Carry the tool by hand with the engine stopped and the muffler away from your body.
- Allow the engine to cool, empty the fuel tank, and secure the tool before storing or transporting in a vehicle.
- Empty the fuel tank before storing the tool. It is recommended that the fuel be emptied after each use. If fuel is left in the tank, store so fuel will not leak.
- Store tool out of the reach of children.
- Clean the unit carefully and store it in a dry place.
- Make sure engine switch is off when transporting or storing.
- When transporting in a vehicle, cover blade with blade cover.

If situations occur which are not covered in this manual, take care and use good judgment. Contact your dealer if you need assistance.

Pay special attention to statements preceded by the following words:

WARNING!

Indicates a strong possibility of severe personal injury or loss of life, if instructions are not followed.

CAUTION!

Indicates a possibility of personal injury or equipment damage, if instructions are not followed.

NOTE!

Helpful information for correct function and use.

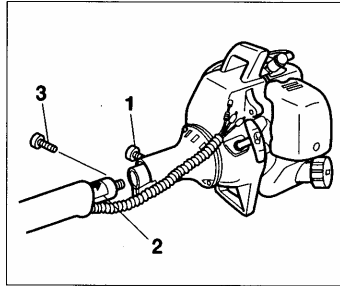

Fig. 1-1

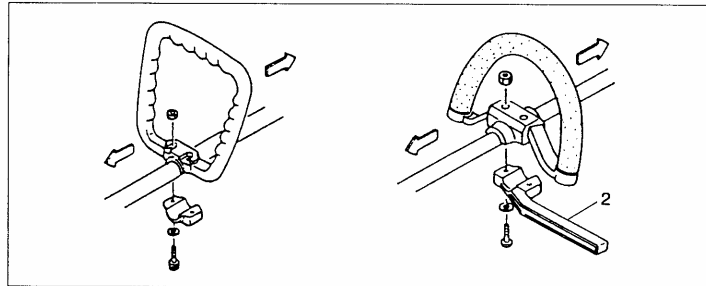

Fig. 1-2

3. Assembly procedures

Drive shaft to engine (Fig. 1 -1)

Loosen tube locking bolt (1) about ten turns so that the bolt tip will not obstruct drive shaft tube to be inserted. When inserting drive shaft tube, hold the tube locking bolt outward preventing inside fitting from obstructing as well.

Insert the drive shaft into the clutch case of the engine until the decal (2) on the drive shaft tube meets the clutch case.

NOTE!

If the pipe will not go in far enough this is because the shaft end is not lined up with the receiver. In this case, turn the drive shaft (at the opposite end of the pipe) while pushing the pipe toward the engine. Tighten the tube-locking (1) bolt by lining up the hole in the shaft tube. Then tighten clamp bolt securely (3).

Installation of handle

WARNING!

When you use steel/rigid blades on straight shaft trimmers or brush cutters, always use barrier bar (2) and shoulder harness with the loop handle. (Fig. 1 -2)

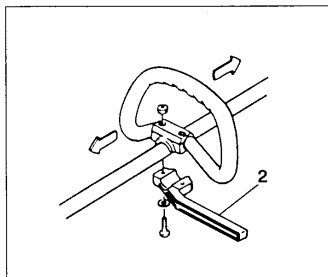

Fig. 1-2B

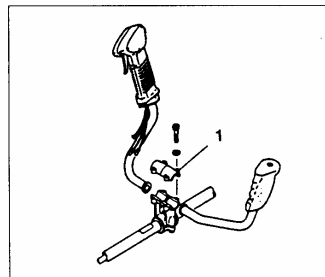

Fig. 1-3

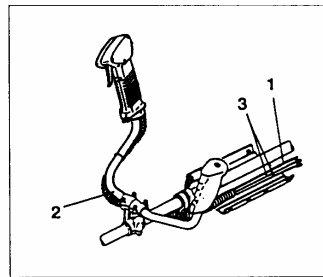

Fig. 1-3B

Attach the handle to the drive shaft tube with the angle towards the engine.

Adjust the location to the most comfortable position before operation.

Remove the handle bracket (1) from the assembly. (Fig. 1 -3)

Place the handles and attach the handle bracket with four bolts lightly. Adjust to appropriate position. Then fix it firmly with the bolts.

Put stop cords (3) and throttle wire (1) through protective tube (2), then unhook the hip pad. (Fig. 1-3B)

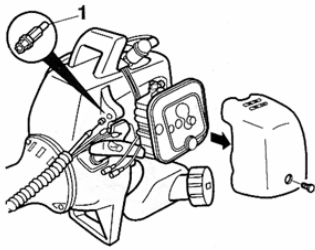

Fig. 1-4

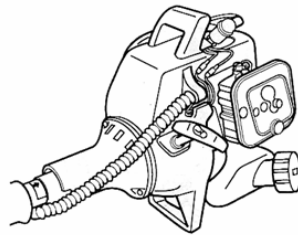

Fig. 1-5

Throttle wire/stop cord

Remove the air cleaner cover. (Fig. 1-4)

Connect stop cords. (Fig. 1 -5)

Set outer receiver (1) (if so provided) into wire guide and put throttle wire through the outer receiver. (Fig. 1 -4)

Connect throttle wire end to carburetor. (Fig. 1 -6)

Cover throttle wire and stop cords together with protective tube provided up to air cleaner cover. (Fig. 1 -7)

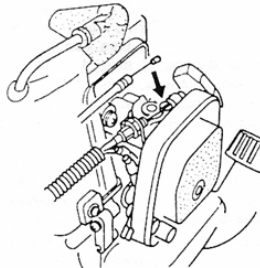
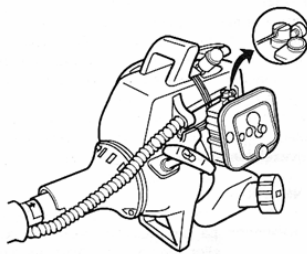

Fig. 1-7

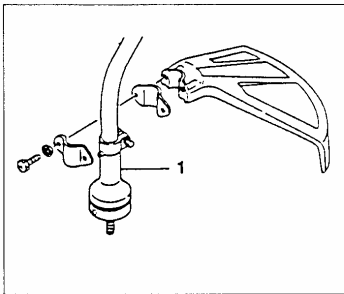

Fig. 1-8

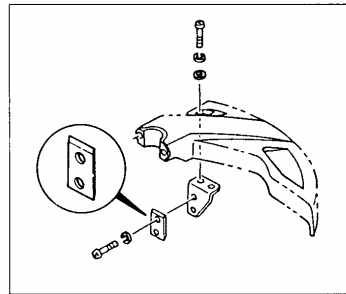

Fig. 1-8B

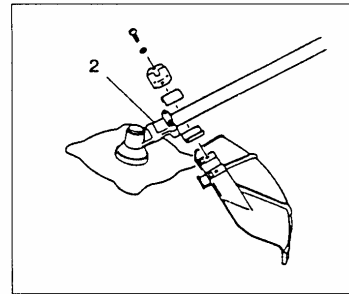

Fig. 1-8C

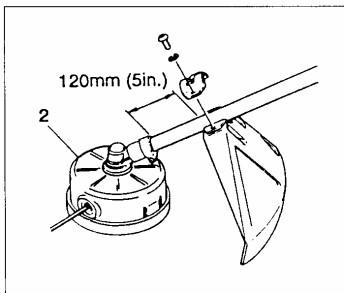

Fig. 1-8D

Installation of blade guard (Fig. 1-8, 8B, 8C)

Install the blade guard on the drive shaft tube against angle transmission (2) / gear case (1). Tighten the guard bracket firmly so that the blade guard does not swing or move down during operation.

When using a trimmer head (2), locate the guard above the angle transmission. (Fig. 1-8D, 9B)

CAUTION!

Do not attempt to install metal blade on the curved shaft trimmer. It is very dangerous.

CAUTION!

Some blade guards are equipped with sharp line limiters. Be careful with handling it.

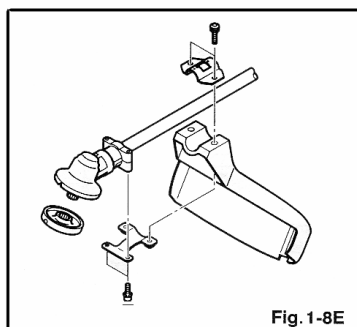

Fig. 1-8E

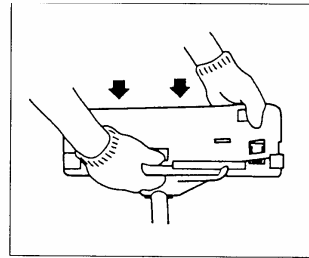

Fig. 1-9

When using a trimmer head (2) with a two piece type blade guard, attach the guard extension to the blade guard. (Fig. 1-9) Then locate the guard above the gear case. (Fig. 1-8B)

NOTE!

If your unit has guard location label on the drive shaft tube, follow the indication.

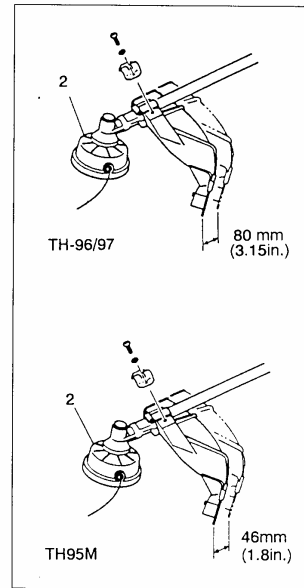

Fig. 1-9B

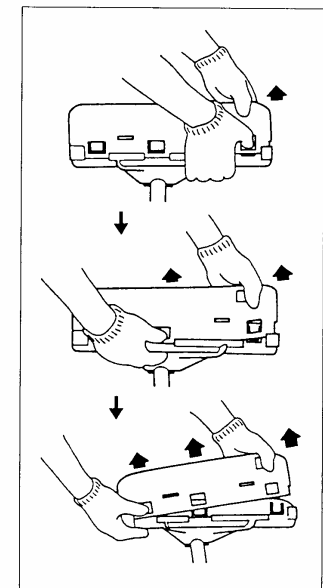

Fig. 1-9C

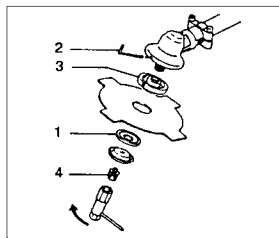

Fig. 1-10

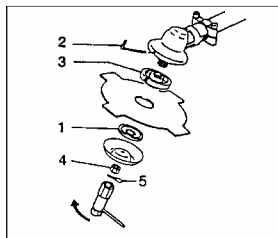

Fig. 1-10B

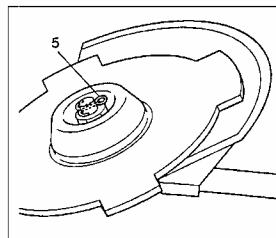

Fig. 1-10C

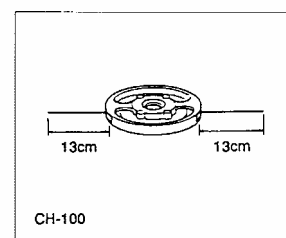

Fig. 1-11

Installation of cutting blades (Fig. 1-10, 10B) (If so equipped) When installing a cutting blade, make sure there are no cracks or damage and that the cutting edges are facing the correct direction.

NOTE!

When installing the cutter holder cap (1), be sure to set the concave side toward the blade.

Insert the allen wrench (2) into the hole of the gear case in order to lock the cutter holder (3). Please note that the cutter fixing bolt or nut (4) has left handed threads, (clockwise to loosen/counter-clockwise to tighten). Tighten the fixing bolt or nut with the box wrench.

NOTE!

If your unit is of a nut-securing type, the blade must be retained with a new cotter pin (5) each time installed. (Fig. 1 -10C)

CAUTION!

Before operation, make sure the blade has been properly installed.

CAUTION!

If your unit is equipped with protection cover under a cutting blade, check it for weariness or cracks before operation. If any damage or weariness is found, replace it, as it is an article of consumption.

Installation of the cutting head

NOTE!

For installation see your Cutting Head Owner's Manual, provided with the unit.

WARNING!

For TANAKA heads, use only flexible, non-metallic line recommended by the manufacturer. Never use wire or wire-ropes. They can break off and become a dangerous projectile.

NOTE!

When using TANAKA alloy head (CH-100), initial cutting line length should be about 13cm (5") each. (Fig. 1 -11)

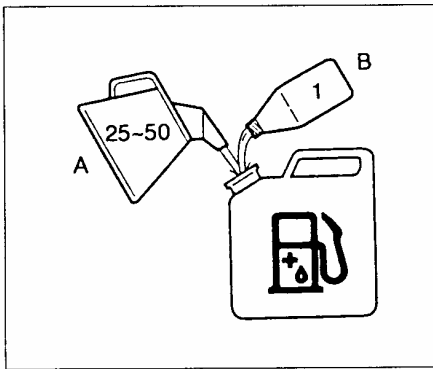

Fig. 2-1

4. Operating procedures

Fuel (Fig. 2-1)

⚠ WARNING!

The trimmer is equipped with a two-stroke engine. Always run the engine on fuel, which is mixed with oil.

Provide good ventilation, when fueling or handling fuel.

Fuel

- Always use branded 89 octane unleaded gasoline.
- Use Tanaka two-cycle oil or a quality two-cycle oil at mixing ratio of 25-50:1 (Gasoline (A) : Oil (B)), only for the state of California at 50:1.
- Never use multi-grade oil (10W/30) or waste oil.
- Always mix fuel and oil in a separate clean container.

Always start by filling half the amount of fuel, which is to be used. Then add the whole amount of oil. Mix (shake) the fuel mixture.

Add the remaining amount of fuel.

Mix (shake) the fuel-mix thoroughly before filling the fuel tank.

Fueling

⚠ WARNING!

- Always shut off the engine before refueling.
- Slowly open the fuel tank, when filling up with fuel, so that possible over-pressure disappears.
- Tighten the fuel cap carefully, after fueling.
- Always move the trimmer at least 3 m (10 ft.) from the fueling area before starting.

Before fueling, clean the tank cap area carefully, to ensure that no dirt falls into the tank.

Make sure that the fuel is well mixed by shaking the container, before fueling.

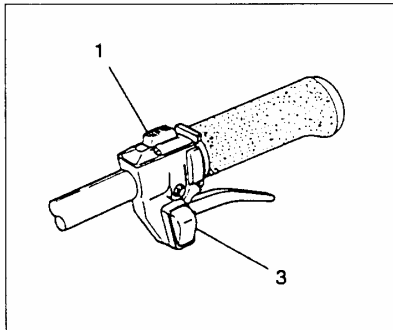

Fig. 2-2

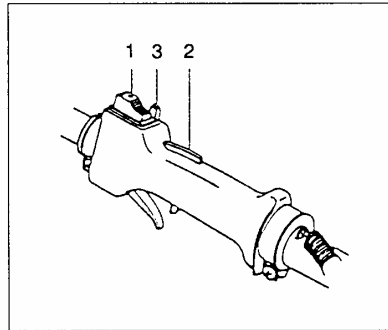

Fig. 2-2B

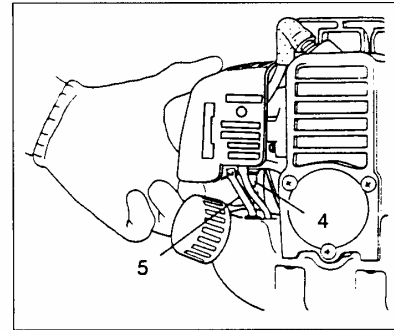

Fig. 2-2C

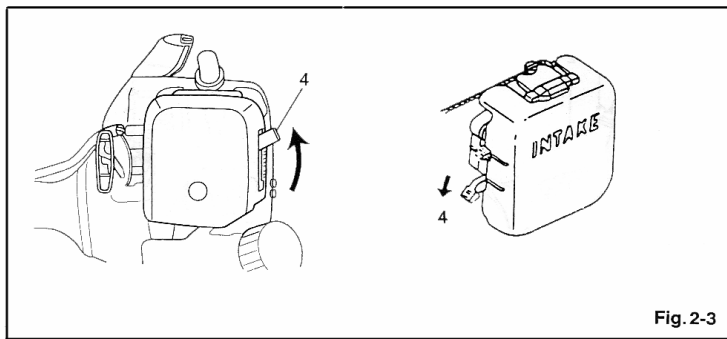

Fig. 2-3

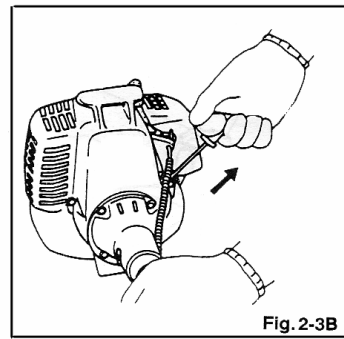

Fig. 2-3B

Starting (Fig. 2-2, 2B)

CAUTION!

Before starting, make sure the cutting attachment is not touching anything.

1. Set ignition switch (1) to the ON position. (Fig. 2-2)
 - *Push priming bulb (4) several times so that fuel flows through return pipe (5) (if so equipped)(Fig. 2-2C)
2. With the safety trigger (2) pressed (if so equipped), pull throttle trigger and push throttle lock (3), then slowly release the throttle trigger first, then the safety trigger. This will lock the throttle in starting position.
3. Set choke lever to CLOSED position (4). (Fig. 2-3)
4. Pull recoil starter briskly, taking care to keep the handle in your grasp and not allowing it to snap back. (Fig. 2-3B)
5. When you hear the engine want to start, return choke lever to RUN position (open). Then pull recoil starter briskly again.

NOTE!

If engine does not start, repeat procedures from 2 to 5.

6. After starting engine, pull throttle trigger to release throttle lock. Then allow the engine about 2-3 minutes to warm up before subjecting it to any load.



Fig. 2-4

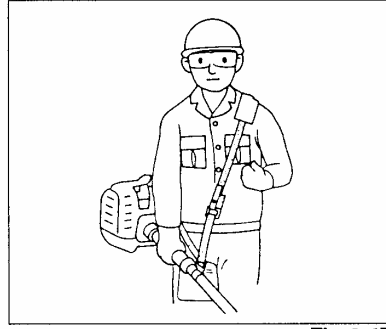

Fig. 2-4B

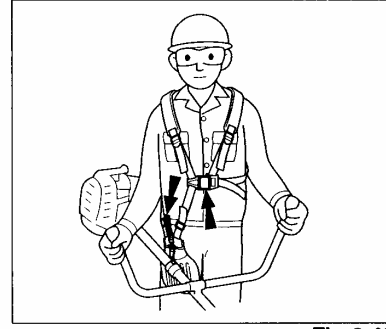

Fig. 2-4C

Cutting (Fig. 2-4, 4B, 4C, 4D)

- When cutting, operate engine at over 6500 rpm. Extended use at a slow speeds may wear the clutch prematurely.
- Cut grass from right to left.
- Blade thrust may occur when the spinning blade contacts a solid object in the critical area. A dangerous reaction may occur causing the entire unit and operator to be thrust violently. This reaction is called BLADE THRUST. As a result, the operator may lose control of the unit which may cause serious or fatal injury. Blade thrust is more likely to occur in areas where it is difficult to see the material to be cut.
- Wear the harness as shown in the figure (if so equipped). The blade turns counterclockwise, therefore, be advised to operate the unit from right to left for efficient cutting. Keep onlookers out of working area at least 15 m (50 ft.).

NOTE!

Press the quick release button or pull emergency release flap (If so equipped) in the event of emergency. (Fig. 2-4C)

⚠ WARNING!

If the cutting attachment should strike against stones or other debris, stop the engine and make sure the attachment and related parts are undamaged. When grass or vines wrap around attachment, stop engine and attachment and remove them.

Stopping (Fig. 2-5)

- Decrease engine speed and run at an idle for a few minutes, then turn off ignition switch.

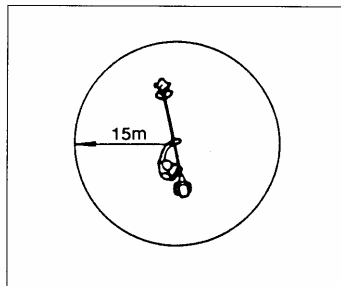

Fig. 2-4D

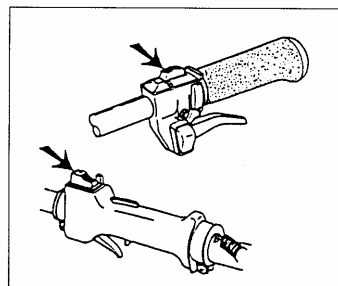

Fig. 2-5

⚠ WARNING!

A cutting attachment can injure while it continues to spin after the engine is stopped or power control is released. When the unit is turned off, make sure the cutting attachment has stopped before the unit is set down.

5. Maintenance

MAINTENANCE, REPLACEMENT, OR REPAIR OF THE EMISSION CONTROL DEVICES AND SYSTEMS MAY BE PERFORMED BY ANY NONROAD ENGINE REPAIR ESTABLISHMENT OR INDIVIDUAL.

Carburetor adjustment (Fig. 3-1)

! WARNING!

The cutting attachment may be spinning during carburetor adjustments.

! WARNING!

Never start the engine without the complete clutch cover and tube assembled! Otherwise the clutch can come loose and cause personal injuries.

In the carburetor, fuel is mixed with air. When the engine is test run at the factory, the carburetor is basically adjusted. A further adjustment may be required, according to climate and altitude. The carburetor has one adjustment possibility:

T = Idle speed adjustment screw.

Idle speed adjustment (T)

Check that the air filter is clean. When the idle speed is correct, the cutting attachment will not rotate. If adjustment is required, close (clockwise) the T-screw, with the engine running, until the cutting attachment starts to rotate.

Open (counter-clockwise) the screw until the cutting attachment stops. You have reached the correct idle speed when the engine runs smoothly in all positions well below the rpm when the cutting attachment starts to rotate.

If the cutting attachment still rotates after idle speed adjustment, contact your service workshop.

NOTE!

Standard Idle rpm is 2500-3000 rpm.

! WARNING!

When the engine is idling the cutting attachment must under no circumstances rotate.

Air filter (Fig. 3-2)

The air filter must be cleaned from dust and dirt in order to avoid:

- Carburetor malfunctions.
- Starting problems.
- Engine power reduction.
- Unnecessary wear on the engine parts.
- Abnormal fuel consumption.

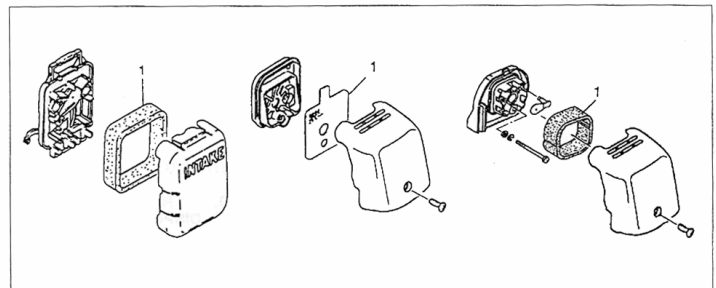

Fig. 3-2

Clean the air filter daily or more often if working in exceptionally dusty areas.

Cleaning the air filter

Remove the air filter cover and the filter (1).

Rinse it in warm soap suds. Check that the filter is dry before reassembly. An air filter that has been used for some time cannot be cleaned completely. Therefore, it must regularly be replaced with a new one. A damaged filter must always be replaced.

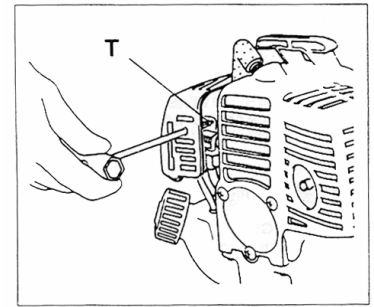

Fig. 3-1

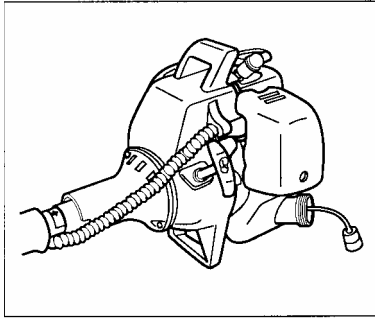

Fig. 3-2B

Fuel Filter (Fig. 3-2B)

Drain all fuel from fuel tank and pull fuel filter line from tank. Pull filter element out of holder assembly and rinse element in warm water with detergent.

Rinse thoroughly until all traces of detergent are eliminated. Squeeze, do not wring, away excess water and allow element to air dry.

NOTE!

If element is hard due to excessive dirt buildup, replace it.

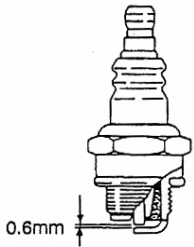

Fig. 3-3

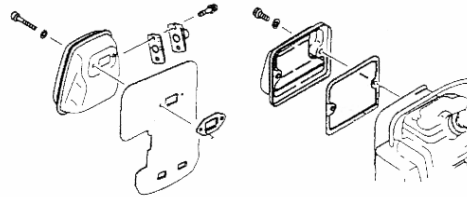

Fig. 3-4

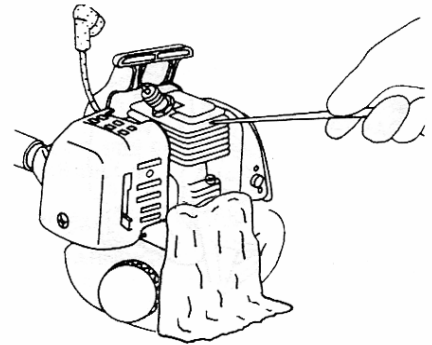

Fig. 3-4B

Spark plug (Fig. 3-3)

The spark plug condition is influenced by:

- An incorrect carburetor setting.
- Wrong fuel mixture (too much oil in the gasoline)
- A dirty air filter.
- Hard running conditions (such as cold weather).

These factors cause deposits on the spark plug electrodes, which may result in malfunction and starting difficulties. If the engine is low on power, difficult to start or runs poorly at idling speed, always check the spark plug first. If the spark plug is dirty, clean it and check the electrode gap. Readjust if necessary. The correct gap is 0.6 mm. The spark plug should be replaced after about 100 operation hours or earlier if the electrodes are badly eroded.

NOTE!

In some areas, local law requires using a resistor spark plug to suppress ignition signals. If this machine was originally equipped with resistor spark plug, use same type of spark plug for replacement.

Muffler (Fig. 3-4)

Remove the muffler and remove excess carbon from the exhaust port or muffler inlet every 100 hours of operation.

Cylinder (Engine cooling) (Fig. 3-4B)

The engine is air cooled, and air must circulate freely around engine and over cooling fins on cylinder head to prevent overheating.

Every 100 Operating hours, or once a year (more often if conditions require), clean fins and external surfaces of engine of dust, dirt and oil deposits which can contribute to improper cooling.

NOTE!

Do not operate engine with engine shroud or muffler guard removed as this will cause overheating and engine damage.

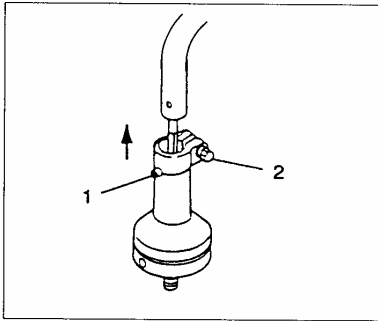

Fig. 3-5

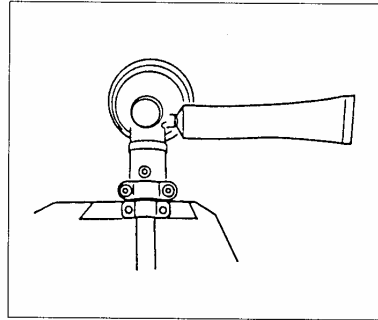

Fig. 3-5B

Flexible drive shaft (Fig. 3-5)

Flexible drive shaft should be removed and lubricated with a good quality lithium grease every 20 hours. To remove the flexible shaft, first remove screw (1), loosen bolt (2) and remove the gear case then pull the shaft out of the drive shaft pipe. Clean the shaft off and apply a generous coat of lithium grease to it and insert it back into the drive shaft pipe, turn it until it drops into place then install the gear case, and install & tighten screw (1) and screw (2).

Angle transmission (Fig. 3-5B)

Check the gear case for grease level about every 50 hours of operation by removing the grease filler plug on the side of case.

If no grease can be seen on the flanks of the gears, fill the transmission with a quality lithium based multipurpose grease up to $\frac{3}{4}$ full.

Do not completely fill the transmission.

Blade (Fig. 3-6)

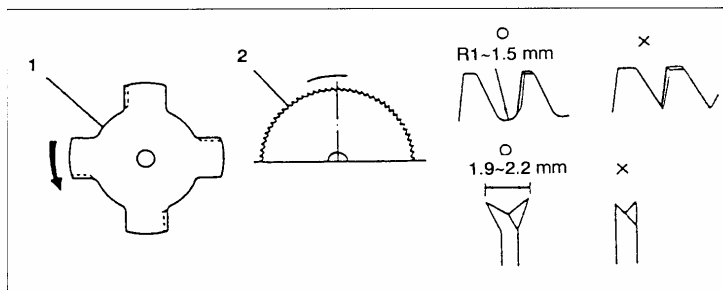

Fig. 3-6

⚠ WARNING!

Wear protective gloves when handling or performing maintenance on the blade.

- Use a sharp blade. A dull blade is more likely to snag and thrust. Replace the fastening nut if it is damaged and hard to tighten.
- When replacing blade, purchase one recommended by TANAKA, with a 25.4mm (one inch) mounting hole.
- When installing a saw blade (2), always face the stamped side up. In the case of a 4 tooth blade (1), it can be used on either side. Use correct blade for the type of work.
- When replacing a blade, use appropriate tools.
- When cutting edges become dull, re-sharpen or file as shown in figure. Incorrect sharpening may cause excessive vibration.
- Discard blades that are bent, warped, cracked, broken or damaged in any way.

NOTE!

When sharpening blade it is important to maintain an original shape of radius at the base of the tooth to avoid cracking.

Maintenance schedule

Below you will find some general maintenance instructions.

For further information please contact your Tanaka service dealer.

Daily maintenance

- Clean the exterior of the unit.
- Check that the harness is undamaged.
- Check the blade guard for damage or cracks. Change the guard in case of impacts or cracks.
- Make sure the cutting attachment is properly centered, sharp, and without cracks. An off-centered cutting attachment induces heavy vibrations that may damage the unit.
- Make sure the cutting attachment nut is sufficiently tightened.
- Make sure that the blade transport guard is undamaged and that it can be securely fitted.
- Make sure fasteners are tightened.

Weekly maintenance

- Check the recoil starter, especially cord and return spring.
- Clean the exterior of the spark plug.
- Remove it and check the electrode gap. Adjust it to 0.6 mm, or change the spark plug.
- Clean the cooling fins on the cylinder and check that the air intake at the starter is not clogged.
- Make sure the gear case is filled with grease up to $\frac{3}{4}$ full.
- Clean the air filter.

Monthly maintenance

- Rinse the fuel tank with gasoline.
- Clean the exterior of the carburetor and the space around it.
- Clean the fan and the space around it.

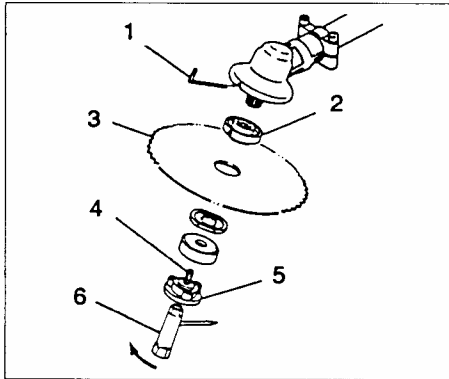

Fig. 4-1

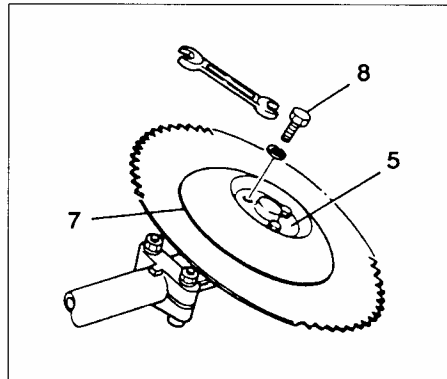

Fig. 4-1B

6. Optional

Installation of free disk set (optional) (Fig. 4-1, 1 B)







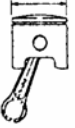

- 1) Disassemble free disk (7) from the free disk set by loosening three bolts (8).
- 2) Place blade (3) as shown in drawing. Disk fixing bolt (4) is left-hand threaded ' Use special care to fix blade firmly. Use alien wrench (1) to hold cutter holder (2) so that you may easily tighten up disk fixing bolt (4) with wrench (6).
- 3) Make sure cutting blade is fixed securely, attach free disk (7) to disk fixing metal (5) with three bolts (8).

Spark arrestor

If your unit comes with a spark arrestor screen and your local regulation requires use of spark arrestor screens for fire prevention, please attach it to the muffler by removing muffler protector and other related parts.

(The spark arrestor meets the regulation of SAE J335-SEP90 and CSA CAN3-Z62. 1 -M77)

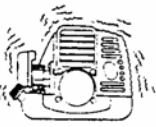
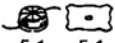
7. Specifications

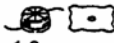
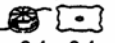
En MODEL	TBC-2211	TBC-2251	TBC-230B TBC-230
			
Engine Size (ml)	21 (1.28 cu. in.)	←	21 (1.28 cu. in.)
			
Spark Plug	Champion CJ8Y or RCJ8Y	←	Champion CJ8Y or RCJ8Y
			
Fuel Tank Capacity (l)	0.33 (11.15 fl.oz)	←	0.43 (14.6 fl.oz)
			
Dry Weight (kg)	4.4 (9.7 lbs)	4.1 (9.0 lbs)	4.1 (9.0 lbs) / 4.6 (10.2 lbs)
			
Sound pressure level (dB(A))	Lpmeasured 95.5	95.2	95.0/89.0
			
Sound power level (dB(A))	Lwguaranteed 112	112	112
			
Vibration level (m/s ²)			 230B  230
Idling (Front handle)	5.1 5.1	5.2	1.3 2.4 2.4
Idling (Rear handle)	3.2 3.0	5.6	2.4 1.5 1.5
Racing (Front handle)	8.0 9.2	2.9	3.8 3.4 6.6
Racing (Rear handle)	9.9 8.0	6.6	2.6 3.8 9.9
Idling (Left handle)	1.3		1.5 1.8
Idling (Right handle)	3.6		1.5 1.5
Racing (Left handle)	2.3		1.4 4.7
Racing (Right handle)	2.7		1.2 4.9

NOTE: Sound levels are calculated as the time-weighted energy total under various working conditions with the following time distribution: ½ idling, ½ racing. All data subject to change without notice.

Declaration of conformity
D6claration de conformit6
Dichiarazione di conformita
Konformitiitserkliirung
Declaraci6n de conformidad
Konformitetsdeklaration

We, Tanaka Kogyo Co., Ltd., 3-4-29 Tsudanuma, Narashino, Chiba, Japan
 Nous, soussign6s,
 Noi,
 Der unterzeichnete,
 Nosotros,
 Vi,

TBC-2211/221ID/2251
 TBC-230/B/D/S

Declare under our sole responsibility that the product, grass trimmer model
 D6clarons sous notre seule responsabilit6 que le produit en question, tondeuse de gazon mod~le
 Dichiariamo sotto la nostra unica responsabilita che il prodotto, il bordatore modello
 Erklart unter, eigener Verantwortung, daB das Produkt, rasenmaher modell
 Declaramos dajo nuestra 6nica responsabilidad que el producto, corta-céspedes modelo
 F6rklarar harmed pd eget ansvar att denna produkt, grasklippare modell

to which this declaration relates is in conformity with the essential safety requirements of directives.

laquelle se rapporte la pr6sente ddclaration est conforme aux directives concernant les conditions de s6curit6 essentielles.

al quale questa dichiarazione si riferisce, ~ conforme ai requisiti di sicurezza essenziali delle direttive.

f6r das these Erklar-ung gilt, den wesentlichen Sicherheitsanforderungen der Directive entspricht.

que corresponde a esta declaraci6n, satisface la (s) siguiente (s) exigencia (s) de seguridad esencial (es) de las directivas.

till vilken denna deklaration tillh6r, uppfyller samtliga vasentliga sakerhetskrav f6reskrivna i ber6rda direktiv.

89/392/EEC, 91/368/EEC, 93/44/EEC, 93/68/EEC, EMC89/336/EEC, 2000/14/EC

The following standards have been taken into consideration

ISO 7112/7113/7916/7917/7918/8380/11682
 (EN-292-2, EN ISO 11806)

Les normes suivantes ont 6t6 prises en consid6ration. Sono stati presi in considerazione i seguenti standard. Die nachfolgenden Standards wurden in Betracht gezogen. Se han tenido en consideraci6n las siguientes normas. Vi har tagit hansyn till f6ljande standards.

Manufactured at: Chiba, Japan

Serial No. up from v001001

Fait A:

No. de s6ric A partir de

Luogo:

Num. di serie da

Erstellt in:

Serien-Nr. ab

Fabricado en:

No. de Serie de

Tillverkad av:

Serienr fr.o.m.

en adelante

Signature:

Signature:

Firma:

Unterschrift:

Fimado:

Signatur:

Seiji Tanaka

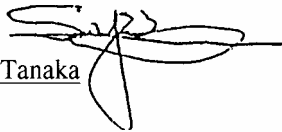

Position: Vice president

Function: Vice-pr6sident

Incarico: Vicepresidente

Titel: Stellvertretender Vorsitzender

Cargo: Vicepresidente

Befatning: Vice President

IMPORTANT NOTICE

THIS INFORMATION IS FOR THE US AND CANADIAN MARKETS ONLY.

- To reduce the risk of injury from loss of control, never use a metal blade on a curved shaft grass trimmer.
- Never use a metal blade on any brushcutter without barrier bar or bicycle handle configuration and safety strap and approve guard.
- Use only attachments or accessories designed for your unit. Although some unauthorized parts may be adaptable, their use may be extremely dangerous and could cause serious injury or death.

Tanaka offers a complete line of trimmer/brushcutter accessories to accomplish any job while ensuring safe operation.

The following Tanaka models are sold as grass trimmers capable of being converted to blade-capable brushcutters: AST-210, TBC-2211, TBC-230, TBC-2510, TBC-3010, TBC-270PF and TBC-270PN.

Blade adapter kit, part # 748501, will convert these models to a blade-capable configuration, and can be purchased at your local Tanaka dealer. The kit contains a safety barrier bar, shoulder strap as well as the necessary blade mounting hardware.

Important Note!

Some of these models were supplied with a safety guard not suitable for blade use and will require the use of blade guard kit # 30060. Guards not permissible for blade use have the following symbol on the guard itself:



WARNING!

The blade conversion kit **MUST** be used when operating these models with blades and do not install without the use of the blade-securing cotter pin (included in the conversion kit). Proper installation of all blade-mounting hardware is required when converting a grass trimmer to a blade-capable brush cutter. Consult your Tanaka dealer if you are uncertain about any aspect of blade use on your Tanaka unit.

Bicycle Style Handle Kit #748502

This kit converts models TBC-2510, TBC-250PF, TBC-270PF/PN and TBC-3010 from D style handle to dual handled style brushcutters.

Cutting Attachments for Tanaka Trimmers and Brushcutters

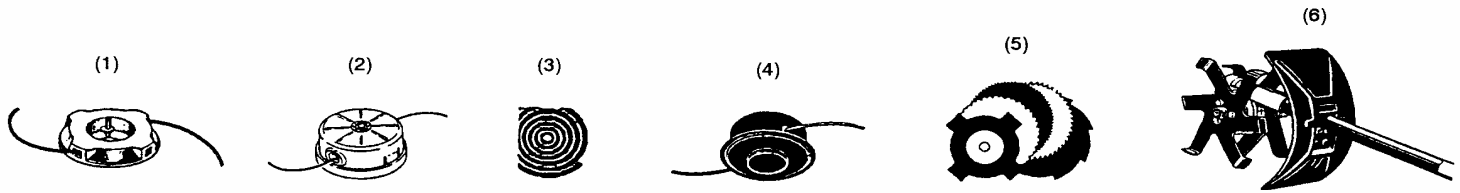

- 1) Fixed line commercial cutting heads offer excellent durability and light weight. Great for commercial use.
- 2) Tanaka Brain fully automatic heads. The Brain senses when more line is needed and utilizes centrifugal force to always feed the perfect length of line.
- 3) Copolymer nylon cutting line. Easy to load into any trimmer head. Resilient, flexible and melt resistant.
- 4) Bump feed semi-automatic heads. For use on curved and straight shaft trimmers. Simple construction provides for dependable performance.
- 5) Cutting blades. Various sizes and configuration of steel brushcutter blades to accommodate any brush cutting application.
- 6) Cultivator attachment. Ideal for quick garden/ flower bed weeding and cultivation. Simple and easy installation.

****Contact your local Tanaka dealer for application information.**