

Digital Entertainment Center KHA-01651B

Set-Up-Guide



Unpack the box



1 Set Top Box



2 Remote Control



3 Component Cable

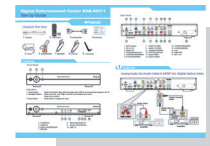

4 Set-Up-Guide

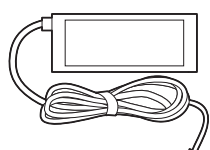

5 Adapter

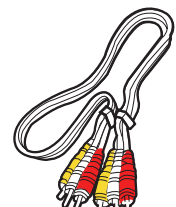

6 Audio/Video Cable



7 S-Video Cable

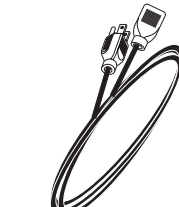

8 Power Cord



9 Antenna Cable

Features

Front Panel

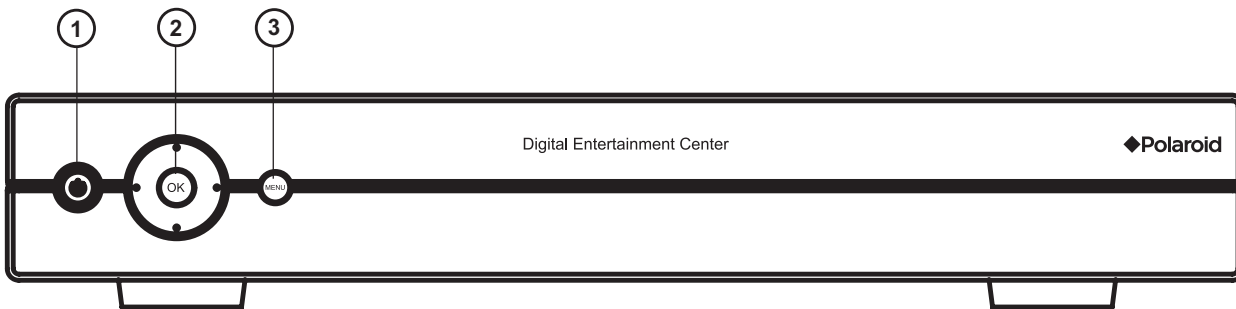

Indicators

- 1 Power Button :Press Power Red / Blue light illuminates when STB is on and sending a signal to the TV.
- 2 Navigation Button :Press Up, Down, Left, Right to access and navigate menu items. Press OK to confirm.
- 3 Menu Button :Press Button to display the menu.

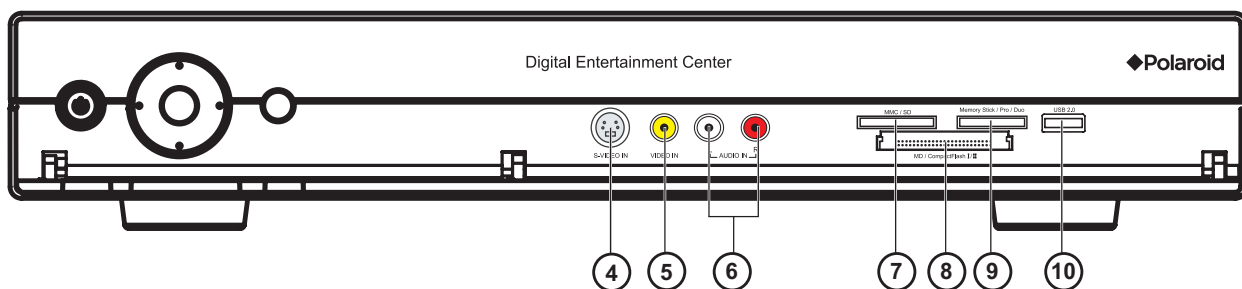

- 4 S-VIDEO IN
- 5 VIDEO IN
- 6 AUDIO IN(Fornt Left Right)
- 7 MMC/SD
- 8 MD/CompactFlash I/II
- 9 Memory Stick/Pro/Duo
- 10 USB 2.0

Rear Panel

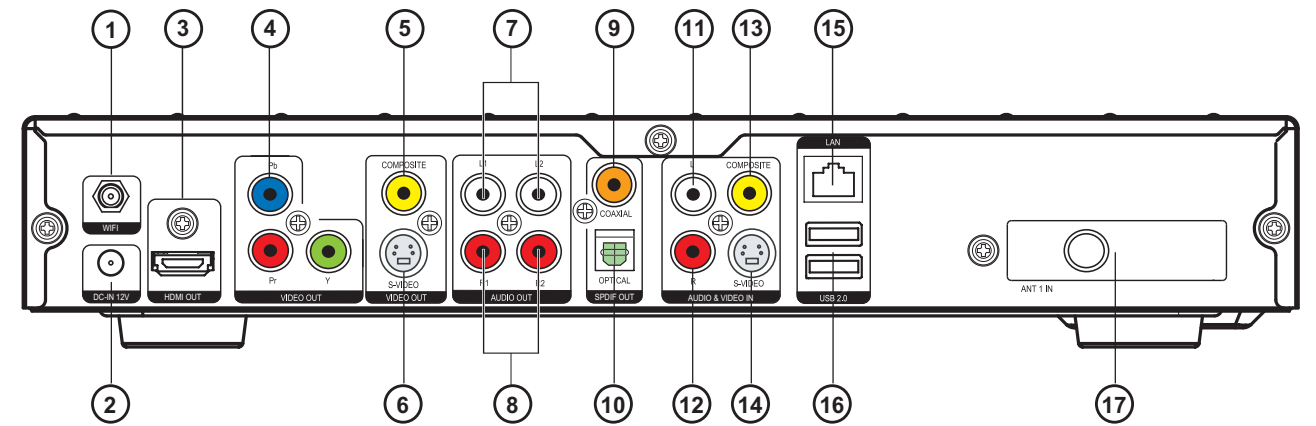

- 1 WIFI Antenna
- 2 DC IN 12V
- 3 HDMI OUT
- 4 Componert(VIDEO OUT)
- 5 COMPOSTIE(VIDEO OUT)
- 6 S-VIDEO(VIDEO OUT)
- 7 AUDIO OUT(Left)
- 8 AUDIO OUT(Right)
- 9 COAXIAL(SPDIF OUT)
- 10 OPTICAL(SPDIF OUT)
- 11 AUDIO IN(Left)
- 12 AUDIO IN(Right)
- 13 COMPOSTIE(VIDEO IN)
- 14 S-VIDEO(VIDEO IN)
- 15 LAN
- 16 USB 2.0x2
- 17 ANT 1 IN

1 Audio Out

Analog Audio Out (Audio Cable) & S/PDIF Out (Digital Optical Cable)

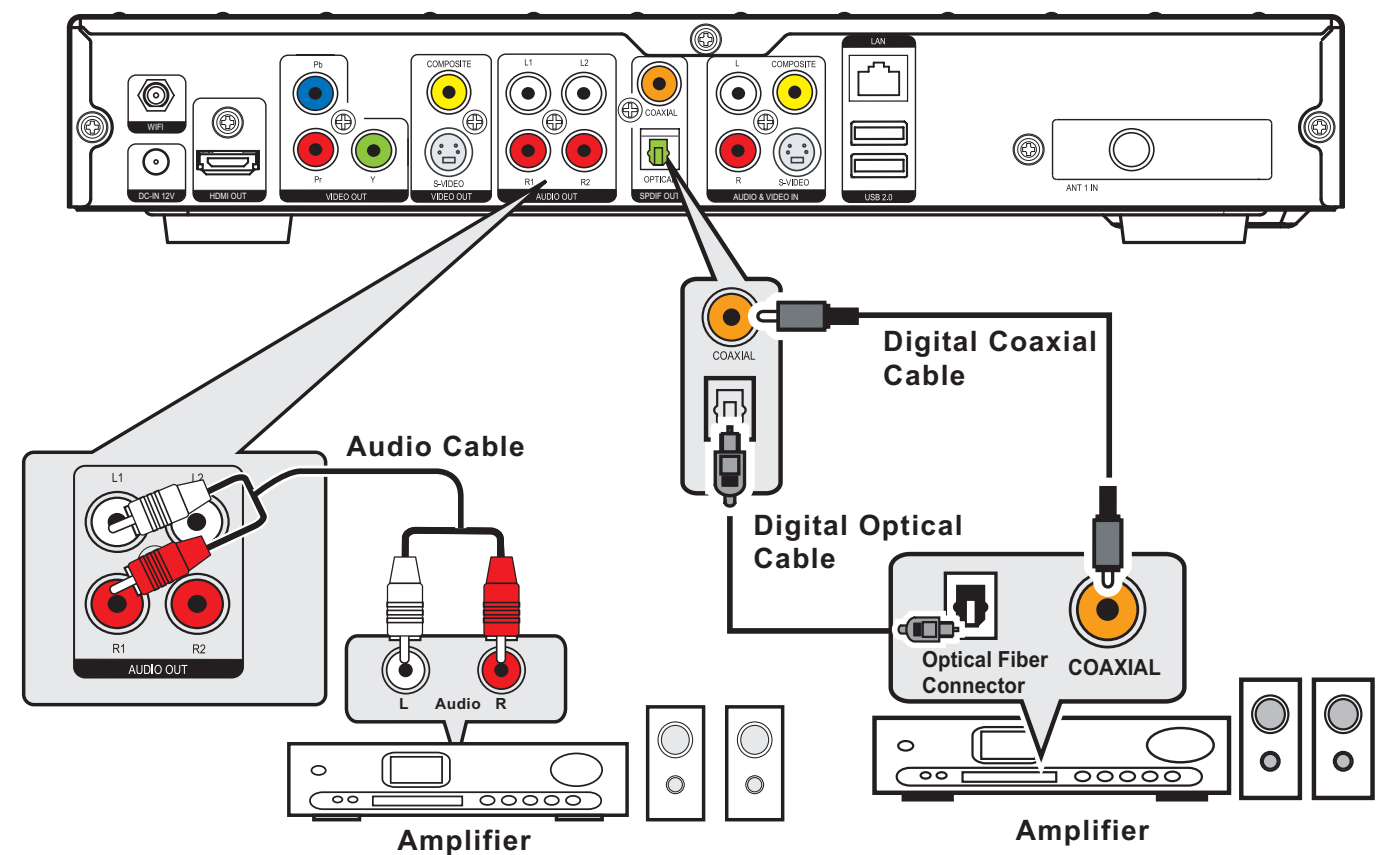

2 Video Out

Connecting Analog AV

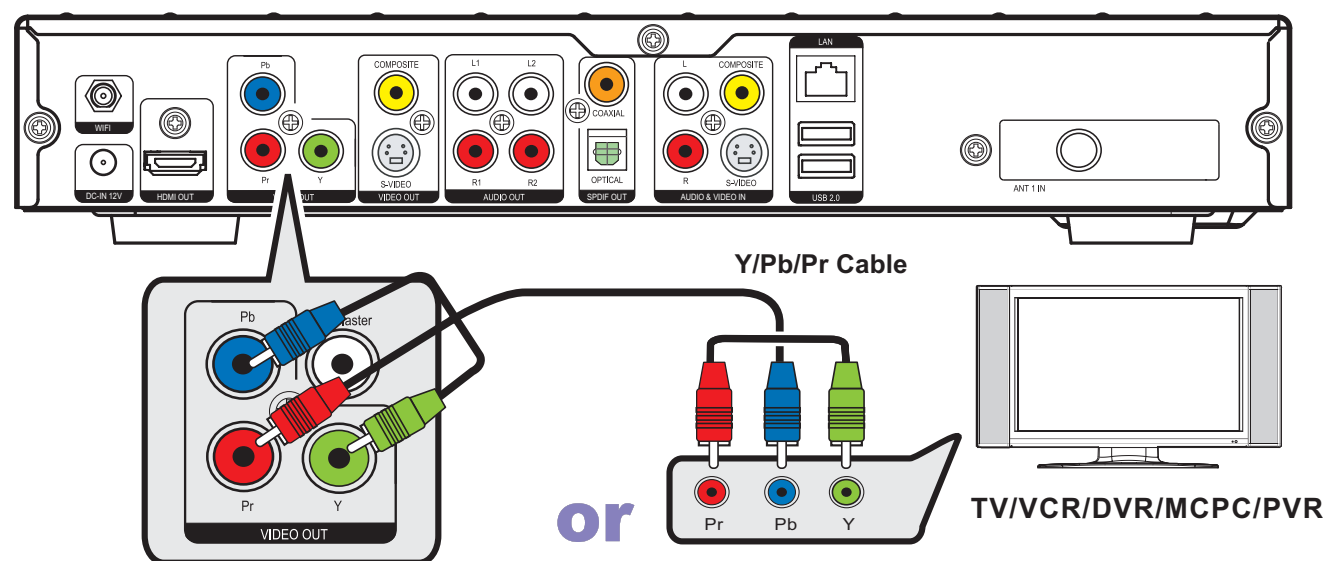

Connecting Analog AV & Connecting Digital AV (HDMI)

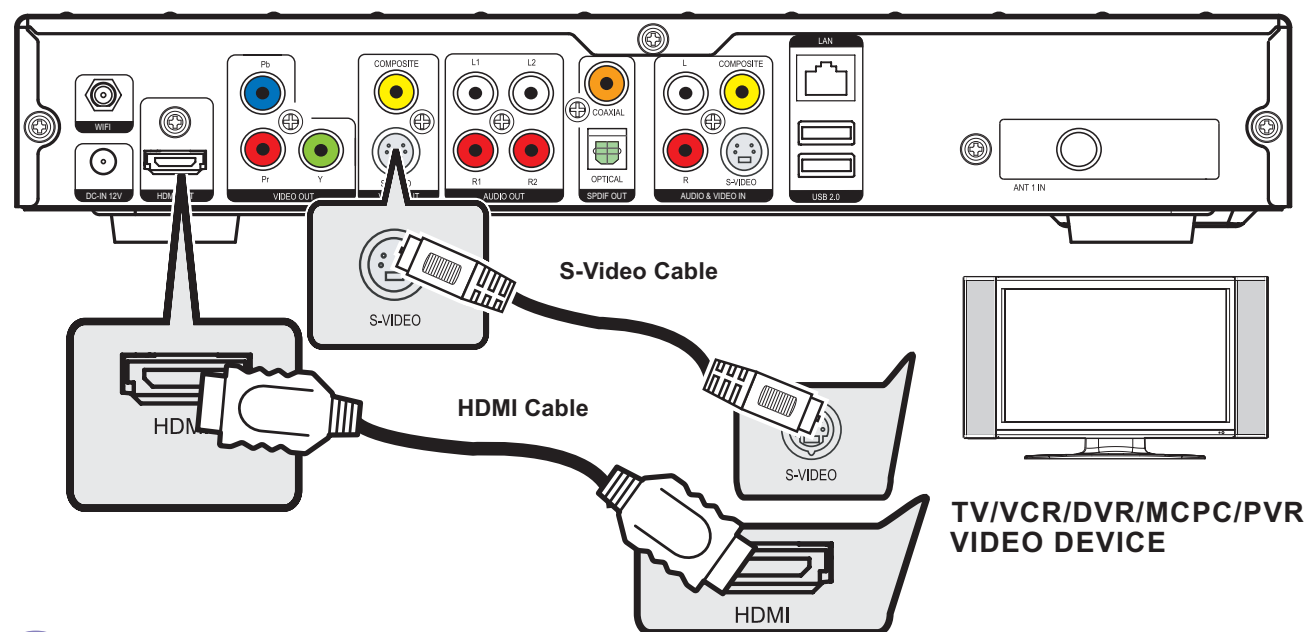

3 Local Area Network (LAN)

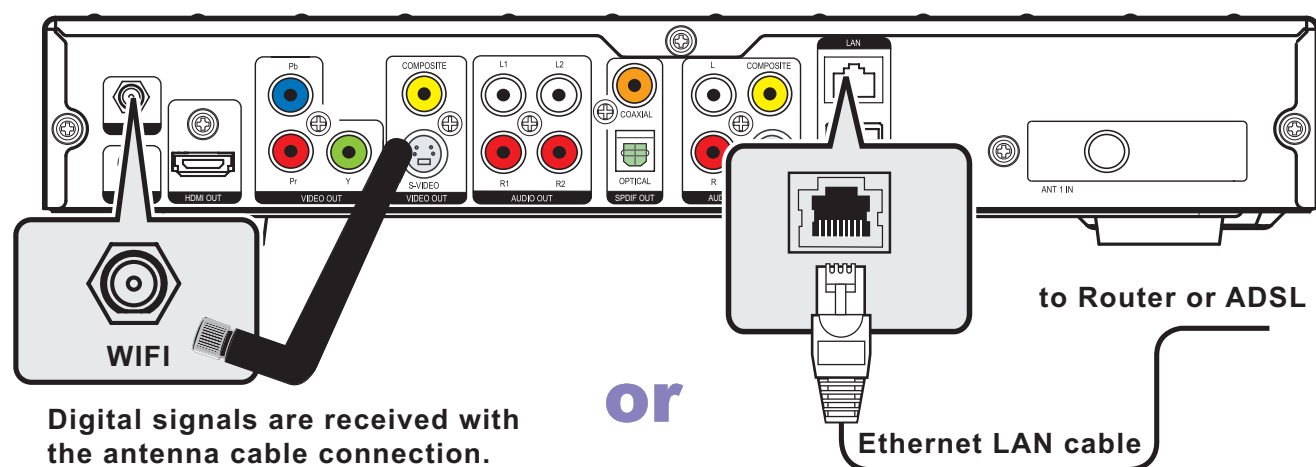

Digital signals are received with the antenna cable connection.

4 Plug in Power Cord and Turn Power On

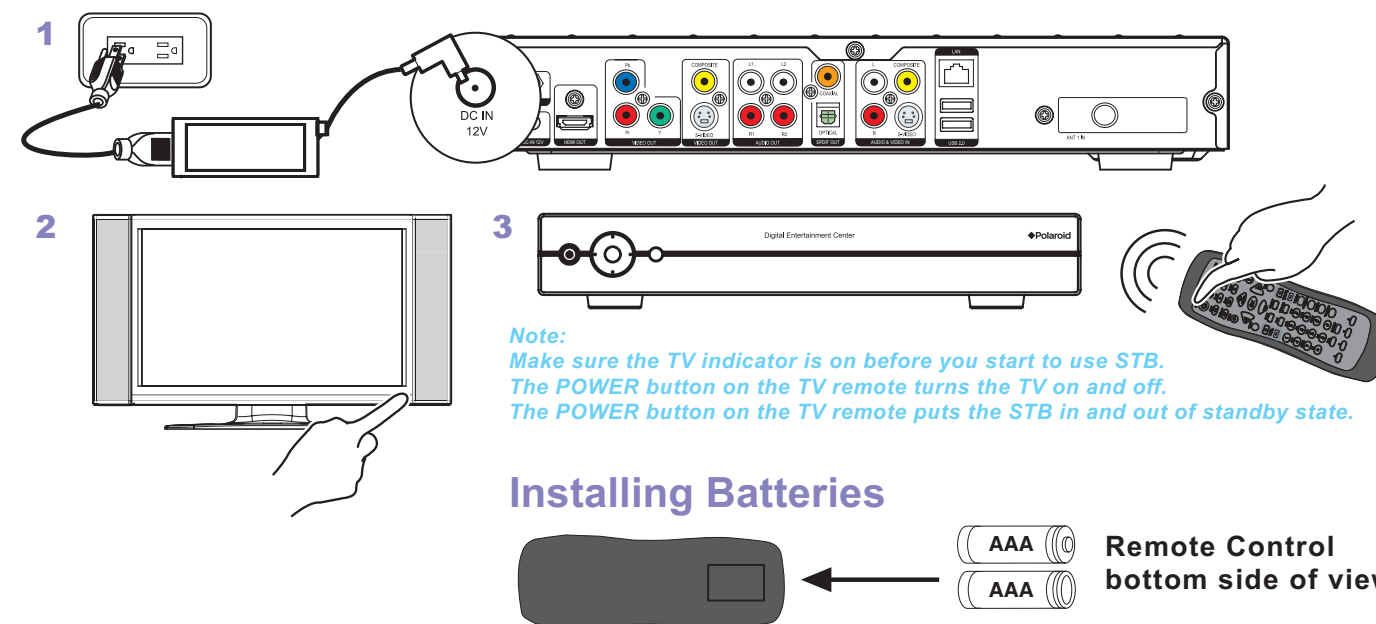

Safety Information

Before you getting started, please read the important safety information below.

AC Power Safety Warnings

The power supply is pre-set for the country/region in which you purchased DSTB (Digital Set Top Box). If you move to another country/region, please make sure you check its voltage requirements before plugging DSTB into an AC power outlet. Install the DSTB near an AC outlet. The AC power cord is DSTB's main AC disconnecting device and must be easily accessible at all times. For your safety, the power cord provided with your system has a grounded plug. Always use the power cord with a properly grounded wall outlet to avoid the risk of electrical shock.

Conventions used in this manual

- WARNING:** Information to prevent injury to yourself when trying to complete a task.
- CAUTION:** Information to prevent damage to the components when trying to complete a task.

Electrical Safety

- To prevent electrical shock hazard, disconnect the power cable from the electrical outlet before relocating the system.
- DO NOT OPEN THE CHASSIS ANY TIME.

Operation Safety

- Before using the product, make sure all cables are correctly connected and the power cables are not damaged. If you detect any damage, contact your Service Provider immediately.
- To avoid short circuits, keep paper clips, screws, and staples away from connectors, slots, sockets and circuitry.
- Avoid dust, humidity, and temperature extremes. Do not place the product in any area where it may become wet. Place the product on a stable surface.
- Slots and openings are provided for ventilation; to ensure reliable operation of the product and to protect it from overheating. These openings must not be blocked or covered. This product should never be placed near or over a radiator or heat register.
- Antenna coaxial screen must be probably earthed.

Federal Communication Commission Interference Statement

This equipment has been tested and found to comply with the limits for a Class B digital device, pursuant to Part 15 of the FCC Rules. These limits are designed to provide reasonable protection against harmful interference in a residential installation. This equipment generates, uses and can radiate radio frequency energy and, if not installed and used in accordance with the instructions, may cause harmful interference to radio communications. However, there is no guarantee that interference will not occur in a particular installation. If this equipment does cause harmful interference to radio or television reception, which can be determined by turning the equipment off and on, the user is encouraged to try to correct the interference by one of the following measures:

- Reorient or relocate the receiving antenna.
- Increase the separation between the equipment and receiver.
- Connect the equipment into an outlet on a circuit different from that to which the receiver is connected.
- Consult the dealer or an experienced radio/TV technician for help.

CAUTION:

Any changes or modifications not expressly approved by the grantee of this device could void the user's authority to operate the equipment.

FCC RF Radiation Exposure Statement

This equipment complies with FCC RF radiation exposure limits set forth for an uncontrolled environment. This equipment should be installed and operated with a minimum distance of 20cm between the radiator and your body.