

OPERATOR'S MANUAL



Model 390 Slush Freezer

Original Operating Instructions

048693- M

**6/01 (Original Publication)
(Updated 8/4/14)**

Complete this page for quick reference when service is required:

Taylor Distributor: _____

Address: _____

Phone: _____

Service: _____

Parts: _____

Date of Installation: _____

Information found on the data label:

Model Number: _____

Serial Number: _____

Electrical Specs: Voltage _____ Cycle _____

Phase _____

Maximum Fuse Size: _____ A

Minimum Wire Ampacity: _____ A

© 2001 Carrier Commercial Refrigeration, Inc.

048693- M

Any unauthorized reproduction, disclosure, or distribution of copies by any person of any portion of this work may be a violation of Copyright Law of the United States of America and other countries, could result in the awarding of Statutory Damages of up to \$250,000 (17 USC 504) for infringement, and may result in further civil and criminal penalties.

All rights reserved.



Taylor Company
a division of Carrier Commercial Refrigeration, Inc.
750 N. Blackhawk Blvd.
Rockton, IL 61072

Table of Contents

Section 1	To the Installer	1
	Installer Safety	1
	Site Preparation	1
	Water Connections (Water Cooled Units Only)	2
	Air Cooled Units	2
	Electrical Connections	2
	Refrigerant	3
Section 2	To the Operator	4
Section 3	Safety	5
Section 4	Operator Parts Identification	7
Section 5	Important: To the Operator	9
	Control Switch	9
	Indicator Light - “Mix Low”	9
	Indicator Light - “Mix Out”	9
	Optional Feature: Remote Continuous Fill System	9
Section 6	Operating Procedures	10
	Assembly	10
	Sanitizing	11
	Priming	11
	Closing Procedures	12
	Draining Product From The Freezing Cylinder	12
	Rinsing	12
	Cleaning	12
	Disassembly	13
	Brush Cleaning	14

Section 7	Important: Operator Checklist	15
	During Cleaning And Sanitizing	15
	Troubleshooting Guide	15
	Regular Maintenance Checks	15
	Winter Storage	16
Section 8	Troubleshooting Guide	17
Section 9	Parts Replacement Schedule	19
Section 10	Limited Warranty on Equipment	20
Section 11	Limited Warranty on Parts	22
Section 12	Parts List	25
	Wiring Diagrams	33

Note: Continuing research results in steady improvements; therefore, information in this manual is subject to change without notice.

Note: Only instructions originating from the factory or its authorized translation representative(s) are considered to be the original set of instructions.

© 2001 Carrier Commercial Refrigeration, Inc. (Original Publication)

(Updated August, 2014)

048693- M

Any unauthorized reproduction, disclosure, or distribution of copies by any person of any portion of this work may be a violation of Copyright Law of the United States of America and other countries, could result in the awarding of Statutory Damages of up to \$250,000 (17 USC 504) for infringement, and may result in further civil and criminal penalties.

All rights reserved.



Taylor Company
a division of Carrier Commercial Refrigeration, Inc.
750 N. Blackhawk Blvd.
Rockton, IL 61072

Section 1

To the Installer

The following information has been included in the manual as safety and regulatory guidelines. For complete installation instructions, please see the Installation Checklist.



This unit has many sharp edges that can cause severe injuries.

Installer Safety



In all areas of the world, equipment should be installed in accordance with existing local codes. Please contact your local authorities if you have any questions.

Care should be taken to ensure that all basic safety practices are followed during the installation and servicing activities related to the installation and service of Taylor equipment.

- Only authorized Taylor service personnel should perform installation and repairs on the equipment.
- Authorized service personnel should consult OSHA Standard 29CFR1910.147 or the applicable code of the local area for the industry standards on lockout/tagout procedures before beginning any installation or repairs.
- Authorized service personnel must ensure that the proper PPE is available and worn when required during installation and service.
- Authorized service personnel must remove all metal jewelry, rings, and watches before working on electrical equipment.



The main power supply(s) to the machine must be disconnected prior to performing any repairs. Failure to follow this instruction may result in personal injury or death from electrical shock or hazardous moving parts as well as poor performance or damage to the equipment.

Note: All repairs must be performed by an authorized Taylor Service Technician.

Site Preparation

Review the area the unit is to be installed in before uncrating the unit, making sure that all possible hazards the user or equipment may come into have been addressed.

For Indoor Use Only: This unit is designed to operate indoors, under normal ambient temperatures of 70°-75°F (21°-24°C). The freezer has successfully performed in high ambient temperatures of 104° (40°C) at reduced capacities.



This unit must **NOT** be installed in an area where a water jet or hose can be used. **NEVER** use a water jet or hose to rinse or clean the unit. Failure to follow this instruction may result in electrocution.



This unit must be installed on a level surface to avoid the hazard of tipping. Extreme care should be taken in moving this equipment for any reason. Two or more persons are required to safely move this unit. Failure to comply may result in personal injury or equipment damage.

Uncrate the unit and inspect it for damage. Report any damage to your Taylor Distributor.

This piece of equipment is made in the USA and has USA sizes of hardware. All metric conversions are approximate and vary in size.

Water Connections (Water Cooled Units Only)

An adequate cold water supply must be provided with a hand shut-off valve. On the underside of the base pan, two 3/8" I.P.S. (for single-head units) or two 1/2" I.P.S. (for double-head units) water connections for inlet and outlet have been provided for easy hook-up. 1/2" inside diameter water lines should be connected to the machine. (Flexible lines are recommended, if local codes permit.) Depending on local water conditions, it may be advisable to install a water strainer to prevent foreign substances from clogging the automatic water valve. There will be only one water "in" and one water "out" connection. **DO NOT** install a hand shut-off valve on the water "out" line! Water should always flow in this order: first through the automatic water valve; second, through the condenser; and third, through the outlet fitting to an **open trap drain**.



A back flow prevention device is required on the incoming water connection side. Please refer to the applicable National, State, and local codes for determining the proper configuration.

Air Cooled Units

Air cooled units require a minimum of 6" (152 mm) of clearance around both sides and 0" at the rear of the freezer. This is required to allow for adequate air flow across the condenser(s). Failure to allow adequate clearance can reduce the refrigeration capacity of the freezer and possibly cause permanent damage to the compressor(s).

Electrical Connections

Each freezer requires one power supply. Check the data label on the freezer for branch circuit overcurrent protection or fuse, circuit ampacity and electrical specifications. Refer to the wiring diagram provided inside of the electrical box, for proper power connections.

In the United States, this equipment is intended to be installed in accordance with the National Electrical Code (NEC), ANSI/NFPA 70-1987. The purpose of the NEC code is the practical safeguarding of persons and property from hazards arising from the use of electricity. This code contains provisions considered necessary for safety. Compliance therewith and proper maintenance will result in an installation essentially free from hazard!

In all other areas of the world, equipment should be installed in accordance with the existing local codes. Please contact your local authorities.



FOLLOW YOUR LOCAL ELECTRICAL CODES!



CAUTION: THIS EQUIPMENT MUST BE PROPERLY GROUNDED! FAILURE TO DO SO CAN RESULT IN SEVERE PERSONAL INJURY FROM ELECTRICAL SHOCK!



This unit is provided with an equipotential grounding lug that is to be properly attached to the rear of the frame by the authorized installer. The installation location is marked by the equipotential bonding symbol (5021 of IEC 60417-1) on both the removable panel and the equipment's frame.



- Stationary appliances which are not equipped with a power cord and a plug or another device to disconnect the appliance from the power source must have an all-pole disconnecting device with a contact gap of at least 3 mm installed in the external installation.
- Appliances that are permanently connected to fixed wiring and for which leakage currents may exceed 10 mA, particularly when disconnected, not used for long periods, or during initial installation, shall have protective devices such as a GFI to protect against the leakage of current, installed by authorized personnel to the local codes.
- Supply cords used with this unit shall be oil-resistant, sheathed flexible cable, not lighter than ordinary polychloroprene or other equivalent synthetic elastomer-sheathed cord (Code designation 60245 IEC 57) installed with the proper cord anchorage to relieve conductors from strain, including twisting, at the terminals and protect the insulation of the conductors from abrasion.

If the supply cord is damaged, it must be replaced by an authorized Taylor service technician in order to avoid a hazard.



Beater rotation must be clockwise as viewed looking into the freezing cylinder of the freezer.



Note: The following procedures should be performed by a trained service technician.

To correct the rotation on a three-phase unit, interchange any two incoming power supply lines at the freezer main terminal block only. To correct rotation on a single-phase unit, change the leads inside the beater motor. (Follow diagram printed on motor.)

Electrical connections are made directly to the terminal block. The terminal block is located in the control box located behind the left side panel.

Refrigerant



In consideration of our environment, Taylor uses only earth friendly HFC refrigerants. The HFC refrigerant used in this unit is R404A. This refrigerant is generally considered non-toxic and non-flammable, with an Ozone Depleting Potential (ODP) of zero (0).

However, any gas under pressure is potentially hazardous and must be handled with caution. NEVER fill any refrigerant cylinder completely with liquid. Filling the cylinder to approximately 80% will allow for normal expansion.



Use only R404A refrigerant that conforms to the AHRI standard 700 specification. The use of any other refrigerant may expose users and operators to unexpected safety hazards.



Refrigerant liquid sprayed onto the skin may cause serious damage to tissue. Keep eyes and skin protected. If refrigerant burns should occur, flush immediately with cold water. If burns are severe, apply ice packs and contact a physician immediately.



Taylor reminds technicians to be cautious of government laws regarding refrigerant recovery, recycling, and reclaiming systems. If you have any questions regarding these laws, please contact the factory Service Department.



WARNING: R404A refrigerant used in conjunction with polyolester oils is extremely moisture absorbent. When opening a refrigeration system, the maximum time the system is open must not exceed 15 minutes. Cap all open tubing to prevent humid air or water from being absorbed by the oil.

Section 2

To the Operator

The freezer you have purchased has been carefully engineered and manufactured to give you dependable operation. The Taylor Model 390, when properly operated and cared for, will produce a consistent quality product. Like all mechanical products, it will require cleaning and maintenance. A minimum amount of care and attention is necessary if the operating procedures outlined in this manual are followed closely.

This Operator's Manual should be read before operating or performing any maintenance on your equipment.

The Model 390 will NOT eventually compensate and correct for any errors during the set-up or filling operations. Thus, the initial assembly and priming procedures are of extreme importance. It is strongly recommended that personnel responsible for the equipment's operation, both assembly and disassembly, sit down together and go through these procedures in order to be properly trained and to make sure that no misunderstandings exist.

In the event you should require technical assistance, please contact your local authorized Taylor Distributor.

Note: Your Taylor warranty is valid only if the parts are authorized Taylor parts, purchased from the local authorized Taylor Distributor, and only if all required service work is provided by an authorized Taylor service technician. Taylor reserves the right to deny warranty claims on units or parts if non-Taylor approved parts or incorrect refrigerant were installed in the unit, system modifications were performed beyond factory recommendations, or it is determined that the failure was caused by abuse, misuse, neglect, or failure to follow all operating instructions. For full details of your Taylor Warranty, please see the Limited Warranty section in this manual.



If the crossed out wheeled bin symbol is affixed to this product, it signifies that this product is compliant with the EU Directive as well as other similar legislation in effect after August 13, 2005. Therefore, it must be collected separately after its use is completed, and cannot be disposed as unsorted municipal waste.

The user is responsible for returning the product to the appropriate collection facility, as specified by your local code.

For additional information regarding applicable local laws, please contact the municipal facility and/or local distributor.

Compressor Warranty Disclaimer

The refrigeration compressor(s) on this unit are warranted for the term stated in the Limited Warranty section in this manual. However, due to the Montreal Protocol and the U.S. Clean Air Act Amendments of 1990, many new refrigerants are being tested and developed, thus seeking their way into the service industry. Some of these new refrigerants are being advertised as drop-in replacements for numerous applications. It should be noted that in the event of ordinary service to this unit's refrigeration system, **only the refrigerant specified on the affixed data label should be used.** The unauthorized use of alternate refrigerants will void your Taylor compressor warranty. It is the unit owner's responsibility to make this fact known to any technician he employs.

It should also be noted that Taylor does not warrant the refrigerant used in its equipment. For example, if the refrigerant is lost during the course of ordinary service to this machine, Taylor has no obligation to either supply or provide its replacement either at billable or unbillable terms. Taylor does have the obligation to recommend a suitable replacement if the original refrigerant is banned, obsoleted, or no longer available during the five year warranty of the compressor.

Taylor will continue to monitor the industry and test new alternates as they are being developed. Should a new alternate prove, through our testing, that it would be accepted as a drop-in replacement, then the above disclaimer would become null and void. To find out the current status of an alternate refrigerant as it relates to your compressor warranty, call the local Taylor Distributor or the Taylor Factory. Be prepared to provide the Model/Serial Number of the unit in question.

We at Taylor are concerned about the safety of the operator when he or she comes in contact with the freezer and its parts. Taylor has gone to extreme efforts to design and manufacture built-in safety features to protect both you and the service technician. As an example, warning labels have been attached to the freezer to further point out safety precautions to the operator.



IMPORTANT - Failure to adhere to the following safety precautions may result in severe personal injury. Failure to comply with these warnings may damage the machine and its components. Component damage will result in part replacement expense and service repair expense.

To Operate Safely:



DO NOT operate the freezer without reading this Operator Manual. Failure to follow this instruction may result in equipment damage, poor freezer performance, health hazards, or personal injury.



This unit is to be used only by trained personnel. It is not intended for use by children or people with reduced physical, sensory, or mental capabilities, or lack of experience and knowledge. Where limited equipment operation is allowed for public use, such as a self-serve application, supervision or instruction concerning the use of the appliance by a person responsible for their safety is required. Children should be supervised to ensure that they do not play with the appliance.



This unit is provided with an equipotential grounding lug that is to be properly attached to the rear of the frame by the authorized installer. The installation location is marked by the equipotential bonding symbol (5021 of IEC 60417-1) on both the removable panel and the equipment's frame.



- **DO NOT** operate the freezer unless it is properly grounded.
- **DO NOT** operate the freezer with larger fuses than specified on the freezer data label.
- All repairs must be performed by an authorized Taylor service technician.
- The main power supplies to the machine must be disconnected prior to performing any repairs.
- Cord Connected Units: Only Taylor authorized service technicians may install a plug on this unit.
- Stationary appliances which are not equipped with a power cord and a plug or another device to disconnect the appliance from the power source must have an all-pole disconnecting device with a contact gap of at least 3 mm installed in the external installation.
- Appliances that are permanently connected to fixed wiring and for which leakage currents may exceed 10 mA, particularly when disconnected, not used for long periods, or during initial installation, shall have protective devices such as a GFI to protect against the leakage of current, installed by authorized personnel to the local codes.
- Supply cords used with this unit shall be oil-resistant, sheathed flexible cable, not lighter than ordinary polychloroprene or other equivalent synthetic elastomer-sheathed cord (Code designation 60245 IEC 57) installed with the proper cord anchorage to relieve conductors from strain, including twisting, at the terminals and protect the insulation of the conductors from abrasion.

If the supply cord is damaged, it must be replaced by an authorized Taylor service technician in order to avoid a hazard.

Failure to follow these instructions may result in electrocution. Contact your local authorized Taylor Distributor for service.



DO NOT use a water jet to clean or rinse the freezer. Failure to follow these instructions may result in serious electrical shock.



- **DO NOT** allow untrained personnel to operate this machine.
- **DO NOT** operate the freezer unless all service panels and access doors are restrained with screws.
- **DO NOT** remove any internal operating parts (examples: freezer door, beater, scraper blades, etc.) unless all control switches are in the OFF position.

Failure to follow these instructions may result in severe personal injury to fingers or hands from hazardous moving parts.



This unit has many sharp edges that can cause severe injuries.

- **DO NOT** put objects or fingers in the door spout. This may contaminate the product and cause severe personal injury from blade contact.
- **USE EXTREME CAUTION** when removing the beater assembly. The scraper blades are very sharp.



This freezer must be placed on a level surface. Failure to comply may result in personal injury or equipment damage.



Access to the service area of the unit is restricted to persons having knowledge and practical experience with the appliance, in particular as far as safety and hygiene are concerned.



Cleaning and sanitizing schedules are governed by your state or local regulatory agencies and must be followed accordingly. Please refer to the cleaning section of this manual for the proper procedure to clean this unit.



This unit is designed to maintain product temperature under 41°F (5°C). Any product being added to this unit must be below 41°F (5°C). Failure to follow this instruction may result in health hazards and poor freezer performance.

DO NOT obstruct air intake and discharge openings: 6" (152 mm) minimum air space on both sides, and 0" at the rear of the freezer. Failure to follow this instruction may cause poor freezer performance and damage to the machine.

For Indoor Use Only: This unit is designed to operate indoors, under normal ambient temperatures of 70°-75°F (21°-24°C). The unit has successfully performed in high ambient temperatures of up to 104°F (40°C) at reduced capacities.

DO NOT run the unit without product. Failure to follow this instruction can result in damage to the unit.

NOISE LEVEL: Airborne noise emission does not exceed 78 dB(A) when measured at a distance of 1.0 meter from the surface of the machine and at a height of 1.6 meters from the floor.

Section 4

Operator Parts Identification

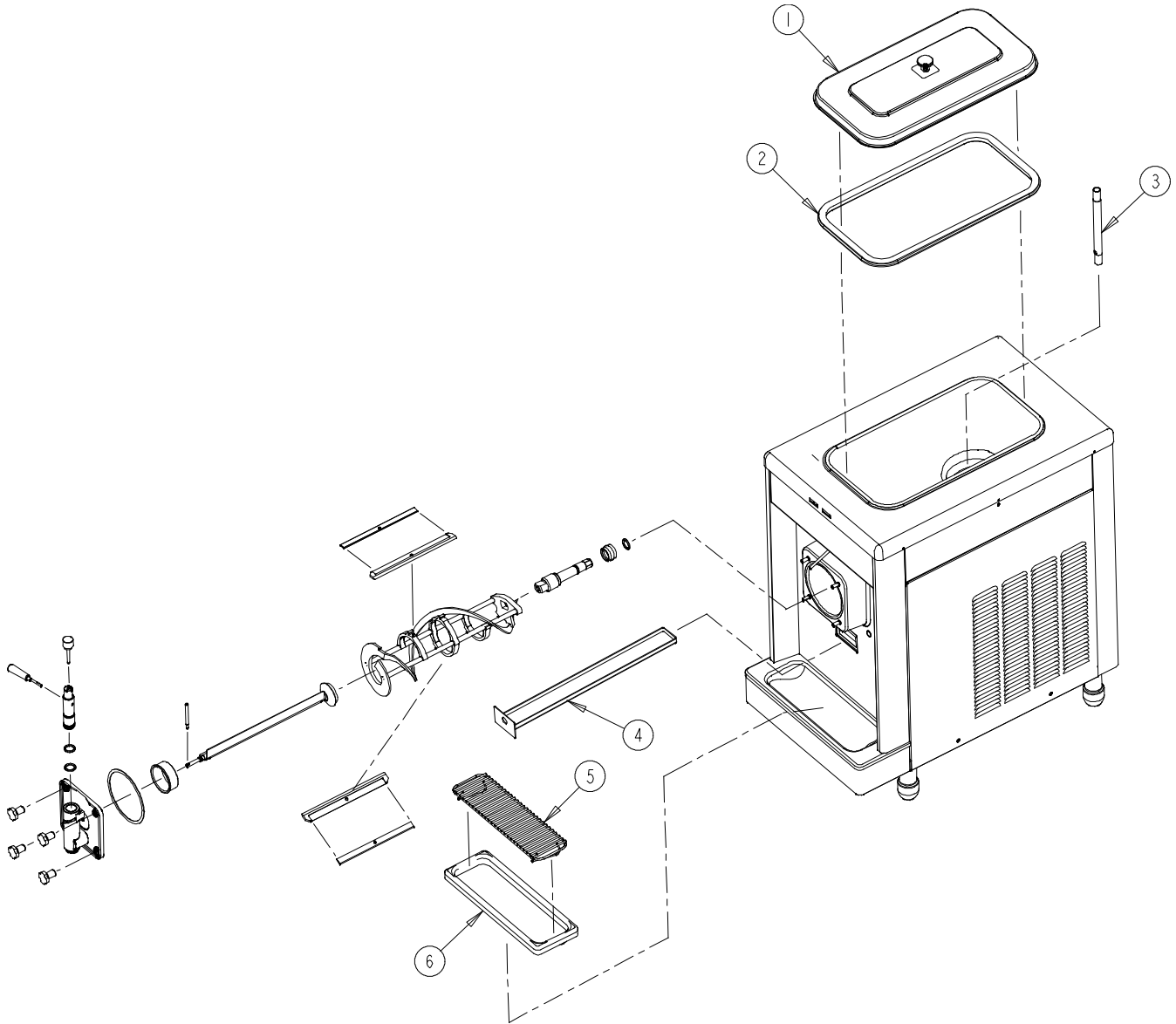

Item	Description	Part Number
1	Hopper Cover	X38458
2	Gasket- Hopper Cover	038375
3	Feed Tube	015176- 9
4	Drip Pan	035034
5	Splash Shield	046177
6	Drip Tray	046275

Beater Assembly

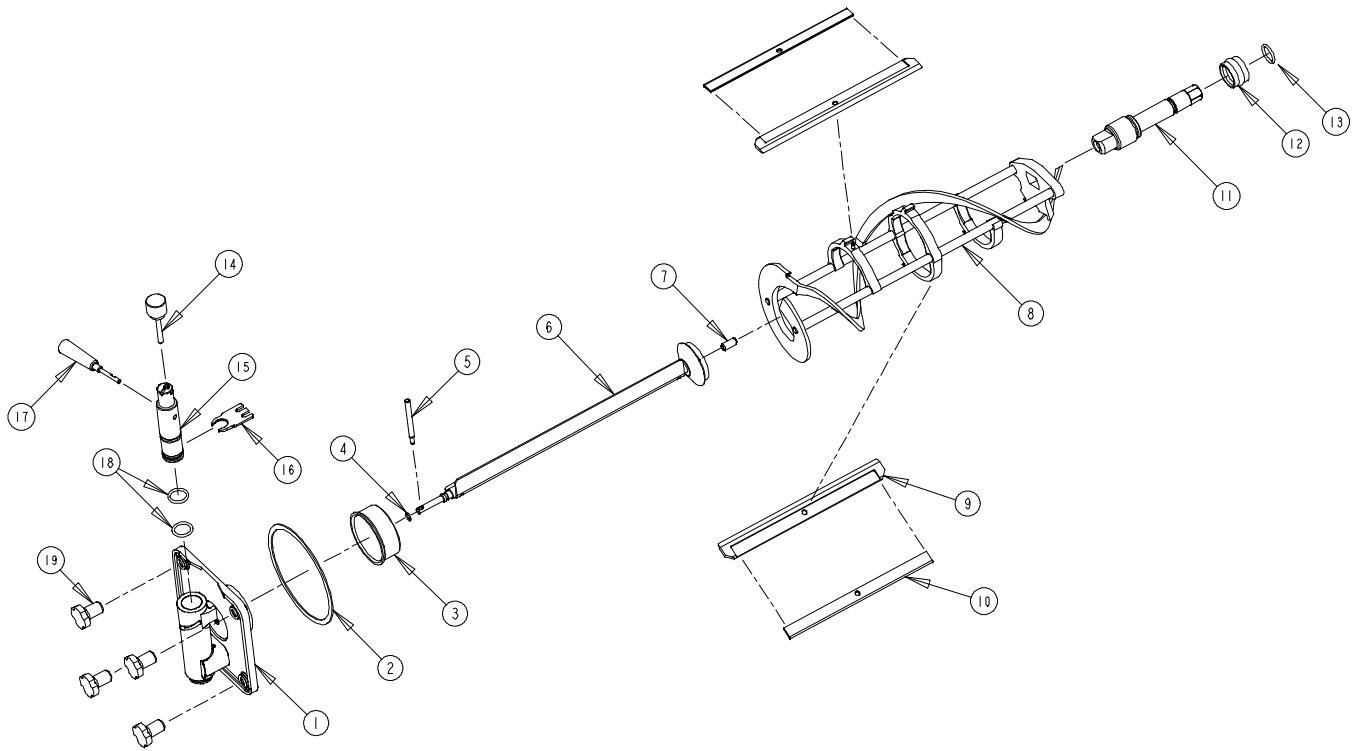

Item	Description	Part Number
1	Freezer Door	X47982
2	Gasket- Door	014030
3	Front Bearing	013116
4	O- Ring- Baffle	018550
5	Baffle Arm	047729
6	Baffle	X47731
7	Guide Bearing	014496
8	Beater	X46233
9	Scraper Blade	046237
10	Clip- Scraper Blade	046238

Item	Description	Part Number
11	Beater Shaft	036412
12	Seal- Beater Shaft	032560
13	O- Ring- Beater Shaft	025307
14	Valve Handle Pin	X25929
15	Draw Valve	047734
16	Ice Buster	047735
17	Draw Handle	X47384
18	O- Ring- Draw Valve (2)	032504
19	Stud Nut	029880

Section 5

Important: To the Operator

Control Switch

The center position is “OFF”. The “WASH” position activates the beater motor only. The “AUTO” position allows the beater motor and compressor to run.

Indicator Light - “Mix Low”

Located on the front of the machine is a mix level indicating light. When the light is flashing, it indicates that the mix hopper has a low supply of product and should be refilled as soon as possible. Neglecting to add mix when the light comes on will cause the machine to sway and may eventually cause damage to the beater assembly and freezer door.

Indicator Light - “Mix Out”

Also located on the front of the machine is a mix out indicating light. When the light is flashing, it indicates that the hopper is empty and the mix supply needs replenishing. To prevent damage to the unit, refrigeration discontinues automatically when the mix out indicator lights.

Optional Feature: Remote Continuous Fill System

If your Model 390 Taylor Freezer has been factory equipped with a Remote Continuous Fill System, the mix supply to the freezer will be replenished automatically from mix tanks located in a remote location.

When the “Mix Out” indicator lights, the mix supply in the freezer hopper will be replenished automatically.

To start the unit after cleaning:

1. Place the power switch in the “Wash” position.
2. Press the “Fill” button, located under the control channel, until the freezing cylinder is at least half full.
Note: Do not remove the hopper cover while the unit is filling with mix, as some splashing may occur.
3. Once the freezing cylinder is at least half full, place the power switch in the “Auto” mode and the hopper will be filled automatically, and the fill system will discontinue.
4. Place the mix feed tube into the mix inlet.
5. Raise the draw switch arm to initiate refrigeration. When the refrigeration stops, the product is ready to serve.

Recommended Pressure: 12 - 15 PSI (83 - 103 kPa)

IMPORTANT: Do not exceed 15 PSI or excessive splashing will occur.

Section 6

Operating Procedures

Following are step-by-step operating procedures for the model 390 slush freezer. This unit has a 20 quart (18.9 liter) mix hopper and the freezing cylinder holds 7 quarts (6.6 liters) of slush product.

We begin our instructions at the point where we enter the store in the morning and find the parts disassembled and laid out to air dry from the previous night's brush cleaning.

These opening procedures will show you how to assemble these parts into the freezer, sanitize them and prime the freezer with the slush base you have selected in preparation to serve your first portion.

If you are disassembling the machine for the first time or need information to get to this starting point in our instructions, turn to "Disassembly" on page 13, and start there.

Assembly



BE SURE THE CONTROL SWITCH IS IN THE "OFF" POSITION. Failure to do so may cause injury from electrocution or hazardous moving parts.

Note: When lubricating parts, use an approved food grade lubricant (example: Taylor Lube).

Step 1

Install beater drive shaft. Slide the o-ring into the first groove on the drive shaft. Lubricate the groove, o-ring, and shaft portion that comes in contact with the bearing on the beater drive shaft. **DO NOT** lubricate the hex end of the drive shaft. Slide the seal over the shaft and groove until it snaps into place. Fill the inside portion of the seal with 1/4" more lubricant and evenly lubricate the flat side of the seal that fits onto the rear shell bearing.

Install the drive shaft into the freezing cylinder, hex end first, and into the rear shell bearing until the seal fits securely over the rear shell bearing. Be certain the drive shaft fits into the drive coupling without binding.

Step 2

Before installing the beater assembly, check the scraper blades for any nicks or signs of wear. If any nicks are present or if the blade is worn, replace both blades. If blades are in good condition, install the scraper blade clip over the scraper blade. Place the rear scraper blade over the rear holding pin (knife edge to the outside). Holding the blade on the beater, turn it over and install the front blade the same way.

Holding the blades in position, insert the beater assembly into the freezing cylinder and slide into position over the drive shaft. Turn the beater slightly to be certain that the beater is properly seated. When in position, the beater will not protrude beyond the front of the freezing cylinder.

Step 3

Install the baffle assembly. Lubricate the o-ring, and install it on the front end of the baffle assembly. Install the guide bearing on the rear end of the baffle assembly.

Install the bearing end of the baffle assembly into the pilot hole in the drive shaft.

Step 4

Assemble the freezer door with the "Ice Buster" (door spout clearing device). To assemble the door with the ice buster, install the o-rings on the draw valve and lubricate. (See illustrations on page 13.)

Insert the draw valve into the door, leaving approximately 1/2" of the valve sticking out the top of the door.

Rotate the draw valve so the flats on the top of the draw valve are perpendicular to the door face (see illustration).

Insert the ice buster through the door spout and into the slot located just above the lower o-ring.

With the ice buster in place, rotate the draw valve to allow installation of the draw handle. This will lock the ice buster in place. Install the draw handle pin, and close the draw valve by moving the handle to the left.

Place the large rubber gasket into the groove on the back side of the freezer door.

Slide the white plastic front bearing onto the bearing hub making certain that the flanged end of the bearing is resting against the freezer door. Do not lubricate the door gasket or front bearing.

Step 5

Install the freezer door. Place the front end of the baffle into the hole in the center of the door. Position the door onto the four studs on the front of the freezing cylinder and push the door into place. Install the four handscrews onto the studs and tighten them equally in a criss-cross pattern to insure the door is snug. **DO NOT** over-tighten the handscrews.

Note: If the freezer door does not go into place easily, position open end of beater assembly in the 11 o'clock position.

Step 6

Rotate the baffle assembly so the hole in the end of the shaft is vertical. Insert the baffle arm between the draw valve spout supports and into the hole in the baffle assembly.

Note: During operation, the baffle arm rests on the spout support.

Step 7

Install the rear drip pan. Slide the long drip pan into the hole in the front panel.

Step 8

Install the front drip tray and the splash shield under the door spout.

Step 9

Lay the hopper gasket and feed tube in the bottom of the mix hopper.

Sanitizing

Step 1

Prepare an approved 100 PPM sanitizing solution (examples: 2- 1/2 gal. [9.5 liters] of Kay- 5® or 2 gal. [7.6 liters] of Stera- Sheen®). USE WARM WATER AND FOLLOW THE MANUFACTURER'S SPECIFICATIONS.

Step 2

Pour the sanitizing solution into the hopper and allow it to flow into the freezing cylinder.

Step 3

While the solution is flowing into the freezing cylinder, brush clean the mix hopper, mix inlet hole, feed tube and mix level sensing probes.

Step 4

Place the control switch in the "WASH" position. This will cause the sanitizing solution in the freezing cylinder to be agitated. Allow the solution to agitate for five minutes.

Step 5

Place an empty pail beneath the door spout and move the draw handle to the right. Draw off all the sanitizing solution. When the sanitizer stops flowing from the door spout, move the draw handle to the left and place the control switch in the "OFF" position.

Step 6

With sanitized hands, assemble the hopper gasket around the top edge of the mix hopper. Stand the feed tube in the corner of the hopper.

Priming

Note: If your freezer is equipped with the Remote Continuous Fill System, replace the following Priming instructions with the information on page 9.

Step 1

With a pail beneath the door spout, move the draw handle to the right. Fill the hopper with FRESH slush product and allow it to flow into the freezing cylinder. This will force out any remaining sanitizing solution. When full strength mix is flowing from the door spout, move the draw handle to the left.

Step 2

When the slush product has stopped bubbling down into the freezing cylinder, install the feed tube in the mix inlet hole.

Step 3

Place the control switch in the "AUTO" position. To begin refrigeration, raise the rod resting on top of the valve handle pin. When the unit cycles off, the product will be at serving viscosity.

Step 4

Place the hopper cover into position.

Closing Procedures

To disassemble the model 390, the following items will be needed:

- Two cleaning pails
- Sanitized stainless steel rerun can with lid
- Necessary brushes (provided with freezer)
- Cleaner
- Single service towels

Draining Product From The Freezing Cylinder

Step 1

Place the control switch in the “OFF” position as far ahead of cleaning time as possible. This will allow frozen product to soften for easier cleaning.

Step 2

Remove the hopper cover, gasket, and feed tube. Take these parts to the sink for cleaning.

Step 3

If local health codes permit the use of rerun, place a sanitized, NSF approved stainless steel rerun container beneath the door spout. Place the control switch in the “WASH” position and move the draw handle to the right. When all the product stops flowing from the door spout, move the draw handle to the left and place the control switch in the “OFF” position. Place a sanitized lid on the rerun container and place it in the walk-in cooler.

(Note: For additional information regarding the proper use of rerun, see item 7 on page 15.)

Note: If local health codes **DO NOT** permit the use of rerun, the product must be discarded. Follow the instructions in the previous step, except drain the product into a pail and properly discard the mix.



ALWAYS FOLLOW LOCAL HEALTH CODES.

Rinsing

Step 1

Pour two gallons (7.6 liters) of **cool**, clean water into the mix hopper. With the brushes provided, scrub the mix hopper, mix inlet hole and mix level sensing probes.

Step 2

With a pail beneath the door spout, place the control switch in the “WASH” position and move the draw handle to the right. Drain all the rinse water from the freezing cylinder. When the rinse water stops flowing from the door spout, move the draw handle to the left and place the control switch in the “OFF” position.

Repeat this procedure until the rinse water being drawn from the freezing cylinder is **clear**.

Cleaning

Step 1

Prepare an approved 100 PPM cleaning solution (examples: 2- 1/2 gal. [9.5 liters] of Kay- 5® or 2 gal. [7.6 liters] of Stera- Sheen®). **USE WARM WATER AND FOLLOW THE MANUFACTURER’S SPECIFICATIONS.**

Step 2

Pour the cleaning solution into the hopper and allow it to flow into the freezing cylinder.

Step 3

While the solution is flowing into the freezing cylinder, brush clean the mix hopper, mix inlet hole, and mix level sensing probes.

Step 4

Place the control switch in the “WASH” position. This will cause the cleaning solution to be agitated.

Step 5

Place an empty pail beneath the door spout and move the draw handle to the right. Draw off all of the cleaning solution. When the solution stops flowing from the door spout, move the draw handle to the left and place the control switch in the “OFF” position.

Disassembly



BE SURE THE CONTROL SWITCH IS IN THE "OFF" POSITION. Failure to do so may cause injury from electrocution or hazardous moving parts.

Step 1

Remove the handscrews, freezer door, baffle assembly, beater assembly, scraper blades, and drive shaft from the freezing cylinder. Take these parts to the sink for cleaning.

Step 2

Remove the front drip tray and splash shield and take them to the sink for cleaning.

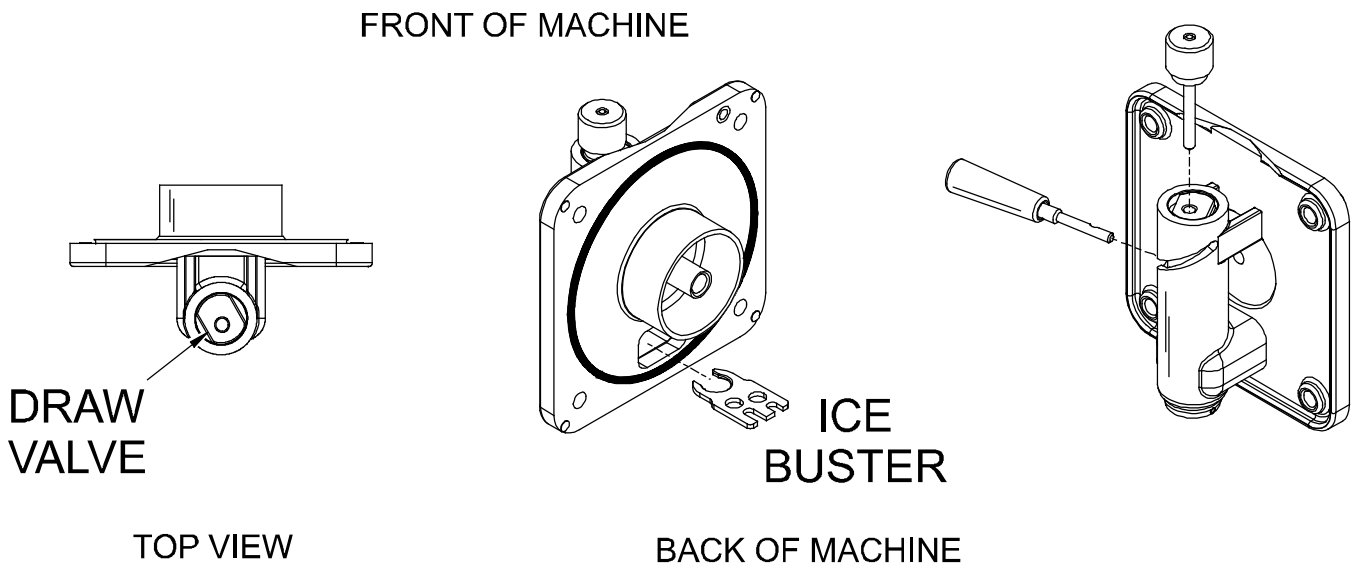

Brush Cleaning

Step 1

Prepare a sink with an approved cleaning solution (examples: Kay-5® or Stera-Sheen®). USE WARM WATER AND FOLLOW THE MANUFACTURER'S SPECIFICATIONS. (If another approved cleaner is used, dilute according to label instructions.)

IMPORTANT: Follow label directions, as too STRONG of a solution can cause parts damage, while too MILD of a solution will not provide adequate cleaning.) Make sure all brushes provided with the freezer are available for brush cleaning.

Step 2

Remove the o-ring and seal from the drive shaft.

Note: To remove o-rings, use a single service towel to grasp the o-ring. Apply pressure in an upward direction until the o-ring pops out of its groove. With the other hand, push the top of the o-ring forward and it will roll out of the groove and can be easily removed. If there is more than one o-ring to be removed, always remove the rear o-ring first. This will allow the o-ring to slide over the forward rings without falling into the open grooves.

Step 3

Remove the draw valve handle and pin, ice buster, draw valve, front bearing and gasket from the freezer door. Remove the scraper blade clips from the scraper blades. Remove the two o-rings from the draw valve, and the o-ring and guide bearing from the baffle assembly.

Step 4

Return to the freezer with a small amount of cleaning solution. Brush clean the rear shell bearing at the back of the freezing cylinder with the black bristle brush.

Step 5

Remove the rear drip pan.

Note: If the drip pan is filled with an excessive amount of mix, it is an indication that the drive shaft o-ring, seal or both should be replaced or properly lubricated.

Step 6

Thoroughly brush clean all disassembled parts in the cleaning solution making sure all lubricant and mix film is removed. Place all the cleaned parts on a clean, dry surface to air dry.

Step 7

Wipe clean all exterior surfaces of the freezer.

Section 7 Important: Operator Checklist

During Cleaning And Sanitizing



ALWAYS FOLLOW LOCAL HEALTH CODES.

Cleaning and sanitizing schedules are governed by federal, state, or local regulatory agencies, and must be followed accordingly. If the unit has a “Standby mode”, it must not be used in lieu of proper cleaning and sanitizing procedures and frequencies set forth by the ruling health authority. The following check points should be stressed during the cleaning and sanitizing operations.



CLEANING AND SANITIZING MUST BE PERFORMED DAILY.

Troubleshooting Guide

- 1. Thoroughly clean and sanitize the machine regularly, including complete disassembly and brush cleaning.
- 2. Use all brushes supplied for thorough cleaning. The brushes are specially designed to reach all mix passageways.
- 3. Use the white bristle brush to clean the mix inlet hole which extends from the mix hopper down to the rear of the freezing cylinder.
- 4. Use the black bristle brush to thoroughly clean the rear shell bearing at the rear of the freezing cylinder. Be sure to have a generous amount of cleaning solution on the brush.
- 5. Properly prepare the cleaning and sanitizing solutions. Read and follow label directions carefully. Too strong of a solution may damage the parts and too weak of a solution will not do an adequate job of cleaning or sanitizing.
- 6. Using a screwdriver and cloth towel, keep the female hex drive socket and rear shell bearing clean and free of lubricant and mix deposits.
- 7. IF LOCAL HEALTH CODES PERMIT THE USE OF RERUN, make sure the rerun is stored in a sanitized, covered stainless steel container and used the following day. Discard all rerun once a week.

Regular Maintenance Checks

- 1. Rotate scraper blades to allow both sides of the knife edge to wear evenly. This will contribute to self-sharpening and help maintain fast efficient freezing.
- 2. Replace scraper blades that are nicked or damaged.
- 3. Before installing the beater, be certain that scraper blades are properly attached over the beater pins.
- 4. Dispose of o-rings or seals that are worn, torn or fit too loosely and replace with new ones.
- 5. Follow all lubrication procedures as outlined in the “Assembly” instructions of this manual.
- 6. Check rear shell bearing for signs of wear (excessive mix leakage in rear drip pan) and be certain it is properly cleaned.
- 7. Check the condenser for accumulation of dirt and lint. Dirty condensers will reduce the efficiency and capacity of the machine. Condensers should be cleaned monthly with a soft brush. Never use screwdrivers or other metal probes to clean between the fins.
Note: For machines equipped with an air filter, it will be necessary to vacuum clean the filters on a monthly schedule.
- 8. If your machine is water cooled, check the water lines for kinks or leaks. Kinks can occur when the machine is moved back and forth for cleaning or maintenance purposes. Deteriorated or cracked water lines should be replaced only by an authorized Taylor mechanic.

Winter Storage

If the place of business is to be closed during the winter months, it is important to protect the freezer by following certain precautions, particularly if the building is to be left unheated and subject to freezing conditions.

Disconnect the freezer from the main power source to prevent possible electrical damage.

On water cooled freezers, disconnect the water supply. Relieve pressure on spring in water valve. Use air pressure on the outlet side to blow out any remaining water in the condenser. **This is extremely important.** Failure to follow this procedure may cause severe and costly damage to the refrigeration system.

Wrap detachable parts of the freezer such as beater and blades, drive shaft, baffle and freezer door, and place in a protected dry place. Rubber trim parts and gaskets can be protected by wrapping with moisture-proof paper. All parts should be thoroughly cleaned of dried mix or lubrication accumulations which attract mice and other vermin.

Your local Taylor Distributor can perform this service for you.

Section 8

Troubleshooting Guide

PROBLEM	PROBABLE CAUSE	REMEDY	PAGE REF.
1. No product being dispensed with draw valve opened.	a. Improper mixing of product.	a. Carefully follow directions for mixing product.	--
	b. Mix low condition.	b. Add mix to mix hopper.	9
2. Product too thin.	a. Improper mixing of product.	a. Carefully follow directions for mixing product.	--
	b. Missing, incorrectly installed or bad scraper blades.	b. Replace or install correctly.	10
	c. Consistency control needs adjusting.	c. Contact a service technician.	--
3. Product too stiff.	a. Consistency control knob needs adjusting.	a. Contact a service technician.	--
	b. Improper mixing of product.	b. Carefully follow directions for mixing product.	--
	c. Insufficient product in the freezing cylinder.	c. Keep hopper full of mix.	9
4. Scored walls of freezing cylinder.	a. Broken beater pins.	a. Repair or replace beater assembly.	--
	b. Gear unit out of alignment.	b. Contact a service technician.	--
	c. Bent beater assembly.	c. Repair or replace.	--
	d. Missing front bearing.	d. Replace or install front bearing.	10
5. Unable to remove drive shaft.	a. Lubrication on hex end of drive shaft.	a. Do not lubricate the hex end. Contact service technician for removal.	10
	b. Rounded corners of the drive shaft, drive coupling or both.	b. Replace drive shaft, drive coupling or both.	--
6. Excessive mix leakage in rear drip pan.	a. Improper or inadequate lubrication on drive shaft o-ring or seal on drive shaft.	a. Use an approved food grade lubricant (example: Taylor Lube) and follow lubrication procedures.	10
	b. Bad or missing o-ring or seal on drive shaft.	b. Replace rubber parts every 3 months.	19
	c. Worn rear shell bearing.	c. Contact a service technician for replacement.	--

PROBLEM	PROBABLE CAUSE	REMEDY	PAGE REF.
7. No freezer operation with unit in the "AUTO" position.	a. Unit unplugged.	a. Plug cord in wall receptacle.	--
	b. Beater motor has tripped the internal overload.	b. Place control switch in the "OFF" position. Allow the motor to cool, then resume normal operation. Contact a service technician if problem continues.	--
	c. Tripped circuit breaker or blown fuse.	c. Reset circuit breaker or replace blown fuse.	--
	d. The rod resting on top of the valve handle pin must be raised to activate refrigeration.	d. Raise and release the lever.	11
8. Unit not freezing product when in the "AUTO" position.	a. Refrigerant leak.	a. Call for service to repair leak.	--
	b. Dirty condensers.	b. Clean regularly.	15
9. Missing guide bearing.	a. Guide bearing stuck in drive shaft.	a. Remove guide bearing from hole in drive shaft.	--
10. Excessive leakage from the door spout.	a. Improper or inadequate lubrication on draw valve o-rings.	a. Use an approved food grade lubricant (example: Taylor Lube) and follow lubrication procedures.	10
	b. Bad or missing o-rings on draw valve.	b. Replace rubber parts every three months.	19
11. Door will not go into position easily.	a. Position of beater assembly.	a. The open end of the beater assembly should be in the 11 o'clock position.	11

Section 9 Parts Replacement Schedule

PART DESCRIPTION	EVERY 3 MONTHS	EVERY 6 MONTHS	ANNUALLY
Drive Shaft O- ring	X		
Drive Shaft Seal	X		
Scraper Blade	Inspect & Replace if Necessary	Minimum	
Baffle O- ring	X		
Guide Bearing	X		
Freezer Door Gasket	X		
Front Bearing	X		
Draw Valve O- ring	X		
Black Bristle Brush, 1" x 2"		Inspect & Replace if Necessary	Minimum
Double Ended Brush		Inspect & Replace if Necessary	Minimum
White Bristle Brush, 1" x 2"		Inspect & Replace if Necessary	Minimum
White Bristle Brush, 3" x 7"		Inspect & Replace if Necessary	Minimum

Refer to Parts List when ordering above parts.

Section 10 Limited Warranty on Equipment

TAYLOR COMPANY LIMITED WARRANTY ON FREEZERS

Taylor Company, a division of Carrier Commercial Refrigeration, Inc. ("Taylor") is pleased to provide this limited warranty on new Taylor-branded freezer equipment available from Taylor to the market generally (the "Product") to the original purchaser only.

LIMITED WARRANTY

Taylor warrants the Product against failure due to defect in materials or workmanship under normal use and service as follows. All warranty periods begin on the date of original Product installation. If a part fails due to defect during the applicable warranty period, Taylor, through an authorized Taylor distributor or service agency, will provide a new or re-manufactured part, at Taylor's option, to replace the failed defective part at no charge for the part. Except as otherwise stated herein, these are Taylor's exclusive obligations under this limited warranty for a Product failure. This limited warranty is subject to all provisions, conditions, limitations and exclusions listed below and on the reverse (if any) of this document.

Product	Part	Limited Warranty Period
Soft Serve	Insulated shell assembly	Five (5) years
Frozen Yogurt Shakes	Refrigeration compressor (except service valve)	Five (5) years
Smoothies	Beater motors	Two (2) years
Frozen Beverage	Beater drive gear	Two (2) years
Batch Desserts	Printed circuit boards and Softech controls beginning with serial number H8024200	Two (2) years
	Parts not otherwise listed in this table or excluded below	One (1) year

LIMITED WARRANTY CONDITIONS

1. If the date of original installation of the Product cannot be verified, then the limited warranty period begins ninety (90) days from the date of Product manufacture (as indicated by the Product serial number). Proof of purchase may be required at time of service.
2. This limited warranty is valid only if the Product is installed and all required service work on the Product is performed by an authorized Taylor distributor or service agency, and only if genuine, new Taylor parts are used.
3. Installation, use, care, and maintenance must be normal and in accordance with all instructions contained in the Taylor Operator's Manual.
4. Defective parts must be returned to the authorized Taylor distributor or service agency for credit.
5. The use of any refrigerant other than that specified on the Product's data label will void this limited warranty.

LIMITED WARRANTY EXCEPTIONS

This limited warranty does **not** cover:

1. Labor or other costs incurred for diagnosing, repairing, removing, installing, shipping, servicing or handling of defective parts, replacement parts, or new Products.
2. Normal maintenance, cleaning and lubrication as outlined in the Taylor Operator's Manual, including cleaning of condensers.

3. Replacement of wear items designated as Class "000" parts in the Taylor Operator's Manual.
4. External hoses, electrical power supplies, and machine grounding.
5. Parts not supplied or designated by Taylor, or damages resulting from their use.
6. Return trips or waiting time required because a service technician is prevented from beginning warranty service work promptly upon arrival.
7. Failure, damage or repairs due to faulty installation, misapplication, abuse, no or improper servicing, unauthorized alteration or improper operation or use as indicated in the Taylor Operator's Manual, including but not limited to the failure to use proper assembly and cleaning techniques, tools, or approved cleaning supplies.
8. Failure, damage or repairs due to theft, vandalism, wind, rain, flood, high water, water, lightning, earthquake or any other natural disaster, fire, corrosive environments, insect or rodent infestation, or other casualty, accident or condition beyond the reasonable control of Taylor; operation above or below the electrical or water supply specification of the Product; or components repaired or altered in any way so as, in the judgment of the Manufacturer, to adversely affect performance, or normal wear or deterioration.
9. Any Product purchased over the Internet.
10. Failure to start due to voltage conditions, blown fuses, open circuit breakers, or damages due to the inadequacy or interruption of electrical service.
11. Electricity or fuel costs, or increases in electricity or fuel costs from any reason whatsoever.
12. Damages resulting from the use of any refrigerant other than that specified on the Product's data label will void this limited warranty.
13. Any cost to replace, refill or dispose of refrigerant, including the cost of refrigerant.
14. **ANY SPECIAL, INDIRECT OR CONSEQUENTIAL PROPERTY OR COMMERCIAL DAMAGE OF ANY NATURE WHATSOEVER.** Some jurisdictions do not allow the exclusion of incidental or consequential damages, so this limitation may not apply to you.

This limited warranty gives you specific legal rights, and you may also have other rights which vary from jurisdiction to jurisdiction.

LIMITATION OF WARRANTY

THIS LIMITED WARRANTY IS EXCLUSIVE AND IS IN LIEU OF ALL OTHER WARRANTIES, CONDITIONS AND/OR REMEDIES UNDER THE LAW, INCLUDING ANY IMPLIED WARRANTIES OR CONDITIONS OF MERCHANTABILITY OR FITNESS FOR A PARTICULAR PURPOSE. THE ORIGINAL OWNER'S SOLE REMEDY WITH RESPECT TO ANY PRODUCTS SHALL BE REPAIR OR REPLACEMENT OF DEFECTIVE COMPONENTS UNDER THE TERMS OF THIS LIMITED WARRANTY. ALL RIGHTS TO CONSEQUENTIAL OR INCIDENTAL DAMAGES (INCLUDING CLAIMS FOR LOST SALES, LOST PROFITS, PRODUCT LOSS, PROPERTY DAMAGES OR SERVICE EXPENSES) ARE EXPRESSLY EXCLUDED. THE EXPRESS WARRANTIES MADE IN THIS LIMITED WARRANTY MAY NOT BE ALTERED, ENLARGED, OR CHANGED BY ANY DISTRIBUTOR, DEALER, OR OTHER PERSON, WHATSOEVER.

LEGAL REMEDIES

The owner **must** notify Taylor in writing, by certified or registered letter to the following address, of any defect or complaint with the Product, stating the defect or complaint and a specific request for repair, replacement, or other correction of the Product under warranty, mailed at least thirty (30) days before pursuing any legal rights or remedies.

Taylor Company
a division of Carrier Commercial Refrigeration, Inc.
750 N. Blackhawk Blvd.
Rockton, IL 61072, U.S.A.

Section 11

Limited Warranty on Parts

TAYLOR COMPANY LIMITED WARRANTY ON TAYLOR GENUINE PARTS

Taylor Company, a division of Carrier Commercial Refrigeration, Inc. ("Taylor") is pleased to provide this limited warranty on new Taylor genuine replacement components and parts available from Taylor to the market generally (the "Parts") to the original purchaser only.

LIMITED WARRANTY

Taylor warrants the Parts against failure due to defect in materials or workmanship under normal use and service as follows. All warranty periods begin on the date of original installation of the Part in the Taylor unit. If a Part fails due to defect during the applicable warranty period, Taylor, through an authorized Taylor distributor or service agency, will provide a new or re-manufactured Part, at Taylor's option, to replace the failed defective Part at no charge for the Part. Except as otherwise stated herein, these are Taylor's exclusive obligations under this limited warranty for a Part failure. This limited warranty is subject to all provisions, conditions, limitations and exclusions listed below and on the reverse (if any) of this document.

Part's Warranty Class Code or Part	Limited Warranty Period
Class 103 Parts ¹	Three (3) months
Class 212 Parts ²	Twelve (12) months
Class 512 Parts	Twelve (12) months
Class 000 Parts	No warranty
Taylor Part #072454 (Motor- 24VDC *C832/C842*)	Four (4) years

LIMITED WARRANTY CONDITIONS

1. If the date of original installation of the Part cannot be otherwise verified, proof of purchase may be required at time of service.
2. This limited warranty is valid only if the Part is installed and all required service work in connection with the Part is performed by an authorized Taylor distributor or service agency.
3. The limited warranty applies only to Parts remaining in use by their original owner at their original installation location in the unit of original installation.
4. Installation, use, care, and maintenance must be normal and in accordance with all instructions contained in the Taylor Operator's Manual.
5. Defective Parts must be returned to the authorized Taylor distributor or service agency for credit.
6. This warranty is not intended to shorten the length of any warranty coverage provided pursuant to a separate Taylor Limited Warranty on freezer or grill equipment.
7. The use of any refrigerant other than that specified for the unit in which the Part is installed will void this limited warranty.

^{1, 2} Except that Taylor Part #032129SER2 (Compressor-Air-230V SERV) and Taylor Part #075506SER1 (Compressor-Air-115V 60HZ) shall have a limited warranty period of twelve (12) months when used in Taylor freezer equipment and a limited warranty period of two (2) years when used in Taylor grill equipment.

LIMITED WARRANTY EXCEPTIONS

This limited warranty does **not** cover:

1. Labor or other costs incurred for diagnosing, repairing, removing, installing, shipping, servicing or handling of defective Parts, replacement Parts, or new Parts.
2. Normal maintenance, cleaning and lubrication as outlined in the Taylor Operator's Manual, including cleaning of condensers or carbon and grease buildup.
3. Required service, whether cleaning or general repairs, to return the cooking surface assemblies, including the upper platen and lower plate, to an operational condition to achieve proper cooking or allow proper assembly of release sheets and clips as a result of grease build-up on the cooking surfaces, including but not limited to the platen and plate, sides of the shroud or top of the shroud.
4. Replacement of cooking surfaces, including the upper platen and lower plate, due to pitting or corrosion (or in the case of the upper platen, due to loss of plating) as a result of damage due to the impact of spatulas or other small wares used during the cooking process or as a result of the use of cleaners, cleaning materials or cleaning processes not approved for use by Taylor.
5. Replacement of wear items designated as Class "000" Parts in the Taylor Operator's Manual, as well as any release sheets and clips for the Product's upper platen assembly.
6. External hoses, electrical power supplies, and machine grounding.
7. Parts not supplied or designated by Taylor, or damages resulting from their use.
8. Return trips or waiting time required because a service technician is prevented from beginning warranty service work promptly upon arrival.
9. Failure, damage or repairs due to faulty installation, misapplication, abuse, no or improper servicing, unauthorized alteration or improper operation or use as indicated in the Taylor Operator's Manual, including but not limited to the failure to use proper assembly and cleaning techniques, tools, or approved cleaning supplies.
10. Failure, damage or repairs due to theft, vandalism, wind, rain, flood, high water, water, lightning, earthquake or any other natural disaster, fire, corrosive environments, insect or rodent infestation, or other casualty, accident or condition beyond the reasonable control of Taylor; operation above or below the gas, electrical or water supply specification of the unit in which a part is installed; or Parts or the units in which they are installed repaired or altered in any way so as, in the judgment of Taylor, to adversely affect performance, or normal wear or deterioration.
11. Any Part purchased over the Internet.
12. Failure to start due to voltage conditions, blown fuses, open circuit breakers, or damages due to the inadequacy or interruption of electrical service.
13. Electricity, gas or other fuel costs, or increases in electricity or fuel costs from any reason whatsoever.
14. Damages resulting from the use of any refrigerant other than that specified for the unit in which the Part is installed will void this limited warranty.
15. Any cost to replace, refill or dispose of refrigerant, including the cost of refrigerant.
16. **ANY SPECIAL, INDIRECT OR CONSEQUENTIAL PROPERTY OR COMMERCIAL DAMAGE OF ANY NATURE WHATSOEVER.** Some jurisdictions do not allow the exclusion of incidental or consequential damages, so this limitation may not apply to you.

This limited warranty gives you specific legal rights, and you may also have other rights which vary from jurisdiction to jurisdiction.

LIMITATION OF WARRANTY

THIS LIMITED WARRANTY IS EXCLUSIVE AND IS IN LIEU OF ALL OTHER WARRANTIES, CONDITIONS AND/OR REMEDIES UNDER THE LAW, INCLUDING ANY IMPLIED WARRANTIES OR CONDITIONS OF MERCHANTABILITY OR FITNESS FOR A PARTICULAR PURPOSE. THE ORIGINAL OWNER'S SOLE REMEDY WITH RESPECT TO ANY PRODUCTS SHALL BE REPAIR OR REPLACEMENT OF DEFECTIVE PARTS UNDER THE TERMS OF THIS LIMITED WARRANTY. ALL RIGHTS TO CONSEQUENTIAL OR INCIDENTAL DAMAGES (INCLUDING CLAIMS FOR LOST SALES, LOST PROFITS, PRODUCT LOSS, PROPERTY DAMAGES OR SERVICE EXPENSES) ARE EXPRESSLY EXCLUDED. THE EXPRESS WARRANTIES MADE IN THIS LIMITED WARRANTY MAY NOT BE ALTERED, ENLARGED, OR CHANGED BY ANY DISTRIBUTOR, DEALER, OR OTHER PERSON, WHATSOEVER.

LEGAL REMEDIES

The owner **must** notify Taylor in writing, by certified or registered letter to the following address, of any defect or complaint with the Part, stating the defect or complaint and a specific request for repair, replacement, or other correction of the Part under warranty, mailed at least thirty (30) days before pursuing any legal rights or remedies.

Taylor Company
a division of Carrier Commercial Refrigeration, Inc.
750 N. Blackhawk Blvd.
Rockton, IL 61072, U.S.A.

Section 12

Parts List

Copeland Compressor - J8086700/Up (Update 134)

DESCRIPTION	PART NUMBER	QTY.	WARR. CLASS	REMARKS	PARTS UPDATE
ARM-BAFFLE *390*	047729	1	103		
BAFFLE ASSEMBLY	X47731	1	103		
+O-RING-.291 ID X .080W	018550	1	000		
BEARING-FRONT	013116	1	000		
BEARING-GUIDE	014496	1	000		
BEARING-REAR SHELL *PLASTIC*	032511	1	000		
+WASHER-BEARING LOCK	012864	1	000		
+O-RING-1-1/16 OD X .070 WALL	018432	1	000		
+NUT-BRASS BEARING	028991	1	000		
+GUIDE-DRIP SEAL	028992	1	000		
BEARING-UNIT-REAR 1 PULLEY				USE KIT A-REAR BEARING UNIT	
BEATER A-.7QT-1 PIN-SUPPORT	X46233	1	103		
+BLADE-SCRAPER-PLASTIC 9-13/16L	046237	2	000		
+CLIP-SCRAPER BLADE	046238	2	103		
BELT-POLY V-525J10	047728	1	000		
BLOCK-TERMINAL 2P	039422	1	103	208-230V 60HZ 1PH	
BLOCK-TERMINAL 3P L1	039423	1	103	208-230V 60HZ 3PH	
BRUSH-DOUBLE ENDED-PUMP&FEED T	013072	1	000		
BRUSH-DRAW VALVE 1"ODX2"X17"L	013073	1	000		
BRUSH-MIX PUMP BODY-3"X7"WHITE	023316	1	000		
BRUSH-REAR BRG 1IN.DX2IN.LGX14	013071	1	000		
BUSHING-SNAP 11/16 ID X 7/8 OD	010548	1	000		
BUSHING-PANEL	013289	2	103	S/N M1097205 & UP	
+SCREW-8X3/8 SAW SLOT PAN	013234	2	000	S/N M1097205 & UP	
COMPRESSOR L63B562BBCB	048727-27E	1	512	K6051964 & UP - BRISTOL - 208-230V 60HZ 1PH	
+CAPACITOR-RUN 30UF/370V	038487	1	103		
+CAPACITOR-START 161-193UF	031790	1	103		
+RELAY-START-COMPRESSOR	047067	1	103		
+GROMMET-COMPRESSOR MOUNTING	037428	4	000		
+SLEEVE-MOUNTING-COMP.	039924	4	000		
COMPRESSOR L63B562DBLB	048727-33E	1	512	K6051964 & UP - BRISTOL - 208-230V 60HZ 3PH	

+ Available Separately

DESCRIPTION	PART NUMBER	QTY.	WARR. CLASS	REMARKS	PARTS UPDATE
COMPRESSOR-RS80C1E-CAV	051958-27	1	512	J8086700-K6036687-COPELAND-208-230V 60HZ 1PH	
+CAPACITOR-RUN	012906	1	103		
+CAPACITOR-START	033044-1	1	103		
+RELAY-START-COMPRESSOR	051957-27	1	103		
COMPRESSOR-RS80C1E-TF5-224	051958-33	1	512	J8086700-K6036687-COPELAND-208-230V 60HZ 3PH	
COMPRESSOR-M50B103BBCB (OLD)	047065-	1	512	J8086700 & PRIOR - BRISTOL 208-230V 60HZ 1PH	
+CAPACITOR-RUN- 15UF/370V	047070	1	103		
+CAPACITOR-START-124-149UF/250V	047069	1	103		
+RELAY-START-COMPRESSOR	047067	1	103		
COMPRESSOR-L51B562DBLB (OLD)	048343-33	1	512	J8086700 & PRIOR - BRISTOL 208-230V 60HZ 3PH	
CONDENSER-AC-15LX14HX2.59T-3RW	046558	1	103		
COUPLING A.-TORQUE-SHAKE-HEX	X48316	1	103	HARD SLUSH OPTION USE X47000 COUPLING A.-TORQUE SHAKE	
COUPLING-TORQUE-DRIVE	046866	1	103		
COUPLING-TORQUE-LOAD-HEX	039397	1	103		
PIN-COUPLING-TORQUE	039453	3	103		
SCREW-5/16-18 X 3/8 ALLEN SET	025376	2	000		
SCREW-SHOULDER 3/16D X 1/2L-SS	039455	3	000		
SPRING-3/8 ODX3/16 IDXIL-BLUE	039987	3	103		
COVER A.-HOPPER-STD	X38458-SER	1	103		
+KNOB-MIX COVER	025429	1	103		
DECAL-CLEAN INST.-HOPPER	019029	1	000		
DECAL-DEC-TAYLOR-380	045452	1	000		
DECAL-TROUBLESHOOTING	038374	1	000		
DECAL-WASH-OFF-AUTO	014502	1	000		
DEFLECTOR-AIR	048549	1	103		
DIAGRAM-WIRING *390*	047730-27	1	000	208-230V 60HZ 1PH	
DIAGRAM-WIRING *390*	047730-33	1	000	208-230V 60HZ 3PH	
DOOR A.-PARTIAL *340-350-450*	X39248-SER	1	103		
+BUSTER-ICE *390*	047735	1	103		
+GASKET-DOOR 5.177ID X 5.938OD	016672	1	000	REPLACED 014030 ON 3/15/2011	
+HANDLE A.-DRAW-SLUSH-BLACK	X47384	1	103		
+O-RING-1"OD X .139W	032504	2	000	DRAW VALVE	

+ Available Separately

DESCRIPTION	PART NUMBER	QTY.	WARR. CLASS	REMARKS	PARTS UPDATE
+PIN A.-VALVE HANDLE	X25929	1	103		
+VALVE-DRAW *390*	047734	1	103		
DRYER-FILTER 3/8 X 1/4 SOLDER	048901	1	000		
FORM-QUALITY REPORT BY FAX	065712	1	000		
GASKET-HOPPER COVER-20 QT-SGL	038375	1	000		
GUIDE A.-DRIP PAN *340*341*390	X47190	1	103		
HARNES-WIRE MAIN CTRL*39	063734-27G	1	103	208-230V 60HZ 1PH	
HARNES-WIRE-MAIN CTRL*39	063002-33G	1	103	208-230V 60HZ 3PH	
KIT A.-REAR BEARING UNIT	X39162-SER	1	103	INCLUDES RETAINING PLATE	129
KIT A.-TUNE UP	X39969	1	000		
BEARING-FRONT	013116	1	000		
BEARING-GUIDE	014496	1	000		
+GASKET-DOOR 5.177ID X 5.938OD	016672	1	000	REPLACED 014030 ON 3/15/2011	
O-RING-.291 ID X .080W	018550	1	000	BAFFLE ASSEMBLY	
O-RING-7/8 OD X .139W	025307	1	000	DRIVE SHAFT	
O-RING-1"OD X .139W	032504	2	000	DRAW VALVE	
SEAL-DRIVE SHAFT	032560	1	000	DRIVE SHAFT	
TOOL-O-RING REMOVAL	048260-WHT	1	000		
LABEL-DOOR-WARN-MOVE PARTS	032749	1	000		
LABEL-WARN-COVER	051433	5	000		
LABEL-3PH MTR PROT/1PH C-	025949	1	000	208-230V 60HZ 3PH - 3 WIRE	
LEG-4" SS-W/ORING	013458	4	103		
LIGHT-ADD MIX-AMBER-RECTANGULR	047141-27	1	103		
LIGHT-MIX OUT-AMBER-RECTANGULAR	050036-27	1	103	S/N J8086700 AND UP REPLACES 047142-27	135
LINE A.-LIQUID *390*	X47012	1	103	CAPILLARY TUBE-HOPPER	
LUBRICANT-SUPER TAYLOR	047518	1	000		
MAN-OPER 390	048693-M	1	000		
MOTOR-1/2 HP	059742-27	1	212	S/N K603 & UP - REPLACES 024839-27	
MOTOR-FAN 80W 208/230V 60HZ	051744-27	1	212		
+FAN-5 BLADE 12" PUSH	047279	1	212		
+CAPACITOR-RUN	051785	1	103		
+BOOT-CAPACITOR	031314	1	000		
NUT-STUD *340-342-344-350-450*	029880	4	103	HANDSCREWS	

+ Available Separately

DESCRIPTION	PART NUMBER	QTY.	WARR. CLASS	REMARKS	PARTS UPDATE
PAIL-6 QT.	023348	1	000		
PAN-DRIP 19-1/2 LONG	035034	1	103		
PANEL A.-FRONT *390*	X47004	1	103		
PANEL-SIDE *390* RIGHT	068924	1	103	S/N M1097205 & UP	
PANEL-SIDE-LEFT *390*	068906	1	103	S/N M1097205 & UP	
PANEL-REAR *390*	047008	1	103		
+BUSHING-PANEL	013289	2	000		
+SCREW-8 X 3/8 RD HD TYP B	013234	2	000		
+SCREW-1/4-20X3/8 RHM-STNLS	011694	3	000		
+WASHER-PLASTIC PIVOT	013808	2	000		
PCB A.-CTRL *490/390* EVC2	X51393-SER	1	212		
CHIP-SOFTWARE - REV 1.01	X40869-SER	1	103		
PCB A.-EVC2	X50645-SER	1	212		
PCB A.-DUAL MIX LVL/CONT. FILL	X41420-SER	1	103		
PLATE-DEC-340-341	043456	1	103		
PROBE A.-MIX LOW-HT	X42077				
+DISC-PROBE *SQ HOLE*	030965	1	103		
+SPACER-PROBE *SQ HOLE*	030966	1	103		
PROBE A.-MIX OUT-SQUARE HOLE	X41348	1	103		
+O-RING-1/2OD X .070W	024278	2	000		
+SPACER-PROBE-SQUARE HOLE-7/8	041346	1	103		
+SPACER-PROBE-ROUND HOLE-5/8DIA	041347	1	103		
PULLEY-10J-12"PD-5/8BORE	025480	1	103	BEARING UNIT	
PULLEY-10J- 1.125PD-5/8BORE	028857	1	103	BTR MOTOR	
RELAY-3 POLE-20A-208/240 50/60	066795-33	1	103	REPLACES 012725-33	
RELAY-DPDT-20 A-24VAC	026581-03	1	103	208-230V 60HZ 3PH	
SANITIZER KAY-5 CASE 125 PKTS	041082	1	000		
SENSOR A.-EVC-SLUSH-15" *	X66231M			S/N K8026108 & UP	
SENSOR A.-EVC-SLUSH-15"	X44354	1	103	S/N K8026107 & PRIOR	
+BRACKET-SWITCH-PROXIMITY-LEFT	039648	1	103		
SHAFT-BEATER	036412	1	103		
+O-RING-7/8 OD X .139W	025307	1	000		
+SEAL-DRIVE SHAFT	032560	1	000		

+ Available Separately

DESCRIPTION	PART NUMBER	QTY.	WARR. CLASS	REMARKS	PARTS UPDATE
SHELL A.-INSULATED *390/490*	X68900-SER	1	512	S/N M1097205 & UP	
STUD-NOSE CONE-5/16-18X5/16-18	013496	1	103		
SHIELD-SPLASH-WIRE 13-11/16L	046177	1	103		
SHROUD-FAN *340/390*	052472	1	103		
SWITCH A.-DRAW *340*EVC	X44223-SER	1	103		
ARM A.-DRAW VALVE *340*EVC	X44224	1	103		
BRACKET A.-SWITCH *321-751*	X43722	1	103		
E-RING	049178	1	000		
PIN-PIVOT	015478	1	103		
SPRING-RETURN R.	023488	1	103		
SWITCH-LEVER-SPDT-10A-125-25	028889	1	103		
NUT-4-40 HEX-SS	038623	2	000		
SCREW-4-40X5/8 SLTD ROUND	027219	2	000		
WASHER-#4 EXTERNAL TOOTH LOC	043075	2	000		
SWITCH-PRESSURE 440 PSI--SOLDER	048230	1	103	K6051964 & UP - BRISTOL - 208-230V 60HZ 3PH	
SWITCH-PRESSURE 405 PSI-SOLDER	052663	1	103	J8086700, K6036687-COPELAND-208-230V 60HZ 1PH	
SWITCH-TOGGLE-DPDT*ON-OFF-ON	014464	1	103		
TRANS.-240V PR1/24V SEC 10 VA	030132-27	1	103		
TRAY-DRIP 14.8	046275	1	103		
TRIM-CORNER *390*LEFT	047002	1	103		
TRIM-CORNER *390*RIGHT	047003	1	103		
TRIM-FRONT *390*	050913	1	103		
TUBE-FEED-3/8 HOLE	015176-9	1	103		
VALVE-ACCESS 1/4FL X 1/4SOLDER	044404	1	103	EPR	
VALVE-ACCESS-1/4MFL X 3/8	053565	2	103	DISCHARGE LINE/HEAT EXCHANGER	
VALVE-EPR 1/4S	022665	1	103		
VALVE-EXP-AUTO-1/4S X1/4 FPT	046365	1	103		
+ BOOT-EXPANSION VALVE	050900	1	000		

+ Available Separately

DESCRIPTION	PART NUMBER	QTY.	WARR. CLASS	REMARKS	PARTS UPDATE
WATER COOLED					
ACCUMULATOR-COPPER 2"DIA 10"	047062	1	103		
BRACKET-FAN *453/750*	038641	1	103		
BRACKET-VALVE-WATER MOUNT	038777	1	103		
CLAMP-HOSE-ADJ 7/16 X 25/32	010031	6	000		
CONDENSER-WC-SPIRAL 11-1/2 OD	049309	1	103		
COUPLING-3/8 NPT BLACK PIPE	010878	1	103		
FAN-5 BLADE 7 " PUSH 30DEG	016289	1	103		
HOSE-RUBBER 1/2 ID X 7/8 OD	R50200	5'	000		
MOTOR-FAN 9 WATT 150RPM-CW	012768-27	1	103		
SWITCH-PRESSURE 350 PSI-SOLDER	048231	1	103		
VALVE-ACCESS-1/4 MFLX1/4 S-90	047016	1	103		
VALVE-ACCESS-1/4MFL X 3/8ODS	053565	1	103		
VALVE-WATER 3/8 REG/HEAD PRESS	046686	1	103		
50 HZ - 220-240V 50HZ 1PH					
BELT-POLY V-510J10	047049	1	000	K6051964 & UP - BRISTOL - 208-230V 60HZ 3PH	
BLOCK-TERMINAL 2P L1,N	039421				
BLOCK-TERMINAL 7P GREEN	024156				
COMPRESSOR L63B562BBKB	048727-40E	1	512		
+CAPACITOR-RUN 15UF/370V	027087	1			
+CAPACITOR-START 161-193UF	031790	1			
+RELAY-START-COMPRESSOR	048766	1			
DIAGRAM-WIRING *490*	047730-40	1	000		
FUSE-1 AMP-BUSS GLR 1	050449				
+HOLDER-FUSE-IN LINE-TYPE	045606				
MOTOR-1/2 HP	059742-40	1	103		
MOTOR-FAN 100W 220-240V 5	047178-34	1			
+CAPACITOR-RUN 4UF/370V	019624	1			
PULLEY-10J- 1.25PD-5/8BORE	033141	1	103		
PULLEY-10J-11"PD-5/8BORE	025570	1	103		
COMPRESSOR RS80C1E-CAZ-224	051958-40	1	512	J8086700 - K6036687 - COPELAND - 208-230V 60HZ 1PH	

+ Available Separately

DESCRIPTION	PART NUMBER	QTY.	WARR. CLASS	REMARKS	PARTS UPDATE
+ CAPACITOR-RUN	023606	1	103		
+ CAPACITOR-START	051960	1	103		
+ RELAY-COMPRESSOR START	051957-40	1	103		
MOTOR-FAN 100W 220-240 50HZ	047178-34	1	103		
+ CAPACITOR-RUN	019624	1	103		
+ BOOT-RUN CAPACITOR	031314	1	000		
PULLEY 10J - 1.25PD-5/8 BORE	033141	1	103	BEATER MOTOR	
PANEL MOUNT SPINNER OPTION					
EXTENSION-SPINNER DISC 1"	013483	1	103		
SPINNER A.-PANEL W/FILTER	X48375-27	1	103		
PANEL A.-FRONT	X47004-SP	1	103	PANEL W/HOLES FOR SPINNER MOUNT	
COSTCO - W/PRIME PLUG					
CAP-RESTRICTOR - 5/8 ID	053100	3	000	FOR DOOR SPOUT - 3 SHIPPED W/ACCESSORIES	140
DOOR A.-FREEZER	X50991-SER	1	103		
+BUSTER-ICE	047735	1	103		
+HANDLE A.-DRAW	X47384	1	103		
+PIN A.-VALVE HANDLE	X25929	1	103		
+PLUG-PRIME	050405	1	103	STAINLESS	
+O-RING-PRIME PLUG	043758	1	000		
+ VALVE-DRAW	047734	1	103		
+O-RING-DRAW VALVE	032504	2	000		
KIT A.-TUNE UP	X50413	1	000	WITHOUT BLADES	
BEARING-FRONT	013116	1	000		
GASKET-DOOR	014030	1	000		
BEARING-GUIDE	014496	1	000		
O-RING .291 ID X .080W	018550	1	000	BAFFLE ASSEMBLY	
O-RING-7/8 OD X .139W	025307	1	000	DRIVE SHAFT	
O-RING-1" OD X .139W	032504	2	000	DRAW VALVE	
SEAL-DRIVE SHAFT	032560	1	000	DRIVE SHAFT	
O-RING-.563 OD X .070W	043758	1	000	PRIME PLUG	

+ Available Separately

DESCRIPTION	PART NUMBER	QTY.	WARR. CLASS	REMARKS	PARTS UPDATE
TOOL-O-RING REMOVAL	048260-WHT	1	000		
KIT A.-TUNE UP*390*COSTCO	X62226	1	000	WITH BLADES - OPTIONAL	
BEARING-FRONT	013116	1	000		
GASKET-DOOR	014030	1	000		
BEARING-GUIDE	014496	1	000		
BLADE-SCRAPER-PLASTIC	046237	2	000		
O-RING .291 ID X .080W	018550	1	000	BAFFLE ASSEMBLY	
O-RING-7/8 OD X .139W	025307	1	000	DRIVE SHAFT	
O-RING-1" OD X .139W	032504	2	000	DRAW VALVE	
SEAL-DRIVE SHAFT	032560	1	000	DRIVE SHAFT	
O-RING-.563 OD X .070W	043758	1	000	PRIME PLUG	
TOOL-O-RING REMOVAL	048260-WHT	1	000		
TUBE-FEED 3/8 HOLE	053062-SP9	1	103		
PANEL SPINNER					
EXTENSION-SPINNER DISC 1"	013483	1	103		
PANEL A.-FRONT *390* SPIN	X47004-SP	1	103		
SPINNER A.-PANEL W/FILTER	X48375-27	1	103		
HARD SLUSH					
BAFFLE A. *390* HARD SLUSH	X69384	1	103	6/6/2011	
COUPLING A.-TORQUE-SHAKE-	X47000	1	103		
PIN-STOP-TORQUE COUPLING-	042312	3	103		
SPRING-3/8 ODX3/16 IDX1L-	039454	3	103		

+ Available Separately

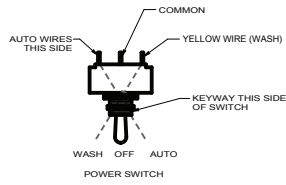

COPELAND MODEL RS80 COMPRESSOR IS CONFIGURED WITH AN EXTERNAL OVERLOAD AS FOLLOWS:

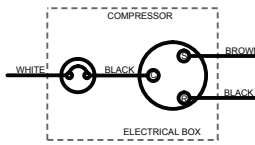

GROUND FRAME SECURELY

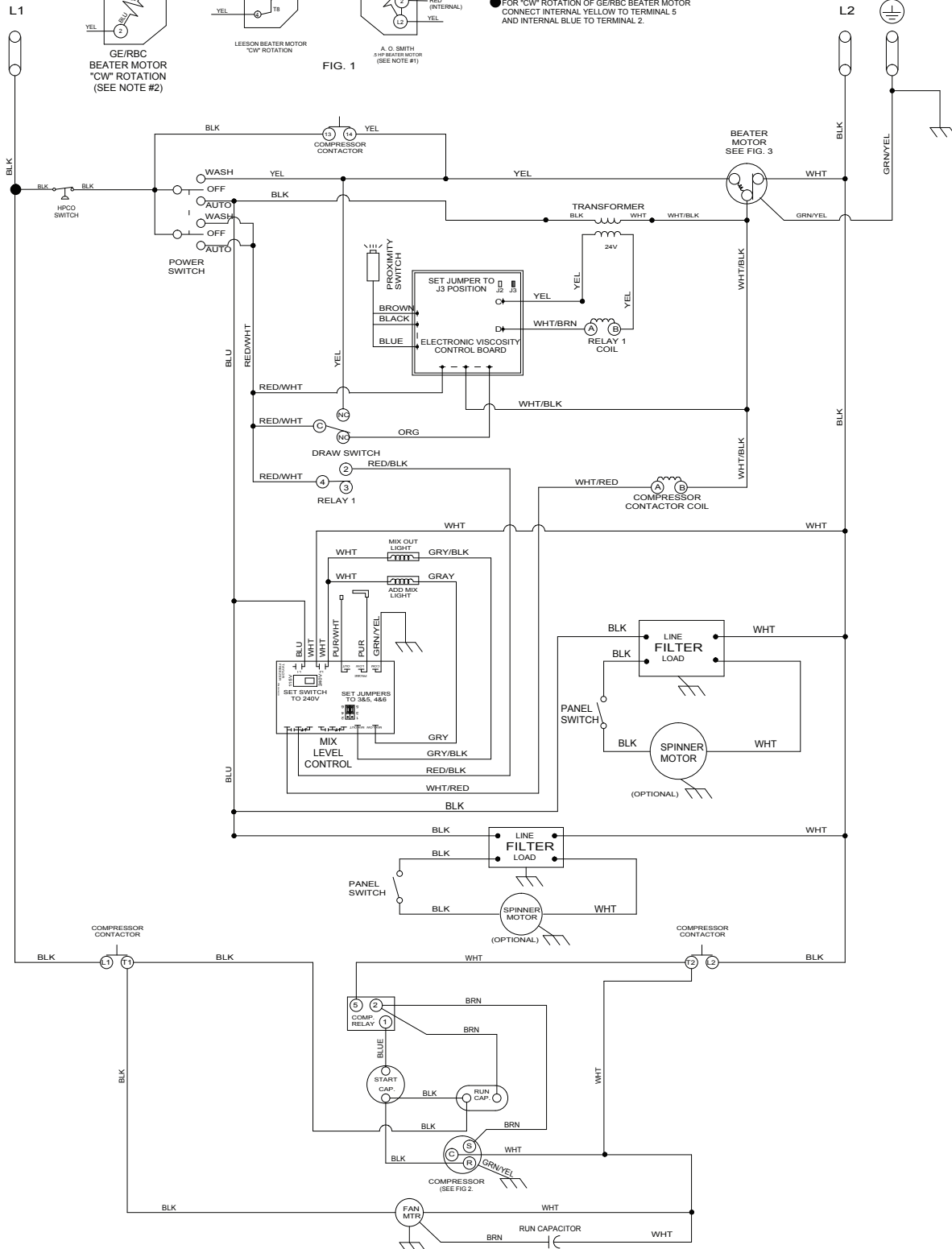
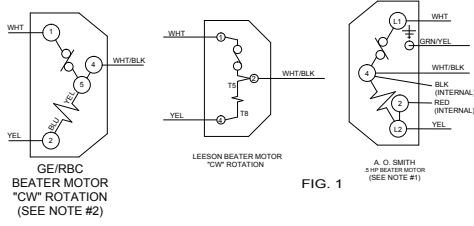

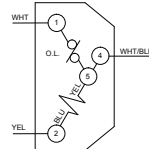
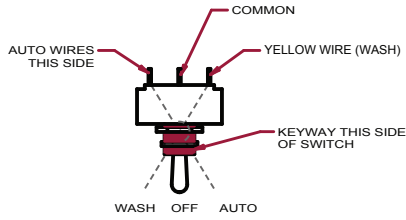

GE/RBC
BEATER MOTOR
"CW" ROTATION
(SEE NOTE #1)

FIG. 1

NOTE:
● FOR "CW" ROTATION OF GE/RBC BEATER MOTOR
CONNECT INTERNAL YELLOW TO TERMINAL 5
AND INTERNAL BLUE TO TERMINAL 2.

GROUND FRAME SECURELY
COMPRESSOR & BEATER MOTOR PROTECTED
UNDER PRIMARY SINGLE PHASING CONDITIONS

