

TAU-500

POWER AMPLIFIER

**NEW
ADVENTURES
IN
BROADCASTING**

Technalogix

You've already unpacked it, haven't you? You've unpacked it and plugged it in and turned it on and fiddled with the knobs. No? Okay, good. Please take a few minutes to read the manual and familiarize yourself with your new Technalogix power amplifier.

We believe that this manual, and of course our equipment, should be everything you need to get on the air with superb broadcast quality video. We understand that a capable and confident user will get the most out of our product and we have made every attempt to educate readers of all technical levels. If there is something that is not clear, or you require further information, please do not hesitate to contact us and we'll be glad to help out.

Technalogix Ltd.
#4, 8021 Edgar Industrial Place
Red Deer, Alberta, Canada
T4P 3R3
Phone: 403.347.5400
Fax: 403.347.7444
URL: www.technalogix.ca
Email: technical@technalogix.ca
sales@technalogix.ca

We truly appreciate that you have chosen us as your television broadcast system supplier. Happy viewing.

Table of Contents

SECTION I- SAFEGUARDS	I-1
SAFETY AND FIRST AID.....	I-2
OPERATING SAFEGUARDS	I-3
SECTION II - WARRANTY	II-1
SECTION III - OVERVIEW	III-1
STANDARD FEATURES	III-1
PRINCIPLE OF OPERATION.....	III-2
BLOCK DIAGRAM.....	III-3
SPECIFICATIONS.....	III-5
SECTION IV - RF COMPONENTS	IV-1
AMPLIFIER PALLETS	IV-1
SPLITTER/COMBINER.....	IV-4
DIRECTIONAL COUPLER.....	IV-4
ISOLATOR	IV-4
FILTER.....	IV-4
SECTION V - POWER SUPPLY SECTION	V-1
SECTION VI - MONITOR AND CONTROL SYSTEM	VI-1
CONTROL BOARD OVERVIEW (SERIES II-I).....	VI-1
POWER SUPPLY COMPONENTS	VI-1
INTERFACE COMPONENTS	VI-2
SIGNAL CONDITIONING COMPONENTS	VI-3
DISPLAY COMPONENTS	VI-4
MICROCONTROLLER COMPONENTS.....	VI-5
FAULT SHUTDOWN.....	VI-6
REMOTE PORT.....	VI-7
BILL OF MATERIALS	VI-8
SCHEMATICS	VI-10
SECTION VII - MECHANICAL SECTION	VII-1

SECTION VIII - INSTALLATION	VIII-1
BUILDING RECOMMENDATIONS.....	VIII-1
HEATING AND COOLING REQUIREMENTS	VIII-2
ELECTRICAL SERVICE RECOMMENDATIONS.....	VIII-3
ANTENNA AND TOWER RECOMMENDATIONS.....	VIII-4
SHELTER SECURITY	VIII-5
UNPACKING AND INSPECTION.....	VIII-6
LOCATION AND FUNCTION OF CONTROLS AND CONNECTORS (TAU-500 POWER AMPLIFIERS).....	VIII-7
LOCATION AND FUNCTION OF CONTROLS AND CONNECTORS (POWER SUPPLY).....	VIII-9
INITIAL HOOK UP.....	VIII-11
SECTION IX - OPERATING PROCEDURE	IX-1
SECTION X - MAINTENANCE AND TROUBLESHOOTING	X-1
TROUBLESHOOTING	X-2

Section I - Safeguards

General Safeguards

This section is written as a general guide to keep all 5 fingers on your hand and is intended for those having previous knowledge and experience with these kinds of equipment. It is not intended to contain a complete statement of all safety precautions, which should be observed by personnel using this or other electronic equipment.



DOCUMENTATION - Read, retain and follow instructions before operating the equipment. There is a lot of useful information in the manual, and besides, we spent a lot of time writing it!



ENVIRONMENT - To reduce the risk of fire or electric shock, do not expose this equipment to rain, moisture, or rye and sodas at the company Christmas party. Refer all servicing to qualified service personnel.



SERVICING - Do not attempt to service this equipment yourself as opening or removing covers can result in a warm tingly feeling and will void the warranty. Refer all servicing to qualified service personnel.

Safety and First Aid

Personnel engaged in the installation, operation, maintenance, or servicing of electronic equipment are exposed to the hazard of high voltage. It is imperative that all safety regulations and precautions are consistently observed. Knowledge of first aid procedures is recommended. The following information is presented as a reference only.

- At all times, avoid placing any part of the body in series between ground and circuit points, whether power is on or off.
- Dangerous voltage may be present in equipment even though power is off. Do not open the cabinet. Refer servicing to qualified service personnel.
- It is the duty of all personnel to be prepared to give adequate emergency first aid treatment and thereby prevent avoidable loss of life.
- There are three principle degrees of burns, recognizable as follows:
 - a first-degree burn reddens the skin.
 - a second-degree burn blisters the skin.
 - a third degree burn chars the flesh and frequently places the victim in a state of shock accompanied by respiratory paralysis.
- Respiratory paralysis can cause death by suffocation within seconds. It is imperative that the approved methods of artificial respiration are initiated immediately and continue until the victim's breathing is normal.
- A muscular spasm of unconsciousness may render the victim unable to break free of the electric power. If this is the case, turn the power off immediately.

DO NOT TOUCH THE VICTIM OR YOU MAY SHARE THE SAME PREDICAMENT.

- If the power cannot be turned off immediately, very carefully loop a dry rope, article of clothing, length of strong cloth or a rolled-up newspaper around the victim and pull the victim free of the power source. Carefully avoid touching the victim or clothing.
- Once free of the power source, the victim must be placed in a reclining position and covered with a blanket or newspapers to keep warm. At the first opportunity, enlist help in summoning a doctor. If a doctor cannot be summoned, transport the victim to the doctor or a hospital. Be sure the victim is kept well covered and warm while awaiting professional treatment.

Operating Safeguards

It is a known fact that our broadcast transmitters and translators enjoy 50-ohm load impedances. So much so, that it is imperative you maintain 50-ohm impedances throughout your system. In return, your equipment will provide you with maximum power transfer to the antenna and decreased reflected power heading back towards the amplifier pallets, reducing the amount of magic smoke that gets let out of the power amplifier. Before anything is turned on, ensure that there is a 50-ohm path from the output of each stage to the input of the next, all the way to the antenna.

In addition to maintaining proper 50-ohm impedances throughout the signal chain, it is also important, whenever possible, to make sure the RF drive going to the input of the power amplifier is removed before turning on or turning off the DC power supply. This is because all of the RF transistors used in the individual amplifier pallets are fabricated with LDMOS (Laterally Diffused Metal Oxide Semiconductor) technology. Nice and linear yes, but they do not like to make any RF power when their supply voltages are not within a specific range. When you first turn your power amplifier on or off, the DC power supply's output voltage may take a while to stable out to a safe operating voltage. Ten seconds wait before applying the RF drive will ensure no issues arise.

Our power amplifiers are designed to reliably generate a specific RF output power. Failing to adhere to overdriven amplifier warnings can decrease the reliability of your system, and frankly, makes our repair department busy and grumpy. If you need to transmit to a little larger coverage, you are better off increasing antenna gain, and more importantly, antenna height above average terrain. On TV and FM broadcast frequencies, insufficient antenna height puts an upper limit on your range, regardless of power levels, as the distance from your antenna to the radio horizon is limited.

Section II - Warranty

Our legalese is straightforward. It is simply designed to give you peace of mind and helps you resist the temptation to have your electronics friend try to repair your Technalogix product.

Technalogix Ltd. products have been completely tested and found to meet specifications and be in proper operating condition. They are warranted to be free from defects in materials and workmanship for a period of one year from the date of shipment. If the system becomes damaged in shipment and there are obvious signs of damage to the outside of the packaging, notify your courier immediately before that courier walks out the door.

Technalogix Ltd. will not be liable for damages of whatever nature arising out of or in connection with the equipment or its use thereof. Technalogix does not assume responsibility for injury or damage resulting from the practices of untrained or unqualified personnel in the handling of this equipment.

Technalogix Ltd. warranty does not include:

- misuse, neglect or accident.
- incorrect wiring and /or improper installation.
- unauthorized repairs, modifications or use in violation of instructions issued by Technalogix.
- incidental or consequential damages as a result of any defect.
- reshipment cost or insurance of the unit or replacement units or parts.
- acts of nature or terrorism.

Technalogix agrees, at our option, to remedy warranted defects or furnish a new part in exchange for any part of a unit which, under normal installation, use and service, becomes defective. The user will pay for transportation costs to and from the repair center. If you require technical service on the site, the cost to you will be \$800.00 per day plus air fare and meals.

To claim your rights under this warranty:

- Contact Technalogix and describe the problem in as much detail as possible. See troubleshooting section in this manual. If a solution cannot be found at this time, it may be determined that the unit will have to be returned to Technalogix for repair, once a Return Materials Authorization (RMA) number is provided. Please look under our web site (www.technalogix.ca) for the RMA form (Service) and fill it out. Either fax it to us or email to us.
- Package equipment carefully for prepaid shipment to Technalogix. Include a written description of the problem experienced, a copy of the original invoice establishing warranty status, and the RMA.

Technalogix reserves the right to make revisions in current production of the equipment and assumes no obligation to incorporate these changes in earlier models.

Shipping Address:

Technalogix Ltd.
ATTN: RMA# _____
#4, 8021 Edgar Industrial Place
Red Deer, Alberta, Canada
T4P 3R3
Ph: 403.347.5400
Made in Canada, returned for repairs

Section III – Overview

Standard Features

- Narrow output bandpass filter allows adjacent channel operation
- Front panel Liquid Crystal Display (LCD) to monitor forward and reflected RF power, and DC voltage
- Microcontroller-based monitoring and control ensures amplifier will never be overdriven and high VSWR will not damage amplifier
- AC circuit breaker on back panel to eliminate replacement of fuses
- All aluminium enclosure maintains power amplifier's light weight
- Simple design using commonly available parts ensures reliable operation
- Predominate and third-order intermodulation distortion exceeds Industry Canada and FCC specification.

Principle of Operation

The TAU-500 power amplifier supplies a 500-watt peak video signal with an aural carrier level 10 to 13 dB below visual carrier (dBc) on any of the UHF television channels 14 through 69. Please note that channel selection must be made at time of order, as the transmitter or translator is calibrated and tested to the channel requested and is not field tuneable. The TAU-500 power amplifier is a modular solid-state 500-watt broadcast amplifier utilizing readily available RF components wherever possible, thus enhancing the serviceability of the equipment.

The TAU-500 is comprised of a TECH-30U driver pallet and (2) P300 final pallets that are combined to create 500 watts of peak visual power in addition to the aural carrier power.

The TAU-500 features ultra linear amplification and individual channel RF output bandpass filtering. The amplifier modules are stable for high reliability and long service life.

Block Diagram

The RF signal enters through the RF Input connector on the power amplifier enclosure from the modulator or processor. It then passes through an RF attenuator to limit the output power level of the power amplifier and to help buffer any transients that may come into the power amplifier. After attenuation, the signal gets preamplified through the driver pallet before the signal gets split into (2) signals for final amplification. The output of the (2) final amplifier pallets get combined and passes through an isolator and a bandpass filter. Finally, the signal passes through a dual directional coupler for monitoring purposes before heading out to an antenna for broadcast.

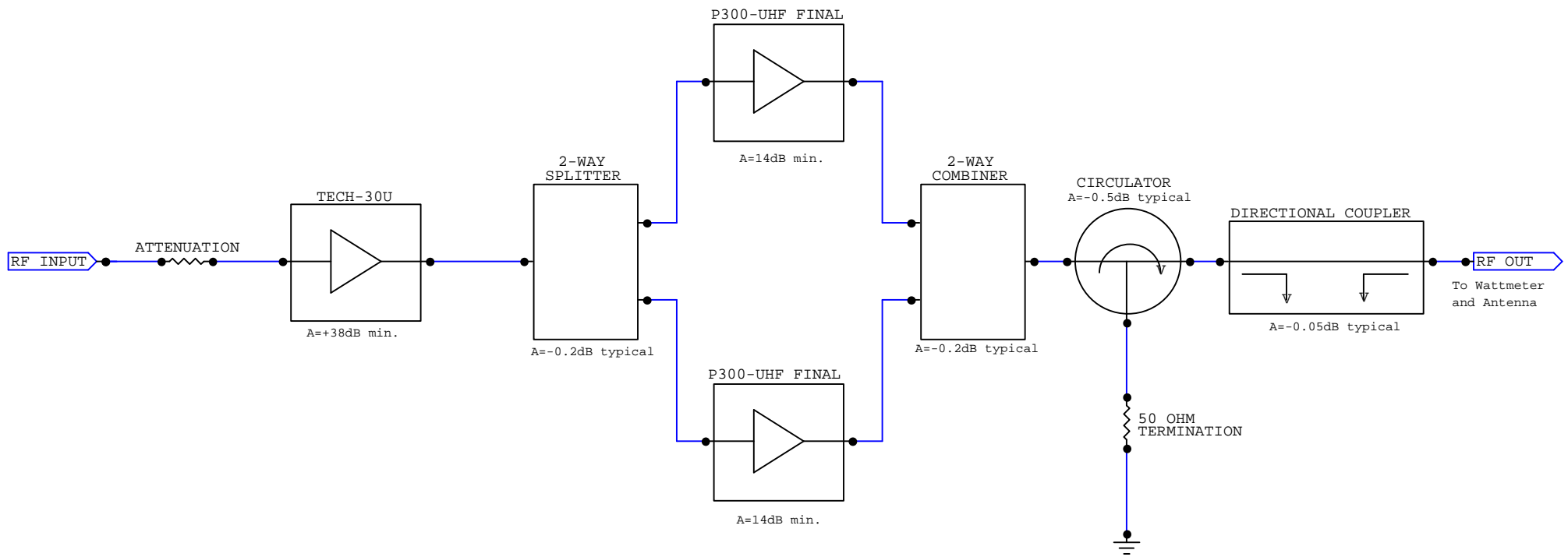

TAU-500 Block Diagram	
Rev	ID
Date: May 24, 2005	Page: 1 of 1

Specifications

The following specifications were taken with a Technalogix modulator/processor. Should a different modulator or processor be used, specifications could vary. For this reason, we recommend that any different modulator/processor be shipped to Technalogix so the system can be matched and set up optimally. In addition, the audio/video ratio the input to the power amplifier needs to be -10 dB in order for the software and LCD readout to be accurate.

RF Characteristics

Frequency range	any specified UHF Channel 14 to 60**	
Frequency Response (one channel)	±0.5 dB	
Frequency Stability	±250 Hz	
Selectivity	60 dB (adjacent channel)	
Minimum Input Level	0 dBmV	
Rated Visual Output Power	500 Watts	
Rated Aural Output Power	10% of peak visual power	
IF Output Level	+35 dBmV nominal	
Input Impedance	75 Ohms	
Output Impedance	50 Ohms	
Harmonics	> 60 dB below rated power	
Predominant Intermodulation Distortion	dBc = decibels below visual carrier	
	+ 920 kHz	> -53 dBc
	- 920 kHz	> -53 dBc
	+ 2.66 MHz	> -53 dBc
	- 2.66 MHz	> -53 dBc
	+ 5.42 MHz	> -53 dBc
	+ 7.16 MHz	> -53 dBc
3 rd Order Intermodulation Distortion		
	+ 4.5 MHz	> -60 dBc
	+ 9.0 MHz	> -60 dBc
	All others	> -60 dBc
Spurious Emissions		> -60 dBc

** Stand-alone power amplifier will operate from channels 14-69.

PAL Video Characteristics

Input Level to modulator (for 87.5% modulation)	1.0 V _{PP}
Differential Phase (at 87.5% modulation)	±2 Degrees
Differential Gain (at 87.5% modulation)	2%
Group Delay	< ±40 nS
Video Group Delay Pre-emphasis	Conforms to IC/FCC specifications
K-Factor	1.9% for 2T Pulse
Hum and Noise	> 60 dB below rated power

Aural Characteristics

Input Level for 25 kHz Deviation	0.3 V _{PP}
Frequency Response (Standard Pre-emphasis)	±1 dB
Harmonic Distortion (25 kHz Deviation)	< 1% 50 Hz to 15 kHz
Amplitude Modulation Noise	> 50 dB
Frequency Modulation Noise	> 60 dB
Intercarrier Stability	±250 Hz

Physical Characteristics

Power Requirements	
Power Supply	230 V _{AC} , 10 A _{AC}
Operating Temperature	0 - 50°C
Dimensions	
TAU-500 Power Amplifier	W-19" flange (17" encl.), D-25- ¹ / ₄ ", H-8- ³ / ₄ " (5U)
Power Supply	W-19" flange (17" encl.), D-2- ¹ / ₄ ", H-7" (4U)

Section IV – RF Components

Amplifier Pallets

The TECH-30U driver pallet consists of (2) separate printed circuit board stages – The first stage is an ultra-linear class-A stage with (3) gain sections providing a typical adjustable power gain of 26dB to 37dB at 10-watts peak. This stage typically draws 2.5 Adc quiescent and a maximum drain current of 5 Adc. The second stage is a linear class AB stage with a typical gain of 13 dB. This stage typically draws 1.0 Adc quiescent and a maximum drain current of 10 Adc. The currents on both stages can be found by measuring the voltage drop across the +30 Vdc input and the I sense connector. The resistance separating these connections is 0.01 ohms, providing a 10 mV per ampere ratio.

The P300-UHF pallets used in the final amplification stage use LDMOS (Laterally Diffused Metal Oxide Semiconductor) technology. LDMOS technology offers higher gain, efficiency and linearity over standard MOSFET and Bipolar devices and enhances ruggedness and reliability. LDMOS transistors have the added advantage of not having BEO (Beryllium Oxide) in their construction. The P300-UHF amplifier pallets have a typical gain of 15dB (14dB minimum) and draw no more than 23Adc. Currents for these pallets must be measured with an ammeter in series with the power supply lead.

Each of the amplifier pallets is connectorized to optimize servicing and accessibility. All amplifier pallets must have the transistor drain voltages reach at least 26Vdc before the RF drive is applied.

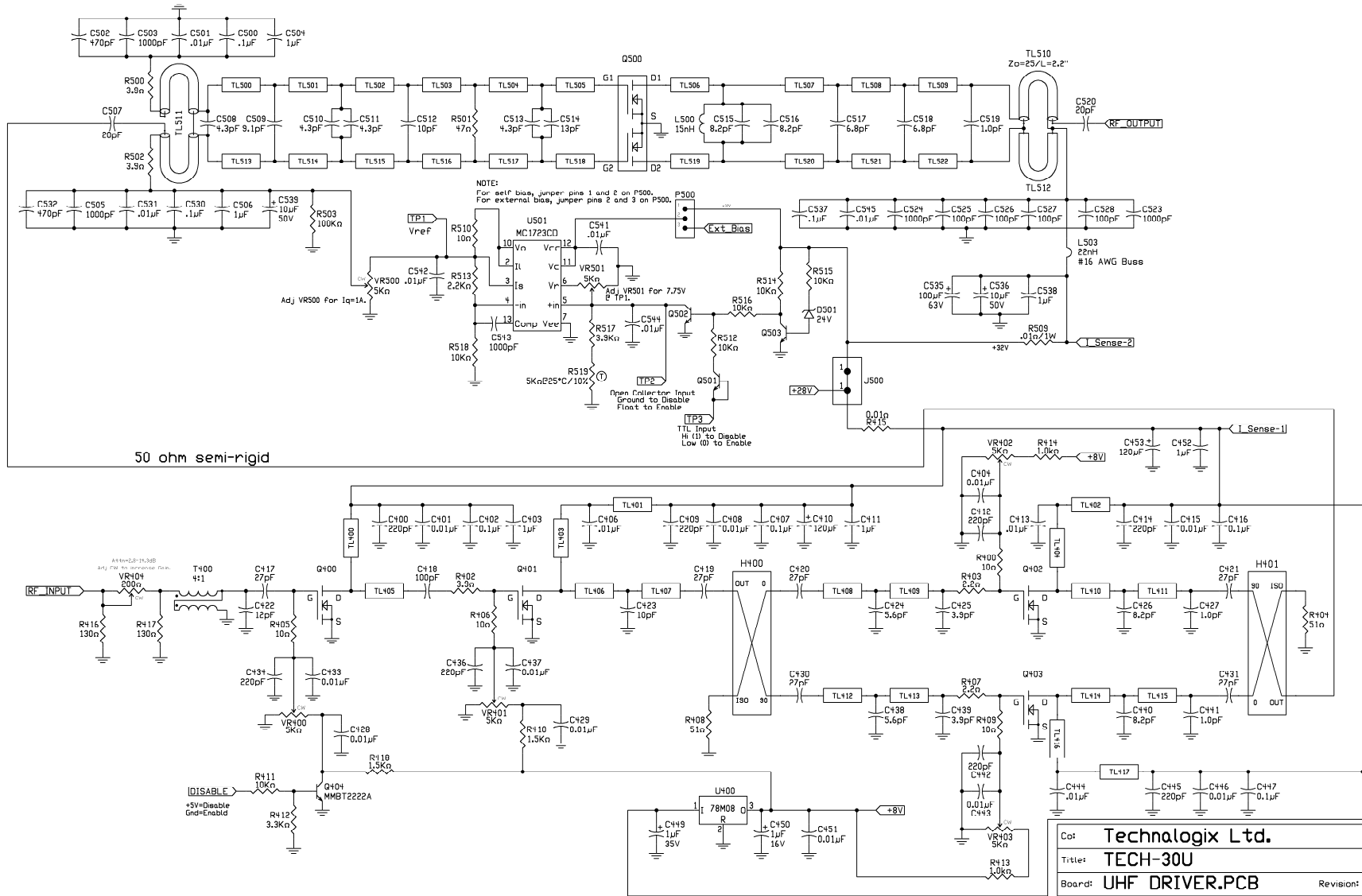

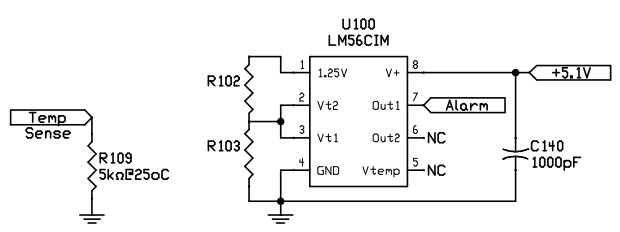
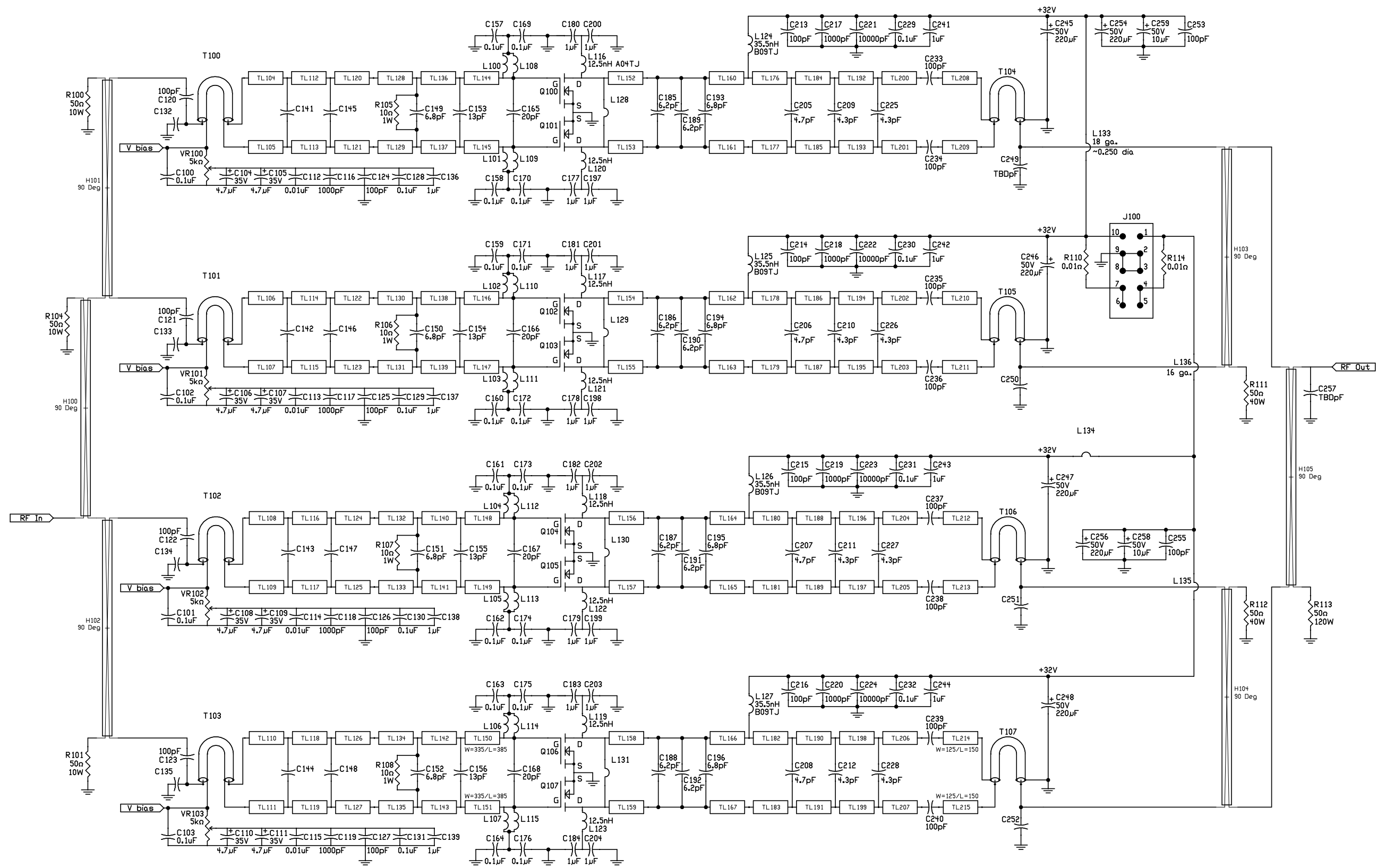

P300-UHF-16 Schematic



The company that can.

Splitter/Combiner

The splitter and combiner are used to split the RF signal into, and combine the amplified RF signal out of the (2) final amplifier pallets. The connectorized designs are based on the simple isolated Wilkinson combiner design. Due to its electrical and mechanical symmetry, the Wilkinson design's performance over moderate bandwidths is superior to other types.

Directional Coupler

The Technalogix dual directional couplers provide DC voltages proportional to forward and reflected RF power monitoring. These analog voltages are converted for processing using analog-to-digital converters and provide the control system with valuable data for monitoring purposes. The directional couplers installed in the power amplifier and filter enclosures have peak detection circuits on the forward RF power side of the coupler and average detection circuits on the reflected RF power side of the coupler. This is to allow the end user to set power in a manner that is more independent of modulation and closer to a true tip-of-sync meter. Hence the readings on the displays in the power amplifier system are peak for forward and average for reflected. Output power should be set following the operating procedure found elsewhere in this manual.

The directional coupler has a typical insertion loss of 0.5dB and its Type N connectors can handle 1,500 watts peak. The coupler requires 8 to 8.5Vdc to power the internal electronics of the coupler and is supplied from the control printed circuit board at the front of each enclosure.

Isolator

The power amplifier pallets are protected in part by the isolator located in the filter enclosure. It is actually made up of a circulator and 50-ohm dump resistor. The circulators' specifications include an insertion loss of less than 0.2dB with an isolation rating better than 20dB. Any reflected power gets dumped into the flanged power resistor. Even though the flanged power resistor is rated for only 150-watts, and there could potentially be 500-watts being reflected back into the circulator, the software will recognize quickly that reflected power is present and turn the carrier off. This way, there is instantaneous protection due to the isolator setup and long term protection due to the software.

Filter

The passive bandpass filter rejects spurious and harmonic output products and passes the UHF channel RF output. The cavity resonator uses aperture coupling and is a linear resonator design. Typical insertion loss is 0.6 dB to 1.0 dB depending on channel frequency. Average roll off is -33 dBc at a point 4.5 MHz below the peak visual carrier frequency and -30 dBc 9.0 MHz above the peak visual carrier frequency. The filter is DC grounded on both the input and output for additional lightning protection.

Section V – Power Supply

Switching AC-DC power supplies are used to power the amplifier pallets, the control circuits, and all of the fans. There are (2) power supplies paralleled in the power supply enclosure to generate the necessary current for the amplifier pallets. These (2) supplies are paralleled at 31.0 Vdc nominally and fed to the power amplifier enclosure via 4-AWG multi-stranded conductors and high current connectors. There are no power supplies internal to the power amplifier enclosure, with the exception of those found on the Series IIG control PCB. All fans run off of this same supply, though they pass through a series dropping resistor to lower the supply voltage down, as the fans are 24Vdc.

The power supplies in the power supply enclosure are (2) Mean Well PSP-1000. The switching power supplies are fully protected against short circuit and output overload. Short circuit protection is a cycling type power limit. The internal AC fuse is designed to blow only on a catastrophic failure in the unit – the fuse does not blow on overload or short circuit. The thermal shutdown automatically recovers when the power supply chassis cools down.

AC (220Vac) is fed into the power supply enclosure via a filtered AC entry and then through a resettable circuit breaker. It is then current limited with a resettable circuit breaker before passing through a rocker switch. This switch turns the AC on and off to the switching power supply.



MEAN WELL

SWITCHING POWER SUPPLY

ISO-9001 CERTIFIED MANUFACTURER

PSP-1000 SERIES

- .LOW COST, HIGH RELIABILITY
- .100% FULL LOAD BURN-IN TEST
- .BUILT IN EMI FILTER, CURRENT SHARING CIRCUIT
- .105°C OUTPUT CAPACITOR
- .BUILT IN REMOTE CONTROL, REMOTE SENSE, POWER GOOD SIGNAL
- .BUILT IN PFC CIRCUIT PFC>=0.95, COMPLIES WITH EN61000-3-2
- .SHORT CIRCUIT, OVERLOAD, OVER VOLTAGE, OVER TEMP. PROTECTED



MODEL	PSP-1000-5	PSP-1000-12	PSP-1000-13.5	PSP-1000-15	PSP-1000-24	PSP-1000-27	PSP-1000-48
DC OUTPUT VOLTAGE	5V	12V	13.5V	15V	24V	27V	48V
OUTPUT V. TOLERANCE	±2%	±1%	±1%	±1%	±1%	±1%	±1%
OUTPUT RATED CURRENT	145A	75A	67A	60A	37.6A	33.6A	19A
OUTPUT CURRENT RANGE	0-145A	0-75A	0-67A	0-60A	0-37.6A	0-33.6A	0-19A
RIPPLE & NOISE	200mVp-p	200mVp-p	200mVp-p	200mVp-p	200mVp-p	200mVp-p	200mVp-p
LINE REGULATION	±1%	±0.5%	±0.5%	±0.5%	±0.5%	±0.5%	±0.5%
LOAD REGULATION	±2%	±1%	±1%	±1%	±1%	±1%	±1%
DC OUTPUT POWER	725W	900W	904.5W	900W	902.4W	907.2W	912W
PEAK OUTPUT POWER	800W	1000W	1000W	1000W	1000W	1000W	1000W
EFFICIENCY	76%	82%	82%	82%	84%	84%	86%
DC VOLTAGE ADJ.	4.75-5.5V	10-13.2V	12-15V	13.5-18V	20-26.4V	24-30V	41-56V
INPUT VOLTAGE RANGE	90-264VAC 47-63Hz; 127-370VDC						
AC CURRENT	14A/115V 7A/230V						
POWER FACTOR	0.95/230VAC						
INRUSH CURRENT	35A/115V 70A/230V						
LEAKAGE CURRENT	<2mA/240VAC						
OVERLOAD PROTECTION	115%-140% TYPE:CONSTANT CURRENT LIMITING RESET:AUTO RECOVERY						
OVER VOLTAGE PROTECTION	5.75-6.75	13.8-16.2V	15.5-18.2V	18-21V	27.6-32.4V	31-36.5V	57.6-67.2V
OVER TEMP.PROTECTION	RTH2>=95°C OUTPUT SHUTDOWN						
REMOTE CONTROL	RC+/RC-: 0-0.8V=POWER ON; 4-10V=POWER OFF SINK CURRENT 4-10mA						
TEMP. COEFFICIENT	±0.03% / °C (0-50°C)						
SETUP, RISE, HOLD UP TIME	1.5s, 50ms, 15ms						
VIBRATION	10-500Hz, 2G 10min./1cycle, PERIOD FOR 60min. EACH AXES						
WITHSTAND VOLTAGE	I/P-O/P:3KVAC I/P-FG:1.5KVAC O/P-FG:0.5KVAC						
ISOLATION RESISTANCE	I/P-O/P, I/P-FG, O/P-FG:500VDC / 100M Ohms						
WORKING TEMP., HUMIDITY	-10°C~+60°C(REFER TO OUTPUT DERATING CURVE), 20%-90% RH						
STORAGE TEMP., HUMIDITY	-20°C~+85°C, 10%-95% RH						
DIMENSION	278*129*127mm						
WEIGHT	4.7 Kgs						
SAFETY STANDARDS	MEET UL1950						
EMC STANDARDS	MEET CISPR22, EN61000-3-2, EN61000-4-2,3,4,5,6,8,11						

NOTE :

- 1.ALL PARAMETERS ARE SPECIFIED AT 230VAC INPUT, RATED LOAD, 25°C 70% RH. AMBIENT.
- 2.TOLERANCE INCLUDE SET UP TOLERANCE, LINE REGULATION, LOAD REGULATION.
- 3.RIPPLE & NOISE ARE MEASURED AT 20MHz BY USING A 12" TWISTED PAIR TERMINATED WITH A 0.1uF & 47uF CAPACITOR.
- 4.LINE REGULATION IS MEASURED FROM LOW LINE TO HIGH LINE AT RATED LOAD.
- 5.LOAD REGULATION IS MEASURED FROM 0% TO 100% RATED LOAD.
- 6.REFER TO OUTPUT DERATING CURVE VS INPUT VOLTAGE.
- 7.PEAK OUTPUT POWER LASTING <30 SECONDS WITH A MAX. 10% DUTY CYCLE.

BLOCK DIAGRAM

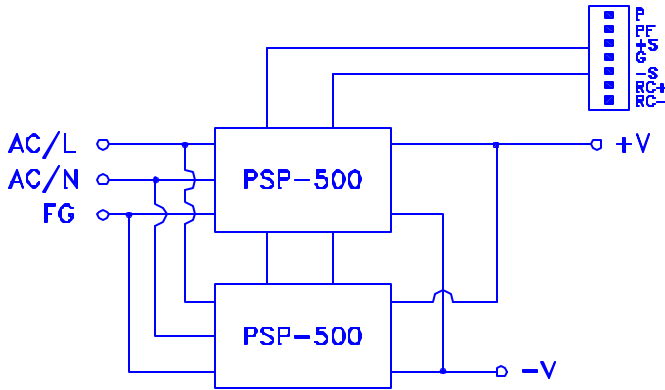

OUTPUT DERATING VS T_a

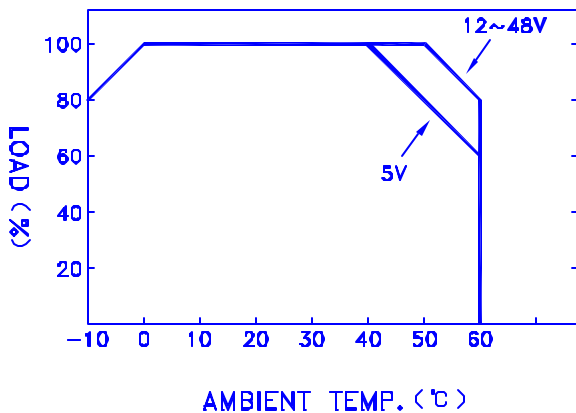

OUTPUT DERATING VS INPUT VOLTAGE

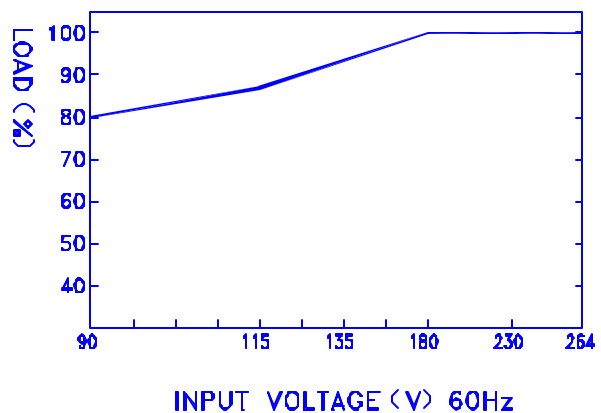

DIMENSION (mm)

- ☒ CASE : 924
- ☒ I/P TERMINAL PIN NO. ASSIGNMENT
- ☒ PIN 1,2 : AC INPUT
- ☒ PIN 3 : FG \perp
- ☒ O/P TERMINAL PIN NO. ASSIGNMENT
- ☒ PIN 1,3: DC OUTPUT +V
- ☒ PIN 2,4: DC OUTPUT -V

- ☒ CONTROL PIN NO. ASSIGNMENT
- ☒ Molex 5559-NP Uses 5558 Male Crimp Terminal
- ☒ PIN 1 : P(CURRENT SHARE)
- ☒ PIN 2 : -S
- ☒ PIN 3 : G
- ☒ PIN 4 : RC-
- ☒ PIN 5 : NC
- ☒ PIN 6 : PF(POWER FAIL SIGNAL)
- ☒ PIN 7 : +S
- ☒ PIN 8 : RC+
- ☒ MATING CONNECTOR
- ☒ Molex 5557-NR Uses 5556 Female Crimp Terminal Receptacle

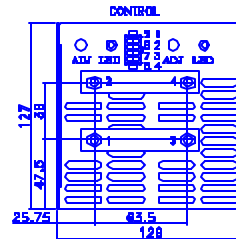
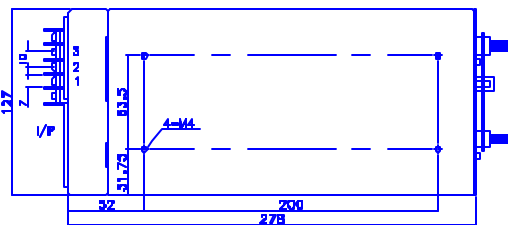
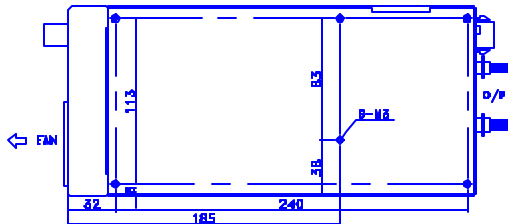
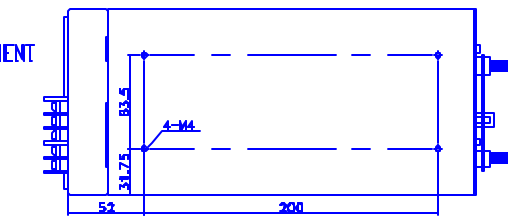
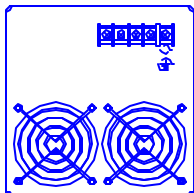

Section VI – Monitor and Control System

Control Board Overview (Series II-rev I)

The control printed circuit boards (PCB) are located at the front of each enclosure connected directly to the back of the liquid crystal displays (LCD) and are identified as Series II – rev I PCBs. The main purpose of the Series II - rev I PCB is to monitor the RF power and the DC supply voltages in the power amplifier and filter enclosures and to monitor just the DC supply voltages in the power supply enclosure. In all cases, a DC voltage proportional to the parameter being sampled is conditioned, protected, buffered, and then run into an analog-to-digital converter (ADC) where software processes the signal. The software processing determines if the parameters are within the predetermined safe operating levels and displays the parameters on the LCD for monitoring purposes. The Series II - rev I PCB can be broken apart into (5) main component areas: the power supply, interface, signal processing, display, and microcontroller. Schematics are found later in this section.

Power Supply Components

There are (4) power supply voltages generated on the Series II – rev I PCB:

1. +5Vdc for all logic and general purpose PCB supply voltage
2. +4Vdc for the LED backlighting on the LCD
3. -4Vdc for the contrast voltage required by the LCD
4. +5Vdc for the directional coupler supply

The +5Vdc is generated from a small switching power supply comprised of C101, C102, D102, L101, and U101. This power supply accepts DC input voltages up to 40Vdc (unless U101 is an HV option, then the maximum input voltage is +60Vdc) and outputs +5Vdc at up to 1Adc. This voltage is always on, as the ON/OFF pin on U101 is hard-wired to the 'on' configuration. C103, L102, and C104 form a noise choke to help filter out switching noise or RF noise that may radiate onto the control circuit board.

The +4Vdc is generated from a small switching power supply comprised of components C105, C106, D103, L103, and U102. This power supply accepts DC input voltages up to +40Vdc (unless U102 is an HV option, then the maximum input voltage is 60Vdc) and outputs +5Vdc at up to 1Adc. The voltage then gets dropped down to +4Vdc through R101. This backlight voltage can be turned on and off via the ON/OFF pin on U102. The PCB is designed in a manner that allows this voltage to be hard-wired on all the time or controlled from the microcontroller through latch U111. This selection is made with jumper J102.

The -4Vdc is generated using a switched capacitor voltage converter design, using components C109, C110, R102, R103, U104, and VR101. U4 accepts +5Vdc from the general purpose +5Vdc supply and generates -5Vdc. This voltage then gets dropped across the voltage divider (R102, R103) to generate the contrast voltage specific to the LCD that is installed in the system.

The voltage required by the directional coupler is generated with a standard linear voltage regulator, U103 if it is a voltage other than +5Vdc. C107 and C108 helps clean up any ripple or noise that might be on the output voltage. In the standard configuration, where the directional coupler requires +5Vdc, the +5Vdc is simply taken from the U101 filtered power supply output.

Interface Components

The interface section of the Series II – rev I PCB includes the front panel switch interfacing in addition to the buzzer and carrier disable output circuits.

The (4) membrane switches found on the front panels of each enclosure are tied to the microcontroller through an isolation stage to avoid any static discharge or noise on the switch wiring from reaching the microcontroller. Optoisolators U105 and U106, in addition to components R104...R115 create the necessary isolation to the sensitive microcontroller. By depressing any membrane switch, a ground (0V) is applied to the input of the optoisolators. The optoisolators will, in turn, output a ground (0V) to the microcontroller when any switch is depressed.

The membrane switches found on the front panels of the enclosures operate in the following manner with a depress:

POWER – When unit is plugged in, AC is supplied to the switching power supply input, but the amplifiers are still turned off. In order to turn the amplifiers on, assuming the rocker switch is turned on, wait ten seconds after plugging the PA in and push in the “POWER” tactile button. The LCD will read “Soft Start Warm Up, Please Wait”. After ten seconds the bias voltages will be turned on and you may then plug in the RF drive. Depress for (1) second to turn on and (3) seconds to turn system off. In the case of multiple enclosures, all POWER switches are tied together in each enclosure, so only one switch needs to be depressed.

NAVIGATE – Turns on backlight to LCD and displays forward and reflected RF power and DC supply voltage parameters. When power amplifier is first turned on, the LCD comes on automatically and this information is displayed. Information is displayed for several minutes before the backlight turns off and the display is cleared. This is set up so as not to burn any pixels into the LCD from extended on time. In the case of multiple enclosures, the NAVIGATE switches are individual to each enclosure.

SELECT – Turns on backlight to LCD and displays forward and reflected RF power and DC supply voltage parameters. When power amplifier is first turned on, the LCD comes on automatically and this information is displayed. Information is displayed for several minutes before the backlight turns off and the display is cleared. This is set up so as not to burn any pixels into the LCD from extended on time. In the case of multiple enclosures, the SELECT switches are individual to each enclosure.

RESET – Tactile switch resets the monitor and control system. The amplifier gets shut down for under 0.5 seconds and comes back on with each depress of the reset button. At the same time, all fault counters in the microcontroller software are reset and the LCD is reset in the same manner as it is with a depress of the NAVIGATE button. Reset switches are individual to each enclosure but may be tied together externally through the remote port, as explained later in this section.

The buzzer control comes from pin 7 on microcontroller U114. The control signal passes through R116 and turns on the base of transistor Q101, which allows current to flow through the single tone magnetic buzzer. Jumper J105 simply turns off the buzzer when removed.

The carrier disable circuit applies a shutdown voltage to the driver pallet in the system. The U114 generates the signal out of pin 21 and controls transistor Q102 through R117. When Q102 is turned off, the shutdown voltage to the driver is floating and the carrier is on. During a fault condition, when Q102 is turned on, the shutdown voltage is applied to the carrier disable on the driver. Relay K101, which outputs the carrier disable, is protected from transient spikes by D104.

Signal Conditioning Components

The signal processing section of the Series II – rev I PCBs is used to buffer potentially noisy or damaging signals from the ADC. Power supply samples and forward and reflected power from a directional coupler are then digitized.

Firstly, all analog signals are protected with a resettable fuse and transient voltage suppressor (TVS) combination. These components ensure that voltages above the V_{br} breakdown voltage of the TVS get clamped and do not pass farther down the circuit. After this protection stage, the analog voltages get dropped with voltage dividers to safe levels for the buffers and ADC. For example, a +30Vdc power supply sample gets dropped to a level below the +2.5Vdc voltage reference U109 of the ADC. After the voltage dividers, the analog signals get buffered with U107 and U108, configured as unity gain voltage followers. Finally, after some further decoupling capacitors and filters, the analog signals get digitized by the 8-channel, 10-bit ADC (U10) and sent to the microcontroller through a serial interface.

There are (3) analog voltages that get conditioned and processed: DC power supply sample, forward RF power, and reflected RF power. Specifically, the components are as follows:

- DC power supply – J108 (pin 1 floating and direct connection), F107, C120, L108, C121, R129, R130, VR105, U108, C122, C123, L109, C124 and U110.
- Forward RF power – J108 (pin 2), F106, D109, C117, C118, L107, C119, R127, R128, VR104, U108, C125, L110, C126, C127, and U110.
- Reflected RF power – J108 (pin 3), F105, D108, C114, C115, L106, C116, R125, R126, VR103, U108, C130, L112, C131, C132, and U110.

Display Components

The display section of the Series II – rev I PCB is comprised of the LCD and the components that make up the data bus to send the data from the microcontroller to the LCD.

Specifically, the LCD is an alphanumeric 20X4 display that uses the industry standard 44780 controller and a parallel interface for data communications. Firstly, the microcontroller sends out the data to be displayed via a serial bus where the signals are latched with U111 and U112 and converted to a parallel data stream. The parallel data then transfers directly to the LCD through connector J109. J109 also carries the power supply for the LCD.

Microcontroller Components

The heart of the monitor and control system found in Series II - rev I PCBs is microcontroller U114. This microcontroller analyzes all RF power levels and voltages to ensure that all operating parameters are within their predetermined safe operating levels. If a fault is found, appropriate action is taken to help protect the system from damage, which may include turning the RF carriers off. A full description of all faults and their respective actions is found later in this section.

The power supply for the microcontroller is monitored closely via supervisor U113. Should the +5Vdc supply drop below +4.5Vdc, a microcontroller reset is generated to ensure there are no brown out conditions that may latch the microcontroller up to an unknown state. The front panel Reset momentary switch is also tied to this line after optoisolation. The microcontroller is run off of a 4.000MHz clock source, generated by ceramic resonator CR101. If the software is running, LED D110 will be lit. Finally, U115 stores all characters for the LCD to minimize the overhead required for the microcontroller, and also stores the current state of the power ON/OFF of the system. This is to ensure that, in the event of a power outage, the system returns to the exact state it was before power was interrupted.

Fault Shutdowns

On the LCD (Liquid Crystal Display) the following messages may appear:



If you see this message, the system will:

- shut amp down for 1 minute
- automatically turn amp on after 1 minute and check again for overdriven amplifier
- come back to the same power level that it was set



If you see this message, the system will:

- shut amp down for 5 minutes
- automatically turn amp on after 5 minutes and check again for high VSWR
- come back to the same power level that it was set

Remote Port

The remote port allows external control of the transmission system via the DB25 connector on each enclosure. All functions on the remote port are simply hard-wired or paralleled to existing wiring to provide a secondary method of control to the user, and are activated as follows:

- pin 1: ground to reset microcontroller, float otherwise
- pin 2: ground for 2 seconds to toggle carrier on/off, float otherwise
- pin 3: common ground
- pin 4: DC power supply sample

Series II - Bill of Materials

revision: I
date: 21-Jun-05

Optional part depending on power level of TV or FM

Item	Qty	Components	Description	Tolerance	Package	Equivalency
1	1	BZ101	BUZZER, magnetic, 5V, single tone		SMD CT-1205C	CUI CT-1205C
2	2	C101, C105	CAPACITOR, electrolytic, 100uF, 63V	<=20%	SMT (Panasonic VS "G" size)	Panasonic ECE-V1JA101P, NIC NACEW101M63V10x10.5
3	2	C102, C106	CAPACITOR, electrolytic, 330uF, 35V	<=20%	SMT (Panasonic VS "G" size)	Panasonic ECE-V1VA331P, NIC NACEW331M35V10x10.5
4	21	C103, C104, C107, C112, C113, C115, C116, C118, C119, C120, C121, C123, C124, C125, C126, C128, C129, C130, C131, C133, C134	CAPACITOR, ceramic, 0.01uF, 63V	<=20%	SMT 0805	Digikey C0805C103K5RACTU
5	7	C108, C111, C140, C143, C144, C145, C146	CAPACITOR, ceramic, 0.1uF, 25V	<=20%	SMT 1206	Utech GMC31X7R104K50NT
6	2	C109, C110	CAPACITOR, electrolytic, 100uF, 25V	<=20%	SMT (Panasonic VS "E" size)	Panasonic ECE-V1EA101UP
7	7	C114, C117, C122, C127, C132, C135, C147	CAPACITOR, tantalum, 1uF, 16V	<=20%	SMT 3216	Sprague 293D105X9035B2T
8	1	CR101	CLOCK, ceramic resonator, 4.000 MHz, w/caps	f <= 0.5% C <= 20%	Through hole, 3-position, 0.1" spacing	ECS Inc. ZTT-4.00MG
9	1	D101	TV Power Amplifier: DIODE, TVS, 600 watts, Vwm=30V, Vbr min=33.3		SMB	Crydom SMBJ30A; GI SMBJ30A
10	1	D101	FM Power Amplifier: DIODE, TVS, 600 watts, Vwm=48V, Vbr min=53.3		SMB	Crydom SMBJ48A; GI SMBJ48A
11	2	D102, D103	DIODE, schottky, If=3A, Vr=60V		SMC	International Rectifier 30BQ060
12	1	D104	DIODE, rectifier, If=1A, Vr=200V		SMA	Diodes Inc S1D-13
13	2	D108, D109	DIODE, TVS, 600 watts, Vwm=5.0V, Vbr min=6.4		SMB	Crydom SMBJ5.0A; GI SMBJ5.0A
14	1	D110	DIODE, LED, RED, clear or diffused		SMT 1206	Lumex SML-LX1206IW
15	1	F101	FUSE, resettable, Ihold=0.75A, Itrip=1.5A, Vmax=72V		0.23" lead spacing, 20AWG leads	Raychem RXE075; Bourns MF-R075
16	3	F105, F106, F107	FUSE, resettable, Ihold=0.14A, Itrip=0.34A, Vmax=60V		miniSMD	Raychem miniSMDC014-2
17	1	J101	CONNECTOR, 4-position plug, 180 degree wire entry, 90 degree screw access, 5.08mm		0.2" spacing	Wieland 25.340.3453, Weco 10.808.104
18	1	J101	CONNECTOR, 4-position header, pluggable, vertical, closed, 5.08mm		Through hole, 0.2" spacing	Wieland 25.350.3453, Weco 20.806.128
19	2	J102, J106	CONNECTOR, breakout header strip, 3-position, 0.1", square post		Through hole, 0.1" spacing	Molex 22-28-4300; Samtec TSW-130-05-T-S
20	1	J105	CONNECTOR, breakout header strip, 2-position, 0.1", square post		Through hole, 0.1" spacing	Molex 22-28-4300; Samtec TSW-130-05-T-S
21	3	J102, J105, J106	CONNECTOR, 2-position post shunts		0.1" spacing	AMP 382811-6; Samtec SNT-100-BK-T
22	1	J103	CONNECTOR, 5-position plug, 180 degree wire entry, 90 degree screw access, 5.08mm		0.2" spacing	Wieland 25.340.3553.0
23	1	J103	CONNECTOR, 5-position header, 0.1", vertical		Through hole 0.2" spacing	Wieland 25.350.3553.0
24	2	J107, J108	CONNECTOR, 3-position plug, 180 degree wire entry, 90 degree screw access, 5.08mm		0.2" spacing	Wieland 25.340.3353, Weco 10.808.103
25	2	J107, J108	CONNECTOR, 3-position header, pluggable, vertical, closed, 5.08mm		Through hole, 0.2" spacing	Wieland 25.350.3353, Weco 20.806.127
26	1	J109	CONNECTOR, terminal strip, 16-position		Through hole, 0.1" spacing	Samtec TSW-116-18-T-S
27	1	J109	CONNECTOR, socket strip, 16-position		Through hole, 0.1" spacing	Samtec SSW-116-03-T-S
28	1	K101	RELAY, DPDT, 5V, 2A contact, SMD		Relay - Aromat - TX SA	Aromat TX2SA-5V
29	1	L101	INDUCTOR, 680uH, Irms=0.4A, DCR=2.02 ohms		SMT	JW Miller 3316-681M
30	10	L102, L105, L106, L107, L108, L109, L110, L111, L112, L113	INDUCTOR, 0.01uH, Imax=0.45A, DCR=0.13 ohms	+/- 10%	SMT 1210	KOA KL32TE010K
31	1	L103	INDUCTOR, 680uH, Irms=1.3A, DCR=0.2 ohms		SMT (Talema S5)	Talema SWS-0.85-680
32	1	LCD101	20 X 4 character liquid crystal display, LED backlit		4-40 pem mount (4)	Varitronix 20464K
33	1	PCB101	Series II, revision H printed circuit board, soldermask, silkscreen, FR4			Alberta Printed Circuits, MPC, GRM, Enigma, ...
34	2	Q101, Q102	TRANSISTOR, NPN, Ic=1A, Vce=40V		SMT SOT-23	Fairchild MMBT2222A; Zetex FMMT2222A; Diodes Inc MMBT2222A-7
35	1	R101	RESISTOR, 4.7 ohm, 1/2 watt, carbon film	5%	SMT 2010	Panasonic ERJ-12ZYJ4R7U
36	1	R102	RESISTOR, 15.0 ohm, 1/10 watt, thick film	1%	SMD 0805	Panasonic ERJ-6ENF15R0V
37	1	R103	RESISTOR, 75.0 ohm, 1/10 watt, thick film	1%	SMD 0805	Digikey MCR10EZHF1001, Panasonic ERJ-6ENF75R0V
38	11	R104, R105, R106, R109, R110, R111, R112, R115, R116, R132, R134	RESISTOR, 1.00 kohm, 1/10 watt, thick film	1%	SMD 0805	Panasonic ERJ-6ENF1001V
39	4	R107, R108, R113, R114	RESISTOR, 10.0 kohm, 1/10 watt, thick film	1%	SMD 0805	Panasonic ERJ-6ENF1002V

Series II - Bill of Materials

revision: I

date: 21-Jun-05

Optional part depending on power level of TV or FM
--

40	1	R117	RESISTOR, 4.99 kohm, 1/10 watt, thick film	1%	SMD 0805	Panasonic ERJ-6ENF4991V
41	1	R124	RESISTOR, 13 kohm, 1/8 watt	1%	SMD 0805	Rohm MCR10EZHF1302
42	4	R125, R127, R126, R128	RESISTOR, 1 kohm, 1/8 watt	1%	SMD 0805	Rohm MCR10EZHF1001
43	1	R129	RESISTOR, 121 kohm, 1/8 watt	1%	SMD 0805	Rohm MCR10EZHF1213
44	1	R130	RES, 2.15 kohm, 1/10 watt, thick film	1%	SMD 0805	Rohm MCR10EZHF2151
45	1	R131	RES, 120 ohm, 1/10 watt, thick film	1%	SMD 0805	Panasonic ERJ-6ENF1200V
46	2	U101, U102	TV Power Amplifier: REGULATOR, switching, 5Vdc, 3A, fosc=52kHz		SMD TO-263-5	National LM2576S-5.0
47	2	U101, U102	FM Power Amplifier: REGULATOR, switching, 5Vdc, 3A, fosc=52kHz		SMD TO-263-5	National LM2576HVS-5.0
48	1	U104	REGULATOR, inverter, 100mA		SMD SOIC-8	National LM2660M; Analog Devices ADM8660, Maxxim MAX660
49	2	U105, U106	OPTOISOLATOR, dual, Viso=5300Vac		SMD DIP8	Fairchild MCT6S
50	1	U108	OP AMP, quad, low voltage		SMD SOIC-14	National LMV324M
51	1	U109	REFERENCE, 2.50V (for TV PA >= 250Wpk)	+/-0.2%	SMD SOT-23	National LM4040BIM3-2.5
52	1	U110	ADC, 10-bit, 10-channel		SMD SOIC-20	Analog Devices AD7812YR
53	2	U111, U112	LOGIC, 8-bit shift register with latches		SMD SOIC-16	Fairchild MM74HC595M; On Semi MC74HC595AD; Phillips 74HC595D
54	1	U113	SUPERVISOR, n-channel, open drain, internal pullup resistor		SMD SOT-23	MCP130T-450I
55	1	U114	MICROCONTROLLER, OTP, 4k, 22 I/O lines		Through hole DIP-28	Microchip PIC16C63A-04/SP
56	1	J111	Connector, socket, 28-position, DIP, 0.3" spacing		Through hole DIP-28	Jameco 112299CL or equivalent
57	1	U115	MEMORY, 8k X 8, EEPROM, SPI		SMD SOIC-8	Microchip 25LC640I/SN
58	1	VR101	do not stuff			
59	4	VR102, VR103, VR104, VR105	RES, variable, 10 kohm, 1-turn, 3mm		SMD Bourns TC33	Bourns TC33X-2-103E

SERIES II, REV. I - Control System

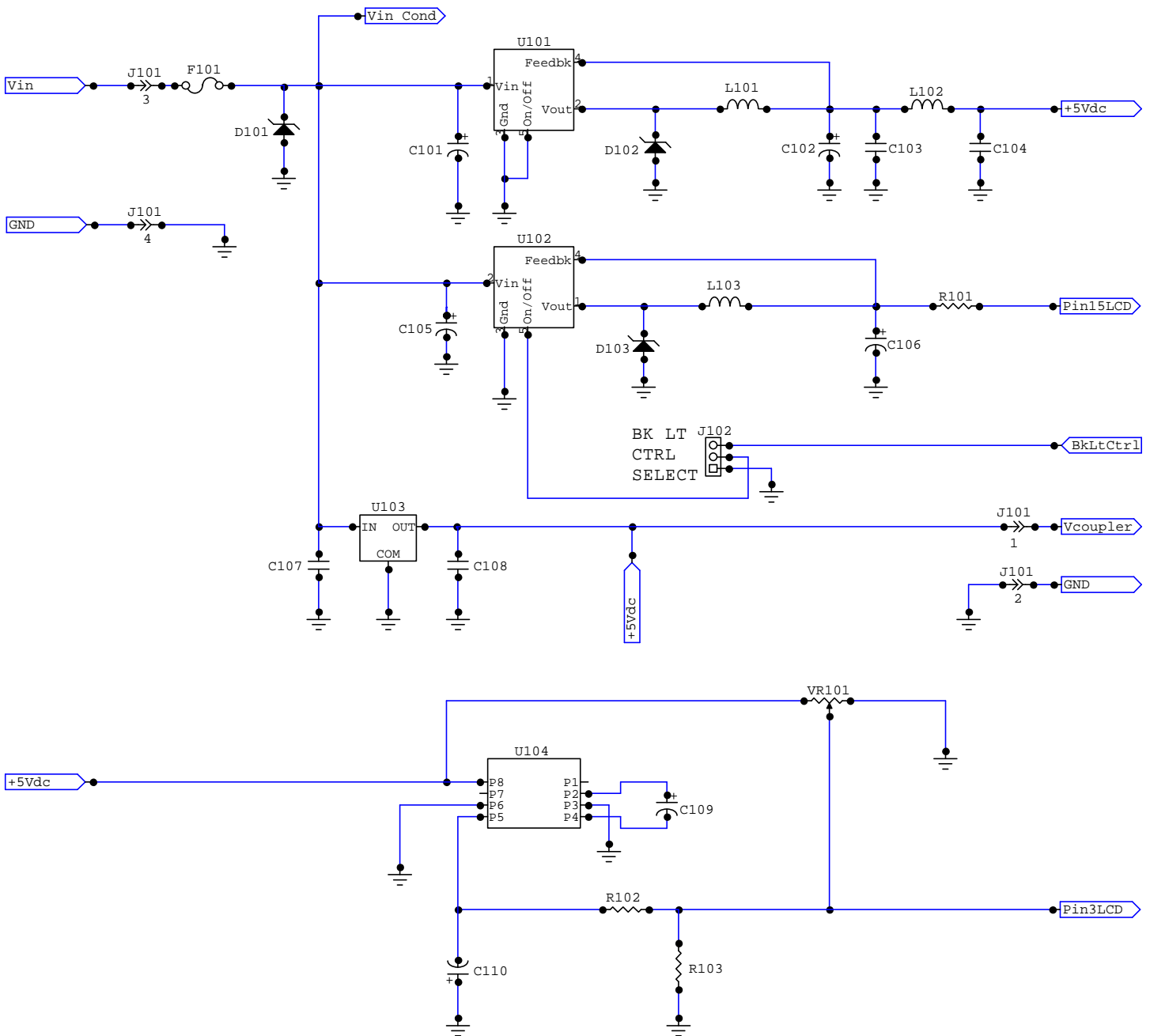

A. Sivacoe	
SERIES II: Control System	
Rev I	ID Power Supply Section
Date: March 28, 2005	Page: 1 of 1

SERIES II, REV. I - Control System

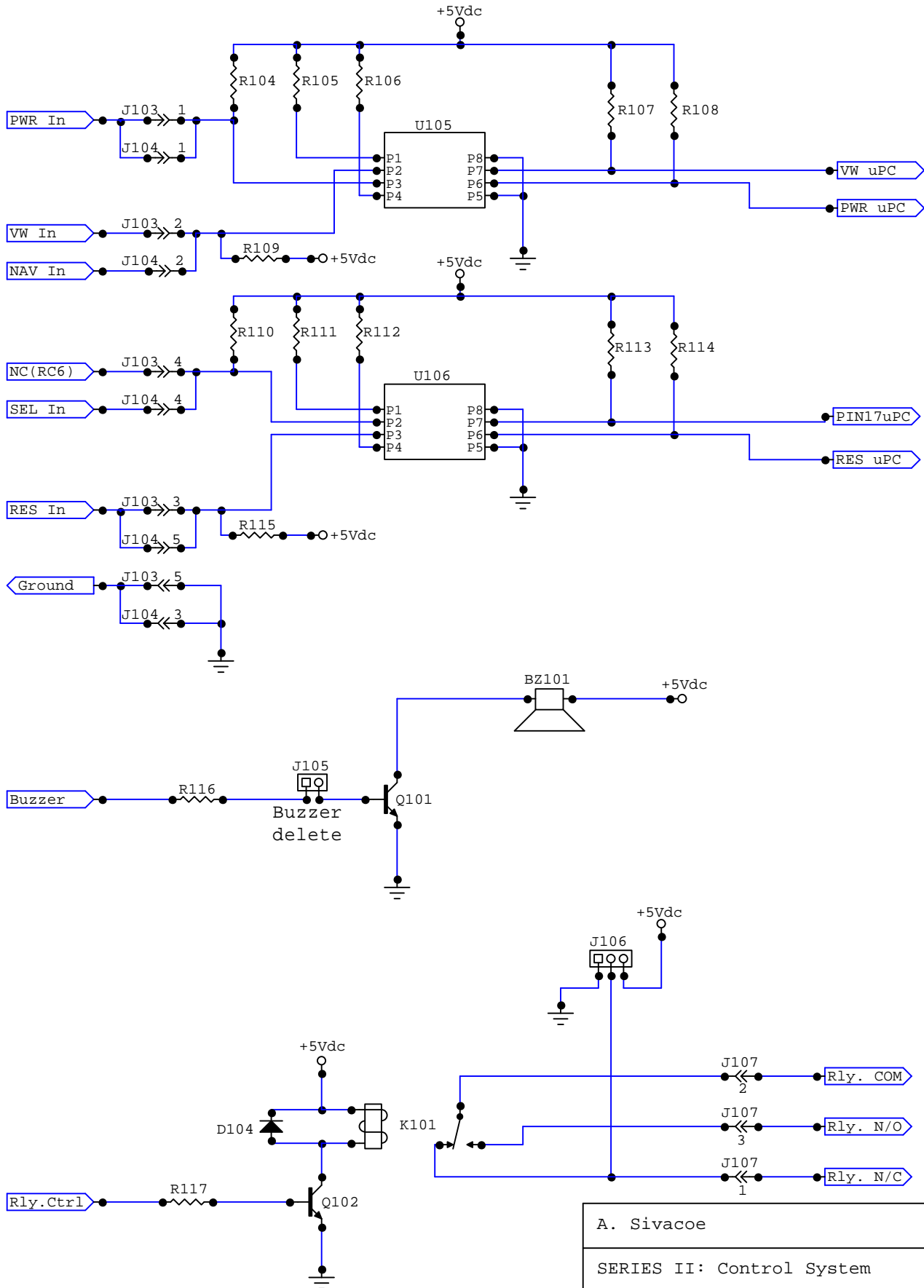

A. Sivacoe	
SERIES II: Control System	
Rev I	ID Interface Section
Date: March 21, 2005	Page: 1 of 1

SERIES II, REV. I - Control System

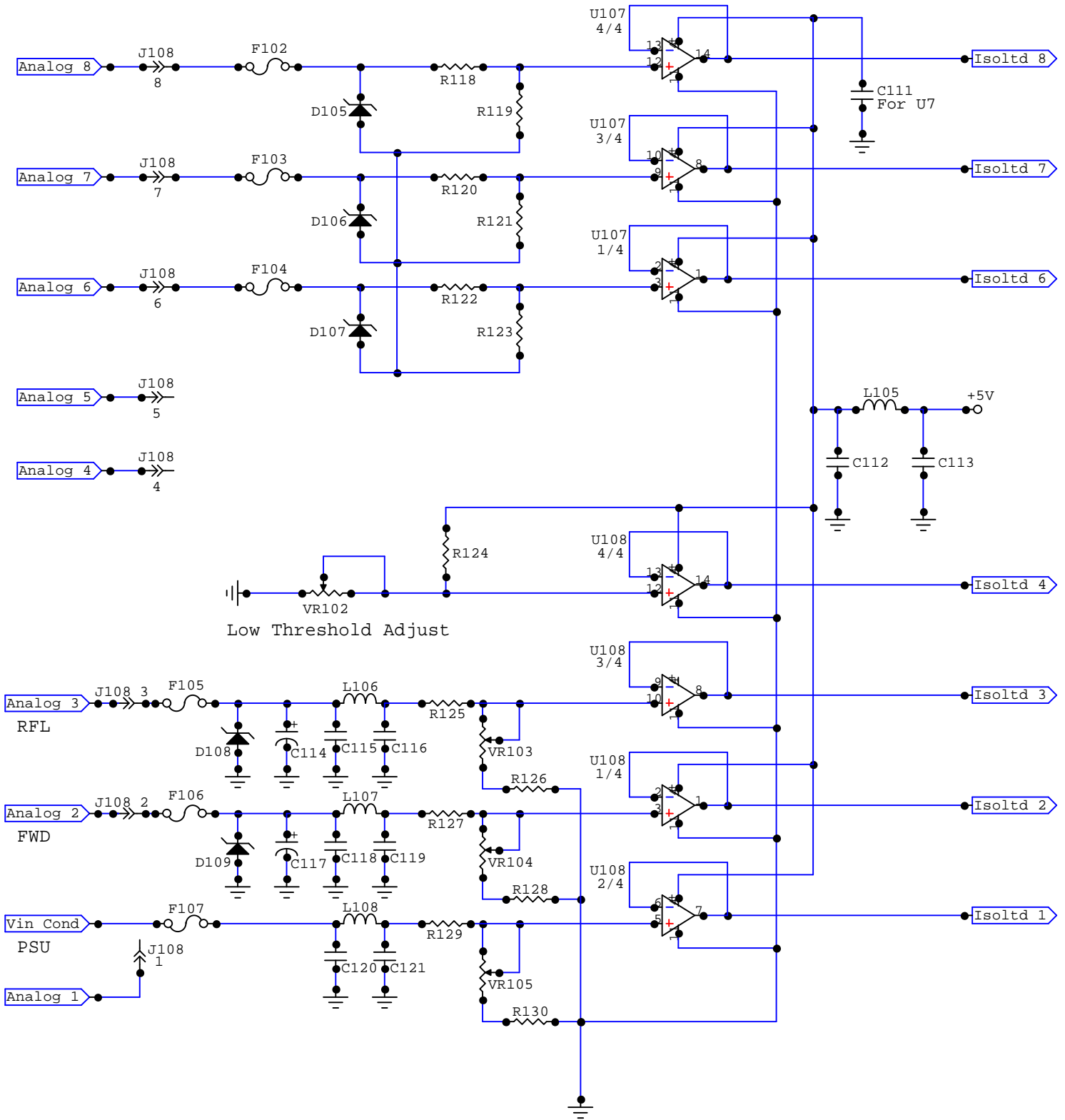

A. Sivacoe	
Series II: Control System	
Rev	ID
I	Analog Input Section
Date: March 21, 2005	Page: 1 of 1

SERIES II, REV. I - Control System

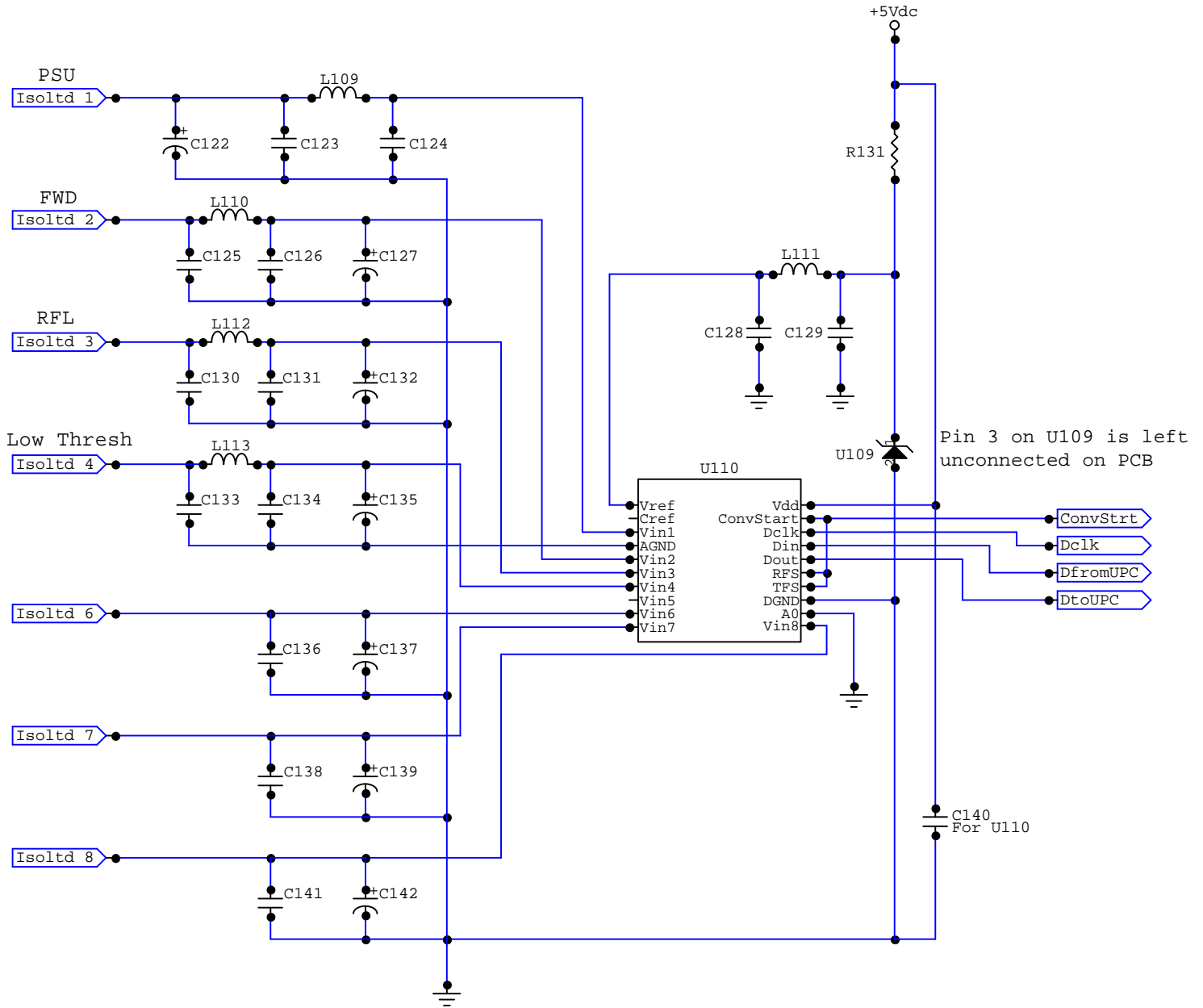

A. Sivacoe	
Series II: Control System	
Rev I	ID Analog Conversion Section
Date: March 21, 2005	Page: 1 of 1

SERIES II, REV. I - Control System

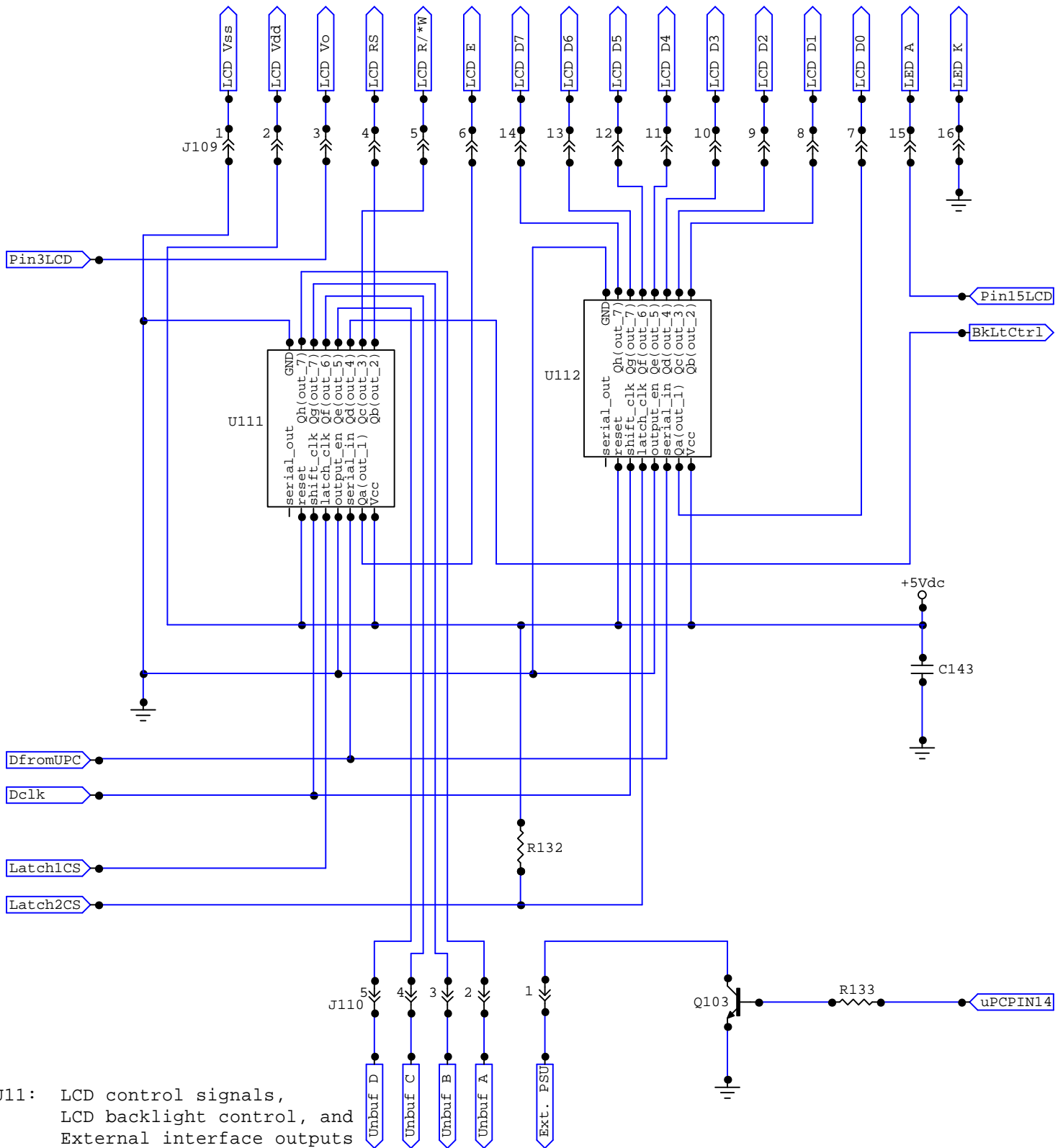

U11: LCD control signals,
LCD backlight control, and
External interface outputs

U12: LCD data bus (D0...D7)
D0...D7 is text or instruction

A. Sivacoe	
Series II: Control System	
Rev I	ID LCD Section
Date: March 2, 2005	Page: 1 of 1

SERIES II, REV. I - Control System

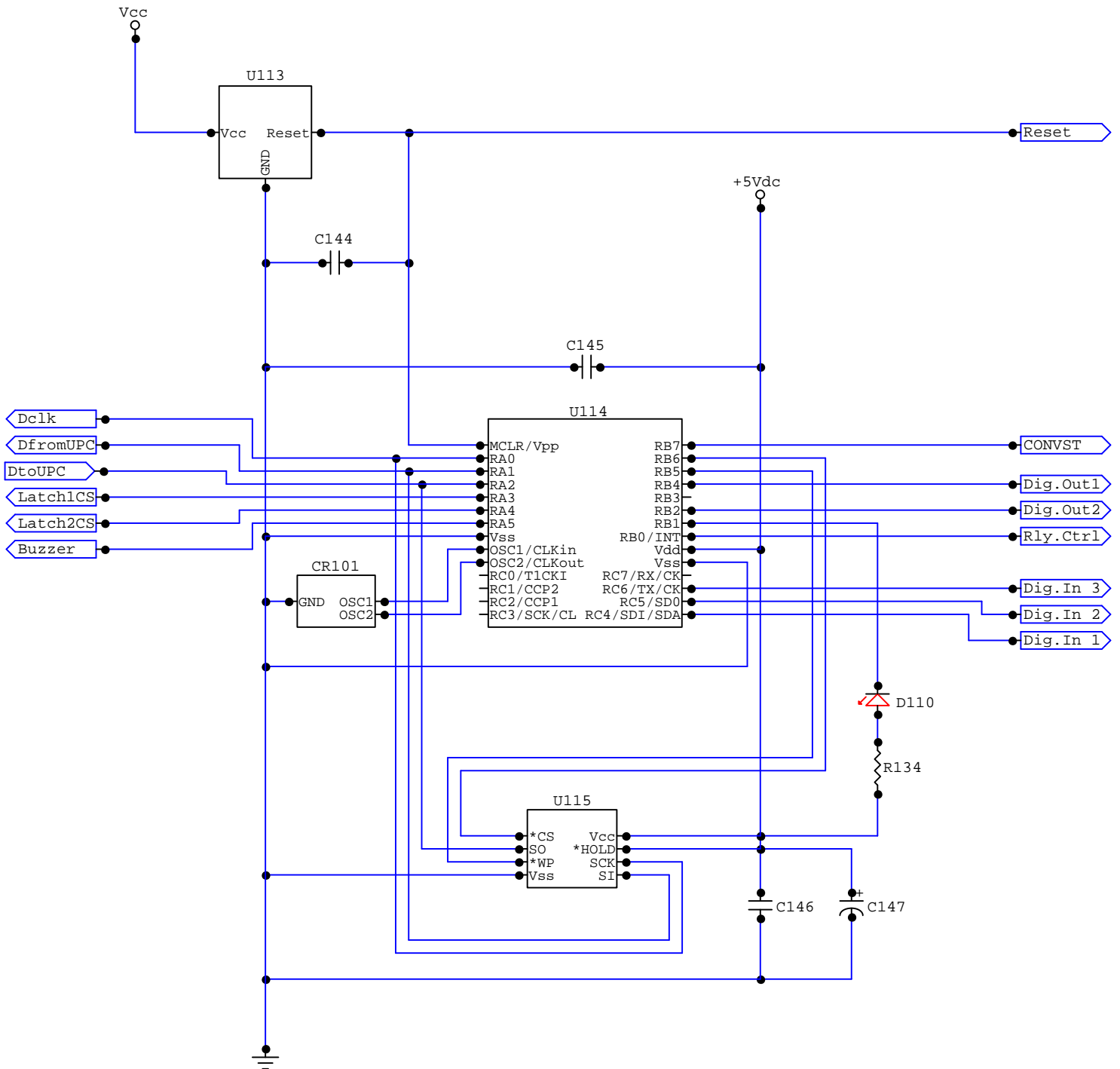

A. Sivacoe	
Series II: Control System	
Rev	ID
I	Microcontroller Section
Date: March 2, 2005	Page: 1 of 1

Remote Port
DB25

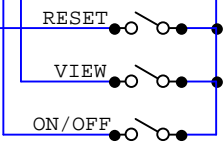
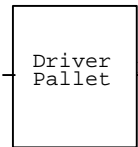
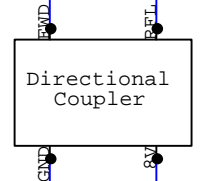
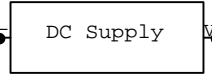
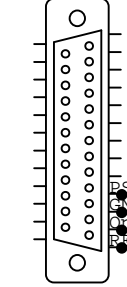

Series IIG
Control PCB

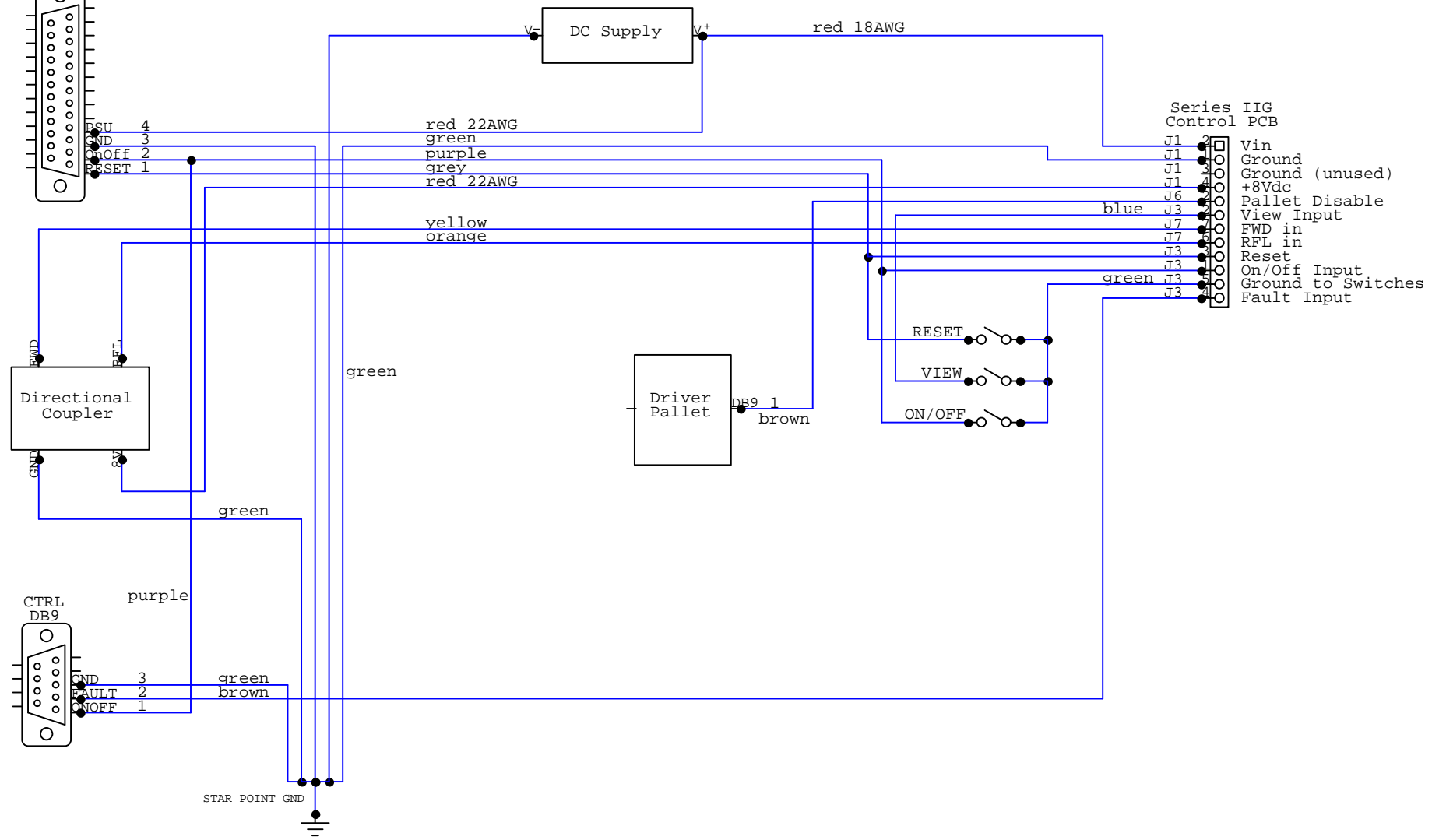
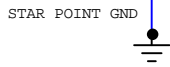
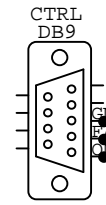
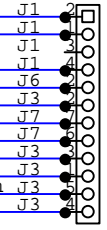

Series II Control System Wiring	
Rev I	ID
Date: June 29, 2005	Page: 1 of 1

Section VII – Mechanical Section

The heat sink allows the amplifiers to operate at a cooler temperature and prevents overheating, which helps the longevity of the entire system. The heat sink has hollow fins, which help dissipate the heat from the amplifiers faster than a conventional serrated or corrugated fin.

In addition to the cooling effects of the heat sink, within the 500-watt power amplifier enclosure, there are four fans that each provide 170 cubic feet per minute (CFM) of air flow (into zero static pressure). There are two fans mounted at the front of the heat sink and two mounted at the back end of the heat sink. The fans are mounted side-by-side to produce the best cooling for the system and are operating in a push-pull configuration to assist with heat dissipation. The fans are a 24Vdc variety, so there are series dropping resistors to drop the higher power supply voltage down to a safe level.

Section VIII - Installation

This section contains installation recommendations, unpacking, inspection, and installation instructions for the power amplifier. We are sure that you are chomping at the bit to install your new system, so we recommend that you read the following sections very carefully.

Building Recommendations

The quality of the building is of great importance if you are to expect long life and continued performance from the power amplifier. The building must be clean, dry, temperature controlled and secure. Don't forget to allow space in the building for any additional racks to house test equipment, a workbench area, line regulating transformers, ladders, equipment and parts storage, first aid kit, emergency generator if used, as well as heating and cooling devices that may be unique to your installation. A sloping roof will tend to develop leaks less rapidly. The building should be well roofed with good material. The cooling load will be lowered with reflective or light colored roofing material.

Heating and Cooling Requirements

The environment's temperature will contribute greatly to the length of the power amplifier's life. Technalogix recommends that the building's filtered air intake must have capacity for all air-flow in the building plus an additional 20%. Keep the intake below the roofline to avoid intake of solar heated air. Please ensure that the intake and exhaust areas are on the same side of the building to avoid pressure differentials during windy conditions. Also, do not position intake near exhaust's preheated air. If air conditioning is required to cool the shelter, discuss the situation with a qualified HVAC technician. Under average conditions, 12,000 BTUs will cool approximately 500 square feet to a comfortable level.

Electrical Service Recommendations

Technalogix recommends that a qualified, licensed local electrician be consulted for the required electrical service. We suggest local electricians because:

- The personnel knows the local codes
- The personnel can be on site readily
- You are apt to get better overall support if you give what business you can to local suppliers

Technalogix recommends that proper AC line conditioning and surge suppression be provided on the primary AC input to the power amplifier. All electrical service should be installed with your national electrical code in your area, any applicable provincial or state codes, and good engineering practice. Special consideration should be given to lightning protection of all systems in view of the vulnerability of most transmitter or translator sites to lightning. Lightning arrestors are recommended in the service entrance. Straight and short grounds are recommended. The electrical serviced must be well grounded. Do not connect the unit to an open delta primary power supply, as voltage fluctuations could harm the unit. Branch your circuits. Do not allow your lights, your workbench plugs, and your transmitting or translating equipment to operate on one circuit breaker. Each transmitter or translator should have its own circuit breaker, so a failure in one does not shut off the whole installation.

Antenna and Tower Recommendations

Your preliminary engineering workgroup should establish your antenna and tower requirements, both for receiving and transmitting antennas. Construction of sturdy, high quality antenna/tower systems will pay off in terms of coverage of your service area, the overall quality and saleability of your radiated signal, and reduced maintenance expenses. Technalogix provides complete turnkey antenna systems if needed. If your site is serving as a translator, your receiving antenna should be in line of sight to the originating station all year round. The foliage will change with season. Transmitting antennas can enhance or seriously impair the transmitter/translator output.

The selection, routing, and length of coaxial cable are extremely important in the installation. If there is a 3 dB line loss in the cable between your unit's output and the transmitting antenna, a 500-watt unit will only deliver 250 watts to the antenna. Buy the best cable you can obtain, route it via the shortest way to the antenna, and keep it straight. Do not form it into sharp bends on its way. Do not use any more cable fittings for the installation than absolutely necessary. All cautions here apply equally to all coaxial cables in the system - input and output.

Pay attention to radial ice accumulation when designing the transmission system. It is not uncommon for at least an inch of ice to build up on the tower and antenna. This in turn significantly increases the weight, cross section, and wind loading of the system.

Attaching the transmission line to the tower is crucial to maintain a safe and reliable operation. Nylon wire ties and electrical tape will breakdown in the sunlight and ultimately fail, creating a potentially dangerous situation. It is important to use proper clamps and hoisting grips and also ensure that the transmission line is grounded to the tower in several locations. When high currents flow through the tower in the event of lightning strikes, some of that current will through the outer conductors of the transmission lines. Due to the resistance difference between the steel tower and copper transmission line, a significant voltage can be developed, often resulting in arcing between the outer jacket and outer conductor, thus pitting the conductor.

Preventative maintenance is crucial in ensuring that safety is maintained. Specifically, check that transmission line grounds are tight and are not missing any hardware. Frequently inspect support clamps or spring hangers. Consider investing in an ice break, if you haven't already done so, as shards of falling ice can damage the transmission line – and if it is going to happen, it will happen at an important time. Check the tower light photocells and conduit.

The better-known tower manufacturers offer complete technical and safety documentation with their towers. Be sure that you have this information as it regards wind loading, guying, etc. The best-designed antenna system will function poorly if shortcuts and compromises are used during installation. Follow the manufacturer's instructions exactly, along with any engineering data prepared for the site. Be absolutely safe and certain about this aspect as human lives may be at stake.

Shelter Security

The FCC requires that the transmitter or translator be secure from entry or control by unauthorized persons, and that any hazardous voltages or other dangers (including most tower bases) be protected by locks or fences as necessary to protect personnel and prevent unauthorized tampering or operation. Security of the building further implies that it be secure from wildlife. Use sturdy construction materials, including sheet metal if necessary. Holes around conduit, cable, and other similar entry points should be stuffed with steel wool and caulked to prevent entry of wildlife. Other features of security for your shelter may include its location with respect to the prevailing wind conditions. A location leeward of some natural topographical feature will prevent wind damage and snowdrifts. Check the soil runoff conditions that may slow or hasten wind or water erosion and other concerns that may be unique to your location.

Unpacking and Inspection

Check the outside of the container. Carefully open the container and remove the power amplifier. Retain all packing material that can be reassembled in the event that the equipment must be returned to the factory.

Exercise care in handling equipment during inspection to prevent damage due to rough or careless handling.

Visually inspect the enclosure of the power amplifier for damage that may have occurred during shipment. Check for evidence of water damage, bent or warped chassis, loose screws or nuts, or extraneous packing material in connectors or fan failures. Inspect all connectors for bent connector pins. If the equipment is damaged, a claim should be filed with the carrier once the extent of the damage is assessed. Technalogix cannot stress too strongly the importance of immediate careful inspection of the equipment and subsequent immediate filing of the necessary claims against the carrier if necessary. If possible, inspect the equipment in the presence of the delivery person. If the equipment is damaged, the carrier is your first area of recourse. If the equipment is damaged and must be returned to the factory, phone for a return authorization. Claims for loss or damage may not be withheld from any payment to Technalogix, nor may any payment due be withheld pending the outcome thereof. Technalogix cannot guarantee the carrier's performance.

Location and Function of Controls and Connectors (TAU-500 Power Amplifier)

The following illustration depicts the location of the connectors when installing the 500-watt power amplifiers (TAU-500).



<i>POWER -</i>	Tactile button to turn carriers on and off. To turn off, must be depressed for at least 2 seconds. Tied internally through DB9 connectors to all other POWER buttons.
<i>NAVIGATE -</i>	Tactile button to refresh screen after two minute screen saver times out. All monitoring and protection continues during screen saver.
<i>SELECT-</i>	Tactile button to refresh screen after two minute screen saver times out. All monitoring and protection continues during screen saver.
<i>RESET -</i>	Tactile button to reset microcontroller in control board. Also clears existing faults. Individual control board with reset comes back on with soft start feature.
<i>RF IN –</i>	RF input from modulator or processor. BNC connector, 50 ohm.
<i>RF OUT –</i>	500-watt RF output. Connects to RF IN on filter enclosure. N connector, 50 ohm.
<i>DC IN –</i>	DC input from power supply enclosure. Polarized to avoid improper hook up.
<i>REMOTE PORT -</i>	pin 1: ground to reset microcontroller, float otherwise pin 2: ground for 2 seconds to toggle carrier on/off, float otherwise pin 3: common ground pin 4: DC power supply sample (28Vdc nominal)

Location and Function of Controls and Connectors (Power Supply)



<i>POWER -</i>	Tactile button to turn carriers on and off. To turn off, must be depressed for at least 2 seconds. Tied internally through DB9 connectors to all other POWER buttons.
<i>NAVIGATE -</i>	Tactile button to refresh screen after two minute screen saver times out. All monitoring and protection continues during screen saver.
<i>SELECT-</i>	Tactile button to refresh screen after two minute screen saver times out. All monitoring and protection continues during screen saver.
<i>RESET -</i>	Tactile button to reset microcontroller in control board. Also clears existing faults. Individual control board with reset comes back on with soft start feature.
<i>AC IN –</i>	AC input to switching power supply (31 V _{DC} supply for control system and power supplies). Use supplied NEMA to terminal block connector cable.
<i>DC OUT -</i>	DC power supply output to power amplifier enclosure
<i>AC ON/OFF -</i>	AC rocker switch (SPST) to supply AC to the AC-DC Switching power supply.

Initial Hook Up

1. Ensure that the antenna has been swept and has a return loss of greater than 20dB (VSWR = 1.2:1). This should be done before connecting the antenna cable to the transmitter output.
2. Check that your video source is present.
3. Place the transmitter/translator in its permanent location near a receptacle supplying required AC voltage.

DO NOT APPLY AC POWER AND TURN ON POWER TO THE TRANSMITTER /
TRANSLATOR AT THIS TIME SINCE THE RF OUTPUT MUST BE PROPERLY
LOADED BEFORE OPERATION.

4. Place an appropriate AC power line protector, conditioner, and/or surge suppressor across the AC supply line.
5. Hook up the modulator or processor as shown in their respective manuals for a transmitter or translator. **Do not** connect the modulated signal from the RF OUT on the modulator or processor to RF IN on the power amplifier at this time. Because of the characteristics of LDMOS devices, the RF drive should not be connected to the power amplifier until after the power supply and bias voltages are present and stable.
6. Ensure that modulator or processor RF output level is turned down as far as possible.
7. Ensure that the audio modulation is set to 100% with the audio signal supplied, as described in the appropriate modulator/processor manual (will be factory set).
8. Ensure that the video modulation level is set to 87.5% with the video signal supplied, as described in the appropriate modulator/processor manual (will be factory set).
9. Install the DC power supply leads (4 AWG) between the power supply enclosure and power amplifier enclosure.
10. Connect the transmitting antenna cable to the RF OUT N-type connector on the PA enclosure RF output.

Section IX - Operating Procedure

Assuming the previous installation instructions have been completed and cautions noted, and the TAU-500 power amplifier is ready to receive a properly modulated video and audio signal, proceed with the following steps to place the system in operation. The TAU-500 power amplifier has been factory aligned for channel frequency (per system specification), signal levels and optimum performance.

IT IS HIGHLY RECOMMENDED THAT YOU RUN YOUR SYSTEM INTO A DUMMY LOAD BEFORE INSTALLING TO MAKE SURE THERE ARE NO DAMAGES CAUSED IN SHIPPING AND THE UNIT IS RUNNING PROPERLY

1. Do not apply RF drive signal to the power amplifier at this time.
2. Verify that all control and RF cables are tight and properly seated in or on the mating connector.
3. Plug the modulator or processor into AC mains.
4. With the PA output loaded, plug the 5U power supply enclosure into 220V AC mains.
5. Switch AC rocker switch to "ON" position.
6. Verify that the power amplifier fans are all on.
7. Ensure that the modulator/processor is turned on and set up according to its instructions. Depress the POWER tactile button to turn the unit on.
8. The internal soft start circuitry will turn the bias voltages off until the power supply to the amplifier pallets is fully stable. The message on the LCD indicates when the soft start is running. Once complete, the Forward and Reflected Power and Power Supply readings will appear on the LCD in the filter and power amplifier enclosures.
9. After the soft start is complete, apply the RF drive signal (which still should be turned down) between the modulator or processor and the power amplifier RF In. This ensures that the RF drive signal is applied only after the power supply is stable and the bias voltages are applied to the amplifier.

10. The TAU-500 LCDs show the user the present status of the amplifiers. Adjust RF output power to desired level (see Important RF Power Notice in previous section). Verify that the FWD Power reads 400 to 500 Watts on the PA enclosure - depending on the modulation of the signal content. The system is set up for 500 watts peak visual power using the sync and blanking signal and should read 500 watts FWD Power on the LCD **under this condition only**. The output power level can be adjusted using the modulator or processor's RF output level adjust. Keep in mind that the system will shut down should the forward RF output power level be exceeded.
11. Ideally, the RFL Power should read zero. However, should a high VSWR be detected, the system will automatically shut down and cycle as previously described. This is also a peak wattage reading.
12. Verify that the power supply reads approximately 30 Volts DC (see supplied final inspection sheet for factory settings of power supply levels) on the LCD of the power amplifier.
13. Look at the transmitted output using a suitable monitor. The picture and sound quality should be clean and sharp. If the output picture and sound quality is unsatisfactory, check the input signals, connections to the antenna system, antenna and transmission line VSWR, and the physical condition of the antenna.

If reception problems are encountered, and the quality of transmission is satisfactory, the difficulty is often with the receiving antenna or with obstructions in the path between the transmitter/translator and receiver.

Section X – Maintenance and Troubleshooting

Periodic Maintenance

If your unit employs a filter on the air inlet for the fans, the filter should be cleaned every 30 days. If the equipment is operated in a severe dust environment, the filters on the inlet fan may need to be cleaned more regularly. *Turn the system off and unplug all of the AC inlet cords.* The filter can be lifted off the fan and cleaned using an air compressor at low pressure. While the filter is out, clean the fan blades themselves with a small brush. The fans themselves do not need lubrication.

The interior of the cabinets should be cleaned and inspected annually. *Turn the system off and unplug all of the AC inlet cords.* Remove the top lid by unscrewing the 6-32 machine screws.

Use extreme caution when working near the AC input terminal. The power amplifier and power supply store hazardous capacitances and voltages.

Using either compressed air or a brush with soft bristles, loosen accumulated dust and dirt and then vacuum the interior of the cabinet. Complete a visual inspection of the interior, making sure there are no loose connections or discolorations on any components from heat. Nothing inside the power amplifier enclosure exceeds a temperature that is not comfortable to the touch under normal operating conditions, so any signs of discoloration indicate potential damage.

All modular components inside the enclosure are attached to aluminium mounting plates for easy removal and replacement. Ensure that plates are secured and the mounting hardware is tight.

Troubleshooting

The first and most important aspect of troubleshooting anything is to be systematic. Note where you have looked and what you found.

Look first for the obvious.

- Make a physical inspection of the entire facility. Are all necessary connections properly made? Do you see any signs of obvious damage within the equipment?
- Is the AC power 'ON' to the site and the equipment? (Check fuses and circuit breakers if necessary.)
- Are all the switches in the correct operating position?
- Is the input signal present?
- Check LCD readings for presence of forward and reflected power and 30 V DC supply levels.

The above is an aid in determining the fault if some aspect of the system is not operating. The following table deals with quality of operation:

Symptom	Possible Fault	Correction
Horizontal bars in picture (may roll either way depending on phase)	AC grounding / AC interference	Install EMI/RFI filter in AC line
		Ensure modulator/processor and power amplifier share a common ground
Diagonal lines in picture	Interference	Install EMI/RFI filter in AC line
		Determine source and frequency of interfering signal (spectrum analyzer may be required)

Symptom	Possible Fault	Correction
Weak output or picture	Low level input signal	Verify presence and level of input signal
	Low output power	Verify power amplifier output with wattmeter and dummy load
	Incorrect modulation depth	Adjust to meet specification
High reflected power	Incorrect load	Ensure amplifier connected to transmission line
		Ensure correct antenna impedance (50 ohms)
		Check antenna tuning and VSWR. Verify correct cable for transmission line length
		Check all cables for visible damage (kinks, nicks or cuts)
		Check all connectors for poor connections, water or corrosion
		Check alignment of antenna
		Check for physical damage of antenna, including ice build-up

**Thank you
for choosing
Technalogix Ltd.**