



TAV-25

POWER AMPLIFIER

**NEW
ADVENTURES
IN
BROADCASTING**

You've already unpacked it, haven't you? You've unpacked it and plugged it in and turned it on and fiddled with the knobs. No? Okay, good. Please take a few minutes to read the manual and familiarize yourself with your new Technalogix power amplifier.

We believe that this manual, and of course our equipment, should be everything you need to get on the air with superb broadcast quality video. We understand that a capable and confident user will get the most out of our product and we have made every attempt to educate readers of all technical levels. If there is something that is not clear, or you require further information, please do not hesitate to contact us and we'll be glad to help out.

Technalogix Ltd.
#4, 8021 Edgar Industrial Place
Red Deer, Alberta, Canada
T4P 3R3
Phone: 403.347.5400
Fax: 403.347.7444
URL: www.technalogix.ca
Email: technical@technalogix.ca
sales@technalogix.ca

We truly appreciate that you have chosen us as your television broadcast system supplier. Happy viewing.

Table of Contents

SECTION I- SAFEGUARDS	I-1
SAFETY AND FIRST AID.....	I-2
OPERATING SAFEGUARDS	I-3
SECTION II - WARRANTY	II-1
SECTION III - OVERVIEW	III-1
STANDARD FEATURES	III-1
PRINCIPLE OF OPERATION.....	III-2
BLOCK DIAGRAM.....	III-3
SPECIFICATIONS.....	III-5
SECTION IV - RF COMPONENTS	IV-1
AMPLIFIER PALLETS	IV-1
DIRECTIONAL COUPLER.....	IV-4
FILTER	IV-4
SECTION V - POWER SUPPLY SECTION	V-1
SECTION VI - MONITOR AND CONTROL SYSTEM	VI-1
CONTROL BOARD OVERVIEW (INSIGHT).....	VI-1
USER INTERFACE MODULE	VI-1
COUPLER CONDITIONING MODULE	VI-2
RF CONDITIONING MODULE	VI-3
TEMPERATURE SENSOR MODULE	VI-4
TXNET MODULE.....	VI-5
REMOTE PORT.....	VI-6
FAULT SHUTDOWN.....	VI-7
BILL OF MATERIALS	VI-8
SCHEMATICS	VI-10
SECTION VII - MECHANICAL SECTION	VII-1

SECTION VIII - INSTALLATION	VIII-1
BUILDING RECOMMENDATIONS.....	VIII-1
HEATING AND COOLING REQUIREMENTS	VIII-2
ELECTRICAL SERVICE RECOMMENDATIONS.....	VIII-3
ANTENNA AND TOWER RECOMMENDATIONS.....	VIII-4
SHELTER SECURITY	VIII-5
UNPACKING AND INSPECTION.....	VIII-6
LOCATION AND FUNCTION OF CONTROLS AND CONNECTORS (TXV-25 POWER AMPLIFIERS).....	VIII-7
INITIAL HOOK UP.....	VIII-11
SECTION IX - OPERATING PROCEDURE	IX-1
SECTION X - MAINTENANCE AND TROUBLESHOOTING	X-1
TRUBLESHOOTING	X-2

Section I - Safeguards

General Safeguards

This section is written as a general guide to keep all 5 fingers on your hand and is intended for those having previous knowledge and experience with these kinds of equipment. It is not intended to contain a complete statement of all safety precautions, which should be observed by personnel using this or other electronic equipment.



DOCUMENTATION - Read, retain and follow instructions before operating the equipment. There is a lot of useful information in the manual, and besides, we spent a lot of time writing it!



ENVIRONMENT - To reduce the risk of fire or electric shock, do not expose this equipment to rain, moisture, or rye and sodas at the company Christmas party. Refer all servicing to qualified service personnel.



SERVICING - Do not attempt to service this equipment yourself as opening or removing covers can result in a warm tingly feeling and will void the warranty. Refer all servicing to qualified service personnel.

Safety and First Aid

Personnel engaged in the installation, operation, maintenance, or servicing of electronic equipment are exposed to the hazard of high voltage. It is imperative that all safety regulations and precautions are consistently observed. Knowledge of first aid procedures is recommended. The following information is presented as a reference only.

- At all times, avoid placing any part of the body in series between ground and circuit points, whether power is on or off.
- Dangerous voltage may be present in equipment even though power is off. Do not open the cabinet. Refer servicing to qualified service personnel.
- It is the duty of all personnel to be prepared to give adequate emergency first aid treatment and thereby prevent avoidable loss of life.
- There are three principle degrees of burns, recognizable as follows:
 - a first-degree burn reddens the skin.
 - a second-degree burn blisters the skin.
 - a third degree burn chars the flesh and frequently places the victim in a state of shock accompanied by respiratory paralysis.
- Respiratory paralysis can cause death by suffocation within seconds. It is imperative that the approved methods of artificial respiration are initiated immediately and continue until the victim's breathing is normal.
- A muscular spasm of unconsciousness may render the victim unable to break free of the electric power. If this is the case, turn the power off immediately.

DO NOT TOUCH THE VICTIM OR YOU MAY SHARE THE SAME PREDICAMENT.

- If the power cannot be turned off immediately, very carefully loop a dry rope, article of clothing, length of strong cloth or a rolled-up newspaper around the victim and pull the victim free of the power source. Carefully avoid touching the victim or clothing.
- Once free of the power source, the victim must be placed in a reclining position and covered with a blanket or newspapers to keep warm. At the first opportunity, enlist help in summoning a doctor. If a doctor cannot be summoned, transport the victim to the doctor or a hospital. Be sure the victim is kept well covered and warm while awaiting professional treatment.

Operating Safeguards

It is a known fact that our broadcast transmitters and translators enjoy 50-ohm load impedances. So much so, that it is imperative you maintain 50-ohm impedances throughout your system. In return, your equipment will provide you with maximum power transfer to the antenna and decreased reflected power heading back towards the amplifier pallets, reducing the amount of magic smoke that gets let out of the power amplifier. Before anything is turned on, ensure that there is a 50-ohm path from the output of each stage to the input of the next, all the way to the antenna.

In addition to maintaining proper 50-ohm impedances throughout the signal chain, it is also important, whenever possible, to make sure the RF drive going to the input of the power amplifier is removed before turning on or turning off the DC power supply. This is because all of the RF transistors used in the individual amplifier pallets are fabricated with LDMOS (Laterally Diffused Metal Oxide Semiconductor) technology. Nice and linear yes, but they do not like to make any RF power when their supply voltages are not within a specific range. When you first turn your power amplifier on or off, the DC power supply's output voltage may take a while to stable out to a safe operating voltage. Ten seconds wait before applying the RF drive will ensure no issues arise.

Our power amplifiers are designed to reliably generate a specific RF output power. Failing to adhere to overdriven amplifier warnings can decrease the reliability of your system, and frankly, makes our repair department busy and grumpy. If you need to transmit to a little larger coverage, you are better off increasing antenna gain, and more importantly, antenna height above average terrain. On TV and FM broadcast frequencies, insufficient antenna height puts an upper limit on your range, regardless of power levels, as the distance from your antenna to the radio horizon is limited.

Section II - Warranty

Our legalese is straightforward. It is simply designed to give you peace of mind and helps you resist the temptation to have your electronics friend try to repair your Technalogix product.

Technalogix Ltd. products have been completely tested and found to meet specifications and be in proper operating condition. They are warranted to be free from defects in materials and workmanship for a period of one year from the date of shipment. If the system becomes damaged in shipment and there are obvious signs of damage to the outside of the packaging, notify your courier immediately before that courier walks out the door.

Technalogix Ltd. will not be liable for damages of whatever nature arising out of or in connection with the equipment or its use thereof. Technalogix does not assume responsibility for injury or damage resulting from the practices of untrained or unqualified personnel in the handling of this equipment.

Technalogix Ltd. warranty does not include:

- misuse, neglect or accident.
- incorrect wiring and /or improper installation.
- unauthorized repairs, modifications or use in violation of instructions issued by Technalogix.
- incidental or consequential damages as a result of any defect.
- reshipment cost or insurance of the unit or replacement units or parts.
- acts of nature or terrorism.

Technalogix agrees, at our option, to remedy warranted defects or furnish a new part in exchange for any part of a unit which, under normal installation, use and service, becomes defective. The user will pay for transportation costs to and from the repair center. If you require technical service on the site, the cost to you will be \$800.00 per day plus air fare and meals.

To claim your rights under this warranty:

- Contact Technalogix and describe the problem in as much detail as possible. See troubleshooting section in this manual. If a solution cannot be found at this time, it may be determined that the unit will have to be returned to Technalogix for repair, once a Return Materials Authorization (RMA) number is provided. Please look under our web site (www.technalogix.ca) for the RMA form (Service) and fill it out. Either fax it to us or email to us.
- Package equipment carefully for prepaid shipment to Technalogix. Include a written description of the problem experienced, a copy of the original invoice establishing warranty status, and the RMA.

Technalogix reserves the right to make revisions in current production of the equipment and assumes no obligation to incorporate these changes in earlier models.

Shipping Address:

Technalogix Ltd.
ATTN: RMA# _____
#4, 8021 Edgar Industrial Place
Red Deer, Alberta, Canada
T4P 3R3
Ph: 403.347.5400
Made in Canada, returned for repairs

Section III - Overview

Standard Features

- Narrow output bandpass filter allows adjacent channel operation
- Front panel Liquid Crystal Display (LCD) to monitor forward and reflected RF power, and DC voltage
- Microcontroller-based monitoring and control ensures amplifier will never be overdriven and high VSWR will not damage amplifier
- AC circuit breaker on back panel to eliminate replacement of fuses
 - RF/EMI filtering on AC entry plug
 - All aluminium enclosure maintains power amplifier's light weight
 - Simple design using commonly available parts ensures reliable operation
 - Predominate and third-order intermodulation distortion exceeds Industry Canada and FCC specification.

Principle of Operation

The TAV-25 power amplifier supplies a 25-watt peak video signal with an aural carrier level 10 to 13 dB below visual carrier (dBc) on any of the VHF television channels 2 through 13. Please note that channel selection must be made at time of order, as the transmitter or translator is calibrated and tested to the channel requested and is not field tuneable. The TAV-25 power amplifier is a modular solid-state 25-watt broadcast amplifier utilizing readily available RF components wherever possible, thus enhancing the serviceability of the equipment.

The TAV-25 is comprised of a VHFTV-25-L pallet for low-band VHF frequencies or VHFTV-25-H pallet for high-band VHF frequencies.

The TAV-25 features ultra linear amplification and individual channel RF output bandpass filtering. The amplifier modules are stable for high reliability and long service life.

Block Diagram

The RF signal enters through the RF Input connector on the power amplifier enclosure from the modulator or processor. It then passes through an RF attenuator to limit the output power level of the power amplifier and to help buffer any transients that may come into the power amplifier. After attenuation, the signal is amplified through the VHFTV-25 driver before the signal passes through a bandpass filter. Finally, the amplified signal passes through a dual directional coupler for monitoring purposes. After the directional coupler, the signal exits the power amplifier enclosure before heading out to an antenna for broadcast.

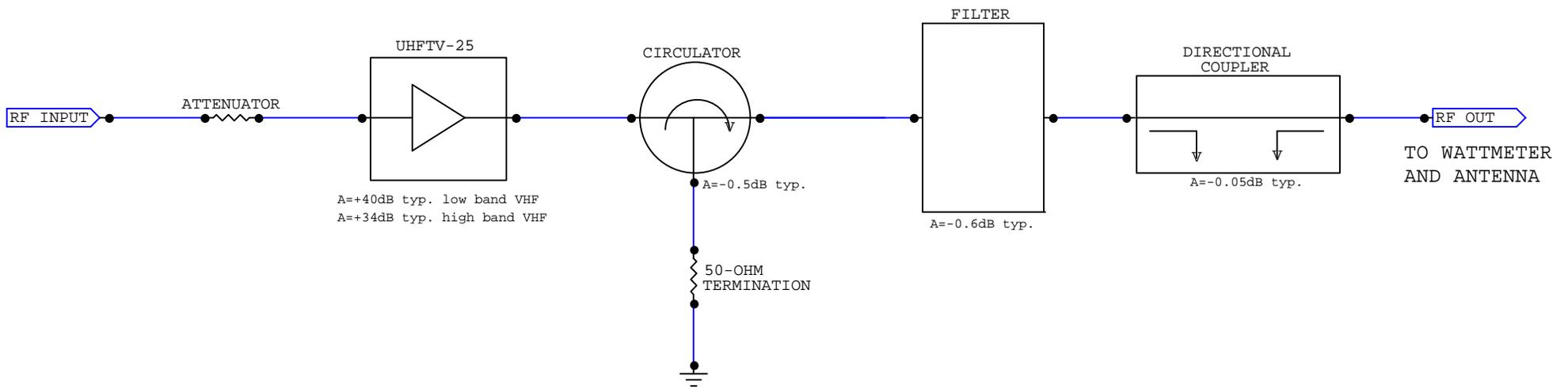

TAV-25 Block Diagram	
Rev	ID
Date: May 23, 2005	Page: 1 of 1

Specifications

The following specifications were taken with a Technalogix modulator/processor. Should a different modulator or processor be used, specifications could vary. For this reason, we recommend that any different modulator/processor be shipped to Technalogix so the system can be matched and set up optimally. In addition, the audio/video ratio the input to the power amplifier needs to be -10 dB in order for the software and LCD readout to be accurate.

RF Characteristics

Frequency range	any specified VHF Channel 2 to 13
Frequency Response (one channel)	±0.5 dB
Frequency Stability	±250 Hz
Selectivity	60 dB (adjacent channel)
Minimum Input Level	0 dBmV
Rated Visual Output Power	25 Watts
Rated Aural Output Power	10% of peak visual power
IF Output Level	+35 dBmV nominal
Input Impedance	75 Ohms
Output Impedance	50 Ohms
Harmonics	> 60 dB below rated power
Predominant Intermodulation Distortion	dBc = decibels below visual carrier
+ 920 kHz	> -53 dBc
- 920 kHz	> -53 dBc
+ 2.66 MHz	> -53 dBc
- 2.66 MHz	> -53 dBc
+ 5.42 MHz	> -53 dBc
+ 7.16 MHz	> -53 dBc
3 rd Order Intermodulation Distortion	
+ 4.5 MHz	> -60 dBc
+ 9.0 MHz	> -60 dBc
All others	> -60 dBc
Spurious Emissions	> -60 dBc

NTSC Video Characteristics

Input Level to modulator (for 87.5% modulation)	1.0 V _{PP}
Differential Phase (at 87.5% modulation)	±2 Degrees
Differential Gain (at 87.5% modulation)	2%
Group Delay	< ±40 nS
Video Group Delay Pre-emphasis	Conforms to IC/FCC specifications
K-Factor	1.9% for 2T Pulse
Hum and Noise	> 60 dB below rated power

Aural Characteristics

Input Level for 25 kHz Deviation	0.3 V _{PP}
Frequency Response (Standard Pre-emphasis)	±1 dB
Harmonic Distortion (25 kHz Deviation)	< 1% 50 Hz to 15 kHz
Amplitude Modulation Noise	> 50 dB
Frequency Modulation Noise	> 60 dB
Intercarrier Stability	±250 Hz

Physical Characteristics

Power Requirements	
TAV-25 Power Amplifier	115 V _{AC} , 4 A _{AC} or 230 V _{AC} , 2 A _{AC}
Operating Temperature	0 - 50 °C
Dimensions	
TAV-25 Power Amplifier	W-19" flange (17" incl.) , D-21.25", H-5.25" (3U)

Section IV – RF Components

Amplifier Pallets

The VHFTV-25 pallet is a two stage ultra linear class-A linear pallet. The VHFTV-25-L has a typical gain of 40dB and the VHF TV-25-H has a typical gain of 34dB. These pallets draw no more than 3.0A_{dc} total drain current (the exact bias and drain currents of your system are found in the spec sheet supplied with each manual). The quiescent and drain currents can be measured on the VHFTV-25 pallet by measuring the voltage drop across the current sense resistor found directly at the DC power supply lead input to the pallet. This resistance is 0.01-ohms, providing a 10mV per ampere ratio.

Each of the amplifier pallets is connectorized. All amplifier pallets must have the transistor drain voltages reach at least 26V_{dc} before the RF drive is applied.

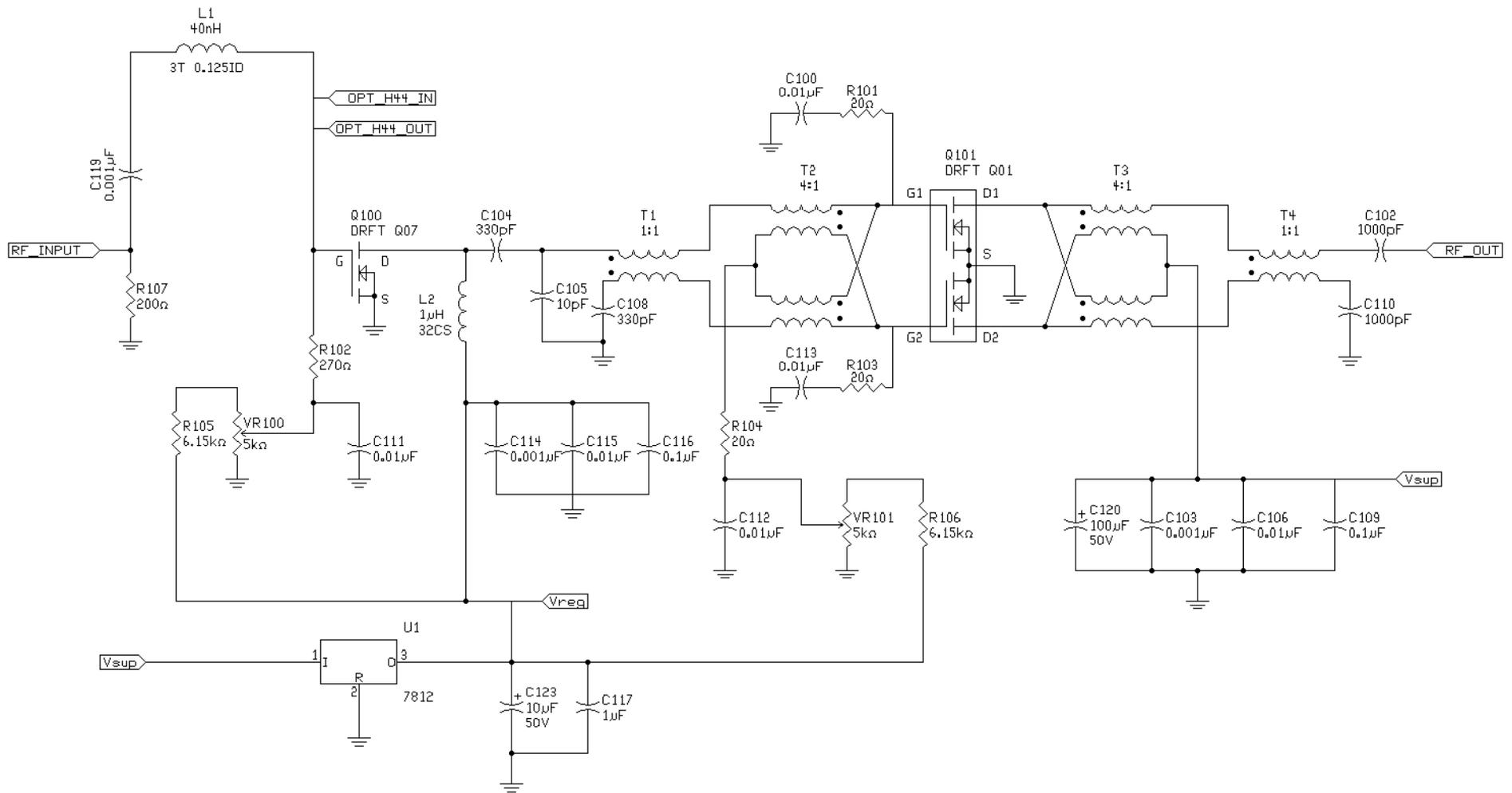

-H44 Option (+0dBm Input)

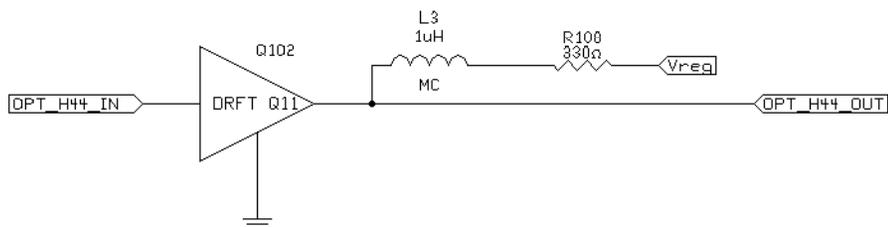

Co: TECHNALOGIX LTD.

Title: 25 W UHF HI BAND DRIVER

Board: P25-UHF

Revision: A

Author: R.S. MCDONALD

Size: A

Date: 14 SEPTEMBER, 2000

Sheet 1 of 1

Filter

The passive bandpass filter rejects spurious and harmonic output products and passes the VHF channel RF output. The cavity resonator uses aperture coupling and is a linear resonator design. Typical insertion loss is 0.6 dB to 1.0 dB depending on channel frequency. Average roll off is -33 dBc at a point 4.5 MHz below the peak visual carrier frequency and -30 dBc 9.0 MHz above the peak visual carrier frequency. The filter is DC grounded on both the input and output for additional lightning protection.

Directional Coupler

The Technalogix dual directional couplers provide DC voltages proportional to forward and reflected RF power monitoring. These analog voltages are converted for processing using analog-to-digital converters and provide the control system with valuable data for monitoring purposes. The directional couplers installed in the power amplifier and filter enclosures have peak detection circuits on the forward RF power side of the coupler and average detection circuits on the reflected RF power side of the coupler. This is to allow the end user to set power in a manner that is more independent of modulation and closer to a true tip-of-sync meter. Hence the readings of the displays in the power amplifier system are peak for forward and average for reflected. Output power should be set following the operating procedure found elsewhere in this manual. The directional coupler has a typical insertion loss of 0.5dB and its Type N connectors can handle 1,500 watts peak.

Section V – Power Supply

Switching AC-DC power supplies are used to power the amplifier pallets, the control circuits, and all of the fans. There is (1) power supply used to generate the necessary current for the amplifier pallets, set to 31.0 Vdc nominally.

The power supply is a Mean Well S-240-30. This switching power supply is fully protected against short circuit and output overload. Short circuit protection is a cycling type power limit. The internal AC fuse is designed to blow only on a catastrophic failure in the unit – the fuse does not blow on overload or short circuit. The thermal shutdown automatically recovers when the power supply chassis cools down.

AC is fed into the enclosure via a filtered EMI AC entry. It is then current limited with a resettable circuit breaker before passing through a rocker switch. This switch turns the AC on and off to the switching power supply.



■ Features :

- Auto switched 88 ~ 264VAC input
- Built-in passive PFC choke
- Protections: Short circuit/Over load/Over voltage/Over temperature
- Forced air cooling by built-in DC fan
- Built-in cooling Fan ON-OFF control
- LED indicator for power on
- Fixed switching frequency at 75KHz
- 2 years warranty



SPECIFICATION

MODEL	S-240-5	S-240-7.5	S-240-12	S-240-15	S-240-24	S-240-30	S-240-48	
OUTPUT	DC VOLTAGE	5V	7.5V	12V	15V	24V	30V	48V
	RATED CURRENT	40A	30A	18A	15A	10A	8A	5A
	CURRENT RANGE	0 ~ 40A	0 ~ 30A	0 ~ 18A	0 ~ 15A	0 ~ 10A	0 ~ 8A	0 ~ 5A
	RATED POWER	200W	225W	216W	225W	240W	240W	240W
	RIPPLE & NOISE (max.) Note.2	150mVp-p	200mVp-p	150mVp-p	150mVp-p	180mVp-p	180mVp-p	240mVp-p
	VOLTAGE ADJ. RANGE	4.5 ~ 5.8V	6 ~ 9V	10 ~ 14V	12 ~ 18V	20 ~ 28V	27 ~ 33V	41 ~ 56V
	VOLTAGE TOLERANCE Note.3	±2.0%	±2.0%	±1.0%	±1.0%	±1.0%	±1.0%	±1.0%
	LINE REGULATION	±0.5%	±0.5%	±0.5%	±0.5%	±0.5%	±0.5%	±1.0%
	LOAD REGULATION	±1.0%	±1.0%	±0.5%	±0.5%	±0.5%	±0.5%	±1.0%
	SETUP, RISE TIME	1000ms, 20ms at full load						
HOLD TIME (Typ.)	36ms at full load							
INPUT	VOLTAGE RANGE	88 ~ 132VAC / 176 ~ 264VAC auto switch						248~370VDC
	FREQUENCY RANGE	47 ~ 63Hz						
	EFFICIENCY (Typ.)	78%	80%	82%	83%	84%	85%	87%
	AC CURRENT (Typ.)	5A/115VAC		2.5A/230VAC				
	INRUSH CURRENT (Typ.)	15A/115VAC		30A/230VAC				
	LEAKAGE CURRENT	<2mA / 240VAC						
PROTECTION	OVER LOAD	105 ~ 135% rated output power Protection type : Hiccup mode, recovers automatically after fault condition is removed.						
	OVER VOLTAGE	6 ~ 7V	9.4 ~ 10.9V	14.4 ~ 16.8V	18.5 ~ 21.5V	31.2 ~ 36V	34.5 ~ 40.5V	57.6 ~ 67.2V
FUNCTION	FAN CONTROL, O.T.P.	RT1 ≥ 40°C FAN ON, ≤ 35°C FAN OFF, ≥ 70°C output shutdown						
ENVIRONMENT	WORKING TEMP.	-10 ~ +60°C (Refer to output load derating curve)						
	WORKING HUMIDITY	20 ~ 90% RH non-condensing						
	STORAGE TEMP., HUMIDITY	-20 ~ +85°C, 10 ~ 95% RH						
	TEMP. COEFFICIENT	±0.03%/°C (0 ~ 50°C)						
	VIBRATION	10 ~ 500Hz, 2G 10min./1cycle, 60min. each along X, Y, Z axes						
SAFETY & EMC (Note 4)	SAFETY STANDARDS	UL60950-1, TUV EN60950-1 Approved (7.5V Design refer to TUV EN60950-1)						
	WITHSTAND VOLTAGE	I/P-O/P:3KVAC		I/P-FG:1.5KVAC		O/P-FG:0.5KVAC		
	ISOLATION RESISTANCE	I/P-O/P, I/P-FG, O/P-FG:100M Ohms/500VDC						
	EMI CONDUCTION & RADIATION	Compliance to EN55022 (CISPR22) Class B						
	HARMONIC CURRENT	Compliance to EN61000-3-2,-3						
	EMS IMMUNITY	Compliance to EN61000-4-2,3,4,5,6,8,11; ENV50204, Light industry level, criteria A						
OTHERS	MTBF	179.3K hrs min. MIL-HDBK-217F (25°C)						
	DIMENSION	190*93*65mm (L*W*H)						
	PACKING	1.2Kg; 12pcs/15.3Kg/0.78CUFT						
NOTE	<p>1. All parameters NOT specially mentioned are measured at 230VAC input, rated load and 25°C of ambient temperature.</p> <p>2. Ripple & noise are measured at 20MHz of bandwidth by using a 12" twisted pair-wire terminated with a 0.1uf & 47uf parallel capacitor.</p> <p>3. Tolerance : includes set up tolerance, line regulation and load regulation.</p> <p>4. The power supply is considered a component which will be installed into a final equipment. The final equipment must be re-confirmed that it still meets EMC directives.</p>							

Section VI – Monitor and Control System

Control System Overview (Insight)

The Insight control system is used for a variety of functions, the most important of which is ensuring that the transmitter continues to operate in a safe manner. The control system also allows the user to monitor and control the transmitter from both the front panel and the remote access port.

Five modules comprise the Insight control system. These modules work together to provide all the functions of the control system. The modules are: the user interface module, the coupler condition module, the RF conditioning module, the temperature sensor module, and the TxNET module. The operation of each module is outlined in the following sections.

User Interface Module

The primary function of the user interface module is, as the name suggests, providing the user interface for the control system. This circuit board is mounted to the front panel of the transmitter, directly behind the LCD display. The membrane switch on the front panel is also connected to the user interface module. These components together provide the user with the ability to monitor the transmitter from the front panel.

The following parameters can be monitored from the front panel:

- Forward (incident) power at the transmitter output.
- Reflected (reverse) power at the transmitter output.
- DC voltage of the transmitter power supply.
- DC current for each pallet in the transmitter.
- Temperature of the heat sink of the transmitter.
- The time since the transmitter was last shut down.

The hardware of the user interface module is based around a microcontroller (U112). This microcontroller interfaces directly with the LCD and the membrane switch to provide output and receive input from the user. The microcontroller also communicates with the coupler conditioning board over a controller area network (CAN) bus. This communication is facilitated by two ICs, U113 and U114, and passes through a CAT5 cable attached to connector J105. The communication link with the coupler conditioning module allows the user interface module to receive information about the forward power, reflected power, and temperature of the transmitter, as well as relay commands from the user to the rest of the system. If the transmitter includes more than one amplifier module, a second CAN connection will be present between the user interface module (J106) and the TxNET board to facilitate communication between enclosures.

Other elements of the user interface module are also controlled by the microcontroller. A buzzer (BZ101), a status LED (D113), and a relay to control the backlight of the LCD (RL101), are all controlled through a buffer (U116). In order for the user interface module to monitor the current draw of each pallet in the system, the DC supply wires pass through the user interface module on their way from the power supply to the pallets. The DC enters through connector J101 from the power supply, and exits through J102 to go to the pallets. As the current passes through shunt resistors (R117, R118, R120, R121, R123, R124, R126, R127, R129, R130), the voltage drop is

monitored by U101 to U105, buffered by U106 to U108, and sent to the analog to digital converter integrated into the microcontroller. There are five circuits for which the current is monitored by this system.

As the DC supply passes through the user interface module, it undergoes filtering to ensure that the supply to the pallets is as clean as possible. Each of the five circuits passes through a network of transient voltage suppressors, capacitors, and inductors. Each connection is also fused at the input to insure an over-current condition does not persist. The fuses are a replaceable mini blade type fuse with a 42V voltage rating, and a current rating depending on application.

Coupler Conditioning Module

The coupler conditioning module serves to monitor the output of the directional coupler which provides a voltage proportional to the forward and reflected power at the output of the transmitter. The coupler conditioning module also interfaces with each of the other boards in the control system, acting as the hub of communications for the system. Lastly, the coupler conditioning board sends and receives signals through the remote access port, via the TxNET board.

The analog signals produced by the coupler for forward and reflected power are passed onto the coupler conditioning module by connectors J206 and J207 respectively. Each signal is filtered by CLC networks, and buffered and amplified by the op-amp U214. The level of the forward signal can be adjusted by VR201, and the reflected signal by VR202. These two potentiometers can be used to fine tune the power readings of the transmitter if they go out of calibration. The analog signals are converted to digital by an analog-to-digital converter integrated into the microcontroller U202.

Aside from taking readings from the coupler, the microcontroller on the coupler conditioning module also interfaces with the RF conditioning module (through J201A) and the temperature sensor (through J201B). The microcontroller interfaces with the CAN bus using U203 and U204. Through the CAN bus, the coupler conditioning board is able to communicate with the user interface module, and any other amplifiers that are in the system. The CAN bus is connected through J201C, and J201D if there are multiple amplifiers in the transmitter system.

The last task of the coupler conditioning board is to send and receive remote access signals to and from the TxNET board. Two analog outputs, proportional to forward and reflected power and produced by the digital-to-analog converter U212 after it receives input from the microcontroller. The analog outputs are then buffered by U211 before being sent through J203 to the TxNET board. J203, along with J204, also bring the digital inputs and outputs from the TxNET board to the coupler conditioning module. The digital signals are then connected to the microcontroller through the opto-isolators U205, U206, U207, U208, and U209.

RF Conditioning Module

The RF conditioning board is located at the RF input of the amplifier. Its main function is to act as a variable attenuator, so that the control system can add attenuation to the input of the amplifier in order to limit the output power of the transmitter. The RF signal comes in to the RF conditioning module through J302 before it passes through a manually variable attenuator made up of R305, VR303, and R307. The signal then passes through the digitally-controlled variable attenuator U302 before exiting through J303. The input for the digital attenuator comes from the coupler conditioning module through J304. The input signals are passed through the opto-isolators U303, U304, and U305 before being sent to the digital attenuator. In total, five control signals go to the digital attenuator, allowing for attenuations of up to 31dB in 1dB steps.

Temperature Sensor Module

The temperature sensor module is a small board mounted to the main heatsink of the amplifier. The main purpose of the temperature sensor module is to take temperature readings of the heatsink. The temperature sensor IC is U1 which, after it has taken a reading, relays the digital information to the coupler conditioning module through J1. Also passing through J1 is a driver disable signal coming from the coupler conditioning module. The temperature sensor module simply takes this signal and passes it through to J2, where it is connected to the driver pallet.

TxNET module

The TxNET module is simply a passive board that acts as an interface between the wiring on the inside of the amplifier enclosure and connections on the outside of the enclosure. The DB-25 connector for the remote port (J602) is attached to the TxNET module. The signals travelling through this port are connected to the coupler conditioning module through J601 and J603. The TxNET module also includes up to four straight through RJ45 connections: J604 to J605, J606 to J607, J608 to J609, and J610 to J611. These connections are only used on systems with multiple enclosures, to pass control signals between enclosures.

Remote Port

The remote port allows external control of the transmission system via the DB25. The functions of each pin on the remote port are indicated in the following table:

Pin Number	Description
1	Ground
2	Forward power sample ¹
3	Reflected power sample ¹
4	Carrier off ²
5	Carrier on ²
6	Increase carrier level (level must have been decreased) ²
7	Decrease carrier level (1dB increments) ²
8	Soft reset ²
9	Reset ²
10	Power supply fault flag ³
11	High temperature flag ³
12	High VSWR flag ³
13	Amplifier overdriven flag ³
14	+5Vdc
15	+3.3Vdc
16	Ground
17	Ground
18	N/C
19	N/C
20	N/C
21	N/C
22	N/C
23	N/C
24	N/C
25	N/C

Notes: 1. Analog output with voltage ranging from 0 to 5Vdc.
2. TTL level digital input, active on rising edge.
3. TTL level digital output, active high.

Fault Shutdowns

On the LCD (Liquid Crystal Display) the following messages may appear:



If you see this message, the system has been driven to a power level higher than it is rated for. This message will likely only appear momentarily, before the amplifier will add attenuation at its input to bring the output power to a safe level.



This message indicates that excessive reflected power has been detected at the output of the transmitter. Periodically, the amplifier will cycle on, and re-check for reflected power. If high reflected power continues, the transmitter will eventually shut down completely.



This message indicates that the transmitter is experiencing unsafe internal temperatures. Output power is reduced until a safe temperature is reached.

Monitor and Control System (Insight) Bills of Materials

Circuit: User Interface Module
Revision: 1.03

Designations	Qty	Description	Package	Manufacturer	Mfg. Part Number
U112	1	IC MICROCONTROLLER 256 BYTE RAM	64QFP	Texas Instruments	MSP430F135IPM
C106, C107, C117, C118, C128, C129, C141, C142, C148, C149, C163	11	CAPACITOR 0.01 uF 50V 10%	0805	Yageo	08052R103K9B20D
C108-116, C119-127, C130-140, C143-145, C161	33	CAPACITOR 0.1uF 50V 10%	0805	Yageo	08052R104K8B20D
C146, C147	2	CAPACITOR 33pF 50V 5%	0805	Panasonic	ECJ-2VC1H330J
R101, R104, R107 R110, R113	5	RESISTOR 2.7K?	0805	Yageo	9C08052A2701FKHFT
C162	1	CAPACITOR 1uF, 50V	0805	TDK Corporation	C2012Y5V1H105Z
R132	1	RESISTOR 37.4K?	0805	Yageo	9C08052A3742FKHFT
R133	1	RESISTOR 3.3K?	0805	Yageo	9C08052A3301FKHFT
R134, R135, R136, R137, R138, R139	6	RESISTOR 249K?	0805	Yageo	9C08052A2493FKHFT
R140, R141, R144 R145, R146, R147 R150, R151, R156	9	RESISTOR 10K?	0805	Yageo	9C08052A1002FKHFT
R142, R143, R148 R149, R154, R155	6	RESISTOR 1K?	0805	Yageo	9C08052A1001FKHFT
R152	1	RESISTOR 100?	0805	Yageo	9C08052A1000FKHFT
R119, R122, R125, R128, R131, R153	6	RESISTOR 100K?	0805	Yageo	9C08052A1003FKHFT
R158	1	RESISTOR 430?	0805	Yageo	9C08052A4300FKHFT
R160	1	RESISTOR 1.4K?	0805	Yageo	9C08052A1401FKHFT
R161	1	RESISTOR 27K?	0805	Yageo	9C08052A2702FKHFT
R162	1	RESISTOR 6.2K?	0805	Yageo	9C08052A6201FKHFT
R157	1	RESISTOR 4.7?	2010	Panasonic	ERJ-12ZYJ4R7U
R117, R118, R120 R121, R123, R124 R126, R127, R129 R130	10	RESISTOR 0.006? 1% 1W	2512	Vishay	WSL25126L000FEA
R159	1	POTENTIOMETER 10K?	4mm SMD	Bourns	3314G-1-103E
R102, R103, R105 R106, R108, R109 R111, R112, R114 R115	10	RESISTOR 20? 1W	2512	Panasonic	ERJ-1TYJ200U
RN101	1	RESISTOR NETWORK 10K?	SMT	Panasonic	EXB-A10P103J
F107	1	RESETTABLE FUSE, POLYFUSE, 2A	SMD	Raychem	MINISMDC200-2
F108	1	RESETTABLE FUSE, POLYFUSE, .5A	SMD	Raychem	MINISMDC050-2

L106, L107, L108, L109, L110 Y101	5 1	INDUCTOR 0.01uH 6.00 MHz CRYSTAL	1210 SMT	TDK Citizen	NLV32T-010J-PF HCM49-6.00
U111	1	IC SUPERVISOR 2.70V LOW	SOT23	Microchip Technology	MCP130T-270I/TT
U114	1	IC TXRX 3.3V CAN	8-SOIC	Texas Instruments	SN65HVD232D
U113	1	IC CAN CONTROLLER W/SPI	18-SOIC	Microchip Technology	MCP2510-I/SO
U115	1	IC REG SIMPLE SWITCHER	TO-263-5	National Semiconductor	LM2576HVS-5.0
U116	1	IC DARL TRANS ARRAY	16-SOIC	Texas Instruments	ULN2003ADR
U117	1	IC REG LINEAR LDO	SOT223	National Semiconductor	LM1117MP-3.3
U118	1	IC VOLTAGE COMVERTER	8-SOIC	National Semiconductor	LM2660M
U109, U110	2	OPTOCOUPLER DUAL CHANNEL	8-SOIC	Fairchild Semiconductor	MOCD211M
U101, U102, U103 U104, U105	5	IC CURRENT MONITOR	SOT23-5	Texas Instruments	INA168NA
U106, U107, U108	3	IC OP AMP SINGLE SUPPLY	8-SOIC	Texas Instruments	OPA2340UA
D101, D103, D105 D107, D109, D111	6	DIODE TVS 30V	D0214AA	Crydom	SMBJ30A
D102, D104, D106 D108, D110 D113, D115, D117	8	DIODE LED GREEN	1206	Lumex	SML-LX1206GC-TR
D114	1	DIODE SCHOTTKY	SMC	International Rectifier	30BQ060
D116	1	DIODE RECTIFIER 1A 200V	SMA	Diodes Inc.	S1D-13
D118	1	DIODE SCHOTTKY 5A 50V	SMC	Diodes Inc.	B550C-13 or B550C-13F
C152	1	CAPACITOR 10uF 16V TANTALUM	3528	Kemet	T491B106K016AS
C156-160	5	CAPACITOR 22uF 35V TANTALUM	D (SMT)	Kemet	T495D226K035ASE300
S101	1	SWITCH DIP 7 POSITION	SMT 0.1"	CTS	219-7MST
S102	1	HEADER 3POS 0.1"	Through Hole	AMP/Tyco	640452-3
RL101	1	RELAY SPST 5VDC	SMT	Omron	G6L-1F-DC5
L101, L102, L103, L104, L105	5	INDUCTOR 1.3uH	SMT	Panasonic	ETQ-P6F1R3LFA
C153, C154, C155	3	CAPACITOR 100uF, 10V	D (SMT)	Panasonic	ECE-V1AA101SP
U119	1	IC REG SIMPLE SWITCHER	TO-263-7	Texas Instruments	LM2679S-ADJ
C101, C102, C103, C104, C105, C150	6	CAPACITOR 100uF 63V	G (SMT)	Panasonic	ECE-V1JA101P
BZ101	1	BUZZER	SMT	CUI Inc.	CT-1205C
J107	1	CONNECTOR 14POS HEADER	Through Hole	AMP/Tyco	103308-2
J108	1	CONNECTOR SCREW TERMINAL	Through Hole	Keystone	7701
J105, J106	2	CONNECTOR MODULAR JACK 8 VERTICAL	Through Hole	AMP/Tyco	5556416-1
F101, F102, F103, F104, F105, F106	6	FUSE AND FUSE HOLDER 42V MINI	Through Hole	Littelfuse	02970xx.WXNV and 01530008Z
J103	1	CONNECTOR 5POS HEADER	Through Hole	AMP/Tyco	3-644695-5
J102	1	CONNECTOR, 2 PART 0.3" 10POS	Through Hole	Weiland	25.390.4053.0
J101	1	CONNECTOR 2 PART 0.3" 6POS	Through Hole	Weiland	25.390.3653.0
L111	1	INDUCTOR 150uH	S6	Talema	SWS-2.0-150
L112	1	INDUCTOR 33uH 5A 260kHz	Through Hole	Pulse	P0849NL
J104	1	16 POST HEADER	Through Hole	Samtec	TSW-116-18-T-S
C151	1	CAPACITOR 1000uF, 10V	G (SMT)	Panasonic	ECE-V1AA102P

Circuit: Coupler Conditioning
Revision: 1.04

Designations	Qty	Description	Package	Manufacturer	Mfg. Part Number
C201, C203, C204, C205, C208, C209, C212, C213, C214, C215, C216, C217, C218, C219, C220, C221, C222, C223, C224, C225, C226, C227, C228, C229	24	Capacitor, ceramic, 0.01uF, 50Vdc, +/-20%	SMD 0805	Kemet	C0805C103K5RACTU
C202	1	Capacitor, ceramic, 0.1uF, 50Vdc, +/-20%	SMD 0805	Yageo America	C0805C104M5UACTU
C206, C207	2	Capacitor, ceramic, 33pF, 50Vdc, 5%	SMD 0805	Panasonic	ECJ-2VC1H330J
C210, C211	2	Capacitor, electrolytic, 100uF, 10V, +/-20%	SMD 'D'	Panasonic	ECE-V1AA101SP
D201, D202	2	Diode, TVS, 5.0Vdc, 600W, unidirectional	SMB	General Semiconductor	SMBJ5.0A-13
D203, D204	2	Diode, LED, red, 2.0V	SMD 1206	Lumex	SML-LX1206IW-TR
D205	1	Diode, rectifier, 200V, 1A	SMA	Diodes Inc.	S1D-13
D206	1	Diode, zener, dual, 10V	SOT-23	Diodes Inc.	AZ23C10-7-F
J201	1	Connector, modular, female, 4-port, 8-position, rt. angle	Through Hole	AMP/Tyco	557562-1
J202	1	Connector, header, IDC, 0.1" spacing, 14-pos	Through Hole	AMP/Tyco	103308-2
J203, J204	2	Connector, modular, female, 8-position, vertical	Through Hole	AMP/Tyco	5556416-1
J205	1	Connector, header, 3-position, 0.1", square post	Through Hole	AMP/Tyco	644695-3
J206, J207	2	Connector, header, vertical, 3-pos, 0.1" spacing	Through Hole	Molex	22-02-2035
K201	1	Relay, SPST, 5Vdc coil, SMT	SMT	Omron	G6L-1F-DC5
L201, L202, L203, L204, L205, L206, L207, L208, L209, L210, L211, L212	12	Inductor, 0.01uH, I _{max} =0.45A, DCR=0.13 omhs	SMD 1210	KOA	KL32TE010K
R201	1	Resistor, thick film, 5%, 100ohm, 1/8W	SMD 0805	Panasonic	ERJ-6GEYJ101V
R203, R204, R207, R208, R211, R212, R213, R214, R217, R218, R219, R220, R221, R222, R223, R224	16	Resistor, thick film, 5%, 1kohm, 1/8W	SMD 0805	Panasonic	ERJ-6GEYJ102V
R205, R206, R209, R210, R215, R216	6	Resistor, thick film, 5%, 10kohm, 1/8W	SMD 0805	Panasonic	ERJ-6GEYJ103V
RN201, RN202, RN204	3	Resistor network, 10kohm, 8-resistors, 10-terminations, bussed, 5%	SMD 2512	Panasonic	EXB-A10P103J
RN203	1	Resistor network, 1kohm, 8-resistors, 10-terminations, bussed, 5%	SMD 2512	Panasonic	EXB-A10P102J
S201	1	Switch, DIP, 7-position, SPST	SMD 0.1"	CTS	219-7MST
U201	1	IC, supervisor, 2.7V, internal pull-up resistor, open drain, active low	SOT-23	Microchip Technology	MCP130T-270I/TT

U202	1	IC, microcontroller, 16-bit, 16k X 8 program, 48 I/O, flash	64-QFP	Texas Instruments	MSP430F135IPM
U203	1	IC, CAN transceiver, 3.3V	SOIC-8	Texas Instruments	SN65HVD232D
U204	1	IC, CAN controller, industrial temp, 3 transmit buffers, 2 receive buffers	18-SOIC	Microchip Technology	MCP2510-I/S0
U205, U206, U207, U208, U209	5	IC, optoisolator, dual, transistor o/p, Vceo=30V	SOIC-8	Fairchild	MOCD211M
U210	1	IC, buffer, Darlington, array	SOIC-16	Texas Instruments	ULN2003ADR
U211, U214	2	IC, op-amp, dual, single supply	SOIC-8	Texas Instruments	OPA2340UA
U212	1	IC, DAC, dual, 8-bit, serial	SOIC-8	Texas Instruments	TLV5625CD
U213	1	IC, voltage reference, 2.50V, +/- 0.2%	SOT-23	National Semiconductor	LM4040BIM3-2.5
VR201, VR202	2	Potentiometer, 2kohm, 11-turn, 5mm, top	SMT	Murata	PVG5A202C01R00
Y201	1	Crystal, 6.000MHz	SMT	Citizen	HCM49-6.00

Circuit: RF Conditioning
Revision: 1.05

Designations	Qty	Description	Package	Manufacturer	Mfg. Part Number
C301, C306, C311	3	Capacitor, ceramic, 0.1uF, 50Vdc, +/-20%	SMD 0805	Yageo America	C0805C104M5UACTU
C302, C303, C305, C312, C320	5	Capacitor, ceramic, 0.01uF, 50Vdc, +/-20%	SMD 0805	Kemet	C0805C103M5RACTU
C304	1	Capacitor, ceramic, 0.022uF, 50Vdc, +/-10%	SMD 0805	Panasonic	ECJ-2VB1H223K
C307, C308, C310	3	Capacitor, ceramic, 1000pF, 50Vdc, +/-10%	SMD 0805	Kemet	C0805C102K5RACTU
C309	1	Capacitor, ceramic, 330pF, 50Vdc, +/-10%	SMD 0805	Panasonic	ECJ-2VC1H331J
C313, C314, C315, C316, C317, C318, C319	4	DNS	SMD 0805		
D301	1	Diode, TVS, 30V, 600W	SMB	Diodes Inc.	SMBJ30A-13
D302	1	Diode, LED, green, Vf=2.2V	SMD 1206	Lumex	SML-LX1206GW-TR
D303, D304, D305, D306, D307	5	Diode, LED, red, Vf=2.0V	SMD 1206	Lumex	SML-LX1206IW-TR
D308	1	Diode, ultrafast	SOT-23	Fairchild Semiconductor	MMBD914
D309, D310	2	DNS	TO-92		
F301	1	Fuse, resettable, miniSMD, Ihold = 0.14A, Itrip = 0.34A	Fuse-miniSMD	Littelfuse	MINISMD014-2
J301	1	Connector, terminal block, header, 2-position, straight	PCB THT (0.2")	Wieland	25.350.3253.0
J301	1	Connector, terminal block, plug, 2-position, straight	-	Wieland	25.340.3253.0
J302, J303	2	Connector, SMA, PCB End Launch, 50-ohms	PCB End Launch	Johnson Components	142-0701-801
J304	1	Connector, modular, female, 8-position, vertical	PCB THT	Amp (Tyco)	5556416-1
L301	1	Inductor, 0.01uH	1210	TDK	NLV32T-010J-PF
PCB301	1	Printed circuit board, FR4, proto 2 or equivalent	-	Alberta Printed Circuits	PCB301

R301	1	Resistor, thick film, 5%, 620ohm, 1W	SMD 2512	Panasonic	ERJ-1TYJ621U
R302, R303	2	DNS			
R304, R312, R313, R318, R319, R322	6	Resistor, thick film, 5%, 1.0kohm, 1/8W	SMD 0805	Yageo America	9C08052A1001JLHFT
R305, R307	2	Resistor, thick film, 1%, 130ohm, 1/8W	SMD 0805	Yageo America	9C08052A1300FKHFT
R308, R309, R314, R315, R320	5	Resistor, thick film, 5%, 1.2kohm, 1/8W	SMD 0805	Yageo America	9C08052A1201JLHFT
R310, R311, R316, R317, R321	5	Resistor, thick film, 5%, 10kohm, 1/8W	SMD 0805	Panasonic	9C08052A1002JLHFT
R323	1	Resistor, 100ohm, 1/8W	SMD 0805	Yageo America	9C08052A1000FKHFT
R324	1	Resistor, 3.3ohm, 1/8W	SMD 0805	Yageo America	9C08052A3R32FGHFT
R325, R326, R327, R328, R329	5	DNS	SMD 0805		
VR301	1	Potentiometer, 5kohm	SMD 5MM	Murata	PVG5A502C01R00
VR302	1	DNS	SMD 5MM		
VR303	1	Potentiometer, 200ohm	SMT 5MM	Murata	PVG5A201C01R00
S301	1	Switch, DIP, 5-position, SPST, gold finish, sealed	CTS 219-5 SMD	CTS Corporation	219-5MST
U301	1	IC, voltage regulator, 5V output, 500mA	TO-252	National Semiconductor	LM78M05CDT
U302	1	IC, digital attenuator, 5-bit, 1dB LSB	SSOP-20	Skyworks (Alpha)	AA110-85
U303, U304, U305	3	IC, optoisolator, dual, transistor o/p, Vceo=30V	SOIC-8	Fairchild	MOCD211M
U306	1	Directional coupler		Mini-Circuits	DBTC-20-4
U307	1	IC, power detector	TSSOP-16	Analog Devices	AD8362ARU
U308	1	DNS (replace with two 0805 0ohm resistors)			
U309	1	DNS	TO-243		

Circuit: Temperature Sensor
Revision: 1.02

Designations	Qty	Description	Package	Manufacturer	Mfg. Part Number
C701	1	CAPACITOR 0.1uF 50V 10%	0805	Yageo	08052R104K8B20D
J701	1	CONN MOD JACK 8-8 R/A PCB 50AU	SMT	Molex	44144-0003
J702	1	TERMINAL SCREW VERTICAL	PC MNT	Keystone	8191
U701	1	IC DIG TEMPERATURE SENSOR	8-MSOP	National Semiconductor	LM70CIMM-3

Circuit: TxNet
Revision: 1.02

Designations	Qty	Description	Package	Manufacturer	Mfg. Part Number
F601, F602, F603, F604	4	Fuse, resettable, Ihold=0.14A, Itrip=0.34A, Vmax=60V	SMD	Tyco	MINISMDC014-2

J601, J603, J604, J605, J606, J607, J608, J609, J610, J611	10	Connector, modular, jack, 8- position, vertical, PCB mount		Tyco	5556416-1
J602	1	Connector, D-sub, 25 position, female, vertical, PCB mount		Kycon	K85-BD-25S-R

Insight System Schematics

The following pages contain the schematics for the Insight system.

User Interface Module

DC Supply Conditioning

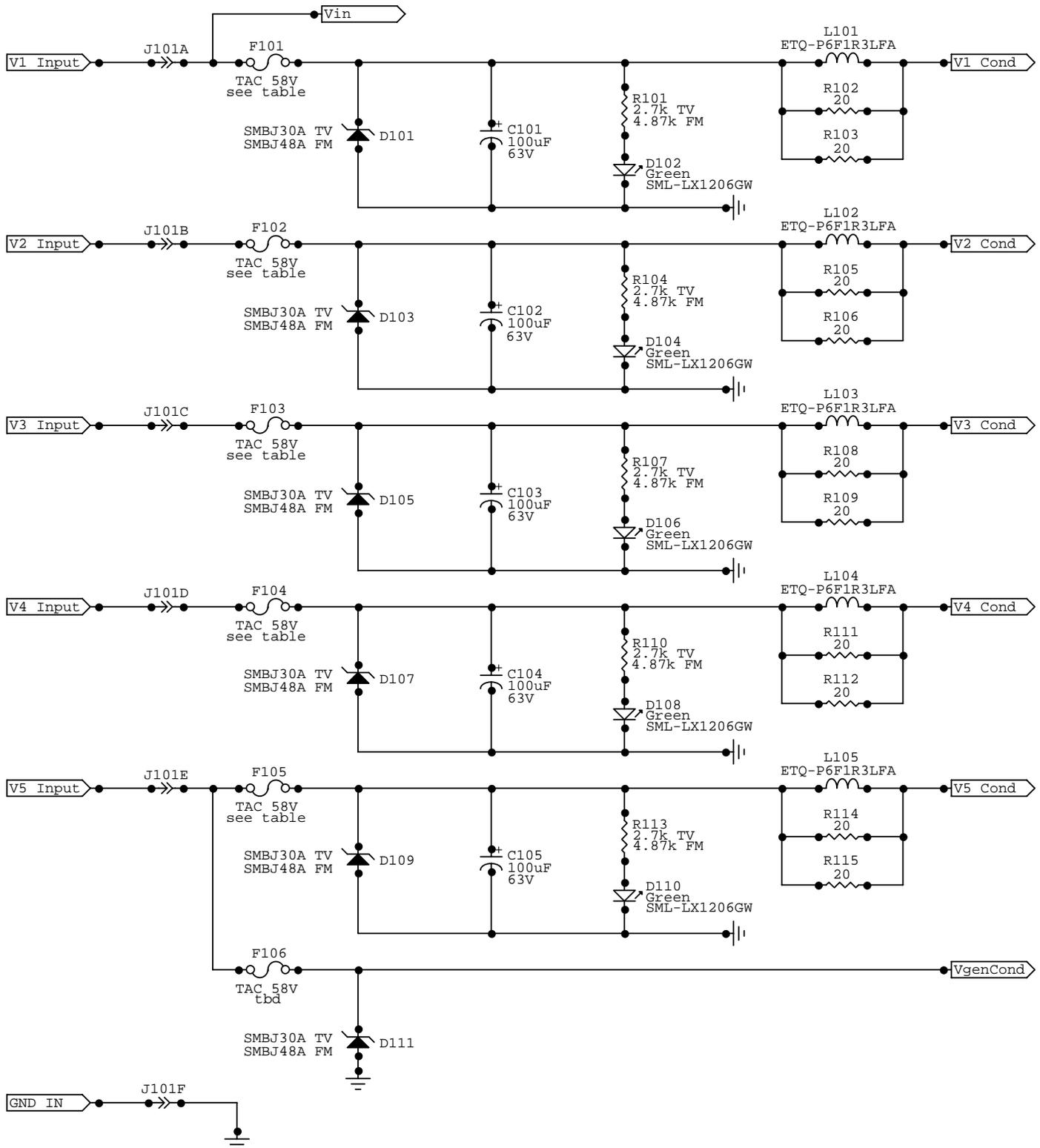

Fuse Table

PA5-UHF	2 A	PA25-VHF-L	4 A
PA10-UHF	3 A	PA25-VHF-H	5 A
P50-UHF	10 A	P200-VHF-L	15 A
P150-UHF	10 A/side	P200-VHF-H	15 A
U60LD UHF	3 A	P400-VHF-L	15 A/side
U200LD UHF	7.5 A/side	P400-VHF-H	10 A/side
P350-FM	15 A		
P750-FM	15 A/side		

A. Sivacoe, N. Hendrickson

User Interface Module

Rev	ID
B	Insight Control System

Date: April 30, 2005 | Page: 1 of 9

User Interface Module

Current Monitoring

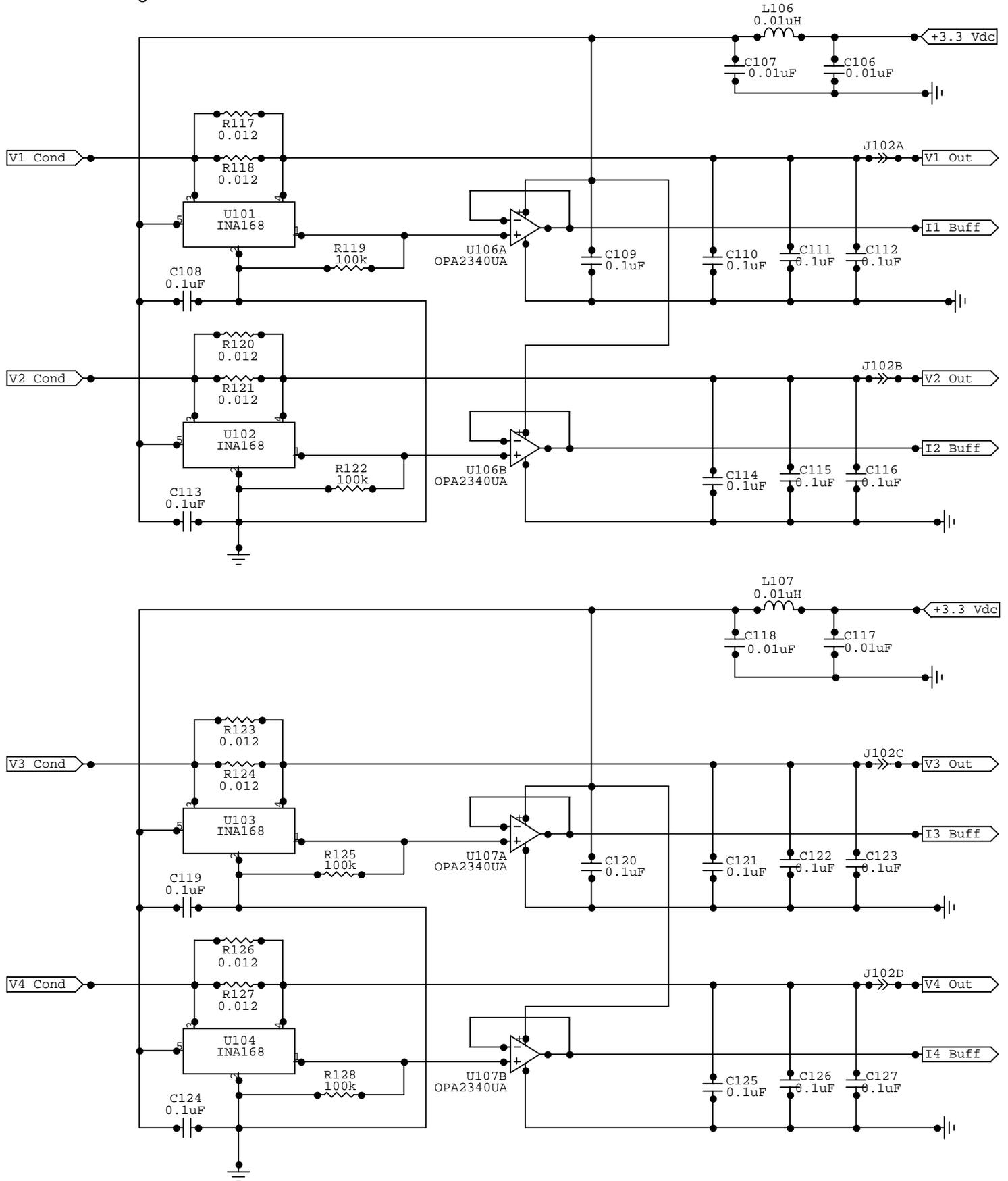

A. Sivacoe, N. Hendrickson	
User Interface Module	
Rev	ID
B	Insight Control System
Date: April 30, 2005	Page: 2 of 9

User Interface Module

Voltage/Current Monitoring

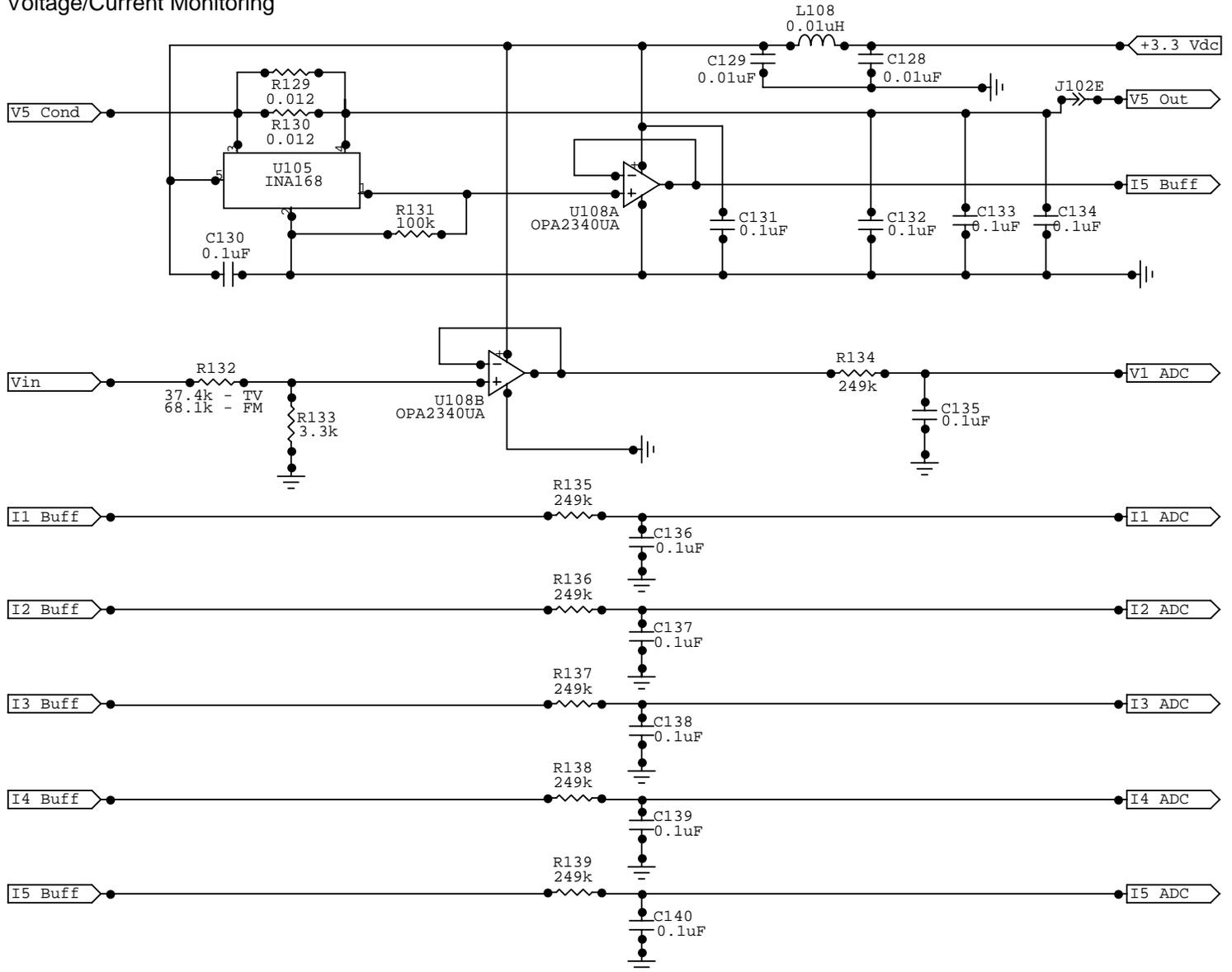

Membrane Switch Inputs

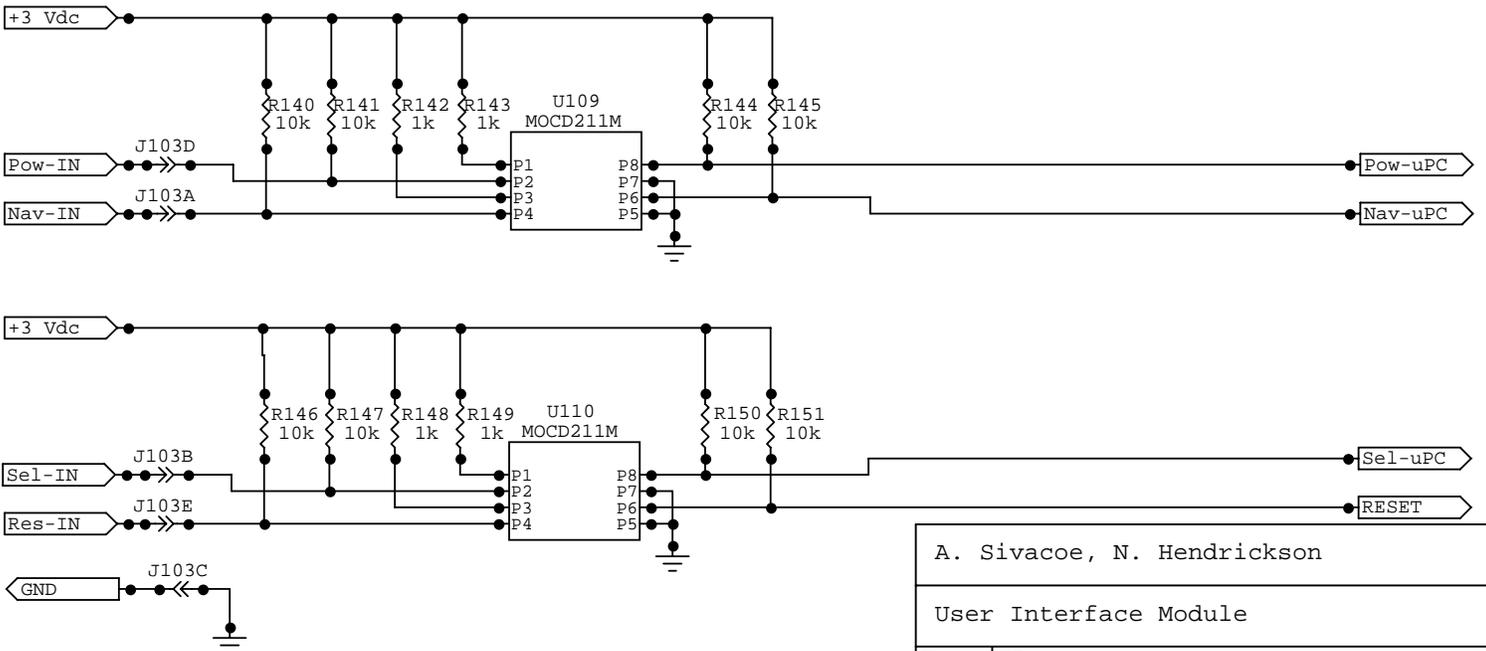

A. Sivacoe, N. Hendrickson

User Interface Module

Rev	ID
B	Insight Control System

User Interface Module

Microcontroller

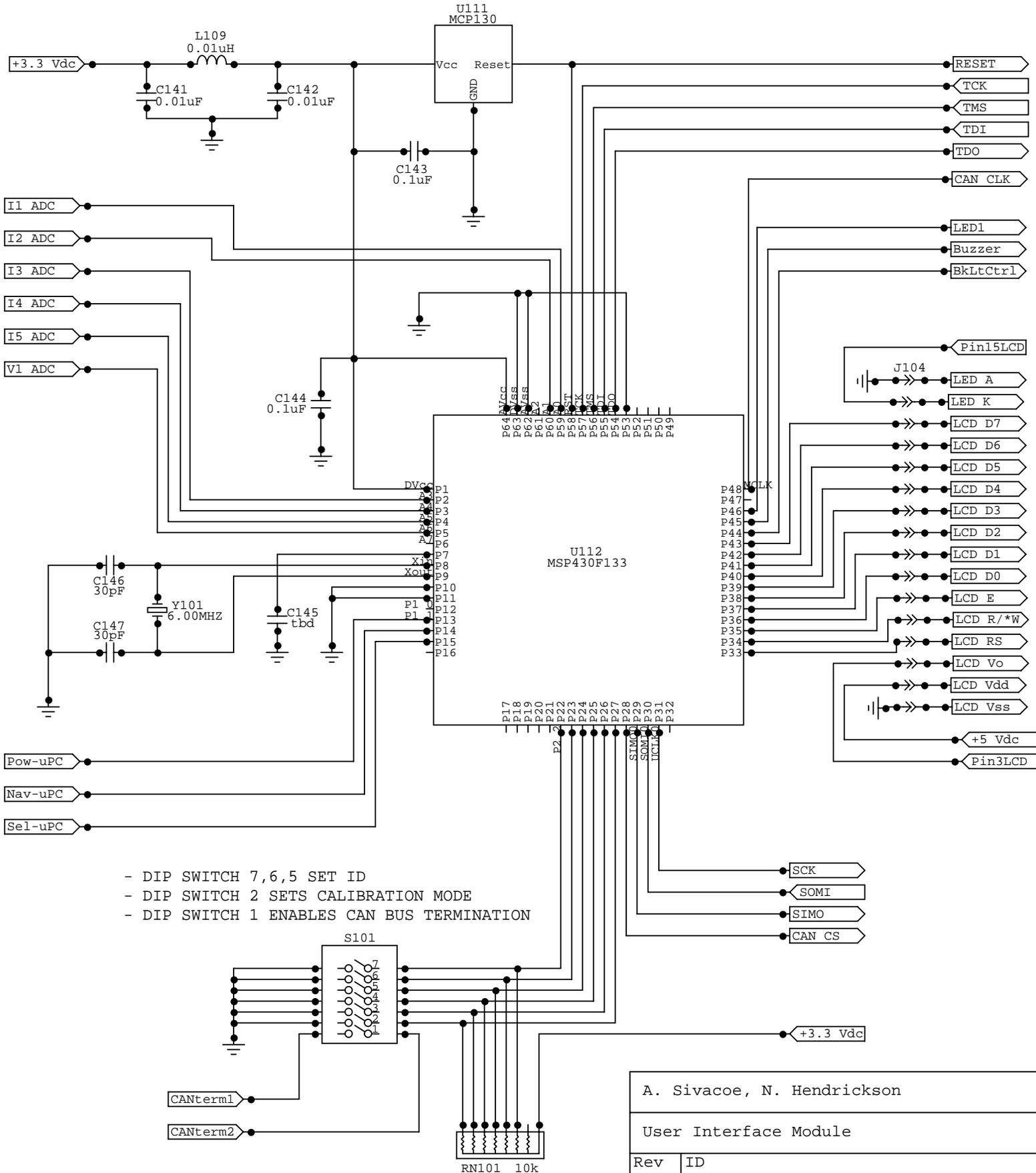

- DIP SWITCH 7,6,5 SET ID
- DIP SWITCH 2 SETS CALIBRATION MODE
- DIP SWITCH 1 ENABLES CAN BUS TERMINATION

A. Sivacoe, N. Hendrickson	
User Interface Module	
Rev	ID
B	Insight Control System
Date: April 30, 2005	Page: 4 of 9

User Interface Module

Power Supplies

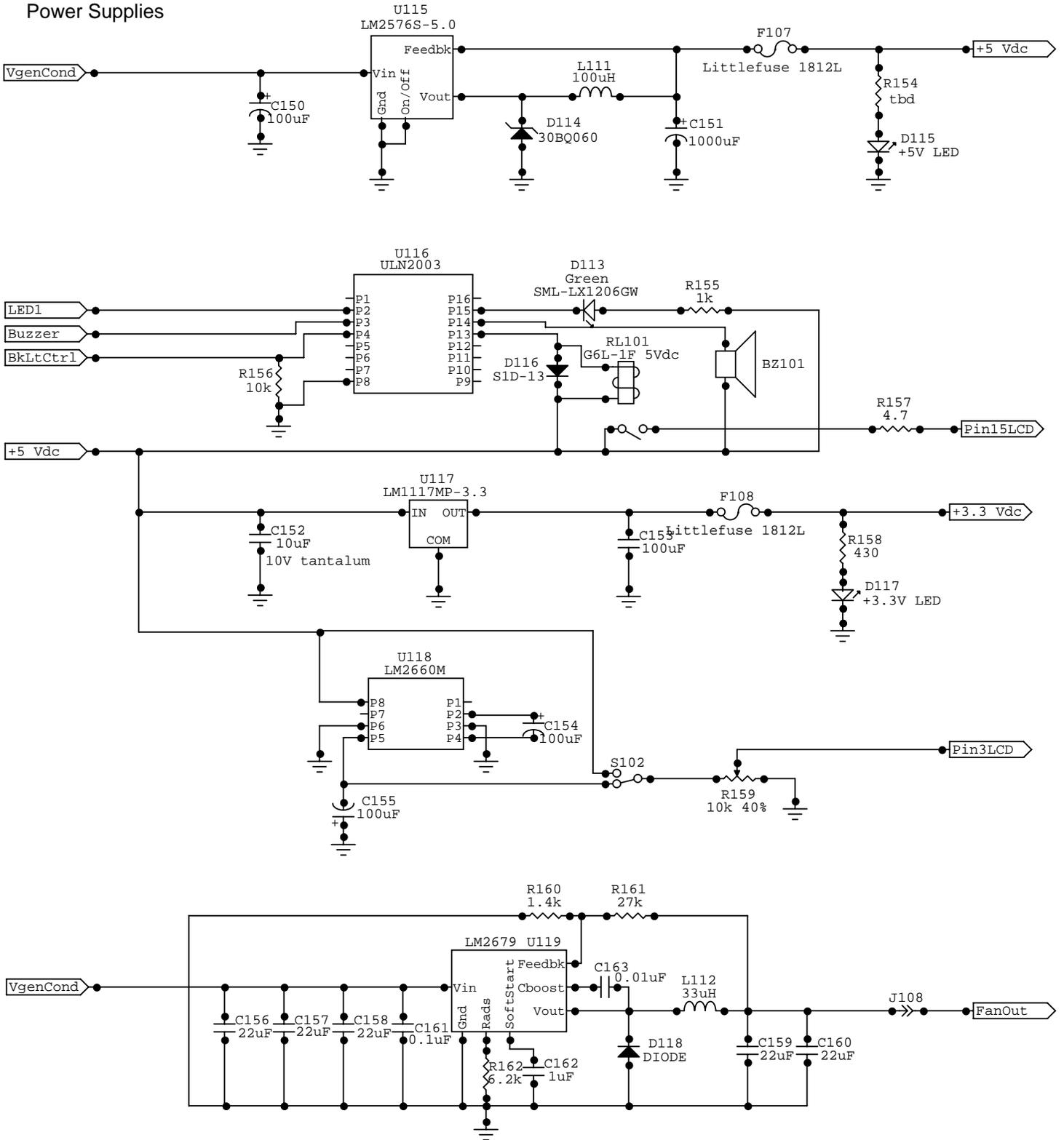

A. Sivacoe, N. Hendrickson

User Interface Module

Rev	ID
B	Insight Control System

Date: April 30, 2005 | Page: 6 of 9

Coupler Conditioning Module

Microcontroller

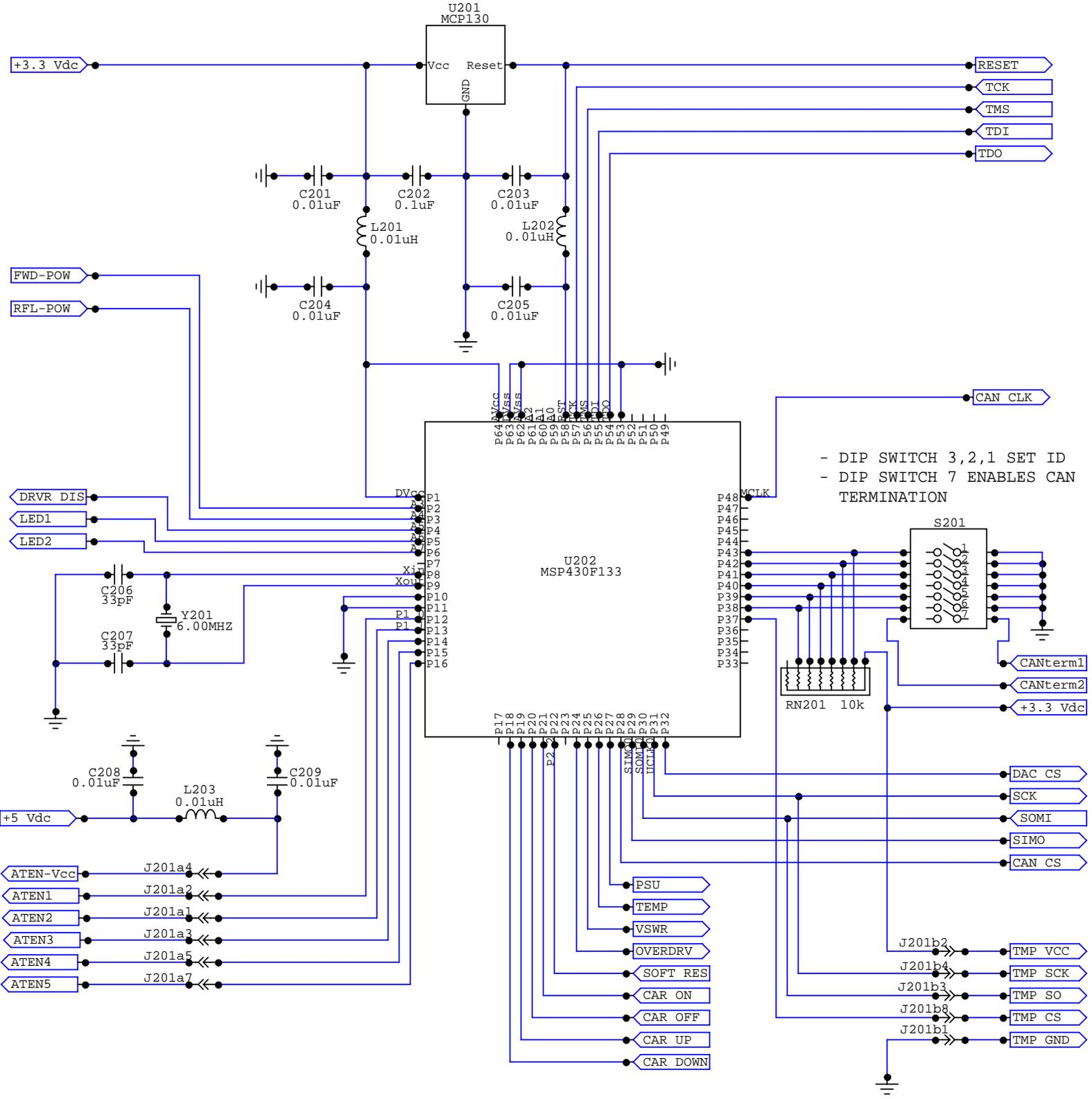

- DIP SWITCH 3,2,1 SET ID
- DIP SWITCH 7 ENABLES CAN TERMINATION

N. Hendrickson, A. Sivacoe	
Coupler Conditioning	
Rev 1.04	ID Insight Control System
Date: June 17, 2005	Page: 1 of 4

Coupler Conditioning Module

CAN and Programmer Interface

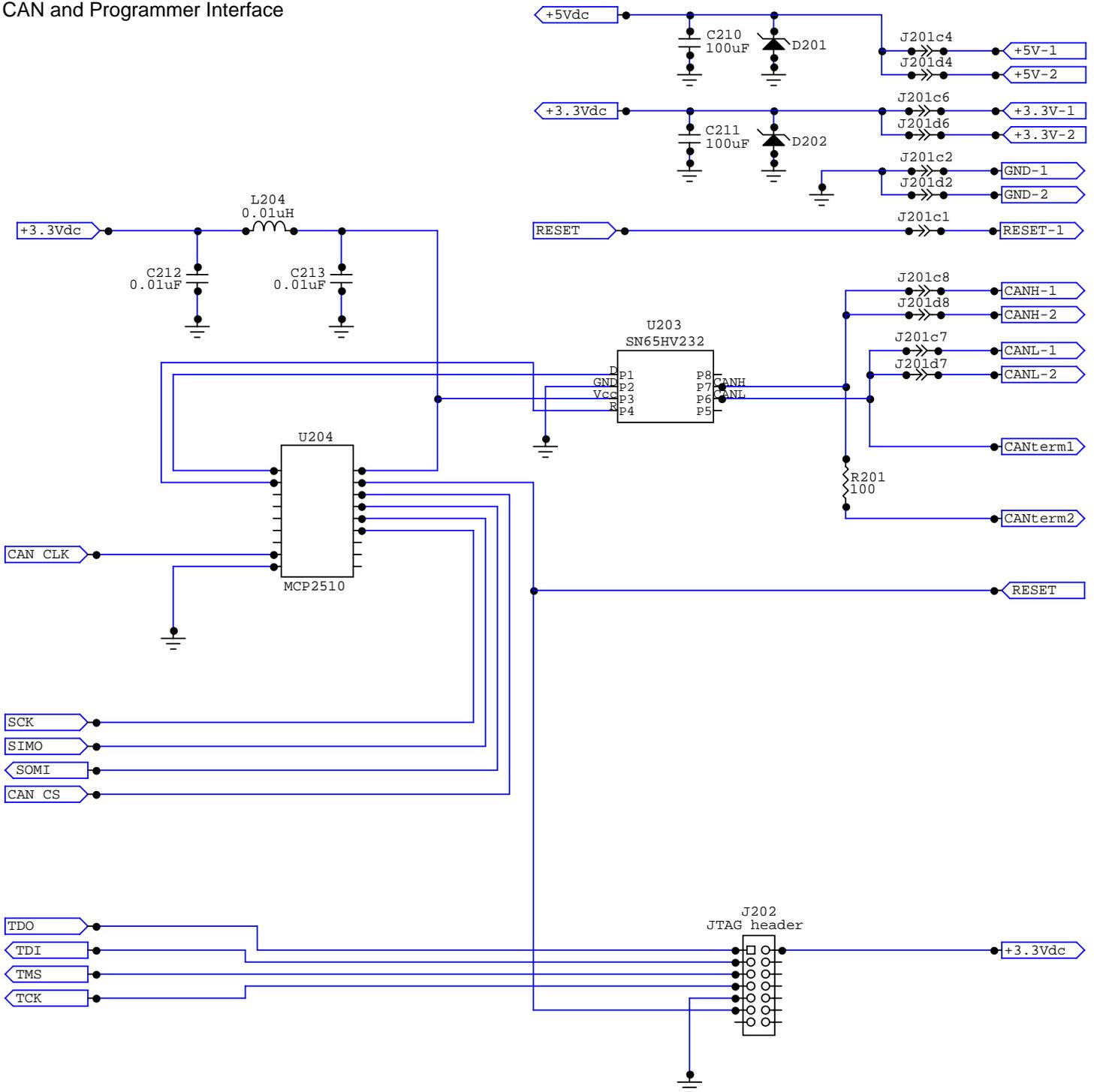

N. Hendrickson, A. Sivacoe	
Coupler Conditioning	
Rev 1.04	ID Insight Control System
Date: June 17, 2005	Page: 2 of 4

Coupler Conditioning Module

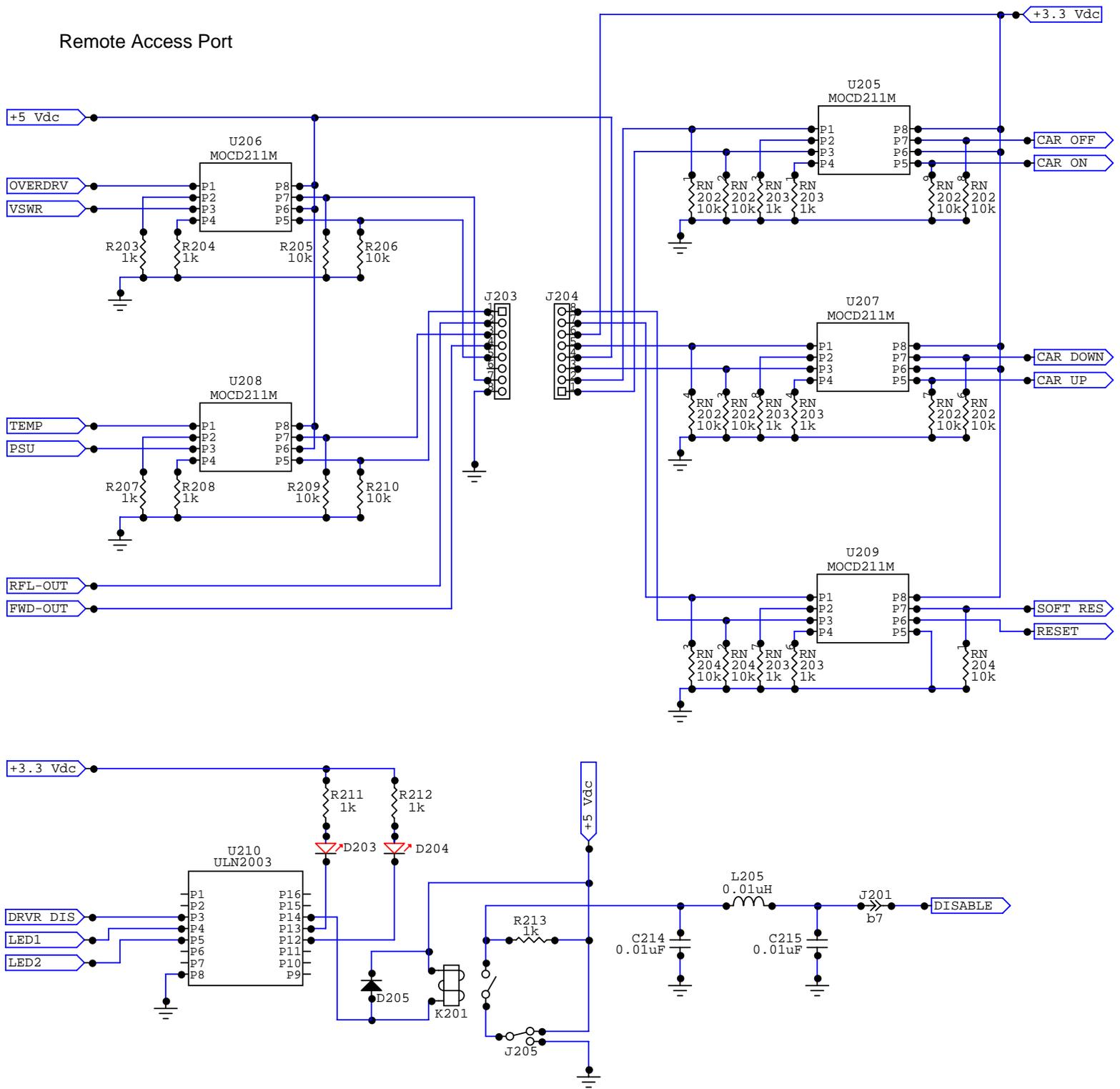

N. Hendrickson, A. Sivacoe	
Coupler Conditioning	
Rev 1.04	ID Insight Control System
Date: June 17, 2005	Page: 3 of 4

Coupler Conditioning Module

RF Power Output

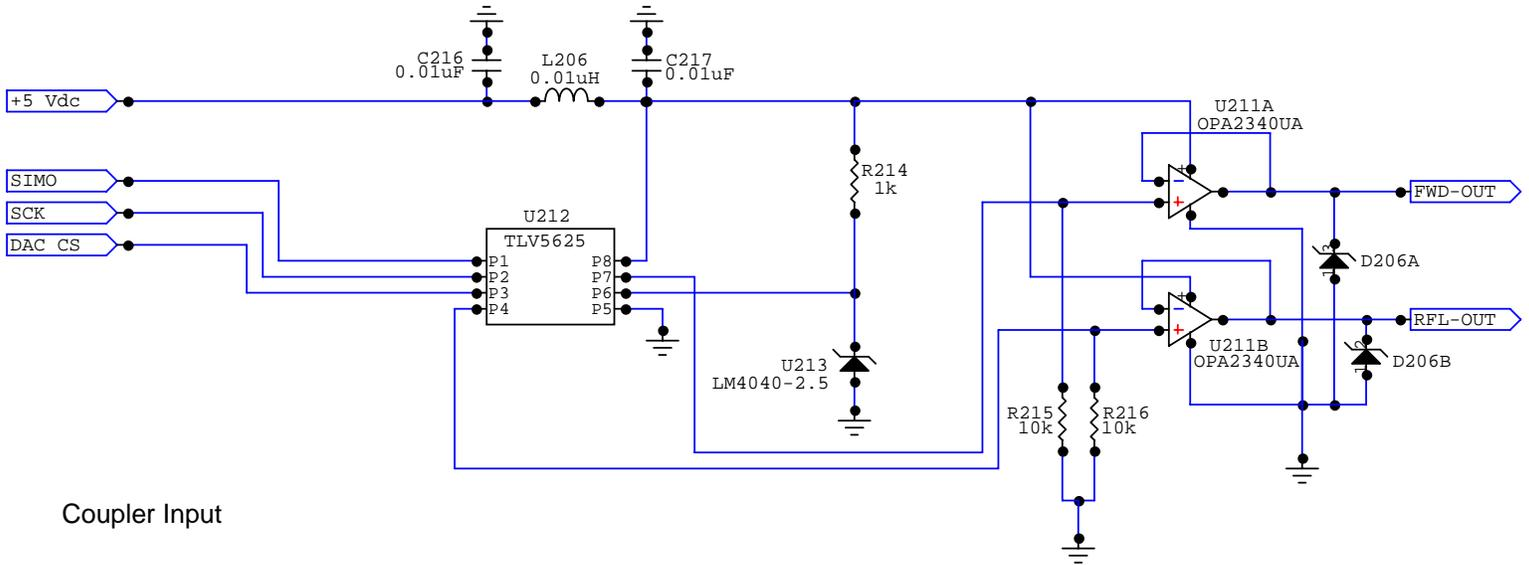

Coupler Input

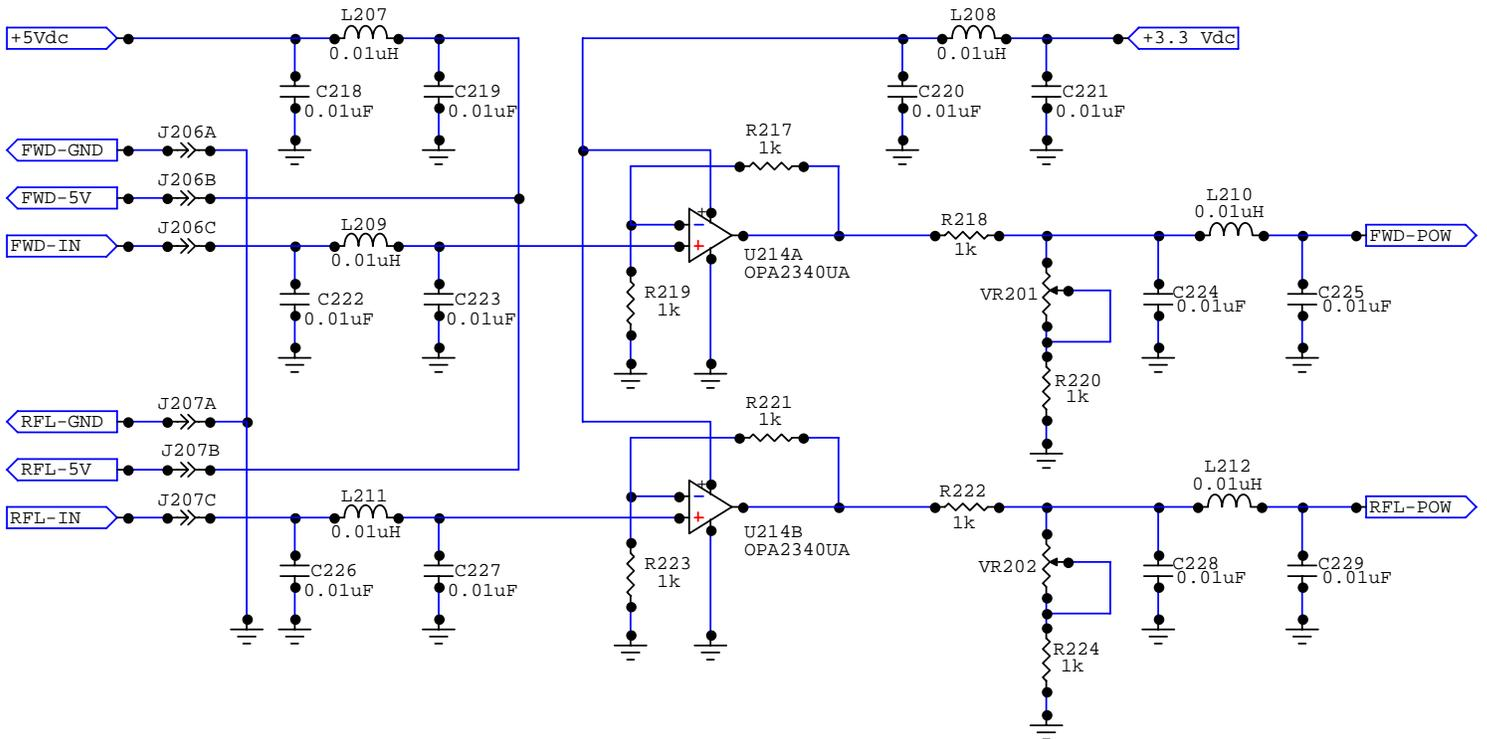

N. Hendrickson, A. Sivacoe

Coupler Conditioning

Rev	ID
1.04	Insight Control System

Date: June 17, 2005 Page: 4 of 4

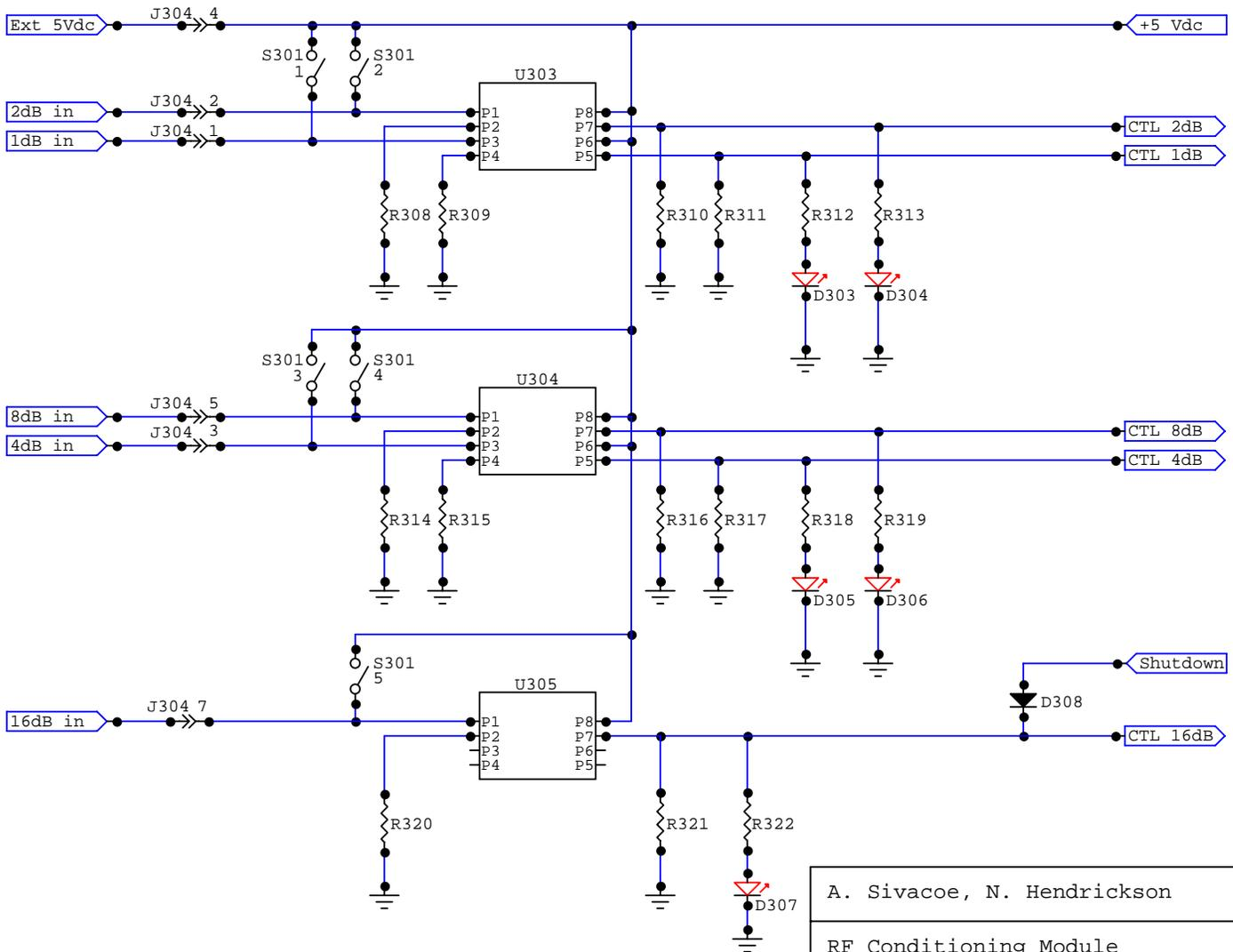
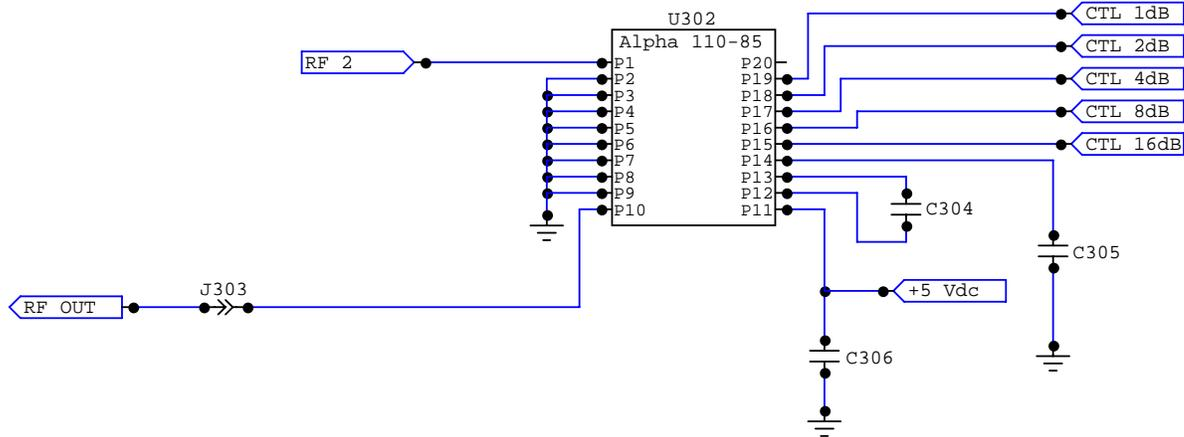
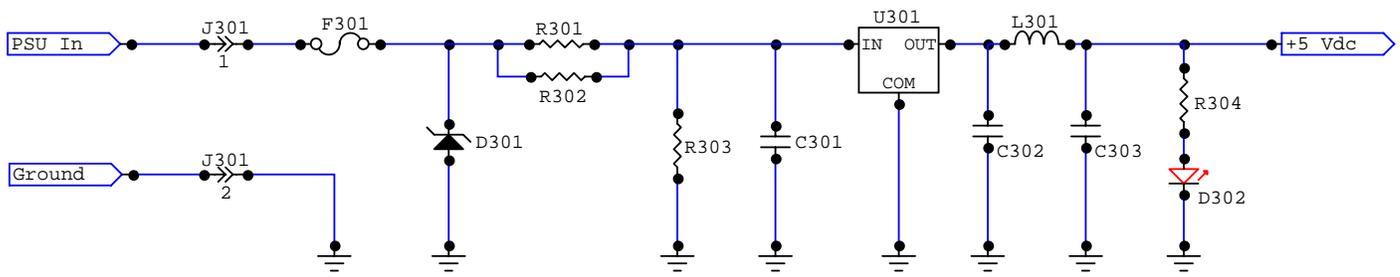

A. Sivacoe, N. Hendrickson	
RF Conditioning Module	
Rev 1.04	ID Insight Control System
Date: Sept. 19, 2005	Page: 1 of 2

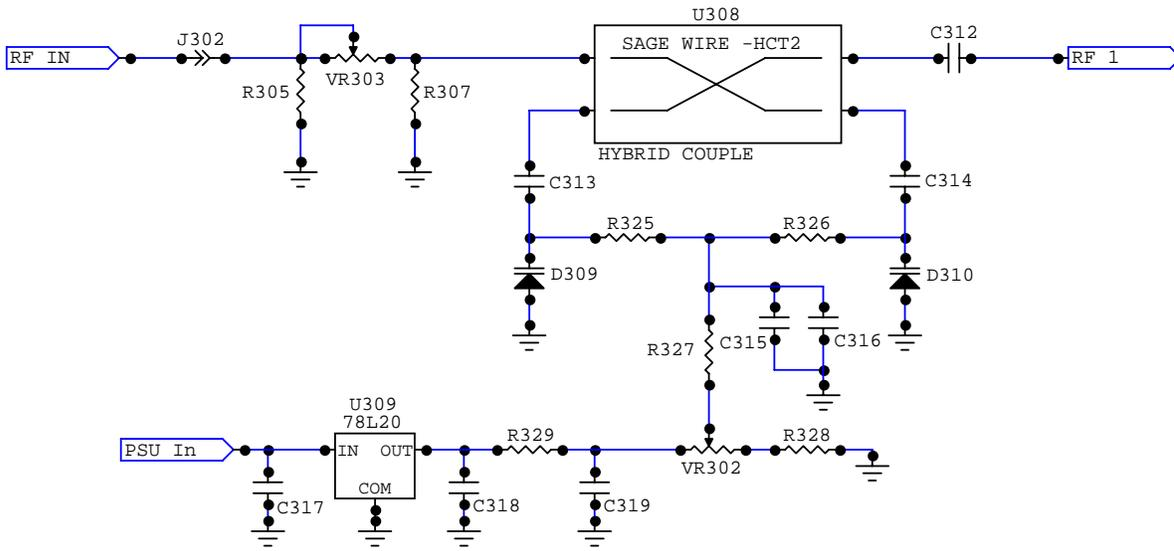
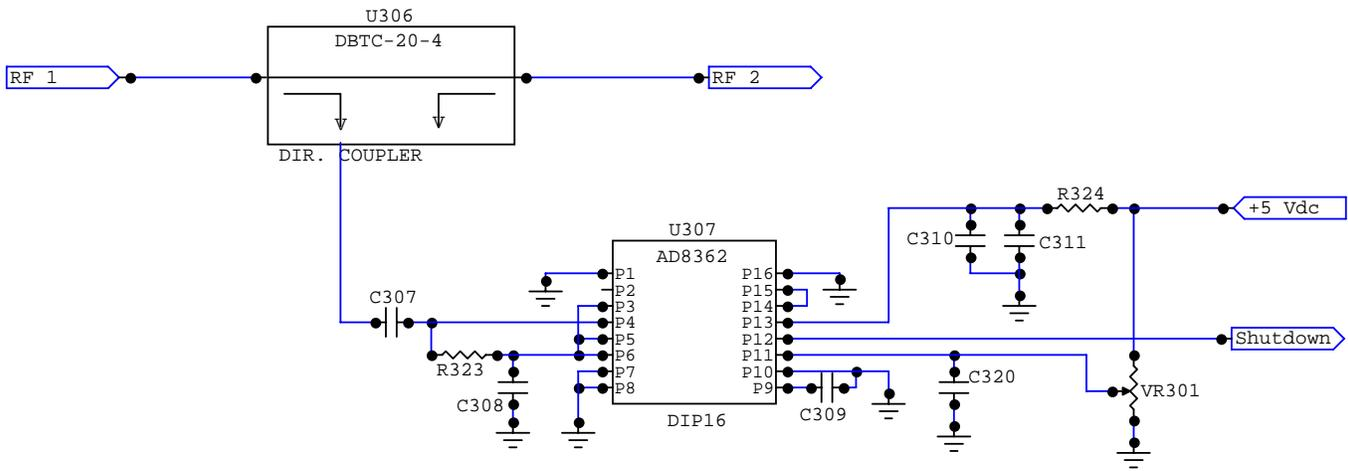

A. Sivacoe, N. Hendrickson	
RF Conditioning Module	
Rev 1.04	ID Insight Control System
Date: Sept. 19, 2005	Page: 2 of 2

Temperature Sensor

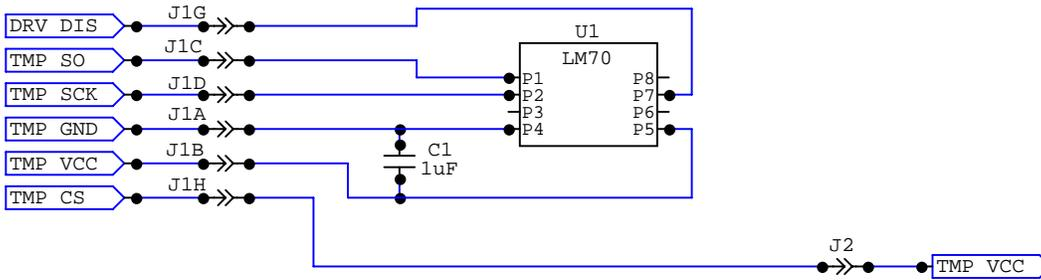

1

N. Hendrickson, A. Sivacoe

Temperature Sensor Board

Rev	ID
1.02	Insight Control System

Date: May 8, 2005	Page: 1 of 1
-------------------	--------------

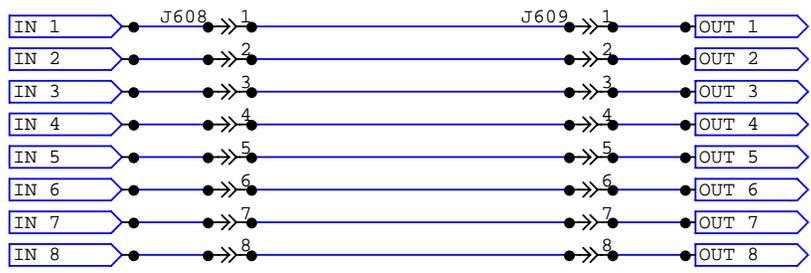
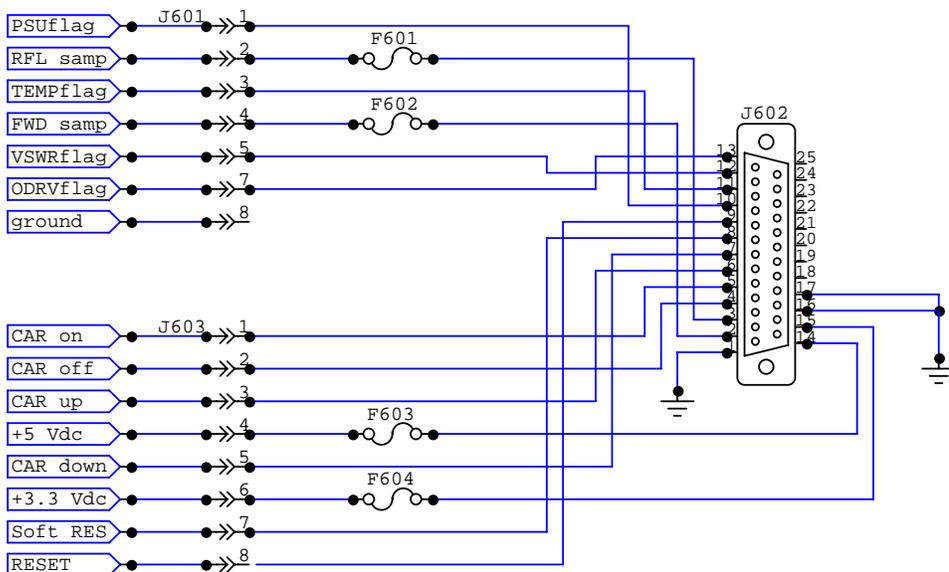

Section VII – Mechanical Section

The heat sink allows the amplifiers to operate at a cooler temperature and prevents overheating, which helps the longevity of the entire system. The heat sink has hollow fins, which help dissipate the heat from the amplifiers faster than a conventional serrated or corrugated fin.

In addition to the cooling effects of the heat sink, there is a fan that provides 110 cubic feet per minute (CFM) of air flow (into zero static pressure).

Section VIII - Installation

This section contains installation recommendations, unpacking, inspection, and installation instructions for the power amplifier. We are sure that you are chomping at the bit to install your new system, so we recommend that you read the following sections very carefully.

Building Recommendations

The quality of the building is of great importance if you are to expect long life and continued performance from the power amplifier. The building must be clean, dry, temperature controlled and secure. Don't forget to allow space in the building for any additional racks to house test equipment, a workbench area, line regulating transformers, ladders, equipment and parts storage, first aid kit, emergency generator if used, as well as heating and cooling devices that may be unique to your installation. A sloping roof will tend to develop leaks less rapidly. The building should be well roofed with good material. The cooling load will be lowered with reflective or light colored roofing material.

Heating and Cooling Requirements

The environment's temperature will contribute greatly to the length of the power amplifier's life. Technalogix recommends that the building's filtered air intake must have capacity for all air-flow in the building plus an additional 20%. Keep the intake below the roofline to avoid intake of solar heated air. Please ensure that the intake and exhaust areas are on the same side of the building to avoid pressure differentials during windy conditions. Also, do not position intake near exhaust's preheated air. If air conditioning is required to cool the shelter, discuss the situation with a qualified HVAC technician. Under average conditions, 12,000 BTUs will cool approximately 500 square feet to a comfortable level.

Electrical Service Recommendations

Technalogix recommends that a qualified, licensed local electrician be consulted for the required electrical service. We suggest local electricians because:

- The personnel knows the local codes
- The personnel can be on site readily
- You are apt to get better overall support if you give what business you can to local suppliers

Technalogix recommends that proper AC line conditioning and surge suppression be provided on the primary AC input to the power amplifier. All electrical service should be installed with your national electrical code in your area, any applicable provincial or state codes, and good engineering practice. Special consideration should be given to lightning protection of all systems in view of the vulnerability of most transmitter or translator sites to lightning. Lightning arrestors are recommended in the service entrance. Straight and short grounds are recommended. The electrical serviced must be well grounded. Do not connect the unit to an open delta primary power supply, as voltage fluctuations could harm the unit. Branch your circuits. Do not allow your lights, your workbench plugs, and your transmitting or translating equipment to operate on one circuit breaker. Each transmitter or translator should have its own circuit breaker, so a failure in one does not shut off the whole installation.

Antenna and Tower Recommendations

Your preliminary engineering workgroup should establish your antenna and tower requirements, both for receiving and transmitting antennas. Construction of sturdy, high quality antenna/tower systems will pay off in terms of coverage of your service area, the overall quality and saleability of your radiated signal, and reduced maintenance expenses. Technalogix provides complete turnkey antenna systems if needed. If your site is serving as a translator, your receiving antenna should be in line of sight to the originating station all year round. The foliage will change with season. Transmitting antennas can enhance or seriously impair the transmitter/translator output.

The selection, routing, and length of coaxial cable are extremely important in the installation. If there is a 3 dB line loss in the cable between your unit's output and the transmitting antenna, a 100-watt unit will only deliver 12.5 watts to the antenna. Buy the best cable you can obtain, route it via the shortest way to the antenna, and keep it straight. Do not form it into sharp bends on its way. Do not use any more cable fittings for the installation than absolutely necessary. All cautions here apply equally to all coaxial cables in the system - input and output.

Pay attention to radial ice accumulation when designing the transmission system. It is not uncommon for at least an inch of ice to build up on the tower and antenna. This in turn significantly increases the weight, cross section, and wind loading of the system.

Attaching the transmission line to the tower is crucial to maintain a safe and reliable operation. Nylon wire ties and electrical tape will breakdown in the sunlight and ultimately fail, creating a potentially dangerous situation. It is important to use proper clamps and hoisting grips and also ensure that the transmission line is grounded to the tower in several locations. When high currents flow through the tower in the event of lightning strikes, some of that current will through the outer conductors of the transmission lines. Due to the resistance difference between the steel tower and copper transmission line, a significant voltage can be developed, often resulting in arcing between the outer jacket and outer conductor, thus pitting the conductor.

Preventative maintenance is crucial in ensuring that safety is maintained. Specifically, check that transmission line grounds are tight and are not missing any hardware. Frequently inspect support clamps or spring hangers. Consider investing in an ice break, if you haven't already done so, as shards of falling ice can damage the transmission line – and if it is going to happen, it will happen at an important time. Check the tower light photocells and conduit.

The better-known tower manufacturers offer complete technical and safety documentation with their towers. Be sure that you have this information as it regards wind loading, guying, etc. The best-designed antenna system will function poorly if shortcuts and compromises are used during installation. Follow the manufacturer's instructions exactly, along with any engineering data prepared for the site. Be absolutely safe and certain about this aspect as human lives may be at stake.

Shelter Security

The FCC requires that the transmitter or translator be secure from entry or control by unauthorized persons, and that any hazardous voltages or other dangers (including most tower bases) be protected by locks or fences as necessary to protect personnel and prevent unauthorized tampering or operation. Security of the building further implies that it be secure from wildlife. Use sturdy construction materials, including sheet metal if necessary. Holes around conduit, cable, and other similar entry points should be stuffed with steel wool and caulked to prevent entry of wildlife. Other features of security for your shelter may include its location with respect to the prevailing wind conditions. A location leeward of some natural topographical feature will prevent wind damage and snowdrifts. Check the soil runoff conditions that may slow or hasten wind or water erosion and other concerns that may be unique to your location.

Unpacking and Inspection

Check the outside of the container. Carefully open the container and remove the power amplifier. Retain all packing material that can be reassembled in the event that the equipment must be returned to the factory.

Exercise care in handling equipment during inspection to prevent damage due to rough or careless handling.

Visually inspect the enclosure of the power amplifier for damage that may have occurred during shipment. Check for evidence of water damage, bent or warped chassis, loose screws or nuts, or extraneous packing material in connectors or fan failures. Inspect all connectors for bent connector pins. If the equipment is damaged, a claim should be filed with the carrier once the extent of the damage is assessed. Technalogix cannot stress too strongly the importance of immediate careful inspection of the equipment and subsequent immediate filing of the necessary claims against the carrier if necessary. If possible, inspect the equipment in the presence of the delivery person. If the equipment is damaged, the carrier is your first area of recourse. If the equipment is damaged and must be returned to the factory, phone for a return authorization. Claims for loss or damage may not be withheld from any payment to Technalogix, nor may any payment due be withheld pending the outcome thereof. Technalogix cannot guarantee the carrier's performance.

Location and Function of Controls and Connectors (TAV-25 Power Amplifier)

The following illustration depicts the location of the connectors when installing the 25-watt power amplifier (TAV-25).



<i>POWER -</i>	Tactile button to turn carriers on and off.
<i>NAVIGATE -</i>	Tactile button to move between menu items, or to refresh the screen after it has timed out.
<i>SELECT-</i>	Tactile button to select menu item, or to refresh the screen after it has timed out.
<i>RESET -</i>	Tactile button to reset microcontroller in control board. Also clears existing faults. The amplifier will come back on with the soft start feature.
<i>RF IN –</i>	RF input from modulator or processor. BNC connector, 50 ohm.
<i>RF OUT –</i>	100-watt RF output. Connects to inline wattmeter (not supplied) and antenna. N connector, 50 ohm.
<i>REMOTE PORT -</i>	Port to monitor and control the amplifier externally. See “ Monitor and Control” section for pin-out.
<i>AC IN –</i>	AC input to switching power supply.
<i>AC BREAKER –</i>	Resettable circuit breaker is used to protect against inrush currents and high current draw from switching power supply. The thermal circuit breaker is a single pole configuration.
<i>AC ON/OFF -</i>	AC rocker switch (SPST) to supply AC to the AC-DC switching power supply

Initial Hook Up

1. Ensure that the antenna has been swept and has a return loss of greater than 20dB (VSWR = 1.2:1). This should be done before connecting the antenna cable to the transmitter output.
2. Check that your video source is present.
3. Place the transmitter/translator in its permanent location near a receptacle supplying required AC voltage.

DO NOT APPLY AC POWER AND TURN ON POWER TO THE TRANSMITTER /
TRANSLATOR AT THIS TIME SINCE THE RF OUTPUT MUST BE PROPERLY
LOADED BEFORE OPERATION.

4. Place an appropriate AC power line protector, conditioner, and/or surge suppressor across the AC supply line.
5. Hook up the modulator or processor as shown in their respective manuals for a transmitter or translator. **Do not** connect the modulated signal from the RF OUT on the modulator or processor to RF IN on the power amplifier at this time. Because of the characteristics of LDMOS devices, the RF drive should not be connected to the power amplifier until after the power supply and bias voltages are present and stable.
6. Plug power amplifier into AC mains.
7. Switch AC rocker switch to “on” position.
8. Ensure that the audio modulation is set to 100% with the audio signal supplied, as described in the appropriate modulator/processor manual (will be factory set).
9. Ensure that the video modulation level is set to 87.5% with the video signal supplied, as described in the appropriate modulator/processor manual (will be factory set).
10. Connect the transmitting antenna cable to the RF OUT N-type connector on the power amplifier enclosure RF output.

Section IX - Operating Procedure

Assuming the previous installation instructions have been completed and cautions noted, and the TAV-25 power amplifier is ready to receive a properly modulated video and audio signal, proceed with the following steps to place the system in operation. The TAV-25 power amplifier has been factory aligned for channel frequency (per system specification), signal levels and optimum performance.

IT IS HIGHLY RECOMMENDED THAT YOU RUN YOUR SYSTEM INTO A DUMMY LOAD BEFORE INSTALLING TO MAKE SURE THERE ARE NO DAMAGES CAUSED IN SHIPPING AND THE UNIT IS RUNNING PROPERLY

1. Do not apply RF drive signal to the power amplifier at this time.
2. Verify that all control and RF cables are tight and properly seated in or on the mating connector.
3. Plug the modulator or processor into AC mains.
4. Plug the 3U power amplifier enclosure into AC mains.
5. Switch AC rocker switch to "ON" position.
6. Verify that the power amplifier enclosure's fan is on.
7. Ensure that the modulator/processor is turned on and set up according to its instructions. Depress the POWER tactile button to turn the unit on.
8. The internal soft start circuitry will turn the bias voltages off until the power supply to the amplifier pallets is fully stable. The message on the LCD indicates when the soft start is running. Once complete, the Forward and Reflected Power and Power Supply readings will appear on the LCD.
9. After the soft start is complete, apply the RF drive signal (which still should be turned down) between the modulator or processor and the power amplifier RF In. This ensures that the RF drive signal is applied only after the power supply is stable and the bias voltages are applied to the amplifier.

10. The TAV-25 LCD shows the user the present status of the amplifiers. Adjust RF output power to desired level (see Important RF Power Notice in previous section). Verify that the FWD Power reads 80% to 100% on the filter enclosure - depending on signal content. The system is set up for 25 watts peak visual power using the sync and blanking signal and should read 100 % FWD Power on the LCD **under this condition only**. The output power level can be adjusted using the modulator or processor's RF output level adjust. Keep in mind that the system will attenuate should the forward RF output power level be exceeded.
11. Ideally, the RFL Power should read zero. However, should a high VSWR be detected, the system will automatically shut down and cycle as previously described. This reading is also displayed as a percentage of rated forward power.
12. Verify that the power supply reads approximately 28 Volts DC (see supplied final inspection sheet for factory settings of power supply levels) on the LCD of the power amplifier.
13. Look at the transmitted output using a suitable monitor. The picture and sound quality should be clean and sharp. If the output picture and sound quality is unsatisfactory, check the input signals, connections to the antenna system, antenna and transmission line VSWR, and the physical condition of the antenna.

If reception problems are encountered, and the quality of transmission is satisfactory, the difficulty is often with the receiving antenna or with obstructions in the path between the transmitter/translator and receiver.

Section X – Maintenance and Troubleshooting

Periodic Maintenance

If your unit employs a filter on the air inlet for the fans, the filter should be cleaned every 30 days. If the equipment is operated in a severe dust environment, the filters on the inlet fan may need to be cleaned more regularly. *Turn the system off and unplug all of the AC inlet cords.* The filter can be lifted off the fan and cleaned using an air compressor at low pressure. While the filter is out, clean the fan blades themselves with a small brush. The fans themselves do not need lubrication.

The interior of the cabinets should be cleaned and inspected annually. *Turn the system off and unplug all of the AC inlet cords.* Remove the top lid by unscrewing the 6-32 machine screws.

Use extreme caution when working near the AC input terminal. The power amplifier and power supply store hazardous capacitances and voltages.

Using either compressed air or a brush with soft bristles, loosen accumulated dust and dirt and then vacuum the interior of the cabinet. Complete a visual inspection of the interior, making sure there are no loose connections or discolorations on any components from heat. Nothing inside the power amplifier enclosure exceeds a temperature that is not comfortable to the touch under normal operating conditions, so any signs of discoloration indicate potential damage.

All modular components inside the enclosure are attached to aluminium mounting plates for easy removal and replacement. Ensure that plates are secured and the mounting hardware is tight.

Troubleshooting

The first and most important aspect of troubleshooting anything is to be systematic. Note where you have looked and what you found.

Look first for the obvious.

- Make a physical inspection of the entire facility. Are all necessary connections properly made? Do you see any signs of obvious damage within the equipment?
- Is there DC power to the site and the equipment?
- Are all the switches in the correct operating position?
- Is the input signal present?
- Check LCD readings for presence of forward and reflected power and 30 V DC supply levels.

The above is an aid in determining the fault if some aspect of the system is not operating. The following table deals with quality of operation:

Symptom	Possible Fault	Correction
Weak output or picture	Low level input signal	Verify presence and level of input signal
	Low output power	Verify power amplifier output with wattmeter and dummy load
	Incorrect modulation depth	Adjust to meet specification
High reflected power	Incorrect load	Ensure amplifier connected to transmission line
		Ensure correct antenna impedance (50 ohms)
		Check antenna tuning and VSWR. Verify correct cable for transmission line length
		Check all cables for visible damage (kinks, nicks or cuts)
		Check all connectors for poor connections, water or corrosion
		Check alignment of antenna
		Check for physical damage of antenna, including ice build-up

**Thank you
for choosing
Technalogix Ltd.**