



WIRELESS ADSL2+GATEWAY TD5136



User's Manual

Table of Contents

Chapter 1: Product Overview	5
1.1 Features	5
1.2 Package Contents.....	6
1.3 Hardware Overview	7
1.3.1 Front Panel	7
1.3.2 Rear Panel.....	9
Chapter 2: Installation	10
2.1 Connect the Power.....	10
2.2 Connect Wired Devices	11
2.3 Connect Wireless Devices.....	11
2.3.1 WLAN.....	11
2.3.2 Wi-Fi Protected Setup (WPS).....	11
2.4 Connect the Broadband (DSL)	12
2.4.1 Use a Splitter	12
2.5 Check the Installation	12
Chapter 3: Configure the Computer	13
3.1 Windows XP	13
3.2 Windows Vista.....	14
3.3 Windows 7.....	14
Chapter 4: Access the Wireless Gateway.....	15
4.1 Initial Setup	15
4.2 Login.....	21
4.3 The Interface	21
4.4 Using the Menu.....	22
Chapter 5: Technicolor Gateway	23
5.1 System Information.....	23
5.2 System Configuration	24
5.2.1 DSL Service Configuration	24
5.2.2 Date and Time Configuration.....	24
5.2.3 Web Browsing Interception.....	25
5.3 Event Logs	25
Chapter 6: Broadband Connection	26

6.1.1	DSL Connection	26
6.1.2	Internet Services	27
Chapter 7:	Toolbox	28
7.1	Remote Assistance.....	28
7.1.1	Enable Remote Assistance	29
7.1.2	Disable Remote Assistance.....	29
7.2	Game & Application Sharing	29
7.2.1	Assign a Game or Application	30
7.2.2	Modify Assigned Game or Application	31
7.2.3	Create a New Game or Application	32
7.2.4	Modify a Game or Application	33
7.3	Parental Control.....	34
7.4	Firewall	35
7.4.1	Change Firewall Security Level	35
7.4.2	Create a New Security Level	36
7.4.3	Set Filter Rules.....	36
7.5	Intrusion Detection	37
7.6	Dynamic DNS	38
7.7	User Management.....	39
7.7.1	Add New User.....	39
7.7.2	Reset Password.....	40
7.7.3	Manage Users	40
7.8	Content Sharing	40
7.8.1	Share Content Using Network File Server.....	41
7.8.2	Share Media Files Using Media Servers.....	42
7.8.3	Share Files Using FTP Server.....	42
7.8.4	Unmount USB Storage Device	42
7.8.5	USB Printer Sharing	43
7.8.6	3G Dongle Sharing	46

Chapter 8: Home Network.....	46
8.1 Devices.....	47
8.1.1 View or Modify Device Information.....	48
8.1.2 Assign Game or Application to Device.....	48
8.1.3 Remove a Shared Game or Application	48
8.1.4 Assign a Public IP Address to Device	49
8.2 Interfaces.....	49
8.2.1 Local Network Interface.....	50
8.2.2 Wireless Access Point.....	52
Appendix	54
A. Wireless Considerations	54
B. Regulatory & Safety Information	55
C. Specifications.....	58

Chapter 1: Product Overview

Thank you for choosing Technicolor® Wireless n ADSL2+ Gateway. This Wireless Gateway combines the functionality of an ADSL / ADSL2 / ADSL2+ modem and Internet gateway in one. You can access the Internet and share resources such as printers, scanners, and files, via a wireless connection or through one of the Ethernet ports. The various security features, such as WPS, WPA2, SPI, and NAT, protect your data and privacy online. The web-based utility allows you to configure your Wireless Gateway easily.

1.1 Features

- Compliant with ADSL G.dmt (G.992.1), G.lite (G.992.2) standards
- Compliant with ADSL2 G.dmt.bis (G.992.3) and ADSL2 + G.992.4 standards
- Up to Up to 24Mbps downstream, 1.2Mbps upstream with ADSL2+ service
- IEEE 802.11b/g/n infrastructure operating modes
- Supports IPv4 and IPv6 protocols
- Supports web-based configuration
- Supports Command Line Interface (CLI) via Telnet
- Supports NAT, SPIF
- Supports VLAN and QoS
- Supports firewall protection
- Supports up to 8 permanent virtual circuits (PVC)
- Supports Wi-Fi Multimedia (WMM)
- Supports Wi-Fi Protected Setup (WPS) for easy connection
- Supports wireless data encryption with 64/128-bit WEP standard
- Supports enhance security for WPA-TKIP, WPA2-AES, WPA, and WPA2
- USB 2.0 for 3G backup

1.2 Package Contents

Check if the package contains the following items. If any item is missing or appears damaged, contact your dealer.

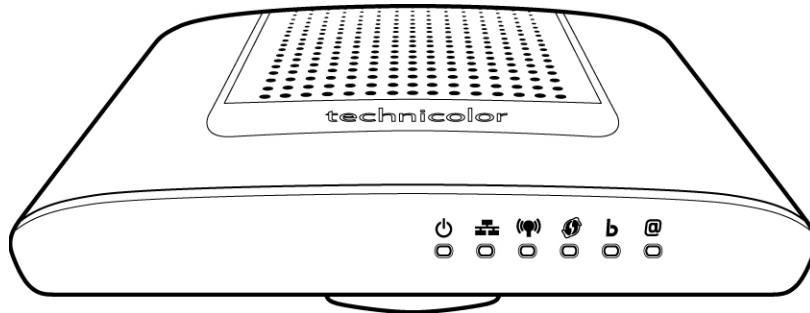

Wireless n ADSL2+ Gateway

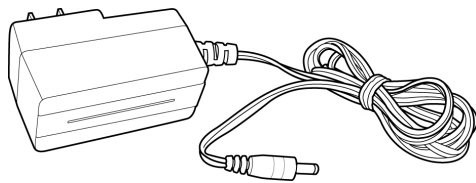

Power adapter

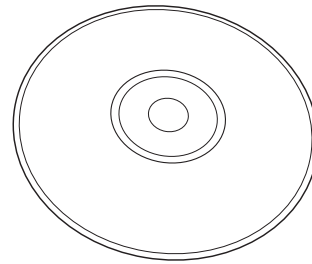

CD-ROM with User's Guide

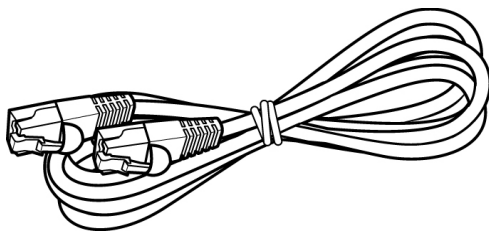

RJ-45 Ethernet cable

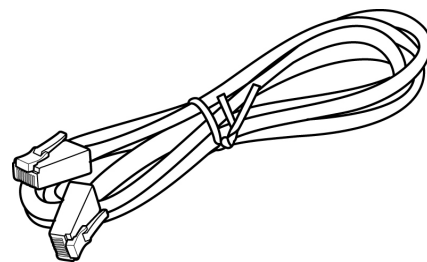

RJ-11 telephone cable

1.3 Hardware Overview

1.3.1 Front Panel

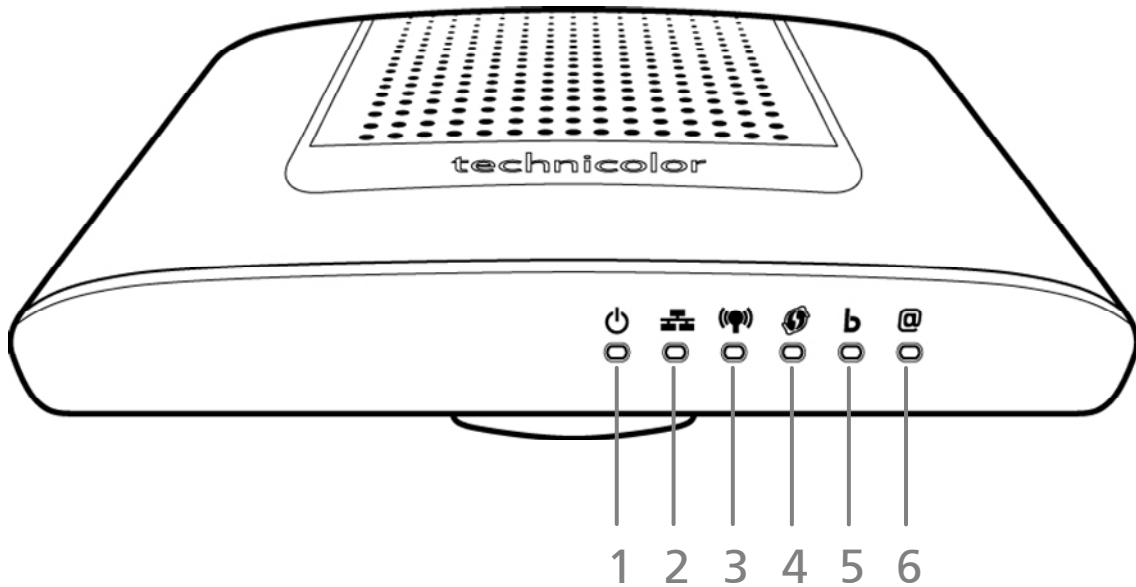

No.	LED	Description
1	Power LED	<p>Lights up when the device is powered on.</p> <ul style="list-style-type: none"> • Solid GREEN – Indicates normal operation. • Flashing GREEN – Firmware upgrade in progress. • Solid RED – Indicates malfunction. • Off – The device is powered off.
2	Ethernet LED	<ul style="list-style-type: none"> • Solid GREEN – A wired connection is established. • Flashing GREEN – Data transmission is in progress. • Off – No wired connection detected.
3	WLAN LED	<p>Lights up to indicate wireless connection.</p> <ul style="list-style-type: none"> • Solid GREEN – Wireless connection is established. • Flashing GREEN – Data transmission is in progress. • Off – Wireless connection is disabled.

No.	LED	Description
4	3G or WPS LED	Lights up to indicate the Wi-Fi Protected Setup (WPS) connection status. <ul style="list-style-type: none">• Solid GREEN – WPS-enabled device is connected.• Flashing GREEN – 3G card is connected and data transmission is in progress.• Flashing RED – WPS or 3G connection failed.• Off – WPS is disabled or no 3G card is connected.
5	Broadband (DSL) LED	Lights up to indicate DSL connection status. <ul style="list-style-type: none">• Flashing GREEN (slow) – DSL line detection in progress.• Flashing GREEN (fast) – Attempts to synchronize with DSL line.• Solid GREEN – DSL connection is established.• Off – DSL connection is not present.
6	Internet LED	Lights up to indicate Internet connection status. <ul style="list-style-type: none">• Solid GREEN – Internet is connected but no activity.• Flashing GREEN – Data transmission is in progress.• Solid RED – Internet connection failed.• Off – No internet connection.

1.3.2 Rear Panel

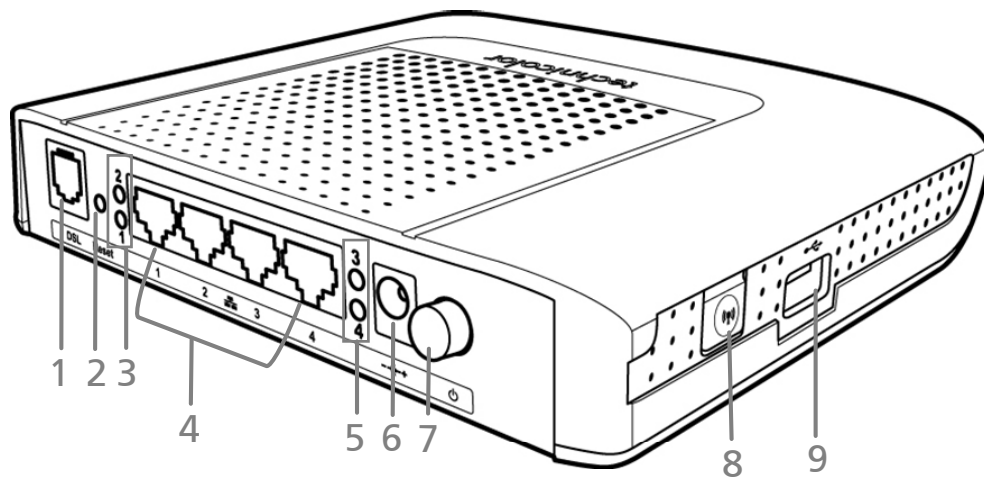

No.	Ports / Buttons	Description
1	DSL port	Connects to the DSL line using the RJ-11 cable.
2	Reset button	Press and hold this button for at least 10 seconds to restore your device to its original factory default setting.
3	LAN LED 1, 2	The LAN LED (1, 2) lights up when a device is connected to the Ethernet port (1, 2).
4	Ethernet port 1, 2, 3, 4	Connects a computer and other Ethernet network devices to the Wireless Gateway using RJ-45 cables.
5	LAN LED 3, 4	The LAN LED (3, 4) lights up when a device is connected to the Ethernet port (3, 4).
6	DC In jack	Connects to the power adapter.
7	Power button	Press to turn your device on or off.
8	WPS button	Press to enable the WLAN. Press and hold for at least 8 seconds to enable WPS.
9	USB Port	Connects to USB flash drives or 3G dongle.

Chapter 2: Installation

Make sure that all devices are powered off before starting installation.

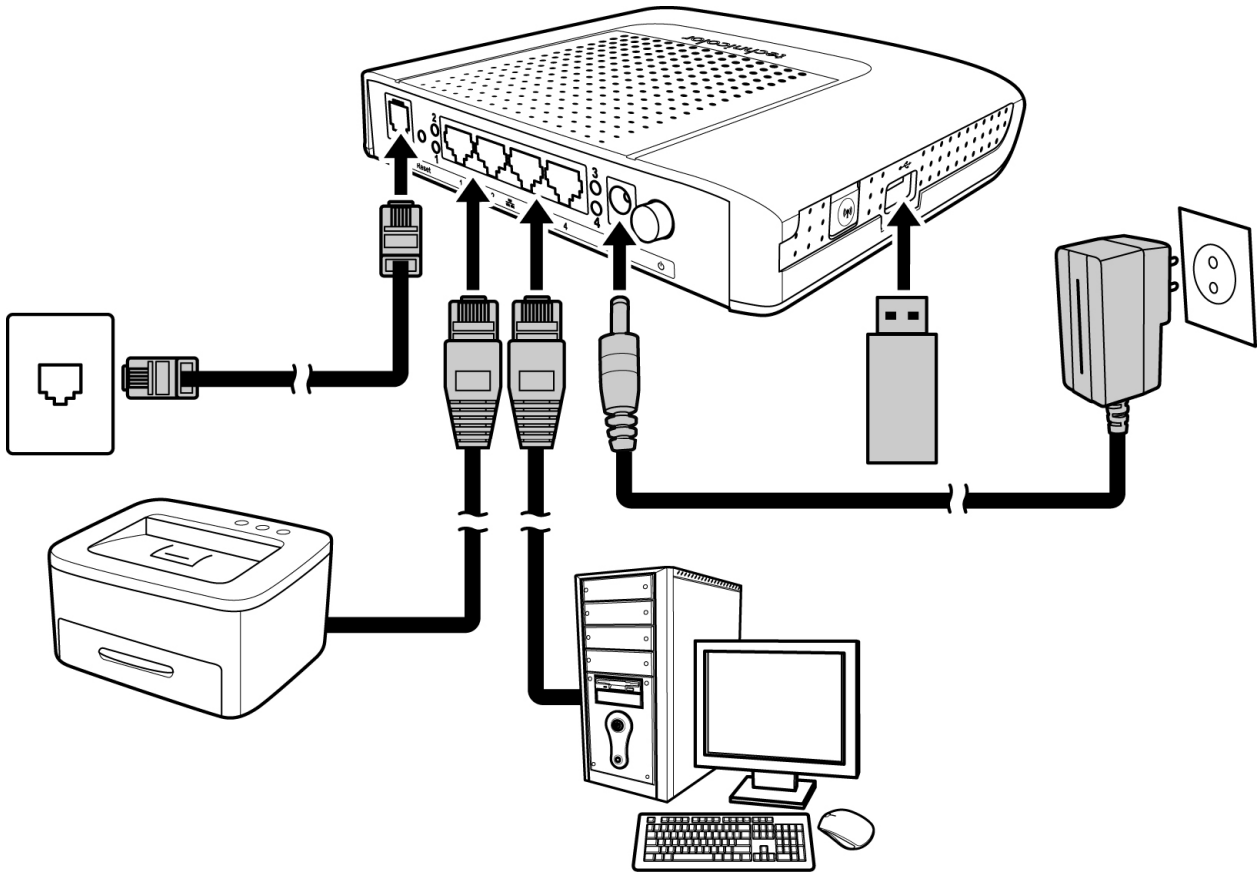

Installation Diagram

2.1 Connect the Power

1. Connect the power adapter to the DC In jack of your Wireless Gateway.
2. Plug the power adapter to a wall outlet or a power strip.

NOTE:

- Use only the supplied power adapter. Using other power adapters may cause damage to the device.
- Connect all devices to your Wireless Gateway before connecting the power adapter to a wall outlet.

2.2 Connect Wired Devices

Connect devices such as computers, printers, and other Ethernet-enabled devices to the LAN port of the Wireless Gateway.

NOTE:

When setting up the Wireless Gateway for the first time, connect the host computer via Ethernet connection.

1. Connect one end of the RJ-45 cable to one of the Ethernet (1, 2, 3, 4) ports of your Wireless Gateway.
2. Connect the other end of the RJ-45 cable to the Ethernet port of the computer.
3. Repeat the above steps to connect other computers to the Wireless Gateway via Ethernet connection.
4. To connect more than four computers, use a hub or switch. Connect one end of an RJ-45 cable to the hub or switch and the other end to the computer.

2.3 Connect Wireless Devices

Before connecting wireless devices to the Wireless Gateway, configure the wireless security settings of your Wireless Gateway (see “**Error! Reference source not found.**” on page **Error! Bookmark not defined.**). Take note of the SSID and the password you have set, you need the SSID and the password to connect devices to your Wireless Gateway.

2.3.1 WLAN

From the wireless device end, search for the Wireless Gateway network name (SSID), and enter the passphrase to connect.

NOTE:

The SSID and passphrase are the ones you have set in the Wireless Security Settings (see “**Error! Reference source not found.**” on page **Error! Bookmark not defined.**).

2.3.2 Wi-Fi Protected Setup (WPS)

Press and hold the **WPS** button of the Wireless Gateway for at least 8 seconds and press the WPS button on the WPS-enabled device to start pairing.

2.4 Connect the Broadband (DSL)

1. Connect one end of the RJ-11 cable to the DSL port of your Wireless Gateway.
2. Connect the other end of the RJ-11 cable to a wall jack with DSL service.

2.4.1 Use a Splitter

You need a splitter when connecting the Wireless Gateway to the wall jack that also connects to a telephone.

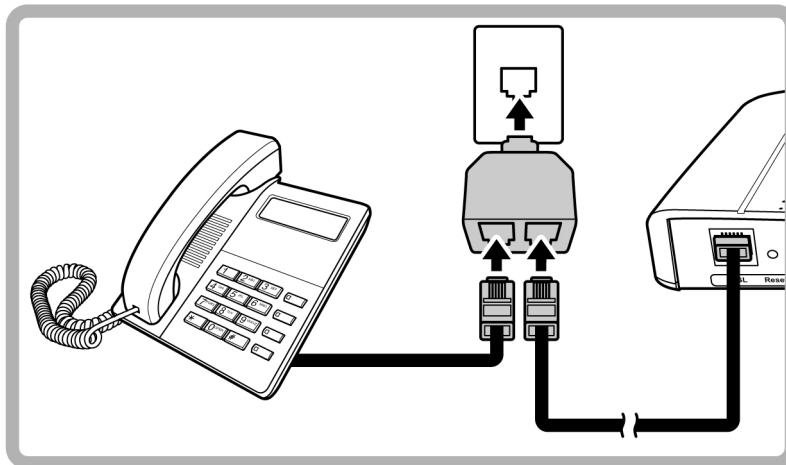

1. Plug the splitter to the wall jack with DSL service.
2. Connect one end of the RJ-11 cable to the DSL port of your Wireless Gateway.
3. Connect the other end of the RJ-11 cable to the MODEM port of the splitter.
4. Connect the telephone to the LINE port of the splitter using another RJ-11 cable.

2.5 Check the Installation

To ensure that all devices are properly connected, check the LED indicators on the front of your Wireless Gateway. For basic installation, the following LEDs must be lit:

- √ Power LED
- √ Ethernet LED
- √ DSL LED

The lighted LED indicators vary depending on the type of connection that you make. See "Front Panel" on page 7 for more information about the LED indicators.

Chapter 3: Configure the Computer

This chapter will guide you on how to configure your computer according to the operating system you are using.

Windows® XP, see below.

Windows® Vista, see page 16.

Windows® 7, see page 16.

3.1 Windows XP

If you are using Windows® XP, follow the instructions below to configure your computer.

1. Click Start > Control Panel > Network Connections.
2. Right-click Local Area Connection, then click Properties.
3. On the network components list, make sure that **Internet Protocol (TCP/IP)** is checked. If not, check it to enable the **Properties** button.
4. Select Internet Protocol (TCP/IP), and then click Properties.
5. On the General tab, select Obtain an IP Address automatically and Obtain DNS server address automatically.
6. Click **OK**.

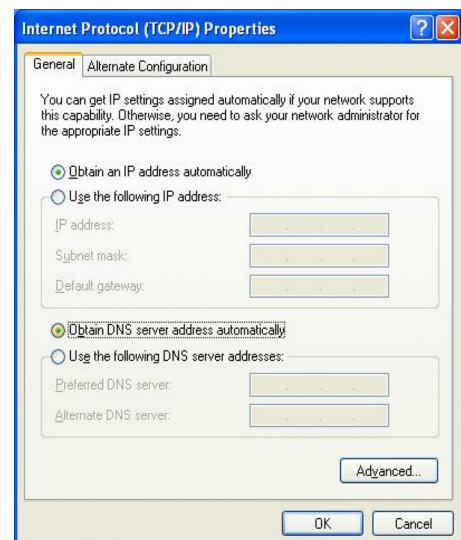

General Page

3.2 Windows Vista

If you are using Windows® Vista, follow the instructions below to configure your computer.

1. Click Start > Control Panel > Network and Internet Connections > Network Connections.
2. Right-click Local Area Connection, then click Properties.
3. On the General tab, make sure that **Internet Protocol (TCP/IP)** is checked. If not, check it to enable the **Properties** button.
4. Select Internet Protocol (TCP/IP), and then click Properties.
5. Select Obtain an IP Address automatically and Obtain DNS server address automatically.
6. Click **OK**.

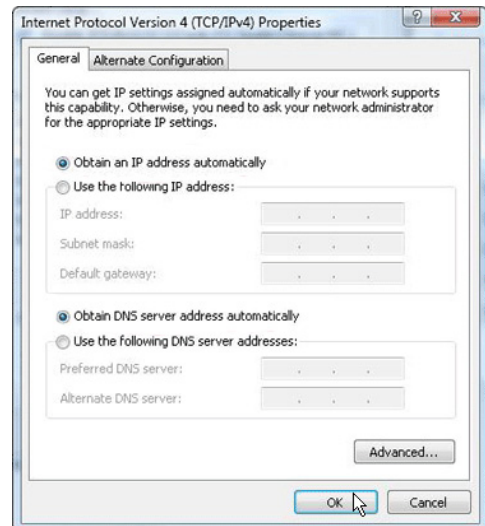

General Page

3.3 Windows 7

If you are using Windows® 7, follow the instructions below to configure your computer.

1. Click Start > Control Panel > Network & Sharing Center.
2. Click Local Area Connection.
3. Click Properties.
4. On the network components list, make sure that **Internet Protocol (TCP/IP)** is checked. If not, check it to enable the **Properties** button.
5. Select Internet Protocol (TCP/IP), and then click Properties.
6. On the General tab, select Obtain an IP Address automatically and Obtain DNS server address automatically.
7. Click **OK**.

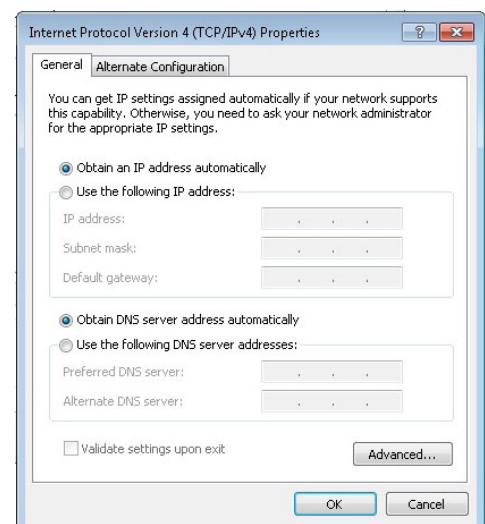

General Page

Chapter 4: Access the Wireless Gateway

Use the Web Configurations utility to configure your Wireless Gateway.

4.1 Initial Setup

1. Launch the web browser.

When your Wireless Gateway is successfully connected to the computer, the web browser is automatically directed to the default IP address of your Wireless Gateway.

The **Not Connected** screen appears.

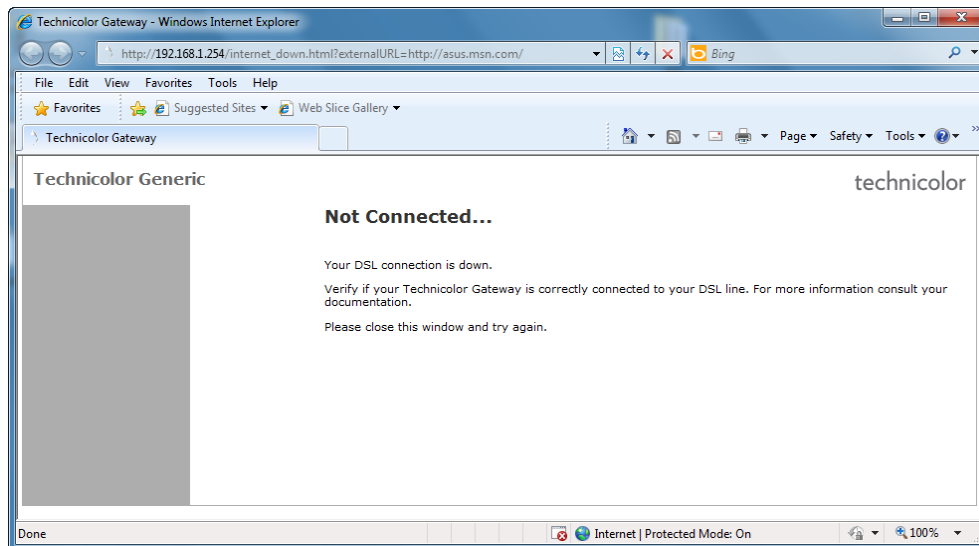

2. On the address bar, type <http://192.168.1.254> then press **Enter**. The **Login** screen appears.

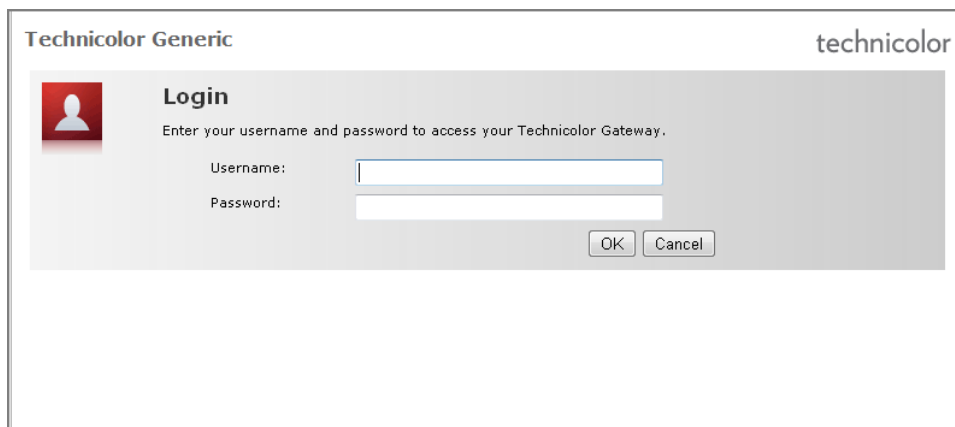

3. Type the **Username** and **Password**, default values are "tech".

NOTE:

- If the Web Configurations utility has been left idle for some minutes, the system may prompt you to login again; enter the **User name** and **Password**. The default user name and password is "tech". It is advised to change the password, see "Error! Reference source not found." on page Error! Bookmark not defined..

4. The **Welcome** screen appears. Click on **Set up my Technicolor Gateway**. It is recommended to follow the wizard to set up the network and configure the **Wireless Gateway**.

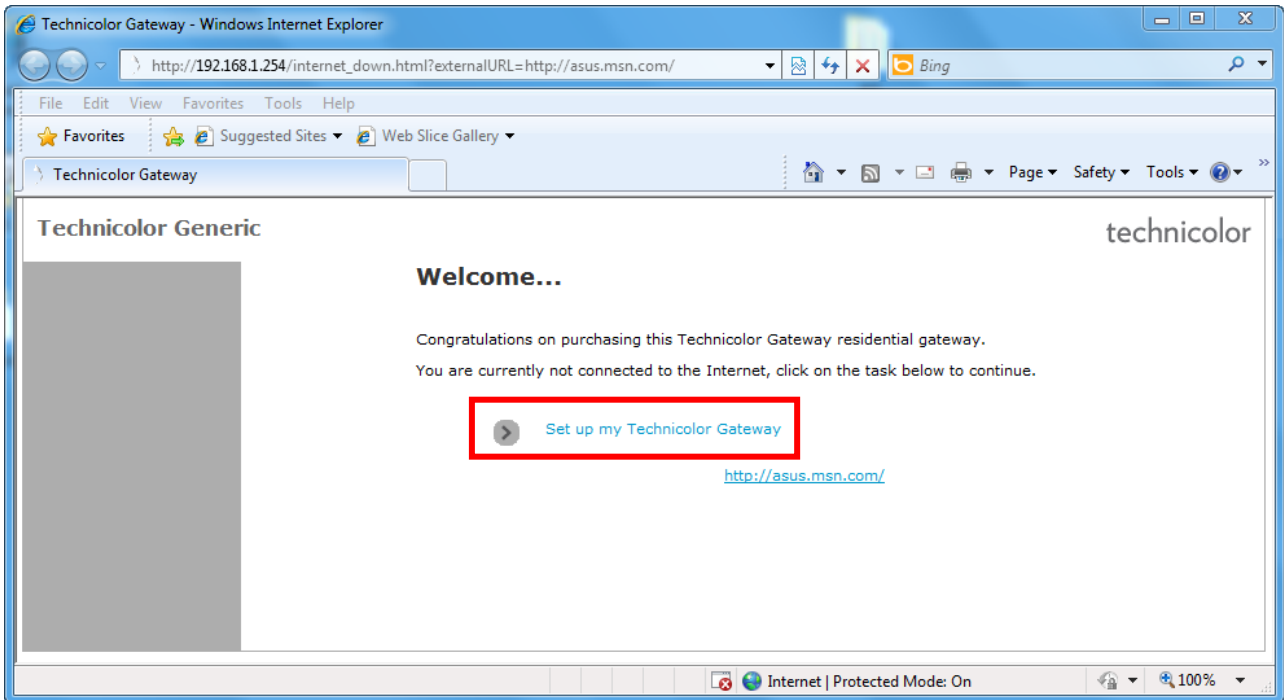

5. The **Technicolor Wizard** screen appears. Click **Next** to continue.



NOTE:

- The required information on the succeeding screens must be obtained from your Internet Service Provider (ISP).

6. Select the DSL account service: **Bridge** or **Routed PP**, and then click **Next**.

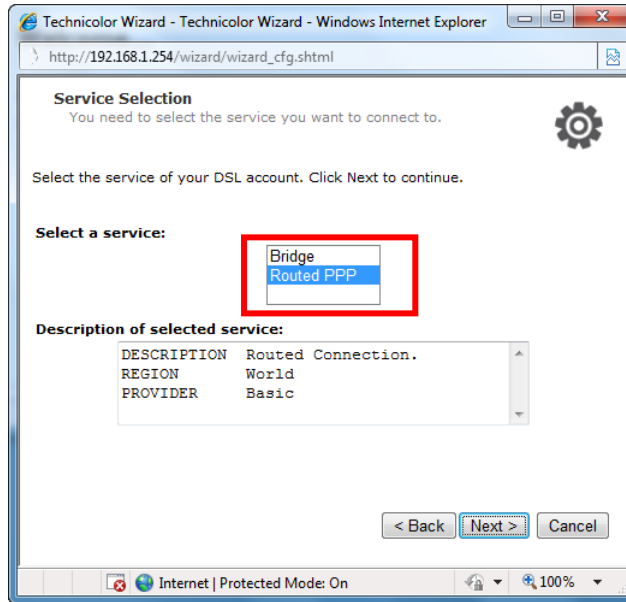

7. If you select **Routed PPP**, skip to step 8.

If you select, **Bridge**, do the following:

a. Select the **VPI/CI**, and then click **Next**.

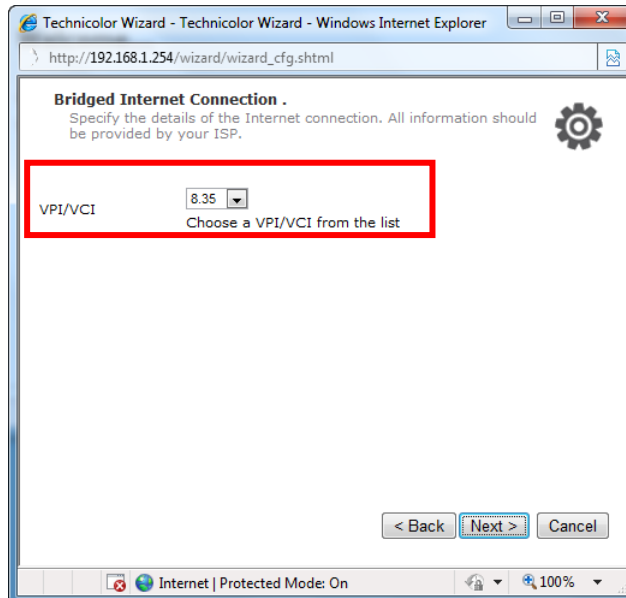

- b. If your network is using a DHCP server, keep the **DHCP Server** box checked, if not, remove it.

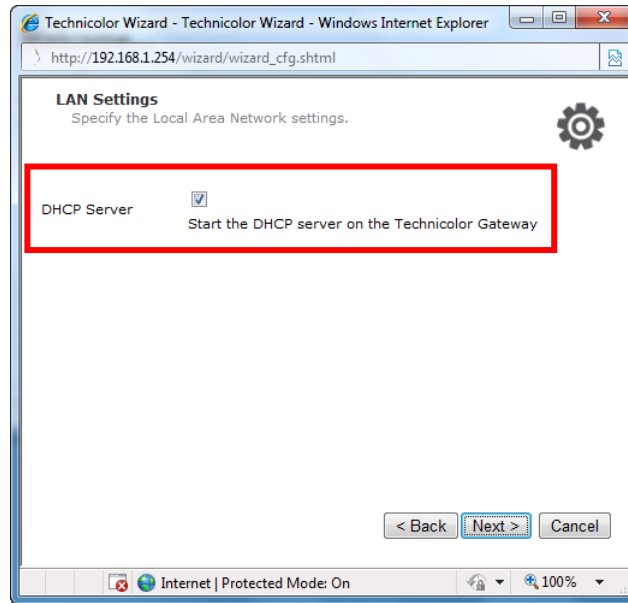

- c. Click **Next** to continue. Then, skip to step 9.
8. If you select **Routed PPP**, do the following:
- a. Select the **VPI/VCI** and **Connection Type**, and then click **Next**.

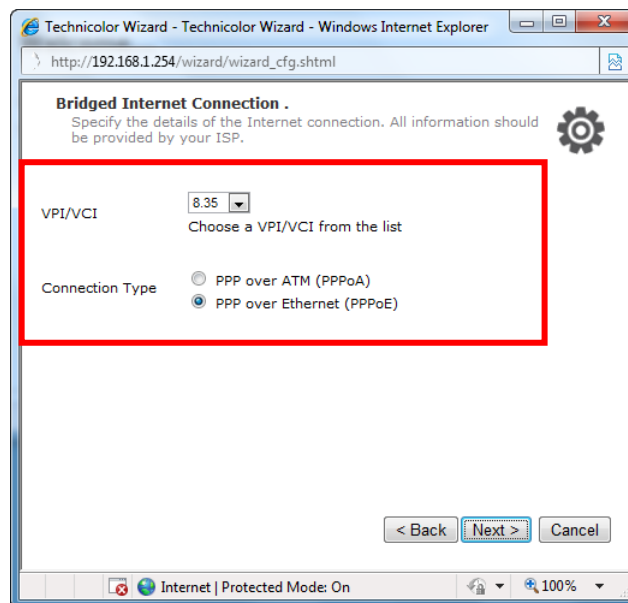

- b. The **Internet Account Settings** screen appears. Obtain the necessary information from your ISP.

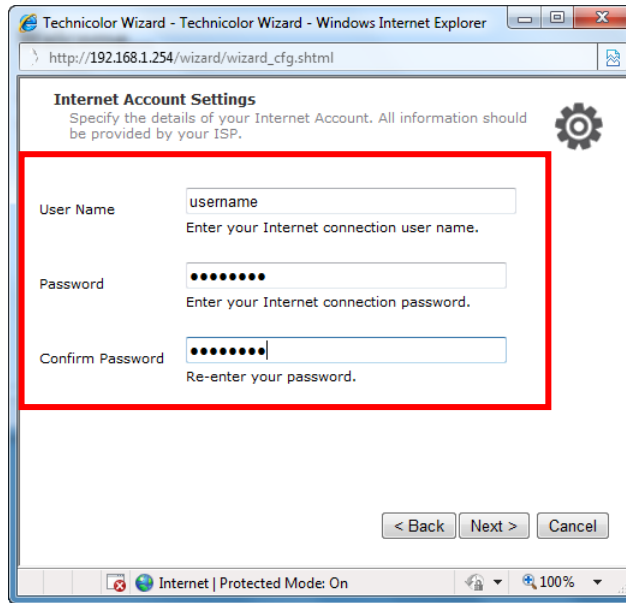

- c. Type your Internet account user name in **User Name**.
 - d. Type your account password in **Password** and **Confirm Password**.
 - e. Click **Next** to continue.
9. The **Access Control** screen appears. Create your access control account that you will use to login to the web configuration utility. To create the access control account, do the following:
- a. Type the administrator account name in **User Name**.
 - b. Type the login password in **Password** and **Confirm Password**.

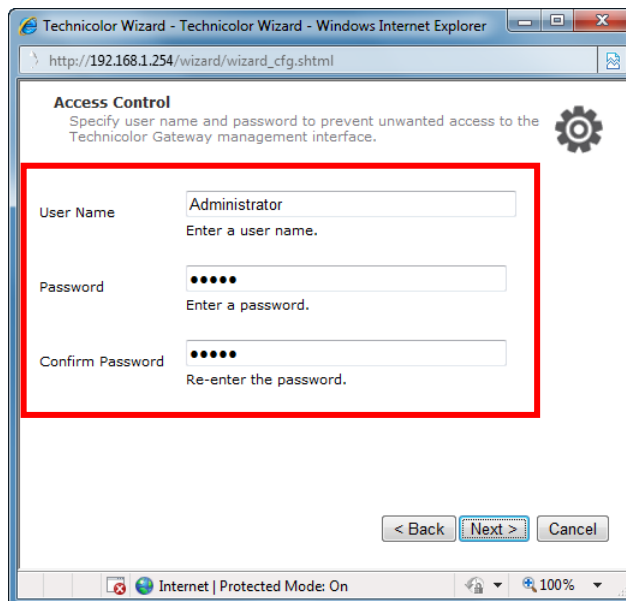

10. Click **Next** to continue.

11. Review your Wireless Gateway settings, and then click **Start** to apply the settings.

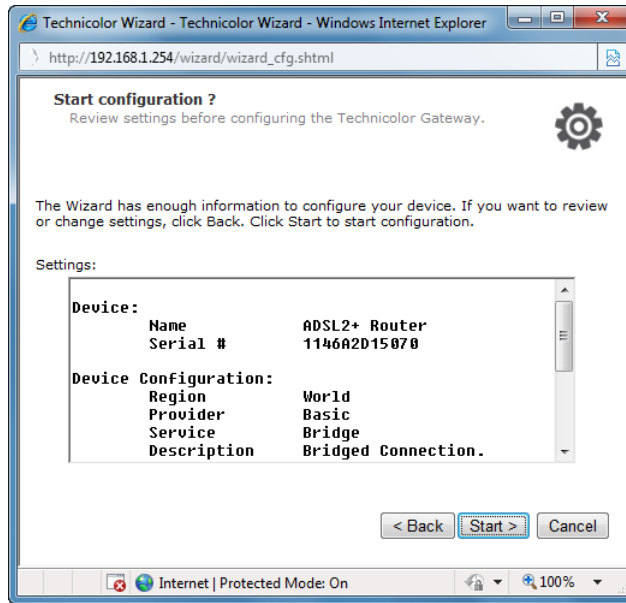

12. The configuration may take a while to finish. When complete, click **Finish**.

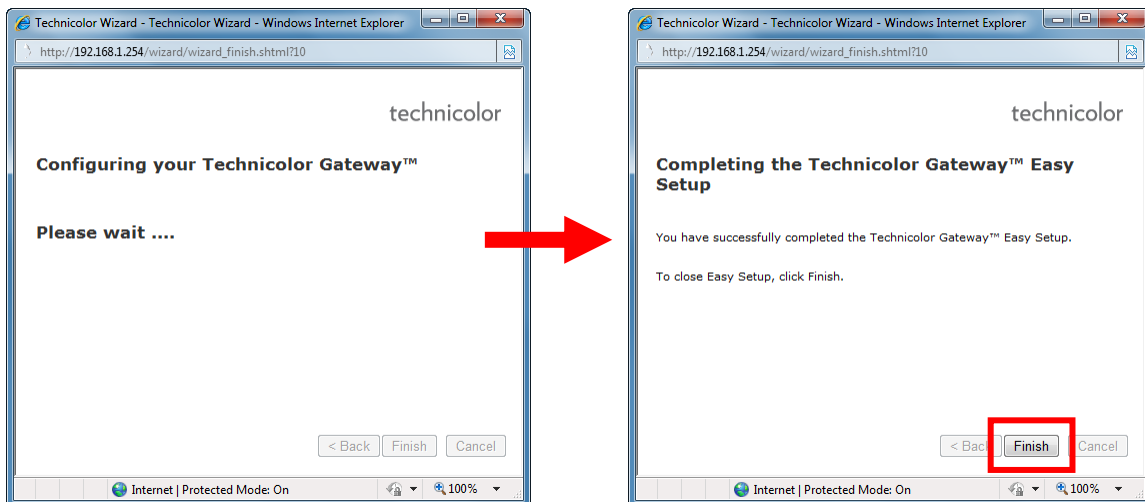

13. Close the web browser.

4.2 Login

For more advanced configuration, access the Technicolor web configuration utility.

1. Launch the web browser.
2. On the address bar, type <http://192.168.1.254>, and then press **Enter**.
3. Login with the user name and password you set in the initial setup.
4. Click **OK**.

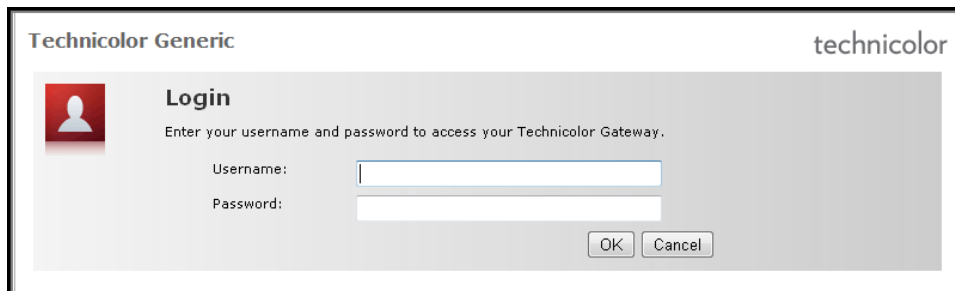

4.3 The Interface

Once logged in, the **Home** screen appears. The **Home** screen provides quick access to the most common functions of your Wireless Gateway. Click an option to access the function.

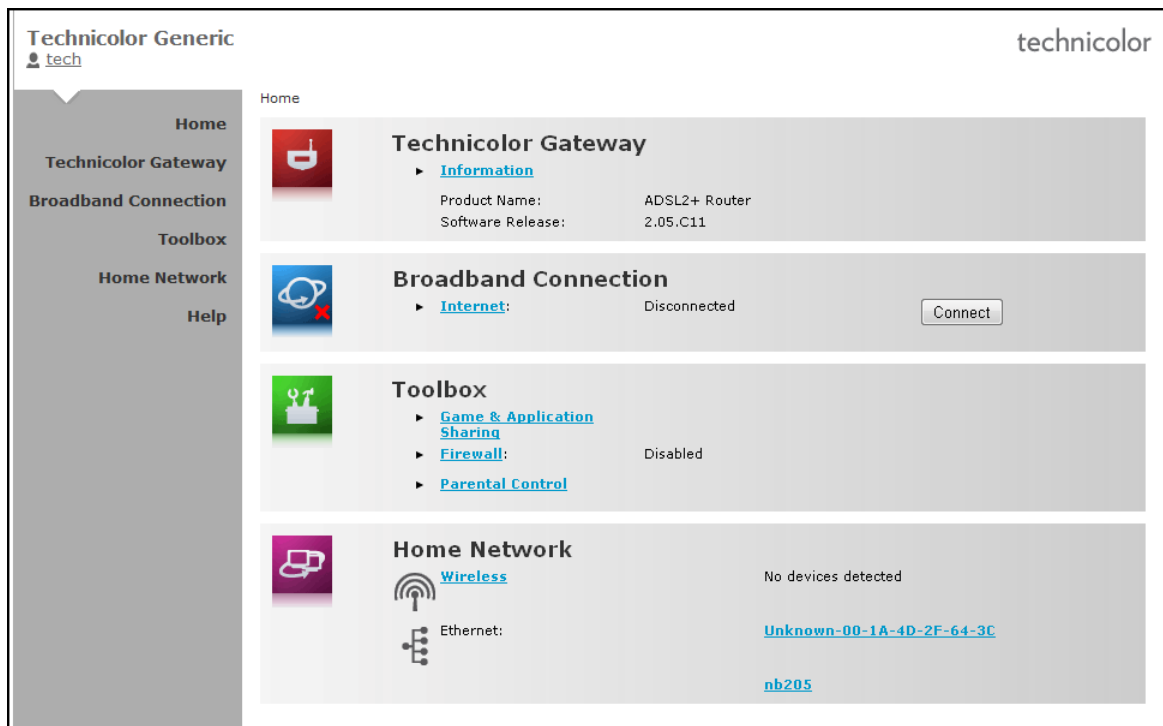

In some screens, shortcut items are available on the bottom of the screen. Click a shortcut to access the page. See example below.

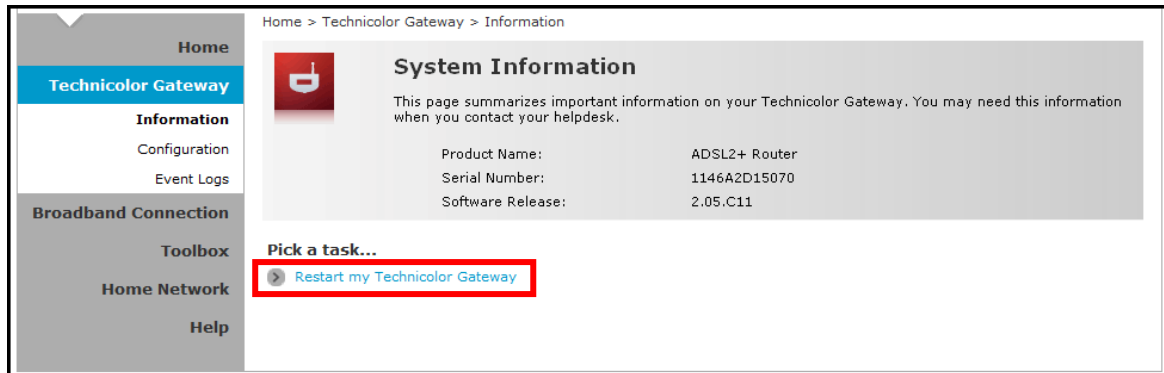

4.4 Using the Menu

For more advanced users, use the main menu, located on the left panel of the screen, to configure your Wireless Gateway.

Click a menu item, then a submenu to display the page.

The following menu items are available:

- **Home** — Displays the Home screen.
- **Technicolor Gateway** — Allows you to configure your Wireless Gateway, such as system date and time, and to view event logs.
- **Broadband Connection** — Allows you to view the DSL connection status of your Wireless Gateway and configure a dial-up connection and establish or terminate the Internet connection.
- **Toolbox** — Allows you to configure more advanced functions, such as remote assistance, firewall, filter, parental control services, and others.
- **Home Network** — Allows you to view the devices connected to the network of your Wireless Gateway.

Chapter 5: Technicolor Gateway

The **Technicolor Gateway** menu allows you to view the system information and configure the Wireless Gateway. This menu is divided into three sections: **Information**, **Configuration**, and **Event Logs**.

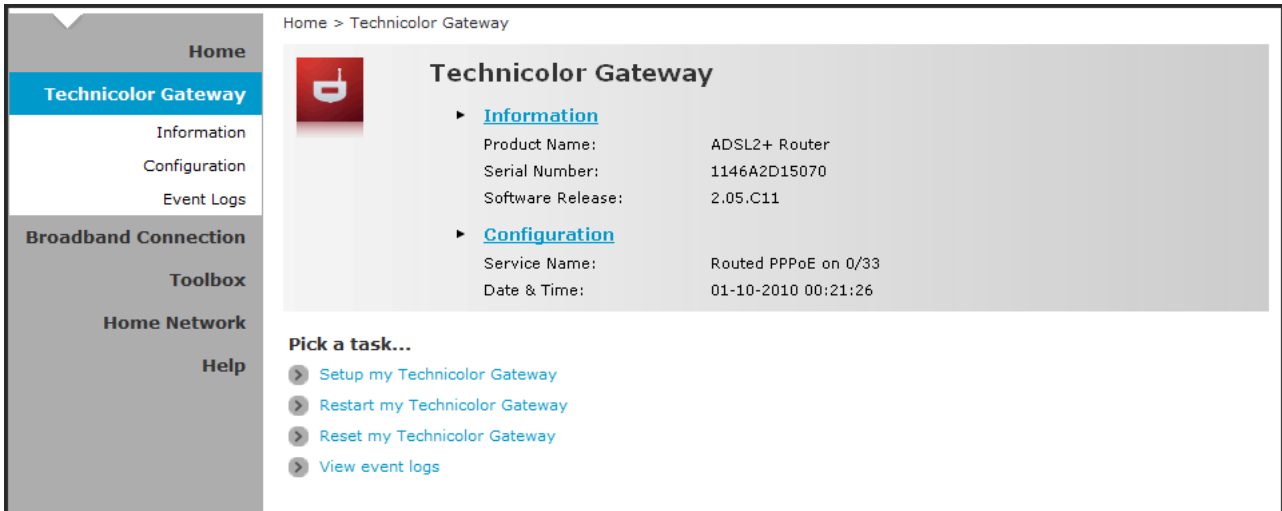

5.1 System Information

The System Information page displays the product name, device serial number, and software release information. To view the **System Information** page, do one of the following:

- On the main menu, click **Technicolor Gateway > Information**.
- From the **Home** screen, click **Information**.

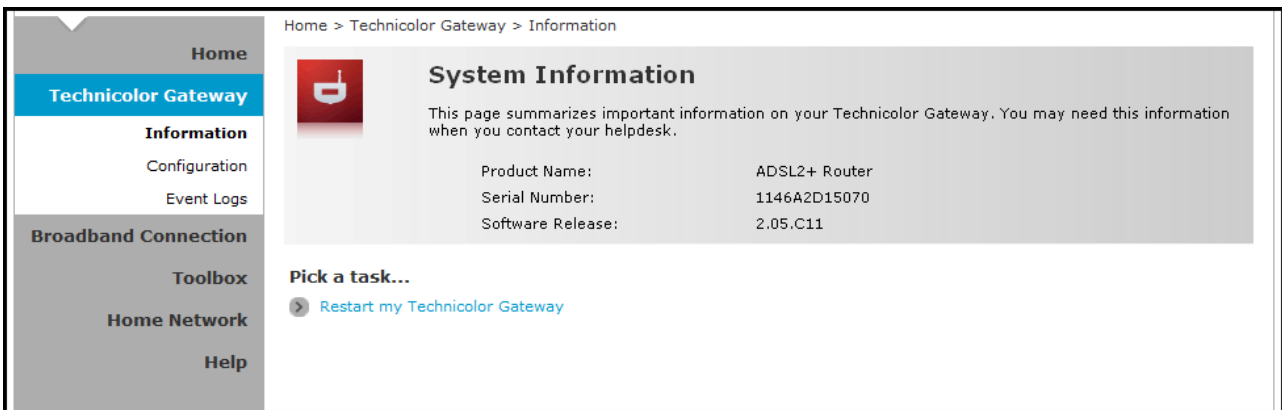

5.2 System Configuration

The **System Configuration** page allows you to configure the Internet service and the system date and time, and enable web browsing interception.

To view the **System Configuration** page, click **Technicolor Gateway > Configuration**.

To modify the system configuration, click **Configure**.

5.2.1 DSL Service Configuration

To modify the DSL service configuration, click **Configuration Wizard** and then follow the instructions on the screen. See "4.1 Initial Setup on page 15".

5.2.2 Date and Time Configuration

To modify the time configuration, do the one of following:

Manual Configuration

To manually set the date and time, enter the date and time values in the corresponding fields. Select a **Timezone** or enable **Summer Time** for applicable areas.

Auto Configuration

To synchronize the date and time with a time server, do the following:

1. Check the **Auto-configuration** box.
2. Enter the values of the applicable items in your location:
 - **Timezone** — Enter the time zone in your location.
 - **Summer Time** — Check if summer time is applicable in your location.

3. Enter the time server to sync the Wireless Gateway with. You can type up to five timer servers.
4. Click **Apply** to save changes.

5.2.3 Web Browsing Interception

1. On the Web Browsing Interception box, select one of the following:
 - **Enabled** (default) — To enable web browsing interception.
 - **Disabled** — To disable web browsing interception. When disabled, address based filtering is also disabled.
2. Click **Apply** to save changes.

5.3 Event Logs

The **Event Logs** page allows you to view and clear system logs.

To access the **Event Logs** page, click **Technicolor Gateway > Event Logs**.

Home > Technicolor Gateway > Event Logs

Event Logging

This page summarizes the last events that have been recorded on your Technicolor Gateway. Choose a display filter...

Category:

▶ **Recorded Events**

	Time	Message
	2010-10-01 00:00:08	Boa/0.93.15 started
	2010-10-01 00:00:05	DHCP server up
	2010-10-01 00:00:04	DHCP server went down!
	2010-10-01 02:03:01	syslogd exiting
	2010-10-01 02:02:59	reading /etc/resolv.conf
	2010-10-01 02:02:58	unrecognized option 'nic-vc0_e_0_33'
	2010-10-01 02:02:57	Password for 'admin' changed
	2010-10-01 02:02:57	The admin's password has been changed.
	2010-10-01 02:02:57	The Administrator's name has been changed to admin.
	2010-10-01 00:00:07	Boa/0.93.15 started
	2010-10-01 00:00:05	DHCP server up
	2010-10-01 00:00:04	DHCP server went down!

Pick a task...

[Clear the event log](#)

You can filter the list by selecting a category from the drop-down lists.

The log is automatically refreshed every 10 seconds.

To clear the log, click **Clear the event log** on the bottom of the page.

Chapter 6: Broadband Connection

The **Broadband Connection** menu allows you to view and modify the Internet service configuration of your Wireless Gateway. This menu is divided into two sections: **DSL Connection** and **Internet Services**.

To view the **Broadband Connection** page, click **Broadband Connection**.

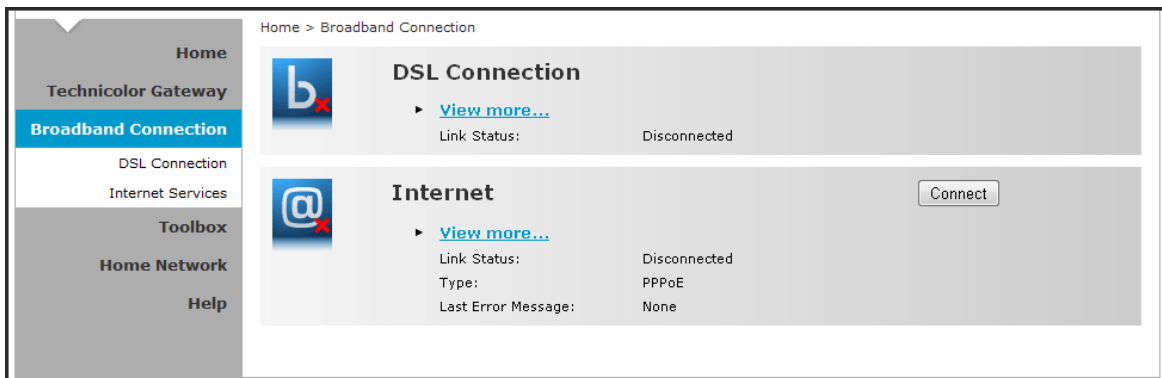

6.1.1 DSL Connection

To view the DSL connection status, do one of the following:

- On the **Broadband Connection** page, click **View more** under **DSL Connection**.
- On the main menu, click **Broadband Connection > DSL Connection**.

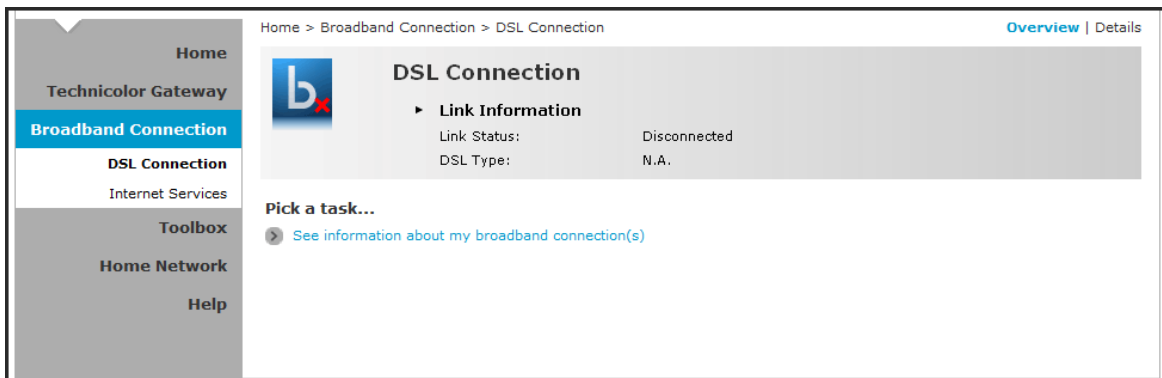

NOTE:

DSL connection cannot be modified from this point. To modify the DSL connection, see "5.2.1 DSL Service Configuration on page 24".

6.1.2 Internet Services

Use the **Internet Services** page to configure the settings and connect to the Internet. To view the **Internet** page, do one of the following:

- From the **Home** screen, click **Internet**
- On the **Broadband Connection** page, click **View more** under **Internet**
- On the main menu, click **Broadband Connection > Internet Services > View More**

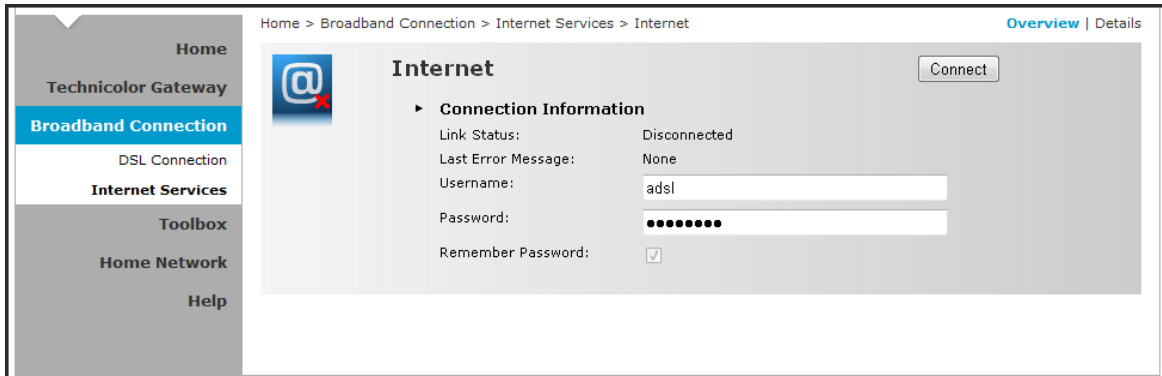

- To connect to the Internet, click **Connect**.
- To modify the account username and password, re-type the information on the corresponding boxes, and then click **Connect**.
- To view more connection details, click **Details** on the upper corner of the page.

Chapter 7: Toolbox

The **Toolbox** menu allows you to protect your network, share games and applications with other people on the Internet, and manage your local network. This menu is divided into eight sections: **Remote Assistance**, **Game & Application Sharing**, **Parental Control**, **Firewall**, **Intrusion Detection**, **Dynamic DNS**, **User Management**, and **Content Sharing**.

To view the **Toolbox** page, click **Toolbox** on the main menu.

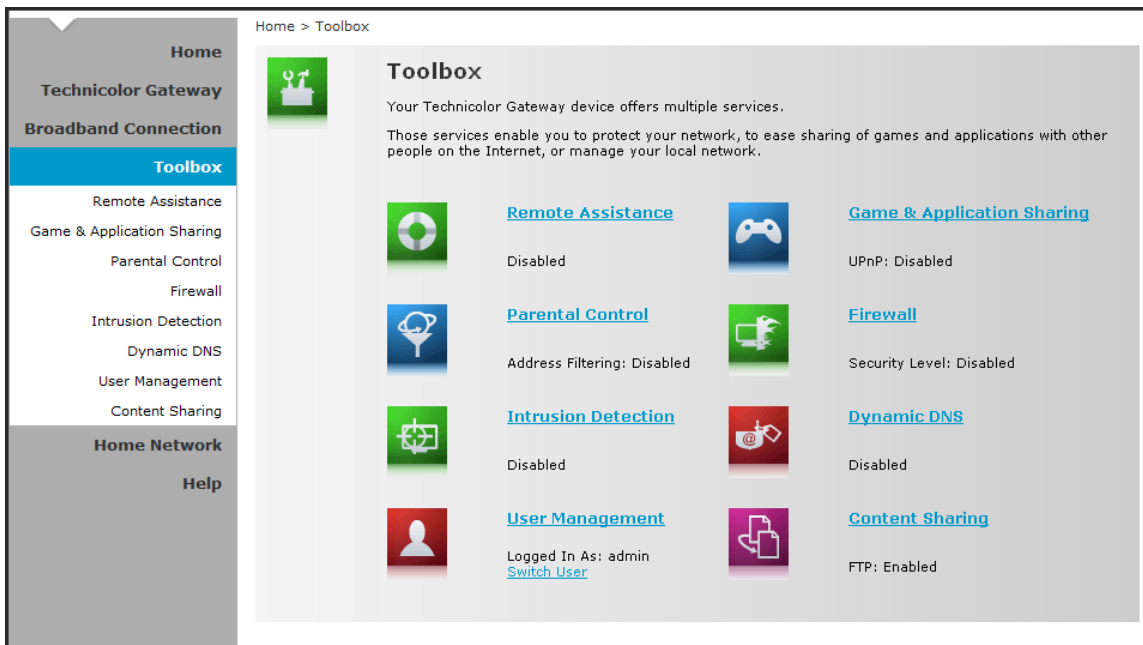

7.1 Remote Assistance

NOTE:

To enable remote assistance, you must be connected to the Internet.

The **Remote Assistance** page allows you to make your Wireless Gateway remotely accessible.

7.1.1 Enable Remote Assistance

1. Select the remote assistance **Mode**:
 - **Permanent Mode** — Once remote assistance is enabled, the remote session only ends when users disable this feature or when the Wireless Gateway is restarted.
 - **Temporary Mode** — The remote session automatically ends after 20 minutes of inactivity.
2. Enter the URL address to use to remotely access your Wireless Gateway.
3. Take note of the automatically generated User Name and Password that will be used to access your Wireless Gateway remotely. If desired, modify the password.
4. Check **Enable Remote Assistance** to enable this function.
5. Click **Apply** to save changes.

NOTE:

- Only one remote session is allowed at a time.
- The Wireless Gateway also supports dynamic DNS host names for remote access. See “Dynamic DNS” section.

7.1.2 Disable Remote Assistance

Click **Disable Remote Assistance** to disable this function.

7.2 Game & Application Sharing

The **Game & Application Sharing** page allows you to create new games and applications and assign games or applications to the network devices.

To view the **Game & Application Sharing** page, do one of the following:

- From the **Home** screen, click **Game & Application Sharing** under **Toolbox**.
- On the main menu, click **Toolbox > Game & Application Sharing**.

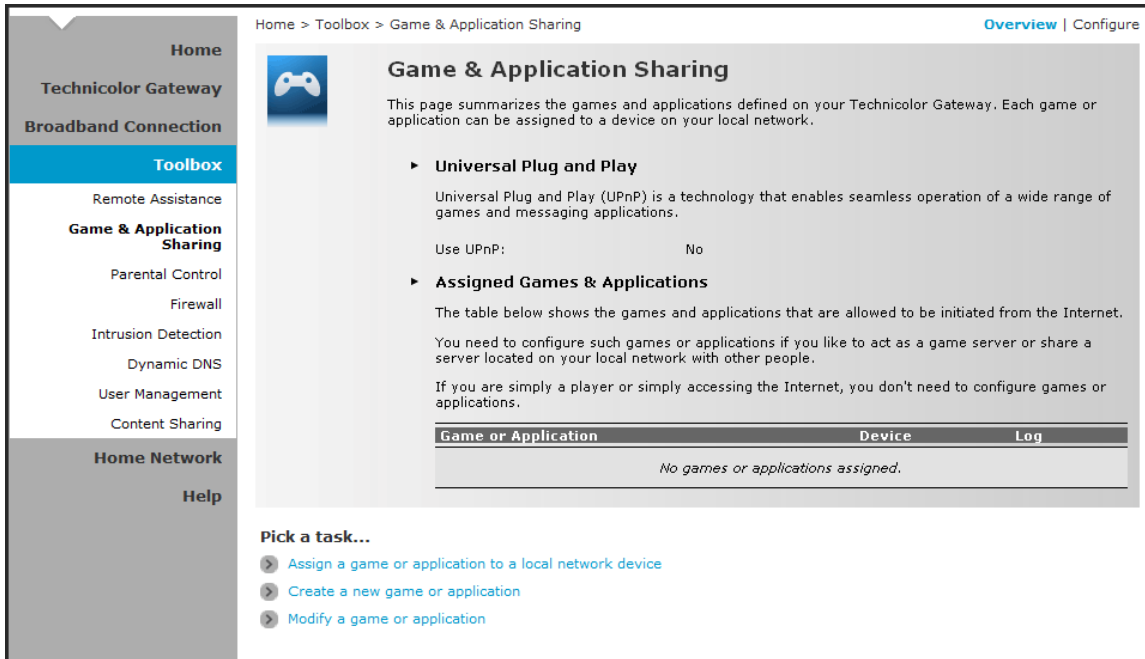

7.2.1 Assign a Game or Application

Your Wireless Gateway comes with predefined games and applications. Each game or application can be assigned to a network device.

- To assign a game or application, do one of the following:
 - Click **Configure** on the upper-right corner of the screen.
 - Click the **Assign a game or application to a local network device** shortcut at the bottom of the screen.

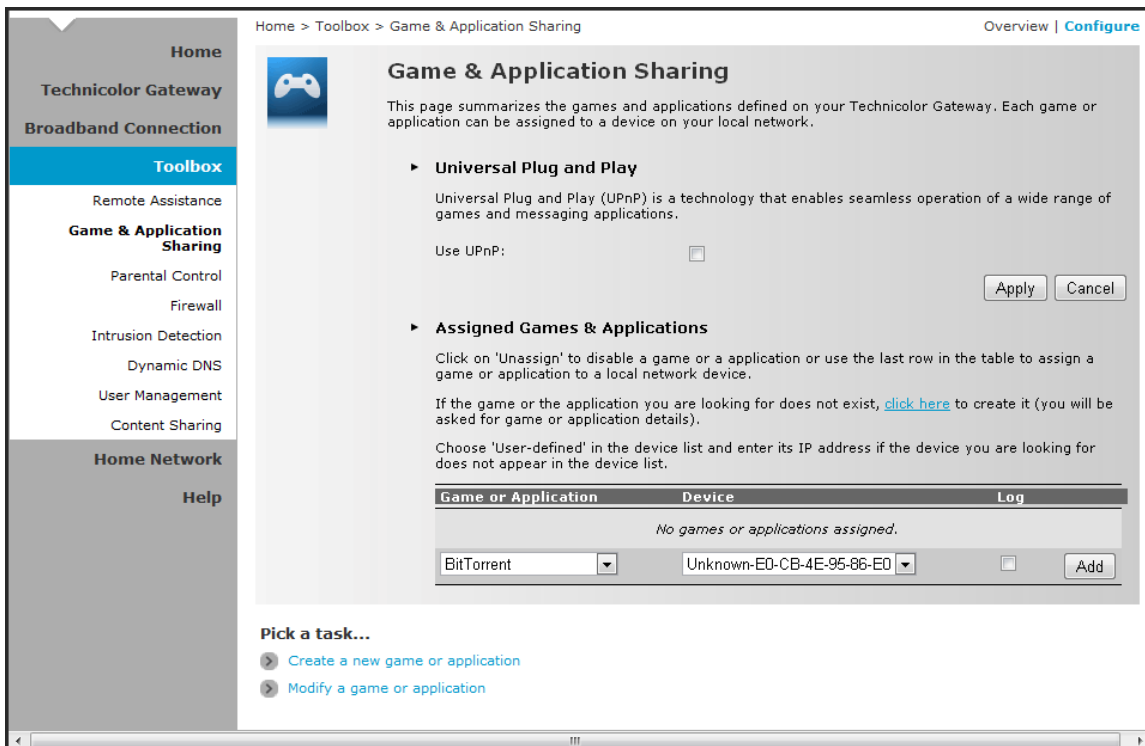

2. To enable Universal Plug and Play (UPnP) function, check the **Use UPnP** box, then click **Apply**.
3. On the **Assigned Games & Applications** table, select a game or application on the **Game or Application** field.
4. On the **Device** field, select the network device to assign the game or application to.
5. To log access, check the **Log** box.
6. Click **Add** to add the assigned entry to the table.

7.2.2 Modify Assigned Game or Application

1. On the main menu, click **Toolbox > Game & Application Sharing**.
2. From the **Game & Application** page, click **Customize** on the upper-right corner of the screen.

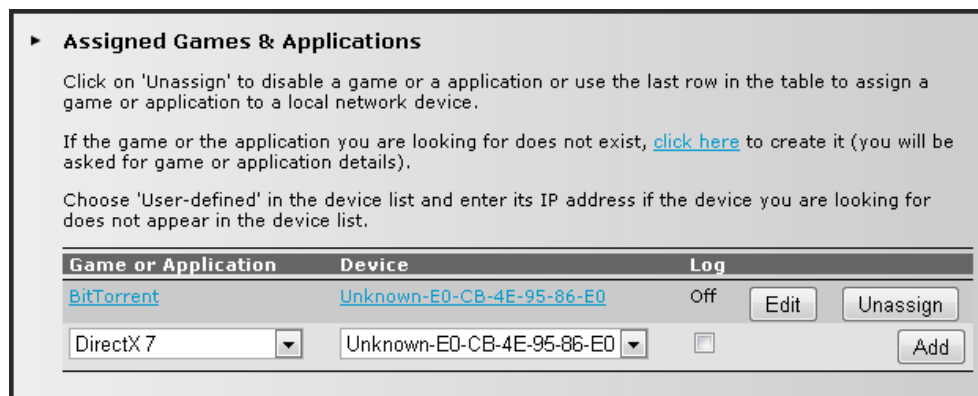

3. On the **Assigned Games & Applications** table, click the **Edit** button of the game or application you want to modify.
4. Modify the necessary info.
5. Click **Apply** to save changes.

7.2.3 Create a New Game or Application

If the game or application is not included in the predefined list, you need to create the game or application.

1. On the main menu, click **Toolbox > Game & Application Sharing**.
2. From the **Game & Application** page, click the **Create a new game or application** shortcut at the bottom of the screen.

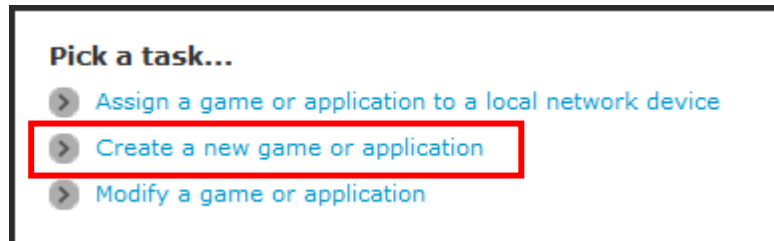

3. On **Name**, type the name of the game or application.

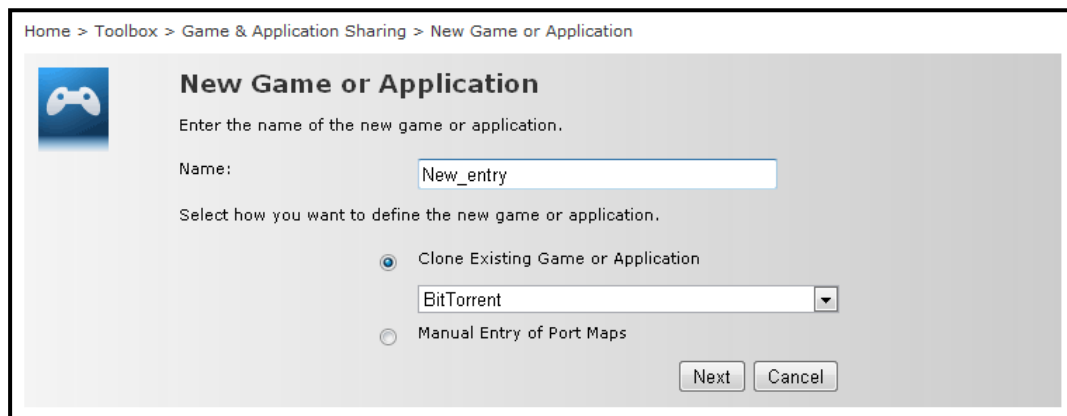
A screenshot of the 'New Game or Application' configuration page. The breadcrumb trail is 'Home > Toolbox > Game & Application Sharing > New Game or Application'. The page title is 'New Game or Application' with a game controller icon. Below the title, it says 'Enter the name of the new game or application.' There is a text input field labeled 'Name:' containing 'New_entry'. Below that, it says 'Select how you want to define the new game or application.' There are two radio button options: 'Clone Existing Game or Application' (which is selected) and 'Manual Entry of Port Maps'. Under the selected option, there is a dropdown menu showing 'BitTorrent'. At the bottom right, there are 'Next' and 'Cancel' buttons.

4. Select how you want to define the new game or application:
 - **Clone Existing Game or Application** — Select an existing game or application to clone its protocol and TCP/UDP port range settings.
 - **Manual Entry of Port Maps** — To manually select the protocol and enter the port range of the new game or application.
5. Click **Next** to continue.
6. If **Clone Existing Game or Application** is selected on step 4, skip to step 8.
7. If **Manual Entry of Port Maps** is selected on step 4, configure the parameters of the **Game or Application Definition** table. A preset incoming port range is set by the Wireless Gateway. You may add, edit, or delete this range. To add a TCP/UDP port range, do the following:

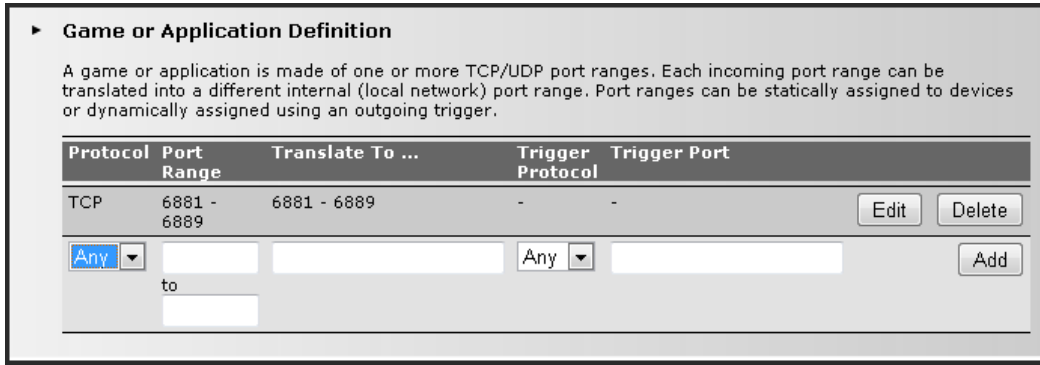

- a. Select the protocol.
 - b. Enter the incoming port range and the outgoing trigger port.
 - c. Click **Add** to save the settings.
8. Creating of game or application is complete.

7.2.4 Modify a Game or Application

1. On the main menu, click Toolbox > Game & Application Sharing.
2. From the **Game & Application** page, click the **Modify a game or application** shortcut at the bottom of the screen.

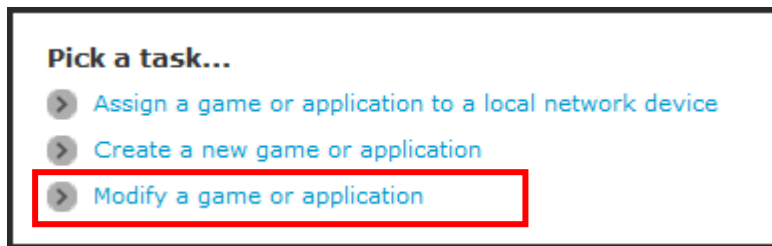

3. The list of games and applications appear. Click the **Edit** button of the game or application you want to modify.
4. Modify the necessary information.
5. Click **Apply** to save changes.

To delete a game or application, click the **Delete** button of the game or application you want to delete.

7.3 Parental Control

The Parental Control page allows you to filter web sites that a network device may access or be denied access.

To view the Parental Control page, do one of the following:

- From the **Home** screen, click **Parental Control** under **Toolbox**.
- On the main menu, click **Toolbox > Parental Control**.

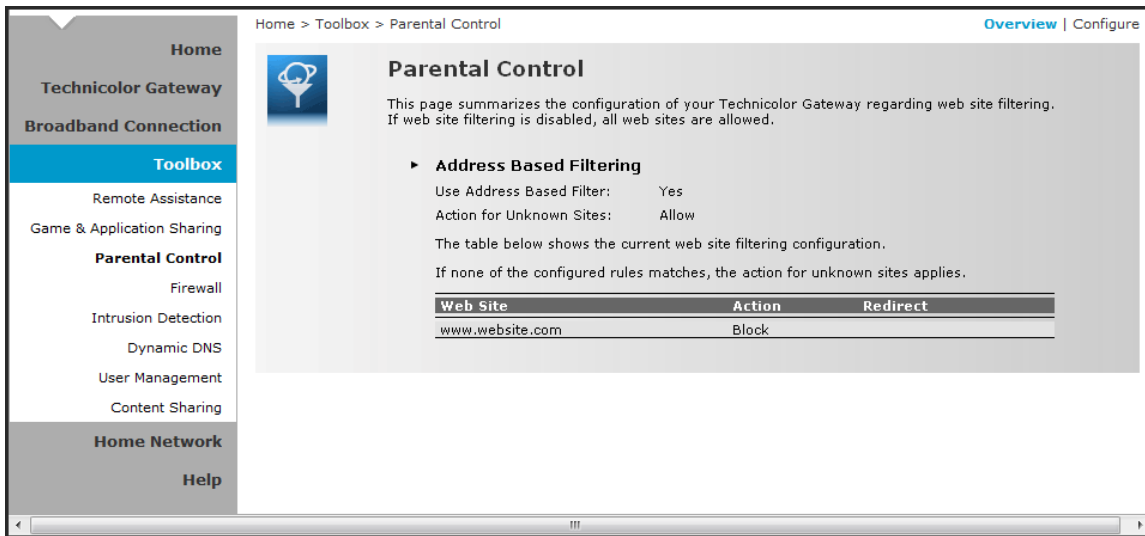

To configure parental control, click **Configure** on the upper-right corner of the screen.

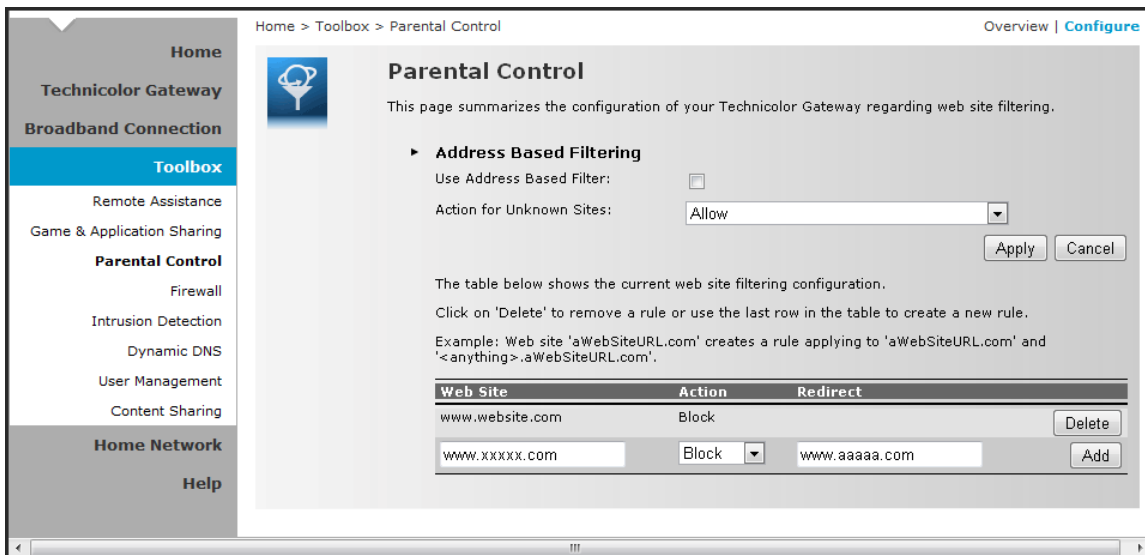

- **Use Address Based Filter** — Check to filter web sites by address.
- **Action for Unknown Sites** — Select whether to **Block** or **Allow** unknown sites.

Click **Apply** to save changes.

- **Web Site** — Enter the URL of the web site to block or allow.
- **Action** — Select one of the following options:
 - **Block:** To block the web site.
 - **Allow:** To allow access to the web site.
 - **Redirect:** To redirect to another web site if the web site defined on the Web Site field is being accessed.
- **Redirect** — If **Redirect** is selected in **Action**, enter the URL address to where you want to redirect the site.

Click **Add** to save the changes to the table.

7.4 Firewall

The **Firewall** page allows you to set the firewall security of your Wireless Gateway.

To view the **Firewall** page, do one of the following:

- From the **Home** screen, click **Firewall** under **Toolbox**.
- On the main menu, click **Toolbox > Firewall**.

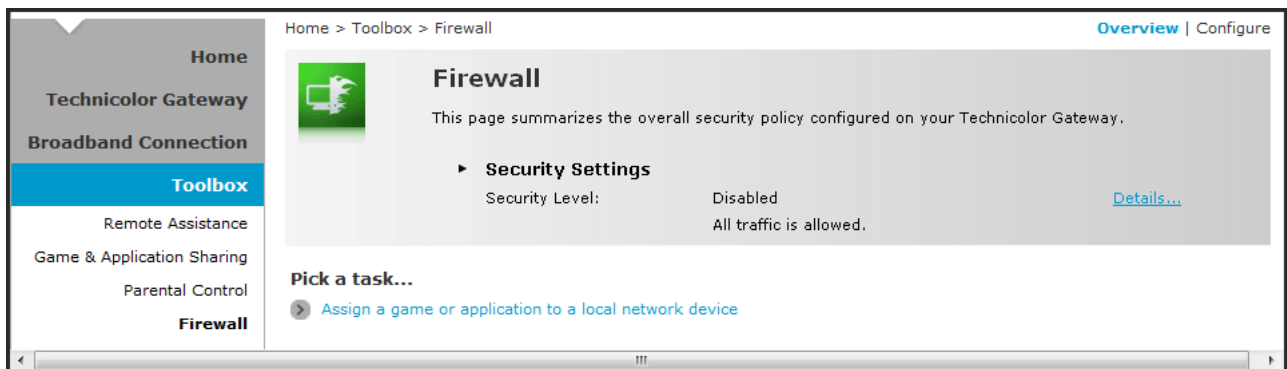

7.4.1 Change Firewall Security Level

1. On the **Firewall** page, click **Configure** on the upper-right corner of the screen.
2. Select the desired security level:
 - **Block All** — Block all traffic from and to the Internet.
 - **Standard** — Block all incoming traffic but allow outgoing traffic.
 - **Disabled** — Disable firewall security, all traffic is allowed.
3. Click **Apply** to save changes.

7.4.2 Create a New Security Level

1. On the **Firewall** page, click **Configure** on the upper-right corner of the screen.
2. Click the **Create a new Security Level** shortcut at the bottom of the screen. The **New Firewall Level** screen appears.

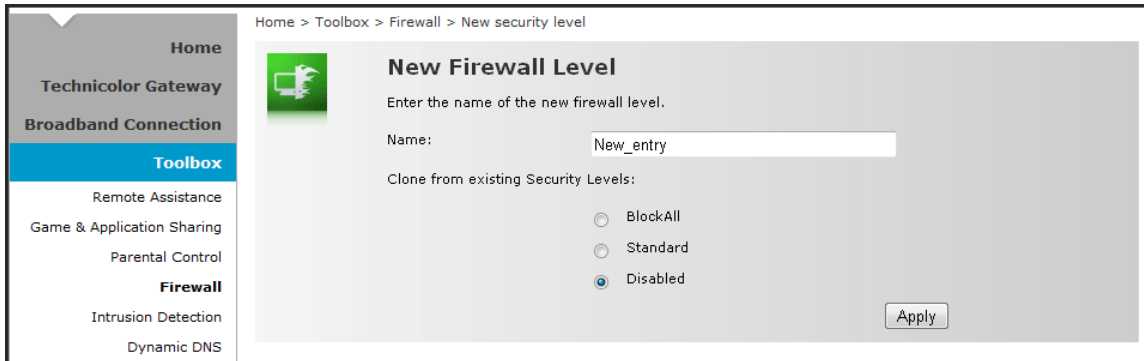

3. Enter the name for the new firewall security level.
4. Select a security level.
5. Click **Apply** to save changes.

7.4.3 Set Filter Rules

After you create a new security level, you can set firewall rules.

1. On the **Firewall** page, click **Configure** on the upper-right corner of the screen.
2. Click **Edit**. The **Firewall Settings** appears.
3. On the **Firewall Settings** table, click **Add**.

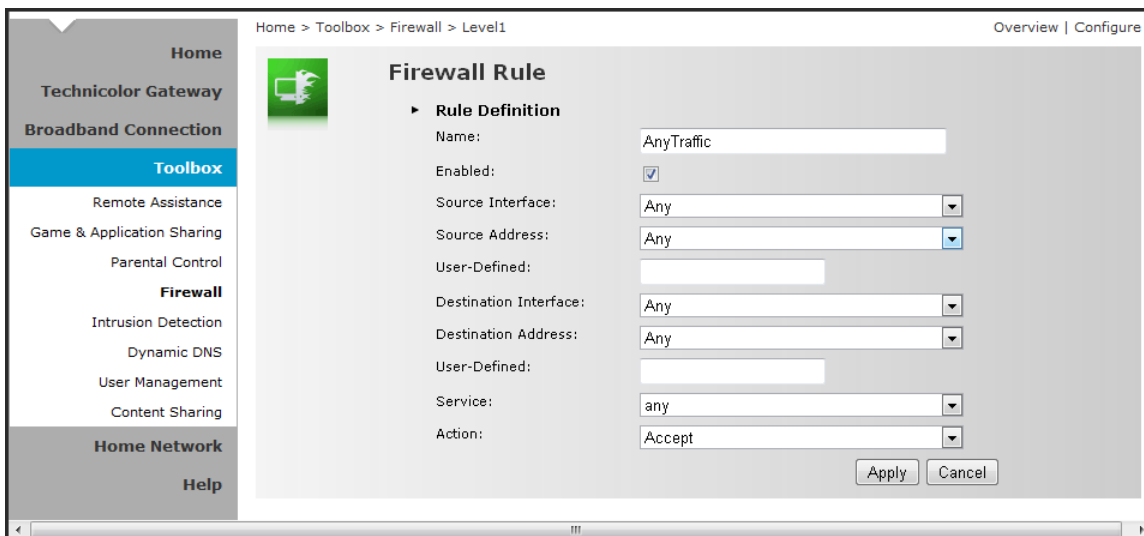

4. Enter the necessary parameters:
 - **Name** — Enter desired firewall rule name
 - **Enabled** — Check this box to enable this firewall rule.
 - **Source Interface** — Select the interface to apply the firewall rule.
 - **Source Address** — Select the firewall source address.
 - **User-Defined** — If the address is not listed in the Source Address box, enter a user-defined address here.
 - **Destination Interface** — Select the destination interface.
 - **Destination address** — Select the destination address.
 - **User-Defined** — If the address is not listed in the Destination Address box, enter a user-defined address here.
 - **Service** — Select a service.
 - **Action** — Select the action to take: **Deny** or **Accept**.
5. Click **Apply** to save changes. The new firewall rule appears on the Firewall Settings table.

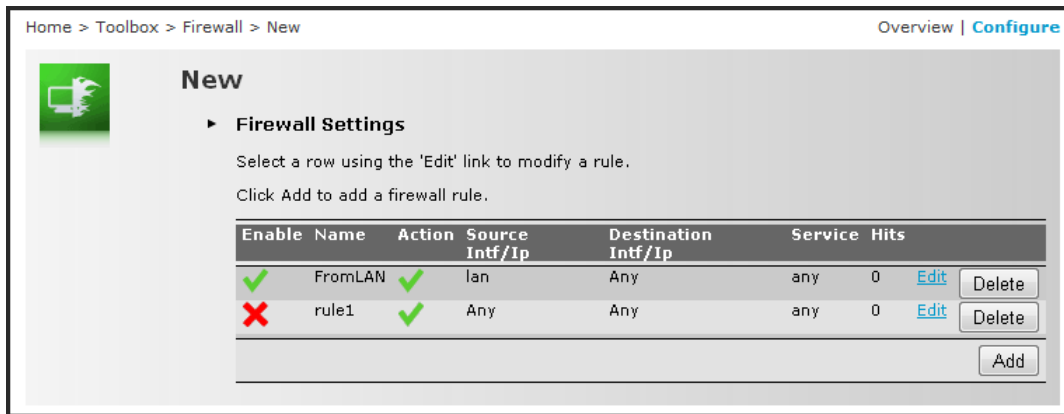

To edit a firewall rule, click **Edit**.

To delete a firewall rule, click **Delete**.

7.5 Intrusion Detection

Your Wireless Gateway protects your network against malicious intrusions. The **Intrusion Detection** page shows you the intrusions that you are protected against. The **Protected Intrusions** table shows the number of times the Wireless Gateway actively protected your network against each intrusions.

To view the **Intrusion Detection** page, on the main menu, click **Toolbox > Intrusion Detection**.

7.6 Dynamic DNS

The Dynamic DNS (DDNS) service allows you to assign a fixed DNS host name to an Internet connection even if it is using a dynamic IP address. As soon as your Wireless Gateway internal connection gets a new IP address, the dynamic DNS service updates the host name entry to the new IP address. The dynamic DNS service relies on servers that link the public IP address to a subscribed DNS host name.

To view the **Dynamic DNS** page, on the main menu, click **Toolbox > Dynamic DNS**.

The screenshot shows the 'Dynamic DNS Service' overview page. The left sidebar contains a navigation menu with categories: Home, Technicolor Gateway, Broadband Connection, **Toolbox** (highlighted), and Home Network. Under 'Toolbox', options include Remote Assistance, Game & Application Sharing, Parental Control, Firewall, Intrusion Detection, **Dynamic DNS**, User Management, and Content Sharing. The main content area has a breadcrumb trail 'Home > Toolbox > Dynamic DNS' and links for 'Overview' and 'Configure'. A red icon with a '@' symbol is next to the title. Below the title is a descriptive paragraph: 'Dynamic DNS can be used to point a fixed host name (e.g. host.a-domain.com) to the public (or WAN) IP address assigned by your Internet Service Provider (typically a dynamic IP address). This allows servers located on your Local Network (configured using Game & Application Sharing) to be accessible using this alias rather than the IP address assigned by your Internet Service Provider.' A 'Configuration' section follows, listing several settings:

Configuration	
Use DynDNS:	No
Internet Service:	-
Username:	-
Password:	-
IP address:	-
Dynamic DNS service:	-
Hosts:	-

In order to use a dynamic DNS service, you must first register and enroll for DNS service with a Dynamic DNS service provider. The DDNS service provider will provide the necessary parameters to complete your Wireless Gateway Dynamic DNS setup.

To configure the Dynamic DNS service of your Wireless Gateway, click **Configure** on the upper-right corner of the screen.

The screenshot shows the 'Dynamic DNS Service' configuration page. The layout is similar to the overview page, but the 'Configure' link is active. The main content area contains a red icon with a '@' symbol and a title 'Dynamic DNS Service'. Below the title is a paragraph: 'In order to use a dynamic DNS service, you must first visit the website of a Dynamic DNS service provider and register. You will receive parameters (username, password, hostname...) that can be used to configure your Technicolor Gateway.' A 'Configuration' section follows, listing several settings:

Configuration	
Enabled:	<input type="checkbox"/>
Interface:	Internet
Username:	<input type="text"/>
Password:	<input type="text"/>
Confirm password:	<input type="text"/>
Service:	www.dyndns.org
Host:	<input type="text"/>

An 'Apply' button is located at the bottom right of the configuration area. Below the configuration area, there is a 'Pick a task...' section with a link: 'Use multiple hosts'.

- **Enabled** — Check this box to enable the DDNS.
- **Interface** — The DDNS interface is the Internet.

- **Username** — Enter the username provided by the DDNS service provider.
- **Password** — Enter the password provided by the DDNS service provider.
- **Confirm Password** — Re-type the password to confirm.
- **Service** — Select the DDNS service provider where your account is registered.
- **Host** — Type the host name.

Click **Apply** to save changes.

To use multiple hosts, click the **Use multiple hosts** shortcut at the bottom of the screen. Then click **Add** to add host name.

7.7 User Management

The **User Management** page allows you to configure the users who can access the Wireless Gateway web configuration utility.

To view the **User Management** page, click **Toolbox > User Management**.

Home > Toolbox > User Management Overview | Configure

User Management

This page provides you with information regarding the users configured on your Technicolor Gateway.

▶ **Local User Data**

The table below shows the configured users who are able to access your Technicolor Gateway. You need to configure user privileges if you want to differentiate between people using your Technicolor Gateway. The current privileges of the user are mentioned in the privileges column.

Username	Privileges	Default User
admin	Administrator	✓
tech	Administrator	
technicolor	Administrator	

Pick a task...

- ▶ [Change my password](#)
- ▶ [Set the default user](#)
- ▶ [Add new user](#)
- ▶ [Switch to another user](#)

7.7.1 Add New User

1. Click the **Add new user** shortcut at the bottom of the screen.
2. On **Name**, type desired user name. This will be the login name and the password of the new user.
3. On **Administrator Privileges**, select the user privilege.
4. Click **Apply** to save changes.

7.7.2 Reset Password

To reset a password, on the **User Management** screen, click on the user account that you want to reset the password. Then click **Reset Password**.

Aside from resetting the password, no other setting can be modified unless by users of higher privileges.

7.7.3 Manage Users

To change the default user, click the **Set the default user** shortcut at the bottom of the screen.

To switch to another user, click the **Switch to another user** shortcut at the bottom of the screen. This brings you back to the login page, then login with the desired user account.

7.8 Content Sharing

The **Content Sharing** page displays the configuration for sharing the content on a storage device connected to your Wireless Gateway.

Before proceeding with content sharing, plug a USB memory stick or an external hard disk into the USB port of your Wireless Gateway. The USB memory stick or external hard disk will be referred to as USB storage device in the succeeding sections.

To view the Content Sharing page, click **Toolbox > Content Sharing**.

The screenshot shows the 'Content Sharing' configuration page. The left sidebar contains navigation options: Home, Technicolor Gateway, Broadband Connection, Toolbox (highlighted), Remote Assistance, Game & Application Sharing, Parental Control, Firewall, Intrusion Detection, Dynamic DNS, User Management, Content Sharing, Home Network, and Help. The main content area shows the breadcrumb 'Home > Toolbox > Content Sharing' and a title 'Content Sharing' with a folder icon. Below the title is a description: 'This page summarizes the configuration for sharing the content on a USB disk connected to the gateway. You can share your files, music, pictures and movies towards your home network and towards the Internet.' The configuration is organized into sections:

- Network File Server (Windows Networking)**: Server Name: samba, Server Description: DSL Gateway, Workgroup: Workgroup, Server Enabled: No.
- UPnP AV Media Server**: Server Enabled: No.
- FTP Server**: Server Address: ftp://192.168.1.254, Server Enabled: Yes.
- List of connected disks**: A table showing a managed partition on Disk 1.

Managed partition			
(Disk 1)			
Partition 1	247 MB	139 MB free	Yes

7.8.1 Share Content Using Network File Server

Your Wireless Gateway supports the Samba function through which you can directly access the data and media files on your storage device with other users on the network. When enabled, the USB storage disk appears on the network folders and is accessible to other devices on the network.

To enable this feature, do the following:

1. On the main menu, click **Toolbox > Content Sharing**.
2. On the **Content Sharing** page, click **Configure** on the upper-right corner of the screen.

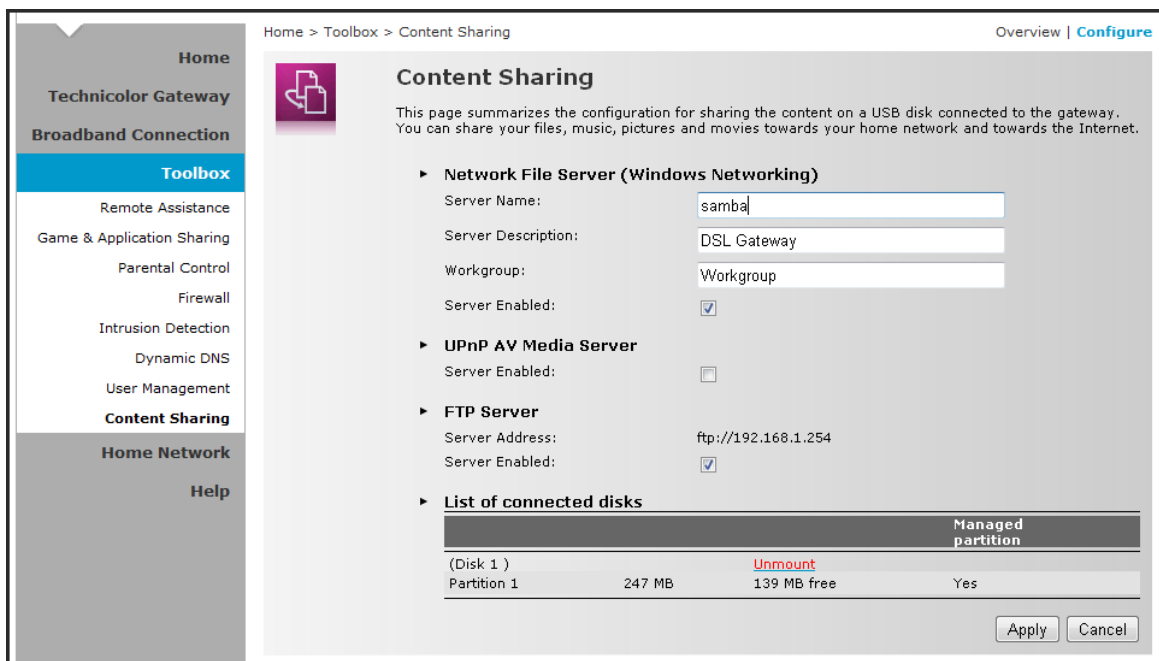

3. If desired, you may modify the **Server Name** and **Server Description**. You will use the server name to access the USB storage device.
4. On the **Network File Server** section, check the **Server Enabled** box.
5. Click **Apply** at the bottom of the screen to save changes.

To Access Shared Files in Windows

1. Open Windows Explorer.
2. Browse for the server name, this is the USB storage device connected to your Wireless Gateway. The USB storage device is listed under Network folders.

7.8.2 Share Media Files Using Media Servers

You can share media files with media devices like IP set-top boxes.

1. On the main menu, click **Toolbox > Content Sharing**.
2. On the **Content Sharing** page, click **Configure** on the upper-right corner of the screen.
3. On the **UPnP AV Media Server** section, check the **Server Enabled** box.
4. Click **Apply** at the bottom of the screen to save changes.

7.8.3 Share Files Using FTP Server

You can share files by FTP. This is useful if you want to access your shared content from the Internet.

1. On the main menu, click **Toolbox > Content Sharing**.
2. On the **Content Sharing** page, click **Configure** on the upper-right corner of the screen.
3. On the **FTP Server** section, check the **Server Enabled** box.
4. Click **Apply** at the bottom of the screen to save changes.

7.8.4 Unmount USB Storage Device

1. On the main menu, click **Toolbox > Content Sharing**.
2. On the **Content Sharing** page, click **Configure** on the upper-right corner of the screen.
3. On the **List of connected disks** table, click **Unmount**.
4. Unplug the USB storage device from your Wireless Gateway.

7.8.5 USB Printer Sharing

You can share a USB printer connected to your Wireless Gateway among network devices.

Before using USB printer sharing, you must configure the printer server first. Do the following:

NOTE:

The following illustrations are from a Windows 7 computer. Similar procedures apply to other Windows OS versions.

1. Connect the USB printer to your Wireless Gateway USB port.
2. Have the printer software ready on your computer.
3. Open **Devices and Printer**, and click **Add a printer**.
4. Configure the new printer.

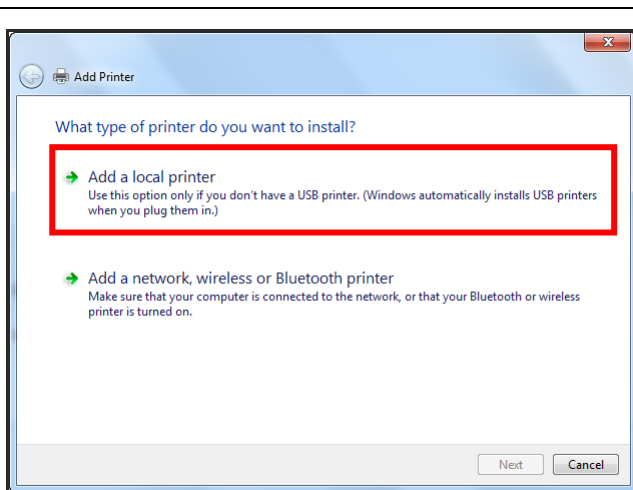

a. Select **Add a local printer**.

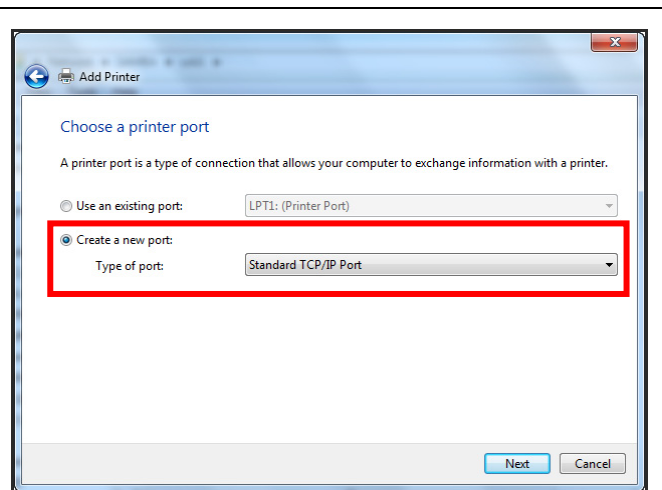

b. Select **Create a new port**, then select **Standard TCP/IP Port**.

c. Click **Next**.

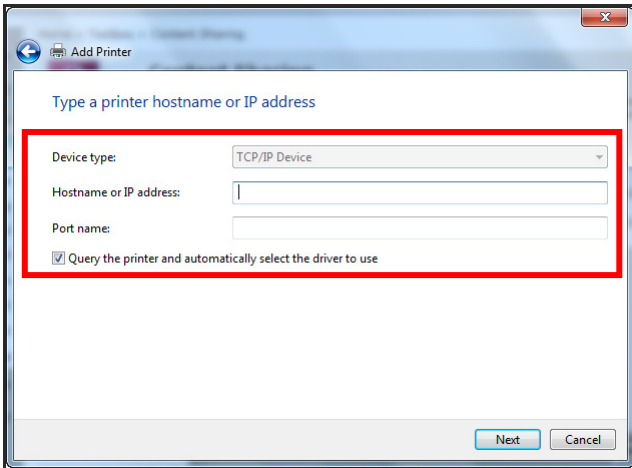

- d. Type the host name or IP address of your Wireless Gateway.
- e. Check **Query the printer and automatically select the driver to use**.

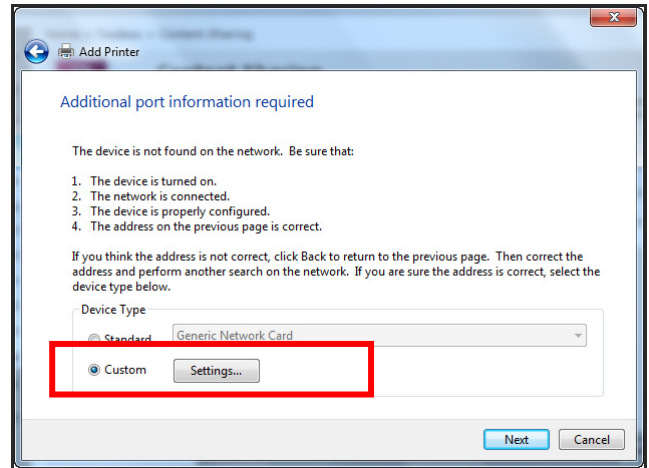

- f. Select **Custom**, then click **Settings**.

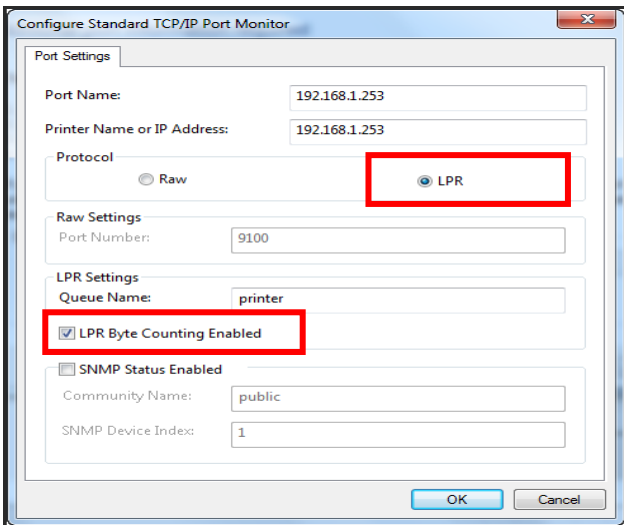

- g. Enter the port name or IP address of your Wireless Gateway.
- h. Select **LPR**.
- i. Select **LPR Byte Counting Enabled**.
- j. Click **OK**.

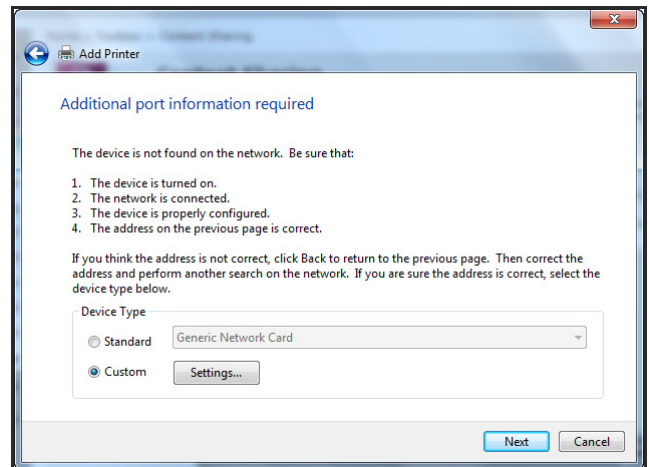

- k. Click **Next** to continue.

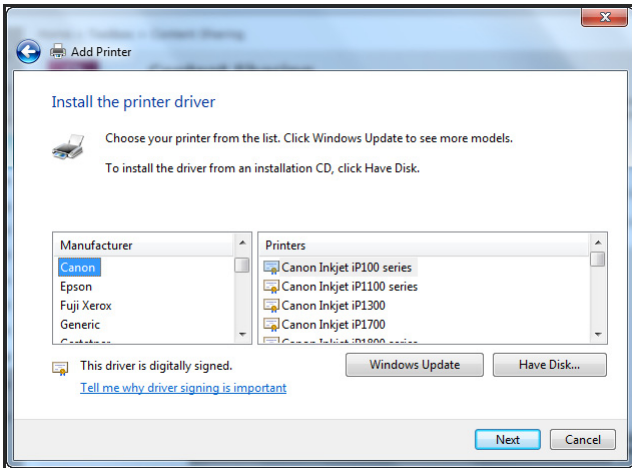

l. If the computer cannot detect the printer driver, select your printer from the list, then click **Next**.

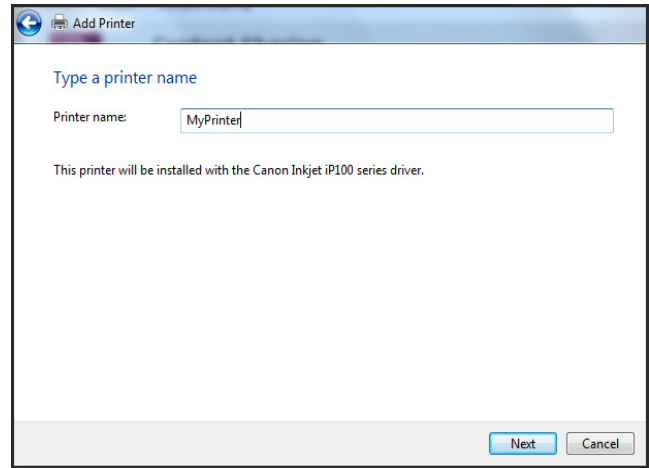

m. Type desired **Printer name**, then click **Next**.

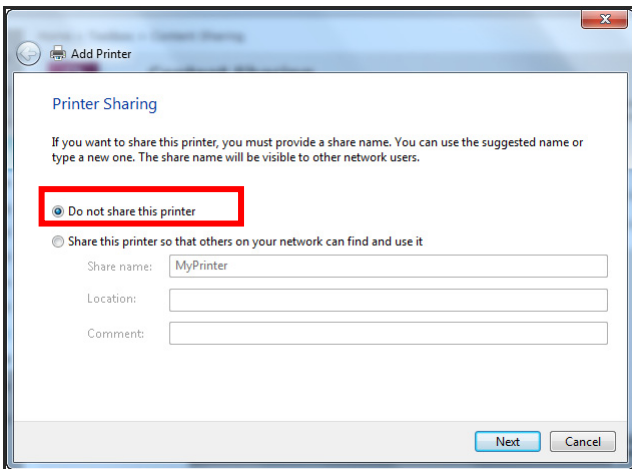

n. Select **Do not share this printer**.
o. Click **Next** to continue.

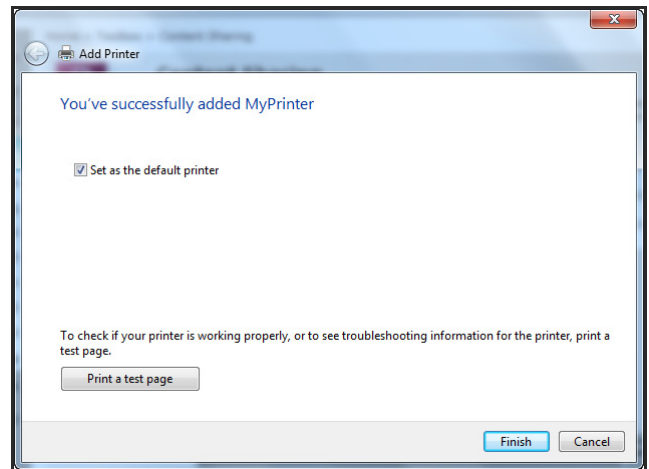

p. Print a test page.
q. Click **Finish** when done.

7.8.6 3G Dongle Sharing

You can share a 3G network when a USB 3G dongle is connected to your Wireless Gateway.

1. Plug the USB 3G dongle to the USB port of your Wireless Gateway.
2. If the 3G dongle is supported, the Wireless Gateway automatically detects the 3G dongle in **Home Network > Interfaces**.
3. Follow the on-screen instructions on how to set up the access point and PIN of the 3G dongle.

Notes on RF Exposure:

To comply with FCC/IC RF Exposure Limits set forth for an uncontrolled environment, the product must be installed and operated with a minimum separation distance (between nearby person(s) and radiating antenna) according to the following scenarios:

1. 20cm minimum when the product is operated alone without co-transmitting with a plug-in 3G USB dongle device.
2. 45cm minimum when the product is operated with a plug-in 3G USB device which has a maximum of 7W ERP output power.
3. For co-transmission scenario which is not covered above, please consult the RF technician or device supplier.

Chapter 8: Home Network

The **Home Network** menu displays the network configuration of your Wireless Gateway, along with interfaces and connected devices. This menu is divided into two sections: **Devices** and **Interfaces**.

To view the **Home Network** page, click **Home Network** on the main menu.

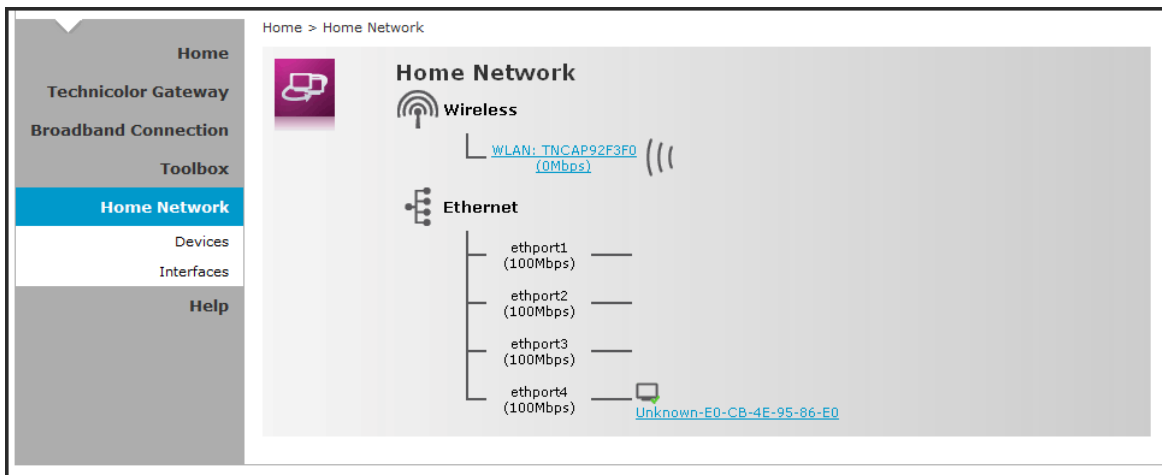

8.1 Devices

This page displays the devices connected on your network via the Wireless Gateway Ethernet ports. You can do the following:

- View the device information, IP address and connection services
- Assign a public IP address to a device

To access the Devices page, click **Home Network > Devices**.



8.1.1 View or Modify Device Information

1. Click the device name. The device information is displayed on screen.
2. To modify the device information, click **Configure** on the upper right corner of the screen.
3. Type desired device name in **New Name**.
4. Select the device type in **Type**.
5. To assign a static IP address, check the **Always use the same IP address box**.
6. Click **Apply** to save changes.

8.1.2 Assign Game or Application to Device

1. Click the device name. The device information is displayed on screen.
2. Click **Configure** on the upper-right corner of the screen.
3. On the **Connection Sharing** section, select the game or application on the table.
4. Click **Add**.

8.1.3 Remove a Shared Game or Application

1. Click the device name. The device information is displayed on screen.
2. Click **Configure** on the upper-right corner of the screen.
3. On the **Connection Sharing** section, click the corresponding **Unassign** button of to remove the shared game or application.

8.1.4 Assign a Public IP Address to Device

The Assign Public IP page allows you to assign the public IP address of your Internet connection to a specific device on your local network.

1. Click **Home Network > Devices**.
2. Click the **Assign the public IP address of a connection to a device** shortcut. The **Assign Public IP** screen appears.

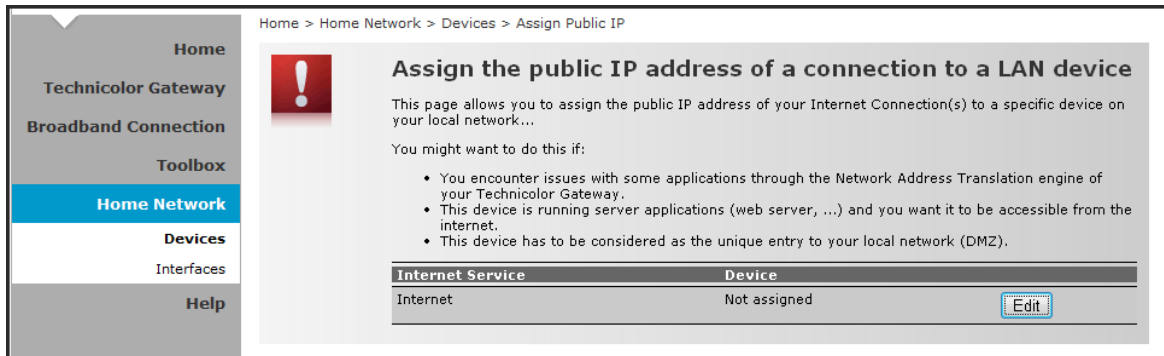

3. Click **Edit**.
4. On **Device**, select the network device that you want to assign the public IP address.
5. Click **Apply**.

Or, to remove the assigned IP address from a network device, click **Unassign**.

8.2 Interfaces

The **Interfaces** page allows you to configure the network device TCP/IP settings such as IP address subnet mask, assign a DHCP server, and configure the wireless network security settings.

To view the **Interfaces** page, click **Home Network > Interfaces**.

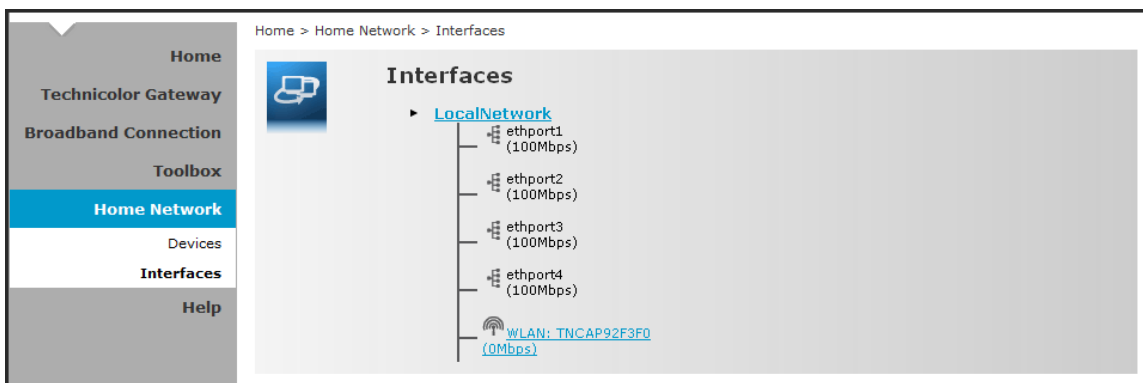

8.2.1 Local Network Interface

Click **Home Network > Interfaces > LocalNetwork** to open the Local Network page.

This page displays the interface information including the TCP/IP configuration, IP Addresses, DHCP pool. To modify the settings, click **Configure** on the upper-right corner of the screen.

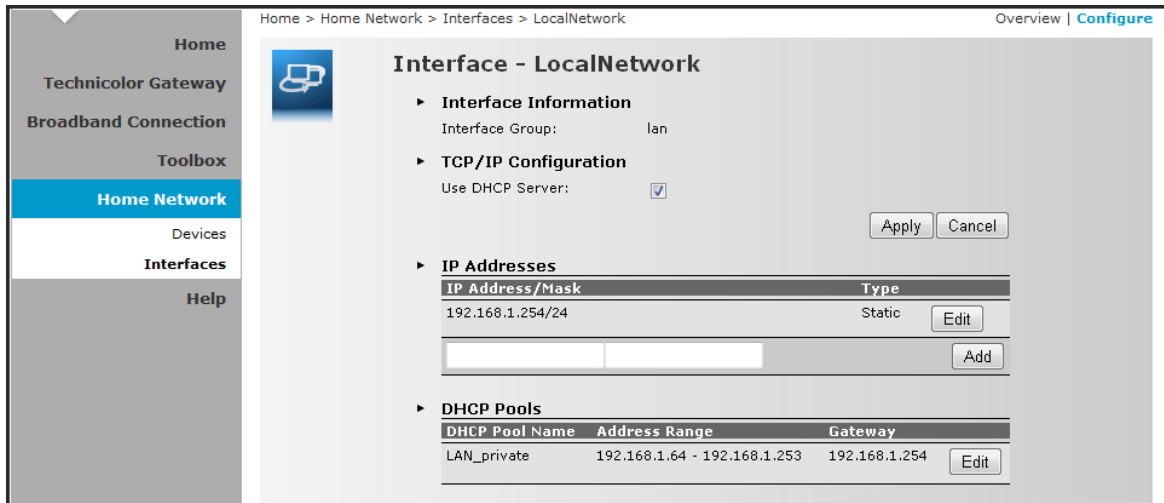

To use a DHCP Server, check the **Use DHCP Server** box, then click **Apply**.

To Add an IP Address

1. On the IP Addresses table, type the IP address you want to add on the first box.
2. Type the subnet mask on the second box.
3. Click **Add**.

To Modify the IP Address

1. On the IP Addresses table, click the corresponding **Edit** button of the IP address you want to modify.
2. Modify the IP address (first box) and the subnet mask (second box).
3. Click **Apply** to save changes.

To Modify the DHCP Pool

1. Click the **Edit** button of the pool you want to modify. The LAN_Private screen appears.

Home > Home Network > Interfaces > LAN_private Configure

DHCP Pool LAN_private

Configure parameters for your DHCP pool.

► **Pool Configuration**

Interface: LocalNetwork

Start Address: 192.168.1.64

End Address: 192.168.1.253

Subnet Mask: 255.255.255.0

Gateway: 192.168.1.254

Primary DNS: 192.168.1.254

Secondary DNS: 0.0.0.0

Lease Time: Infinite

Always give same address to DHCP clients:

Apply Cancel

- **Interface** — Displays the current network interface.
- **Start Address** — Type the starting address of the DHCP pool.
- **End Address** — Type the ending address of the DHCP pool.
- **Subnet Mask** — Type the subnet mask.
- **Gateway** — Type the gateway.
- **Primary DNS** — Type the primary DNS.
- **Secondary DNS** — Type the secondary DNS.
- **Always give same address to DHCP clients** — Check to always give the same address for all DHCP clients. Otherwise, remove the check.

When done, click **Apply**.

8.2.2 Wireless Access Point

Click **Home Network > Interfaces > WLAN** to open the Wireless Access Point page.

This page displays the information of your wireless network. To view the advanced settings, click **Details** on the upper-right corner of the screen.

The screenshot shows the 'Wireless Access Point - TNCAP92F3F0' configuration page in the Overview tab. The left sidebar contains navigation options: Home, Technicolor Gateway, Broadband Connection, Toolbox, Home Network (selected), Devices, Interfaces, and Help. The main content area displays the following configuration details:

Configuration	
Interface Enabled:	Yes
Physical Address:	00:18:E7:92:F3:F0
Network Name (SSID):	TNCAP92F3F0
Interface Type:	802.11b/g/n
Actual Speed [Mbps]:	0
Band:	2.4GHz
Channel Selection:	Auto
Region:	Europe
Channel:	1
WMM:	Disabled

Security	
Broadcast Network Name:	Yes
Allow New Devices:	New stations are allowed (automatically)
Security Mode:	disable

To Configure the Wireless Network

Click **Configure** on the upper-right corner of the screen.

The screenshot shows the 'Wireless Access Point - TNCAP92F3F0' configuration page in the Configure tab. The left sidebar is the same as in the Overview tab. The main content area displays the following configuration details:

Configuration	
Interface Enabled:	<input checked="" type="checkbox"/>
Physical Address:	00:18:E7:92:F3:F0
Network Name (SSID):	<input type="text" value="TNCAP92F3F0"/>
Actual Speed [Mbps]:	0
Band:	2.4GHz
Channel Selection:	<input type="text" value="Automatic"/>
Region:	Europe
Channel:	<input type="text" value="1"/>

Security	
Broadcast Network Name:	<input checked="" type="checkbox"/>
Encryption:	<input checked="" type="radio"/> Disabled <input type="radio"/> Use WEP Encryption <input type="radio"/> Use WPA-PSK Encryption

- **Interface Enabled** — Check to enable the wireless access point.
- **Physical Address** — Displays the MAC address of the wireless device.
- **Network Name (SSID)** — Enter desired wireless network name.
- **Actual Speed** — Displays the network speed
- **Band** — Displays the channel band.
- **Channel Selection** — Select the automatic or manual channel selection.
- **Region** — Displays your current region.
- **Channel** — If **Channel Selection** is set to manual, select the channel from the list.

- **Broadcast Network Name** — Check the box to enable wireless devices to see the SSID of your wireless network.
- **Encryption** — Select an encryption method:
 - **Disabled:** No encryption.
 - **Use WEP Encryption** — To use WEP encryption.
 - **Use WPA-PSK Encryption** — To use a WPA-PSK encryption for more security.

Use WEP Encryption

The screenshot shows a 'Security' dialog box with the following fields and options:

- Broadcast Network Name:**
- Encryption:** Disabled, Use WEP Encryption, Use WPA-PSK Encryption
- WEP Key Length:** 64 bit (dropdown menu)
- WEP Encryption Key:** A25E7CD118 (text input)
- Buttons:** Apply, Cancel

- **WEP Key Length** — Select the key length.
- **WEP Encryption Key** — Type the desired encryption key. Users need to enter this passkey to connect to the wireless network.

Use WPA-PSK Encryption

The screenshot shows a 'Security' dialog box with the following fields and options:

- Broadcast Network Name:**
- Encryption:** Disabled, Use WEP Encryption, Use WPA-PSK Encryption
- WPA-PSK Encryption Key:** 12345678 (text input)
- WPA-PSK Version:** WPA+WPA2 (dropdown menu)
- Buttons:** Apply, Cancel

- **WPA-PSK Encryption Key** — Type the desired passkey. Users need to enter this passkey to connect to the wireless network.
- **WPA-PSK Version** — Select the WPA-PSK version to use.

Appendix

A. Wireless Considerations

Connection Performance

A number of factors affect wireless connections. To ensure high-range and stable connectivity, do the following:

1. Keep the Wireless Gateway and other wireless devices away from obstructions, such as walls or buildings. Each obstruction can reduce the range of a wireless device.
2. Keep the Wireless Gateway and other wireless devices away from devices that produce radio frequency (RF) noise, such as microwave ovens or radios.
3. Keep the Wireless Gateway and other wireless devices away from any device operating on the 2.4GHz frequency, such as cordless phones or remote controls.

Security Checklist

Wireless network signals can be intercepted easily. To prevent unauthorized users from connecting to your wireless network, follow the guidelines below.

1. Change the default wireless network name.
Your device has a default Service Set Identifier (SSID) which is the wireless network name. Change the SSID with a unique name to identify your network. The SSID can be up to 32 characters in length.
2. Change the default password.
Your device has a default password. You have to enter this password to change your network settings. Change the password to prevent unauthorized users from hacking into your network and changing the settings.
3. Enable MAC address filtering.
Your device supports Media Access Control (MAC) address filtering. You can assign a MAC address on each computer that you want to connect to your wireless network. When MAC address filtering is enabled, only the computers with the specified MAC addresses are allowed access.
4. Enable encryption
Your device supports Wired Equivalent Privacy (WEP), and Wi-Fi Protected Access (WAP/WPA2) encryption. To ensure a high level of security, enable the highest security encryption and use strong passphrases, avoid using words that can be found in the dictionary.

B. Regulatory & Safety Information

Wireless LAN, Health and Authorization

Radio frequency electromagnetic energy is emitted from Wireless LAN devices. The energy levels of these emissions however are far much less than the electromagnetic energy emissions from wireless devices like for example mobile phones. Wireless LAN devices are safe for use frequency safety standards and recommendations. The use of Wireless LAN devices may be restricted in some situations or environments for example:

Onboard airplanes, or

In an explosive environment, or

In case the interference risk to other devices or services is perceived or identified as harmful

In case the policy regarding the use of Wireless LAN devices in specific organizations or environments (e.g. airports, hospitals, chemical/oil/gas industrial plants, private buildings etc.) is not clear, please ask for authorization to use these devices prior to operating the equipment.

Disclaimers

Installation and use of this Wireless LAN device must be in strict accordance with the instructions included in the user documentation provided with the product. Any changes or modifications made to this device that are not expressly approved by the manufacturer may void the user's authority to operate the equipment. The Manufacturer is not responsible for any radio or television interference caused by unauthorized modification of this device, of the substitution or attachment. Manufacturer and its authorized resellers or distributors will assume no liability for any damage or violation of government regulations arising from failing to comply with these guidelines.

FCC (Federal Communications Commission) Statement

This equipment has been tested and found to comply with the limits for a Class B digital device, pursuant to Part 15 of the FCC Rules. These limits are designed to provide reasonable protection against harmful interference in a residential installation. This equipment generates, uses and can radiate radio frequency energy and, if not installed and used in accordance with the instructions, may cause harmful interference to radio communications. However, there is no guarantee that interference will not occur in a particular installation. If this equipment does cause harmful interference to radio or television reception, which can be determined by turning the equipment off and on, the user is encouraged to try to correct the interference by one of the following measures:

- Reorient or relocate the receiving antenna.
- Increase the separation between the equipment and receiver.

- Connect the equipment into an outlet on a circuit different from that to which the receiver is connected.
- Consult the dealer or an experienced radio/TV technician for help.

FCC Caution: Any changes or modifications not expressly approved by the party responsible for compliance could void the user's authority to operate this equipment. This device complies with Part 15 of the FCC Rules. Operation is subject to the following two conditions:

1. This device may not cause interference, and
2. This device must accept any interference, including interference that may cause undesired operation of this device.

IMPORTANT NOTE:

FCC Radiation Exposure Statement:

This equipment complies with FCC radiation exposure limits set forth for an uncontrolled environment. This equipment should be installed and operated with minimum distance 20cm between the radiator & your body.

This transmitter must not be co-located or operating in conjunction with any other antenna or transmitter.

The availability of some specific channels and/or operational frequency bands are country dependent and are firmware programmed at the factory to match the intended destination. The firmware setting is not accessible by the end user.

RF Exposure Notice:

To comply with FCC/IC RF Exposure Limits set forth for an uncontrolled environment, the product must be installed and operated with a minimum separation distance (between nearby person(s) and radiating antenna) according to the following scenarios:

1. 20cm minimum when the product is operated alone without co-transmitting with a plug-in 3G USB dongle device.
2. 45cm minimum when the product is operated with a plug-in 3G USB device which has a maximum of 7W ERP output power.
3. For co-transmission scenario which is not covered above, please consult the RF technician or device supplier.



CE statement

Europe – EU Declaration of Conformity

This device complies with the essential requirements of the R&TTE Directive 1999/5/EC. The following test methods have been applied in order to prove presumption of conformity with the essential requirements of the R&TTE Directive 1999/5/EC:

EN60950-1: 2006

Safety of Information Technology Equipment

EN 50385: 2002

Product standard to demonstrate the compliance of radio base stations and fixed terminal stations for wireless telecommunication systems with the basic restrictions or the reference levels related to human exposure to radio frequency electromagnetic fields (110MHz - 40 GHz) - General public

EN 300 328 V1.7.1 (2006-10)

Electromagnetic compatibility and Radio spectrum Matters (ERM); Wideband transmission systems; Data transmission equipment operating in the 2,4 GHz ISM band and using wide band modulation techniques; Harmonized EN covering essential requirements under article 3.2 of the R&TTE Directive

EN 301 489-1 V1.8.1 (2008-04)

Electromagnetic compatibility and Radio Spectrum Matters (ERM); ElectroMagnetic Compatibility (EMC) standard for radio equipment and services; Part 1: Common technical requirements

EN 301 489-17 V2.1.1 (2009-05)

Electromagnetic compatibility and Radio spectrum Matters (ERM); ElectroMagnetic Compatibility (EMC) standard for radio equipment; Part 17: Specific conditions for Broadband Data Transmission Systems.

This device is a 2.4 GHz wideband transmission system (transceiver), intended for use in all EU member states and EFTA countries, except in France and Italy where restrictive use applies.

In Italy the end-user should apply for a license at the national spectrum authorities in order to obtain authorization to use the device for setting up outdoor radio links and/or for supplying public access to telecommunications and/or network services.

This device may not be used for setting up outdoor radio links in France and in some areas the RF output power may be limited to 10 mW EIRP in the frequency range of 2454 – 2483.5 MHz. For detailed information the end-user should contact the national spectrum authority in France.



C. Specifications

IC	<ul style="list-style-type: none"> • Main chip: RTL8672-VK • AFE: RTL8271B-VR • Ethernet: RTL8305N-GR • WiFi: RTL8192CE-GR • DDR1: 32MB • Flash: 8 MB Serial
User Interface	<ul style="list-style-type: none"> • ADSL2+: POTS • 2x2 11n 2.4GHz single band • 4x 10/100 Base-T Ethernet LAN ports • 1 x USB Host
Buttons	<ul style="list-style-type: none"> • 1 x Power ON/OFF button • 1 x WPS button • 1 x Reset to default button
LEDs	<p>Front panel</p> <ul style="list-style-type: none"> • Power LED • Ethernet LED • Wi-Fi LED • 3G or WPS LED • ADSL LED • Internet LED <p>Back panel</p> <ul style="list-style-type: none"> • 4 x Ethernet LEDs
IO Ports	<ul style="list-style-type: none"> • 1 x RJ-11 DSL connector • 4 x RJ-45 Ethernet connector • 1 x DC In jack • 1 x USB port
Antenna	<p>Standard: 2 internal printed antenna</p> <p>Reserved: 2 IPEX connectors for external dipole antenna connection</p>
DC inputs	12VDC 1A
Temperature	<p>Operating: 0°C ~ 40° C</p> <p>Storage: -10°c ~ 70°C</p>
Humidity	Operating: 10% ~ 95%, RH, no condensation
PCB Dimensions	142 x 117 x 1.6 mm