

MULTIBAND P25 AIRBORNE TRANSCEIVER MODEL TDFM-600/6000

Installation and Operating Instructions

**Til Document No.
01RE293
Rev.**

January 23 / 2002

Technisonic Industries Limited

250 Watline Avenue, Mississauga, Ontario L4Z 1P4 Tel:(905)890-2113 Fax:(905)890-5338
3840 East Robinson Road, Suite 214, Amherst, New York 14228 Tel:(716)691-0669

CAUTION

This unit contains static sensitive devices. Wear a grounded wrist strap and/or conductive gloves when handling printed circuit boards.



WARNING: This device complies with Part 15 of the FCC Rules. Operation is subject to the following two conditions: (1) this device may not cause harmful interference and (2) this device must accept any interference received, including interference that may cause undesired operation.



WARNING For compliance with FCC RF Exposure Requirements, the mobile transmitter antenna installation shall comply with the following two conditions:

1. The transmitter antenna gain shall not exceed 3 Bi
2. The transmitter antenna is required to be located outside of a vehicle and kept at a separation distance of 70 cm meters or more between the transmitter antenna of this device and persons during operation.

NOTE: *This equipment has been tested and found to comply with the limits for a Class A digital device, pursuant to Part 15 of the FCC Rules. These limits are designed to provide reasonable protection against harmful interference when the equipment is operated in a commercial environment. This equipment generates, uses, and can radiate radio frequency energy and, if not installed and used in accordance with the instruction manual, may cause harmful interference to radio communications. Operation of this equipment in a residential area is likely to cause harmful interference in which case the user will be required to correct the interference at his own expense.*

Warning:

Changes or modifications not expressly approved by Technisonic Industries could void the user's authority to operate the equipment.

WARRANTY INFORMATION

The Model TDFM-600/6000 Transceiver is under warranty for one year from date of purchase. Failed units caused by defective parts, or workmanship should be returned to:

Technisonic Industries Limited
250 Watline Avenue
Mississauga,
Ontario L4Z 1P4

Technisonic Industries Limited
3840 E. Robinson Road, Suite 214
Amherst,
New York 14228

Tel: (905) 890-2113

Fax: (905) 890-5338

Tel: (716) 691-0669

TABLE OF CONTENTS
Title

Paragraph	Title	Page
SECTION 1	GENERAL DESCRIPTION	
1.1	Introduction	1-1
1.2	Description	1-1
1.3	Technical Summary	1-1
SECTION 2	OPERATING INSTRUCTIONS	
2.1	General	2-1
2.14	Radio Service Software	2-4
SECTION 3	INSTALLATION INSTRUCTIONS	
3.1	General	3-1
3.2	Equipment Packing Log	3-1
3.3	Transceiver Installation	3-1
3.4	Installation Kit - Contents	3-1
3.5	Pin Locations and Connections	3-2
3.6	Wiring Instructions	3-3

LIST OF TABLES

Table No.	Title	Page
3-1	25-pin D Connections	3-2

LIST OF ILLUSTRATIONS

Figure No.	Title	Page
3-1	Outline Drawing	3-1
3-2	Wiring Connections and notes	3-5

SECTION 1

GENERAL DESCRIPTION

1.1 INTRODUCTION

This publication provides operating and installation information on the TDFM-600/6000 airborne transceiver. (The exact model number depends on which and how many RF modules are installed.)

1.2 DESCRIPTION

The TDFM-600/6000 series of transceivers are airborne multiband radios capable of conventional FM, P25, Smartnet and Smartzone trunking systems and any other feature supported by the Motorola XTS-3000 portable radio. The modules are available in VHF, UHFLO, UHFHI and 800 MHz bands. The bands are numbered 1,4,5 and 8 respectively.

TDFM-655	-	Two UHF high band modules
TDFM-688	-	Two 800 MHz modules
TDFM-6148	-	One VHF, UHF low and 800 MHz module
TDFM-6158	-	One VHF, UHF high and 800 MHz module

1.3 TECHNICAL CHARACTERISTICS

<u>Specification</u>	<u>Characteristic</u>
Model Designation:	TDFM-600/6000
Physical Dimensions:	Approx. 8" X 3" X 5.75"
Weight:	3 Lbs (1.2 kg)
Operating Temperature Range:	-45EC to +60EC
Power Requirement:	
Voltage:	28.0 Vdc, ∇ 15%
Current:	165mA minimum 5A maximum
RF Output Power:	1 or 5 Watts
Frequency Range - VHF Module:	136 to 178 MHz
UHF LO Module:	403 to 470 MHz
UHF HI Module:	450 to 512 MHz
800 Module:	806 to 870 MHz
Audio Output Power (including sidetone):	500 mW into 600 ohms
Microphone Inputs:	Carbon or Equivalent
Panel Back Lighting:	28 VDC or 5VAC (specified when ordered)

SECTION 2

OPERATING INSTRUCTIONS

2.1 GENERAL

The TDFM-600/6000 transceiver is designed to operate in the same fashion as the Motorola XTS-3000 portable radio. The display has been rearranged into a 2 line display from 4 and some of the numeric keys also double as function keys. Two or three XTS-3000 RF modules are installed in the unit. The display is showing the activity of one module at a time selected by pressing the desired knob. The knobs have multiple functions including volume, channel, display dimmer. The microphone, key line and headphone audio are separate for each of the two or three bands therefore switching from band to band is performed at an audio panel. This allows for separate and simultaneous operation on each of the bands just like having 2 or 3 separate radios.

2.2 FRONT PANEL

Refer to the diagram below:

2.3 POWER SWITCH

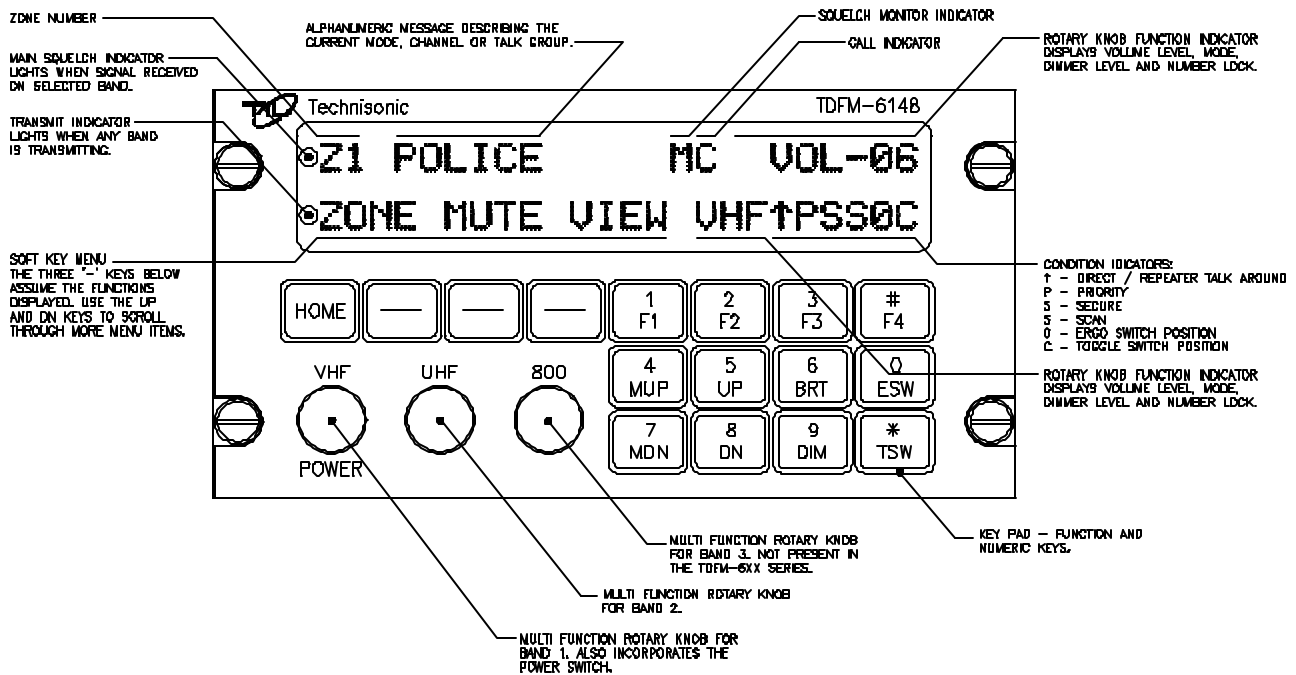

To switch the transceiver on, press the left most knob. The transceiver will immediately power up. The display will show **ATECHNISONIC@** and the software version installed followed by the model number as determined by which RF modules are installed. The display will then show the normal display for band 1. To switch off the transceiver at any time, press and hold the left most knob for 2 seconds until the display shows **AOFF@** then release.

2.4 KNOBS

The transceiver will have two or three knobs depending on how many RF modules are installed. The

knobs are rotary encoders which turn endlessly which means their actual position is not important. Each knob also has a push button incorporated in it so you can press the knob as well as turn it. Pressing a different knob will cause the display and keyboard to switch to the band associated with that knob. The knob will start out as a volume control. Pressing the same knob again will change its function to act as the channel/talkgroup selector depending on how that band is programmed. Pressing the same knob again changes the function of the knob to a display dimmer control. Pressing the knob again causes the key pad function to change from function keys to number keys. The knob in this mode acts as a volume control. Pressing the knob again brings it back to the first mode of volume control. The current function of the knob is shown at the top right of the display. The function of the knobs of the unselected bands are always volume control.

2.5 SOFT KEYS AND HOME

The transceiver has three soft keys which assume the function shown above them on the display. The functions displayed depend on how the module was programmed with the radio service software (RSS). Functions can be different on a channel by channel basis as well. These may include:

ZONE - Pressing this function will prompt you for a new zone number which can be entered directly or scrolled using the UP and DN keys.

MUTE - Selecting this function will prompt you for an on or off entry using the soft keys. Tones refer to the beeps heard when pressing buttons.

VIEW - The view function is used to view lists. Lists can include phone numbers, call lists and or page.

CHAN - Pressing CHAN will prompt you for a new channel number. This can be entered via the key pad or by using the UP and DN buttons. Channel selection can also be programmed as one of the rotary knob functions using the RSS.

PWR - Selecting PWR will allow the power output of the radio to be set to high or low.

PROG - Selecting PROG allows brings you to user programmable features of the radio such as telephone numbers. The ability for the user to program phone numbers, etc can be enabled or disabled by the RSS.

At any time while in one of these functions, you can escape back to the normal mode by pressing the HOME key.

2.6 FUNCTION KEYS

Four function keys at the top of the keypad provide the same actions as the three side buttons and the top button found on the XTS-3000 portable. They are as follows:

F1 - Top side button (purple button) on the XTS-3000.

F2 - Center side button (with one dot) on the XTS-3000.

F3 - Bottom side button (with two dots) on the XTS-3000.

F4 - Top button (orange button) on the XTS-3000.

TDFM-600/6000 Transceiver Recommended Keypad Menu Defaults:

--	--	--	--	--

TDFM-600/6000 ITEM	XTS-3000 Portable ITEM	Conventional Operation (H35)	Smart Net Operation (H37)	Smart Zone Operation (H38)
F1 Key	Top Side Button 1	Monitor	Phone	Phone
F2 Key	Center Side Button 2	Scan	Scan	Scan
F3 Key	Bottom Side Button 3	Talkaround/ Direct	Private Call	Site Display/Search
F4 Key	Orange (Top) Button	Emergency	Emergency	Emergency
MUP and MDN keys	16-Position Rotary Knob	Channel Select	Channel Select	Channel Select
ESW Key	Two-Position Concentric or Ergo Switch	Blank () Low Power (t)	Blank () Low Power (t)	Blank () Low Power (t)
TSW Key	Three-Position Toggle Switch	Blank (A) Scan (B) Blank (C)	Blank (A) Scan (B) Blank (C)	Blank (A) Scan (B) Blank (C)

Note: It is possible to use Motorola's Radio Service Software (RSS or CPS) to alter the default keypad settings of the TDFM-600/6000 series radios. However if custom key settings are chosen it will not be possible for Technisonic to help the Pilot or other Radio User through operational difficulties. These questions will have to be referred to the Radio System Administrator responsible for customising the settings. Technisonic recommends that the default key settings stay in place until all airframe installation and operational issues have been overcome.

The TDFM-600/6000 series Transceivers are programmable by Motorola Radio Service Software. The following settings may be programmed for each Channel in a Conventional Radio:

Tx Frequency	Zone
Tx PL/DPL Code	Channel
Rx Frequency	Name
Rx PL/DPL Code	RX Signal Voice Type
Time-Out Timer	TX Signal Voice Type
Scan List	Network Access Code
Phone	Tx Power
Smart PTT	

The following settings must be programmed for each mode in a Trunked (Smart Net or Smart Zone) Radio:

System Type	TG Strapping
System ID	Zone
Individual ID	Scan List

Coverage Type	Scan Type
Affiliation Type	Interconnect
Control Channel 1	Phone Display Format
Control Channel 2	Private Call
Talkgroup 1	Private Call Type
Talkgroup 2	Private Call Operation

The function keys along with the rest of the key pad, revert to normal number keys during transmit and when NUM LOCK is selected by pressing the rotary knob.

2.7 MUP AND MDN KEYS

These keys provide the same function as the rotary knob does when it is set to MODE. This equates to the 16 position rotary knob on the XTS-3000. When one of these keys is pressed, the function of the rotary knob is automatically set to MODE.

2.8 UP AND DN KEYS

The keys provide the same function as the left and right arrow keys on the XTS-3000. The UP key equates to the right arrow key. These keys are used for a variety of functions but in the normal mode they are used to scroll through the soft key menus.

2.9 BRT AND DIM KEYS

Use these keys to dim or brighten the display. The radio powers up at full brightness for normal use but can be dimmed for night operations.

2.10 ESW KEY

The ESW key provides the function of the concentric or >ergo= switch on the XTS-3000. The switch has two conditions which are represented by >o= and >1=. Pressing the ESW key toggles the condition back and forth. The condition is displayed at the bottom of the display, second character from the right. The ergo switch condition is saved when the unit is turned off. There are separate conditions for each band installed. The ESW key can be programmed with the RSS to a variety of functions such as low power, scan, channel, and secure mode.

2.11 TSW KEY

The TSW key provides the function of the toggle switch on the XTS-3000. The switch has three conditions which are represented by >A=, =B= and >C=. Pressing the TSW key toggles the condition A,B,C,A,B, etc. The condition is displayed at the bottom of the display, last character on the right. The toggle switch condition is saved when the unit is turned off. There are separate conditions for each band installed. The TSW key can be programmed with the RSS to a variety of functions such as low power, scan, channel, and secure mode.

2.12 DISPLAY

The transceiver has a two line, 48 character LED display which gives information about the selected band. On the top line is shown the zone number, channel name and rotary knob function. The bottom line displays the soft key menu, the band selected, and the ESW/TSW condition. Also displayed are letters and symbols indicating scan, direct/repeater talk around, monitor, secure, priority and call. In addition to the character display, there are two LED indicators on the left. The top LED on the indicates a signal is being received on the selected band while the bottom LED indicates that any one or more of the installed bands are transmitting.

2.13 GENERAL OPERATION

Switch on the transceiver as described in 2.3. Select the desired band by pressing the appropriate knob. Select the same band on the audio panel. Press the knob again so that MODE shows up on the top right of the display. Rotate the knob until the desired mode, channel or talk group is selected. Press the knob until VOL is again shown on the display. You can adjust the volume by waiting until a signal is received or by pressing F1 (factory programmed for monitor function) and adjusting the rotary knob. The radio is ready to use. Remember that the band selected by pressing the rotary knobs is what is displayed on the screen but the band selected by the audio panel is band that you are actually transmitting and receiving on. If another band is displayed, the rotary knob for the band you are using is still operating the volume level. To use the DTMF key pad while transmitting, the band you are using must be displayed on the screen.

2.14 RADIO SERVICE SOFTWARE (RSS for DOS or CPS for Windows)

To make any changes to the programming in the radio, RSS software must be used. There is no provision in the radio to allow the user to change frequencies, zones, talk groups, etc. RSS software can be purchased from your local Motorola dealer. Along with the RSS, a Motorola Radio Interface Box (RIB) is required to connect the computer to the TDFM-600/6000. Each band in the TDFM-600/6000 is considered an XTS-3000 portable by the RSS software. To program a band in the transceiver, it must be selected by pressing the appropriate knob before running the RSS. Follow the instructions supplied with the RSS and RIB. The radio cable supplied with the RIB will not connect to the TDFM-600/6000, therefore you will need to fabricate or purchase the cable shown below.

FIGURE 2-2 Programming Cable

SECTION 3

INSTALLATION INSTRUCTIONS

3.1 GENERAL

This section contains information and instructions for the correct installation of the TDFM-600/6000 Transceiver.

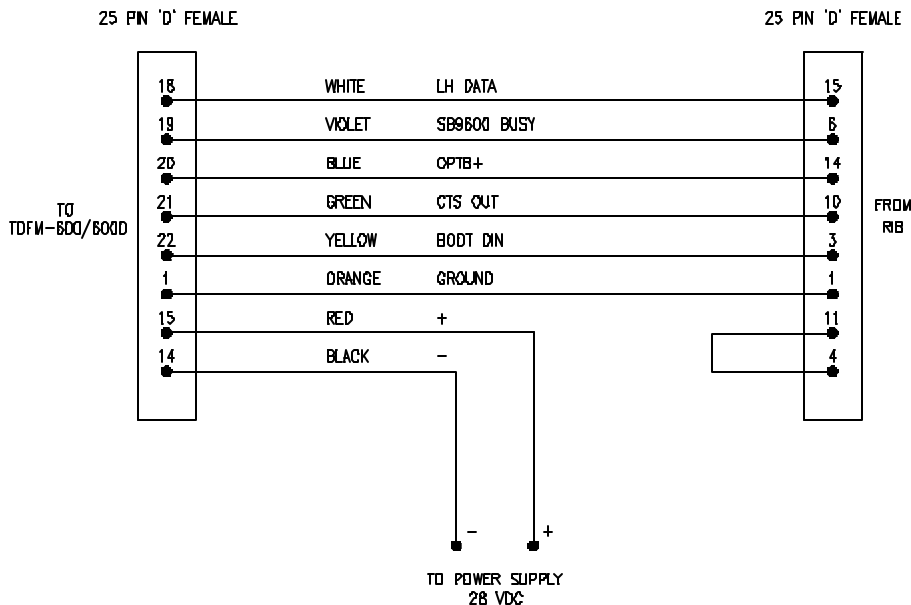

3.2 EQUIPMENT PACKING LOG

Unpack the equipment and check for any damage that may have occurred during transit. Save the original shipping container for returns due to damage or warranty claims. Check that each item on the packing slip has been shipped in the container.

3.3 INSTALLATION

The TDFM-600/6000 Transceiver is designed to be dzus mounted and should be installed in conjunction with an IN-600 installation kit. See figure 3-1 for an outline drawing of the unit with dimensions to facilitate the installation.

3.4 INSTALLATION KIT - CONTENTS

The IN-600 installation kit (P/N 01xxxx-1) consists of:

1. One 25 pin Cannon D mating connector (female) complete with crimp pins and hood.
2. 3 BNC connectors.

3.5 ANTENNA INSTALLATION

The type and number of antennas depends on the model of transceiver being installed. The following is a list of recommended antennas for the various RF modules:

VHF	136 to 176 MHz	Comant part # CI-292
UHFLO	403 to 470 MHz	Comant part # CI-275
UHFHI	450 to 512 MHz	Comant part # CI-275
800	806 to 870 MHz	Comant part # CI-306

The antenna should be mounted on the bottom of the aircraft whenever possible. Consult with instructions provided with the antenna. Connect the RF cables to the back of the transceiver using the BNC connectors provided in the installation kit.

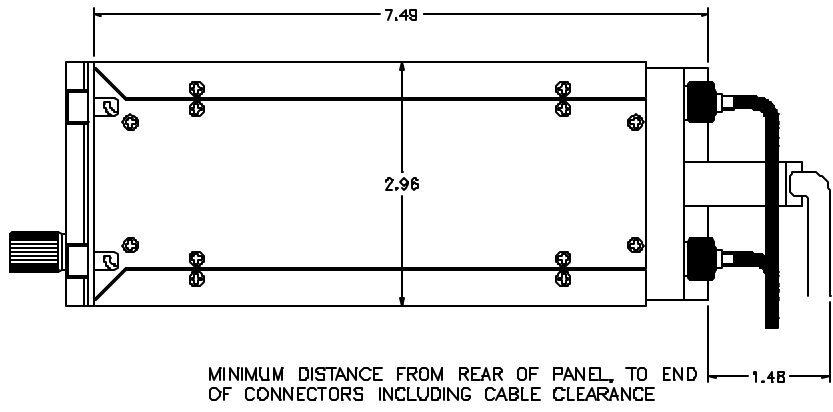
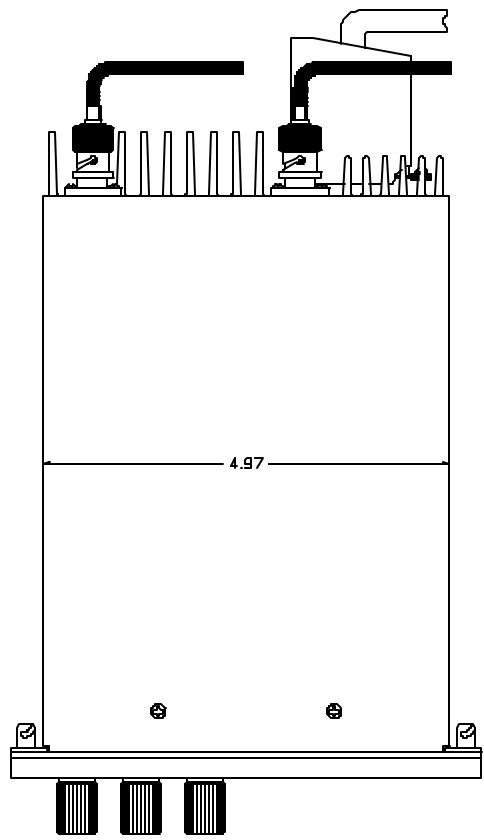

MINIMUM DISTANCE FROM REAR OF PANEL, TO END OF CONNECTORS INCLUDING CABLE CLEARANCE

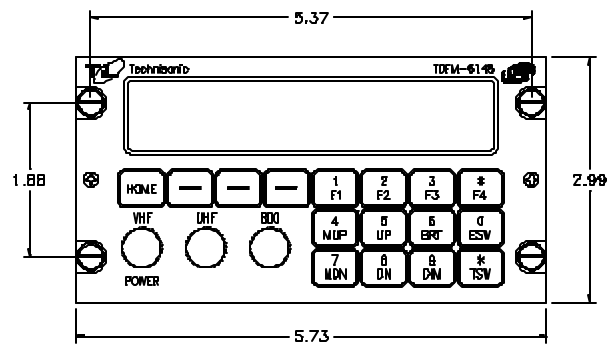

3.6 **FIGURE 3-1 Outline Drawing for Model TDFM-600/6000**
INSTALLATION - PIN LOCATIONS AND CONNECTIONS

>J1' 25 Pin D Connections - Use FEMALE Connector	
Pin #	Description
1	Ground
2	Main Power +28 VDC
3	Mic 1
4	Audio 1
5	PTT 1
6	Mic 2
7	Audio 2
8	PTT 2
9	Mic 3
10	Audio 3
11	PTT 3
12	TX Data
13	RX Data
14	Ground
15	Main Power +28 VDC
16	Memory Up
17	Memory Down
18	LH Data
19	SB9600 Busy
20	OPTB+
21	CTS Out
22	Boot DIN
23	No Connection
24	No Connection

>J1' 25 Pin D Connections - Use FEMALE Connector	
25	Panel Backlighting

TABLE 3-1

3.7 INSTALLATION - WIRING INSTRUCTIONS

Figure 3-2 shows all required connections and recommended wire sizes for the TDFM-600/6000 transceiver.

3.8 MAIN GROUND - PINS 1 AND 14

Both pins should be connected to ground. The main ground is internally connected to the chassis.

3.9 MAIN POWER +28 VDC - PINS 2 AND 15

Both pins should be connected to +28 volts DC +/- 15%.

3.10 MIC 1, 2 AND 3 - PINS 3, 6 AND 9

The microphone input signals shall be connected using shielded wire with the shield connected to ground (pin 1 or 14). It is recommended for best results to leave the other end of the shield floating to prevent ground currents.

3.11 AUDIO 1, 2 AND 3 - PINS 4, 7 AND 10

Audio outputs 1, 2 and 3 are 600 ohms impedance. The output power is 500 mW maximum.

3.12 PTT 1, 2 AND 3 - PINS 5, 8 AND 11

The PTT lines should be floating when in receive and grounded for transmit. The input has a pull up resistor to 5 volts. Connecting an audio panel which wishes to see more may result in no receive audio from the audio panel. Connect a 1N4006 diode in series with the cathode towards the audio panel in this case.

3.13 TX DATA AND RX DATA - PINS 12 AND 13

These are an RS-232 serial port for future use. Leave both pins unconnected.

3.14 MEMORY UP AND MEMORY DOWN - PINS 16 AND 17

These pins can be used to scroll up and down through the zone/channel/mode/talk group selections for the band currently displayed on the screen. The inputs normally floating are grounded to activate. Two push buttons or a center off, SPDT, spring loaded toggle switch are typically used on these inputs.

3.15 LH DATA, SB9600 BUSY, OPTB+, CTS OUT AND BOOT DIN - PINS 18 THROUGH 22

These pins are used for programming or updating the transceiver using Motorola Radio Service Software (RSS) and are generally left unconnected. However, if it is desirable to update the radio without removing it from the aircraft, these lines can be run to a 25 pin D male connector located on the panel where a laptop computer can plug in. Use the same pin numbers so the programming cable described in section 2 can be used (minus the power pins).

3.16 PANEL BACKLIGHTING - PINS 25

Connect to aircraft panel dimming bus. The transceiver comes with either 28 VDC or 5 VAC backlighting circuits.

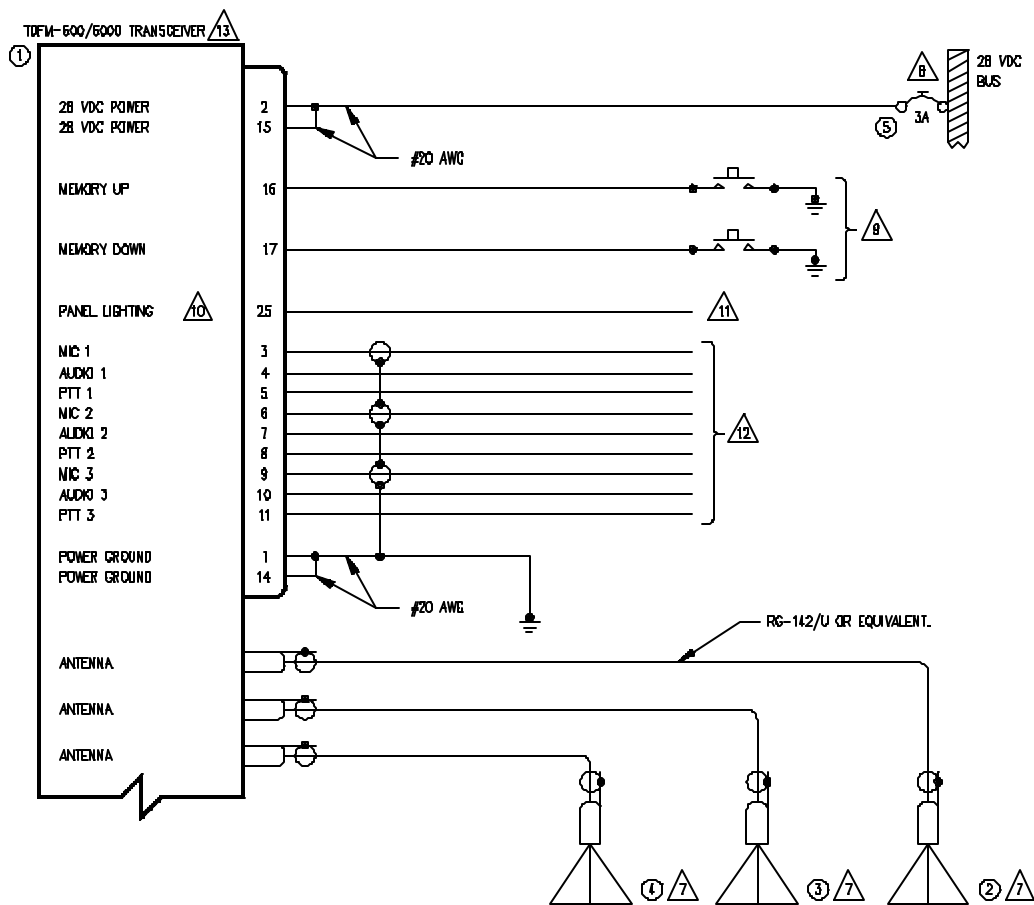

QTY	ITEM	PART NUMBER	DESCRIPTION	SPEC	MATERIAL
1	1	TDFM-600/6000	VHF/FM COMMUNICATIONS TRANSCEIVER.	TECHNISCHE INDUSTRIEN LIMITED	
1	2	CI-292	VHF ANTENNA	COMANT INDUSTRIES	
1	3	CI-275	UHF ANTENNA	COMANT INDUSTRIES	
1	4	CI-306	800 ANTENNA	COMANT INDUSTRIES	
1	5	7274-11-5	CIRCUIT BREAKER, 5 AMPS	KUXON	

NOTES:

- 1) ALL WIRE IAW MIL-W-22759 UNLESS OTHERWISE SPECIFIED.
 - 2) ALL CABLE IAW MIL-C-27500 UNLESS OTHERWISE SPECIFIED.
 - 3) COAXIAL CABLE IAW MIL-C-17 UNLESS OTHERWISE SPECIFIED. DO NOT USE COAX WITH PVC INSULATION.
 - 4) FABRICATION & INSTALLATION OF WIRING HARNESS IAW AC 43.13-1A CHAPTER 11, SECTION 3, PARA 445 TO 462 AND SECTION 7.
 - 5) GROUNDING AND BONDING IAW AC 43.13-1A CHAPTER 11, SECTION 3, PARA 452.
 - 6) ALL SINGLE WIRE TO BE #22 AWG MINIMUM AND ALL SHIELDED WIRE TO BE #24 AWG MINIMUM, UNLESS OTHERWISE SPECIFIED.
- 7) INSTALLATION OF ANTENNA IAW AC 43.13-1A CHAPTER 2, SECTION 3, CHAPTERS 5 & 6, AND AC 43.13-2A CHAPTER 3. IF POSSIBLE, THE ANTENNA SHOULD BE LOCATED A MINIMUM OF 12 FT FROM AIRCRAFT NAVIGATION RECEIVER ANTENNAS AND A MINIMUM OF 4 FEET FROM AIRCRAFT COMMUNICATIONS AND ELT ANTENNAS. BE CAREFUL NOT TO CHOOSE SEPARATIONS THAT CLOSELY APPROXIMATE 1/4 OR 1/2 OR WHOLE NUMBER MULTIPLES OF THE NAVIGATION OR COMMUNICATIONS SYSTEM WAVELENGTH.
- 8) AN EQUIVALENT CIRCUIT BREAKER OR FUSE MAY BE USED.
- 9) THE MEMORY UP/DOWN PUSH BUTTONS ARE OPTIONAL.
- 10) THE TDFM-600/6000 IS AVAILABLE WITH 28V OR 5V PANEL LIGHTING. CHECK THE CONFIGURATION CONTROL LABEL FOR THE CORRECT VOLTAGE.
- 11) CONNECT TO THE APPROPRIATE AIRCRAFT DIMMING BUSS.
- 12) CONNECT TO THE AIRCRAFT AUDIO SYSTEM OR STAND-ALONE HEADSET JACKS.
- 13) INSTALLATION OF TRANSCEIVER IAW AC 43.13-1A CHAPTER 2, SECTION 3 AND AC 43.13-2A, CHAPTER 2, PR 3 1/2 DZUS RAIL OR EQUIVALENT MAY BE USED.
- 14) TEST THE SYSTEM IN ACCORDANCE WITH THE POST-INSTALLATION TEST PROCEDURE IN THE INSTALLATION AND OPERATING INSTRUCTIONS MANUAL.
 - 15) REFER TO THE AIRCRAFT STRUCTURAL REPAIR MANUAL AND THE MAINTENANCE MANUAL FOR INSTRUCTIONS AND INFORMATION PERTINENT TO THIS INSTALLATION.
 - 16) THE USE OF RED DISPLAYS SHOULD BE MINIMIZED OR AVOIDED SO AS NOT TO DETRACT FROM THE ATTENTION GETTING CHARACTERISTICS NEEDED IN WARNING AND CAUTION ANNUNCIATORS. RED SHOULD BE USED TO ANNUNCIATE EMERGENCY CONDITIONS REQUIRING IMMEDIATE RESPONSE BY THE FLIGHT CREW. UNITS WITH RED DISPLAYS SHOULD NOT BE LOCATED IN CLOSE PROXIMITY TO WARNING AND CAUTION ANNUNCIATORS. THE INSTALLATION OF UNITS WITH RED DISPLAYS MUST BE EVALUATED ON A CASE BY CASE BASIS TO ENSURE THAT THE EFFECTIVENESS OF THE WARNING AND CAUTION ANNUNCIATORS IS NOT ADVERSELY AFFECTED.

FIGURE 3-2 Wiring connections and notes for the TDFM-600/6000 Transceiver