



TDFM-7300-3

MULTIBAND P25 AIRBORNE TRANSCEIVER



Installation and Operating Instructions

TiL Document No. 11RE436
Rev. n/c

JULY 2011

Technisonic Industries Limited
240 Traders Boulevard, Mississauga, Ontario L4Z 1W7
Tel: (905) 890-2113 Fax: (905) 890-5338
www.til.ca

Copyright 2011 by Technisonic Industries Limited. All rights reserved.

REVISION HISTORY
[11RE436]

REV	SECTION - PAGE -	DESCRIPTION	DATE	Edited by

NOTES

CAUTION ! STATIC SENSITIVE !



This unit contains static sensitive devices. Wear a grounded wrist strap and/or conductive gloves when handling printed circuit boards.

FCC COMPLIANCE INFORMATION

This device complies with Part 15 of the FCC Rules. Operation is subject to the following two conditions: (1) this device may not cause harmful interference and (2) this device must accept any interference received, including interference that may cause undesired operation.



WARNING: For compliance with FCC RF Exposure Requirements the mobile transmitter antenna installation shall comply with the following two conditions:

1. The transmitter antenna gain shall not exceed 3 dBi.
2. The transmitter antennas shall be located outside of a vehicle and must not be co-located (kept at a separation distance of more than 20cm from each other when installed). Also they must be installed in such a way that they always maintain a separation distance of more than 90cm from any person during operation.

NOTE: This equipment has been tested and found to comply with the limits for a Class A digital device, pursuant to Part 15 of the FCC Rules. These limits are designed to provide reasonable protection against harmful interference when the equipment is operated in a commercial environment. This equipment generates, uses, and can radiate radio frequency energy and, if not installed and used in accordance with the instruction manual, may cause harmful interference to radio communications. Operation of this equipment in a residential area is likely to cause harmful interference, in which case the user will be required to correct the interference at his/her own expense.

Emission Type

Emission Designator – 6K00A3E 25 kHz Ch Spacing and 5K6A3E 8.33 kHz Ch Spacing.
Class of Emission – A3E

WARNING

Changes or modifications not expressly approved by Technisonic Industries could void the user's authority to operate the equipment.

WARRANTY INFORMATION

The Model TDFM-7300-3 Transceiver is under warranty for one year from date of purchase. Failed units caused by defective parts, or workmanship should be returned to:

Technisonic Industries Limited
240 Traders Boulevard
Mississauga, Ontario L4Z 1W7

Tel: (905) 890-2113

Fax: (905) 890-5338

Summary of DO-160C Environmental Testing for Technisonic Model TDFM-7300-3 Transceiver.

CONDITIONS	SECTION	DESCRIPTION OF CONDUCTED TESTS
Temperature and Altitude	4.0	Equipment tested to categories C4 and D1.
Vibration	8.0	Equipment is tested without shock mounts to categories

		B, M and N.
Magnetic Effect	15.0	Equipment is class Z.
Power Input	16.0	Equipment tested to category B.
Voltage Spike	17.0	Equipment tested to category B.
RF Emission	21.0	Equipment tested to category Z.

STC APPROVAL NOTE

Presently, no TSO standard exists for airborne FM transceivers. To make it easier for installation agencies to provide their customers with an approved installation supported by an effective Airworthiness Approval, Technisonic has secured Supplemental Type Certificate (STC) Approvals (both US and Canadian) on its Airborne FM products for many helicopters currently being delivered in the US and Canada as well as a number of single engine fixed wing aircraft. The above referenced DO-160C test data is also on file and available from Technisonic to support approval requirements in airframes for which Technisonic does not possess an STC.

Approved aircraft types are listed in the attachments to the formal STC documents. These STCs are the exclusive property of Technisonic and require the written authority of Technisonic for their use. To assist Factory Authorized Technisonic Dealers in the certification process, we have placed copies of our Canadian and US STCs on our web site along with a letter of authorization for their use. These documents may be downloaded and used as support for the technical submission to FAA or Transport Canada. Only authorized factory dealers/installers are permitted to download and make use of these documents on behalf of their customers (end users) in support of regulatory agency approval. Please refer to the Technisonic web site www.til.ca for the latest issue of available STCs and letter of authorization for use.

COPYRIGHT NOTICE

This document contains designs and other information which are the property of Technisonic Industries Ltd. Except for rights expressly granted by contract to the Canadian Government, or to the United States Government, this document may not, in whole or in part, be duplicated or disclosed or used for manufacture of the part disclosed herein, without the prior permission of Technisonic Industries Ltd.

WARNING AND DISCLAIMER

This manual is designed to provide information about the TDFM-7300-3. Every effort has been made to make this manual as complete and accurate as possible.

TRADEMARK NOTICES

TDFM-7300-3 Transceivers contain two-way radio protocols licensed from Motorola, Inc.
 © 1997, 1998 Motorola, Inc.

TECHNISONIC INDUSTRIES LIMITED

www.til.ca

TABLE OF CONTENTS

SECTION 1 GENERAL DESCRIPTION

1.1	INTRODUCTION	1-1
1.2	DESCRIPTION	1-1
1.3	MODEL VARIATION	1-1
1.4	TECHNICAL CHARACTERISTICS	1-4

SECTION 2 OPERATING INSTRUCTIONS

2.1	GENERAL	2-1
2.2	FRONT PANEL	2-1
2.3	POWER SWITCH	2-2
2.4	KNOB	2-2
2.5	SOFT KEYS AND HOME	2-2
2.6	BAND KEY	2-3
2.7	FUNC KEY	2-3
2.8	F1 to F4 KEYS	2-3
2.9	MUP(4) AND MDN(7) KEYS (Memory Up and Down Keys)	2-5
2.10	UP(5) AND DOWN(8) KEYS	2-5
2.11	BRT(6) AND DIM(9) KEYS	2-5
2.12	ESW(0) KEY (Ergo Switch Key)	2-6
2.13	TSW(*) KEY (Toggle Switch Key)	2-6
2.14	DISPLAY	2-6
2.15	GENERAL OPERATION	2-6
2.16	CUSTOMER PROGRAMMING SOFTWARE (CPS)	2-7
2.17	CONFIGURATION MENU	2-10
2.18	KEYLOADING MODE	2-11
2.19	FRONT PANEL PROGRAMMING (FPP) MODE (Bands 1 – 4)	2-12
2.20	FLASH UPGRADE MODE	2-14
2.21	VHF LOW BAND (BAND 5) OPERATION – Analog Module Variances	2-15

SECTION 3 INSTALLATION INSTRUCTIONS

3.1	GENERAL	3-1
3.2	EQUIPMENT PACKING LOG	3-1
3.3	TRANSCEIVER INSTALLATION	3-1
3.4	INSTALLATION KIT - CONTENTS	3-1
3.5	ANTENNA INSTALLATION	3-1
3.6	PIN LOCATIONS AND CONNECTIONS	3-3
3.7	INSTALLATION (WIRING INSTRUCTIONS)	3-4
3.8	MAIN GROUND	3-4
3.9	MAIN POWER	3-4
3.10	MIC 1, 2, 3, 4, AND 5	3-4
3.11	AUDIO 1, 2, 3, 4, 5 AND COMBINED	3-4
3.12	PTT 1, 2, 3, 4, 5 AND COMBINED	3-5
3.13	RX DATA AND TX DATA	3-5
3.14	CHANNEL UP / DOWN	3-5
3.15	LH DATA, SB9600 BUSY, OPTB+, CTS OUT, BOOT DIN, RTSBIN and RS232DIN	3-5
3.16	PANEL BACKLIGHTING	3-5
3.17	ANTENNA TUNER CONTROL LINES	3-5
3.18	POWER JUMPER	3-5
3.19	POST INSTALLATION EMI TEST	3-9

WARRANTY	
----------------	--

TECHNISONIC INDUSTRIES LIMITED

www.til.ca

LIST OF FIGURES

FIGURE	TITLE	PAGE
2.1	Front Panel Controls – TDFM-7300-3 Series Transceivers	2-1
2.2	PC 7000(II) Programming cable for TYPE II radios P/N 047365-1	2-8
2.3	Encryption Keyload cable for TYPE II radios P/N 037348-1	2-8
2.4	PC 6000(II) Programming cable for TYPE II radios P/N 047366-1	2-9
2.5	USB to Serial Adaptor for Computers without Serial Ports	2-10
3.1	Outline Drawing	3-2
3.2a	Wiring Connections	3-6
3.2b	Wiring Connections Notes	3-7

LIST OF TABLES

TABLE	TITLE	PAGE
2.1	TDFM 7300-3 Series PL/MOT Codes	2-13
2.2	TDFM 7300-3 Series DPL Codes (All Bands)	2-13
2.3	TDFM 7300-3 Analog Band CTCSS/PL Codes	2-14
3.1	Wire connections on a 25-Pin FEMALE D-Connector	3-3
3.2	Wire connections on a 9-Pin FEMALE D-Connector	3-3
3.3	Wire connections on a 15-Pin [high-density] FEMALE D-Connector	3-4

SECTION 1 - GENERAL DESCRIPTION

1.1 INTRODUCTION

This publication provides operating and installation information on the TDFM-7300-3 airborne transceiver. The exact configuration depends on which and how many RF modules are installed.

1.2 DESCRIPTION

The TDFM-7300-3 transceiver is an airborne multi-band radio capable of operation in conventional analog and P25 digital FM systems, SmartNet/SMART ZONE trunking systems and P25 9600 trunking systems. Type II RF modules are available in VHF, UHF LO, UHF HI and 700/800 MHz bands.

These optional additional features include P25 9600 Baud trunking that may be combined with AES and/or DES-OFB encryption with OTAR in any of the available modules.

Bands 1 through 4 on the TDFM-7300-3 are not normally frequency agile. In order to have the ability to change the frequencies at the front panel, the FPP (front panel programming) option must be ordered. FPP is only available on the VHF and UHF modules. The FPP option precludes trunking and limits available channels to 240 (15 zones/16 channels) on that module instead of 1000 channels. Please note that all 240 memories must be filled if FPP is ordered.

The TDFM-7300-3 has provisions for four of the above RF modules as well as one analog only module. This additional module is fully frequency programmable from the front panel and covers the aviation band 117.975 to 138 MHz AM.

1.3 MODEL VARIATION

Irrespective of digital module type the bands are numbered 1, 4, 5 and 8 for VHF, UHF low, UHF Hi and 800/700 respectively. The transceivers part number indicates whether type I (-1, -2) or type II (-3, -4) modules are installed along with which type of modules are installed. The front panel LED display will also indicate which type of modules the transceiver contains.

TECHNISONIC INDUSTRIES LIMITED

www.til.ca

The following part numbers represent typical TDFM-7300-3 model variations:

3-band TDFM-7300-3 Variations

P/N 061245-1-73U188 One VHF and two 800 MHz, type I modules with Green display.

P/N 061245-3-73U148 One VHF, UHF low and 800/700, type II modules with Green display.

4-band TDFM-7300-3 Variations

P/N 061245-2-73U1558 One VHF, two UHF hi and one 800 MHz, type I modules with Red display

P/N 061245-1-73U1148 Two VHF, one UHF lo and 800/700, type II modules with Green display.

SmartNet and SMART ZONE are trademarks of Motorola, Inc.

TDFM-7300-3 Model Variations with type I Modules (-1,-2)

4-Band TDFM-7300-3 Model Variations (-73YXXX)

TDFM-7300-2, P/N 061245-1-73YXXX/P73ZZZ GREEN display.

TDFM-7300-2, P/N 061245-2-73YXXX/P73ZZZ RED display.

TDFM-7300NV, P/N 061245-1-73YXXXNV/P73ZZZ GREEN NV display.

5-Band TDFM-7300-3 Model Variations (-73YXXXX)

TDFM-7300-2, P/N 061245-1-73YXXXX/P73ZZZ GREEN display.

TDFM-7300-2, P/N 061245-2-73YXXXX/P73ZZZ RED display.

TDFM-7300-2NV, P/N 061245-1-73YXXXXNV/P73ZZZ GREEN NV display.

Y is an analog module represented by:

U for UHF (403-512 MHz) module

X is a type I digital module represented by:

1 for VHF (138-174MHz) module

4 for UHF Lo (403-470MHz) module contained in the modules. The Technisonic

5 for UHF Hi (450-512MHz) module sales department assigns project numbers

8 for 800 MHz (806-870)

P73ZZZ represents a 4 or 5-digit project number

that identifies specific options that are

based on customer requirements.

Digital module numbers may be specified in any order required. The analog module is always placed on line 5 of the display. If only 3 digital modules are ordered line 4 of the display will be blank.

TECHNISONIC INDUSTRIES LIMITED

www.til.ca

TDFM-7300-3 Model Variations with type II Modules (-3,-4)

4-Band TDFM-7300-3 Model Variations

TDFM-7300-2, P/N 061245-3-73YXXX/P73ZZZ	GREEN display.
TDFM-7300-2, P/N 061245-4-73YXXX/P73ZZZ	RED display.
TDFM-7300-2NV, P/N 061245-3-73YXXXNV/P73ZZZ	GREEN NV display.

5-Band TDFM-7300-3 Model Variations (-73YXXXX)

TDFM-7300-2, P/N 061245-3-7YXXXX/P73ZZZ	GREEN display.
TDFM-7300-2, P/N 061245-4-7YXXXX/P73ZZZ	RED display.
TDFM-7300-2NV, P/N 061245-3-7YXXXXNV/P73ZZZ	GREEN NV display.

Y is a UHF analog module.

X is type II digital module represented by:

- 1 for VHF (138-174MHz) module
- 4 for UHF Lo (380-470MHz) module
- 5 for UHF Hi (450-520 MHz) module
- 8 for 700/800 MHz (764-870)

P73ZZZ represents a 4 or 5 digit project number that identifies specific options that are contained in the modules. P7301 and up project numbers are used in transceivers with type I or type II modules.

Digital module numbers may be specified in any order required. The analog module is always placed on line 5 of the display. If only 3 digital modules are ordered line 4 of the display will be blank. Hybrid units that contain a mix of both type I and type II modules will have 061245-3 or -4 part numbers. At this time only the VHF Lo analog module is available. Contact Technisonic for availability of other analog modules.

All model variations are capable of supporting both 28 Volt DC and 5 Volt AC back lighting. The units are shipped set to operate on 28 Volt back lighting. Equipment can be set to operate on 5V back lighting by using the software based configuration menu. See Section 2.18 configuration menu.

TECHNISONIC INDUSTRIES LIMITED

www.til.ca

1.4 TECHNICAL CHARACTERISTICS

Specification	Characteristic
Model Designation:	TDFM-7300-3
Physical Dimensions:	Approx. (L) 8.0" x (W) 5.75" x (H) 4.5"
Weight:	Approximately 6.0 Lbs (2.7 Kg)
Operating Temperature Range:	-30°C to +60°C
Power Requirement:	
Voltage:	28.0 VDC ± 15%
Current:	500 mA minimum / 5A maximum
Audio Output Power (including sidetone):	600 mW into 600 Ω
Microphone Inputs:	Carbon or Equivalent
Panel Back Lighting:	
Voltage:	28 or 5 volts AC/DC (selectable)
Current:	3 mA max

Type I Modules

Specification	Characteristic		
RF Output Power:	1 or 5 Watts (VHF) 1 or 4 Watts (UHF) 1 or 3 Watts (800)		
Frequency Range			
VHF Module:	136 to 174 MHz		
UHF LO Module:	403 to 470 MHz		
UHF HI Module:	450 to 512 MHz		
800 Module:	806 to 870 MHz		
No. of channels per band:	255 pre-programmable channels		
Transmitter section	VHF	UHF	800
FM Hum and noise in dB (wideband):	-48	-45	-45
Frequency Stability in ppm:	±2.0	±2.0	±1.5
Audio Distortion (at 1000Hz):	<2%	<2%	<2%
Modulation Limiting:	Wide band	±5kHz	
	Narrow band	±2.5kHz	
Receiver section	VHF	UHF	800
<i>Sensitivity</i> in uV:			
*Digital 1% BER (12.5kHz)	0.35	0.35	0.45
*Digital 5% BER (12.5kHz)	0.25	0.25	0.25
**Analog with 12dB SINAD	0.25	0.25	0.25
<i>Selectivity</i> in dB:			
25 kHz Channel	-78	-78	-75
12.5 kHz Channel	-67	-68	-63
Intermodulation (dB) * **	-78	-77	-74

TECHNISONIC INDUSTRIES LIMITED

www.til.ca

Type II Modules

Specification	Characteristic		
RF Output Power:	1 or 6 Watts (VHF) 1 or 5 Watts (UHF) 1 or 3 Watts (800)		
Frequency Range			
VHF Module:	136 to 174 MHz		
UHF LO Module:	380 to 470 MHz		
UHF HI Module:	450 to 520 MHz		
700 / 800 Module:	764 to 870 MHz		
No. of channels per band:	1000 pre-programmable channels 240 channels (15 zones of 16 channels) for modules with Front Panel Programming.		
Transmitter section	VHF	UHF	800
FM Hum and noise in dB (wideband):	-48	-45	-45
Frequency Stability in ppm:	±2.0	±2.0	±1.5
Audio Distortion:	1%	1.5%	1.5%
Modulation Limiting:	Wide band	±5kHz	
	Narrow band	±2.5kHz	
Receiver section	VHF	UHF	800
<i>Sensitivity</i> in μ V:			
*Digital 1% BER (12.5kHz)	0.25	0.25	0.40
*Digital 5% BER (12.5kHz)	0.25	0.25	0.25
**Analog with 12dB SINAD	0.25	0.25	0.25
<i>Selectivity</i> in dB:			
25 kHz Channel	-80	-78	-72
12.5 kHz Channel	-63	-63	-63
Intermodulation * **	-78	-77	-75

*Measured in digital mode per TIA / EIA IS 102.CAAA under nominal conditions.

** Measured in analog mode per TIA / EIA 603 under nominal conditions.

ANALOG MODULE SPECIFICATIONS

GENERAL

Frequency Ranges: VHF AM analog	117.975 – 138.000 MHz
Operating Mode:	AM
Channel Spacing:	25 kHz (8.33 kHz)
Frequency Selection: via front panel	200 memories per band programmed with: a) Tx Frequency/Rx Frequency b) 9-character alphanumeric title
DTMF encoder:	*All standard DTMF tones

VHF AM RECEIVER

Sensitivity at 12 dB SINAD	Better than 2.0 μ V
Adjacent Channel Selectivity	-70 dB (25 kHz)
Spurious Attenuation	-70 dB
Third Order Intermodulation	-70 dB
Image Attenuation	-60 dB
Hum and Noise	Better than 40 dB
Audio Distortion	less than 5%
Antenna Conducted Emission	less than -70 dBm

TECHNISONIC INDUSTRIES LIMITED

www.til.ca

VHF AM TRANSMITTER

RF Power Output	5 watts (2.5 watts carrier)
Output Impedance	50 ohms
Maximum Modulation (max)	95%
Maximum Modulation (min)	75%
Spurious Attenuation	-60 dB below carrier level
Frequency Stability	± 2.5 ppm
Harmonic Attenuation	-60 dB below carrier level
Signal to Noise Ratio	-35 dB
Audio Input	50 mV at 2.5 kHz into 200 Ω input circuit for 30% modulation (adjustable)
Audio Distortion	Less than 5%

Page left intentionally blank

SECTION 2 – OPERATING INSTRUCTIONS

2.1 GENERAL

A 6-line display and a keypad and a rotary knob provide the operator control of up to 5 RF modules installed in the unit. The display is showing the activity of all 5 modules (bands) as well as the menu of the active band, selected by pressing the BAND key. The knob has multiple functions including volume, and channel. The microphone, key line and headphone audio can be wired separately for each of the 5 bands therefore switching from band to band is performed at an audio panel such as the Technisonic A71X series. This allows for separate and simultaneous operation on each of the bands just like having 5 separate radios. The transceiver can also be connected so that all bands are available on the combined output. In this configuration, the BAND key on the transceiver must perform switching between bands. It is possible to connect the transceiver such that both methods are used.

2.2 FRONT PANEL

Refer to the diagrams below:

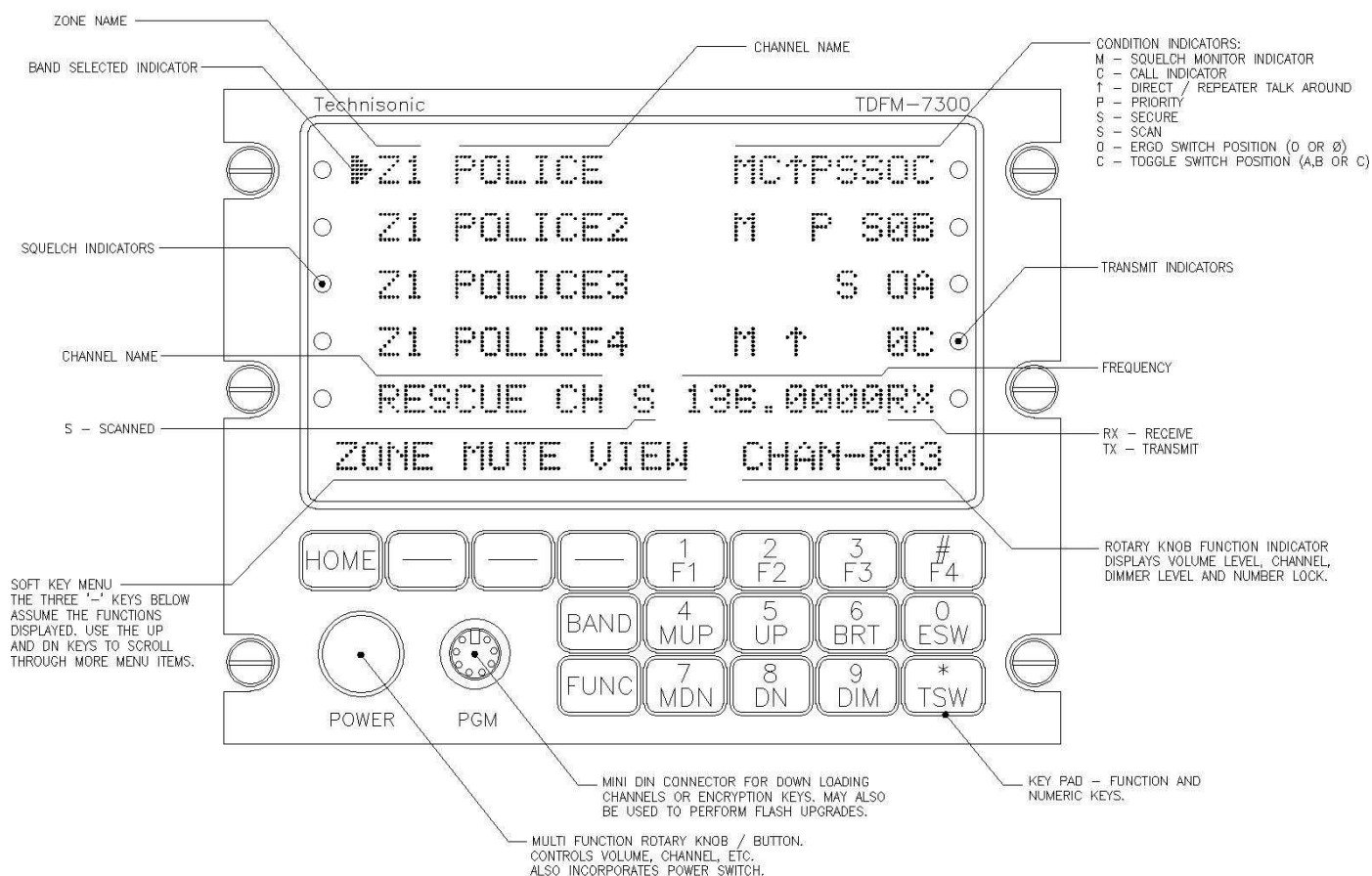

FIGURE 2-1 Front Panel Controls – TDFM-7300-3 Transceiver

2.3 POWER SWITCH

To switch the transceiver on, press and hold the knob until the radio powers up. The display will show TECHNISONIC and the software version installed followed by the model number along with which RF modules are installed. The display will then show the normal display. To switch off the transceiver at any time, press and hold the knob for 2 seconds until the display shows OFF then release. If it is desired that the radio powers up with the radio master in the aircraft, a power jumper may be installed (see installation instructions) such that the radio is always on. The battery master must be used to turn the radio off with this jumper installed.

2.4 KNOBS

The knob is a rotary encoder, which turns endlessly, meaning its actual position is not important. The knob also has a push button incorporated in it so you can press the knob as well as turn it. The knob will start out as a volume control. Pressing the knob again will change its function to act as the channel selector. Pressing the knob again causes the keypad function to change from function keys to number keys. The knob in this mode acts as a volume control. Another knob press will bring you to the recall mode. In the recall mode, typing in the channel number will bring you quickly to that channel without scrolling through channels in between. Pressing the knob again brings it back to the volume control mode. The current function of the knob is shown at the bottom right of the display.

2.5 SOFT KEYS AND HOME

The transceiver has three soft keys, which assume the function shown on the menu above them on the display. The functions displayed depend on how the module was programmed with the customer programming software (CPS)[™]. These menu items can be different on a channel by channel basis. Typical menu items may include:

- ZONE** - Pressing this function will prompt you for a new zone number which can be entered directly (if the keypad is in numlock mode) or scrolled using the UP(5) and DN(8) keys.
- MUTE** - Selecting this function will prompt you for an on or off entry using the soft keys to mute the tones. Tones refer to the beeps heard when pressing buttons.
- PWR** - Selecting PWR will allow the power output of the radio to be set to high or low.
- PROG** - Selecting PROG brings you to user programmable features of the radio such as telephone numbers or scan lists. The ability for the user to program phone numbers, scan lists, etc can be enabled or disabled by the CPS[™].
- VIEW** - The view function is used to view lists. Lists can include scan lists, phone numbers, call lists and or paging.
- FPP** - Front Panel Programming mode allows you to program at the front panel without the customer programming software. This option is available on VHF and UHF type II modules and is always present on band 5 (analog VHF low band module).

At any time while in one of these functions, you can escape back to the normal mode by pressing the HOME key. When programming the modules with the CPS[™], it is suggested not to double up functions. For example, programming a soft key to CHAN would be redundant since there is already a channel function using the knobs. Using the CHAN soft key would also not update the channel number on the display, causing some confusion.

TECHNISONIC INDUSTRIES LIMITED

www.til.ca

2.6 BAND KEY

Pressing the BAND key will select the next band in sequence. A solid arrow will indicate which band is selected.

2.7 FUNC KEY

Pressing the FUNC key will bring up the first functions menu:

F1 to F4 =	Channels	Pressing one of these keys will load a pre-programmed channel.
4 =	Record	Pressing 4 will cause the transceiver to record the next message received on the band selected.
5 =	Playback	Pressing 5 will play the last message recorded.

Pressing the FUNC key again will bring up the second menu.
The following functions are available:

1 =	Cross Band Repeat	You can select any two bands to cross band repeat. The repeat function is semi-duplex. This means the TDFM-7300 will retransmit from one band to another in both directions but not simultaneously.
2 =	Configuration	Enters the configuration menu (see 2.18 configuration menu). This is the same menu that can be invoked during boot up.
3 =	Simulcast	You can select bands to transmit simultaneously. Simulcast is not available when audio routing is set to separate mode and will not show up in the functions menu.
4 =	F1-F4 Programming	Allows you to program a Hot Memory (zone/channel) to the F1 to F4 keys for each band.
5 =	Simplex Repeat	When turned on, the band selected will become a simplex repeater. Simplex repeat (sometimes called parrot repeat) will record an incoming message and immediately retransmit the message on the same frequency.
6 =	PCDL Mode	When Band selector is set to Band 5, this switches the front panel program connector serial port to the Band 5 RF module. This is used when programming with MultiTDP software.

2.8 F1 to F4 KEYS

Four function keys at the top of the keypad provide the same actions as the three side buttons and the top button found on the XTS-5000 portable. They are as follows:

- F1** – Top-side-button (purple button) on the portable.
- F2** – Centre-side-button (with one dot) on the portable.
- F3** – Bottom-side button (with two dots) on the portable.
- F4** - Top button (orange button) on the portable.

TECHNISONIC INDUSTRIES LIMITED

www.til.ca

TDFM-7300-3 Transceiver Recommended Keypad Menu Defaults:

TDFM-7300-3 Series Transceiver ITEM	Portable ITEM	Conventional Operation	SmartNet / SmartZone Operation
F1 Key	Upper Side Button 1	Monitor	Unprogrammed
F2 Key	Middle Side Button 2	Nuisance Delete	Unprogrammed
F3 Key	Bottom Side Button 3	Talkaround/ Direct	Unprogrammed
F4 Key	Top Button	Volume Set Tone	Volume Set Tone
MUP and MDN keys	16-Position Rotary Knob	Channel Select	Talkgroup Select
ESW Key	Two-Position Concentric or Ergo Switch	Unprogrammed A (∅) Unprogrammed B (O)	Unprogrammed A (∅) Unprogrammed B (O)
TSW Key	Three-Position Toggle Switch	Blank (A) PL Disable (B) Scan (C)	Blank (A) PL Disable (B) Scan (C)

NOTE: It is possible to use Motorola's Customer Programming Software (CPS™) to alter the default keypad settings of the TDFM-7300-3 radio. However if custom key settings are chosen it will not be possible for Technisonic to help the Pilot or other Radio User through operational difficulties. These questions will have to be referred to the Radio System Administrator responsible for customising the settings. Technisonic recommends that the default key settings stay in place until all airframe installation and operational issues have been overcome.

TECHNISONIC INDUSTRIES LIMITED

www.til.ca

Bands 1 through 4 of the TDFM-7300-3 Transceiver are programmable by Motorola CPS™. The following settings may be programmed for each Conventional Channel in a module:

Tx Frequency	Zone
Tx PL/DPL Code	Channel
Rx Frequency	Name
Rx PL/DPL Code	RX Signal Voice Type
Time-Out Timer	TX Signal Voice Type
Scan List	Network Access Code
Phone Numbers	Tx Power
Talkgroup IDs	Private Call Type
Encryption Key Assignment	

The following settings can be programmed for each mode in a P25 Trunked and/or SmartNet/SMART ZONE equipped radio:

System Type	TG Strapping
System ID (NAC)	Zone
Individual ID (UID)	Scan List
Coverage Type	Scan Type
Affiliation Type	Interconnect
Control Channel (s)	Phone Display Format
Talkgroups	Private Call Operation
Status	Site Alias
Encryption Key Assignment	

The function keys along with the rest of the keypad, revert to normal number keys during transmit and when NUM LOCK is selected by pressing the rotary knob.

The F1 – F4 keys can be programmed as Hot Memory keys as mentioned in 2.7. Depending on the setting in the configuration menu, the keys can be permanently set to Hot Memories (channels) or used for other functions (normal). When the F1 –F4 keys are in the normal mode they can still be used for Hot Memory Recall if the FUNC key is pressed first.

2.9 MUP(4) AND MDN(7) KEYS (Memory Up and Down Keys)

These keys provide the same function as the rotary knob does when it is set to CHAN. This equates to the 16 position rotary knob on the portable. These keys can be used to scroll through the channels. A single press will step the channel by one, but a push and hold will scroll to a desired channel number. The function of the rotary knob is automatically set to CHAN when either of these keys is pressed.

2.10 UP(5) AND DN(8) KEYS

The keys provide the same function as the left and right arrow keys on the portable. The UP key equates to the right arrow key and the DN is the left. These keys are used for a variety of functions but in the normal mode they are used to scroll through the soft key menus.

2.11 BRT(6) AND DIM(9) KEYS

Use these keys to dim or brighten the display. The radio powers up at full brightness for normal use but can be dimmed for night operations.

2.12 ESW(0) KEY (Ergo Switch Key)

The ESW key provides the function of the concentric or 'ergo' switch on the portable. The switch has two conditions which are represented by 'O' and 'Ø'. Pressing the ESW key toggles the condition back and forth. The condition is displayed at the right hand side of the display line, second character from the right. The ergo switch condition is saved when the unit is turned off. There are separate conditions for each band installed. The ESW key can be programmed with the CPS™ to a variety of functions such as low power, scan and secure or encrypted mode.

2.13 TSW(*) KEY (Toggle Switch Key)

The TSW key provides the function of the toggle switch on the portable. The switch has three conditions which are represented by 'A', 'B' and 'C'. Pressing the TSW key toggles the condition A,B,C,A,B, etc. The condition is displayed at the far right hand side of the display line, last character on the right. The toggle switch condition is saved when the unit is turned off. There are separate conditions for each band installed. The TSW key can be programmed with the CPS™ to a variety of functions such as low power, scan, zone select, or pl disabled mode.

2.14 DISPLAY

The transceiver has a 6-line, 144-character LED display. The top 4 lines display the zone name, channel name, condition symbols (scan, direct, call, secure, monitor, etc) and switch settings for each band. An LED on the left side of each band indicates a receive condition while an LED on the right side of each line indicates transmit. A solid arrow on the first character indicates which band is selected. Line 5 displays information for the analog band including channel name, frequency, scan, narrow band, and tone. The sixth line displays the menu items associated with the band selected and the mode of the knob.

2.15 GENERAL OPERATION

Switch on the transceiver as described in 2.3. Select the desired band by pressing the BAND key. Select the TDFM-7300-3 on the aircraft audio panel. Press the knob again so that CHAN shows up on the bottom right of the display. Rotate the knob until the desired channel or talk group is selected. Press the knob until VOL is again shown on the display. You can adjust the volume by waiting until a signal is received or by pressing F1 (factory programmed for monitor function) and adjusting the rotary knob. The radio is ready to use. If the radio is installed in separate mode, remember that the band selected by pressing the BAND key is what menu is displayed on the screen but the band selected by the audio panel is band that you are actually transmitting and receiving on. To use the DTMF keypad while transmitting, the band you are using must be selected on the display.

TECHNISONIC INDUSTRIES LIMITED

www.til.ca

2.16 CUSTOMER PROGRAMMING SOFTWARE (CPS™)

Programming the Bands 1 – 4 of the TDFM-7300-3 is usually done with the use of third party programming software. Customer programming software or “CPS” must be supplied by Motorola.

To make any changes to the programming in the Type II radio, Motorola CPS™ software must be used. There is no provision in the TYPE II modules to allow the user to change frequencies, zones, PL tones etc. unless the Front Panel Programming (FPP) option has been purchased in each band.

A Programming cable is required to connect the computer to the TDFM-7300-3. Bands 1 - 4 in the TDFM-7300-3 are considered a XTS-5000 model III portable by the CPS™ software. To program a band in the transceiver, it must be selected by pressing the BAND key before running the CPS™. Follow the instructions supplied with the CPS™.

The CPS Programming software must be purchased from Motorola On Line (MOL).

For instructions on ordering Motorola parts and CPS software see TIB TIBFM 12-01 REV E.

This document is available on the Technisonic Web site at www.til.ca.

Follow the link for TDFM-7300-3 and click in the Link for “CPS Programming software/Cables ordering Guide”. Refer to the section for TYPE II modules.

Programming cables for units with Type II modules

The TDFM-7300-3 transceiver that employs type II modules requires a Technisonic programming cable, and Motorola “ASTRO 25 Portable CPS” Programming software, P/N RVN4181 (Latest revision) It does not require a Smart Rib Box. For the Analog band Technisonic Multi TDP software is required. Multi TDP is free and can be downloaded from the TIL website. Both software packages use the same cables.

If encryption keys need to be loaded via a KVL-3000+, keyloader cable P/N 037348-1 may be also be obtained from Technisonic. This keyloader cable will plug into the front mini DIN connector of the TDFM-7300-3 transceiver.

The following cables can be purchased from Technisonic:

- | | |
|--------------|---|
| P/N 047365-1 | TYPE II Download/Programming Cable that mates the 7300-3 front panel 8-pin mini DIN to PC computer 9 pin serial port (See Figure 2.2). |
| P/N 037348-1 | Encryption Keyload Cable that mates the 7300-3 front panel 8-pin Mini DIN with Motorola KVL-3000+ Keyloader. Same P/N for type I or type II modules. Refer to Figure 2.3. |

These above cables are designed for use with the TDFM-7300-3 while it is installed in the aircraft. An alternate cable can be used for programming if the radio is not installed and on the bench.

- | | |
|--------------|---|
| P/N 047366-1 | TYPE II Download/Programming Cable that mates with the TDFM-7300-3 DB 25 pin connector on the back and to the PC computer 9 pin serial port. This cable also provides power plugs to connect to a bench 28V power supply. |
|--------------|---|

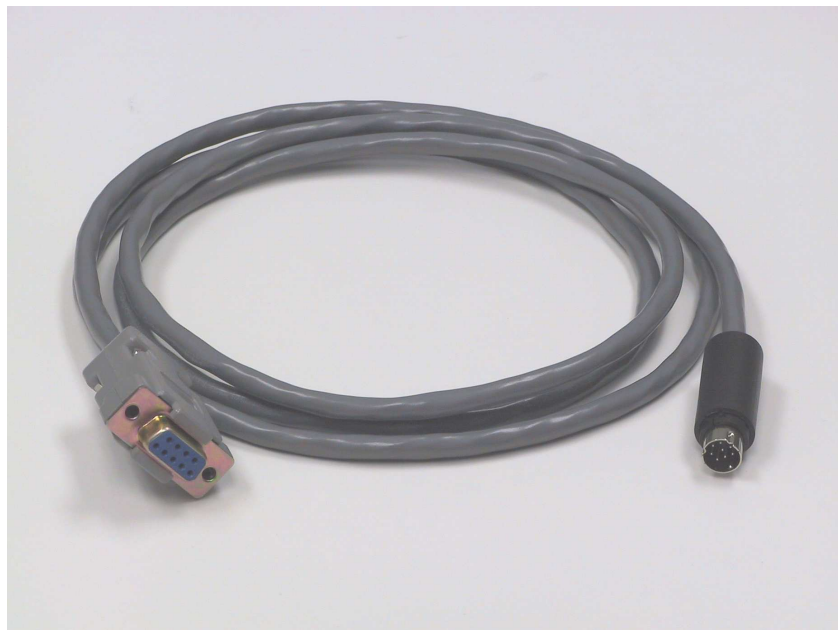

FIGURE 2.2: PC 7000(II) Programming cable for TYPE II radios P/N 047365-1



FIGURE 2.3: Encryption Keyload cable for TYPE II radios P/N 037348-1



FIGURE 2.4: PC 6000(II) Programming cable for TYPE II radios P/N 047366-1

Programming Using Computers With No Serial Ports

Newer PCs and laptops are now being made without serial ports. For those computers to program the TDFM-7300-3, a USB to serial adaptor will be required. USB to serial adaptors can be found at most computer stores.

To use the adaptor, plug in the USB cable and install the USB to serial driver on the target PC. The driver is usually supplied with the adaptor on a CD. This will create a "virtual serial port."

Once the adaptor is installed on the PC, find out what com port has been created by the adaptor. Usually it will be Com 3, Com 4 or Com 5. Refer to the PC's operating system "Device Manager".

The serial port will have to be set in the CPS software before programming can take place. Start the CPS software, then click on VIEW then OPTIONS. Click on the MAIN tab and go to the bottom pull down menu called "Port Selection". Select the com port that is the virtual port created by the adaptor. Click APPLY, then OK. The CPS should now work with the USB to serial adaptor.



FIGURE 2.5 USB to Serial Adaptor for Computers without Serial Ports

2.17 CONFIGURATION MENU:

Some features of the TDFM-7300-3 transceiver can be configured to the user's preference. To enter the configuration menu, turn the unit on while simultaneously pressing the F4, ESW and TSW keys. Hold the keys until the display reads 'Configuration Menu'. The following menu items can be changed or modified. Rotate the knob to select the desired condition and press the knob to continue to the next configuration item:

- Knob default -** This will select which mode (volume or channel) the knob will be when the radio is first turned on.
- Vol / Chan mode -** When set to both, volume and channel functions are both available while if set to single, only the function set in the above knob default will be available.
- Numlock mode -** When enabled, num lock mode is added to the available knob functions.
- Recall mode -** When enabled, recall is added to the available knob functions.
- Band 1 channels -** This number should be set to the highest channel number programmed in band 1 so that the channel scrolling wrap around will work properly up and down.
- Band 2 channels -** This number should be set to the highest channel number programmed in band 2 so that the channel scrolling wrap around will work properly up and down.
- Band 3 channels -** This number should be set to the highest channel number programmed in band 3 so that the channel scrolling wrap around will work properly up and down.
- Band 4 channels -** This number should be set to the highest channel number programmed in band 4 so that the channel scrolling wrap around will work properly up and down.

TECHNISONIC INDUSTRIES LIMITED

www.til.ca

- Squelch Blink -** When disabled, the squelch indicator lights will function normally. When enabled, the squelch lights will stay lit while a signal is present and then blink for a couple of seconds after the signal disappears. This can help to determine which band made the last call.
- Boot Speed -** When set to quick, some boot up messages will be skipped. When set to normal, all messages will be displayed.
- Panel Lighting –** Select 28 volts DC or 5 volts AC. No damage will occur if the wrong setting is made.
- F1-F4 Keys –** If set to normal, the keys will emulate the side buttons on the portable. If set to channels, the keys become quick channel load keys. The channels can be programmed in the second function menu.
- Sidetone 1 Level –** Sets the sidetone level for band 1. The microphone and headphone audio becomes live while in this mode to facilitate setting to a comfortable level
- Sidetone 2 Level –** Sets the sidetone level for band 2
- Sidetone 3 Level –** Sets the sidetone level for band 3
- Sidetone 4 Level –** Sets the sidetone level for band 4
- Sidetone 5 Level –** Sets the sidetone level for band 5

Press the knob to accept the setting. The radio will then power up normally. The radio will keep these settings until they are changed again by the configuration menu.

2.18 KEYLOADING MODE

If the TDFM-7300-3 is equipped with hardware encryption, then the Encryption keys will need to be loaded using a Motorola KVL 3000+® Keyloader.

Keyloading must be done by putting the transceiver into flash upgrade mode by turning on the radio while holding the HOME key. Select the band to be keyed-loaded by pressing the BAND key. Press the RESET Key to reset the modules and to put them into keyload mode. Wait until the display returns to the “Flash Upgrade mode” Power up the keyloader and plug the cable into the 7300-3 Program port. Follow the Motorola Keyloader instructions for uploading the actual keys to the radio.

If other bands require keys, press the BAND key to select the next module, wait 1 second for the module to sense the keyloader, then upload the key(s).

When keyloading is done, remove the keyloader cable and press the EXIT key to reboot the transceiver back to normal operation

2.19 FRONT PANEL PROGRAMMING (FPP) MODE (Bands 1 – 4)

One of the bands may have the capability to program channel information such as frequencies, PL tones, modulation types, etc from the front panel. 'FPP' will show up as one of the soft menu items at the bottom of the screen if this option has been ordered. When the FPP soft key is pressed, you will be prompted for channel information. Wait until the cursor is flashing then press 'OK' for the next input or press 'QUIT' to finish and get out of the programming mode. All changes up to that point will be saved. The prompts are as follows:

TX Frequency	Enter the desired transmit frequency using the numeric key pad. If the frequency entered is not within band limits or not on proper channel spacing, the frequency will automatically be changed to the closest valid channel.
RX Frequency	Enter the desired receive frequency.
TX PL	Enter the desired transmit PL tone frequency. After the last digit is pressed the radio will verify that it is a valid frequency and flash the first cursor again. Press 'OK' at this time. The transceiver supports all standard PL tones. (Also known as CTCSS tones) TXPL tones are generally used to open repeaters or in talk groups where the receivers are squelch protected by PL tones. Enter '000.0' for no tone. PL tones are used by analog mode only.
RX PL	Enter the desired receive PL tone frequency. Enter '000.0' no tone – carrier squelch operation.
TX DPL	Enter the desired DPL code. You can not have both a PL and a DPL at the same time. The one that is entered last will turn the other off. A DPL of 000 means off. DPL codes are also known as DCS codes.
RX DPL	Enter the receive DPL code as above.
TX NAC	Enter the desired transmit P25 NAC code if using digital, otherwise just press 'OK'. The code is hexadecimal therefore the letters A to F could also be used. Press the 'A-F' soft key to use buttons 1-6 as A-F. A NAC or Network Access Code is used like PL tones but are only used by P25 (digital) mode. A value of 293 is considered to be the standard code for open channel.
RX NAC	Enter the desired receive P25 NAC code as above.
RX TYPE	Select the receive mode using the UP and DN keys – Analog, digital or mixed. The mixed mode will allow the receiver to decode analog and P25 digital signals as needed.
TX TYPE	This prompt will only come up if you selected mixed for RX. Select analog or digital.
BANDWIDTH	Select 12.5, 20.0 or 25.0 kHz using the UP and DN keys. Bandwidth may also be called 'Channel Spacing'.
CHANNEL NAME	Use the UP and DN keys to scroll to the desired letter and press the NXT soft key to get to the next character. Press 'OK' when done. There will be a delay while the channel is saved, then the display will return to normal.

TECHNISONIC INDUSTRIES LIMITED

www.til.ca

The following is a list of TDFM-7300-3 CTCSS/PL/MOT CODES FOR BANDS 1 - 4:

PL(Hz)	MCODE	PL(Hz)	MCODE	PL(Hz)	MCODE	PL(Hz)	MCODE
67.0	XZ	97.4	ZB	141.3	4A	206.5	8Z
69.3	WZ	100.0	1Z	146.2	4B	210.7	M2
71.9	XA	103.5	1A	151.4	5Z	218.1	M3
74.4	WA	107.2	1B	156.7	5A	225.7	M4
77.0	XB	110.9	2Z	162.2	5B	229.1	9Z
79.7	WB	114.8	2A	167.9	6Z	233.6	M5
82.5	YZ	118.8	2B	173.8	6A	241.8	M6
85.4	YA	123.0	3Z	179.9	6B	250.3	M7
88.5	YB	127.3	3A	186.2	7Z	254.1	OZ
91.5	ZZ	131.8	3B	192.8	7A	CSQ	CSQ
94.8	ZA	136.5	4Z	203.5	M1		

TABLE 2.1 TDFM-7300-3 PL/MOT Codes

The following is a list of TDFM-7300-3 DCS/DPL CODES:

023	072	152	244	343	432	606	723
025	073	155	245	346	445	612	731
026	074	156	251	351	464	624	732
031	114	162	261	364	465	627	734
032	115	165	263	365	466	631	743
043	116	172	265	371	503	632	754
047	125	174	271	411	506	654	
051	131	205	306	412	516	662	
054	132	223	311	413	532	664	
065	134	226	315	423	546	703	
071	143	243	331	431	565	712	

TABLE 2.2 TDFM-7300-3 DPL Codes (All Bands)

TECHNISONIC INDUSTRIES LIMITED

www.til.ca

The following is a list of TDFM-7300-3 analog band CTCSS/PL TONES:

TONE #	PL (HZ)	TONE #	PL (HZ)	TONE #	PL (HZ)
0	CSQ	11	97.4	22	141.3
1	67.0	12	100.0	23	146.2
2	71.9	13	103.5	24	151.4
3	74.4	14	107.2	25	156.7
4	77.0	15	110.9	26	162.2
5	79.7	16	114.8	27	167.9
6	82.5	17	118.8	28	173.8
7	85.4	18	123.0	29	179.9
8	88.5	19	127.3	30	186.2
9	91.5	20	131.8	31	192.8
10	94.8	21	136.5	32	203.5

TONE #	PL (HZ)	TONE #	PL (HZ)	TONE #	PL (HZ)
33	33.0	44	56.8	55	199.5
34	35.4	45	58.8	56	206.5
35	36.6	46	63.0	57	210.7
36	37.9	47	69.4	58	218.1
37	39.6	48	150.0	59	225.7
38	44.4	49	165.5	60	229.1
39	47.5	50	171.3	61	233.6
40	49.2	51	177.3	62	241.8
41	51.2	52	183.5	63	250.3
42	53.0	53	189.9	64	CSQ
43	54.9	54	196.6		

TABLE 2.3 TDFM-7300-3 Analog Band CTCSS/PL Codes

2.20 FLASH UPGRADE MODE

NOTE: Flash upgrade mode only allows field upgrade for Bands 1 through 4. There is no flash upgrade for Band 5.

On occasion it may be required to flash upgrade one or more of the RF modules in the radio to change or add new features. This can be done using CPS software and a Motorola flash upgrade kit. The transceiver must be put into flash upgrade mode by turning on the radio while holding the HOME key. Select the band to be upgraded by pressing the band key. Press the RESET soft key. Wait until the display shows Flash upgrade mode again. The selected module is now ready to accept a flash upgrade. Follow the instruction supplied with the flash upgrade kit for configuring and using the CPS. When flash upgrade is completed, press the EXIT soft key to reboot the 7300-3 to normal operation. For detailed instructions refer to TIL document 106517 "FLASH UPGRADE PROCEDURE FOR TDFM 6000/7000/7300 SERIES RADIOS".

2.21 VHF LOW BAND (BAND 5) OPERATION – Analog Module Variances

Band 5 is an analogue only, VHF AM transceiver. Operation of band 5 differs slightly from the others in the following ways:

- 1) There are only 3 soft key menu items available:
 - FPP Allows programming of a channel as described in the above section minus the steps required for digital operation (NAC or TYPE). Wide and Narrow band channel spacing is selectable even though there is no such allocation on low band at this time.
 - SCAN Selecting this soft key will start band 5 scanning the channels in the scan list.
- 2) PC Uploading and Downloading channels to band 5 is accomplished using Technisonic's MultiTDP software which is supplied on a CD with the TDFM-7300-3 and from the TIL web site. (www.til.ca) The files are compatible with those used on our TFM-550 model. The same programming cable as is used for bands 1 through 4 is required. (047365-1)

For PC programming the TDFM-7300-3 must be put in to "PCDL Mode" via the function menu. Otherwise the MultiTDP software will not be able to communicate with Band 5.
- 3) The F1-F4, ESW and TSW keys have no function on band 5.
- 4) Band 5 is not included in the cross band repeat or simulcast feature.
- 5) There is no P25 digital mode. Band 5 is strictly an analog module only.

This page left intentionally blank.

SECTION 3 – INSTALLATION INSTRUCTIONS

3.1 GENERAL

This section contains information and instructions for the correct installation of the TDFM-7300-3 Transceiver.

3.2 EQUIPMENT PACKING LOG

Unpack the equipment and check for any damage that may have occurred during transit. Save the original shipping container for returns due to damage or warranty claims. Check that each item on the packing slip has been shipped in the container.

3.3 TRANSCEIVER INSTALLATION

The TDFM-7300-3 Transceiver is designed to be Dzus mounted and should be installed in conjunction with an IN-7300 installation kit. See Figure 3-1 for an outline drawing of the unit with dimensions to facilitate the installation.

3.4 INSTALLATION KIT - CONTENTS

The IN-7300 installation kit (P/N 069726-1) consists of:

1. One 25 pin Cannon D mating connector (female) complete with crimp pins and hood.
2. One 9 pin Cannon D mating connector (female) complete with crimp pins and hood.
3. One 15 pin Cannon high density D connector (female) complete with crimp pins and hood.
4. Five (5) BNC connectors.

3.5 ANTENNA INSTALLATION

The type and number of antennas depends on the model of transceiver being installed. The following is a list of recommended antennas for the various RF modules:

VHF	136 to 174 MHz Comant part # CI-292
UHFLO	403 to 470 MHz Comant part # CI-275
UHFHI	450 to 512 MHz Comant part # CI-275
UHFHI (II)	450 to 520 MHz Comant part # CI-285
800	806 to 870 MHz Comant part # CI-306
800/700 (II)	700 to 870 MHz Comant part # CI-285

Type II (II) modules have a wider bandwidth in some cases. If communications are going to occur in this wider bandwidth area, the antenna with wider coverage should be used.

The antenna should be mounted on the bottom of the aircraft whenever possible and must not be co-located (kept at a separation distance of more than 20cm from each other when installed). Also they must be installed in such a way that they always maintain a separation distance of more than 90cm (36 inches) from any from any occupant in the airframe during operation. Consult with instructions provided with the antenna. Connect the RF cables to the back of the transceiver using the BNC connectors provided in the installation kit. It is possible to use equivalent 50-ohm aviation antennas that cover the appropriate bandwidths. For IFR certified aircraft, it is recommended to use the Sensor Systems antenna for VHF low band along with a low pass filter to prevent harmonic interference with NAV equipment.

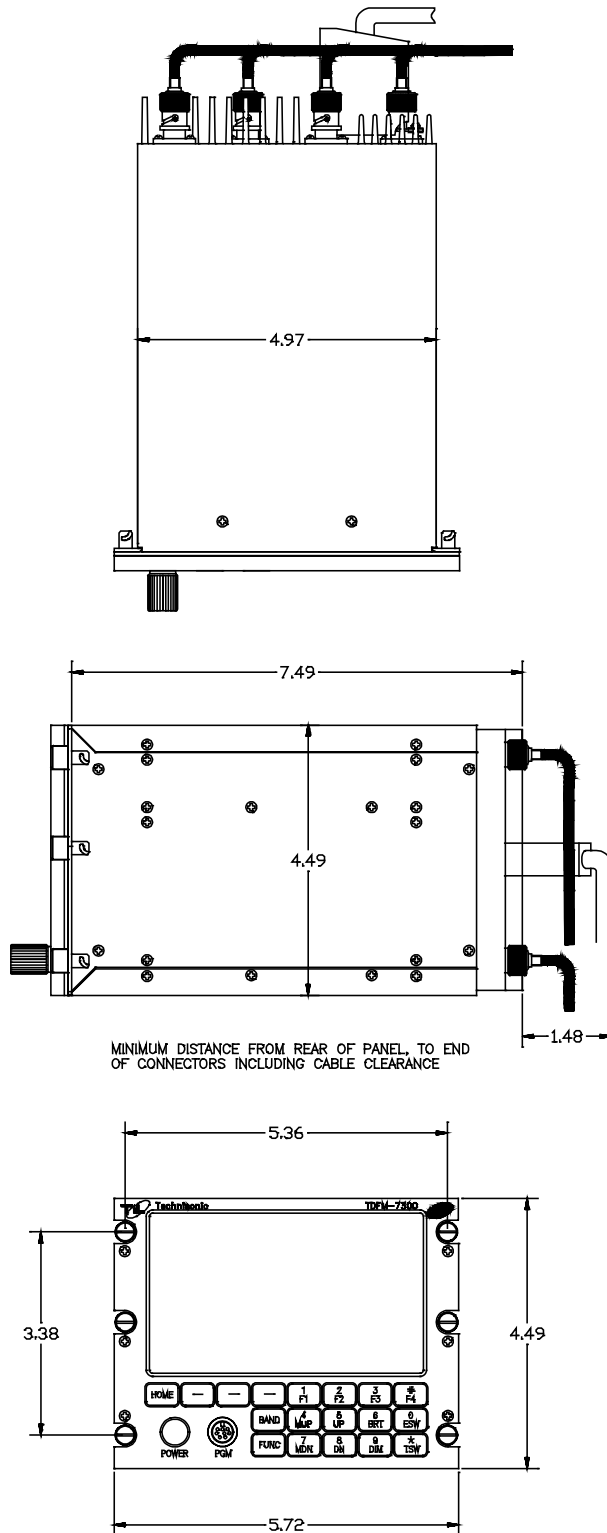

FIGURE 3-1 Outline Drawing for Model TDFM-7300-3

3.6 INSTALLATION - PIN LOCATIONS AND CONNECTIONS

J1 Connections (25 Pin FEMALE D Connector)	
Pin #	Description
1	Ground
2	Main Power +28 VDC
3	Mic 1
4	Audio 1
5	PTT 1
6	Mic 2
7	Audio 2
8	PTT 2
9	Mic 3
10	Audio 3
11	PTT 3
12	TX Data
13	RX Data
14	Ground
15	Main Power +28 VDC
16	Channel Up
17	Channel Down
18	LH Data
19	SB9600 Busy
20	OPTB+
21	CTS Out
22	Boot DIN
23	RTSBIN
24	RS232 DIN
25	Panel Backlighting

TABLE 3-1 Wire connections on a 25 Pin FEMALE D Connector

J2 Connections (9 Pin FEMALE D Connector)	
Pin #	Description
1	Ground
2	Audio Combined
3	PTT 4
4	PTT Combined
5	Audio 4
6	Mic 4
7	Mic Combined
8	On Power
9	Speaker Combined

TABLE 3-2 Wire connections on a 9 Pin FEMALE D Connector

TECHNISONIC INDUSTRIES LIMITED

www.til.ca

P1 Connections (15 Pin [high density] FEMALE D Connector)	
<u>Pin #</u>	<u>Description</u>
1	4 MHz
2	8 MHz
3	10 MHz
4	20 MHz
5	40 MHz
6	Audio 5
7	No connection
8	No connection
9	No connection
10	Tune Indicator
11	Speaker 5
12	Tune Enable
13	Ground
14	PTT5
15	Mic 5

TABLE 3-3 Wire connections on a 15 Pin [high-density] FEMALE D Connector

3.7 INSTALLATION (WIRING INSTRUCTIONS)

Figure 3-2 shows all required connections and recommended wire sizes for the TDFM-7300-3 transceiver.

3.8 MAIN GROUND: J1 (PINS 1 AND 14)

Both pins should be connected to ground. The main ground is internally connected to the chassis.

3.9 MAIN POWER: + 28VDC – J1 (PINS 2 AND 15)

Both pins should be connected to +28 volts DC +/- 15%.

3.10 MIC 1, 2, 3, 4 AND 5: J1 (PINS 3, 6, 9), J2 (PIN 6) AND P1 (PIN 15)

The microphone input signals shall be connected using shielded wire with the shield connected to ground (pin 1 or 14). It is recommended for best results to leave the other end of the shield floating to prevent ground currents unless you are connecting to an audio panel with floating hi and lo inputs (like the Technisonic A710 or A711 series) in which case the shield must be connected to the lo input.

3.11 AUDIO 1, 2, 3, 4, 5 AND COMBINED: J1(PINS 4, 7, 10) J2 (PINS 5, 2) AND P1 (PIN 6)

Audio outputs are 600 ohms impedance against ground. The output power is 600 mW maximum. Unused outputs do not have to be terminated and should be left unconnected.

TECHNISONIC INDUSTRIES LIMITED

www.til.ca

3.12 PTT 1, 2, 3, 4, 5 and COMBINED: J1 (PINS 5, 8, 11), J2 (PINS 3, 4) and P1 (PIN 14)

The PTT lines should be floating when in receive and grounded for transmit. The input has a pull up resistor to 5 volts. Connecting an audio panel that wishes to see more, may result in no receive audio. Connect a 1N4006 diode in series with the cathode towards the audio panel in this case.

3.13 TX DATA AND RX DATA: J1 (PINS 12 AND 13)

These pins provide RS-232 serial communications for use with the RC-7000 or RC-7300 remote control head if installed. Consult the RC-7300 installation manual for details.

3.14 CHANNEL UP / DOWN: J1 (PINS 16 AND 17)

These pins can be used to scroll up and down through the zone/channel/mode/talk group selections for the band currently displayed on the screen. The inputs normally floating are grounded to activate. Two push buttons or a center off, SPDT, spring loaded toggle switch are typically used on these inputs. If both pins are grounded simultaneously, the next band will be selected.

3.15 LH DATA, SB9600 BUSY, OPTB+, CTS OUT, BOOT DIN, RTSBIN AND RS232DIN:

J1 (PINS 18 THROUGH 24)

These pins are used for programming or updating the transceiver using Motorola Customer Programming Software (CPS™) or encryption key loading and are left unconnected. They may be used to update the radio once it is removed from the aircraft. These pins are also brought out to the TDFM-7300-3's front panel mini-DIN connector to allow programming in the aircraft.

3.16 PANEL BACKLIGHTING: J1 (PIN 25)

Connect to aircraft panel dimming bus. The transceiver is capable of supporting 28 VDC or 5 VAC backlighting circuits. Select 28 volts DC or 5 volts AC via the configuration menu (see section 2.18). No damage will occur if the wrong setting is made.

3.17 ANTENNA TUNER CONTROL LINES: P1 (PINS 1, 2, 3, 4, 5, 6, 10 AND 12)

These connections are not used on the TDFM-7300-3.

3.18 POWER JUMPER

The radio must be turned on manually each time the avionics bus is switched on. If it is desired that the radio comes on with the radio master in the aircraft, remove the right side panel from the radio and install the supplied 0.1" jumper across JP1 (two pins) near the rear of the radio on the right side of the MCU board. The radio is shipped with the jumper on only one of the two pins. If you attempt to turn off the radio with the jumper installed, it will come back on again in 5 seconds. Turning the avionics bus or battery master switch off will be required to de-energize the radio.

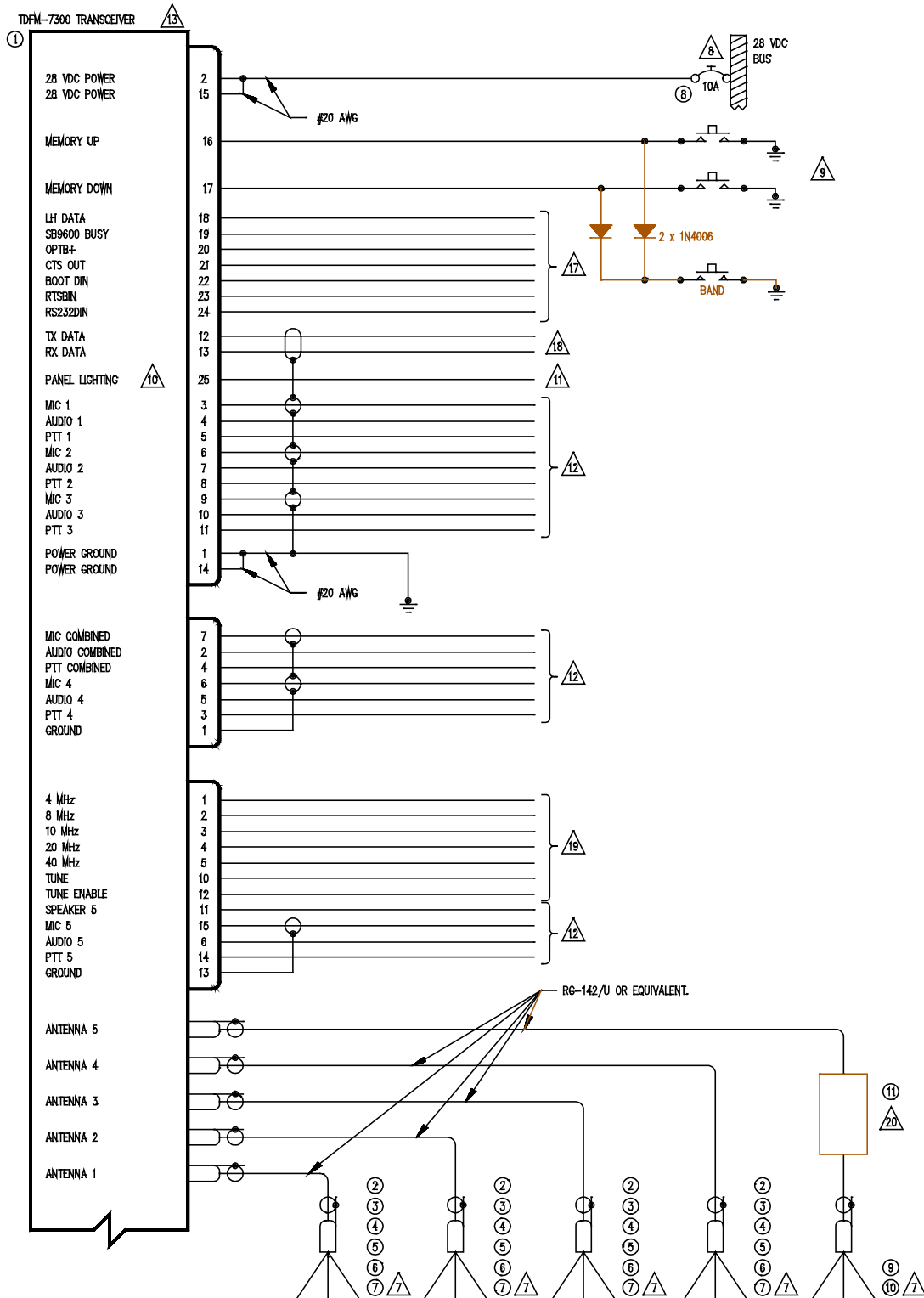

FIGURE 3-2a Wiring connections for the TDFM-7300-3 Transceiver

TECHNISONIC INDUSTRIES LIMITED

www.til.ca

QTY	ITEM	PART NUMBER	DESCRIPTION	SPEC	MATERIAL
1	1	TDFM-7300	MULTIBAND FM COMMUNICATIONS TRANSCEIVER.	TECHNISONIC INDUSTRIES LIMITED	
1	2	CI-292	VHF ANTENNA, 136 TO 174 MHZ	COMANT INDUSTRIES	
1	3	CI-275	UHFLO ANTENNA, 403 TO 470 MHZ	COMANT INDUSTRIES	
1	4	CI-275	UHFHF ANTENNA, 460 TO 512 MHZ	COMANT INDUSTRIES	
1	5	CI-285	VHFH (II) ANTENNA, 450 TO 520 MHZ	COMANT INDUSTRIES	
1	6	CI-306	800 ANTENNA, 806 TO 870 MHZ	COMANT INDUSTRIES	
1	7	CI-285	800/700 (I) ANTENNA, 700 TO 870 MHZ	COMANT INDUSTRIES	
1	8	7274-11-10	CIRCUIT BREAKER, 10 AMPS	KLIXON	
1	9	FLX-3050B	ANTENNA/ANTENNA TUNER, 30 TO 50 MHz	FOXTRONICS	
1	10	S65-8282-34	ALTERNATE ANTENNA, 30 TO 50 MHz	SENSOR SYSTEMS	
1	11	061244-1	LOW PASS FILTER	TECHNISONIC INDUSTRIES LIMITED	

NOTES:

- 1) ALL WIRE IAW MIL-W-22759 UNLESS OTHERWISE SPECIFIED.
- 2) ALL CABLE IAW MIL-C-27500 UNLESS OTHERWISE SPECIFIED.
- 3) COAXIAL CABLE IAW MIL-C-17 UNLESS OTHERWISE SPECIFIED. DO NOT USE COAX WITH PVC INSULATION.
- 4) FABRICATION & INSTALLATION OF WIRING HARNESS IAW AC 43.13-1B CHAPTER 11.
- 5) GROUNDING AND BONDING IAW AC 43.13-1B CHAPTER 11, SECTION 15.
- 6) ALL SINGLE WIRE TO BE #22 AWG MINIMUM AND ALL SHIELDED WIRE TO BE #24 AWG MINIMUM, UNLESS OTHERWISE SPECIFIED.
- 7) INSTALLATION OF ANTENNA IAW AC 43.13-1B CHAPTER 4, SECTION 4, CHAPTERS 6 & 7, AND AC 43.13-2A CHAPTER 3. IF POSSIBLE, THE ANTENNA SHOULD BE LOCATED A MINIMUM OF 12 FT FROM AIRCRAFT NAVIGATION RECEIVER ANTENNAS AND A MINIMUM OF 4 FEET FROM AIRCRAFT COMMUNICATIONS AND ELT ANTENNAS. BE CAREFUL NOT TO CHOSE SEPARATIONS THAT CLOSELY APPROXIMATE 1/4 OR 1/2 OR WHOLE NUMBER MULTIPLES OF THE NAVIGATION OR COMMUNICATIONS WAVELENGTH.
- 8) AN EQUIVALENT CIRCUIT BREAKER OR FUSE MAY BE USED.
- 9) THE MEMORY UP/DOWN PUSH BUTTONS ARE OPTIONAL.
- 10) THIS INPUT IS FOR BOTH 28 VDC AND 5 VAC PANEL LIGHTING. SELECT THE APPROPRIATE VOLTAGE IN THE CONFIGURATION MENU. SEE PARA 2.18.
- 11) CONNECT TO THE APPROPRIATE AIRCRAFT DIMMING BUSS.
- 12) CONNECT TO THE AIRCRAFT AUDIO SYSTEM OR STAND-ALONE HEADSET JACKS.
- 13) INSTALLATION OF TRANSCEIVER IAW AC 43.13-1B CHAPTER 4, SECTION 4 AND AC 43.13-2A, CHAPTER 2. PR3 1/2 DZUS RAIL OR EQUIVALENT MAY BE USED.
- 14) TEST THE SYSTEM IN ACCORDANCE WITH THE POST-INSTALLATION TEST PROCEDURE IN THE INSTALLATION AND OPERATING INSTRUCTIONS MANUAL.
- 15) REFER TO THE AIRCRAFT STRUCTURAL REPAIR MANUAL AND THE MAINTENANCE MANUAL FOR INSTRUCTIONS AND INFORMATION PERTINENT TO THIS INSTALLATION.
- 16) THE USE OF RED DISPLAYS SHOULD BE MINIMIZED OR AVOIDED SO AS NOT TO DETRACT FROM THE ATTENTION GETTING CHARACTERISTICS NEEDED IN WARNING AND CAUTION ANNUNCIATORS. RED SHOULD BE USED TO ANNUNCIATE EMERGENCY CONDITIONS REQUIRING IMMEDIATE RESPONSE BY THE FLIGHT CREW. UNITS WITH RED DISPLAYS SHOULD NOT BE LOCATED IN CLOSE PROXIMITY TO WARNING AND CAUTION ANNUNCIATORS. THE INSTALLATION OF UNITS WITH RED DISPLAYS MUST BE EVALUATED ON A CASE BY CASE BASIS TO ENSURE THAT THE EFFECTIVENESS OF THE WARNING AND CAUTION ANNUNCIATORS IS NOT ADVERSELY AFFECTED.
- 17) NOT NORMALLY USED IN AIRCRAFT.
- 18) CONNECTION TO AN OPTIONAL RC-7300 SLAVE CONTROL HEAD.
- 19) CONNECTION TO AN OPTIONAL LOW BAND ANTENNA TUNER.
- 20) FOR IFR CERTIFIED AIRCRAFT, IT IS RECOMMENDED TO USE THE ALTERNATE SENSOR SYSTEMS ANTENNA IN COMBINATION WITH THE TECHNISONIC LOW PASS FILTER TO PREVENT HARMONIC INTERFERENCE WITH NAV EQUIPMENT.

FIGURE 3-2b Wiring connections notes for the TDFM-7300-3 Transceiver

This page left intentionally blank.

3.19 POST INSTALLATION EMI TEST

PURPOSE

The purpose of this test is to identify any interference that the TDFM-7300-3 transceiver may cause with existing aircraft systems.

TEST CONDITIONS

The TDFM-7300-3 transceiver should be installed and function tested. The antenna VSWR should be checked. A forward/reverse power check with an in-line wattmeter should show no more than 10% reflected power. For the following tests, insure that the output power is set to high.

METHODOLOGY

Most of the EMI tests can be accomplished on the ground. In some cases flight testing is required or is easier. If the aircraft is approved for IFR operations, then it is mandatory that interference between the TDFM-7300-3 transceiver and the approach aids be checked in flight.

The GPS should be operational and navigating with at least the minimum compliment of satellites. The VHF comm should be set to the frequencies indicated with the squelch open. VOR/DME receivers should be set to the frequencies indicated and selected for display. If possible, set up a DME ramp test set on the frequencies indicated and adjust the output until the flags are out of view. The transponder and encoder should be monitored with ramp test equipment. Set the output of the transponder test set to 3db above the output necessary to achieve 90% reply. If possible set the ADF to a nearby navigation station.

Modulate the TDFM-7300-3 transmitter on the indicated frequencies for at least 20 seconds.

Observe the GPS for any degradation in satellite status or availability or flags. Listen for any noise or detected audio signals on the VHF comm(s). Listen for any noise or detected audio signals on the VOR/LOC receiver audio; look for any moment of flags or needles on the VOR/LOC/GS navigation display(s). Observe the transponder for any loss of reply or spurious reply.

List the power plant, fuel and other electric instruments in the chart provided and note any anomalies that occur while transmitting. Assess the results.

If the aircraft is equipped with an autopilot or a stability augmentation system, then test fly the aircraft and verify that operation of the TDFM-7300-3 transceiver does not have adverse effects on these systems. After checking for gross effects at a safe altitude, fly an approach with each of the different navigation systems coupled to the autopilot (ILS, GPS ETC.) and look for any anomalies.

TECHNISONIC INDUSTRIES LIMITED

www.til.ca

RESULTS

If the installed system passes all of the applicable EMI tests, then no further action is required. If interference is observed then the interference must be assessed against the appropriate standards of airworthiness for the system in question. For example it is permissible for a VFR certified GPS to lose navigation capability while the TDFM-7300-3 unit is transmitting, providing that it recovers properly and promptly, but it is not permissible for an IFR Approach certified GPS to be affected in the same way. A complete discussion of all the standards of airworthiness to be applied in assessing EMI effects is beyond the scope of this document.

PROCEDURE

- A. Operate the TDFM-7300-3 transmitter on the following frequency for at least 20 seconds. Observe the GPS for any degradation in satellite status or availability or flags.

FREQUENCIES	GPS #1		GPS #2	
	PASS	FAIL	PASS	FAIL
143.2125 MHz				
143.2250 MHz				
157.5375 MHz				
157.5500 MHz				
512.0000 MHz				

NOTES:

TECHNISONIC INDUSTRIES LIMITED

www.til.ca

- B.** Determine if the image frequency for the VHF Comm falls within the range of the TDFM-7300-3. If so, select a set of frequencies that will cause the TDFM-7300-3 to be set as close as possible to the image frequency. Any one of the many possible sets will suffice. Record those values in the spaces provided in the following chart. Modulate the TDFM-7300-3 transmitter on the following frequencies for at least 20 seconds. Listen for any noise or detected audio signals on the VHF comm.

Example - Bendix /King KY 196A:

The first IF frequency is 11.4 MHz. The L.O. is above the received frequency (high side injection), therefore the image frequency is 22.8 MHz above the selected frequency. Set the KY 196A to 120.000 MHz and the TDFM-7300-3 to 142.8000 MHz.

FREQUENCIES		RESULTS	
VHF #1	TDFM-7300-3	PASS	FAIL
135.975	136.0000		
121.150	157.5000		
131.250	157.5000		
Image:			

FREQUENCIES		RESULTS	
VHF #1	TDFM-7300-3	PASS	FAIL
135.975	136.0000		
121.150	157.5000		
131.250	157.5000		
Image:			

NOTES:

TECHNISONIC INDUSTRIES LIMITED

www.til.ca

- C.** Determine if the image frequency for the VOR/ILS Nav falls within the range of the TDFM-7300. If so, select two sets of frequencies that will cause the TDFM-7300-2 to be set as close as possible to the image frequency. Choose one set in the localizer frequency range and one in the VOR frequency range. Record those values in the spaces provided in the following chart. Modulate the TDFM-7300-2 transmitter on the following frequencies for at least 20 seconds. Listen for any noise or detected audio signals on the receiver audio; look for any moment of flags or needles on the navigation display.

FREQUENCIES		RESULTS	
VOR/ILS #1	TDFM-7300-3	PASS	FAIL
108.000	162.0000		
108.100	162.1500		
Image:			

FREQUENCIES		RESULTS	
VOR/ILS #2	TDFM-7300-3	PASS	FAIL
108.000	162.0000		
108.100	162.1500		
Image:			

NOTES:

TECHNISONIC INDUSTRIES LIMITED

www.til.ca

- D.** The following procedure checks for second harmonic interference to the glide slope receiver from the TDFM-7300-3. All transceivers produce harmonics (multiples of the wanted frequency) and while the TDFM-7300-3 far exceeds FCC requirements, interference can still be experienced depending upon antenna position and separation. Furthermore, harmonics can be generated by other equipment in the aircraft and the structure of the aircraft where dissimilar metals make contact or where grounds are isolated, etc. This is also true of aircraft hangars, therefore testing should be done outside away from any structures where possible.

With a portable glide slope generator, provide enough signal to firmly activate the indicator needle and hide all flags. Increase the signal level by 3 dB. Modulate the TDFM-7300-3 transmitter on the following frequencies for at least 20 seconds. Observe the Glide Slope displays. Look for any movement of flags or needles on the navigation display. If an interference condition is detected, then the installation will have to be flight tested according to the following procedure. Using the table below, determine the glide slope frequency based on the localizer frequency of the ILS to be used. Divide the glide slope frequency by 2 and program into the TDFM-7300-3. Fly the aircraft to intercept the localizer and glide slope (both needles centered) at 26 nm from the runway. Transmit on the TDFM-7300-3 for 10 seconds and watch for any deflections or flags. Repeat the test every 2 nm until the indicators are not affected. If the distance is greater than 18 nm then a pass shall be recorded. Otherwise the TDFM-7300-3 shall be placarded "Do not transmit while on ILS approach".

<u>Localizer</u>	<u>Glide slope</u>	<u>Localizer</u>	<u>Glide slope</u>
108.10	334.70	110.10	334.40
108.15	334.55	110.15	334.25
108.30	334.10	110.30	335.00
108.35	333.95	110.35	334.85
108.50	329.90	110.50	329.60
108.55	329.75	110.55	329.45
108.70	330.50	110.70	330.20
108.75	330.35	110.75	330.05
108.90	329.30	110.90	330.80
108.95	329.15	110.95	330.65
109.10	331.40	111.10	331.70
109.15	331.25	111.15	331.55
109.30	332.00	111.30	332.30
109.35	331.85	111.35	332.15
109.50	332.60	111.50	332.90
109.55	332.35	111.55	332.75
109.70	333.20	111.70	333.50
109.75	333.05	111.75	333.35
109.90	333.80	111.90	331.10
109.95	333.65	111.95	330.95

FREQUENCIES		RESULTS	
G/S #1	TDFM-7300-3	PASS	FAIL

TECHNISONIC INDUSTRIES LIMITED

www.til.ca

334.7 (108.1)	167.35		
334.7 (108.1)	33.47		

FREQUENCIES		RESULTS	
G/S #2	TDFM-7300-3	PASS	FAIL
334.7 (108.1)	167.35		
334.7 (108.1)	33.47		

NOTES:

- E.** Operate the TDFM-7300-3 transmitter on the following frequency for at least 20 seconds. Observe the Transponder for any spurious replies or loss of reply to test set.

FREQUENCIES	TRANSPONDER #1		TRANSPONDER #2	
	PASS	FAIL	PASS	FAIL
512 MHz				

NOTES:

TECHNISONIC INDUSTRIES LIMITED

www.til.ca

- F.** Modulate the TDFM-7300-2 transmitter on the following frequencies for at least 20 seconds. Observe the DME displays. Look for loss of distance information on the display.

FREQUENCIES		RESULTS	
DME 1	TDFM-7300-3	PASS	FAIL
978 (108.0)	489		
1020 (112.1)	510		

FREQUENCIES		RESULTS	
DME 2	TDFM-7300-3	PASS	FAIL
978 (108.0)	489		
1020 (112.1)	510		

NOTES:

NOTES:

TECHNISONIC INDUSTRIES LIMITED

www.til.ca

G. For the following tests, select a frequency at the top, middle and bottom of each band of the TDFM-7300-3 transceiver.

	136 to 178 MHz Band	403 to 470 MHz Band	450 to 512 MHz Band	806 to 870 MHz Band
Frequency #1				
Frequency #2				
Frequency #3				

H. At a safe altitude engage the autopilot or stability augmentation system. Modulate the TDFM-7300-3 transmitter on the above frequencies for at least 20 seconds. Observe any effect on the autopilot or stability augmentation system.

Observations:

I. Perform a coupled ILS approach to the aircraft's certified limits. Modulate the TDFM-7300-3 transmitter on the above frequencies for at least 20 seconds. Observe any effect on the autopilot. Repeat for second flight director/autopilot if equipped.

Observations:

TECHNISONIC INDUSTRIES LIMITED

www.til.ca

J. List the power plant, fuel and other electric instruments in the chart provided and note any anomalies that occur while transmitting. Assess the results.

STEP	SYSTEM	PASS	FAIL	NOTES
1	Com 1&2 (UHF Lo, UHF Hi, and 800 MHz)			
2	Transponder & Encoder (VHF, UHF Lo, and 800 MHz)			
3	ADF 1 & 2			
4	VG			
5	Glideslope 1&2 (UHF Lo, UHF Hi, and 800 MHz)			
6	VOR/LOC 1&2 (UHF Lo, UHF Hi, and 800 MHz)			
7	Compass			
8	Directional Gyro			
9	Fuel Pressure			
10	Oil Temp			

TECHNISONIC INDUSTRIES LIMITED
www.til.ca

11	Amps			
12	Bus Voltage			
13	Fuel %			
14	Ng			
15	TOT			
16	Torque %			
17	Annunciators			
18	Digital Clock			
19	Oil Pressure			
20	DME 1&2 (VHF, UHF Lo, and 800 MHz)			
21	GPS 1&2 (UHF Lo and 800 MHz)			

TECHNISONIC INDUSTRIES LIMITED
www.til.ca

STEP	SYSTEM	PASS	FAIL	NOTES

NOTES:

Technisonic Industries Limited

240 Traders Blvd., Mississauga, ON Canada L4Z 1W7

Tel: (905) 890-2113 Fax: (905) 890-5338

**IMPORTANT
WARRANTY**

All communication equipment manufactured by Technisonic Industries Limited is warranted to be free of defects in Material or Workmanship under normal use for a period of one year from Date of Purchase by the end user.

Warranty will only apply to equipment installed by a factory approved and/or authorized facility in accordance with Technisonic published installation instructions. Equipment falling under the following is not covered by warranty:

- equipment that has been repaired or altered in any way as to affect performance,
- equipment that has been subject to improper installation,
- equipment that has been used for purposes other than intended,
- equipment that has been involved in any accident, fire, flood, immersion or subject to any other abuse.

Expressly excluded from this warranty are changes or charges relating to the removal and re-installation of equipment from the aircraft. Technisonic will repair or replace (at Technisonic's discretion) any defective transceiver (or part thereof) found to be faulty during the Warranty Period.

Faulty equipment must be returned to Technisonic (or its authorized Warranty Depot) with transportation charges prepaid. Repaired (or replacement) equipment will be returned to the customer with collect freight charges. If the failure of a transceiver occurs within the first 30 days of service, Technisonic will return the repaired or replacement equipment prepaid.

Technisonic reserves the right to make changes in design, or additions to, or improvements in its products without obligation to install such additions and improvements in equipment previously manufactured. This Warranty is in lieu of any and all other warranties express or implied, including any warranty of merchantability or fitness, and of all other obligations or liabilities on the part of Technisonic.

This Warranty shall not be transferable or assignable to any other persons, firms or corporations.

**For warranty registration please complete the on-line
Warranty Registration Form found at www.til.ca.**