

# **VHF/FM AIRBORNE TRANSCEIVER MODEL TFM-500**

**(P/N's 971083-1,3 -VHF Guard Module)**

## **Installation and Operating Instructions**

**Til Document No.  
98RE243  
Rev. N/C  
Issue 1**

**JANUARY 1999**

### **Technisonic Industries Limited**

**250 Watline Avenue, Mississauga, Ontario L4Z 1P4 Tel:(905)890-2113 Fax:(905)890-5338  
3840 East Robinson Road, Suite 214, Amherst, New York 14228 Tel:(716)691-0669**

## CAUTION

This unit contains static sensitive devices. Wear a grounded wrist strap and/or conductive gloves when handling printed circuit boards.

***NOTE: This equipment has been tested and found to comply with the limits for a Class A digital device, pursuant to Part 15 of the FCC Rules. These limits are designed to provide reasonable protection against harmful interference when the equipment is operated in a commercial environment. This equipment generates, uses, and can radiate radio frequency energy and, if not installed and used in accordance with the instruction manual, may cause harmful interference to radio communications. Operation of this equipment in a residential area is likely to cause harmful interference in which case the user will be required to correct the interference at his own expense.***

### Warning:

Changes or modifications not expressly approved by Technisonic Industries could void the user's authority to operate the equipment.

## WARRANTY INFORMATION

The Model TFM-500, Transceiver is under warranty for one year from date of purchase. Failed units caused by defective parts, or workmanship should be returned to:

Technisonic Industries Limited  
250 Watline Avenue  
Mississauga,  
Ontario L4Z 1P4

Technisonic Industries Limited  
3840 E. Robinson Road, Suite 214  
Amherst,  
New York 14228

Tel: (905) 890-2113 Fax: (905) 890-5338

Tel: (716) 691-0669

## TABLE OF CONTENTS

Paragraph	Title	Page
<b>SECTION 1 GENERAL DESCRIPTION</b>		
1.1	Introduction . . . . .	1-1
1.2	Description . . . . .	1-1
1.3	Purpose of Equipment . . . . .	1-1
1.4	Model Variation . . . . .	1-2
1.5	Technical Summary . . . . .	1-2
<b>SECTION 2 OPERATING INSTRUCTIONS</b>		
2.1	Operating Features . . . . .	2-1
2.2	Operating Instructions . . . . .	2-1
2.3	Programming Instructions . . . . .	2-5
2.4	Scanning Function . . . . .	2-6
2.5	Priority and Selective Memory Channel Scanning . . . . .	2-6
2.6	Direct Frequency Entry Mode . . . . .	2-6
2.7	Receive Frequency Simplex Function . . . . .	2-7
2.8	Keyboard Lockout Function . . . . .	2-7
2.9	Variable Frequency Mode Function . . . . .	2-7
2.10	LED Display Variable Dimming Mode . . . . .	2-7
2.11	90 Second Transmitter Time Out Feature . . . . .	2-7
2.12	Quick Guard Programming Feature . . . . .	2-7
2.13	Programming CTCSS Tones . . . . .	2-8
2.14	PC Memory/Programming Download Capability . . . . .	2-9
<b>SECTION 3 INSTALLATION INSTRUCTIONS</b>		
3.1	General . . . . .	3-1
3.2	Equipment Packing Log . . . . .	3-1
3.3	Transceiver Installation . . . . .	3-1
3.4	Installation Kit - Contents . . . . .	3-1
3.5	Antenna Installation . . . . .	3-1
3.6	Installation - Pin Locations and Connections . . . . .	3-1
3.7	Wiring Instructions . . . . .	3-3
3.7.1	Main Power +28VDC . . . . .	3-3
3.7.2	Main Ground . . . . .	3-3
3.7.3	PTT (Ground Keying) . . . . .	3-3
3.7.4	Front Panel Back Lighting . . . . .	3-5
3.7.5	Audio Outputs (600 and 4 Ohms) . . . . .	3-5
3.7.6	Audio Output Ground . . . . .	3-5
3.7.7	Mic Signal Input . . . . .	3-5
3.7.8	Memory Up/Memory Down . . . . .	3-5
3.7.9	Data Input . . . . .	3-5
3.8	Internal Programming and Guard Enable/Disable Jumper . . . . .	3-5
3.9	Transmitter Power Adjustments . . . . .	3-7
3.10	Transmitter Microphone Level Adjustment . . . . .	3-7
3.11	Transmitter Sidetone Level Adjustment . . . . .	3-7
3.12	Main and Guard Squelch Adjustment . . . . .	3-9
3.13	Transmitter Deviation Adjustment . . . . .	3-9
3.14	Guard Receiver Audio Limit Feature . . . . .	3-9

## LIST OF TABLES

Table No.	Title	Page
3-1	9-pin D and 15-Pin D Connections . . . . .	3-3

## LIST OF ILLUSTRATIONS

Figure No.	Title	Page
2-1	Operator's Switches and Controls . . . . .	2-3
2-2	PC Up/Download Cable - Wiring Diagram . . . . .	2-12
3-1	Outline Drawing . . . . .	3-2
3-2	Wiring Connections . . . . .	3-4
3-3	Internal Enable/Disable Jumper Locations . . . . .	3-7
3-4	External Adjustment Access Holes . . . . .	3-8
3-5	Deviation Adjustment Potentiometer Location . . . . .	3-10

## GENERAL DESCRIPTION

### 1.1 INTRODUCTION

This publication provides operating and installation information on the TFM-500 Transceiver, manufactured by Technisonic Industries Limited. The unit offers an extended frequency range with selectable channel spacing and is intended for use (in the U.S.) only by government agencies or contractors thereto, who have obtained licensing for operation in the 138-150 MHz portion of the band. If the TFM-500 transceiver is used in CANADA, VHF operation is restricted to the following sub bands: 138-144, 148-148.99, 149.005-150.005 and 150.05-174 MHz.

### 1.2 DESCRIPTION

The TFM-500, Transceiver is a frequency agile, fully synthesized airborne transceiver capable of operating in the 138 to 174 MHz and 403 to 512 MHz frequency range in 2.5 kHz increments with either 25 kHz or 12.5 kHz channel spacing. The Transceiver can operate without restriction on any split frequency pair in either band and also incorporates a two channel VHF synthesized guard receiver.

The TFM-500 Transceiver provides 200 operator accessible memory positions per band, each of which is capable of storing a transmit frequency, receive frequency, transmit frequency CTCSS tone or DPL code, receive frequency CTCSS tone or DPL code, an alphanumeric identifier for each channel and wideband (25 kHz) or narrowband (12.5 kHz) channel spacing assignment. Operating frequency and other related data are presented on a 96 character, four line LED matrix display. Data entry and function control are performed via a 12 button keypad. Preset channels may also be scrolled and scanned through keypad function activation. Data may also be entered via an MS-DOS based computer with the provided software and optional PC Up/download cable, P/N 9xxxxxxx.

### 1.3 PURPOSE OF EQUIPMENT

The TFM-500, VHF/UHF FM Transceiver is designed to provide secondary airborne communications to facilitate operations which are typically performed in a low altitude environment. The transmitter sections of this unit have a minimum of 8 watts and do not exceed 10 watts output power, which may be reduced by a front panel switch to 1 watt, in order to reduce interference to land based systems.

### 1.4 MODEL VARIATION

There are four variations of the Model TFM-500 Transceiver. All units offer identical features and performance except for the following differences:

TFM-500, P/N 971083-1	GREEN display and 28 Volt back lighting.
TFM-500, P/N 971083-1 (5V),	GREEN display and 5 Volt back lighting.
TFM-500, P/N 971083-3	RED display and 28 Volt back lighting.
TFM-500, P/N 971083-3 (5V),	RED display and 5 Volt back lighting.

Both P/N's 971083-1 and 971083-3 are always provided with 28 Volt back lighting unless a specific request is made for 5 Volt AC operation.

## 1.5 TECHNICAL CHARACTERISTICS

<u>Specification</u>	<u>Characteristic</u>
<b><u>GENERAL</u></b>	
Model Designation:	TFM-500
Frequency Range:	138 to 174 and 403 to 512 MHz
Tuning Increments:	2.5 kHz
Operating Mode:	F3E simplex or semi-duplex
Channel Spacing:	25 or 12.5 KHz
Physical Dimensions (including heatsink):	Approx. 8.0" X 3.0" X 5.75"
Weight:	Approx. 5.1 Lbs (2.3 Kg)
Mounting:	Panel Mount via Dzus fastners
Operating Temperature Range:	-40°C to +60°C
Power Requirement:	
Voltage:	28.0 Vdc, $\pm$ 15%
Current:	Receive - 1.0 A Max. 1 Watt Transmit - 2.0 A Max. 8-10 Watt Transmit - 3.2 A Max. 8-10 Watt Dual Transmit - 5 A Max.
Frequency Selection:	200 memories per band programmed with: a) Tx Frequency/Rx Frequency b) Tx/Rx CTCSS tone or DPL code c) 9 character alpha numeric title
Guard Receiver:	2 channels programmed with: a) Tx Frequency/Rx Frequency b) Tx CTCSS tone or DPL code c) 9 character alpha numeric title
CTCSS squelch/encoder:	All CTCSS tones available
DPL digital squelch/encoder:	All standard DPL codes
DTMF encoder:	All standard DTMF tones
Audio Outputs:	0.5 Watts into 600 ohms
Speaker Output:	2.5 Watts min. into 4 ohms
Back Lighting:	28 Volts (standard) or 5 Volts (specify)
Display Colour:	Green (standard) or Red (specify)

DPL is a trademark of Motorola Corporation

## 1.5 TECHNICAL CHARACTERISTICS (continued)

### VHF RECEIVER

Sensitivity at 12 dB SINAD	Better than 0.35 $\mu$ V
Adjacent Channel Selectivity	-75 dB (25 kHz) -70 dB (12.5 kHz)
Spurious Attenuation	-90 dB
Third Order Intermodulation	-70 dB
Image Attenuation	-80 dB
FM Acceptance	$\pm$ 6 KHz
Hum and Noise	Better than 45 dB
Audio Distortion	less than 5%
Antenna Conducted Emission	less than -70 dBm

### UHF RECEIVER

Sensitivity at 12 dB SINAD	Better than 0.35 $\mu$ V
Adjacent Channel Selectivity	-70 dB (25 kHz) -60 dB (12.5 kHz)
Spurious Attenuation	-90 dB
Third Order Intermodulation	-70 dB
Image Attenuation	-60 dB
FM Acceptance	$\pm$ 6 KHz
Hum and Noise	Better than 45 dB
Audio Distortion	less than 5%
Antenna Conducted Emission	less than -70 dBm

### GUARD RECEIVER

All specifications identical to VHF receiver

## VHF and UHF TRANSMITTER

RF Power Output	1 watt or 10 watts
Output Impedance	50 ohms
Maximum Deviation (In narrowband mode)	± 5 kHz (25 kHz mode) ± 2.5 kHz(12.5kHz mode)
Spurious Attenuation	-90 dB below carrier level
Frequency Stability	± 2.5 ppm
Microphone Circuit	Carbon or equivalent
Sidetone Output	0.5W (max) into 600Ω
Harmonic Attenuation	-65 dB below carrier level
FM Hum And Noise	-40 dB
Audio Input	50 mV at 2.5 KHz into 200 Ω input circuit for ± 3.5KHz deviation, adjst.
Audio Distortion	Less than 5%



## SECTION 2

### OPERATING INSTRUCTIONS

#### 2.1 FEATURES

The equipment has several important operating features which provide maximum flexibility, performance and versatility. These features include:

1. VHF and UHF bands that can be configured to be operated independently or as a single unit.
2. The unit can be set up as a crossband repeater, linking a VHF and UHF frequency in both directions.
3. 200 memory positions per band which can each be programmed with a transmit and receive frequency with 25 or 12.5 kHz channel spacing, Tx/Rx CTCSS tones or DPL codes and a 9-character alphanumeric title.
4. 2 guard channels which can each be programmed with a Rx frequency with 25 or 12.5 kHz channel spacing, CTCSS Tx tone or DPL code and a 9-character alphanumeric title.
5. Scanning of preprogrammed memories with selective memory scanning, in 5 scan lists.
6. Priority scan of memory channel 1, if desired.
7. Direct frequency entry mode.
8. Receive frequency simplex function.
9. Switchable RF output power between 1 watt and 8-10 watts.
10. Lockout of keyboard to prevent inadvertent entries.
11. Variable frequency mode to manually scan up and down in 2.5 kHz steps.
12. LED display variable dimming mode.
13. Selectable 90 second Tx time out feature.
14. Quick download of any of the VHF memory positions to the guard memories.
15. PC Memory Upload or Download capability.
16. **Configuration Menu** - Pressing **ENTER**, **RCL** and **FUNC** together while turning the radio on will put it into configuration mode. The programming features affected are:
  - a) **DPL** - Can be turned on or off with the MUP and MDN (4 and 7) keys. This only removes the DPL entry step from the programming sequence and does not stop memories that already have DPL codes from working. This also applies to the rest of the on/off configurable items.
  - b) **Scan** - Can be disabled. Selecting FUNC and SCAN will do nothing if Scan is off. The scan list indicator (+) will still display if was previously programmed.
  - c) **Rx CTCSS** - Can be turned on or off from the programming sequence. This affects only the CTCSS tones for receive.
  - d) **FUNC 7** - Can be turned on or off. When off, the main memory channel can not be dumped into one of the guard channels using function 7.
  - e) **LAST MEM** - If set to on, the last memory channel on the display will be what comes up when the radio is turned on. If set to off, the last memory that changes were made to will be what comes up when the unit is switched on.
  - f) **DUALMODE** - If set to on, the UHF and VHF bands are operated independently and simultaneously. The radio is shipped with this feature OFF.

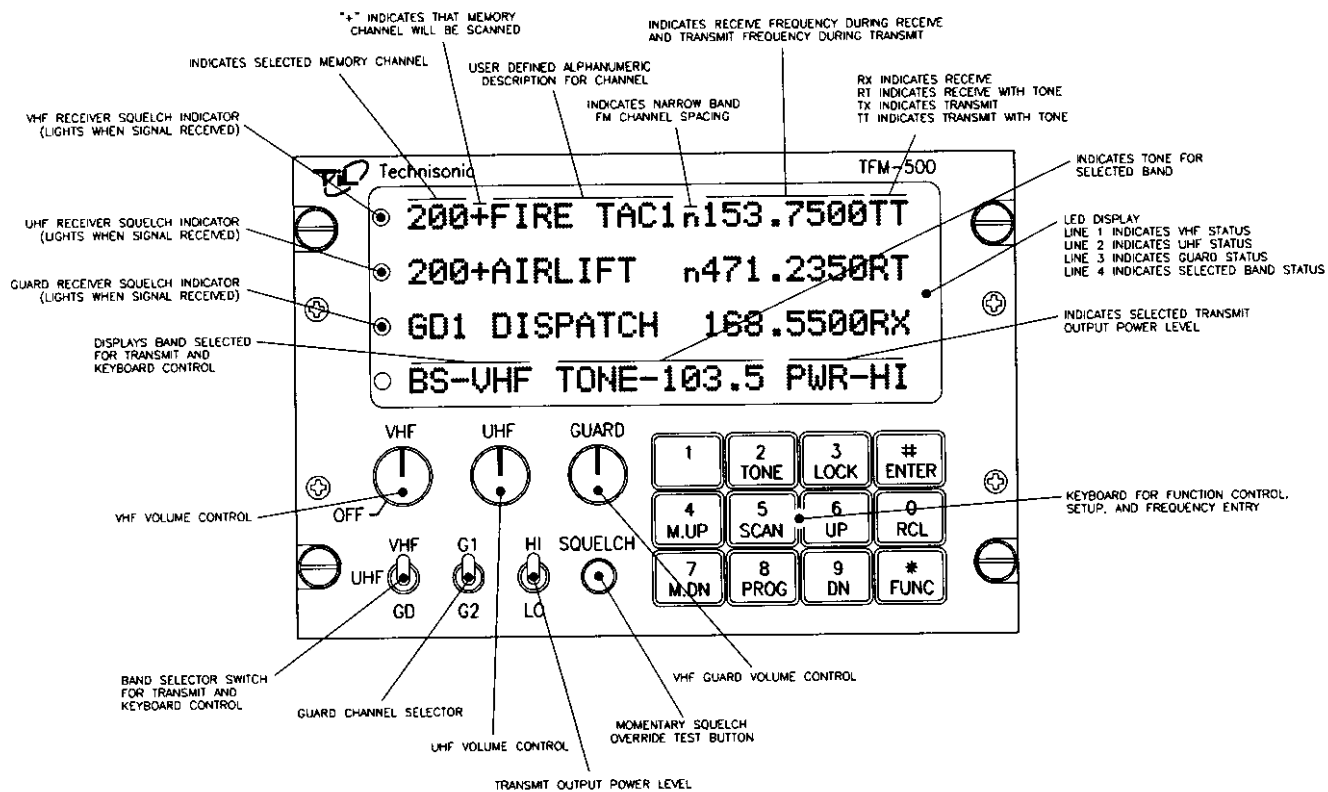

**FIGURE 2-1 Operator's Switches and Controls**

## 2.2 OPERATING INSTRUCTIONS (See Figure 2-1)

1. Switch power on by turning the main volume clockwise. Depending how the radio is configured, either the last programmed or last displayed frequencies will appear on the screen. The transceiver is now in normal operating mode.
2. Adjust the audio level by adjusting the VHF, UHF and GUARD volume knobs.
3. Pressing the squelch defeat button will open all receivers to confirm they work.
4. Read the display. The top line will indicate which VHF memory is selected followed by a "+" if the memory position is included in a scan list, an alphanumeric message, and the frequency of the VHF receiver. A small "n" before the frequency indicates 12.5 kHz narrowband channel spacing is in effect on this memory position. In the receive mode, the frequency is followed by an "RT" if a RX CTCSS tone or RX DPL code is programmed, or an "RX" if no Receive tone/code is programmed. Similarly, in the transmit mode either a "TT" or "TX" is shown after the frequency. The second line shows the same information for the UHF band. The third line indicates information about the guard receiver.
5. Only TX CTCSS tones or TX DPL codes may be programmed for the guard receiver. At the beginning of each line, an LED indicates open squelch.
6. Set the VHF/UHF/GD switch to the desired band.
7. Set the G1/G2 switch to the desired guard channel.
8. Set the HI/LO switch to the desired RF output power.
9. Select the desired memory by using the M.UP and M.DN buttons, or the RCL button and a three digit number followed by ENTER.
10. To transmit DTMF tones, use the keyboard keys while holding the PTT button on the microphone. There is a 5 second PTT delay after pressing a key so that you may press several DTMF keys in sequence without having to hold the PTT. The keyboard returns to its normal function when the PTT is released.

The display always shows the status of both receivers and the transmitter. The light at the left of each line indicates which receiver is receiving. The display also indicates the memory channel in use and the guard channel in use. A "TX" (no TX tone/codes programmed) or "TT" (either TX tone or code programmed) on the right side of the display indicates which band is active when transmitting. The transmit frequency is also shown. In the receive mode the display shows "RX" beside the receive frequency if no RX tone or DPL code is programmed and "RT" if a CTCSS tone or DPL code is programmed.

While in any programming mode, all receivers continue to function.

When the transceiver is in either of the operating frequency or CTCSS tone/DPL code programming modes and you must respond to a call, click the microphone PTT once (the radio will not transmit during this click). This will cause the transceiver to revert back to the normal operating mode and communications with the caller can proceed in the usual fashion.

## 2.3 PROGRAMMING INSTRUCTIONS

To program one of the 200 memory channels in one of the bands:

1. Select the desired band on the band select (VHF/UHF/GD) switch. This is required before any of the programming modes or functions.

2. Press the **FUNC** key. The display will show the function prompt.
3. Press the **PROG** key. The display will show the current receive frequency with a flashing cursor on the first or second digit (The first digit is always a one <1> on the VHF band).
4. Type in the desired receive frequency. If you type in a frequency which is not a 2.5 kHz step, the nearest valid frequency will be automatically selected.
5. The cursor will return to the second digit. You can retype the frequency if you made an error or press **ENTER** to continue.
6. The transmit frequency will be displayed with the cursor on the second digit. Follow the same method as in step 3 and 4.
7. The channel spacing increment of either 25.0 or 12.5 kHz is now displayed. Use the **M.UP** and **M.DN** keys to select the desired channel spacing for the memory position, then press **ENTER**.
8. The alpha-numeric title is now displayed. Use the **M.UP** and **M.DN** keys to scroll through the alphabet, numbers and symbols. When the desired character is displayed, press **ENTER** to advance to the next character. Press "1" to backspace.
9. Keep repeating step six until the last space is set. The display will show SCAN or LOCKOUT to enable this memory position as part of a scan list or lock it out of the scan list. Use the **1,2,3,4,5** and **M.DN** keys to toggle between these functions (for details see paragraph 2.5). Once the desired condition has been selected, press **ENTER**. The TFM-500's display will show a "+" beside the memory channel number if scan is enabled.
10. The display will now show the current memory number. Type in the 3-digit number of the memory you want to save to (if different from displayed one) and press **ENTER**.
11. You now have the option to program the guard frequencies by pressing **FUNC** or press **ENTER** to return to normal operating mode.
11. If you pressed **FUNC** to program the guards, guard"1" transmit frequency will be displayed with the flashing cursor on the second digit. Enter the frequencies for guard"1" receive/transmit and guard"2" receive/transmit as in step 3 and 4.
12. The alphanumeric labels for guard"1" and guard"2" are entered the same as in step 7 and 8. When the last character is entered, the radio returns to normal operating mode.

## 2.4 PRIORITY SCANNING, SELECTIVE MEMORY CHANNEL SCANNING AND SCAN LISTS

Instead of breaking up the 200 channels into blocks for scanning, the TFM-500 has 5 scan lists per band. Any of the 200 channels can be assigned to any one or more of these 5 scan lists. This means the channels do not have to be repeated for them to be in more than one block and that you are not limited to the number of channels that you can scan at once, since all 200 channels can be put into any scan list.

The priority memory channel is always memory position number 1. The priority memory channel is scanned every other step (ie. 121314151...) to ensure that no incoming messages are missed. The priority channel can be locked out, which will result in the normal scanning of the other memory positions.

Selective memory scanning allows the user to select which of the 200 memory channels are to be scanned or locked out when the scan function is invoked. To use this feature, follow the PROGRAMMING INSTRUCTIONS found in paragraph 2.3. Once the screen displays **SCAN** or **LOCKOUT**, use the **1,2,3,4,5** or **M.DN** keys to toggle to the desired condition and press **ENTER**. Entering the any or all of the numbers 1,2,3,4 or 5 will include that memory channel in any of the five scan lists. In normal operating mode the display will later show a "+" beside the memory channel number if it has been included in any of the 5 scan lists.

## 2.5 SCANNING FUNCTION (5 second talkback delay)

Select the band you wish to scan with the band switch. (you can not scan the guard)

To start scanning of the memory channels, press **FUNC** then **SCAN** and then the number (1,2,3,4,5) of the desired scan list.

The radio will scan through all the preset memory positions in the selected scan list (see above paragraph for priority and selective scan features) and will lock on to the first active channel in the scan sequence. It will remain on the channel until it becomes inactive. Scanning will resume again after five seconds of inactivity. To exit the scan mode, press the **SCAN** key. This will cause the radio to revert back to the normal operating mode.

If while scanning, you hear a call for you:

1. Respond to the call within 5 seconds. When scanning is interrupted by an incoming signal, the channel will remain open for five seconds before resuming scanning.
2. During communications the five second timer is reset from the last Rx or Tx signal encountered.

The radio resumes scanning once the Rx or Tx activity has ceased for more than five seconds. The **SCAN** key must be pressed to exit the scan mode.

## 2.6 DIRECT FREQUENCY ENTRY MODE

This mode is designed to facilitate quick frequency selection during emergency and other operational conditions requiring direct operating frequency selection. This operating mode is disabled along with the programming mode when the internal disable jumper is set.

1. When the transceiver is in the normal operating mode, press **FUNC** and the desired operating frequency ie/ 153.2750.
2. On the UHF band press **FUNC** and then **1** and the desired frequency ie/ 443.5500.
3. You will then be asked for 12.5 or 25.0 kHz channel spacing. Select with **MUP** or **MDN** and press **ENTER**.

Please note in the above operation, after **FUNC** and "**1**" are entered, the LED display will show memory channel "000" and then the remaining digits in the desired frequency are shown as they are entered. No alphanumeric message can be entered in this mode. Operation on the new frequency occurs in both transmit and receive (simplex only) modes. If RX or TX CTCSS tones/DPL codes are required they must be programmed in afterwards.

## 2.7 RECEIVE FREQUENCY SIMPLEX FUNCTION

The receive frequency simplex function allows you to quickly change the transmit frequency, when operating on a split pair (repeater/semi-duplex mode), to the receive frequency to allow direct communications. ie/ If you are transmitting on 152.000 MHz and receiving 152.555 MHz, select **VHF** on the band select switch and press **FUNC** then **UP** to transmit on 152.555 MHz. To return to the split pair condition, you must recall the memory channel again. This is quickly done by pressing **M.UP** for one step up, then back down one step with the **M.DN** key.

## 2.8 KEYBOARD LOCKOUT FUNCTION

The keyboard can be locked out so that accidental pressing of keys does not change frequency, etc., unknowingly to the operator. To lock the keyboard, press **FUNC** then **LOCK**. This will disable all keyboard functions (except keyboard unlock) in the receive mode. The DTMF function during transmit will not be affected. To unlock the keyboard, press and hold the **LOCK** key for two seconds until the display indicates "UNLOCK".

## 2.9 VARIABLE FREQUENCY MODE FUNCTION

To enter variable frequency mode, press **RCL, 0,0,0**, then **ENTER** or enter a frequency in the direct entry mode described above. The memory channel that you were just in will still be valid but now you can manually adjust the frequency with the **M.UP**, **M.DN**, **UP** and **DN** keys. The **UP** and **DN** keys will make the frequency count up or down in steps of 2.5 kHz. The **M.UP** and **M.DN** keys will make the frequency count up or down in steps of 1 MHz. You can not change the label. The frequency in this mode can not be stored in memory. To exit this mode, recall one of the 200 memory channels (ie. **RCL, 0,0,1**). Variable frequency mode is disabled when the internal entry disable jumper is set.

## 2.10 LED DISPLAY VARIABLE DIMMING MODE

1. With the transceiver in normal operating mode press the **UP** or **DN** keys to increase or decrease the intensity of the LED display.
2. Once maximum intensity of the display is achieved, the **UP** key no longer functions. Conversely once minimum intensity is reached, the **DN** key ceases to function.

## 2.11 90 SECOND TRANSMITTER TIME OUT FEATURE

A selectable 90 second transmitter time out feature is provided to prevent accidental continuous transmission in the event of a faulty PTT switch. With this feature enabled the transceiver will stop transmitting after the PTT is engaged continuously for 90 seconds. The timer is reset by releasing then re-engaging the PTT switch. Press the **FUNC** then the **M.UP** key. Use the **M.UP** and **M.DN** keys to select 90 SEC, which enables the feature, or NONE which disables it.

## 2.12 QUICK GUARD PROGRAMMING FEATURE

A quick download of any of the 200 VHF memory positions into either of the guard memory positions can be accomplished. Select the memory position whose contents you desire to download to a guard memory. Select either GD1 or GD2 memory channel as desired. Press **FUNC** then **7**. The guard memory channel will now contain all the same information as the selected memory position. This feature is disabled when the FUNC 7 mode is turned off in the configuration menu.

## 2.13 PROGRAMMING CTCSS TONES/DPL CODES

CTCSS tones (PL tones) or Digital DPL codes can be assigned to each memory channel. The guard receiver squelch will operate on noise squelch only, but guard 1 and 2 transmit tones or codes can be programmed. To program a tone/code to a memory channel:

1. Select the desired band on the band select switch.
2. Use the **M.UP** and **M.DN** keys to select the memory channel that you want to assign a CTCSS tone or DPL code.

3. Press the **FUNC** key then the **TONE** key. The display will show "RX TONE:" and the current tone number, as well as the tone frequency in Hz.
4. Use the **M.UP** and **M.DN** keys to select the tone number you require. The following is a list of the available CTCSS tones:

<u>Number</u>	<u>Tone</u>	<u>Number</u>	<u>Tone</u>	<u>Number</u>	<u>Tone</u>
01	67.0	26	162.2	51	177.3*
02	71.9	27	167.9	52	183.5*
03	74.4	28	173.8	53	189.9*
04	77.0	29	179.9	54	196.6*
05	79.7	30	186.2	55	199.5*
06	82.5	31	192.8	56	206.5*
07	85.4	32	203.5	57	210.7*
08	88.5	33	33.0*	58	218.1*
09	91.5	34	35.4*	59	225.7*
10	94.8	35	36.6*	60	229.1*
11	97.4	36	37.9*	61	233.6*
12	100.0	37	39.6*	62	241.8*
13	103.5	38	44.4*	63	250.3*
14	107.2	39	47.5*	64	No Tone
15	110.9	40	49.2*		(carrier squelch only)
16	114.8	41	51.2*		(The tones marked with * are nonstandard tones).
17	118.8	42	53.0*		
18	123.0	43	54.9*		
19	127.3	44	56.8*		
20	131.8	45	58.8*		
21	136.5	46	63.0*		
22	141.3	47	69.4*		
23	146.2	48	159.8*		
24	151.4	49	165.5*		
25	156.7	50	171.3*		

4. Press ENTER. "TX TONE" appears on the display. Repeat step 3.
5. Press ENTER. "G1 TONE" appears on the display. Repeat step 3.
6. Press ENTER. "G2 TONE" appears on the display. Repeat step 3 and press ENTER.
7. The display will now show "RX DPL:" and the current 3-digit DPL code. If no DPL code is required "000" should be entered. Please note that if a DPL code is to be programmed a CTCSS tone should not be enabled.
8. Use the keypad to enter the required octal 3-digit DPL (Digital Coded Squelch or DCS) code. A list of all usable and unique octal 3-digit DPL/DCS codes follows:

017*	051	116	156	243	266*	346	431	466	612	721
023	053*	122*	162	244	271	351	432	503	624	731
025	054	125	165	245	274*	356*	445	506	627	732
026	065	131	172	246*	306	364	446*	516	631	734
031	071	132	174	251	311	365	452*	523*	632	743
032	072	134	205	252*	315	371	454*	526*	654	754
036*	073	143	212*	255*	325*	411	455*	532	662	
043	074	145*	223	261	331	412	462*	546	664	
047	114	152	225*	263	332*	413	464	565	703	
050*	115	155	226	265	343	423	465	606	712	

\* indicates GE Digital Coded Squelch (DCS) Code

9. Press ENTER. "TX DPL" appears on the display. Repeat step 8.
10. Press ENTER. "G1 DPL" appears on the display. Repeat step 8.
11. Press ENTER. "G2 DPL" appears on the display. Repeat step 8 and press ENTER.

## 2.14 PC MEMORY PROGRAMMING UP/DOWNLOAD CAPABILITY

The TFM-500 transceiver can be programmed by a MS-DOS based personal computer. This is an alternative to programming data manually by the keypad. The programmed information can also be removed from the TFM-500 and stored in a PC. There are two ways to download or upload from the TFM-500. One method is to use a terminal program such as is supplied with MS Windows 3.1, 95, 98, and NT. The other method is to use Technisonic software. A 3.5" disk containing the required PC up/download software is provided with each TFM-500 transceiver. To use the supplied software follow the instructions below:

### Requirements:

1. PC compatible computer with any monitor, 3.5" floppy drive and a serial port.
2. Bench power supply of 28 volts DC.
3. PC download cable, P/N 98xxxx-x which can be supplied or made from the wiring diagram at the back of this section.

### Installation:

1. Insert the floppy disk into drive A and type: A:INSTALL <enter>
2. All the files will be copied to your hard drive into a directory called \TIL.

### Connections:

1. With the PC turned off, plug the 25 pin male 'D' connector into its serial port.
2. Plug the 9 pin 'D' connector into the back of the TFM-500 transceiver.
3. Plug the 25 pin 'D' connector into the back of the radio and connect the power wires to the power supply.

### Running the program:

1. Turn on the power supply and the TFM-500 unit first and then turn on the PC.



2. Change to the \TIL directory and type: PCDLxxx and <enter>. The main menu will be displayed.

### **Listing memory channels:**

The first channel listed (in blue on colour monitors) is the memory channel that will appear on the display of the TFM-500 unit when it is turned on. The next two channels listed are guard 1 and guard 2. (in red on colour monitors) Only TX CTCSS tones or TX DPL codes are listed for the guards since the TFM-500 unit has a CTCSS tone/DPL code decoder for the main receiver only. The rest of the memory channels displayed (in yellow) are the 200 memories in each band listed in sequence. Either LOCK or SCAN LIST numbers "1,2,3,4,5" are displayed for each memory channel which indicates whether that memory channel will be included in any of the 5 scan lists or locked out. After the scan information, an "N" or blank space will follow to indicate narrowband or wideband mode respectively. After reviewing the multi-page list, you have the option to return to the first page, for further review or to return to the main menu.

### **Printing Memory Channels:**

To print out a listing of the memory channel database, select 'P' from the main menu. You will be prompted for a title that will appear on the listing. This could be for example the serial number of the radio. Press <enter> and the printing will start. The main menu will appear when printing is complete.

### **Edit menu:**

You can select which memory channel to program, main or guard. When entering memory channel information, if you just press return, the previous information will be retained. For example, you only want to change the receive frequency. Type in the new receive frequency and press return for all of the other prompts. You also will not be able to type in frequencies or information that does not make sense. If the information entered is not what was prompted for, you will be re-prompted for the correct information. For example, if you type in 999.9999 for the transmit frequency you will be prompted again because the frequency range of the TFM-500 product is 138 to 174 MHz and 403 to 512 MHz. Keep in mind that the label for the memory channel can only have characters that exist on the TFM-500 unit. These include only capital letters, numbers 0 to 9 and a few other characters. Any other character will show up as a blank on the unit's display. If you type in lowercase letters they will automatically be converted into capital letters when you download to the radio.

You will then be prompted to enter a receive CTCSS tone, a transmit CTCSS tone, a receive DPL code and a transmit DPL code. Although both CTCSS tones and DPL codes can be programmed simultaneously, this should not be done. Care should also be taken to program the correct DPL code since non-unique (inverted) code numbers will be accepted.

### **Downloading to the Transceiver:**

Select 'D' from the main menu. Follow on screen instructions. The memory channels will be downloaded sequentially to the TFM-500 unit. You will be able to see them on the radio's display as they go by. The download process will take less than one minute. (The data transfer is fast but the nonvolatile memory in the radio needs time to program.) The PC will return to the main menu when the process is complete. The radio will also return to the normal operating mode when done.

Selecting 'O' from the main menu will enable you to download a single memory to the radio. You will be prompted for the originating memory number (in the database), then the destination memory number (in the radio). This makes it possible to place data into radios that have different channel listings and not load a memory on top of one that was still desired. Follow on screen instructions to complete download.

**Uploading From the TFM-500:**

Uploading from the radio is started by selecting 'U' in the main menu. Follow on screen instructions. The upload should take about 10 seconds depending on the speed of the PC. The previous data base will be replaced by the contents of the radio. If the previous database is still needed, the file 'DATA500' should be copied to another file name in DOS before the upload is attempted.

**Files:**

The file containing the memory channel list is named 'DATA500' in the \TIL directory. The program will not run if it can not find the 'DATA500' file. To have multiple databases, you can copy the data file to a new name and edit the 'DATA500' file again. To retrieve a database, copy it back to 'DATA500'.

TFM-500 Upload/Download Programming Cable  
P/N 98xxxx-x - Wiring Diagram

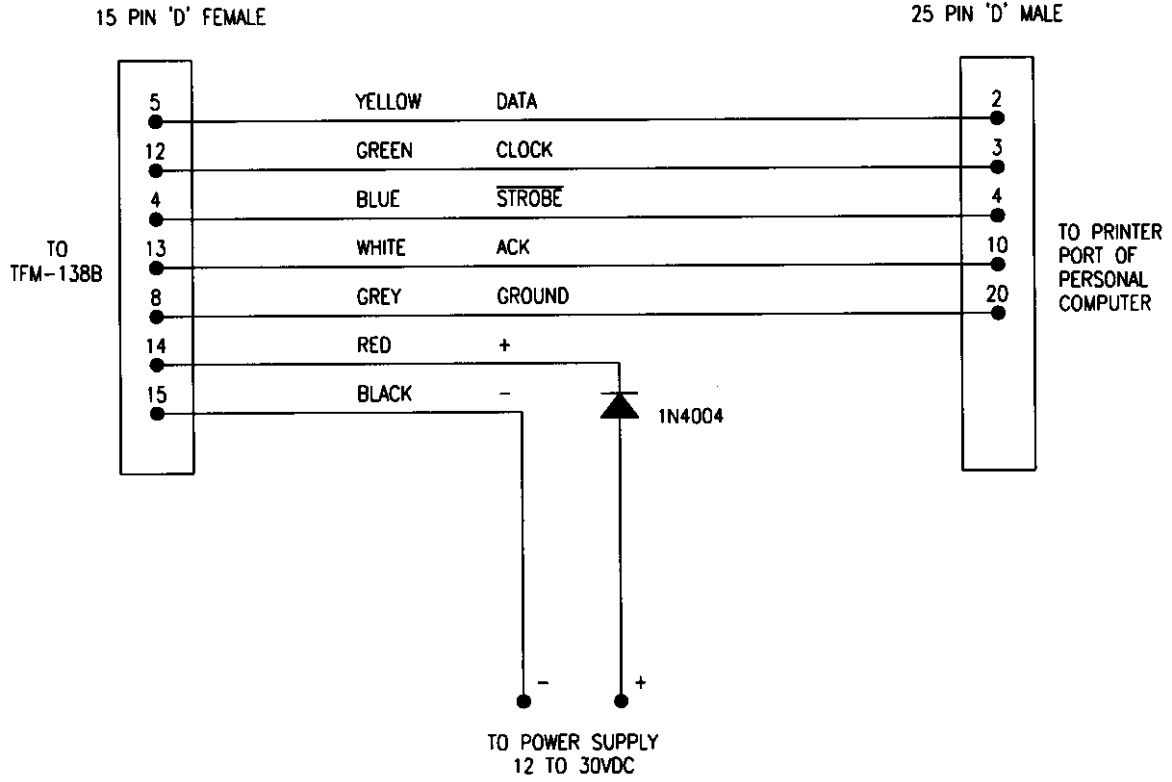

944032B

**FIGURE 2-2 TFM-500 Transceiver PC Up/Download Cable - wiring diagram**

## SECTION 3

### INSTALLATION INSTRUCTIONS

#### 3.1 GENERAL

This section contains information and instructions for the correct installation of the TFM-500, VHF/FM Transceiver.

Make certain that the correct frequencies are preprogrammed in accordance with the equipment user's valid FCC operator's license, prior to installation.

#### 3.2 EQUIPMENT PACKING LOG

Unpack the equipment and check for any damage that may have occurred during transit. Save the original shipping container for returns due to damage or warranty claims. Check that each item on the packing slip has been shipped in the container. Verify that the equipment display and backlighting configuration are the same as those ordered.

#### 3.3 TRANSCEIVER INSTALLATION

The TFM-500 transceiver is designed to be Dzus mounted and should be installed in conjunction with a IN-xxx installation kit. See Figure 3-1 for an outline drawing of the unit with dimensions to facilitate the installation.

#### 3.4 INSTALLATION KIT - CONTENTS

The IN-xxx installation kit consists of:

1. One 15 pin Cannon D mating connector (female) complete with crimp pins and hood.
2. One 9 pin Cannon D mating connector (male) complete with crimp pins and hood.
2. Two BNC antenna mating RF connectors (male).

#### 3.5 ANTENNA INSTALLATION

Antenna, P/N's ATM-150 and ATM-403 may be obtained from Technisonic Industries Limited or a suitable equivalent may be utilized with the TFM-500 transceiver. The antenna should be mounted on the bottom of the aircraft whenever possible. Consult with instructions provided with the antennas. Connect RF cables from antennas to the back of the TFM-500 unit by utilizing the BNC mating connector provided in the installation kit. The UHF connector is located on the rear, above the 15-pin D connector and the VHF connector is below the 9-pin D.

#### 3.6 INSTALLATION - PIN LOCATIONS AND CONNECTIONS

The pin numbers and locations for the 15 pin and 9 pin Cannon D located on the rear of the TFM-500 transceiver are shown below. Pin connections are in provided in TABLE 3-1.



Transceiver mounted view of 15 pin and 9 pin connector

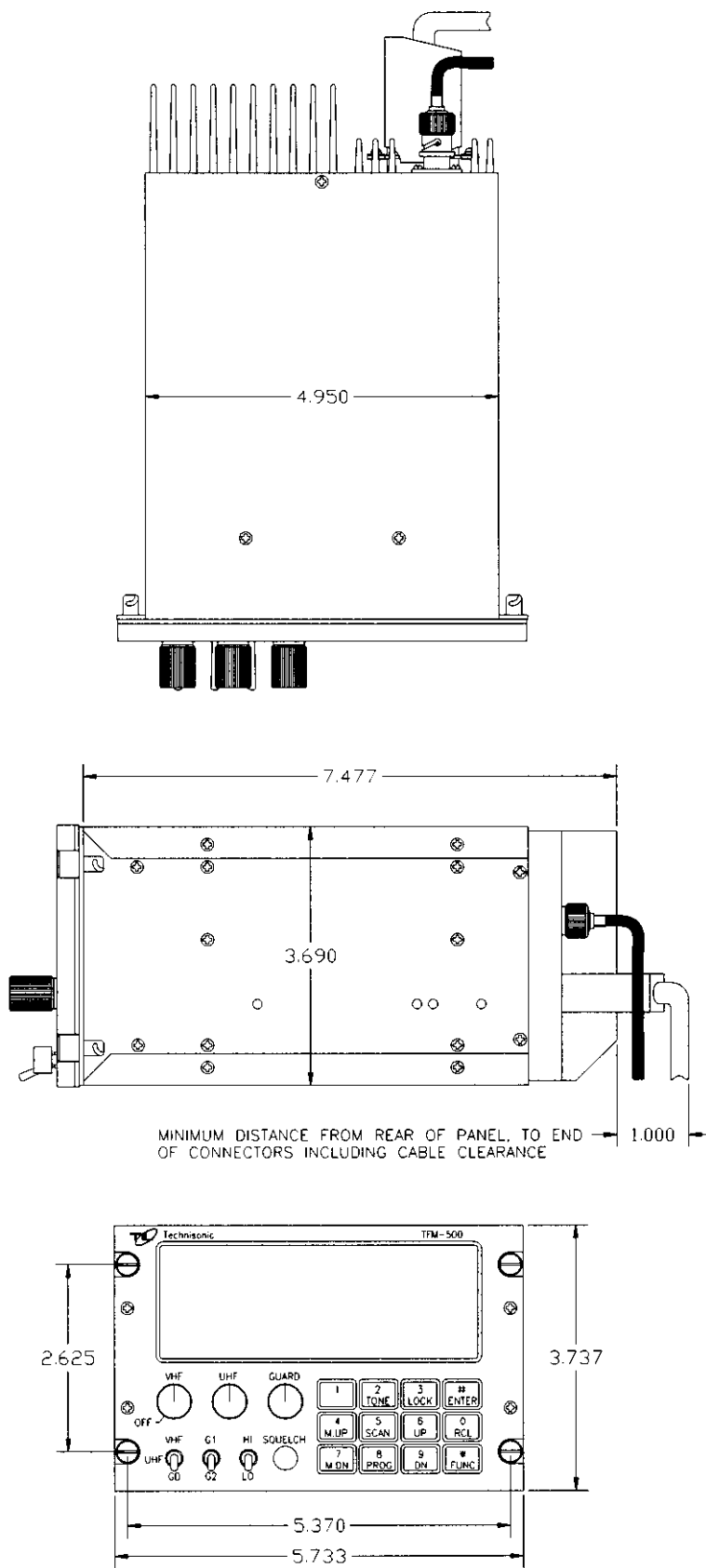

**FIGURE 3-1 Outline Drawing for Model TFM-500 Transceiver**

3.6 INSTALLATION - PIN LOCATIONS AND CONNECTIONS (continued)

15 Pin D Connections	
<u>Pin #</u>	<u>Description</u>
1	600 Ohm Output 1
2	Data Output
3	Panel Lighting (28VDC or 5VAC)
4	Memory UP/PC Download Input
5	Memory Down/PC Download Input
6	Mic Signal Input 1
7	Main Power +28VDC
8	Main Ground
9	4 ohm Speaker Output
10	4 ohm/600 ohm Output Ground
11	Data Input
12	PC Download Input
13	PTT 1 (Ground Keying)
14	Main Power +28VDC
15	Main Ground

9 Pin D Connections	
<u>Pin #</u>	<u>Description</u>
1	Ground
2	Background Debug Signal
3	Reset
4	PTT 2 (Ground Keying)
5	600 ohm Output 2
6	Mic Signal Input 2
7	Serial Data In
8	Serial Data Out
9	Programming Voltage In

TABLE 3-1

### **3.7 WIRING INSTRUCTIONS**

Figure 3-2 shows all required connections and recommended wire sizes for the TFM-500 Transceiver.

#### **3.7.1 Main Power +28VDC**

The main power +28VDC ( $\pm 15\%$ ) is connected to pins 7 and 14 of the transceiver. Both pins should be connected.

#### **3.7.2 Main Ground**

Ground connections for the transceiver are made on pins 8 and 15. Both pins should be connected.

#### **3.7.3 PTT 1 (Ground Keying)**

The PTT line is connected to pin 13 and should be floating when the transceiver is in receive mode, and grounded during transmit mode.

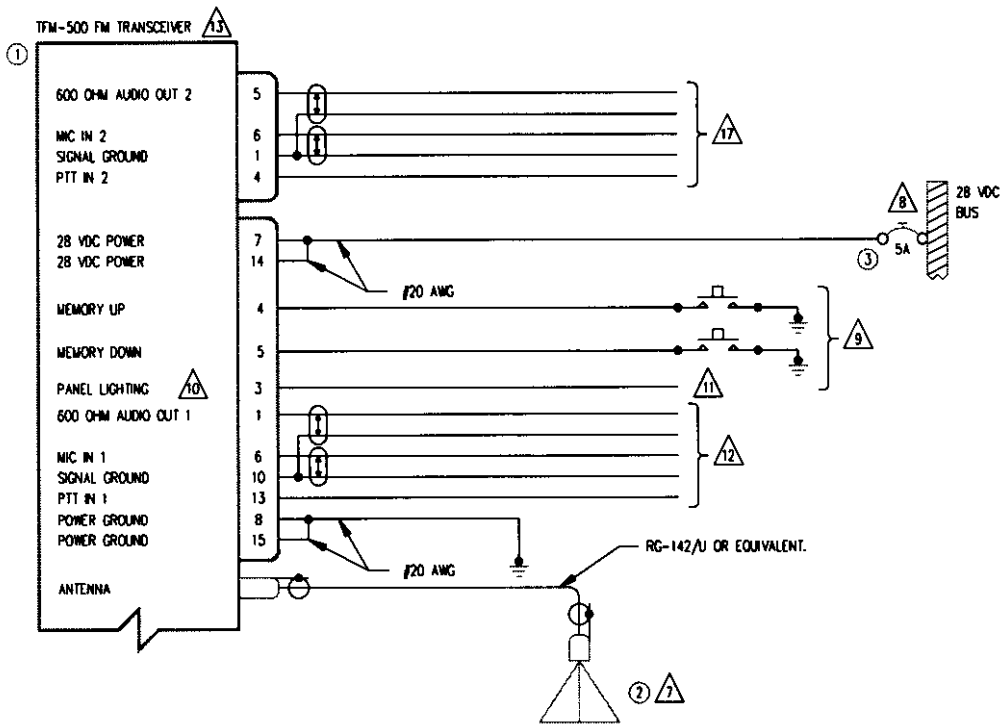

QTY	ITEM	PART NUMBER	DESCRIPTION	SPEC	MATERIAL
1	1	TFM-500	VHF/FM COMMUNICATIONS TRANSCEIVER.	TECHNISONIC INDUSTRIES LIMITED	
1	2	AT-150	ANTENNA - VHF	TECHNISONIC INDUSTRIES LIMITED	
1	3	7274-11-5	CIRCUIT BREAKER, 5 AMPS	KLIXON	
1	4	AT-403	ANTENNA - UHF	TECHNISONIC INDUSTRIES LIMITED	

NOTES:

- 1) ALL WIRE IAW MIL-W-22759 UNLESS OTHERWISE SPECIFIED.
- 2) ALL CABLE IAW MIL-C-27500 UNLESS OTHERWISE SPECIFIED.
- 3) COAXIAL CABLE IAW MIL-C-17 UNLESS OTHERWISE SPECIFIED. DO NOT USE COAX WITH PVC INSULATION.
- 4) FABRICATION & INSTALLATION OF WIRING HARNESS IAW AC 43.13-1A CHAPTER 11, SECTION 3, PARA 445 TO 462 AND SECTION 7.
- 5) GROUNDING AND BONDING IAW AC 43.13-1A CHAPTER 11, SECTION 3, PARA 452.
- 6) ALL SINGLE WIRE TO BE #22 AWG MINIMUM AND ALL SHIELDED WIRE TO BE #24 AWG MINIMUM, UNLESS OTHERWISE SPECIFIED.
- 7) INSTALLATION OF ANTENNA IAW AC 43.13-1A CHAPTER 2, SECTION 3, CHAPTERS 5 & 6, AND AC 43.13-2A CHAPTER 3. IF POSSIBLE, THE ANTENNA SHOULD BE LOCATED A MINIMUM OF 12 FT FROM AIRCRAFT NAVIGATION RECEIVER ANTENNAS AND A MINIMUM OF 4 FEET FROM AIRCRAFT COMMUNICATIONS AND ELT ANTENNAS. BE CAREFUL NOT TO CHOSE SEPARATIONS THAT CLOSELY APPROXIMATE 1/4 OR 1/2 OR WHOLE NUMBER MULTIPLES OF THE NAVIGATION OR COMMUNICATIONS SYSTEM WAVELENGTH.
- 8) AN EQUIVALENT CIRCUIT BREAKER OR FUSE MAY BE USED.
- 9) THE MEMORY UP/DOWN PUSH BUTTONS ARE OPTIONAL.
- 10) THE TFM-500 IS AVAILABLE WITH 28V OR 5V PANEL LIGHTING. CHECK THE CONFIGURATION CONTROL LABEL FOR THE CORRECT VOLTAGE.
- 11) CONNECT TO THE APPROPRIATE AIRCRAFT DIMMING BUSS.
- 12) CONNECT TO THE AIRCRAFT AUDIO SYSTEM OR STAND-ALONE HEADSET JACKS.
- 13) INSTALLATION OF TRANSCEIVER IAW AC 43.13-1A CHAPTER 2, SECTION 3 AND AC 43.13-2A, CHAPTER 2. PR 3 1/2 DZUS RAIL OR EQUIVALENT MAY BE USED.
- 14) TEST THE SYSTEM IN ACCORDANCE WITH THE POST-INSTALLATION TEST PROCEDURE IN THE INSTALLATION AND OPERATING INSTRUCTIONS MANUAL.
- 15) REFER TO THE AIRCRAFT STRUCTURAL REPAIR MANUAL AND THE MAINTENANCE MANUAL FOR INSTRUCTIONS AND INFORMATION PERTINENT TO THIS INSTALLATION.
- 16) THE USE OF RED DISPLAYS SHOULD BE MINIMIZED OR AVOIDED SO AS NOT TO DETRACT FROM THE ATTENTION GETTING CHARACTERISTICS NEEDED IN WARNING AND CAUTION ANNUNCIATORS. RED SHOULD BE USED TO ANNUNCIATE EMERGENCY CONDITIONS REQUIRING IMMEDIATE RESPONSE BY THE FLIGHT CREW. UNITS WITH RED DISPLAYS SHOULD NOT BE LOCATED IN CLOSE PROXIMITY TO WARNING AND CAUTION ANNUNCIATORS. THE INSTALLATION OF UNITS WITH RED DISPLAYS MUST BE EVALUATED ON A CASE BY CASE BASIS TO ENSURE THAT THE EFFECTIVENESS OF THE WARNING AND CAUTION ANNUNCIATORS IS NOT ADVERSELY AFFECTED.
- 17) ONLY USED IF THE TRANSCEIVER WILL BE OPERATED IN DUAL MODE. (OPERATION OF 2 BANDS INDEPENDENTLY)

FIGURE 3-2 Wiring connections for the TFM-500 Transceiver



### **3.7.4 Front Panel Back Lighting**

Front panel back lighting connection should be made on pin 3 of the transceiver. The opposite end of this lead should be connected to the panel lighting system of the aircraft. Before connecting, verify the required panel lighting voltage (28 VDC or 5VAC) on the transceiver configuration control label.

### **3.7.5 Audio Outputs (600 ohms and 4 Ohms)**

There are two audio outputs available (1 & 2). 600 ohm audio output 1 has audio from both bands and the guard in single operator mode. When in dual operator mode, 600 ohm output 1 has audio from the VHF band and guard only while the UHF audio will be on the 600 ohm output 2.

### **3.7.6 Audio Output Ground**

Pin 10 is the ground for both the 4 ohm and 600 ohm audio output signals.

### **3.7.7 Mic Signal Input**

The microphone input signal is to be provided on pin 6, utilizing shielded wire with the shield grounded to pin 10. Microphone signal 2 is on pin 6 of the 9-pin D connector.

### **3.7.8 Memory Up/Memory Down**

Remote scrolling through the 200 memory positions can be achieved by providing a ground to pins 4 (up) and 5 (down) through a momentary contact cyclic switch. The memories will scroll only on the band selected.

### **3.7.9 Data Input**

Data communications equipment requiring direct access to the modulator and discriminator can be connected via pins 2 and 11. Data cannot be transmitted in CANADA unless equipment is approved for use with the TFM-500 by the communications regulatory authority.

## **3.8 INTERNAL PROGRAMMING AND GUARD ENABLE/DISABLE JUMPER**

The programming and direct frequency entry modes can be disabled by removing the internal enable/disable jumper strap from pins 1 and 2 of J10. Removal of this jumper will prevent operation on any frequencies other than those programmed in the 400 memory positions and two guard receiver memory positions. Removal of the guard receiver programming enable /disable jumper strap from pins 1 and 2 of J11 will totally disable the operator's ability to re-program the 2 guard receiver channels.

The transceiver is always shipped with the two jumpers in the entry enable positions. To place either of the jumpers in the disable position:

1. Remove the top cover of the radio.
2. Remove both the left and the right sides.
3. Unplug the white coax from the guard receiver board.
4. Remove front panel.
5. Remove the guard tray.
6. Remove the antenna filter cover and desolder the antenna connector wire.
7. Remove the UHF module.
8. Set or remove jumpers as necessary.
9. Re-assemble the radio in reverse order.

# Microprocessor Control Unit (MCU) PCB Module

Notes: R23 is High Power Adjustment  
R24 is Low Power Adjustment  
J15 Jumper between pins 3 and 4 for Entry Enable  
Remove for Entry Disable

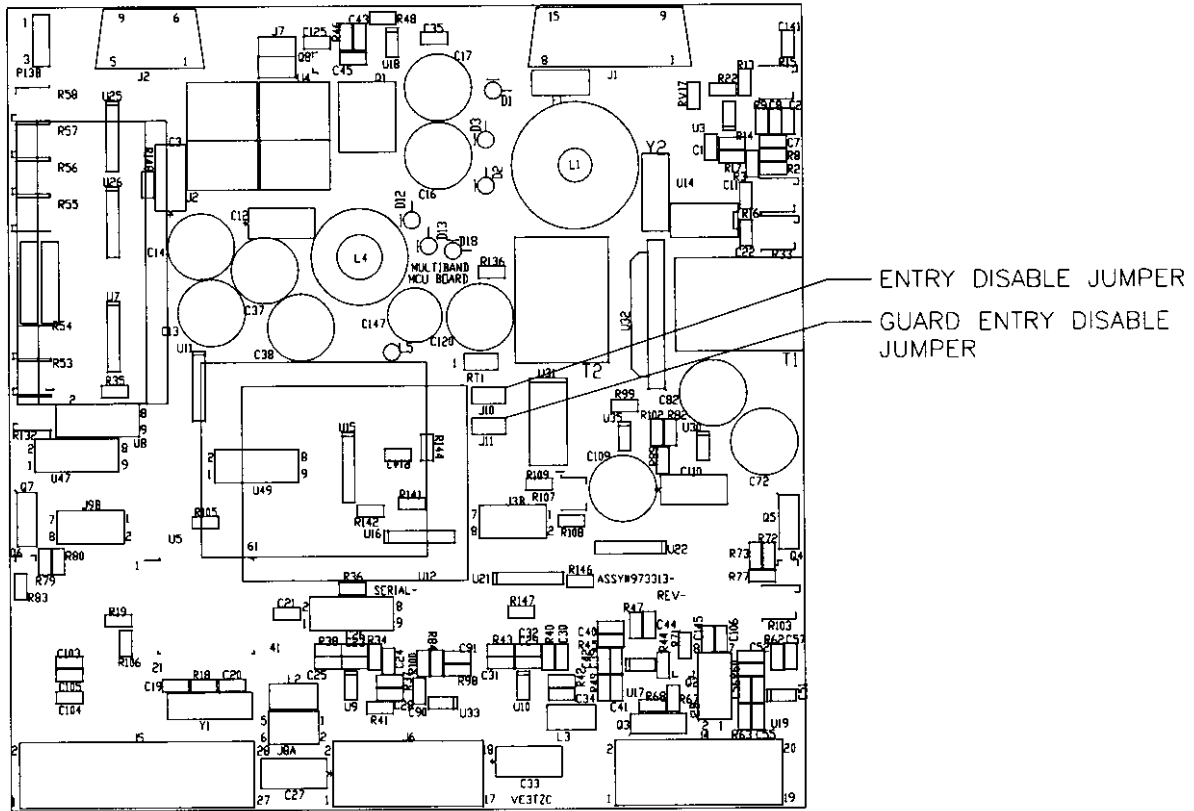

FIGURE 3-3 Internal Enable/Disable Jumper Locations

### **3.9 TRANSMITTER POWER ADJUSTMENTS**

The transmitter power is adjusted to a maximum of 10 watts in high power mode and 1 watt in low power mode over the transceiver operating bandwidth at the factory. If transmitter RF power re-adjustment is required, perform as follows:

1. Select the band that you wish to adjust on the band select switch.
2. Connect an RF through-line wattmeter to the appropriate antenna connector. Set the operating frequency to 156.000 MHz for VHF or 457.000 MHz for UHF and key the transmitter.
3. In low power mode, set the low power adjustment potentiometer on the left side of the chassis to produce 1.0 watt of RF output power (See Figure 3-3).
4. In high power mode, set high power adjustment potentiometer on the left side of the chassis to produce 9.5 watts of RF output power.
5. Verify that the RF output power is between 9 and 10 watts on 138.000 MHz and 174.000 MHz for VHF or 403.000 MHz and 512.000 MHz for UHF.

### **3.10 TRANSMITTER MICROPHONE LEVEL ADJUSTMENT**

1. Set the transceiver operating frequency to 156.000 MHz and connect an appropriate test receiver to the RF output connector. Ensure that the output of the transceiver is terminated into a proper dummy load.
2. Key the transmitter and input a -10 dBm (0.25 VRMS), 1 kHz audio signal into the microphone input.
3. Adjust the microphone level potentiometer (Mic Level 1) through the access hole located on the right side of the chassis (see Figure 3-4) to produce a 3.5 kHz deviation.
4. Verify that the deviation is at least 3 kHz on the following frequencies: 138.000 MHz, 162.000 MHz and 174.000 MHz.
- 5.

### **3.11 TRANSMITTER SIDETONE LEVEL ADJUSTMENT**

1. Set the transceiver operating frequency to 156.000 MHz and connect an appropriate test receiver to the RF output connector. Ensure that the output of the transceiver is terminated into a proper dummy load.
2. Key the transmitter and input a -10 dBm (0.25 VRMS), 1 kHz audio signal into the microphone input.
3. Adjust the sidetone level potentiometer (R37 on MCU module) through the access hole located on the left side of the chassis (see Figure 3-4) to produce a +3.0 dBm (1.0 VRMS) 600 ohm audio output.

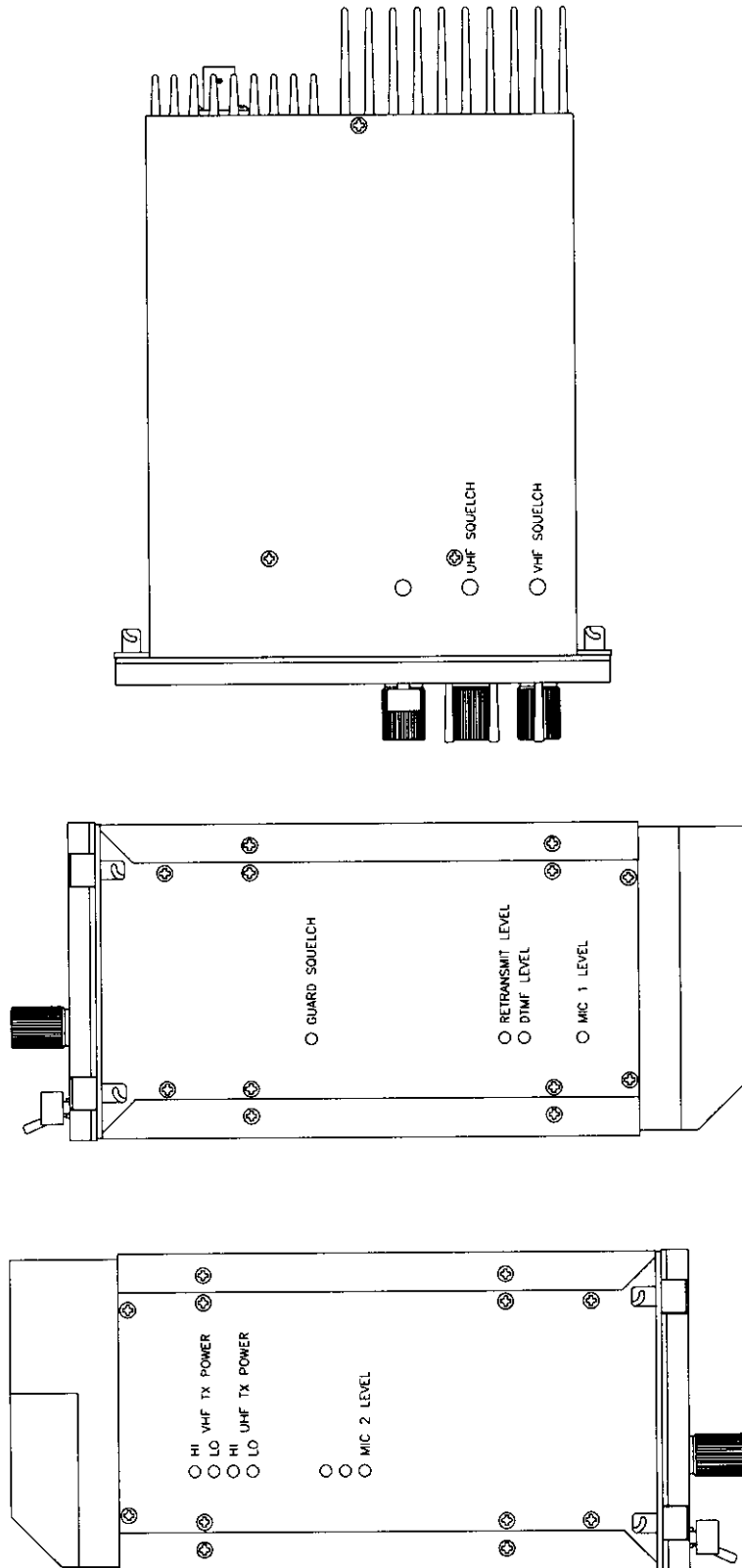

**FIGURE 3-4 External Adjustment Access Holes**

### 3.12 SQUELCH ADJUSTMENT

The squelch on both the main and guard receivers is factory set to open at approximately 1.0 microvolt. This adjustment can be made or altered to suit local conditions as follows:

1. Set the receiver to 157.000 MHz for VHF or 457.000 MHz for UHF. Connect a signal generator to the antenna input of the desired band.
2. Set the signal generator to produce a  $\pm 3$  kHz deviation with a 1 kHz tone on 157.000 MHz or 457.000 MHz. Increase the signal generator RF level from 0.1  $\mu$ V until the squelch indicator LED is on. Verify the squelch opens at the desired level.
3. If not, re-adjust receiver squelch potentiometer through the access hole located on the bottom or side of the transceiver chassis (see Figure 3-4).

### 3.13 TRANSMITTER DEVIATION ADJUSTMENT

#### VHF:

1. Remove the bottom cover of the transceiver.
2. Set the VHF operating frequency to 157.000 MHz and connect an appropriate test receiver to the RF output connector. Ensure that the output of the transceiver is terminated into a proper dummy load.
3. Key the transmitter and input a +10 dBm (2.5 VRMS), 1 kHz audio signal into microphone input 1.
4. Adjust the wideband deviation limit potentiometer, R30 on the VHF Rx/Tx module (see Figure 3-5) to produce a  $\pm 4.25$  kHz deviation. Select narrow band mode on the VHF band and adjust the narrowband deviation limit potentiometer, R76 on the VHF Rx/Tx module to produce a  $\pm 2.15$  kHz deviation.
5. Verify that the deviation does not exceed  $\pm 5$  kHz for wideband and  $\pm 2.5$  kHz for narrowband on 138.000 MHz, and 174.000 MHz. Re-adjust R30 or R76 as required, if the deviation exceeds  $\pm 5$  kHz or  $\pm 2.5$  kHz, respectively.
6. Replace the bottom cover.

#### UHF:

1. Remove the top cover of the transceiver.
2. Unplug the white coax from the guard receiver and remove the front panel.
3. Remove the guard receiver tray.
4. Replace the front panel and select the UHF band.
5. Set the UHF operating frequency to 457.000 MHz and connect an appropriate test receiver to the RF output connector. Ensure that the output of the transceiver is terminated into a proper dummy load.
6. Key the transmitter and input a +10 dBm (2.5 VRMS), 1 kHz audio signal into microphone input 1 if in single mode or microphone input 2 if in dual mode.

7. Adjust the wideband deviation limit potentiometer, R30 on the UHF Rx/Tx module (see Figure 3-6) to produce a  $\pm 4.25$  kHz deviation. Select narrow band mode on the UHF band and adjust the narrowband deviation limit potentiometer, R76 on the UHF Rx/Tx module to produce a  $\pm 2.15$  kHz deviation.
8. Verify that the deviation does not exceed  $\pm 5$  kHz for wideband and  $\pm 2.5$  kHz for narrowband on 403.000 MHz, and 512.000 MHz. Re-adjust R30 or R76 as required, if the deviation exceeds  $\pm 5$  kHz or  $\pm 2.5$  kHz, respectively.
9. Replace the bottom cover.

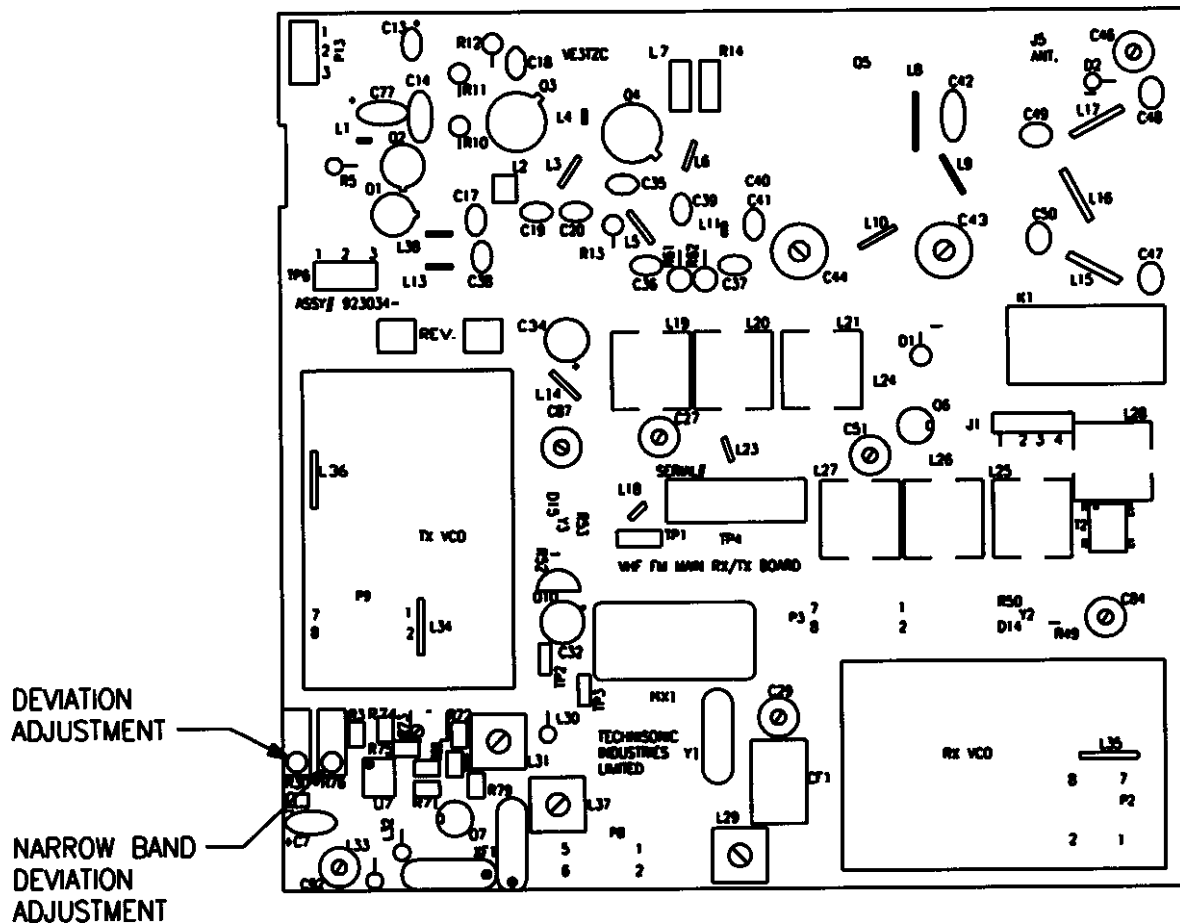

**VHF Receiver/Transmitter PCB Module**

Notes: R30 is for 5.0 kHz (wideband) Deviation Adjustment  
 R76 is for 2.5 kHz (narrowband) Deviaton Adjustment

**FIGURE 3-5 Deviation Adjustment Potentiometer Location**

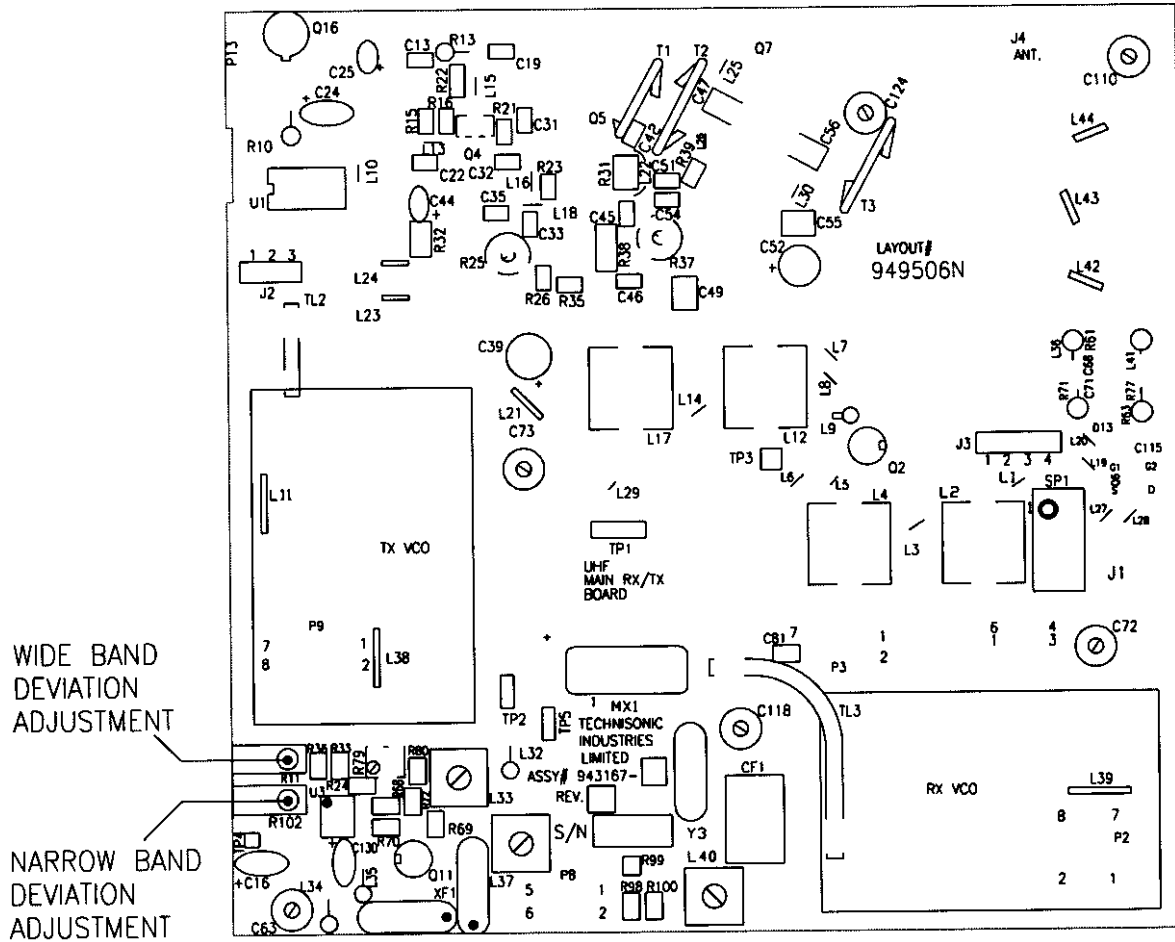

**UHF Receiver/Transmitter PCB Module**

Notes: R11 is for 5.0 kHz (wideband) Deviation Adjustment  
 R102 is for 2.5 kHz (narrowband) Deviaton Adjustment

**FIGURE 3-5 Deviation Adjustment Potentiometer Location**