

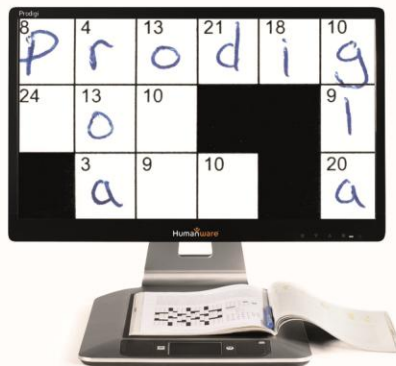

DUO

DESKTOP

TABLET





# CONTENTS

Chapter 1 – Introduction.....	2
Chapter 2 – Getting to know your Prodigis .....	3
Box contents .....	3
Prodigi Desktop at a glance.....	4
Setting up .....	7
Chapter 3 – Using Prodigis .....	10
Spot Reading.....	10
Auto Reading.....	12
Normal Reading.....	15
Manual Tasks .....	15
Chapter 4 – Switching to Standard Interface .....	17
Using Prodigis (Standard Interface) .....	18
Spot Reading (Standard Interface) .....	18
Normal Reading (Standard Interface) .....	20
Auto Reading (Standard Interface) .....	21
Manual Tasks (Standard Interface).....	22
Using the Carousel menu .....	23
Viewing saved Documents .....	24
Chapter 5 – Choosing your Contrast.....	25
Chapter 6 – Viewing a Video.....	27
Chapter 7 – Changing your Settings .....	28
Chapter 8 – Standing By and Powering off .....	32
Chapter 9 – Software Update.....	32
Chapter 10 – Troubleshooting.....	35
Appendix A: Safety and Maintenance .....	37
Appendix B: Specifications.....	40
Appendix C: Warranty .....	41

# CHAPTER 1 – INTRODUCTION

Thank you for purchasing Prodigy, the touch-controlled personal vision assistant system from HumanWare, global leader in assistive technologies for people who have low vision. Prodigy is a simple, intelligent, and adaptable line of products aimed at restoring and maintaining independence for people living with vision loss.

Prodigy Desktop will allow you to magnify and read documents, continue your favorite hobbies and activities, and carry out a wide range of manual tasks with ease and simplicity.

Carefully read the operating and safety instructions described in this user guide prior to using your Prodigy. This user guide describes the system functions based on Prodigy's manufacturer default settings. If you have any questions about your system, please contact HumanWare Customer Service by consulting the contact information in the back of this user guide.

Copyright 2015 by Technologies HumanWare Inc., all rights reserved. No part of this publication may be reproduced or distributed in any form or by any means, or stored in a database or retrieval system, without the prior written permission of Technologies HumanWare Inc.

# CHAPTER 2 – GETTING TO KNOW YOUR PRODIGI

## BOX CONTENTS

<b>Base box</b>	Base Unit Power Supply Power Cable Unboxing Guide Getting Started Guide User Guide Packing and Unpacking Guide Colored button overlay stickers Warranty Sheet Assembly kit (if your screen is not assembled): Screen Slider, 4 thumb screws, 2 screws, 1 Torx key, 1 cable clip, 1 masking membrane
<b>Screen box</b>	20 or 24 inch screen (if your screen is not assembled)

# PRODIGI DESKTOP AT A GLANCE

## Front Face

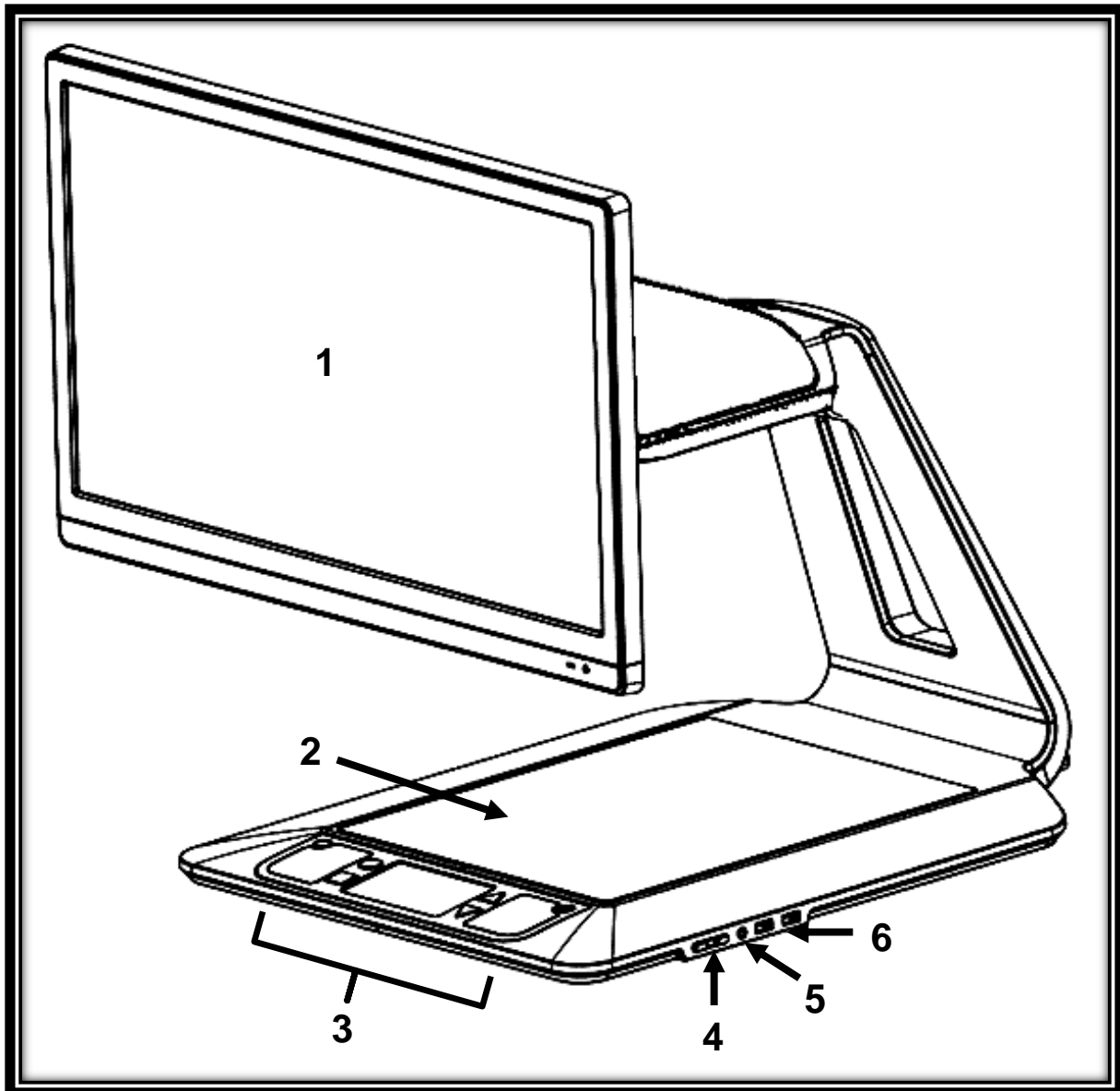

1. Screen
2. Viewing Zone
3. Control Panel
4. Plus-Minus keys
5. Audio Port

## 6. USB Ports (2)

### Control Panel

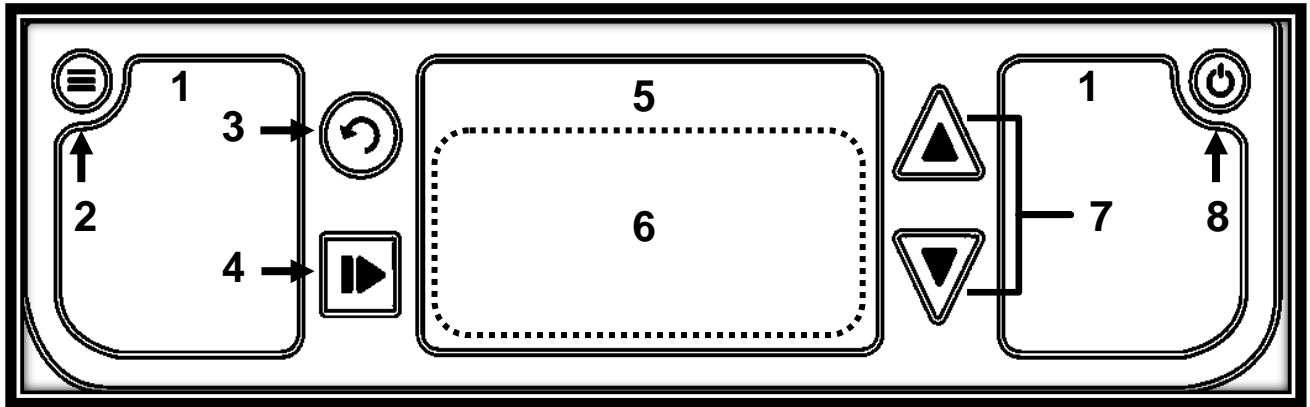

1. Speakers (2)
2. Settings Button
3. Back Button
4. Read Button
5. Touchpad
6. Touchpad Click
7. Zoom Up-Down Buttons
8. Power Button

## Back Side

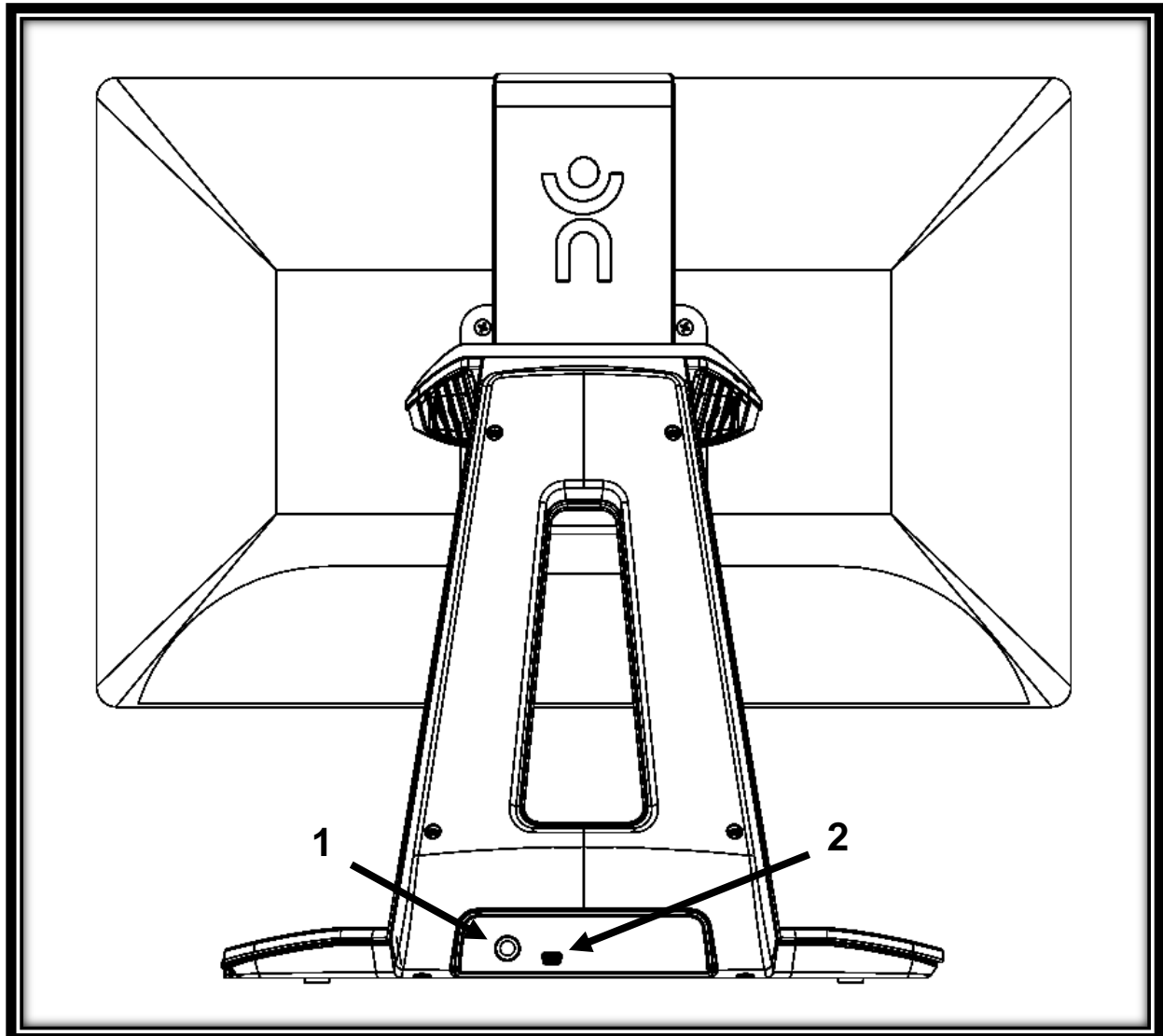

1. Power Connector
2. USB Port (factory use)



## SETTING UP

1. Pull the Base out of its box by holding the temporary cardboard handle, and place it on a flat and level surface.

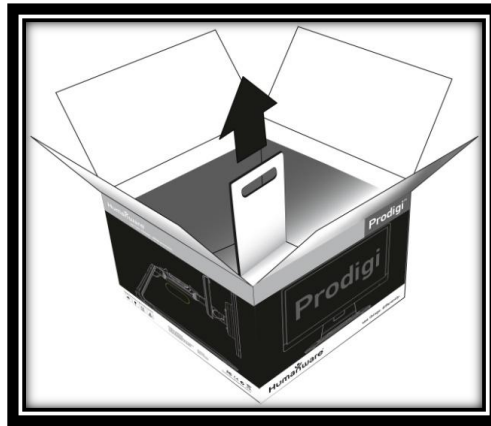

**Note:** The handle should only be used once.

2. (If the screen is assembled, skip to step 5.)  
Carefully take the screen out of its box and place it face down on a flat surface. Use the 4 thumb screws to secure the screen slider in place. Make sure the tactile HumanWare logo on the screen slider is facing towards the top of the screen (1).

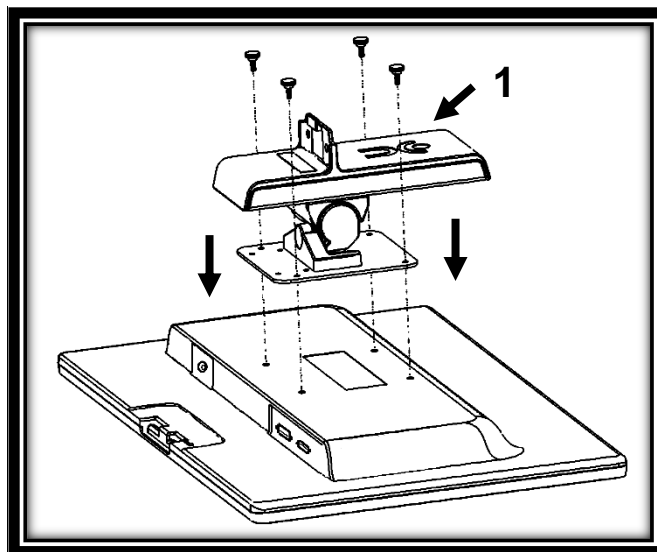

**IMPORTANT: Use caution while handling the screen to avoid scratching it.**

3. Tilt the screen forward and carefully insert the screen slider into the Base (1). Use the Torx key to tighten the 2 screws into the Base (2). Then, apply the masking membrane over the 2 screws (3).

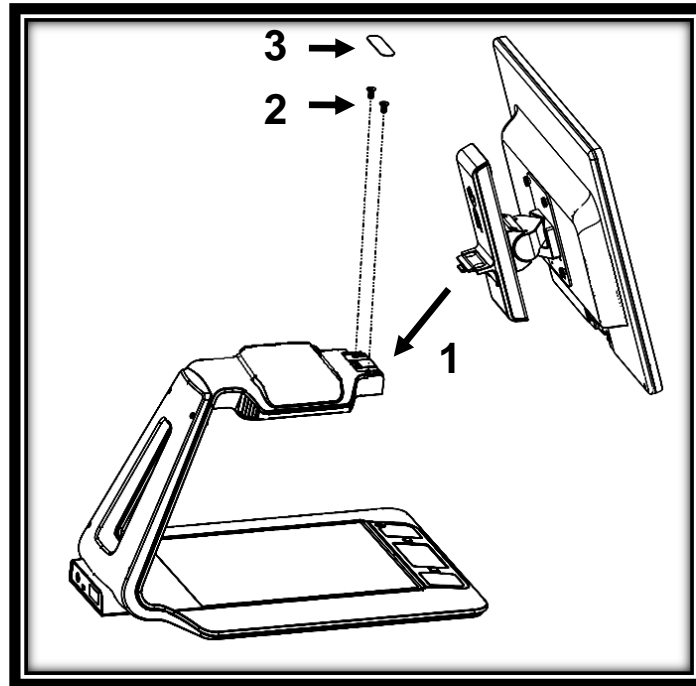

4. Connect the DC cable into the DC port (1). Then, insert the DVI cable into the DVI port and tighten the 2 included screws (2). Use the cable clip to attach the cables behind the screen (3).

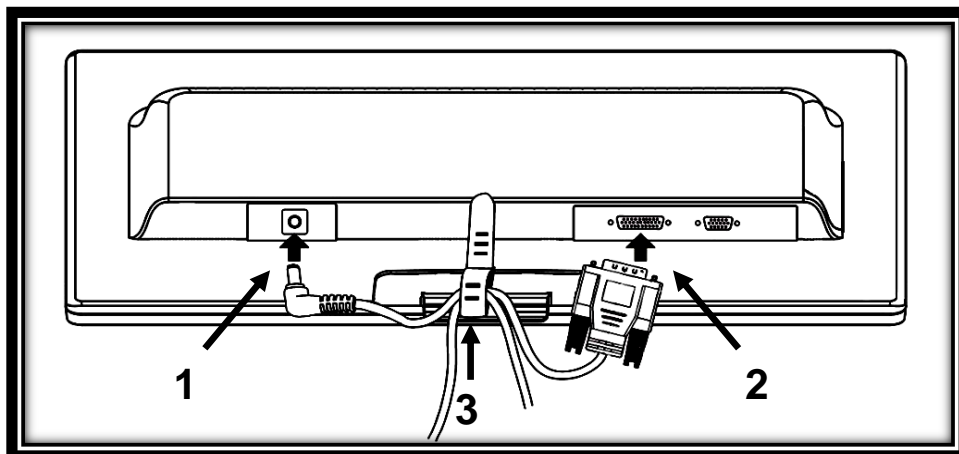

**IMPORTANT: The DVI cable only goes in one way. If it does not slide in properly, flip it over and try again.**

5. The center of the screen should be at the same height as your eyes, ideally 16 inches (40 cm) away. To adjust its position, lift up or down, tilt forward or back, and swivel left or right.

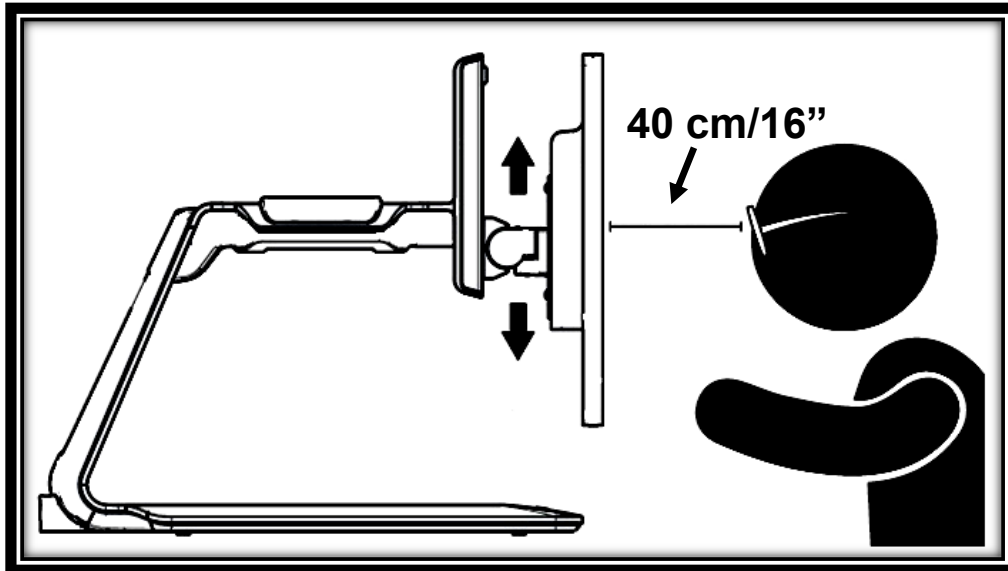

6. Connect the Power Supply to the Power Cable. Then, connect the cable to the Power Connector and plug it to an outlet.

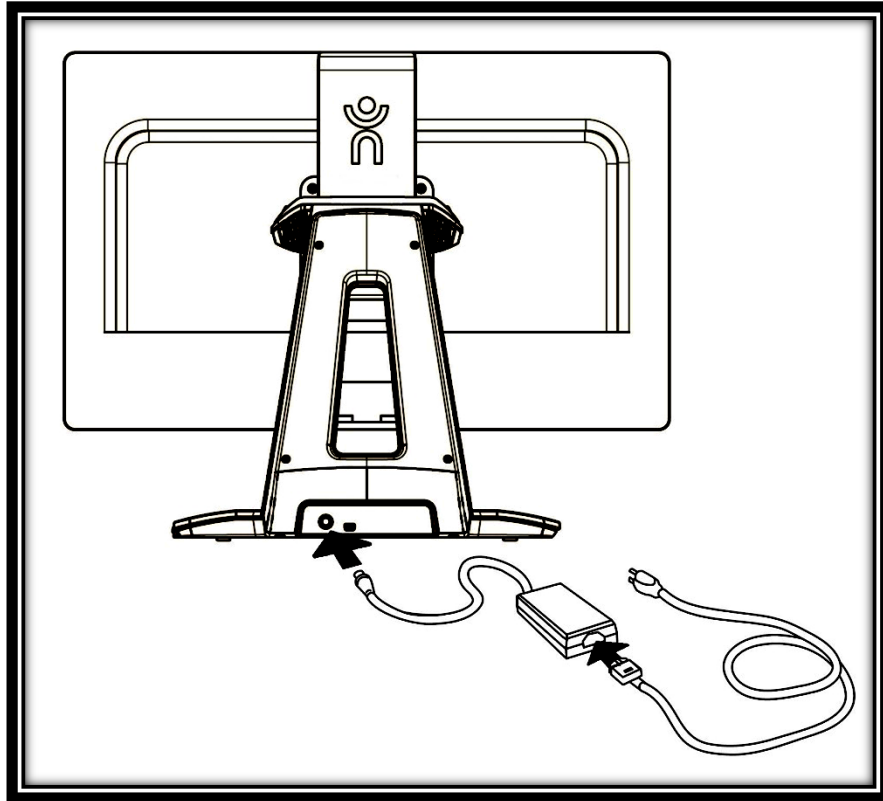

7. Press the Power button to power on the Desktop. Prodigy will take about 1 minute to initialize. HumanWare's logo will appear on the screen, followed by Prodigy's startup screen.

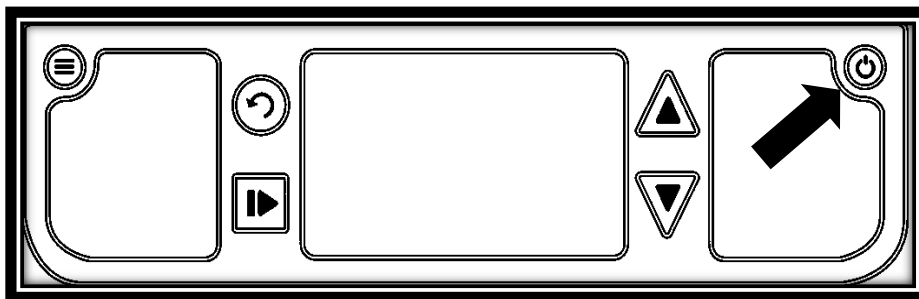

## CHAPTER 3 – USING PRODIGI

### SPOT READING

- After initializing, Prodigy will display a page placement frame on screen. Place your document in the viewing zone:

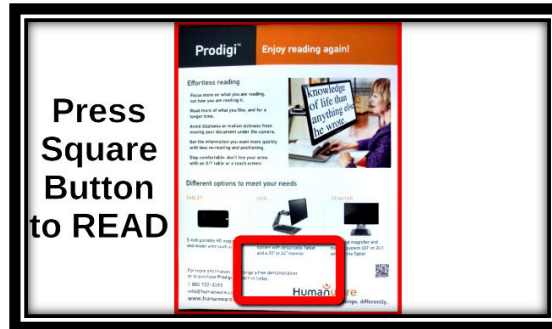

- To quickly reach a section of the document, move the **locator**, the rectangle at the bottom center of the screen, by slowly moving your finger on the touchpad without lifting it (**pan** gesture):

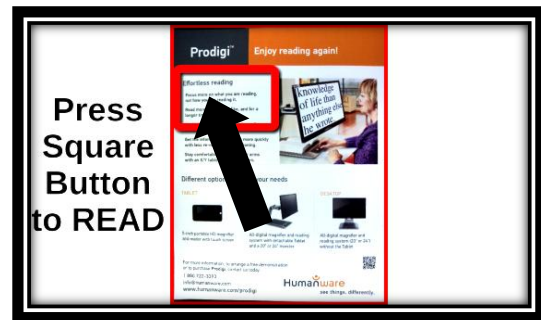
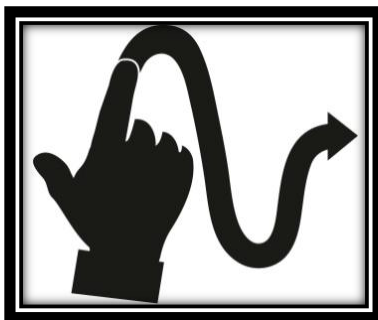

- **Click on the touchpad** (press down on the lower section of the touchpad until you hear a clicking sound) or press the **Zoom Up** button to enlarge the section delimited by the locator.
- Pan to reach other parts of the enlarged image.
- Press the **Zoom Up** button to zoom in and the **Zoom Down** button to zoom out. You can also press and hold the Zoom Up-Down buttons to progressively adjust the zoom level, and release once you reach your desired zoom level.
- To toggle between **color**, **positive**, and **negative** contrasts, press the **Settings** button to access the Settings menu, scroll down by panning upward on the touchpad to select Contrast, and press the Zoom Up-Down buttons or click on the touchpad to toggle between the different values. Press

Settings again to exit the Settings menu and return to your document.

- By default, Prodigy will read aloud the Settings' menus, items, and values. To deactivate Speech, access the Settings, select Speech and set it to Off. Exit the Settings to return to your document.
- While zoomed in, you can adjust the brightness of your document by accessing the Settings menu. Use the Zoom Up-Down buttons or click on the touchpad to adjust the brightness of your document in percentage. Once you reach your desired brightness level, exit the Settings or simply wait a few seconds to continue magnifying.
- Press Back to see the locator again. This is a practical way to locate your position on the page.
- Press Back again to reposition the locator at the bottom center of the screen.

## AUTO READING

As soon as you press Read, Prodigy will automatically capture, scroll and read aloud your document in Diamond Edge text according to your preferences. Diamond Edge contrast will also be available when toggling between contrasts.

- After initializing, Prodigy will display a page placement frame on screen. Place your document in the viewing zone:

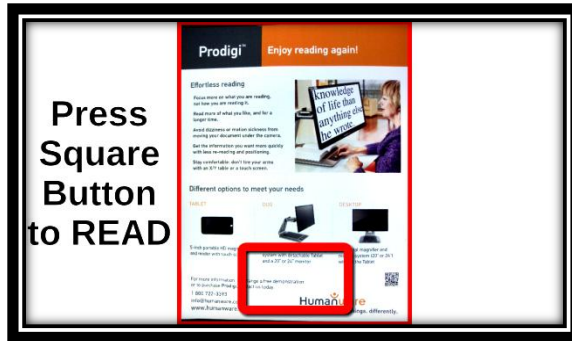

- To start reading from the top left corner of your document, simply press Read. You will hear a clicking sound indicating that your document has been captured, and Prodigy will scroll your document according to your reading preferences.

**Note:** To start reading from a specific place on your document, before pressing Read, move the locator by panning, and press the Zoom Up button or click on the touchpad to enlarge the text. Then, press Read once you reach a section you want to read.

- To adjust the volume, use the **Plus-Minus** keys (on the right edge of the base plate; the Minus key is the one closest to you).
- To pause, press Read.
- To resume, press Read again.
- When paused, pan in any direction (Page mode), up or down (Column mode), or left or right (Line mode) to go forward or back in the text.

**Note:** Text can be presented in 3 different ways (Reading Modes): it can be transformed into a single line in the Line mode, a column in the Column mode, or you can read text without losing its configuration in the Page mode (default). Two “greater than” inequality signs will mark the end of a paragraph in the Line and Column modes (>>). Prodigy will beep and announce “End of

document” when you reach the end of your document; press Read to start reading from the beginning again.

- To set a different Reading Mode, access the Settings, select Reading Mode and toggle the value. Exit the Settings menu to return to your document.
- You can increase the speech rate by **swiping to the left (sliding and releasing your finger to the left)** on the touchpad, and decrease the speech rate by **swiping to the right**. Note that changing the speech rate will change the reading speed (text scrolling speed) accordingly.

**Note:** You can also increase or decrease the speech rate from the Settings. Access the Settings, select Speech Rate, and use the Zoom Up-Down buttons or click on the touchpad to change the value. Exit the Settings.

- To deactivate Speech, access the Settings, select Speech and set it to Off. When Speech is deactivated, you will be able to change the reading speed (text scrolling speed) by swiping left or right, or from the Settings (in the Visual menu and Text submenu). In addition to deactivating speech from the Settings, you can toggle between Speech On and Off when reading a document by doing a **double click (quickly clicking twice on the touchpad)** gesture.  
You can toggle back to Speech On by pressing and holding the Read button anywhere in the Settings menu.
- Prodigy contains 2 different voices that can be used to read aloud text documents. To select a different voice, access the Settings, select Voice, and toggle between the 2 reading voices. Exit the Settings to return to your document. Make



sure that the language of the selected voice is the same as in the document you want to read.

- You can adjust the contrast and the brightness in the same way as when spot reading (see section Spot Reading above).
- Press Back to stop reading and return to the page placement frame.

## NORMAL READING

Prodigi's Read button can be set to Normal (the default value being Auto) to instantly enlarge and display Diamond Edge text according to your preferences with a single press (without reading it). After pressing Read a second time, Prodigi will scroll and read aloud the text according to your reading preferences.

To set the Read button to Normal:

- Access the Settings and select All Settings.
- Select Gestures and Controls.
- Select Read Button and set it to Normal.
- Exit the Settings.

## MANUAL TASKS

Prodigi is ideal for performing a wide range of manual tasks, such as viewing pill bottles, signing checks, and more. It allows for magnification up to 20x.

- After initializing, Prodigi will display a frame on screen. Place your object or document in the viewing zone:

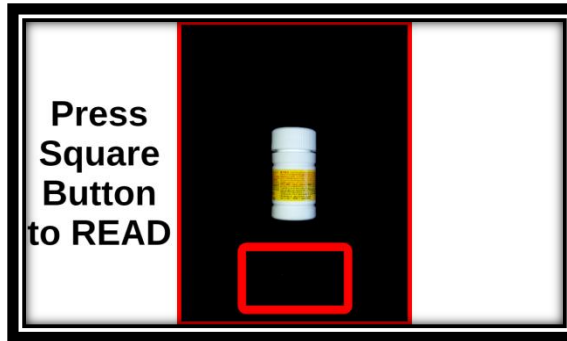

- Move the locator by panning to quickly reach a section of the object or document you want to magnify:



- Press the Zoom Up button or click on the touchpad to enlarge the section delimited by the locator at your preferred zoom level:



- You can navigate, zoom, adjust the brightness and change contrasts in the same way as when reading a document (see section Spot Reading above).
- Press Back to see the locator again.
- Press Back again to reposition the locator at the bottom center of the screen.

**Note:** If the image is unstable while executing a manual task, you can lock the Autofocus in the Settings. Access the Settings, select Autofocus and set it to Locked. Exit the Settings.

**Note:** If you cannot avoid touching the touchpad while executing a manual task, you can disable it in the Settings. Access the Settings, select Touchpad and set it to Disabled. Exit the Settings.

## CHAPTER 4 – USING STANDARD INTERFACE

Prodigi contains two different interfaces, Simple and Standard, which can be changed according to your specific needs. By default, Prodigi's interface is set to Simple (see previous chapter for more information). Prodigi's Standard interface allows you to

perform more touch gestures, keep documents in memory, and further customize your system.

To switch your interface to Standard:

- Access the Settings and select All Settings.
- Select General.
- Select User Interface.
- Select Yes.

**Note:** With the Standard Interface, use the tap gesture to select a value and zoom. You can also choose to click on the touchpad to select and zoom in the Settings (under Gestures and Controls, and Gestures).

## USING PRODIGI (STANDARD INTERFACE)

### SPOT READING (STANDARD INTERFACE)

After switching your interface to Standard, Prodigy will automatically launch the Magnifier in Read View and display the page placement frame on screen.

- Place your document in the page placement frame and remove your hands from the viewing zone:



- Prodigy will automatically capture your document. On the top left corner of the screen, Prodigy's locator will appear. You can now begin spot reading. Move the locator by panning to quickly reach a section of the document you want to read.
- Tap or press Zoom Up to enlarge the section delimited by the locator at your preferred zoom level in Diamond Edge Text.
- You can navigate in the enlarged text, adjust the zoom level, and adjust brightness in the same way as with the Simple interface (see chapter 3, section Spot Reading).
- You can now also use the **pinch and zoom** gesture to adjust the zoom level. **Decrease the distance between 2 fingers to zoom out, and increase the distance to zoom in:**



- In addition to changing the contrast from the Settings, you can toggle between **color**, **positive**, **negative**, and **Diamond Edge™** (for documents that contain text) contrasts by swiping on the right edge of the touchpad:

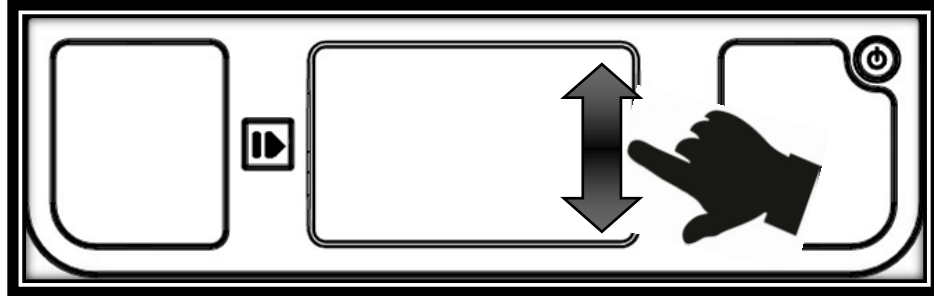

- To save the document you are reading, press and hold the Read button. The document will be kept in Prodigy's Gallery for future use.
- Tap or press Back to see the locator again. This is a practical way to locate your position on the page.
- Press Back again or remove your document from the viewing zone to return to the page placement frame.

## **NORMAL READING (STANDARD INTERFACE)**

As soon as you press Read, Prodigy will automatically scroll and read aloud your document in Diamond Edge text according to your reading preferences.

- Place your document in the page placement frame and remove your hands from the viewing zone:



- On the top left corner of the screen, Prodigy's locator will appear. You can move the locator by panning to quickly reach a section of the document you want to read. If you

want to start reading from the top of the page, do not move the locator.

- Press Read to instantly scroll and read aloud Diamond Edge text according to your reading preferences.
- To pause, press Read or Back.
- To resume, press Read again.
- On the Standard interface, in addition to deactivating speech from the Settings, you can toggle between Speech On and Off when reading a document by doing a **double tap (tapping twice quickly with 1 finger)** or double click gesture.
- While reading, use the **pinch and zoom** gesture to adjust the zoom level.
- You can navigate in the text, change the reading, mode, speech rate, or reading speed, adjust the volume, and select a different reading voice in the same way as on the Simple interface (see chapter 3, section Auto Reading).
- To save the document you are reading, press and hold the Read button. The document will be kept in Prodigy's Gallery for future use.
- While paused, tap or press Back to stop reading and see the locator again.
- Press Back again to go back to the page placement frame.

## **AUTO READING (STANDARD INTERFACE)**

Prodigi's Read button can be set to Auto (the default value being Normal on the Standard interface) to automatically scroll and read aloud the text according to your reading preferences after placing a document in the viewing zone.

To set the Read button to Auto:

- Access the Settings and select All Settings.
- Select Gestures and Controls.
- Select Read Button and set it to Auto.
- Exit the Settings.

## MANUAL TASKS (STANDARD INTERFACE)

- On the Standard interface, you can toggle between Read view and Live view by swiping on the left edge of the touchpad:

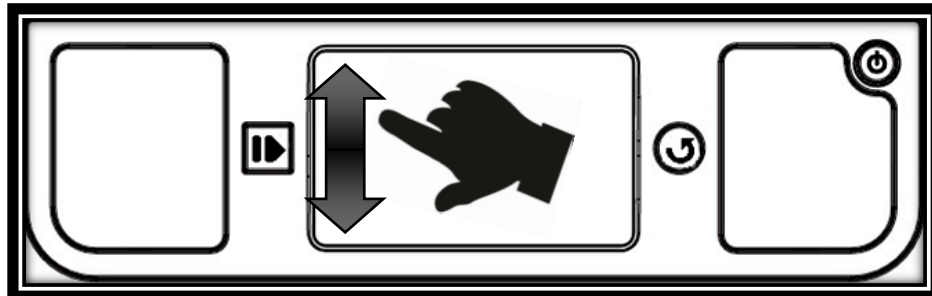

**Note:** You can also toggle to Live View in the Settings. Access the Settings, select View and set it to Live. Exit the Settings.

- You can now use the Magnifier to execute manual tasks. At the bottom center of the screen, you will notice Prodigi's locator. Move the locator over the area you wish to magnify and tap or press Zoom Up.



- You can navigate in the enlarged image, adjust the zoom level and the brightness in the same way as in Read View. See section Spot Reading (Standard Interface).
- Press Read to freeze (and Back to unfreeze) an image of what you are viewing. If your document contains text, you can use the same features as in Read view (see previous sections in this chapter).
- Press and hold the Read button to save an image of what you are viewing. It will be saved in Prodigy's Gallery for future use.
- Tap or press Back to see the locator again.

**Note:** As on the Simple interface, you can lock the camera's autofocus and disable the touchpad in the Settings. See chapter 3 (section Manual Tasks) to learn how.

## USING THE CAROUSEL MENU

Prodigi has 3 main applications – Magnifier, Gallery, and Settings. They are presented one by one in the carousel menu:



To access the carousel menu from the Magnifier:

- Press Back to exit the Magnifier and access the carousel menu.
- Prodigy will announce “Main Carousel” followed by the currently selected application. The currently selected application is positioned in the center of the screen.

- Swipe left or right in the carousel menu to select an application.
- To launch a selected application, simply tap.
- To cancel, press Back.

## VIEWING SAVED DOCUMENTS

The Gallery contains all the documents you saved. To access the Gallery:

- Select and launch the Gallery in the carousel menu:



- Swipe left or right in the Gallery to flip through your saved documents.
- The currently selected document is in the center of the screen. Prodigy will announce the first word contained in the currently selected document and indicate it below the document. If the document contains no words, Prodigy will tag it as an image.
- To open a selected document, simply tap.
- You can navigate on your document with the locator, adjust the zoom level and the brightness, and change your contrast in the same way as in the Magnifier. See section Using Prodigy (Standard Interface) for more information.
- Press Back again to close a document and return to the Gallery. Once you close a document, Prodigy will remember your position and apply it automatically the next time you open the document.

**Notes:** Prodigy will announce “Gallery empty” if the Gallery contains no documents. The Gallery cannot contain more than 100 documents. Once you pass this number, you will be prompted to delete some documents from the Gallery before saving new ones.

**To delete a document:**

- In the Gallery, press and hold your finger down on the image you want to delete. You will be prompted ‘DELETE?’ and a red ‘X’ will appear. Tap to confirm, or press Back to cancel.



**Note:** You can also delete all files in the Gallery from the Settings. See chapter 6 (section General) for more information.

## CHAPTER 5 – CHOOSING YOUR CONTRAST

Prodigi allows you to view documents, pictures and objects in 3 types of contrast: **color**, **positive** or **negative**. For documents

that contain text, a 4<sup>th</sup> type of contrast can be used: **Diamond Edge™**. Positive, negative, and Diamond Edge™ contrasts are enhanced; they are meant to enhance the original color of a document or object to facilitate your visual experience.

**Color** contrast is useful if you want to view documents, objects, and photographs in their original color.

**Positive** contrast shows text and images in 2 colors according to your selected color combination, the default combination being Black on White. This is a practical way to view text in the best color combination for your vision.

**Negative** contrast shows text and images in reversed contrast as compared to your selected color combination. For example, if your combination is Black on White, negative contrast will show text and images in White on Black. This is useful if you wish to reverse the contrast of a text that contains different contrasts.

**Diamond Edge™** contrast combines the best of both worlds; it shows Diamond Edge Text™ in your selected color combination and images in their original color. This allows you to magnify text indefinitely without compromising its quality in the best color combination for your vision, while viewing images in their original color on the same page.

To toggle between the different contrasts, access the Settings, select Contrast and toggle the value. Exit the Settings to return to your document or object.

Prodigi's Standard interface also allows you to toggle between the different contrasts by swiping on the right edge of the touchpad:

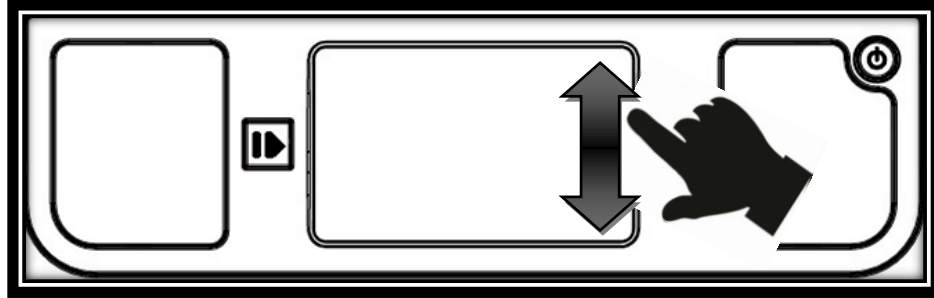

**Note:** The contrast cannot be changed while in Line or Column mode, or while viewing an image at 1x (Read View or Gallery).

## CHAPTER 6 – VIEWING A VIDEO

With Prodigy, you can view a video contained on a USB media:

- Simply insert the USB media into one of the USB ports on the right edge of the base plate.
- Prodigy will play the video automatically. If the media contains more than one file, its contents will be presented to you in a vertical list.
- Select a file you wish to view and tap or press Zoom Up to play the video.
- Use the Read button to pause and resume.
- Adjust the volume with the Plus-Minus keys.
- While viewing a video, tap to display video player information (file name, battery percentage, and video progress bar).
- Swipe right to move forward in the video, and left to move backward.
- Press Back or remove the USB media to exit the video and return to the previous screen.

**Note:** Prodigy supports most video resolutions and formats (720p to 1280p, .3gp, .webm, .ts, .mov, .mp4, .mkv, .avi, and .flv).

# CHAPTER 7 – CHANGING YOUR SETTINGS

(Note: The values marked with a star (\*) are manufacturer default settings.)

To quickly configure your system while viewing a document, press the Settings button to access the Settings menu. The currently selected item is announced and highlighted by a rectangular frame. Scroll up or down to move the rectangle and select an item. The items will be read one at a time (by default). Use the Zoom Up-Down buttons or click on the touchpad (Simple Interface) to toggle the values. Press Settings to exit the Settings and return to your document.

The Settings menu lists the most frequently used settings:

- **Brightness** (Change the brightness of a live or captured image, except for 1x image in Read view and in Gallery): 0 to 100% (50%\*)
- **Contrast:** Diamond Edge (if captured image contains text), Color\*, Positive, Negative
- **Colors:** Black on White\* (see list of 16 color pairs in main Settings below)
- **View** (Standard Interface): Read\*, Live
- **Reading Mode:** Page\*, Column, Line
- **Speech:** On\*, Documents only, Off
- **Speech Rate:** Very slow, Slow, Normal\*, Fast, Very fast
- **Voice:** Voice 1\*, Voice 2
- **Autofocus** (Live view only): Locked, Unlocked\*
- **Touchpad** (Live view only): Enabled\*, Disabled

You can further customize your system by selecting All Settings at the end of the Settings menu. With Prodigy's Standard interface,

you can also access these Settings by selecting and opening the Settings application in the carousel menu:

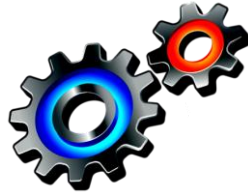

The Settings contain 5 main menus: Visual, Audio, Gestures and Controls, General, and About. Scroll up or down in the Settings to select a menu. Prodigy will announce “submenu” if a selected menu contains submenus and display an arrow on the right edge of the screen. To open a menu or submenu, select it and press the Zoom Up button or click on the touchpad (Simple Interface). Once you have reached the setting you want to modify, use the Zoom Up-Down buttons or click on the touchpad (Simple Interface) to toggle the value. Press Back to return to a previous screen. Press Settings to exit the Settings.

## VISUAL

The **Visual** menu contains 3 submenus:

**1. Display** contains the following settings:

- **View** (Standard Interface): Read\*, Live
- **Contrast:** Diamond Edge (if captured image contains text), Color\*, Positive, Negative (see chapter 5)
- **Diamond Edge:** Always\*, On Request (see chapter 5)
  
- **Colors** (Select from 16 color pairs): Black on White\*, White on Black, Yellow on Black, Orange on Black, Cyan on Black, Purple on Black, Green on Black, Black on Green, Black on Purple, Black on Cyan, Black on Orange, Black on

Yellow, Blue on Yellow, Yellow on Blue, White on Blue, Blue on White

- **Locator Color** (change the locator's color): Red\*, Orange, Yellow, Purple, Cyan, Green, Blue
- **Preferred Zoom** (change the locator's initial zoom level): 2 to 35x (4x\*)

2. **Text** contains the following settings:

- **Reading Mode:** Page\*, Column, Line
- **Reading Speed:** Very slow, Slow, Normal\*, Fast, Very fast
- **Font Size:** Minimum, Small, Medium, Standard\*, Large, Very large, Extra large, Maximum
- **Font Type:** Regular, Bold\*
- **Highlight** (Column and Line modes only. Highlight on spoken words): Display\*, Hide

3. **Camera** contains the following settings:

- **Auto Capture Delay** (change your page capture delay in Read View): 2 sec\*, 4 sec, 6 sec

## AUDIO

The **Audio** menu contains the following settings:

- **Sounds:** On\*, Off
- **Speech:** On\*, Documents only, Off
- **Speech Rate:** Very slow, Slow, Normal\*, Fast, Very fast
- **Voice:** Voice 1\*, Voice 2

## GESTURES AND CONTROLS

The **Gestures and Controls** menu contains the following submenus:



1. **Gestures** (Enable and disable gestures. By default, all gestures are deactivated on Simple interface and activated on Standard interface):
  - **Swipe on left edge / View** (Standard interface only): Toggle between Read and Live views.
  - **Swipe on right edge / Contrast**: Toggle between Color, Positive, Negative, and Diamond Edge™ contrasts (Note: The last selection will be saved in Prodigy's memory).
  - **Pinch and Zoom**: Adjust the zoom level by decreasing or increasing the distance between 2 fingers.
  - **Double tap / Speech**: Toggle between Speech On and Off by tapping twice quickly with 1 finger.
  - **Select / Zoom**: Click\*, Tap (Tap\* on Standard Interface)
2. **Touchpad**: Enabled\*, Disabled
3. **Read Button**: Auto\*, Normal (Normal\* on Standard Interface. Configure the behavior of the Read button. See chapters 3 and 4)

## GENERAL

The **General** menu contains the following items:

- **User Interface**: Simple\*, Standard
- **System Language**: Language 1\*, Language 2 (Choices depend on country or region)
- **Wi-Fi Setup** (USB mouse required. Help of a sighted person required)
- **Base Auto Shutoff**: 5 min, 10 min, 30 min\*, 60 min
- **Software Update** (see chapter 9)
- **Touchpad Sensitivity**: Low, Normal\*, High
- **Delete Gallery content** (Standard interface only): Permanently delete all files in Gallery.
- **Restore to Factory Defaults**

## ABOUT

The **About** menu contains the following items:

- **Software** (Version)
- **Serial Number**
- **Model**
- **Base** (Version)
- **Touchpad** (Version)
- **Android** (Version)

## CHAPTER 8 – STANDING BY AND POWERING OFF

In a working situation where you need Prodigy intermittently, you can enter Standby mode when you are not using Prodigy by pressing Power quickly. The screen will power off. Exit Standby mode by pressing Power quickly again.

If you will not be using Prodigy for the next few days or disconnect it from power source, it is recommended to power it off by pressing and holding the Power button. Prodigy will ask you if you want to power off. Press Zoom Up or click on the touchpad to select OK and power off, or press Back to cancel. To power it back on, press Power again. Prodigy will take about 1 minute to initialize. HumanWare's logo will appear on the screen, followed by Prodigy's startup screen.

## CHAPTER 9 – SOFTWARE UPDATE

There are 2 ways to update Prodigy's software: with a USB stick (from software version 1.1 and higher) and wirelessly.

## **To update with a USB stick:**

- First, visit our website [www.humanware.com/prodigi\\_support](http://www.humanware.com/prodigi_support) and copy the update file on a USB stick (of at least 512 MB). You can also contact HumanWare to have a USB stick with the update file mailed to you (see contact information on the back side of this user guide).
- Make sure your Prodigy is powered on, and insert the USB stick in one of the 2 USB ports on the right edge of the base plate.
- Prodigy will show you the update's version number and language. Confirm your choice. If there is more than one update on the USB stick, select your update and confirm.
- Prodigy will download the update file and display the download progress in percentage.
- To cancel the update, simply remove the USB stick from the USB port before it is downloaded. The file will not be deleted from the USB stick.
- Once the download is complete, Prodigy will reboot and install the update automatically. Android's green logo will be shown on screen during the update.
- Once the update is installed, the update file will be deleted from the USB stick after reboot.

## **To update wirelessly:**

Before initiating a software update, the WI-FI network has to be configured with a USB mouse (not included) and with the help of a sighted person.

- Press and hold the Back button to access the Settings and select All Settings. Tap to open. Select General and tap. Select WI-FI Setup and tap.
- Connect the USB mouse to one of the USB ports on the right edge of the base plate.
- Using the mouse, click on the OFF button to switch it to ON.
- Click on the network you wish to configure to open it.
- Scroll down in the network box and click on the space provided below “Password” to enter your password. A virtual keyboard will appear. Enter your password by clicking on the letters and/or numbers, followed by Done to confirm.
- Click on Connect to connect to the network.
- You can now disconnect the mouse. Press Back twice to return to General in Prodigy’s Settings.

**Note:** If you don’t have a USB mouse, you can also use a USB keyboard to configure the WI-FI network. Use the arrow keys to navigate on the screen.

- To initiate a software update, select Software Update and tap.
- Once the WI-FI connection is established, Prodigy will tell you whether your software is up to date or whether an update is available.
- If an update is available and you wish to install it, select Install and tap. If you wish to cancel, select Cancel and tap.
- If you chose to install the update, Prodigy will download the update and show the download progress in percentage.
- Once the download is complete, Prodigy will reboot and install the update automatically. Android’s green logo will be shown on screen during the update.

## CHAPTER 10 – TROUBLESHOOTING

### **If the image/text is out of focus or blurry:**

- Remove the document from the viewing zone and place it back again.

### **If the screen is blank:**

- Zoom out of the image for minimum magnification.
- Prodigy could be powered off or in Standby Mode. Press Power to power it on or to exit Standby Mode.

### **If colors are difficult to detect:**

- Check if you have sufficient ambient light.
- Choose a different contrast or color combination in the Settings.
- Adjust the brightness level in the Settings.

### **If there is a lot of glare:**

- Tilt object in a different angle to reduce glare.
- Reduce the brightness level in the Settings.
- Reduce external lighting effects.

### **If the audio reading does not make sense:**

- Make sure the Voice language is the same as your document's language. Change it in the Settings if necessary.

### **If the Desktop is not responding:**

- Check all connections and make sure that they are plugged in properly.

- Check that the screen is switched on, as indicated by the glowing blue light. If the screen is off, make sure the Desktop is powered on by pressing the Power button. If the screen stays off, press and hold the tactile power button on the bottom right corner of the screen for 8 seconds to switch it on.
- Check that the power is switched on at the wall socket.

**If the touchpad is not working:**

- Make sure the Touchpad is set to Enabled in the Settings.

**If the touchpad is not responding correctly:**

- Try making the Touchpad Sensitivity lower or higher in the Settings.

**If the Autofocus is not working:**

- Make sure the Autofocus is set to Unlocked in the Settings.

**Other problems:**

- Restore factory defaults in the Settings.
- Press and hold the Power button for 10 seconds and release. Wait 30 seconds, and press Power again.
- Contact your dealer or technical support.

# APPENDIX A: SAFETY AND MAINTENANCE

## Safety Instructions:



The above LED light warning label is intended to inform the user of the presence of a Class 2 LED product. The warning label is placed between the 2 LED light sources above the viewing zone. The user must not stare at the LED light sources.

Keep away from water or high humidity. Do not submerge.

Power off your Prodigy before cleaning it.

Use only cables provided with your Prodigy.

The outlet should be near the Desktop and easily accessible.

This product should be operated from the type of power indicated on the marking label. If you are unsure of the type of power available, consult your dealer or local power company.

Only use your Prodigy indoors. Do not expose it to sudden or extreme changes in temperature or humidity conditions. This product should not be placed near a heat source or exposed to direct sun light for a prolonged period of time.

Refer all servicing of this product to qualified service personnel. Do not attempt to service it yourself, as opening or removing covers may expose you to dangerous voltage points or other risks.

### **Susceptibility to Interference:**

There may be temporary degradation of the image when Prodigy is subjected to a strong radio-frequency field, electro-static discharge or transient electrical noise. An electro-static discharge (caused by static electricity) may cause the screen to go blank. If this happens, power the system off and on again.

### **Warning RF Exposure Compliance:**

The antenna(s) used for this transmitter must be installed to provide a separation distance of at least 20 cm from all persons and must not be co-located or operating in conjunction with any other antenna or transmitter. Users and installers must be provided with antenna installation instructions and transmitter operating conditions for satisfying RF exposure compliance.

### **Industry Canada statements/ Avertissements d'Industrie Canada**

This device complies with Industry Canada licence-exempt RSS standard(s). Operation is subject to the following two conditions: (1) this device may not cause interference, and (2) this device must accept any interference, including interference that may cause undesired operation of the device.

Le présent appareil est conforme aux CNR d'Industrie Canada applicables aux appareils radio exempts de licence. L'exploitation est autorisée aux deux conditions suivantes : (1) l'appareil ne doit



pas produire de brouillage, et (2) l'utilisateur de l'appareil doit accepter tout brouillage radioélectrique subi, même si le brouillage est susceptible d'en compromettre le fonctionnement.

**Per Industry Canada RSS rules:**

This device complies with Health Canada's Safety Code. The installer of this device should ensure that RF radiation is not emitted in excess of the Health Canada's requirement. Changes or modifications not expressly approved by the party responsible for compliance could void the user's authority to operate the equipment.

**FCC Warning:**

This device complies with part 15 of the FCC Rules. Operation is subject to the following two conditions: (1) This device may not cause harmful interference, and (2) this device must accept any interference received, including interference that may cause undesired operation.

**CAUTION:** Changes or modifications not expressly approved by the party responsible for compliance could void the user's authority to operate the equipment.

**Note:** This equipment has been tested and found to comply with the limits for a Class B digital device, pursuant to part 15 of the FCC Rules. These limits are designed to provide reasonable protection against harmful interference in a residential installation. This equipment generates, uses and can radiate radio frequency energy and, if not installed and used in accordance with the instructions, may cause harmful

interference to radio communications. However, there is no guarantee that interference will not occur in a particular installation. If this equipment does cause harmful interference to radio or television reception, which can be determined by turning the equipment off and on, the user is encouraged to try to correct the interference by one or more of the following measures:

- Reorient or relocate the receiving antenna.
- Increase the separation between the equipment and receiver.
- Connect the equipment into an outlet on a circuit different from that to which the receiver is connected.
- Consult the dealer or an experienced radio/TV technician for help.

### **Maintenance and Disposal Instructions:**

Wipe your Prodigy's surfaces with a soft and dry cloth.

At the end of Prodigy's operational lifetime, its internal components must be disposed in compliance with local authorities.

Prodigi contains no hazardous materials. For disposal, return to HumanWare or follow local governing ordinances or hospital procedure.

## **APPENDIX B: SPECIFICATIONS**

### **Operating Conditions:**

- Temperature: 0 to 35 °C / 32 to 95 °F

- Humidity: 5 to 95%

### **Transport and Storage Conditions:**

- Temperature: -20 to 60 °C / -4 to 140 °F
- Humidity: 5 to 95%

### **Power Supply:**

- Input Voltage: 19 V

## **APPENDIX C: WARRANTY**

HumanWare warrants Prodigy, effective from the date of delivery, to be free of any defects in material and workmanship for a period of 1 year unless otherwise required by law in the country or region of purchase.

This warranty is non-transferable and applies to all cases where the damage is not a result of improper use, mistreatment, or negligence. Improper use is use of this device other than described in this manual. In no event shall HumanWare or its distributors be liable for indirect or consequential damages.

No replacement or repair covered by the warranty will be carried out unless the system is accompanied by a copy of the original bill of purchase. Please keep your original receipt. If the system has to be returned, please use the original packaging.

[End of document VER-09-2015-03-23]







## Customer support

For customer support, please contact the HumanWare office nearest you or visit our Website at:  
[www.humanware.com/prodigi\\_support](http://www.humanware.com/prodigi_support)

**Global:** [support@humanware.com](mailto:support@humanware.com)

**North America:** 1 (800) 722-3393  
[us.support@humanware.com](mailto:us.support@humanware.com)

**Europe:** (0044) 1933 415 800  
[eu.support@humanware.com](mailto:eu.support@humanware.com)

**Australia / Asia:** (02) 9686 2600  
[au.sales@humanware.com](mailto:au.sales@humanware.com)