

NOTE: The IP22CGV2 and IP532CG have similar physical and operational characteristics. To ensure that you are installing the correct unit, review the label on the back of the unit and check the bottom panel.

5.2.2.1 DC Power Cable Sizing Procedures

The IP532CG comes with a five (5) meters DC power cable. The Digital Life Technician (DLT) has the ability to shorten the cable based on the residential requirement.

To shorten the DC power cable length:

1. Remove the DC power (Y-cable) connector from the installation kit or the Cisco HPAV unit (if applicable).
2. Measure and mark the appropriate amount of DC Power (Y-cable) to be removed.
3. Using wire cutters, cut the DC Power (Y-cable) to the desired length.

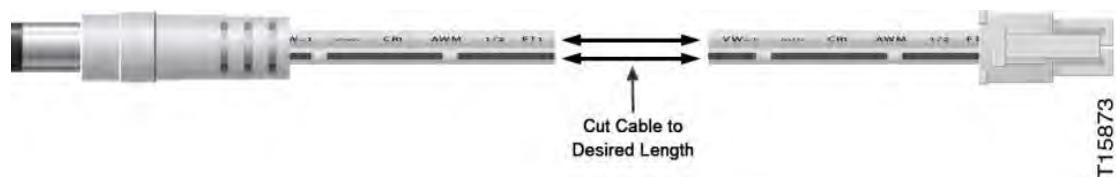

4. Reattach the DC Power (Y-cable) connector.

CAUTION:

Carefully observe the **CABLE MARKINGS** when reattaching the cable.

5. Connect the DC power (Y-cable) connector to the Cisco Unit, if applicable.

5.3 HPAV Pairing Procedures for Installations with a DLC-200C

The following subsections explain how to generate a new random security key and then pair a IP522CG with another IP522CG and possibly one, or more, IP532CG units.

5.3.1 Pairing Two (2) IP522CG Units

To pair an IP522CG unit and another IP522CG unit:

1. Plug two (2) IP522CG units into a power strip.

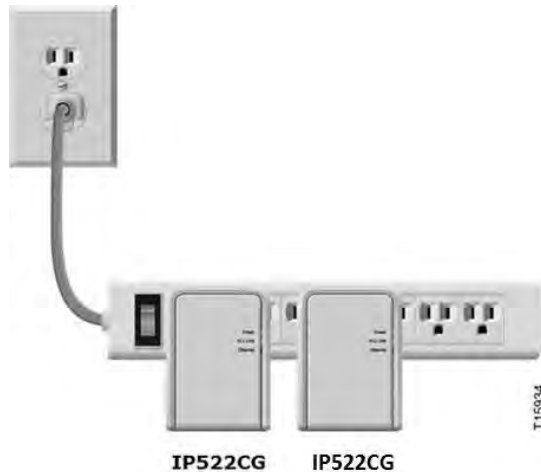

2. Randomize the security key on the first IP522CG unit on the left , by pressing the Pairing button on the IP522CG unit for more than 11 seconds until all three LEDs go off, then release the Pairing button.
3. Randomize the security key on the second IP522CG unit on the right, by pressing the Pairing button on the IP522CG unit for more than 11 seconds until all three LEDs go off, then release the Pairing button.
4. Press the Pairing button on the left IP522CG unit for 3-5 seconds then release the Pairing button. When you release the Pairing button the Power LED will start to flash indicating that the IP522CG unit is in the pairing mode.
5. Within two (2) minutes after pressing the left IP522CG unit's Pairing button, press the Pairing button on the right IP522CG unit for 3-5 seconds then release the Pairing button. When you release the Pairing button on the right IP522CG, the Power LED will start to flash indicating that the IP522CG unit is in the pairing mode and then after a few seconds the Power LED and PLC LED will illuminate SOLID green indicating that the units are now paired.

WARNING!

It is critically important that you **firmly press** the Pairing button on the IP522CG unit during the random key selection and pairing processes, and observe the LED behavior. Because of the physical design of the Pairing button on the IP522CG unit, you may need to use a hard, pointed object, such as a ballpoint pen, to press and firmly hold down the Pairing button. Unfortunately, there is no tactile feedback that indicates that the button has been actuated. When you are using the Pairing button for pairing, remember to **release** the button **after 3-5 seconds** and the Power LED will start flashing to confirm that the unit is in the pairing mode.

5.3.2 Pairing IP522CG and IP532CG Units

To pair an IP522CG unit and IP532CG unit:

1. Plug an IP522CG unit and an IP532CG unit into a power strip with the IP522CG unit on the left.

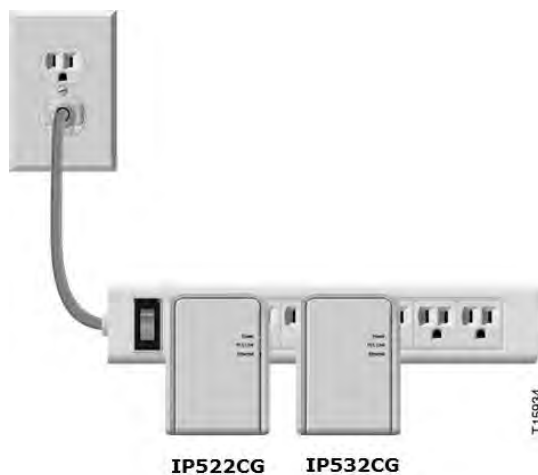

2. Randomize the security key on the IP522CG unit, by pressing the Pairing button on the IP522CG unit for more than 11 seconds until all three LEDs go off, then release the Pairing button.
3. Randomize the security key on the IP532CG unit, by pressing the Pairing button on the IP532CG unit for more than 11 seconds until all three LEDs go off, then release the Pairing button.

4. Press the Pairing button on the IP522CG unit for 3-5 seconds then release the Pairing button. When you release the Pairing button the Power LED will start to flash indicating that the IP522CG unit is in the pairing mode.
5. Within two (2) minutes after pressing the IP522CG unit's Pairing button, press the Pairing button on the IP532CG unit for 3-5 seconds then release the Pairing button. When you release the Pairing button on the IP532CG, the Power LED will start to flash indicating that the IP532CG unit is in the pairing mode and then after a few seconds the Power LED and PLC LED will illuminate SOLID green indicating that the units are now paired.

WARNING!

It is critically important that you **firmly press** the Pairing button on the IP522CG unit during the random key selection and pairing processes, and observe the LED behavior. Because of the physical design of the Pairing button on the IP522CG unit, you may need to use a hard, pointed object, such as a ballpoint pen, to press and firmly hold down the Pairing button. Unfortunately, there is no tactile feedback that indicates that the button has been actuated. When you are using the Pairing button for pairing, remember to **release** the button **after** 3-5 seconds and the Power LED will start flashing to confirm that the unit is in the pairing mode.

5.3.3 Pairing Additional IP532CG Units

To pair an additional IP532CG unit:

1. Plug an additional IP532CG unit into the power strip (leaving the first two HPAV units plugged into the power strip).

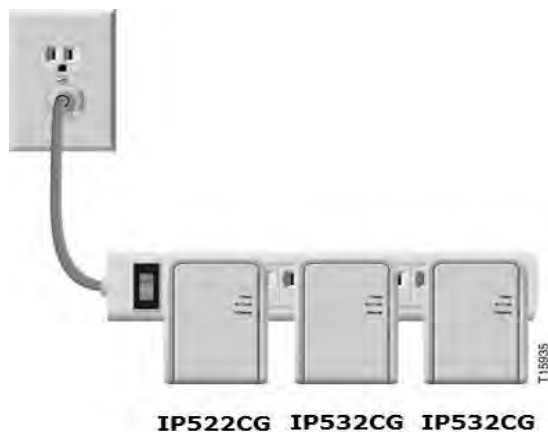

2. Press the Pairing button on the IP522CG unit for 3-5 seconds then release the Pairing button. When you release the Pairing button the Power LED will start to flash indicating that the IP522CG unit is in the pairing mode.
3. Within two (2) minutes, press the Pairing button on the IP532CG unit for 3-5 seconds and then release the Pairing button. When you release the Pairing button on the IP532CG, the Power LED will start to flash indicating that the IP532CG unit is in the pairing mode and then after a few seconds the Power LED and PLC LED will illuminate SOLID green indicating that the units are now paired. At this point, all three HPAV Devices are paired.
4. Unplug the second IP532CG unit from the power strip.

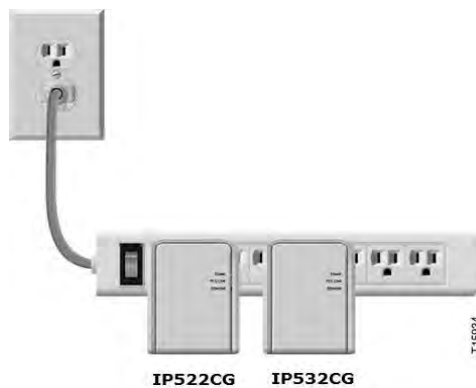

5. To pair any additional IP532CG units, repeat Steps 1-4, until all desired IP532CG units are paired.
6. Install all HPAV devices in their designated locations and verify that they work properly.

NOTE: When a HPAV unit is plugged into an AC outlet both the Power LED and PLC LED should illuminate after detecting existence of another paired device with the same security key. The Power LED should be SOLID green and the PLC Link LED should be SOLID green or BLINKING green.

NOTE: As was noted previously, an IP522CG unit can be installed with an IP Camera, but this is **not** the preferred installation. IP532CG units should be installed with IP Cameras.

5.4 *DLC-200C Installation with a Direct Ethernet Connection to the Broadband Home Router*

When the DLC-200C is installed in proximity to the customer's BHR, then the DLC-200C can be directly connected via Ethernet/Cat5 to an available Ethernet port on the Broadband Home Router (See Figure 33).

Figure 33: DLC-200 Installation with a Direct Ethernet Connection to the Broadband Home Router

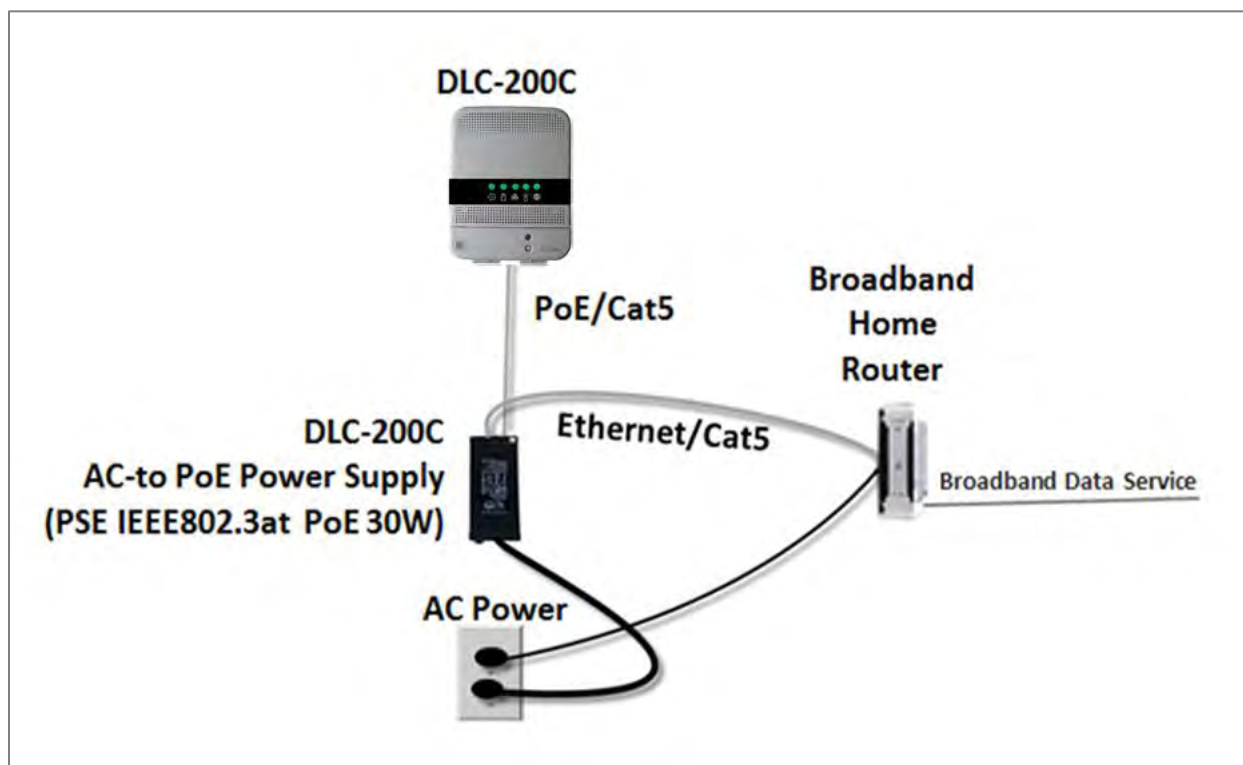

5.5 DLC-200C Installation with an AC-to-PoE Power Supply and HPAV to Ethernet Bridge

The DLT will install the DLC-200C with an AC-to-PoE Power Supply and an IP522CG as shown in Figure 34 at the planned location.

Figure 34: DLC-200C Installation with AC-to-PoE Power Supply and HPAV to Ethernet Bridge

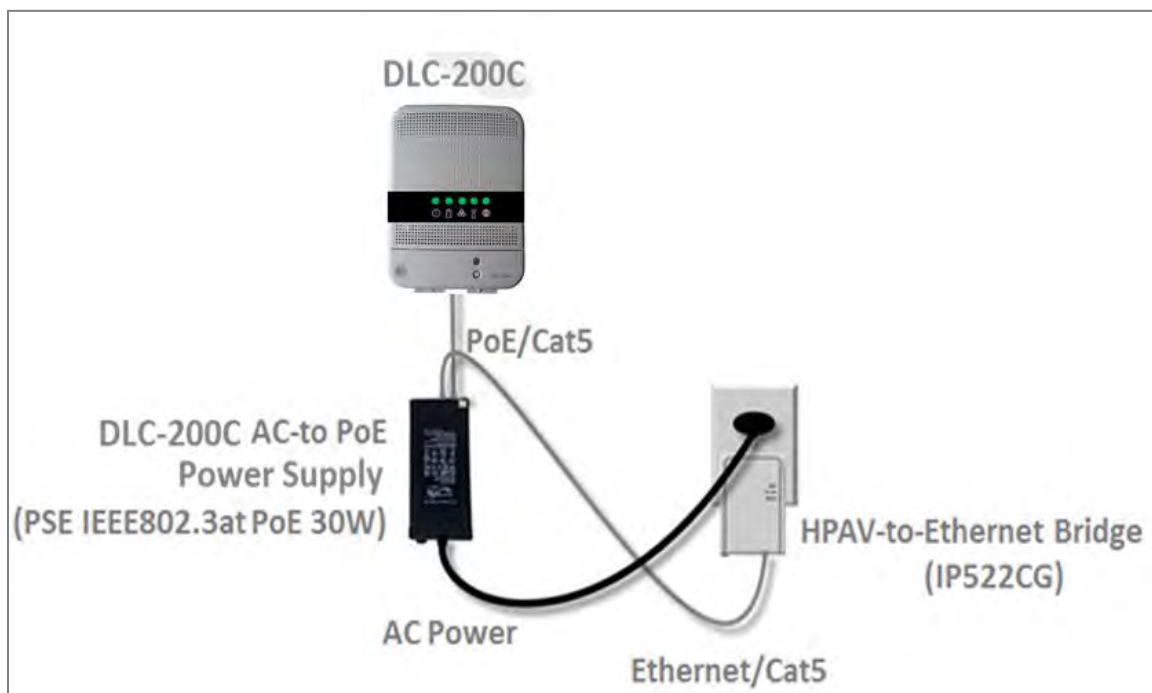

Next, the DLT will go to the location of the customer's Broadband Home Router (BHR) and install a HomePlug AV (HPAV) to Ethernet Bridge (IP522CG) and establish an Ethernet connection with the BHR using a Cat5/Cat6 cable. The DLT will verify that there is a HPAV network connection between the IP522CG at the customer's BHR and the IP522CG at the planned location of the installation of the DLC-200C.

Afterwards, the DLT will return to the planned location for the installation of the DLC-200C and proceed with the installation of the cabinet. This step includes connecting a the PoE/Cat5 (power and data) cable to the PoE port on the AC-to-PoE Power Supply and the WAN port on the DLC-200C cabinet.

5.6 Summary of System Installation

In summary, there are the eight (8) steps for installing the DLC-200C cabinet with an AC-to-PoE Power Supply and a HPAV to Ethernet Bridge when the DLC-200C Wall Mounting Plate is equipped with AT&T Cellular Data Modem :

1. Check AT&T Cellular Data Service signal strength
2. Prepare the HPAV devices for installation by pairing the devices
3. Install DLC-200C with AC-to-PoE Power Supply and HPAV to Ethernet Bridge
4. Install the HPAV unit (IP522CG) at the location of the customer's BHR
5. Observe LEDs
6. Establish Ethernet Connection to Customer's BHR
7. Observe LEDs
8. Return to Location of DLC-200C cabinet

STEP 1. Check AT&T Cellular Data Service signal strength.

Action
1. Check AT&T Cellular Data Service signal strength in the home and select the location for the installation of the DLC-200C cabinet.
2. The DLT will take measurements of AT&T Cellular Data signal strength at various locations in the home using an application executing on their wireless tablet device. The DLT will take into consideration AT&T Cellular Data Service signal strength measurements when determining where to install the cabinet.

STEP 2. Prepare the HPAV devices for installation.

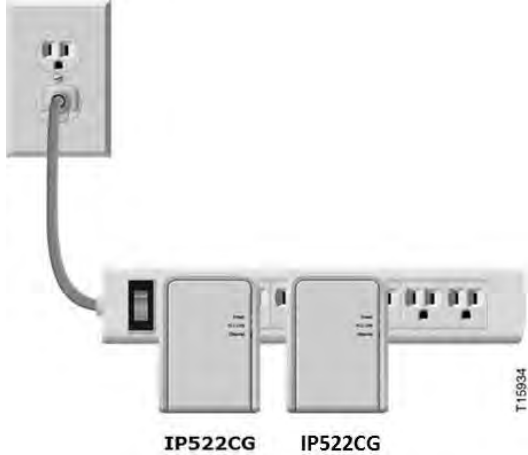
Action	Illustration(s)
<p>Pairing the two IP522CG units</p> <ol style="list-style-type: none"> 1. Plug two (2) IP522CG units into a power strip. 2. Randomize the security key on the left IP522CG unit, by pressing the Security button device for more than 11 seconds until all three LEDs go off, then release the Security button. 3. Randomize the security key on the right IP522CG unit, by pressing the Pairing button for more than 11 seconds until all three LEDs go off, then release the Pairing button. 4. Press the Security button on the left IP522CG unit for 3-5 seconds then release the Security button. When you release the Security button the Power LED will start to flash indicating that the IP522CG unit is in the pairing mode. 5. Within two (2) minutes after pressing the left unit's Security button, press the Pairing button on the right IP522CG unit for 3-5 seconds then release the Pairing button. When you release the Pairing button on the right IP522CG, the Power LED will start to flash indicating that the IP522CG unit is in the pairing mode and then after a few seconds the Power LED and PLC LED will illuminate SOLID green indicating that the units are now paired. 	 <p>WARNING!</p> <p>It is critically important that you firmly press the Pairing button on the IP522CG unit during the random key selection and pairing processes, and observe the LED behavior. Because of the physical design of the Pairing button on the IP522CG unit, you may need to use a hard, pointed object, such as a ballpoint pen, to press and firmly hold down the Pairing button. Unfortunately, there is no tactile feedback that indicates that the button has been actuated. When you are using the Pairing button for pairing, remember to release the button after 3-5 seconds and the Power LED will start flashing to confirm that the unit is in the pairing mode</p>

STEP 3. Install HPAV IP522CG and DLC-200C AC-to-PoE Power Supply.

Action	Illustration(s)
<ol style="list-style-type: none"> 1. At the installation location for the DLC-200C cabinet plug the IP522CG into the AC power outlet. 2. Observe LEDs on the front of the IP522CG. <ul style="list-style-type: none"> • The green POWER LED should be SOLID. 3. Mount the DLC-200 AC-to-PoE Power Supply on the wall adjacent to the AC power outlet <p>NOTE: DO NOT connect the IP522CG and DLC-200 AC to PoE Power Supply to an AC power outlet that is controlled by a switch.</p> 4. Install a Cat5/6 cable from the LAN port on the DLC-200 AC-to-PoE Power Supply to the RJ45 jack at the bottom of the IP522G. 5. Plug the AC power cord from the DLC-200 AC-to-PoE Power Supply into the AC wall outlet. 6. Create a Service Loop and use wall clamps to attach the power cord to the wall. 7. Observe LEDs on the front of the IP522CG. <ul style="list-style-type: none"> • The green POWER LED should be solid • The green Ethernet LED should be solid 	 <p>The illustration shows two parts. The top part shows the IP522CG device, a white rectangular unit with a power outlet at the top and a RJ45 port at the bottom. The bottom part shows the DLC-200C AC-to-PoE Power Supply, a black rectangular unit with an AC power cord and a service loop. The AC power cord is plugged into the power outlet of the IP522CG. The service loop is a loop of wire that is attached to the wall with clamps to prevent the power cord from being disconnected.</p> <p>NOTE: To prevent the PoE from accidentally being disconnected, create a Service loop and use two (2) or more clamps to attach the Service Loop to the wall.</p>

STEP 4. Install the Ethernet Power Adapter (IP522CG).

Action
Locate the customer's Broadband Home Router (BHR) and plug the IP522CG into an AC power outlet.
NOTE: Both the Power and PLC Link LEDs should illuminate on the IP522CG with the Power LED solid green and the PLC Link LED blinking green.

STEP 5. Observe LEDs.

Action
Observe the two LEDs on the IP522CG and the green Power LED and green PLC Link LED should illuminate confirming the there is a HPAV network connection over the in-home electrical wiring system between the IP522CG at the location of the DLC-200C cabinet and the IP522CG at the BHR.

STEP 6. Establish Ethernet Connection to Customer's BHR.

Action
Install an ANSI/TIA/EIA-568B Compliant Cat5/Cat6 Ethernet cable between the IP522CG and a port on the customer's BHR.

STEP 7. Observe LEDs.

Action
All three (3) green LEDs on the IP522CG should be illuminated indicating that the IP522CG has an Ethernet connection to the customer's BHR and there is a HPAV network connection over the in-home electrical wiring system between the IP522CG and the IP522CG at the DLC-200C cabinet. The Power LED should be solid green, the PLC Link should be flashing green and the Ethernet LED should be flashing green.

STEP 8. Return to location of DLC-200C cabinet.

5.7 Digital Life Controller Cabinet (DLC-200C) Installation

The DLC-200C should be wall mounted in a closet, utility room or basement similar to a traditional home security cabinet and adjacent to an AC power outlet. The cabinet is made of plastic and features a main cabinet door, a secondary battery backup door, five (5) System LEDs and a Jamming Sounder Silencing button. Figure 35 shows the DLC-200C cabinet fully assembled.

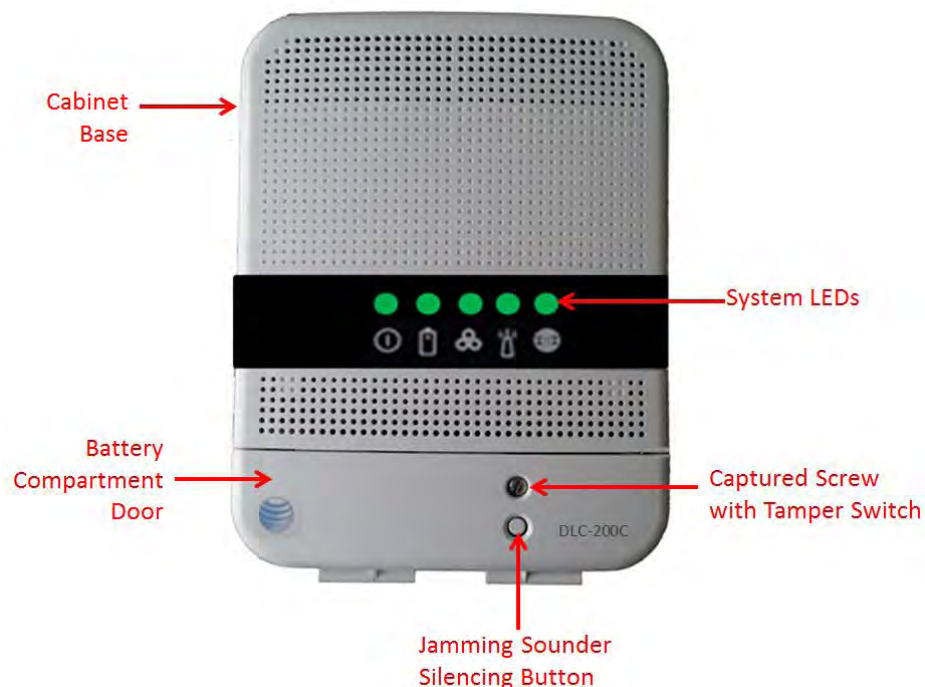

Figure 35: Digital Life Controller Cabinet (DLC-200C) with Identifiers



The System LEDs function as outlined below:



- ALL five (5) LEDs flash for one (1) second during the initial power up.
- AC POWER  —Flashing Green Indicates powering up; Green indicates DLC-200C is operational; OFF indicates Local Power Failure.

NOTE: The DLC-200C is operational when it starts communicating over AT&T Cellular Data Service and/or customer provided wireline broadband data service.

- 
BATTERY — **Flashing Green** indicates powering up; **Green** indicates the battery is installed; **Red** indicates the battery needs to be replaced; **OFF** indicates the battery is NOT installed.
- 
SYSTEM — (see table below)

LED	SYSTEM LED Behavior	
OFF	Initial Power-ON state	
Flashing Green	Indicates Powering Up	
Green	indicates system is good	
Red	<ul style="list-style-type: none"> Initial state when Digital Life Application (DLA) is running DLA has shutdown indicates there is some other system problem 	
Flashing yellow then flashing green	indicates Radio Frequency (RF) Jamming	
	Type of RF Jamming	SYSTEM LED Behavior
	One-Way 433 MHz Jamming at DLC-200C Cabinet	SYSTEM LIGHT blinks yellow once, blinks green once then repeats
	Two-Way 915 MHz Jamming at DLC-200C Cabinet	SYSTEM LIGHT blinks yellow once, blinks green twice then repeats
One-Way 433 MHz Jamming at a Signal booster (SW-ATT-RPTR4)	SYSTEM LIGHT blinks yellow once, blinks green three (3) times then repeats	

LED	SYSTEM LED Behavior	
	Two-Way 915 MHz Jamming at a Signal booster (SW-ATT-RPTR9)	SYSTEM LIGHT blinks yellow once, blinks green four (4) times then repeats
Yellow	<p>WARNING!</p> <p>If the SYSTEM LIGHT is flashing YELLOW then flashes GREEN repeating and an auditory signal is coming from the DLC-200C cabinet, the DLC-200C cabinet is detecting Radio Frequency (RF) Jamming. Please call 1-855-288-2727 for Technical Support.</p> <p>indicates the system is in Maintenance Mode.</p> <p>NOTE: The DLC-200C is in Maintenance Mode when software is being installed.</p>	

- 
WIRELESS BROADBAND — **OFF** indicates no cellular connection; **GREEN** Indicates good cellular connection and DLA is communicating with Digital Life Network Platform; **Flashing GREEN** or **YELLOW** indicates a good cellular connection with IP address from the cell tower; **RED** indicates weak cellular connection with IP address from the cell tower.
- 
WIRELINE BROADBAND — **OFF** indicates no broadband connection; **GREEN** Indicates broadband connection and DLA is communicating with Digital Life Network Platform; **Flashing GREEN** or **YELLOW** indicates broadband connection and an IP address from the customer's broadband home router.

NOTE: Under local power failure condition the BATTERY, SYSTEM and WIRELESS BROADBAND LEDs will flash simultaneously and WIRELINE BROADBAND data service will not be operating.

5.8 Installing the Digital Life Controller Cabinet (DLC-200C)

Prior to mounting the DLC-200C you must disassemble the unit to remove the mounting plate.

5.8.1 Disassemble the DLC-200C

STEP 1. Remove the mounting plate from the DLC-200C base unit..

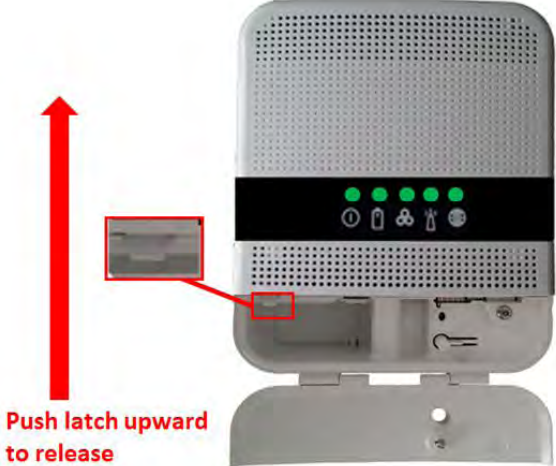
Action
<p>Remove the DLC-200C from its packaging and loosen the screw located on the front of the unit. Pull the battery door downward. Locate the latch on the upper left of the unit and push upward. Slide the DLC-200C base from the mounting plate. Place the base in a dry and secure location.</p>

5.8.2 Select the Mounting Location

STEP 2. Select and mark the mounting location.

Action
<p>Select a location to mount the DLC-200C (preferably in a closet, basement, or utility room). Locate a stud, if possible, and mark the location with a pencil.</p>

5.8.3 Digital Life Controller (DLC-200C) Cabinet Installation on a Sheetrock Wall

After you have located the best place to mount the DLC-200C cabinet, you may mount the DLC-200C cabinet to either a sheetrock wall or wall with open studs.

Follow these instructions to install the DLC-200C cabinet on a sheetrock wall:

STEP 3. Install the wall mounting plate on the sheetrock wall.

Action

Use the wall mounting plate as a template and mark the four (4) outermost or outside mounting holes (top/bottom) with a pencil.

NOTE: You may also mark the Wire Access Hole located in the middle right of the mounting plate. This will allow you to locate the area to feed all wires during the DLC-200C wiring process.

Figure 36: Cabinet Installation on a Sheetrock Wall

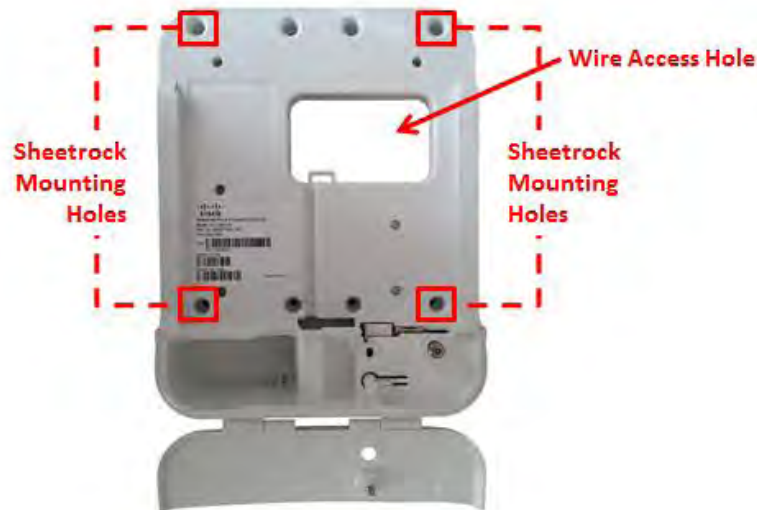

Pre-drill starter holes using an appropriate size masonry/wood bit. Use four (4) screws to mount the plate to a sheetrock wall by screwing into a stud for support.

NOTE: At least two (2) of the screws should be on a stud, if at all possible. Use the wall mounting anchors to secure the DLC-200C to a wall when no stud exists. Make sure that the mounting location is near an AC Power outlet.

5.8.4 DLC-200C Cabinet Installation on a Wall with Open Studs

After you have located the best place to mount the DLC-200C cabinet, you may mount the DLC-200C cabinet to either a sheetrock wall or wall with open studs.

Follow these instructions to install the DLC-200C cabinet on a wall with open studs:

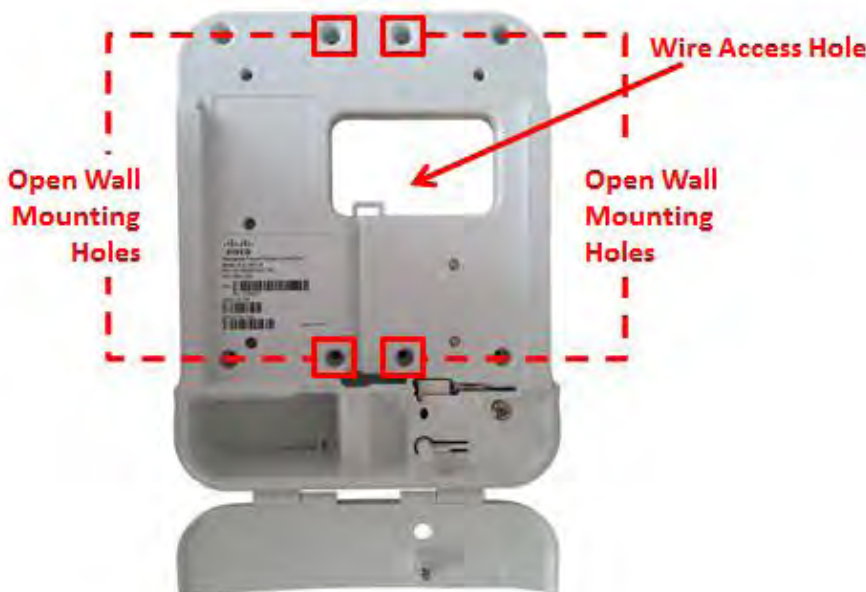

STEP 4. Mount the DLC-200C cabinet to a wall with open studs.

Action
<p>Use the mounting plate as a template and mark the four (4) innermost or center mounting holes (top/bottom) with a pencil.</p> <p>NOTE: You may also mark the Wire Access Hole located in the middle right of the mounting plate. This will allow you to locate the area to feed all wires during the DLC-200C wiring process.</p> <p style="text-align: center;">Figure 37: DLC-200C Cabinet Installation on an Open Wall</p>  <p>The diagram shows the back of the DLC-200C cabinet. Four red squares are drawn around the mounting holes: two on the top edge and two on the bottom edge. A red arrow points to a hole on the right side labeled 'Wire Access Hole'. Dashed red lines form a rectangular outline around the cabinet's back panel, with labels 'Open Wall Mounting Holes' on the left and right sides.</p> <p>Pre-drill starter holes using an appropriate size masonry/wood bit. Use four (4) screws to mount the plate to an open wall by screwing into a stud for support.</p> <p>NOTE: At least two (2) of the screws should be on a stud, if at all possible. Make sure that the mounting location is near an AC Power outlet.</p>

5.8.5 Wiring the Digital Life Controller (DLC-200C)

Follow these instructions to wire the DLC-200C:

STEP 5. Wiring the WAN Port

Action	
	<p>Measure the Ethernet cable to the width of the cradle or mounting plate. Feed the cable through the wire-run and insert the excess cable into the wire-cove located directly below the ports on the DLC-200C base.</p> <p>Figure 38: DLC-200C Mounting Plate Wire Runs</p> <p>Make sure that the Ethernet cable connector is exposed and facing forward. Align the base with the base-runs located on the front of the mounting plate. Slide the DLC-200C base approximately $\frac{1}{2}$ the way downward. Connect the Ethernet cable to base WAN port located center-left directly above the cable.</p>
<p>Make sure that the Ethernet cable connector is exposed and facing forward. Align the base with the base-runs located on the front of the mounting plate. Slide the DLC-200C base approximately $\frac{1}{2}$ the way downward. Connect the Ethernet cable to base WAN port located center-left directly above the cable.</p> <p>Figure 39: DLC-200C WAN Port Connection</p>	
<p>Lastly, plug the PoE Ethernet cable into the AC to Poe Power Supply (Microsemi[®] PowerDsine[™] 9001GR power supply).</p>	

5.8.6 Mount the DLC-200C Cabinet to the Wall Mounting Plate

Follow these instructions to mount the DLC-200C:

STEP 6. Mount the DLC-200C cabinet on the wall mounting plate.

Action
Slide the DLC-200C base downward until it snaps or latches to the wall mounting plate. Check the latch located to the far-left of the wall mounting plate to ensure that the unit is secure. Tighten the interior captured wall mounting screw to secure the cabinet to the wall mounting plate, as shown in Figure 40.

Figure 40: Mounting DLC-200C on the Wall Mounting Plate

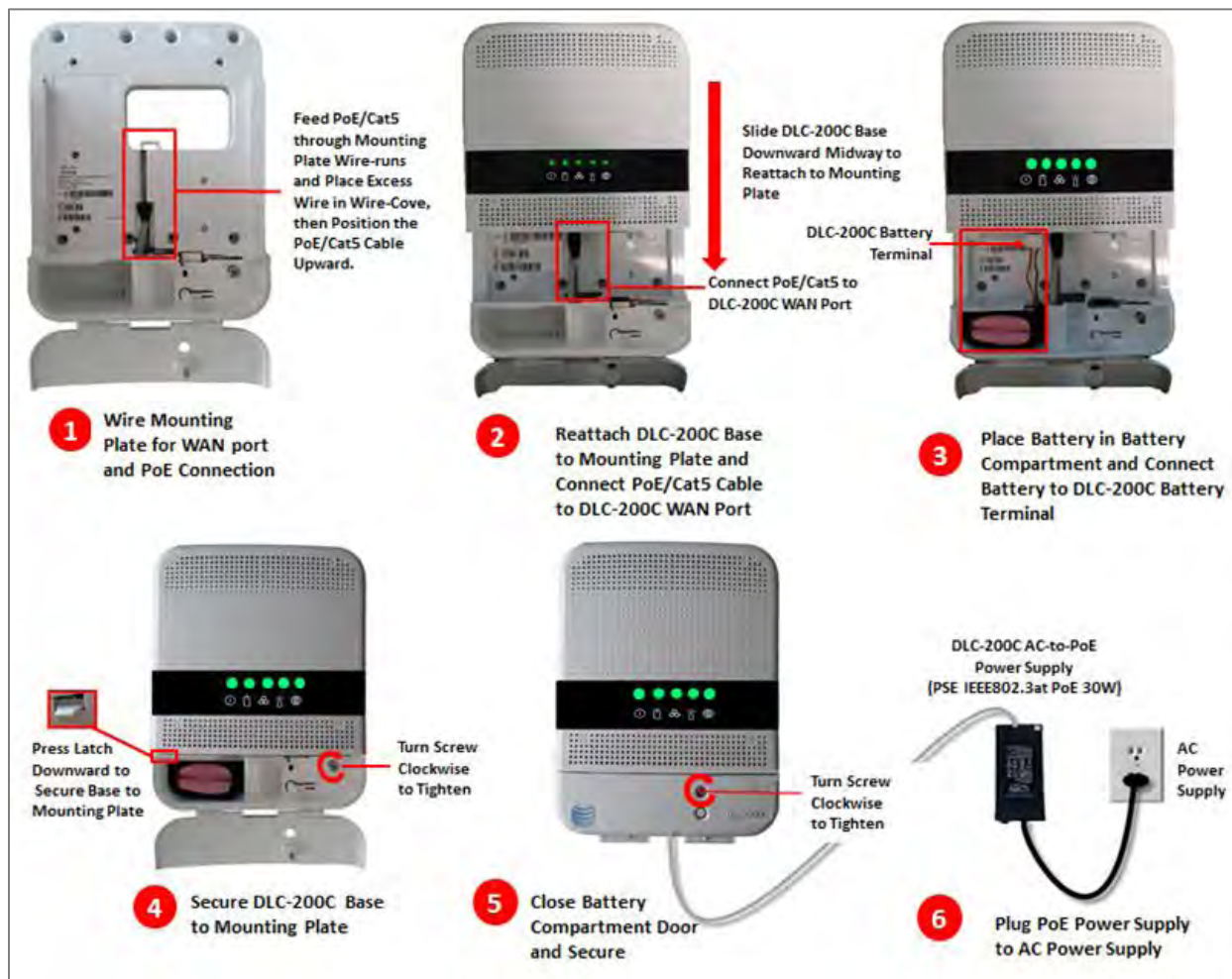

5.8.7 Install the Battery

The DLC-200C is shipped with one (1) rechargeable Li-ion battery pack. When you remove the battery pack from the packaging,

The battery compartment is located on the front of the DLC-200C cabinet, as shown in **Error! Reference source not found.**

Figure 41: Battery Compartment—Front Panel



NOTE: You can install the battery without disconnecting the AC power source.

Follow these steps to install the DLC-200C cabinet battery pack:





STEP 7.1. Install battery pack.

Action	Device/Illustration
<ol style="list-style-type: none"> Place the battery pack into the battery compartment located on the lower-left of the wall mounting plate. Feed the connector through the wire-run and attach the battery terminal to the DLC-200C battery connector. Snap to secure. <p>NOTE: The battery terminal MUST snap to secure. If the battery pack terminal DOES NOT snap, or latch, the battery pack is not properly installed.</p>	 <p style="text-align: center;">DLC-200C Battery Connection</p>

STEP 7.2. Secure battery pack and close.

Action	Device/Illustration
<ol style="list-style-type: none"> Tuck the battery pack leads securely within the battery compartment and slide the DLC-200C base downward until it snaps or latches. Lift the battery compartment door upward and tighten the captured screw to secure. 	 <p style="text-align: right;">Turn Clockwise to Tighten</p>

5.8.8 Observe System LEDs Function

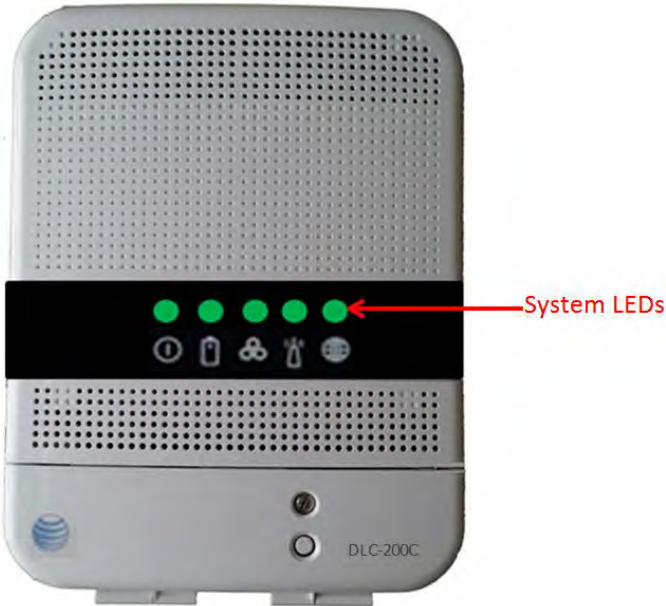
Action
<p>The System LEDs should start functioning as indicated:</p> <ul style="list-style-type: none"> • AC POWER  — Flashing Green indicates powering up; Green indicates DLC-200C is operational • BATTERY  - Green indicates the battery is installed • SYSTEM  — Green indicates that the system is good • WIRELESS BROADBAND  - Green indicates cellular connection • WIRELINE BROADBAND  — Green indicates cellular connection
<p style="text-align: center;">Figure 42: System LEDs Operational Indicators</p> 
<p>NOTE: For System LED behavior other than indicated, refer to Section 2: Digital Life Controller (DLC-200C) System LED Functions for clarification.</p>

5.8.9 Specifications—Digital Life Controller (DLC-200C)

Specifications-Digital Life Controller (DLC-200C)	
AT&T Model Number	DLC-200C
Operating Frequencies	<ul style="list-style-type: none"> • 433.92 MHz (Proprietary) • 911.78 MHz - 919.78 MHz (Proprietary) • 908 MHz (Z-Wave) • 1900 MHz (UMTS Band 2) • 850 MHz (UMTS Band 5) • 2.4 GHz (Wi-Fi)
Operating Environment	Temperature: 14°-113°F (10° to 45°C) Relative Humidity: 5% - 75% (non-condensing)
Dimensions	8.5"W x 11"H x 3.2"D
Radio Frequency Jamming Sounder with Switch	Located on the DLC-200C Cabinet Battery Door

5.8.10 Specifications—Digital Life Controller (DLC-200C) Battery

Specifications—Battery	
Required Batteries	One (1) battery pack
Battery Type	Rechargeable Li-Ion Battery Pack
Manufacturer	Cisco
Battery Model #	DLC-200 Battery
Battery Voltage	7.4VDC
Rated Capacity	9Ahr

5.8.11 Specifications—Digital Life Controller (DLC-200C) Battery Circuit Ratings

Specifications— Digital Life Controller (DLC-200C) Battery Circuit Ratings	
Charge Voltage	8.4VDC
Charge Current	375mA
Standby Time	Minimum 24 hours and 4 minutes

5.8.12 Specifications—Digital Life Controller (DLC-200C) Ethernet Cable Properties

Specifications— Digital Life Controller (DLC-200C) Ethernet Cable Properties	
Cat5 /Cat6	ANSI/TIA/EIA-568-B Compliant

5.9 Microsemi PD-9001GR/AT/AC Power over Ethernet (PoE) Installation

The Microsemi[®] PD-9001GR/AT/AC PoE converts AC Power to 55VDC power, which is delivered to the DLC-200 via a PoE/Cat5 cable interface. The Microsemi[®] PD-9001GR/AT/AC PoE supports up to 10/100/1000Mbps pass through data rates. The Single port PD-9001GR/AT/AC PoE can be powered via universal AC input and can provide up to 30W (see Figure 43).

Figure 43: Microsemi[®] PD-9001GR/AT/AC PoE Front Panel



The Microsemi[®] PD-9001GR/AT/AC PoE is equipped with the following :

- DATA & POWER OUT PORT
- DATA IN
- PORT CONNECTIVITY INDICATOR

(See Figure 44 for PoE Data Ports and Port Connectivity Indication)

Figure 44: Microsemi. PD-9001GR/AT/AC PoE Data Ports and Port Connectivity Indicator

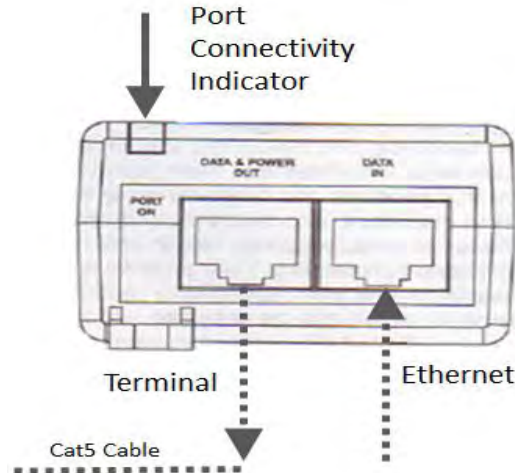

The PoE Port Connectivity Indicator functions as follows:

Port LED	Indicated Behavior
Yellow On	Power is ON (Power is Active)
Green On	Remote terminal is connected
Green (Blinking)	Overload State or Short-Circuit

5.9.1 Verifying Power to the Microsemi. PD-9001GR/AT/AC PoE

Follow these steps to install to the Microsemi. PD-9001GR/AT/AC PoE:

STEP 1. Verify that PoE is Operational.

Action
<p>Apply AC Power to the Microsemi. PD-9001GR/AT/AC PoE, using an operational AC cable with an appropriate ground connection. Connect an output PoE/Cat5 cable to the DATA & Power Out port and to the WAN port on the DLC-200C.</p> <p>WARNING: DO NOT USE CROSS OVER CABLE BETWEEN THE PD-9001GR/AT/AC OUTPUT PORT AND THE DLC-200C.</p>

5.9.2 Select the Mounting Location

The Microsemi[®] PD-9001GR/AT/AC PoE **must** be wall or stud mounted.

Follow these steps to mount to the Microsemi[®] PD-9001GR/AT/AC PoE to a sheetrock wall:

STEP 2. Select and mark the mounting location.

Action

Select a location to mount the PD-9001GR/AT/AC PoE. (Preferably in a closet, basement, or utility room). Locate a stud, if possible, use the Microsemi[®] PD-9001GR/AT/AC PoE as a template and mark the location with a pencil.

NOTE: Select a location near an AC Power Outlet within the proximity of the DLC-200C.

5.9.3 Mounting the Microsemi[®] PD-9001GR/AT/AC PoE to the Wall

Follow these steps to mount the Microsemi[®] PD-9001GR/AT/AC PoE to the wall:

STEP 3. Mount the Microsemi[®] PD-9001GR/AT/AC PoE.

Action

Pre-drill starter holes using an appropriate size masonry/wood bit. Use two (2) screws to mount the Pd-9001GR/AT/AC to a wall or stud.

Flip the PD-9001GR/AT/AC PoE upside down so that the data ports are facing upward and align the PD-9001GR/AT/AC PoE with the pre-drilled holes, then insert screws and tighten.

NOTE: Make sure that the PD-9001GR/AT/AC is mounted in an area free from vibration, dust and debris. Ensure that airflow to the PD-9001GR/AT/AC is not blocked and that the PD-9001GR/AT/AC is installed away from excessive heat and humidity.

5.9.4 Connect the PD-9001GR/AT/AC PoE to an AC Power Outlet

STEP 4. Connect the PD-9001GR/AT/AC to the DLC-200C via PoE/Cat5 cable.

Action

The PoE/Cat5 cable must be **no greater than** 330 feet (100 meters) in length. Using a standard power cord plug the PD-9001GR/AT/AC PoE into an AC power outlet (100-240 VAC).

NOTE: The PoE is not a repeater and does not amplify the Ethernet data signal.

WARNING: DO NOT connect the DLC-200 US to an AC power outlet that is controlled by a switch or on a GFCI circuit.

5.9.5 Connect PD-9001GR/AT/AC PoE to the DLC-200C

STEP 5. Connect the PD-9001GR/AT/AC to the DLC-200C via PoE/Cat5 Cable.

Action

Connect the DATA & POWER OUT via PoE/Cat5 cable to the WAN port on the DLC-200C.

5.9.6 Troubleshooting the Microsemi[®] PD-9001GR/AT/AC PoE

If the PD-9001GR/AT/AC PoE does not power up, do one or more of the following:

- Verify that a reliable power cord is used.
- Verify that the voltage at the power inlet is between 100 and 240 VAC.
- Remove and re-apply power to the PD-9001GR/AT/AC and check the indicator during the power up sequence.

If the PD-9001GR/AT/AC does not operate, do one or more of the following:

- Verify that you are using a standard Cat5 straight-wired Cat5 cable with four (4) pairs rather than a cross-over wired Cat5 cable.
- Ensure input Ethernet/Cat5 cable is connected to the DATA IN port.

- Verify that the PD-9001GR/AT/AC DATA & POWER port is connected via a PoE/Cat5 cable to the WAN port on the DLC-200C.
- Reconnect the DLC-200C into a different PD-9001GR/AT/AC.
NOTE: If this works, there is probably a faulty port or RJ45 connection.
- Verify that there is not short over any of the twisted pair cables or over the RJ45 connectors.

The DLC-200C is receiving power, but there is no data link with the DLC-200C:

- Verify that the port indicator, located on the front panel, is continuously lit.
- Verify that for this link, you are using standard UTP/FTP Cat5 straight (non-crossover) cabling, with all four (4) pairs.
- Verify that the Ethernet cable length is less than 330 feet (100 meters) from the Ethernet source to the load/remote terminal.
- Reconnect the DLC-200C to a different PD-9001GR/AT/AC.
NOTE: If this works, there is probably a faulty port or RJ45 connection.

5.9.7 Specifications (Environmental)— Microsemi. PD-9001GR/AT/AC PoE (PoE)

Specifications (Environmental)—PD-9001GR/AT/AC Power over Ethernet (PoE)	
Model Number	PD-9001GR/AT/AC
Manufacturer	Microsemi®
Operating Environment	Temperature: 32° to 104°F (0° to 40°C) Relative Humidity: 10 -85%, non-condensing
Storage	Temperature: -4 to 158°F (-20° to 70°C) Relative Humidity: 10 -85%, non-condensing

5.9.8 Specifications (Electrical)— Microsemi. PD-9001GR/AT/AC PoE (PoE)

Specifications (Electrical)—PD-9001GR/AT/AC Power over Ethernet (PoE)	
Input Voltage	100 – 240 VAC (50/60 Hz)
Maximal Input Current	.08 Ampere
Available Output Power (max)	30 Watts
Nominal Output Voltage	55 VDC

5.9.9 Specifications (Ethernet Interface)— Microsemi. PD-9001GR/AT/AC PoE (PoE)

Specifications (Ethernet Interface)— PD-9001GR/AT/AC Power over Ethernet (PoE)	
Input (DATA IN): Ethernet 10/100/1000Base-T	RJ45 Female Socket
Output (DATA & POWER OUT): Ethernet 10/100/1000Base-T, plus 55 VDC	RJ45 Female Socket, with DC Voltage on Wire Pairs, 4 - 5 (+) & 7 - 8

5.10 PHIHONG POE31U-1AT Power over Ethernet (PoE) Installation

The PHIHONG^{XQP} POE31U-1AT PoE converts AC Power to 56VDC power via an Ethernet cable. The PHIHONG^{XQP} POE31U-1AT PoE supports up to 10/100/1000Mbps pass through data rates. The Single Port PHIHONG^{XQP} POE31U-1AT PoE can be powered via universal AC input and can provide up to 30W Passive Power (see Figure 45).

Figure 45: PHIHONG^{XQP} POE31U-1AT PoE Front Panel



The PHIHONG^{XQP} POE31U-1AT PoE is equipped with the following:

- POWER “OUT” PORT
- DATA “IN” PORT
- “STATUS” CONNECTIVITY INDICATOR

Figure 46: PHIHONG^{XQP} POE31U-1AT PoE Data Ports and Status Connectivity Indicator

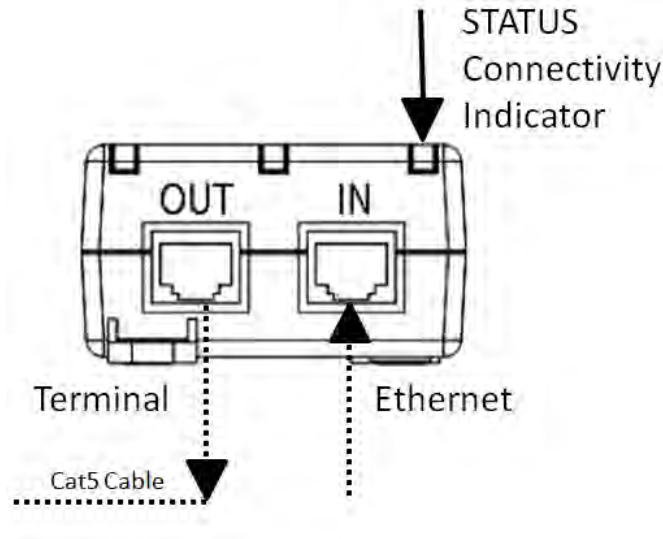

The PoE Status Connectivity Indicator functions as follows:

Port LED	Indicated Behavior
Solid GREEN	Valid IEEE802.3at load detected and connected "ON"
Blinking GREEN	Power "ON" ready for connection
Blinking RED/GREEN	Invalid load connected
Blinking RED	FAULT

5.10.1 Verifying Power to the PHIHONG^{XQP} POE31U-1AT PoE

Follow these steps to install to the PHIHONG^{XQP} POE31U-1AT PoE:

STEP 1. Verify that PoE is Operational.

Action

Apply AC Power to the PHIHONG^{XQP} POE31U-1AT PoE, using an operational AC cable with an appropriate ground connection. Connect an output Ethernet cable to the OUT port. Verify that a power ready Ethernet compatible device is

Action

connected.

WARNING: DO NOT USE CROSS OVER CABLE BETWEEN THE PHIHONG^{XQP} POE31U-1AT OUTPUT PORT AND THE LOAD DEVICE.

5.10.2 Select the Mounting Location

The PHIHONG^{XQP} POE31U-1AT PoE **must** be wall or stud mounted.

Follow these steps to mount to the PHIHONG^{XQP} POE31U-1AT PoE to a sheetrock wall:

STEP 2. Select and mark the mounting location.

Action

Select a location to mount the PHIHONG^{XQP} POE31U-1AT PoE. (Preferably in a closet, basement, or utility room). Locate a stud, if possible, use the PHIHONG^{XQP} POE31U-1AT PoE as a template and mark the location with a pencil.

NOTE: Select a location near an AC Power Outlet within the proximity of the DLC-200CEU.

5.10.3 Mounting the PHIHONG^{XQP} POE31U-1AT PoE to the Wall

Follow these steps to mount the PHIHONG^{XQP} POE31U-1AT PoE to the wall:

STEP 3. Mount the PHIHONG^{XQP} POE31U-1AT PoE.

Action

Pre-drill starter holes using an appropriate size masonry/wood bit. Use two (2) screws to mount the PHIHONG^{XQP} POE31U-1AT to a wall or stud.

Flip the PHIHONG^{XQP} POE31U-1AT PoE upside down so that the data ports are facing upward and align the PHIHONG^{XQP} POE31U-1AT PoE with the pre-drilled holes, then insert screws and tighten.

NOTE: Make sure that the PHIHONG^{XQP} POE31U-1AT is mounted in an area free

Action

from vibration, dust and debris. Ensure that airflow to the PHIHONG^{XQP} POE31U-1AT is not blocked and that the PHIHONG^{XQP} POE31U-1AT is installed away from excessive heat and humidity.

5.10.4 Connect the PHIHONG^{XQP} POE31U-1AT PoE to an AC Power Outlet

STEP 4. Connect the PHIHONG^{XQP} POE31U-1AT to the DLC-200CEU via Ethernet Cable.

Action

Using a standard power cord plug the PHIHONG^{XQP} POE31U-1AT into an AC power outlet (100-240VAC).

NOTE: The PoE is not a repeater and does not amplify the Ethernet data signal.

WARNING: DO NOT connect the DLC-200CEU to an AC power outlet that is controlled by a switch or on a GFCI circuit.

5.10.5 Connect PHIHONG^{XQP} POE31U-1AT PoE to the DLC-200CEU

STEP 5. Connect the PHIHONG^{XQP} POE31U-1AT to the DLC-200CEU via Ethernet Cable.

Action

Connect the IN port Ethernet/Cat5 cable to the WAN port on the DLC-200CEU.

5.10.6 Troubleshooting the PHIHONG^{XQP} POE31U-1AT PoE

If the PHIHONG^{XQP} POE31U-1AT PoE does not power up, do one or more of the following:

- Verify that a reliable power cord is used.
- Verify that the voltage at the power inlet is between 100 and 240 VAC.

- Remove and re-apply power to the PHIHONG^{XQP} POE31U-1AT and check the indicator during the power up sequence.

If the PHIHONG^{XQP} POE31U-1AT does not operate, do one or more of the following:

- Verify that you are using a standard Cat5 straight-wired cable with four (4) pairs.
- If an external power splitter is in use, replace it with a known good splitter.
- Ensure input Ethernet cable is connected to the IN port.
- Verify that the PHIHONG^{XQP} POE31U-1AT is connected to the DATA & POWER port.
- Reconnect the DLC-200CEU into a different PHIHONG^{XQP} POE31U-1AT.

NOTE: If this works, there is probably a faulty port or RJ45 connection.

- Verify that there is not short over any of the twisted pair cables.

The end device operates, but there is no data link:

- Verify that the Status indicator, located on the front panel, is continuously lit.
- If an external power splitter is in use, replace it with a known-good splitter.
- Check the Ethernet cable length from the Ethernet source to the load/remote terminal.
- Reconnect the DLC-200CEU to a different PHIHONG^{XQP} POE31U-1AT.

5.10.7 Specifications (Environmental)— PHIHONG^{XQP} POE31U-1AT PoE (PoE)

Specifications (Environmental)— PHIHONG ^{XQP} POE31U-1AT Power over Ethernet (PoE)	
Model Number	POE31U-1AT
Manufacturer	PHIHONG ^{XQP}
Operating Environment	Temperature: 0° to 40°C Relative Humidity: 20 -90%
Non-Operating Environment	Temperature: -25° to 65°C)

5.10.8 Specifications (Electrical)— PHIHONG^{XQP} POE31U-1AT PoE (PoE)

Specifications (Electrical)— PHIHONG ^{XQP} POE31U-1AT Power over Ethernet (PoE)	
Input Voltage	90 to 264VAC/60Hz
Maximal Input Current	.08Ampere (RMS) maximum for 120VAC .05Ampere (RMS) maximum for 240VAC
Available Output Power (max)	30 Watts
Nominal Output Voltage	56V
Output Current	0.54A

6 Device Installation, Discover, Registration and Operation

6.1 *FCC Regulations*²

The following FCC Regulations apply to most, if not all, 915 MHz and 433 MHz devices:

This device complies with part 15 of the FCC Rules. Operation is subject to the following two conditions: (1) This device may not cause harmful interference, and (2) this device must accept any interference received, including interference that may cause undesired operation.

This device has been tested and found to comply with the limits for a Class B digital device, pursuant to Part 15 of the FCC Rules. These limits are designed to provide reasonable protection against harmful interference in a residential installation. This equipment generates uses and can radiate radio frequency energy and, if not installed and used in accordance with the instructions, may cause harmful interference to radio communications. However, there is no guarantee that interference will not occur in a particular installation. If this equipment does cause harmful interference to radio or television reception, which can be determined by turning the equipment off and on, the user is encouraged to try to correct the interference by one or more of the following measures:

- Reorient or relocate the receiving antenna.
- Increase the separation between the equipment and receiver.
- Connect the equipment into an outlet on a circuit different from that to which the receiver is connected.
- Consult the dealer or an experienced radio/TV technician for help.

Changes or modifications not expressly approved by the party responsible for compliance could void the user's authority to operate the equipment.

The antenna(s) used for this transmitter must not be co-located or operating in conjunction with any other antenna or transmitter.

6.1.1 RF Exposure Information

This device meets the government's requirements for exposure to radio waves.

This device is designed and manufactured not to exceed the emission limits for exposure to radio frequency (RF) energy set by the Federal Communications Commission of the U.S. Government.

This device complies with FCC radiation exposure limits set forth for an uncontrolled environment. In order to avoid the possibility of exceeding the FCC radio frequency exposure limits, human proximity to the antenna shall not be less than 20cm (8 inches) during normal operation.

6.1.2 Important Information About Radio Devices

The following information is important when installing radio (wireless) devices:

1. AT&T radio controls provide a reliable communications link and fill an important need in portable wireless signaling. However, there are some limitations which must be observed.
2. For US installations only: the radios are required to comply with FCC rules and regulations including FCC part 15 devices. As such, they have limited transmitter power and therefore limited range.
3. A receiver cannot respond to more than one transmitted signal at a time and may be blocked by radio signals that occur on or near their operating frequencies regardless of code settings.
4. Changes or modifications to the device may void FCC compliance
5. Infrequently used radio links should be tested regularly to protect against undetected interference or fault.
6. RF signals can be affected by metal objects including metal doors or large mirrors. Care should be taken to avoid these objects during installation as they can interfere with proper operation.

6.1.3 FCC Compliance Statement

The following is the FCC Compliance Statement as it applies to UL Certification:



This device complies with FCC Rules and Regulations as Part 15 devices as well as Industry Canada Rules and Regulations. Operation is subject to the following two (2) conditions:

- This device may not cause harmful interference.
- This device must accept any interference received, including
- interference that may cause undesired operation.

WARNING:

The polarity of the battery must be observed. Improper handling of lithium batteries may result in heat generation, explosion or fire which may lead to personal injuries. Replace only with the same as recommended by the manufacturer. Use of another battery may present a risk of fire or corrosion.

CAUTION:

Batteries should not be recharged, disassembled, in heat above 100°C (212°F) or disposed of in fire.

Disposal of used batteries must be made in accordance with the waste recovery and recycling regulations in your area.

Notice to users in California—This Perchlorate warning applies only to Manganese Dioxide Lithium cells sold or distributed only in California, USA. Perchlorate Material special handling may apply.

See www.dtsc.ca.gov/hazardouswaste/perchlorate.

6.2 915 MHz Products

The 915 MHz devices feature proprietary two-way communication with the Digital Life Controller (DLC-200C). The 915 MHz devices are:

- Keypad (Model SR-KPD02)
- Keychain Remote (Model SW-ATT-FOB2)
- Indoor Siren (Model SW-ATT-SRN)
- Smoke Sensor (Model 562NSTT-OEM-ATT01)
- Signal Booster (915) (Model SW-ATT-RPTR9)
- Conversion Kit (Model SW-ATT-TAKRFV2)
- Device Controller (Model SW-ATT-DC) (Supplementary use only. Not part of the fire and security system.)

Approximately once every twenty minutes 915 MHz devices automatically transmit supervisory messages to the DLC-200C. These supervisory messages are also known as heartbeat messages. These supervisory messages communicate the identity of the device, the status of the device and the battery level, if the device is equipped with a battery. If the DLC-200C does not receive three consecutive supervisory messages from a 915 MHz device, then the device is considered to be offline and an advisory message is automatically sent to the AT&T Digital Life Central Monitoring Center.

WARNING! DO NOT connect any 915 MHz corded product to an AC power outlet that is controlled by a switch to ensure that the product receives continuous power.

6.2.1 Keypad (Model SR-KPD02) (915 MHz)

The Keypad (Model SR-KPD02) is a proprietary 915 MHz wireless keypad that enables control of all system functions. It is a compact unit that can only be wall mounted, and includes the following features:

- LCD with three (3) line, sixteen (16) character per line display
- LCD and keypad backlight with brightness control that is user adjustable via the numeric keypad.
- Three (3) Function buttons used to control arming of the intrusion system. From top to bottom, the buttons are labeled as: AWAY, STAY and INSTANT.

NOTE: If the Armed (Red) LIGHT is ON, a LCD message will indicate the status of the System: Armed – Away, Armed – Stay or Armed - Instant. If the Ready (Green) LIGHT is ON, the system is ready for arming. If the Armed (Red) LIGHT is OFF and the Ready (Green) LIGHT is OFF, then the system is not ready for arming because one or more of the monitored devices, such a door or window, is not in the closed state

Keypad (Model SR-KPD02) is an ANSI/SIA CP-01 compliant device with CP-01-2010 administered features that support false alarm reduction. (For more information regarding CP-01-2010 Supported Features to False Alarm Reduction (*see, Section 12: CP-01-2010 Supported Features to False Alarm Reduction*)).

Keypad (Model SR-KPD02) also provides access to system operation, which includes the following functions:

- Arm-STAY
- Arm-AWAY
- INSTANT (Arm-STAY with no Exit Delay)
- BYPASS
- Disarm
- Fire Emergency
- Auxiliary Emergency
- Police Emergency

The customer must enter a four (4) digit Security PIN into the Keypad (Model SR-KPD02) in order to disarm the system. The customer creates the four (4) digit Security PIN using a Web tool (WWW.ATT.COM/DLPIN). Keypad (Model SR-KPD02) is depicted in Figure 47:

Figure 47: Keypad (Model SR-KPD02) Features

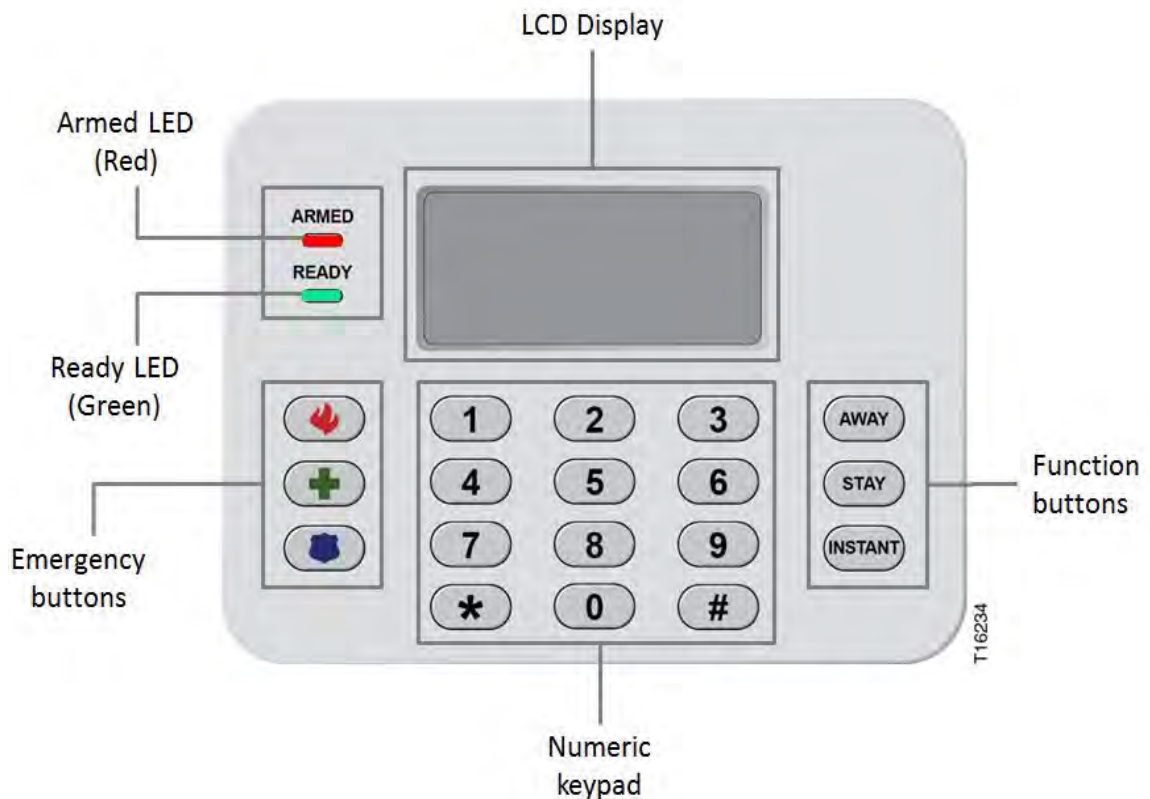

The LCD displays the current system state and any changes in system state. The Keypad (Model SR-KPD02) is powered by an AC/DC adapter (AmpowerTek AL12AA-00) that plugs into an AC power outlet. The Keypad (Model SR-KPD02) is equipped with four (4) NiMH (Nickel Metal Hydride) batteries that provide 24 hour battery backup under a local power failure condition. The batteries are customer installable.

Keypad (Model SR-KPD02) can only be mounted to the wall. The Keypad (Model SR-KPD02) is equipped with a tamper switch, which is located on the rear of the unit. If the system is armed and the keypad is removed from the wall, a tamper alarm will be generated and reported to the AT&T Digital Life Central Monitoring Center.

6.2.1.1 Keypad (Model SR-KPD02) Installation Kit

The Keypad (Model SR-KPD02) must be mounted on the wall and includes the following items for installation:

- One (1) Digital Life Basic Keypad
- Four (4) Rechargeable NiMH (Nickel Metal Hydride) Batteries
- One (1) Mounting Plate
- Four (4) 5/8" Wood Screws
- Four (4) Plastic Wall Anchors
- Two (2) Security Torx Screws
- One (1) AC/DC Power Adapter
- 22 AWG Wire (not included)
- 5/8" Phillips-head Screw Driver (not included)
- Torx Screw Driver (not included)

6.2.1.2 Installing the Keypad (Model SR-KPD02)

The Keypad (Model SR-KPD02) installation and/or replacement process includes the following:

1. Wiring the Mounting Plate
2. Attaching the Mounting Plate to the Wall
3. Installing/Replacing the Batteries
4. Charging the Batteries Before Discovering the Keypad (Model SR-KPD02) (*if applicable*)
5. Discovering/Registering the Keypad (Model SR-KPD02)

6. Attaching the Keypad (Model SR-KPD02) to the Wall

6.2.1.2.1 Wiring the Mounting Plate

Follow these steps to wire the mounting plate:

1. Select the location to mount the keypad (preferably an entrance/exit location).
2. Mark the mounting holes at the desired location and reattach the mounting plate to the keypad.
3. Take a measuring tape and measure the distance from the mounting holes to the AC power outlet.
4. Cut a piece of white 22 AWG wire the length of the measured distance. Strip approximately 2½" off the wire cover and approximately ½" off each lead.
5. Remove the mounting plate from the keypad and use a stud finder to locate the nearest stud.
6. Mark the mounting holes at the desired location. Reattach the mounting plate to the keypad.



NOTE: Use a pencil to mark the mounting holes

7. Take a measuring tape and measure the distance from the mounting holes to the AC power outlet.
8. Cut a piece of white 22 AWG wire the length of the measured distance. Strip approximately 2½" off the wire cover and approximately ½" off each lead.
9. Use a Phillips screwdriver and loosen the screws on the back of the mounting plate.
10. Connect the **red** lead to the positive (+) connector and the **black** lead to the negative (-) connector.

CAUTION: The color wire used for positive and negative leads may be different than stated above. To ensure a consistency in polarity, it is **VERY IMPORTANT** that you take note of the color and/or wire markings used for each connection.

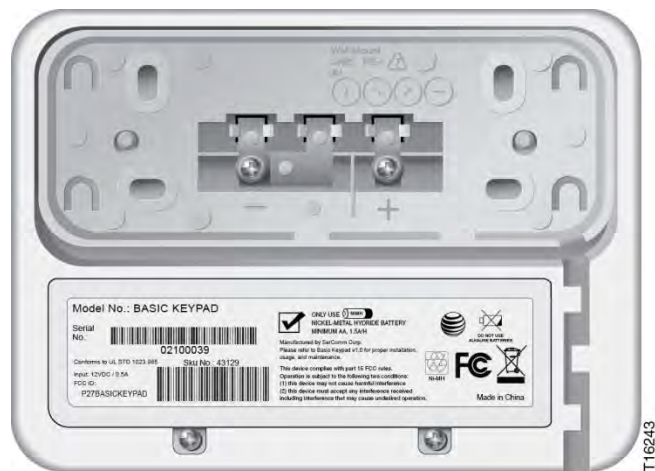

NOTE: The connector markings are located below its respective connector. The **Negative** connector is a dual connector that allows you to quickly distinguish between the connectors.

11. Use the Phillips screwdriver and tighten the connectors, then thread the wire through the routed wire-runs located on the rim of the mounting plate.



NOTE: The routed wire-runs are used to secure the wire.

6.2.1.2.2 Attaching the Mounting Plate to the Wall

Follow these steps to attach the mounting plate to the wall:

1. Pre-drill starter holes using the 5/8" masonry/wood drill bit, if applicable.
2. Hold the mounting plate against the wall and align the mounting holes on the mounting plate with the holes in the wall.
3. Place the four (4) wood mounting screws in the mounting holes and turn clockwise to tighten.

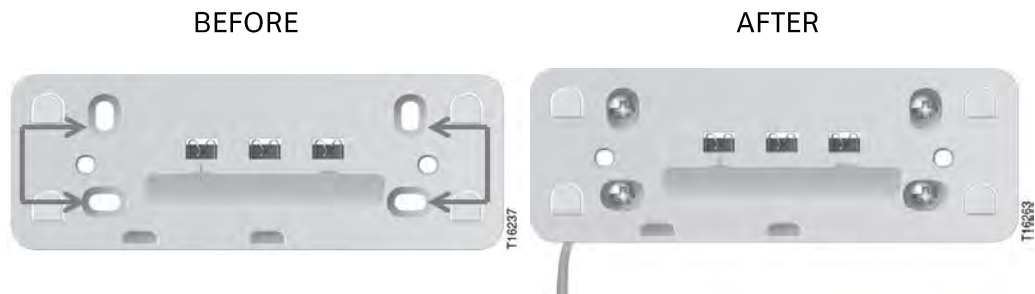

4. Connect the **red** lead to the positive (+) connector and the **black** lead to the negative (-) connector on the adapter.



NOTE: The connector markings are located in the middle indentation next to its appropriate connector.

WARNING! Cross wiring may damage the device. To avoid cross wiring, make sure that the color wire used for the positive lead is attached to the positive connectors on both the adapter and the mounting plate.

6.2.1.2.3 Installing/Replacing the Keypad (Model SR-KPD02) Batteries

The Keypad (Model SR-KPD02) has four (4) rechargeable NiMH (Nickel Metal Hydride) batteries that provide twenty-four (24) hour battery backup. The batteries can be replaced by opening the battery compartment located on the rear of the unit.

Follow these steps to install/replace the batteries:

1. Make sure that the system is disarmed before opening the battery compartment door to replace the batteries.
2. Remove the blue tape and use a Torx screwdriver to remove the battery compartment screws.
3. Remove the compartment cover and insert four (4) NiMH rechargeable batteries. Replace the compartment cover and tighten the screws.

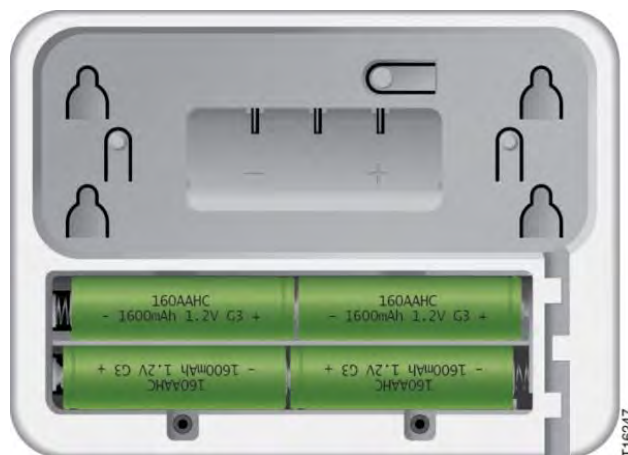

NOTE: Ensure to check the polarity of the batteries prior to installation. Under normal working conditions the rechargeable batteries will last over 24 hours before having to be recharged.

6.2.1.2.4 Charging the Batteries Before Discovering Keypad (Model SR-KPD02) (if applicable)

Follow these steps to charge the batteries:

1. Align the three (3) connector terminals on the keypad with the mounting plate terminal slots.
2. Slide the rear panel of the keypad downward onto the mounting plate. Snap the keypad into place and check the LCD for “Digital Life” display. Allow the batteries to charge for approximately ten (10) minutes.

6.2.1.2.5 Discovering/Registering the Keypad (Model SR-KPD02)

Follow these steps to discovery/register the Keypad (Model SR-KPD02):

1. Access Digital Life Direct (DLD) and select the DL Controller/Gateway, then select the **Devices** tab.
2. Click the **Start Discovery** button and wait until “Discovery in progress” displays.
3. Remove the mounting plate from the keypad.
4. Press and hold the **Learn** tab on the rear of the keypad for three (3) seconds.



5. Release the **Learn** tab (Discovery button). The LCD should display “Digital Life> Discovery Started.”

- Wait until the LCD displays “Digital Life>Discovery Success.” Click the **Stop Discovery** button in DLD.

NOTE: If the process fails the LCD will display “Discovery Failed.” Repeat Step 4-6 until “Discovery Success” is achieved.

6.2.1.2.6 Attaching the Keypad (Model SR-KPD02) to the Wall

Follow these steps to attach the Keypad (Model SR-KPD02) to the wall:

- Align the three (3) connector terminals on the keypad with the mounting plate terminal slots.



- Slide the rear panel of the keypad downward onto the mounting plate.

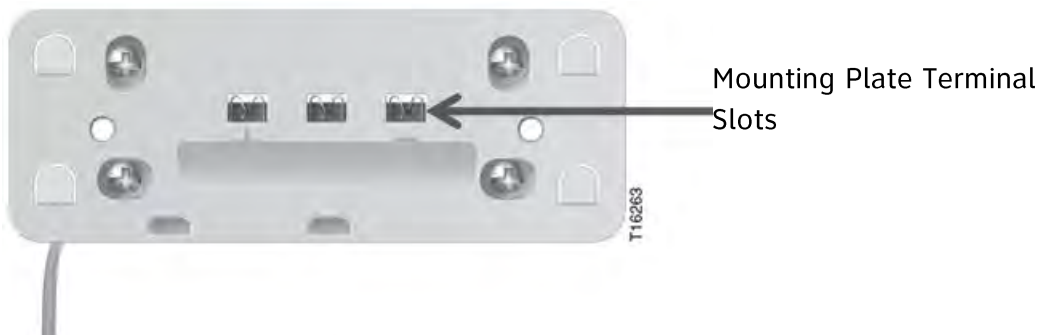

- Snap the keypad into place and check the LCD for “Digital Life” display. Remove the protective sheet from the LCD.

6.2.1.3 Keypad (Model SR-KPD02) Display and Sounding of Device Trouble Conditions

The DL Basic Keypad (Model SR-KPD02) displays messages and chirp whenever device trouble conditions exist. The user will be able to silence the chirping sound by pressing the pound (#) button on the keypad, but the display message will continue to be displayed as long as the trouble condition exists. The chirping sound is a 0.5 second tone every minute. Table 2 contains the device trouble condition messages that can appear in the keypad display. The chirping sound will automatically be silenced between 9:00PM to 9:00AM local time.

Table 2: Device Trouble Conditions, Keypad (Model SR-KPD02) Display Messages and Silence Chirping

Device Trouble Condition	Keypad Display Messages	Silence Chirping
Missing DLC-200C Battery or low DLC-200C battery	"Press # to Silence"	Press # button on keypad to silence chirping for four (4) hours
DLC-200C AC Power Fail	"System Operating Battery Backup" and "Press # to Silence"	Press # button on keypad to silence chirping for four (4) hours
Siren, Keypad, 915 MHz Repeater, 433MHz Repeater, Smoke Sensor, CO Sensor or Conversion Kit Low Battery	"<device name> Low Battery" and "Press # to Silence"	Press # button on keypad to silence chirping for four (4) hours
Keypad, Siren, 915 MHz Repeater, 433 MHz Repeater, Smoke Sensor, CO Sensor or Conversion Kit Offline	"<device name> Offline" and "Press # to Silence"	Press # button on keypad to silence chirping for four (4) hours
Door/Window Sensor, Glass Break Sensor or Motion	"<device name> Offline" and "Press # to Silence"	Press # button on keypad to silence forever

Device Trouble Condition	Keypad Display Messages	Silence Chirping
Sensor (PIR) Offline		
Door/Window Sensor, Glass Break Sensor, or Motion Sensor (PIR) Low Battery	"<device name> Low Battery" and "Press # to Silence"	Press # button on keypad to silence forever

6.2.1.4 Specifications—Keypad (Model SR-KPD02)

Specifications— Keypad (Model SR-KPD02)	
AT&T Model Number	SR-KPD02
Voltage Primary	Primary 120VAC, 60Hz, 48VA1 Secondary 16.5VAC, 60Hz, 2.42A
Required Batteries	4
Battery Type	Rechargeable, NiMH (Nickel Metal Hydride)
Projected Battery Life	36 months (3 years)
Operating Frequency	915 MHz
Open Air Wireless Signal Range	500 feet
Operating Environment	Temperature: 32°-120.2°F (0° to 49° C) Relative Humidity: 8%-85%, non-condensing Storage: -13°-158°F (-25°-70°C)
Aesthetics/Dimensions	Color: AT&T White Material: Plastic Size: 5-1/2 "Wx4-1/8"H

6.2.2 Keychain Remote (Model SW-ATT-FOB2)

The AT&T model number **SW-ATT-FOB2** is an encrypted four-button proprietary two-way 915 MHz keychain remote transmitter that features over 16 billion different encrypted code sequences and emits **RED** and **GREEN** flashes according to the task assigned. All buttons have been assigned a task within the DLS, as shown in Figure 48.

Figure 48: Keychain Remote (Model SW-ATT-FOB2)



Keychain Remote (Model SW-ATT-FOB2) Functions	
Button/Function	Action
Arm-AWAY	Arms the DLS when the home is unoccupied and typically arms door/window sensors, motion sensors and glass break sensors. The Keypad chirps on entry/exit delay.
Arm-STAY	Arms the DLS when someone is remaining in the home and typically arms door/window sensors and glass break sensors, but NOT the motion sensors. Exit delay is activated silently. Keypad chirps on Entry Delay.

AT&T Proprietary Information. All rights reserved.

Keychain Remote (Model SW-ATT-FOB2) Functions	
Button/Function	Action
Arm-INSTANT	Arms the DLS when someone is remaining in the home and typically arms door/window sensors and glass break sensors but NOT the motion sensors. Exit Delay is activated silently. There is no Entry Delay and an intrusion alarm is sent immediately.
Disarm	Disarms the intrusion portion of the DLS when the system is in any state, but DOES NOT cancel any alarm (intrusion, smoke, CO or emergency).

The Keychain Remote (Model SW-ATT-FOB2) is battery operated. Under normal operation when a button is pressed on the keychain remote, the LED at the top of the keychain remote will perform one of the following states during the transmission to the DLC-200C:

- DISARMING – the LED will flash GREEN for two (2) seconds, then illuminates solid GREEN for two (2) seconds.
- ARMING (with all sensors secure or closed) – the LED will flash GREEN for two (2) seconds, then illuminates solid RED for two (2) seconds.
- ARMING (with open sensor(s) bypassed) – the LED will alternate flashes (GREEN, RED, GREEN) for two (2) seconds then illuminate solid RED for two (2) seconds.

The keychain remote will perform one of the following states during a low battery transmission:

- DISARMED – When a button is pressed to ARM the system, then the LED will flash RED for two (2) seconds and no arming will occur.
- ARMED – When the button is pressed to DISARM the system, the LED will flash GREEN then illuminate solid GREEN during the transmission to the DLC-200C.

6.2.2.1 Replacing the Keychain Remote (Model SW-ATT-FOB2) Batteries

Batteries are installed in the Keychain Remote (Model SW-ATT-FOB2) during the production process. The Keychain Remote (Model SW-ATT-FOB2) is ready to use right out of the box.

Follow these steps to change the batteries:

1. Remove the top cover by inserting a coin in the slot located at the bottom of the keychain remote and turn it ninety (90) degrees.



2. Use a small Phillips Head screwdriver to remove the screw located in the center of the printed circuit board. (Do not discard the screw.)

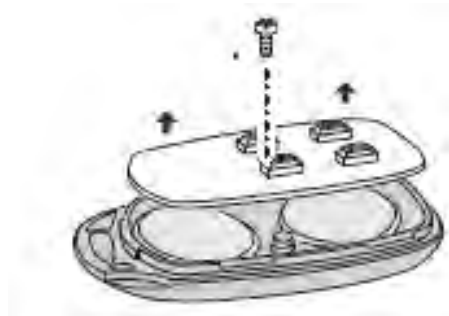

3. Remove the printed circuit board.
4. Remove the two depleted batteries and dispose of them as required by local laws.

5. Insert the two (2) replacement CR2025 Lithium (Panasonic[®] CR-2025L/BN) batteries, paying careful attention to the batteries polarity.

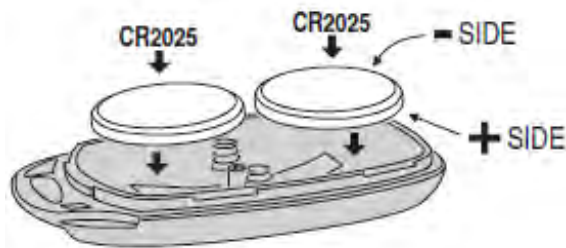

NOTE: The positive (+) side of the batteries should be facing down.

6. Replace the printed circuit board with the side with the two large circles facing the batteries.
7. Secure the printed circuit board by screwing it in place with the screw previously removed using a small Phillips Head screwdriver.
8. Snap the cover of the keychain remote transmitter over the base assembly.
9. Verify that the keychain remote is working properly by pushing the buttons. You will see the red LED illuminate if the transmitter is working.

6.2.2.2 Discovering and Registering the Keychain Remote (Model SW-ATT-FOB2)

Follow these steps to discover and register the Keychain Remote (Model SW-ATT-FOB2):

Step	Action
1.	Place the DLC-200C into Discovery Mode in DLD.
2.	Make the Keychain Remote (Model SW-ATT-FOB2) discoverable by pressing and holding all four (4) buttons simultaneously. NOTE: The LED will slowly blink GREEN during discovery, then illuminates solid GREEN once discovered.
3.	Confirm that the keychain remote has been discovered in DLD.
4.	Label the keychain remote in DLD.

AT&T Proprietary Information. All rights reserved.

6.2.2.3 Specifications—Keychain Remote (Model SW-ATT-FOB2)

Specifications—Keychain Remote (Model SW-ATT-FOB2)	
AT&T Model Number	SW-ATT-FOB2
Voltage	3V
Required Batteries	2
Specifications—Keychain Remote (Model SW-ATT-FOB2)	
Battery Type	CR2025 Lithium (Panasonic [®] CR-2025L/BN)
Projected Battery Life	2 years NOTE: The projected battery life was not verified by UL.
Operating Frequency	915 MHz
Open Air Wireless Signal Range	Up to 500 feet NOTE: This distance was not verified by UL.
Operating Environment	Temperature: 14°F to 131°F (0°C to 49°C) Relative Humidity: 5% to 85%, non-condensing

6.3 *Smoke Sensor (Model 562NSTT-OEM-ATT01) (Supplementary use only. Not part of the UL Listed Fire and Security System.)*

The AT&T model number 562NSTT-OEM-ATT01 is a proprietary two-way 915 MHz photoelectric smoke alarm with a built-in transmitter designed for use with the DLC-200C, as shown in Figure 49. When smoke is detected, the Smoke Sensor sounds a loud local temporal 3 alarm (three short beeps then silence repeating). Twenty (20) seconds after the local alarm sounds, the built-in transmitter sends a digitally coded wireless Smoke Sensor signal to the DLC-200C. The wireless signal will be repeated every twenty (20) seconds as long as smoke is still present. When the Smoke Sensor is sounding an alarm, the 915 MHz indoor siren (SW-ATT-SRN) will also be sounding a temporal 3 alarm.

In addition to the photoelectric sensor, the unit contains an integrated fixed 135° temperature and rate-of-rise heat sensor that will send an alarm signal to the DLC-200C based on temperature detected. It also contains built-in drift compensation that allows the product to adjust sensitivity automatically as it becomes dirty over time. The drift compensation feature dramatically increases the time between cleanings, as well as reducing the chance of a nuisance alarm.

Figure 49: Smoke Sensor (562NSTT-OEM-ATT01)

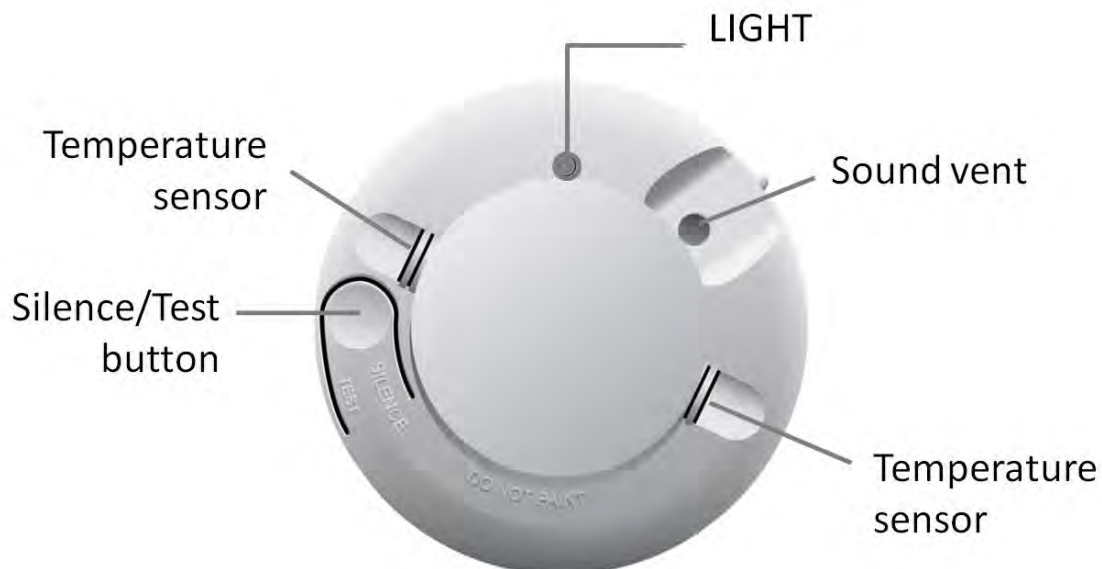

6.3.1.1 Smoke Sensor (Model 562NSTT-OEM-ATT01) LED Functions

The operation of the Smoke Sensor (Model 562NSTT-OEM-ATT01) LED is outlined below:

- Flashing—Flashes every eight (8) seconds to indicate normal operation.
- On—Detects smoke.
- Off—Trouble or maintenance is required.

6.3.1.2 Selecting Location(s) for Installation for the Smoke Sensor (Model 562NSTT-OEM-ATT01)

Smoke Sensors should be installed in accordance with Chapter 2 of the National Fire Alarm Code, ANSI/NFPA 72.

6.3.1.2.1 *Existing Construction*

For existing construction Smoke Sensors are best located between the bedroom areas and the rest of the home. In homes with only one bedroom area on one floor, the Smoke Sensor(s) should be located between the sleeping area and the rest of the family living unit as shown in Figure 50 - A. Multiple Smoke Sensors are required for homes with more than one sleeping area, as shown in Figure 50 - B. For split-level homes with multi-living areas, Smoke Sensors are required for each living area, including adjacent lower levels, the hallway to adjoining sleeping areas and basement area (if applicable), as shown in Figure 50- C. For multiple-level homes, including the basement, Smoke Sensors are required in the hallway of each level and near the basement stairwell, as shown in Figure 50 - D.

In addition, it is recommended that Smoke Sensors be located in areas separated by a door from protected areas to provide increased protection.

Figure 50: Smoke Sensor Location for Existing Construction

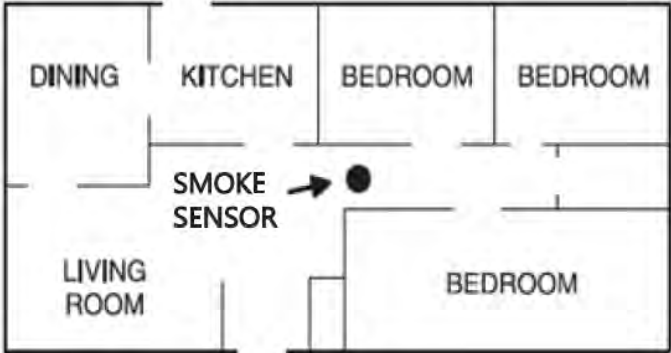
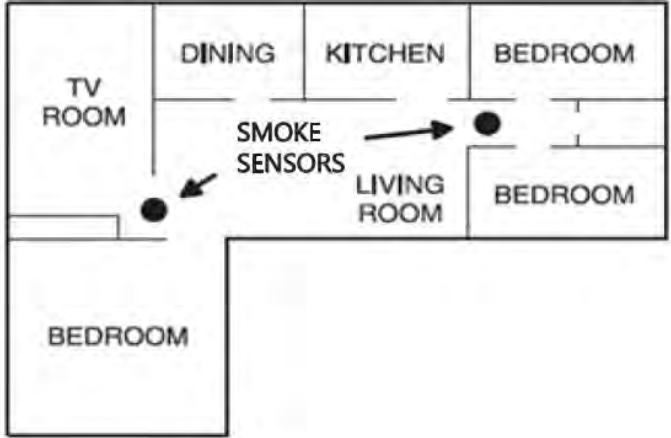
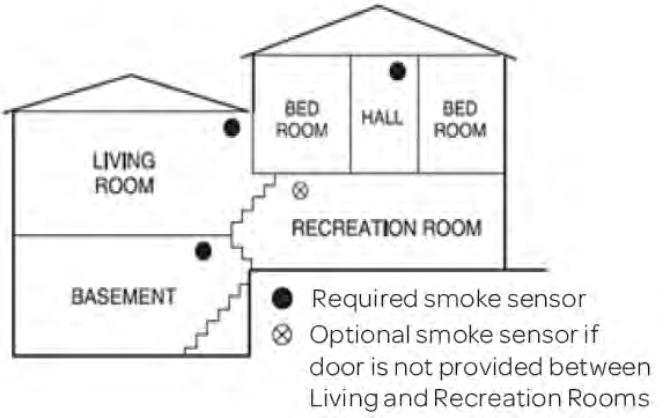
Description	Installation Location
A – Family Unit with One Level and all bedrooms are located in the same proximity	
B – Family Unit with One Level and bedrooms are located in different proximities	
C – Family Unit with One or More Split Levels	 <p> Required smoke sensor X Optional smoke sensor if door is not provided between Living and Recreation Rooms </p>

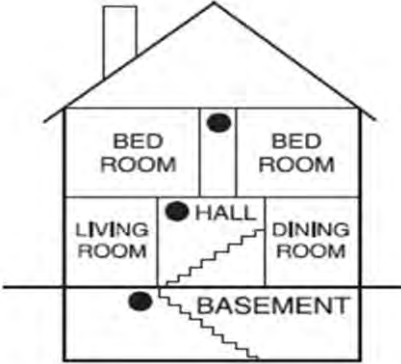
Description	Installation Location
D – Family Unit with Multiple Levels	

6.3.1.2.2 New Construction

For new construction, Smoke Sensors should be installed in the same areas as noted in Existing Construction, as well as in each bedroom.

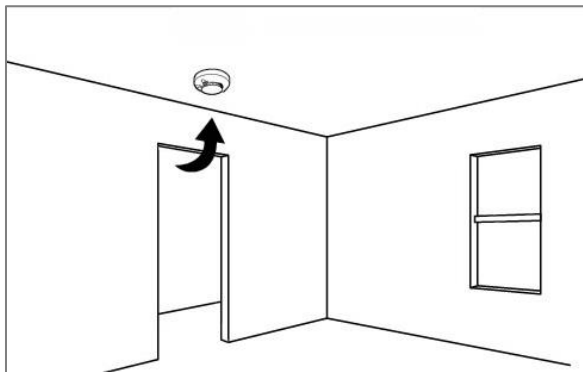

6.3.1.3 Installing/Replacing the Smoke Sensor (Model 562NSTT-OEM-ATT01) Batteries

The Smoke Sensor (562NSTT-OEM-ATT01) is shipped with two (2) batteries installed. When the batteries are low, the integral transmitter will send a low battery report to the DLC-200C, the Smoke Sensor LED is extinguished and the Smoke Sensor will chirp every forty-five (45) seconds until the batteries are replaced. The low battery trouble chirps can be silenced for twenty-four (24) hours by pressing the TEST/SILENCE button. Typical battery life is a minimum of one year, but varies depending on how often the unit is tested.

Use only 3V lithium batteries, as listed on the battery compartment cover. Follow these steps to install/replace the batteries:

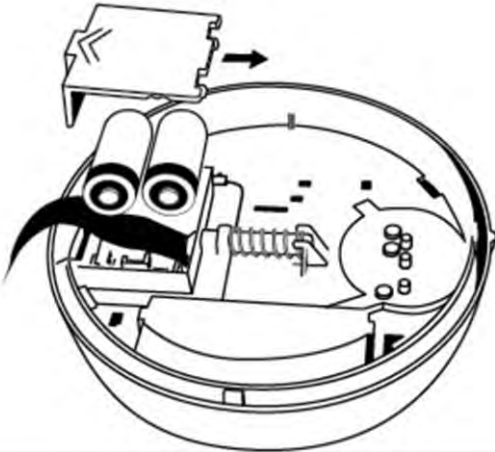
Step	Action
1.	Remove the unit from the mounting base. Grasp the unit and turn it counter clockwise approximately 15 degrees.
2.	Slide the battery compartment cover away from the smoke alarm to unsnap it and lift it off. 
3.	Remove the batteries, if applicable, and dispose of them properly.
4.	Insert two (2) new 3V Panasonic® CR123A lithium batteries into the battery compartment and replace the cover. Make sure to check the polarity, NOTE: Pull and hold the spring guard and insert the battery closest to the spring guard first. This will make it easier to install the remaining battery.
5.	Reattach the unit to the mounting base.
6.	Test the system.

WARNING!

This Smoke Sensor will not operate and the alarm will not sound if the batteries are dead or not installed properly.

6.3.1.4 Discovering and Registering the Smoke Sensor (Model 562NSTT-OEM-ATT01)

Follow these steps to discover and register the Smoke Sensor (Model 562NSTT-OEM-ATT01) using the Discovery button:

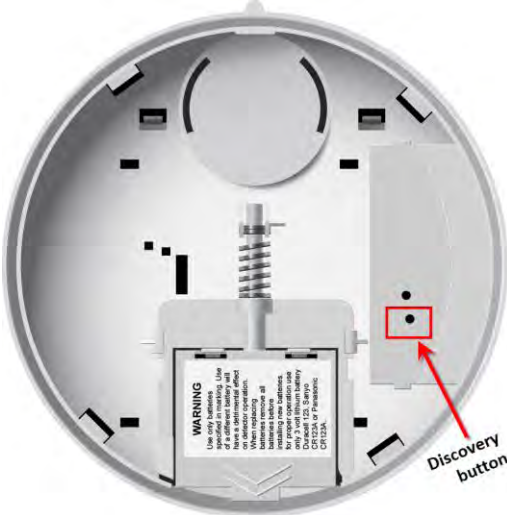
Step	Action
1.	Place the DLC-200C into Discovery Mode in DLD.
2.	<p>Remove the rear panel cover and insert the tip of a pen or paperclip into the Discovery button hole, then press and hold the Smoke Sensor (Model 562NSTT-OEM-ATT01) Learn/Discovery button for two (2) seconds.</p>  <p>NOTE: The Learn LED is located above to the Discovery button.</p> <p>One or more of the following functions should occur:</p> <ul style="list-style-type: none"> • The Learn LED will slowly blink RED while the smoke sensor is being discovered by the system. This process may take as long as 60 seconds. • If the smoke sensor is successfully discovered, the learn LED will turn solid RED for 15 seconds • If the smoke sensor is not discovered, the Learn LED will blink fast for 15 seconds

AT&T Proprietary Information. All rights reserved.

Step	Action
3.	Confirm that the Smoke Sensor has been discovered in DLD.
4.	Label the Smoke Sensor in DLD.

6.3.1.5 Installing/Mounting the Smoke Sensor (Model 562NSTT-OEM-ATT01)

Follow these steps to install/mount the Smoke Sensor (Model 562NSTT-OEM-ATT01):

Step	Action
1.	Remove the red plastic dust cover from the unit and return to the marked location(s).
2.	Using the two (2) screws and anchors provided, mount the base.
3.	<p>Attach the unit to the base as follows:</p> <ul style="list-style-type: none"> • Line up the raised alignment tab on the lip of the unit with the alignment arrow on the base. • Insert the unit into the base and turn clockwise approximately fifteen (15) degrees. It should snap firmly into place. <div data-bbox="634 1260 1136 1711" data-label="Image"> </div> <p>IMPORTANT! The unit cannot be attached to the base if no batteries are installed.</p>

6.3.1.6 Testing the Smoke Sensor (Model 562NSTT-OEM-ATT01)

To test the sensitivity of the Smoke Sensor (Model 562NSTT-OEM-ATT01), do the following:

1. Press and hold the TEST/SILENCE button for four (4) seconds. Once the test starts, the smoke sensor LED flashes 1 to 9 times.
2. Count the number of LED flashes and use the following table to determine if any action is necessary.

LED Flashes Indication—Action	
1	Unserviceable hardware fault. Reset smoke sensor and rerun sensitivity test. If error persists, replace the unit.
2-3	Smoke Sensor is becoming insensitive. Clean the unit, reset it and rerun the sensitivity test. If error persists, replace the unit.
4-7	Unit is within normal sensitivity range. No action required.
8-9	Smoke Sensor is becoming too insensitive. Verify smoke chamber is snapped down securely. Clean the smoke alarm and replace the smoke chamber.

6.3.1.7 Cleaning the Smoke Sensor (Model 562NSTT-OEM-ATT01)

Clean the smoke sensor cover with a dry or damp (water) cloth as needed to keep it free from dust and dirt. When necessary, use the following procedure to clean the interior of the smoke alarm and replace the smoke chamber.

1. Remove the Smoke Sensor (Model 562NSTT-OEM-ATT01) from the mounting base.
2. Remove the batteries.
3. Slide a flat-blade screwdriver in the sensor cap slot and gently push the handle down to pry the cap up and off the base of the smoke sensor.

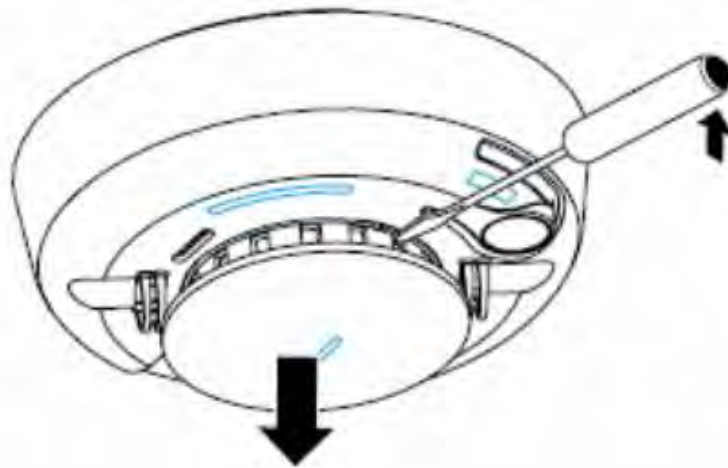

4. Squeeze the smoke chamber where indicated by the alignment arrows, then pull it up and away from the smoke sensor and discard.

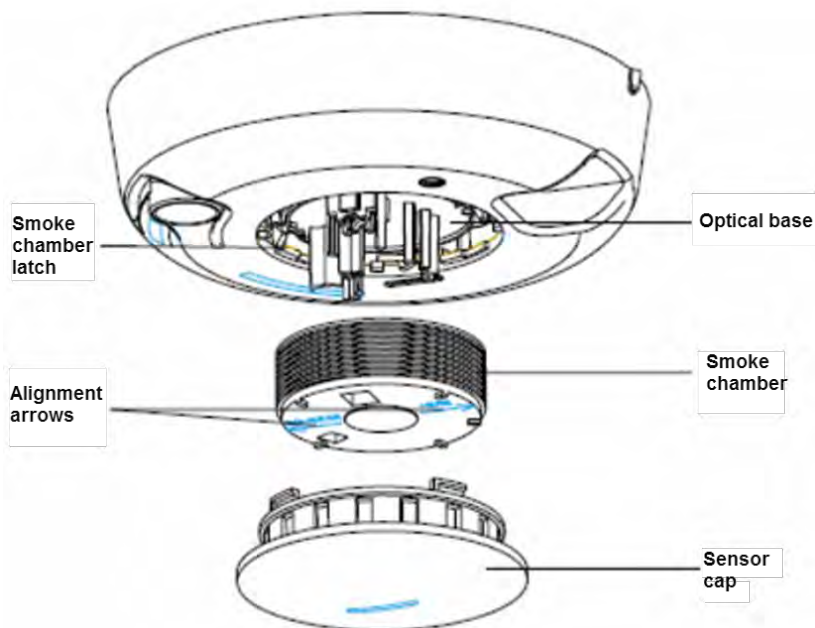

5. Gently blow on the smoke chamber, or use a soft-bristled brush, to remove dust and dirt from the smoke chamber base.
6. Line up the clean or new smoke chamber with the optical base. Align the arrows on the smoke chamber to the latches on the optical base, then gently press down and snap into place.

7. Replace the Sensor cap.
Align the sensor cap with the smoke sensor base then insert the sensor cap into the smoke sensor base and turn clockwise approximately 15 degrees. The cap snaps firmly into place when secure.
8. Insert the batteries into the rear of the smoke sensor, observing the proper polarity, and replace the battery compartment cover.
9. Reattach the smoke sensor to its mounting base
10. Perform the Sensitivity Test. (See, 6.3.1.6 Testing the Smoke Sensor (Model 562NSTT-OEM-ATT01))
11. Verify all auxiliary functions for a complete test of the system.

6.3.1.8 Maintaining the Smoke Sensor (Model 562NSTT-OEM-ATT01)

The units are designed for easy field service and maintenance. When installed and used properly, they require minimal maintenance. Follow these guidelines:

- Test the unit weekly. (See, Section 6.3.1.6 Testing the
- Clean the cover with a dry or damp (water) cloth as needed to keep it free from dust and dirt. (See, 6.3.1.7 Cleaning the)
- When a unit requires maintenance, it extinguishes its LED and stops sending supervisory signals to the alarm DLC-200C. If the DLC-200C indicates supervisory trouble for the smoke alarm, perform the sensitivity test and follow the recommended actions.

6.3.1.9 Specifications—Smoke Sensor (Model 562NSTT-OEM-ATT01)

Specifications—Smoke Sensor (Model 562NSTT-OEM-ATT01)	
AT&T Model Number	562NSTT-OEM-ATT01
Voltage	3VDC Lithium
Current	<ul style="list-style-type: none"> • Typical average standby current 35μA • Typical test current 2mA

Specifications—Smoke Sensor (Model 562NSTT-OEM-ATT01)	
	<ul style="list-style-type: none"> • Typical alarm current 70mA
Required Batteries	2
Battery Type	3V Lithium (Panasonic® CR123A)
Projected Battery Life	5 years (typically)
Low Battery Threshold	2.70V causes low battery signal
Low Battery Beep Rate	1 every 45 seconds
Operating Frequency	915 MHz (NA) & 868 MHz (EMEA)
Sounder	85 dBa at 10' (3M) temporal 3 pattern
Sensitivity	2.2% ± 1.3% / ft.
Storage Temperature	4° to 140°F (-20° to 60°C)
Operating Environment	Temperature: 32° to 100°F (0°-38°C) Relative Humidity: 0 to 95% non-condensing
Dimensions	4.68" x 2.75" x 1.85" (119 x 70 x 47 mm)
Alarm Dimensions	5.6" x 2.4" (14.2 cm x 6.1cm)
Base Dimensions	5.4" x 0.46" (13.7 cm x 1.17cm)
Drift Compensation Adjustment	0.5% / ft. max.
Heat Detector Specifications	<ul style="list-style-type: none"> • Rate-of-rise 15°F/min>105°F • 8.3°C/min>40.6°C • Fixed 135°F ± 5°F (57.2°C ± 2.8°C)

6.3.2 Indoor Siren (Model SW-ATT-SRN) (915MHz)

The AT&T model number **SW-ATT-SRN** is a proprietary 915 MHz wireless indoor siren that is capable of annunciating alarms and keypad chirps. The indoor siren has one (1) annunciator and one (1) LED, which are located on the front panel, as shown in Figure 51.

Figure 51: Indoor Siren (Model SW-ATT-SRN) Front Panel



The DLC-200C sends messages to the indoor siren via a proprietary 915 MHz radio protocol to command the indoor siren to generate tones and pre-programmed alarm sequences through its annunciator, including a temporal 3 - alarm (three short beeps then silence repeating) when a smoke alarm is activated and a temporal 4 alarm (four short beeps then silence repeating) when the CO alarm is activated. In addition the indoor siren beeps during an intrusion alarm.

The LED shows the system status, as follows:

- Solid Green—unit is AC powered and backup battery is good.
- Blinking Green—unit is not AC powered and is operating on backup batteries.
- Solid Red—unit is AC powered and the backup battery needs to be replaced.
- Off—unit is not AC powered and backup battery has failed.



6.3.2.1 Installing/Replacing the Indoor Siren (Model SW-ATT-SRN) Batteries

The indoor siren has two (2) non-rechargeable 3V CR123 (Duracell® DL123A, Panasonic® CR123A) batteries that provide twenty-four (24) hour battery backup. The batteries can be replaced by opening the battery compartment located on the rear of the unit.



CAUTION: Replace batteries with Duracell® DL123A, Panasonic® CR123A only. Use of another battery may present a risk of fire or explosion.

6.3.2.2 Installing the Indoor Siren (Model SW-ATT-SRN)

Follow these steps to install the Indoor Siren:

Action	Illustration
1. Turn the Indoor Siren to its underside and remove the Phillips Head screw at the bottom to open battery compartment cover.	
2. Remove the battery compartment cover.	

AT&T Proprietary Information. All rights reserved.

Action	Illustration
<p>3. Insert two (2) non-rechargeable CR123 batteries.</p> <p>NOTE: Ensure that polarity of the batteries is correct during installation.</p>	 <p>T15716</p>
<p>4. Replace the battery compartment cover and the Phillips Head screw.</p>	 <p>T15717</p>
<p>5. Plug the unit into the lower socket of an AC outlet and install a retaining screw into the plastic tab located at the top of the unit to secure the unit to the AC outlet.</p>	 <p>T15717</p>

NOTE: Installation instructions are provided for reference only. Consult the Installation Instruction Manual (Part Number: 2347231) that is shipped with the device for further details.