



## **QUICK START GUIDE**



# **Cisco Universal Small Cell 7330**

Revised: November, 2013, 78-21441-03

## Table of Contents

- 1** About Your Small Cell
- 2** Before You Begin
- 3** Safety Instructions
- 4** Connect Your Small Cell
- 5** Mount Your Small Cell
  - Mounting on a Wall or Hard Ceiling
  - Mounting on a Suspended Ceiling
  - Mounting on a Suspended Ceiling Using an Existing Bracket
  - Mounting in a Plenum Space
- 6** Verify that Your Small Cell is Operating Correctly
- 7** Declarations of Conformity and Regulatory Information
- 8** Specifications
- 9** Obtaining Documentation and Submitting a Service Request

# 1 About Your Small Cell

The Cisco Universal Small Cell (USC) 7330 is an indoor small cell that provides Wideband Code Division Multiple Access (WCDMA) coverage and capacity to public areas where macro networks are not cost-effective. The USC 7330 supports up to 16 active third-generation (3G) users and supports Band 2/5 for the American market and Band 1 for the rest of the world.

## Package Contents

Your Cisco USC 7330 small cell is shipped with the following:

- Power supply unit—European Union (EU) compatible type plug for Band 1 and US compatible plug for Band 2/5. Other plug types must be ordered separately.
- Suspended ceiling mount bracket—to mount the small cell on a ceiling.
- Rail mounting accessory pack, including screws.
- Ethernet cable.
- This Quick Start Guide.

**Figure 1 Cisco USC 7330 Top View**

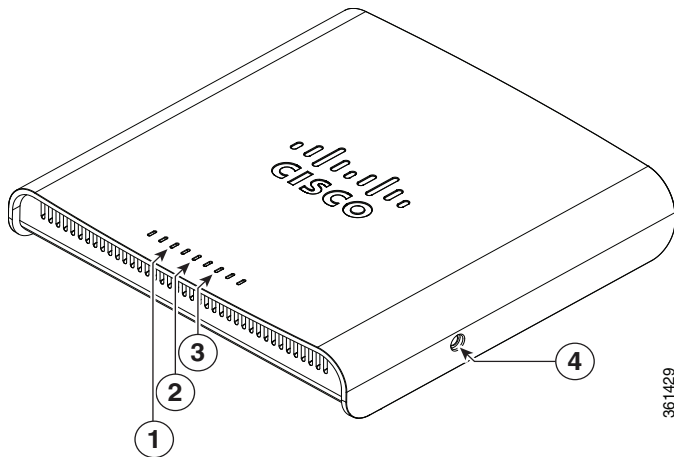

<b>1</b>	Power LED
<b>2</b>	Ethernet connection LED
<b>3</b>	Status LED
<b>4</b>	External antenna port

## 2 Before You Begin

Consider where you want to install your new small cell. The ideal location is:

- somewhere central, away from windows—this will allow your small cell to provide the best possible coverage.
- at least one 30 cm (1 foot) from other wireless broadcasting devices to avoid possible interference.
- where you can connect to your broadband router or cable modem.

Decide whether you will mount your small cell on a wall or ceiling, or whether you will place it on a desktop or other flat surface.

## 3 Safety Instructions

Translated versions of the following safety warnings are provided in *Cisco USC 7330 Regulatory Compliance and Safety Information*, located on Cisco.com.



**Warning**

---

### IMPORTANT SAFETY INSTRUCTIONS

**This warning symbol means danger. You are in a situation that could cause bodily injury. Before you work on any equipment, be aware of the hazards involved with electrical circuitry and be familiar with standard practices for preventing accidents. Use the statement number provided at the end of each warning to locate its translation in the translated safety warnings that accompanied this device.** Statement 1071

---

### SAVE THESE INSTRUCTIONS



**Warning**

---

**Read the installation instructions before you connect the system to its power source.** Statement 1004

---



---

**Warning**

**Installation of the equipment must comply with local and national electrical codes.** Statement 1074

---



---

**Warning**

**This product relies on the building's installation for short-circuit (overcurrent) protection. Ensure that the protective device is rated not greater than: 20A.** Statement 1005

---



---

**Warning**

**Do not operate the unit near unshielded blasting caps or in an explosive environment unless the device has been modified to be especially qualified for such use.** Statement 364

---



---

**Warning**

**In order to comply with FCC radio frequency (RF) exposure limits, antennas should be located at a minimum of 7.9 inches (20 cm) or more from the body of all persons.** Statement 332

---



---

**Caution**

The fasteners you use to mount an access point on a ceiling must be capable of maintaining a minimum pullout force of 20 lbs (9 kg) and must use all indented holes on the mounting bracket.

---



---

**Caution**

This product and all interconnected equipment must be installed indoors within the same building, including the associated LAN connections as defined by Environment A of the IEEE 802.af Standard.

---



---

**Note**

Your small cell is suitable for use in environmental air space in accordance with section 300.22.C of the National Electrical Code and sections 2-128, 12-010(3), and 12-100 of the Canadian Electrical Code, Part 1, C22.1. You should not install the power supply or power injector in air handling spaces.

---



---

**Note**

Use only with listed ITE equipment.

---



## 4 Connect Your Small Cell

Figure 2 Cisco USC 7330 Connections

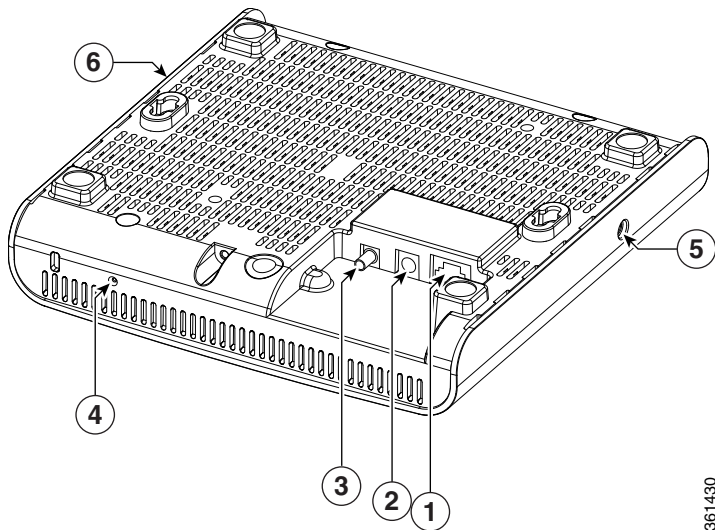

1	10/100 Base-T Ethernet port supporting PoE+
2	Power port
3	GPS port (available on Band 2/5 only)

361430

<b>4</b>	Reset button
<b>5</b>	2G external antenna port for the Band 1 small cell (USC7330-T1-K9) or UMTS Band V external antenna port for the Band 2/5 small cell (USC7330-T2-K9)
<b>6</b>	3G external antenna port for the Band 1 small cell (USC7330-T1-K9) or UMTS Band II external antenna port for the Band 2/5 small cell (USC7330-T2-K9)

- 
- Step 1** Connect one end of the network cable to the small cell Ethernet port and the other end to your broadband router or cable modem.
- Step 2** Connect the power adaptor to the power port and then switch on at the mains.
- Step 3** (Optional) If you have a Band 2/5 small cell, you can connect a GPS antenna to the GPS port.
- Step 4** (Optional) You can connect an external antenna. For the USC7330-T1-K9, connect an external antenna for the Sniff bands (Bands 3 and 8) to connector 5 and connect the external antenna for Band 1 to connector 6 (Figure 2). For the USC7330-T2-K9, connect an external antenna for Band 5 to connector 5 and connect the external antenna for Band 2 to connector 6 (Figure 2).

**Step 5** Wait ten minutes for your small cell to be ready to use. The status LED stops flashing green and becomes solid green when your small cell is ready to use.

---

## 5 Mount Your Small Cell

### Mounting on a Wall or Hard Ceiling

If you need to mount your small cell on a wall or hard ceiling, hang it on two screws projecting from the surface. Attach the screws to the wall or ceiling such that the distance between the screws matches the distance between the mounting holes on the back of your small cell.

**Figure 3** Cisco USC 7330 Mounted Vertically on Wall

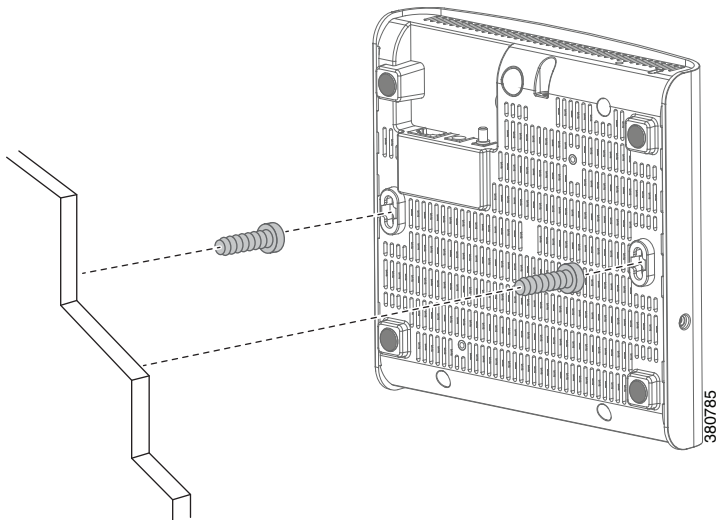

## Mounting on a Suspended Ceiling

If you need to mount your small cell on a suspended ceiling, follow these steps:

---

- Step 1** Place your small cell on a clean, flat surface with the bottom side facing you.
- Step 2** Take two screws from the accessory kit and screw them into each of the two corresponding holes on the bottom of the small cell.
- Step 3** Attach the suspended ceiling bracket to the ceiling rail system using the two “L” brackets included in the accessory pack and eight screws.
- Step 4** Place the small cell such that the attached mounting screws fit into the suspended ceiling bracket keyhole mounting slots.
- Step 5** Slide the small cell onto the mounting bracket until it clicks into place.

**Figure 4** Cisco USC 7330 with Suspended Ceiling Bracket

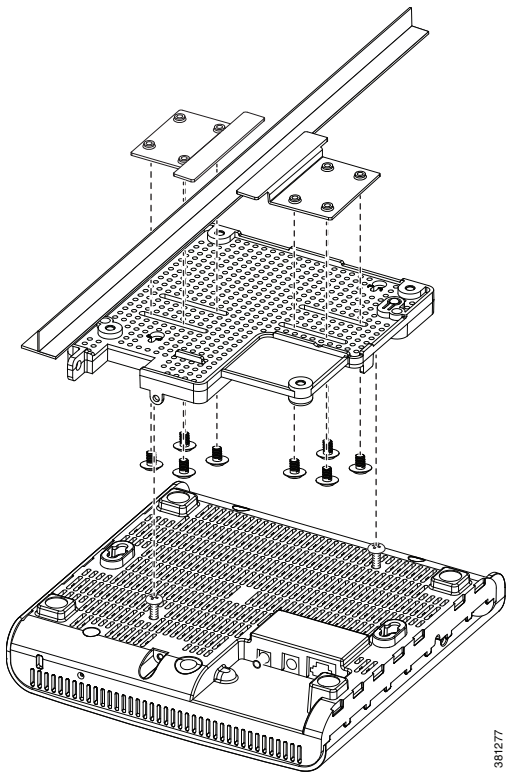

361277

**Step 6** Screw the provided security locking screw into place to lock the bracket into position.

**Figure 5** *Suspended Ceiling Bracket with Locking Screw*

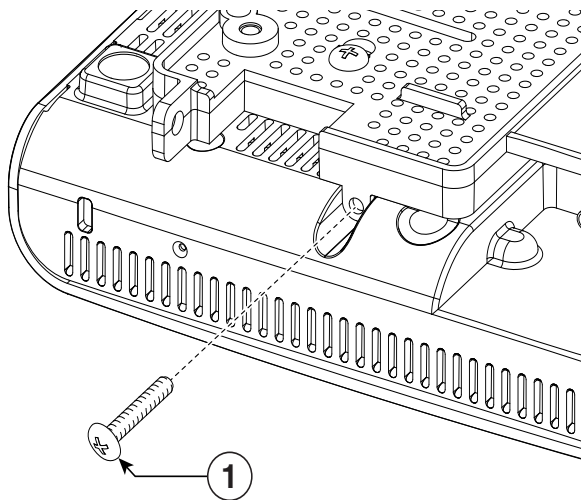

361433

---

<b>1</b>	Security locking screw
----------	------------------------

---

## Mounting on a Suspended Ceiling Using an Existing Bracket

If you have an existing Low-Profile AP bracket (AIR-AP-BRACKET-1) attached to a suspended ceiling that you want to use for your Cisco USC 7330, perform this task:

- 
- Step 1** Connect the suspended ceiling bracket to your small cell as described in [Mounting on a Suspended Ceiling, page 13](#): perform [Step 1](#), [Step 2](#) and [Step 4](#) to [Step 6](#).
  - Step 2** Screw the four metal feet into the four corresponding holes on the bottom of the suspended ceiling bracket. The rubber feet attachments are not required.



**Figure 6**      **Suspended Ceiling Bracket with Attached Feet**

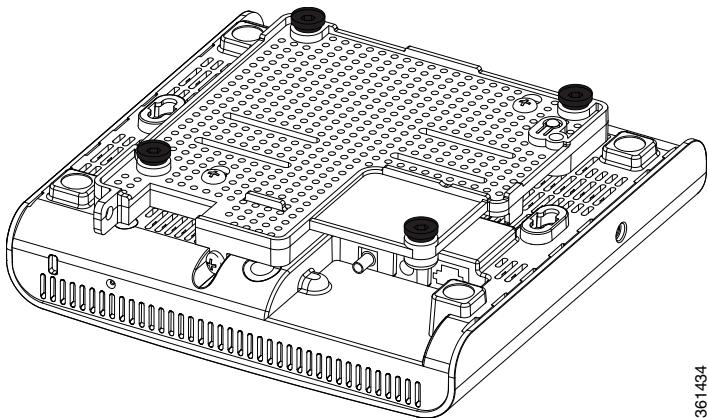

361434

- Step 3**      Attach the USC 7330 small cell to the Low-Profile AP bracket (AIR-AP-BRACKET-1) as described in *Access Point Mounting Instructions*:  
[http://www.cisco.com/en/US/partner/docs/wireless/access\\_point/mounting/guide/apmount.html](http://www.cisco.com/en/US/partner/docs/wireless/access_point/mounting/guide/apmount.html)
- Step 4**      Fasten a padlock to secure the small cell to the brackets and prevent theft. See “[Securing the Access Point to the Mounting Plate](#)” for more information.

**Figure 7** Cisco USC 7330 with Padlock Attached

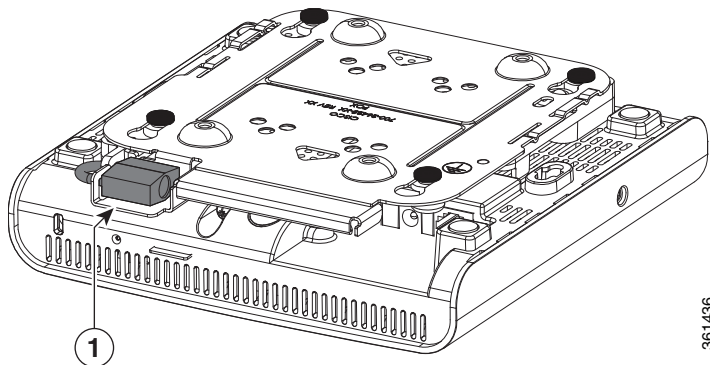

361436

---

<b>1</b>	Padlock
----------	---------

---

## Mounting in a Plenum Space

To mount your small cell in a plenum space, you have two options:

1. Connect the suspended ceiling bracket to a secure location in the plenum space and then connect your small cell to the suspended ceiling bracket as described in [Mounting on a Suspended Ceiling, page 13](#): perform [Step 1](#), [Step 2](#) and [Step 4](#) to [Step 6](#).
2. Connect your small cell to the suspended ceiling bracket as described in [Mounting on a Suspended Ceiling Using an Existing Bracket](#). Then connect this to another bracket as described in *Access Point Mounting Instructions*: [http://www.cisco.com/en/US/partner/docs/wireless/access\\_point/mounting/guide/apmount.html](http://www.cisco.com/en/US/partner/docs/wireless/access_point/mounting/guide/apmount.html).

## 6 Verify that Your Small Cell is Operating Correctly

The LED display is located on the front of your small cell. Note the color and activity of the LEDs and refer to this table to diagnose any problems that you may be experiencing.

**Table 1**      **USC 7330 Status LED Indications**

<b>LED Indication</b>	<b>Small Cell State/Action</b>
Off	No power—ensure power supply is connected and turned on
Fast Green	Initialization or provisioning—wait for this action to complete
Green	In service with no calls or data sessions—ready to support calls
Slow Green	In service with active calls or data sessions
Red Flash 1 times in 4 seconds	No connection to local broadband router—verify the connection between the broadband router and your small cell and verify that the broadband router is operational
Red Flash 2 times in 4 seconds	No Internet connection—verify that the broadband router is connected to the Internet and is providing service
Red Flash 3 times in 4 seconds	Interference with other systems—try placing your small cell in a different place. If this problem persists, contact customer support
Red Flash 4 times in 4 seconds	Overheating—verify that the small cell is located where there is proper air flow

**Table 1**      **USC 7330 Status LED Indications (continued)**

<b>LED Indication</b>	<b>Small Cell State/Action</b>
Red	Initial boot—wait up to 20 minutes; if the state does not change, perform a reset
	Cannot create secure connection—contact customer support
	Internal fault—small cell has a fault and cannot provide service
	RF issue, cannot select an RF profile—verify whether another small cell is located in close proximity and if so, relocate the unit
	Provisioning failure—contact customer support

## **7**    **Declarations of Conformity and Regulatory Information**

This section provides declarations of conformity and regulatory information for the Cisco USC 7330. For more information, refer to *Cisco USC 7330 Regulatory Compliance and Safety Information* on Cisco.com.

The USC7330-T1-K9 carries the CE Mark:



## **Class B Notice for FCC**

Modifying the equipment without Cisco's authorization may result in the equipment no longer complying with FCC requirements for Class B digital devices. In that event, your right to use the equipment may be limited by FCC regulations, and you may be required to correct any interference to radio or television communications at your own expense.

This equipment has been tested and found to comply with the limits for a Class B digital device, pursuant to Part 15 of the FCC Rules. These limits are designed to provide reasonable protection against harmful interference in a residential installation. This equipment generates, uses and can radiate radio frequency energy and, if not installed and used in accordance with the instructions, may cause harmful interference to radio communications. However, there is no guarantee that interference will not occur in a particular installation. If this equipment does cause harmful interference to radio or television reception, which can be determined by

turning the equipment off and on, the user is encouraged to try to correct the interference by one or more of the following measures:

- Reorient or relocate the receiving antenna.
- Increase the separation between the equipment and receiver.
- Connect the equipment into an outlet on a circuit different from that to which the receiver is connected.
- Consult the dealer or an experienced radio/TV technician for help.

## Declaration of Conformity Statements

All the Declaration of Conformity statements related to this product can be found at the following URL:

<http://www.ciscofax.com>

## 8 Specifications

- Product numbers:  
USC7330-T1-K9—Band 1  
USC7330-T2-K9—Band 2/5
- 3GPP UMTS Rel-8 compliance
- GSM and UMTS Macrocell sniffers

- Support for 16 CS and PS simultaneous users
- Support for HSDPA: 14.4 Mbps downlink, 5.7 Mbps uplink UMTS operating and network listen band options
  - Band I (2100) [EU]
  - Band II (1900) and Band V (850) [US]
- GSM network listen band options
  - Band III (1800) and Band VIII (900) [EU]
  - Band II (1900) and Band V (850) [US]
- Maximum transmit power UMTS
  - 24 dBm (energy consumption < 12 Watt)
- Sensitivity: -113 dBm
- UL sensitivity compliant to 3GPP TS25.104
- Embedded 3G and GSM omnidirectional antennas
- USC7330-T2-K9: GPS with external GPS antenna connector
- Dimensions (L x W x D): 7.20 x 7.17 x 1.50 inches (18.3 x 18.2 x 3.8 cm)
- Weight:
  - USC7330-T1-K9: 1.19 lbs (540 g);
  - USC7330-T2-K9: 1.21 lbs (550 g)
- Operating temperature: 32 to 104 degrees F (0 to 40 degrees C)



- Storage temperature: 23 to 113 degrees F (-5 to 45 degrees C)
- Humidity: 5% to 90% (noncondensing)
- Desktop/wall/ceiling mountable
- Green initiative compliant to RoHS

## External Antenna Requirements

Before attaching an external antenna to your small cell, note the following requirements:

**Table 2**      **UMTS Antenna Requirements**

Gain	0 dBi mean; < 2 dBi peak
Ripple	+/- 2 dB
Azimuth Beamwidth	Omni
Elevation Beamwidth	Omni
Isolation: UMTS to GSM listen UMTS to WLAN	> 15 dB > 15 dB
Feed System	Coaxial feed
Return loss	< -10 dB over band specified
Power rating	> +24 dBm

**Table 2 UMTS Antenna Requirements (continued)**

Polarization	Linear
Connector type	MMCX 50 Ohm

**Table 3 GSM Antenna Requirements**

Gain	0 dBi mean az plane; < 2 dBi peak
Ripple	+/- 2 dB
Azimuth Beamwidth	Omni
Elevation Beamwidth	Omni or similar to vertical mounted dipole; nulls at $\theta=0$ and 180 degrees are acceptable
Isolation: GSM to UMTS listen GSM to WLAN	> 15 dB > 15 dB
Feed System	Coaxial feed
Return loss	< -6 dB over band specified
Power rating	> 0 dBm
Polarization	Linear
Connector type	MMCX 50 Ohm

## GPS Antenna Requirements

The GPS antenna port supports an active antenna with a 50-Ohm SMB connector.

# 9 Obtaining Documentation and Submitting a Service Request

For information on obtaining documentation, submitting a service request, and gathering additional information, see the monthly *What's New in Cisco Product Documentation*, which also lists all new and revised Cisco technical documentation:

<http://www.cisco.com/en/US/docs/general/whatsnew/whatsnew.html>

Subscribe to the *What's New in Cisco Product Documentation* as an RSS feed and set content to be delivered directly to your desktop using a reader application. The RSS feeds are a free service. Cisco currently supports RSS Version 2.0.



---

**Americas Headquarters**  
Cisco Systems, Inc.  
San Jose, CA

**Asia Pacific Headquarters**  
Cisco Systems (USA) Pte. Ltd.  
Singapore

**Europe Headquarters**  
Cisco Systems International BV Amsterdam,  
The Netherlands

Cisco has more than 200 offices worldwide. Addresses, phone numbers, and fax numbers are listed on the Cisco Website at [www.cisco.com/go/offices](http://www.cisco.com/go/offices).

---

Printed in China PRC



78-21441-03A0

## Europe – EU Declaration of Conformity

This device complies with the essential requirements of the R&TTE Directive 1999/5/EC. The following test methods have been applied in order to prove presumption of conformity with the essential requirements of the R&TTE Directive 1999/5/EC:

- EN50385 : 2002 / Article 3(1)(a)  
Product standard to demonstrate the compliance of radio base stations and fixed terminal stations for wireless telecommunication systems with the basic restrictions or the reference levels related to human exposure to radio frequency electromagnetic fields (110MHz - 40 GHz) - General public
- EN 301 908-1 V5.2.1: 2011  
Electromagnetic compatibility and Radio spectrum Matters (ERM); Base Stations (BS), Repeaters and User Equipment (UE) for IMT-2000 Third-Generation cellular networks; Part 1: Harmonized EN for IMT-2000, introduction and common requirements, covering essential requirements of article 3.2 of the R&TTE Directive
- EN 301 511 V9.0.2: 2003  
Global System for Mobile communications (GSM); Harmonized standard for mobile stations in the GSM 900 and DCS 1800 bands covering essential requirements under article 3.2 of the R&TTE directive (1999/5/EC)
- EN 301 489-1 V1.9.2: 2008  
Electromagnetic compatibility and Radio Spectrum Matters (ERM); ElectroMagnetic Compatibility (EMC) standard for radio equipment and services; Part 1: Common technical requirements
- EN 301 489-7 V1.3.1: 2005  
ElectroMagnetic compatibility and Radio spectrum Matters (ERM); ElectroMagnetic Compatibility (EMC) standard for radio equipment ad services; Part 7: Specific conditions for mobile and portable radio and ancillary equipment of digital cellular radio telecommunications systems (GSM and DCS)

**<insert CE mark + notified body number + alert mark here>**

[cs]Česky [Czech]	[ <i>Jméno výrobce</i> ] tímto prohlašuje, že tento [ <i>typ zařízení</i> ] je ve shodě se základními požadavky a dalšími příslušnými ustanoveními směrnice 1999/5/ES.
[da]Dansk [Danish]	Undertegnede [ <i>fabrikantens navn</i> ] erklærer herved, at følgende udstyr [ <i>udstyrets typebetegnelse</i> ] overholder de væsentlige krav og øvrige relevante krav i direktiv 1999/5/EF.
[de]Deutsch [German]	Hiermit erkläre [ <i>Name des Herstellers</i> ], dass sich das Gerät [ <i>Gerätetyp</i> ] in Übereinstimmung mit den grundlegenden Anforderungen und den übrigen einschlägigen Bestimmungen der Richtlinie 1999/5/EG befindet.
[et]Eesti [Estonian]	Käesolevaga kinnitab [ <i>tootja nimi = name of manufacturer</i> ] seadme [ <i>seadme tüüp = type of equipment</i> ] vastavust direktiivi 1999/5/EÜ põhinõuetele ja nimetatud direktiivist tulenevatele teistele asjakohastele sätetele.
[en]English	Hereby, [ <i>name of manufacturer</i> ], declares that this [ <i>type of equipment</i> ] is in compliance with the essential requirements and other relevant provisions of Directive 1999/5/EC.
[es]Español [Spanish]	Por medio de la presente [ <i>nombre del fabricante</i> ] declara que el [ <i>clase de equipo</i> ] cumple con los requisitos esenciales y cualesquiera otras disposiciones aplicables o exigibles de la Directiva 1999/5/CE.
[el]Ελληνική [Greek]	ΜΕ ΤΗΝ ΠΑΡΟΥΣΑ [ <i>name of manufacturer</i> ] ΔΗΛΩΝΕΙ ΟΤΙ [ <i>type of equipment</i> ] ΣΥΜΜΟΡΦΩΝΕΤΑΙ ΠΡΟΣ ΤΙΣ ΟΥΣΙΩΔΕΙΣ ΑΠΑΙΤΗΣΕΙΣ ΚΑΙ ΤΙΣ ΛΟΙΠΕΣ ΣΧΕΤΙΚΕΣ ΔΙΑΤΑΞΕΙΣ ΤΗΣ ΟΔΗΓΙΑΣ 1999/5/ΕΚ.
[fr]Français [French]	Par la présente [ <i>nom du fabricant</i> ] déclare que l'appareil [ <i>type d'appareil</i> ] est conforme aux exigences essentielles et aux autres dispositions pertinentes de la directive 1999/5/CE.
[it]Italiano [Italian]	Con la presente [ <i>nome del costruttore</i> ] dichiara che questo [ <i>tipo di apparecchio</i> ] è conforme ai requisiti essenziali ed alle altre disposizioni pertinenti stabilite dalla direttiva 1999/5/CE.
Latviski [Latvian]	Ar šo [ <i>name of manufacturer / izgatavotāja nosaukums</i> ] deklarē, ka [ <i>type of equipment / iekārtas tips</i> ] atbilst Direktīvas 1999/5/EK būtiskajām prasībām un citiem ar to saistītajiem noteikumiem.
Lietuvių [Lithuanian]	Šiuo [ <i>manufacturer name</i> ] deklaruoją, kad šis [ <i>equipment type</i> ] atitinka esminius reikalavimus ir kitas 1999/5/EB Direktyvos nuostatas.
[nl]Nederlands [Dutch]	Hierbij verklaart [ <i>naam van de fabrikant</i> ] dat het toestel [ <i>type van toestel</i> ] in overeenstemming is met de essentiële eisen en de andere relevante bepalingen van richtlijn 1999/5/EG.
[mt]Malti [Maltese]	Hawnhekk, [ <i>isem tal-manifattur</i> ], jiddikjara li dan [ <i>il-mudel tal-prodott</i> ] jikkonforma mal-ħtiġijiet essenzjali u ma provvedimenti oħrajn rilevanti li hemm fid-Dirrettiva 1999/5/EC.
[hu]Magyar [Hungarian]	Alulírott, [ <i>gyártó neve</i> ] nyilatkozom, hogy a [ <i>... típus</i> ] megfelel a vonatkozó alapvető követelményeknek és az 1999/5/EC irányelv egyéb előírásainak.
[pl]Polski [Polish]	Niniejszym [ <i>nazwa producenta</i> ] oświadczam, że [ <i>nazwa wyrobu</i> ] jest zgodny z zasadniczymi wymogami oraz pozostałymi stosownymi postanowieniami Dyrektywy 1999/5/EC.
[pt]Português [Portuguese]	[ <i>Nome do fabricante</i> ] declara que este [ <i>tipo de equipamento</i> ] está conforme com os requisitos essenciais e outras disposições da Directiva 1999/5/CE.
[sl]Slovensko [Slovenian]	[ <i>Ime proizvajalca</i> ] izjavlja, da je ta [ <i>tip opreme</i> ] v skladu z bistvenimi zahtevami in ostalimi relevantnimi določili direktive 1999/5/ES.
Slovensky [Slovak]	[ <i>Meno výrobcu</i> ] týmto vyhlasuje, že [ <i>typ zariadenia</i> ] spĺňa základné požiadavky a všetky príslušné ustanovenia Smernice 1999/5/ES.
[fi]Suomi [Finnish]	[ <i>Valmistaja = manufacturer</i> ] vakuuttaa täten että [ <i>type of equipment = laitteen tyyppimerkintä</i> ] tyyppinen laite on direktiivin 1999/5/EY oleellisten vaatimusten ja sitä koskevien direktiivin muiden ehtojen mukainen.
[sv]Svenska [Swedish]	Härmed intygar [ <i>företag</i> ] att denna [ <i>utrustningstyp</i> ] står i överensstämmelse med de väsentliga egenskapskrav och övriga relevanta bestämmelser som framgår av direktiv 1999/5/EG.

## **Federal Communication Commission Interference Statement**

This device complies with Part 15 of the FCC Rules. Operation is subject to the following two conditions: (1) This device may not cause harmful interference, and (2) this device must accept any interference received, including interference that may cause undesired operation.

This equipment has been tested and found to comply with the limits for a Class B digital device, pursuant to Part 15 of the FCC Rules. These limits are designed to provide reasonable protection against harmful interference in a residential installation. This equipment generates, uses and can radiate radio frequency energy and, if not installed and used in accordance with the instructions, may cause harmful interference to radio communications. However, there is no guarantee that interference will not occur in a particular installation. If this equipment does cause harmful interference to radio or television reception, which can be determined by turning the equipment off and on, the user is encouraged to try to correct the interference by one of the following measures:

- Reorient or relocate the receiving antenna.
- Increase the separation between the equipment and receiver.
- Connect the equipment into an outlet on a circuit different from that to which the receiver is connected.
- Consult the dealer or an experienced radio/TV technician for help.

FCC Caution: Any changes or modifications not expressly approved by the party responsible for compliance could void the user's authority to operate this equipment.

This transmitter must not be co-located or operating in conjunction with any other antenna or transmitter.

### **Radiation Exposure Statement:**

This equipment complies with FCC radiation exposure limits set forth for an uncontrolled environment. This equipment should be installed and operated with minimum distance 20cm between the radiator & your body.