



PLEASE CHECK FOR CHANGE INFORMATION  
AT THE REAR OF THIS MANUAL.

**AA 5001  
PROGRAMMABLE  
DISTORTION  
ANALYZER**

PRELIMINARY

INSTRUCTION MANUAL

Tektronix, Inc.  
P.O. Box 500  
Beaverton, Oregon 97077

070-4598-00  
Product Group 76

Serial Number \_\_\_\_\_

First Printing OCT 1983

Copyright © 1983 Tektronix, Inc. All rights reserved.  
Contents of this publication may not be reproduced in any  
form without the written permission of Tektronix, Inc.

Products of Tektronix, Inc. and its subsidiaries are covered  
by U.S. and foreign patents and/or pending patents.



TEKTRONIX, TEK, SCOPE-MOBILE, and  are  
registered trademarks of Tektronix, Inc. TELEQUIPMENT  
is a registered trademark of Tektronix U.K. Limited.

Printed in U.S.A. Specification and price change privileges  
are reserved.

TABLE OF CONTENTS

|                                | Page |
|--------------------------------|------|
| LIST OF ILLUSTRATIONS.....     | . vi |
| LIST OF TABLES.....            | .vii |
| OPERATOR'S SAFETY SUMMARY..... | viii |
| SERVICE SAFETY SUMMARY.....    | . x  |

Section 1 SPECIFICATION

|                                    |      |
|------------------------------------|------|
| Instrument Description.....        | 1-1  |
| Performance Conditions.....        | 1-1  |
| Electrical Characteristics.....    | 1-3  |
| Environmental Characteristics..... | 1-15 |
| Physical Characteristics.....      | 1-17 |

Section 2 OPERATING INSTRUCTIONS

|  |      |
|--|------|
| Preparation for Use.....                     | 2-1  |
| Repackaging Information.....                 | 2-2  |
| Controls, Connectors, and Indicators.....    | 2-3  |
| Instrument Connections.....                  | 2-8  |
| Level Measurements.....                      | 2-10 |
| Distortion Measurements.....                 | 2-11 |
| Distortion Measurement Procedure.....        | 2-14 |
| High Distortion Measurement Limitations..... | 2-16 |
| IM Distortion Measurement Procedure.....     | 2-16 |
| Filters.....                                 | 2-20 |
| Displays.....                                | 2-24 |
| Monitoring.....                              | 2-24 |

## TABLE OF CONTENTS (cont)

## Section 3 PROGRAMMING

|  |      |
|--|------|
| Introduction.....                                  | 3-1  |
| GPIB Address and Terminator Setting.....           | 3-2  |
| COMMANDS.....                                      | 3-4  |
| Instrument Commands.....                           | 3-4  |
| DETAILED COMMAND LIST.....                         | 3-9  |
| Settling Algorithm.....                            | 3-31 |
| Remote Local Exceptions.....                       | 3-32 |
| MESSAGES AND COMMUNICATION PROTOCOL                |      |
| Command Separator.....                             | 3-33 |
| Message Terminator.....                            | 3-33 |
| Formatting A Message.....                          | 3-33 |
| Number Formats.....                                | 3-36 |
| Rounding of Numeric Arguments.....                 | 3-37 |
| Message Protocol.....                              | 3-37 |
| Multiple Messages.....                             | 3-38 |
| INSTRUMENT RESPONSE TO IEEE-488 INTERFACE MESSAGES |      |
| UNL - Unlisten, UNT - Untalk.....                  | 3-39 |
| IFC - Interface Clear.....                         | 3-40 |
| DCL - Device Clear.....                            | 3-40 |
| SDC - Selected DeviceClear.....                    | 3-40 |
| GET - Group Execute Trigger.....                   | 3-40 |
| SPE - Serial Poll Enable                           |      |
| SPD - Serial Poll Disable.....                     | 3-40 |
| MLA - My Listen Address, MTA - My Talk Address...  | 3-40 |
| LLO - Local Lockout.....                           | 3-41 |
| REN - Remote Enable.....                           | 3-41 |
| GTL - Go To Local.....                             | 3-41 |
| Talked With Nothing To Say Response.....           | 3-41 |
| Remote-Local Operation.....                        | 3-41 |
| Local State (LOCS).....                            | 3-42 |
| Local With Lockout State (RWLS).....               | 3-42 |











## TABLE OF CONTENTS (cont)

|  |      |
|--|------|
| Remote State (REMS).....                 | 3-42 |
| Remote With Lockout State (RWLS).....    | 3-42 |
| STATUS AND ERROR REPORTING.....          | 3-42 |
| Power Up Conditions.....                 | 3-46 |
| The POLL Statement and Clearing SRQ..... | 3-47 |
| Information Available.....               | 3-47 |
| PROGRAMMING EXAMPLES.....                | 3-49 |

**WARNING**

THE FOLLOWING SERVICING INSTRUCTIONS ARE FOR USE BY QUALIFIED PERSONNEL ONLY. TO AVOID PERSONAL INJURY, DO NOT PERFORM ANY SERVICING OTHER THAN THAT CONTAINED IN OPERATING INSTRUCTIONS UNLESS YOU ARE QUALIFIED TO DO SO. REFER TO OPERATORS SAFETY SUMMARY AND SERVICE SAFETY SUMMARY PRIOR TO PERFORMING ANY SERVICE.

## Section 4 THEORY OF OPERATION

|  |      |
|--|------|
| Introduction.....  | 4-1  |
| Input Amplifier  .....  | 4-1  |
| Automatic Gain Control  .....                                   | 4-4  |
| Notch Filter  .....   | 4-5  |
| Frequency Band Discriminator  .....                            | 4-7  |
| Notch Filter Control  .....                                     | 4-9  |
| Distortion Amplifier  .....                                     | 4-11 |
| Filters and AC-DC Converters (Standard Instruments Only)  ..... | 4-12 |
| Filters and AC-DC Converters (Option 02 Only)  .....            | 4-14 |
| dB Converter  .....   | 4-16 |
| dB Offset Generator  .....                                      | 4-17 |

## TABLE OF CONTENTS (cont)

|  |      |
|--|------|
| dB Ratio Circuitry <span style="border: 1px solid black; padding: 0 2px;">7</span> .....   | 4-17 |
| 6 V Reference <span style="border: 1px solid black; padding: 0 2px;">7</span> .....  | 4-18 |
| Dvm <span style="border: 1px solid black; padding: 0 2px;">8</span> .....  | 4-18 |
| Display Board <span style="border: 1px solid black; padding: 0 2px;">9</span> .....  | 4-19 |
| Logic Circuitry <span style="border: 1px solid black; padding: 0 2px;">10</span> <span style="border: 1px solid black; padding: 0 2px;">11</span> <span style="border: 1px solid black; padding: 0 2px;">12</span> ..... | 4-19 |
| Power Supplies <span style="border: 1px solid black; padding: 0 2px;">13</span> .....  | 4-22 |
| Interface.....   | 4-23 |
| IM Analyzer .....  | 4-24 |
| GPIB Circuitry.....  | 4-26 |

**Section 5 CALIBRATION****PERFORMANCE CHECK**

|  |      |
|--|------|
| Introduction.....                      | 5-1  |
| Performance Check Interval.....        | 5-1  |
| Services Available.....                | 5-1  |
| Test Equipment Required.....           | 5-2  |
| Performance Check Steps.....           | 5-4  |
| AA 5001 Performance Check Summary..... | 5-5  |
| PERFORMANCE CHECK PROCEDURES.....      | 5-10 |

**ADJUSTMENT PROCEDURE**

|                              |      |
|------------------------------|------|
| Introduction.....            | 5-33 |
| Test Equipment Required..... | 5-33 |
| Preparation.....             | 5-34 |
| PROCEDURE.....               | 5-35 |

**Section 6 MAINTENANCE**

|  |     |
|--|-----|
| Introduction.....                          | 6-1 |
| Preparation For Use.....                   | 6-1 |
| On-board Jumpers.....                      | 6-1 |
| REAR INTERFACE INFORMATION                 |     |
| FUNCTIONS AVAILABLE AT REAR CONNECTOR..... | 6-2 |
| GENERAL MAINTENANCE INFORMATION            |     |

## TABLE OF CONTENTS (cont)

|   |          |
|---|----------|
| Troubleshooting Aids.....                                     | 6-6      |
| Circuit Board Illustrations.....                              | 6-6      |
| Calibration Fixtures.....                                     | 6-6      |
| Troubleshooting Equipment.....                                | 6-6      |
| Static-Sensitive Components.....                              | 6-7      |
| Obtaining Replacement Parts.....                              | 6-9      |
| Circuit Board Removal.....                                    | 6-11     |
| Magnetic Shield.....  | 6-15     |
| Soldering Techniques.....                                     | 6-15     |
| <br>Semiconductors.....                                       | <br>6-16 |
| Coaxial Cables.....   | 6-17     |
| Exterior Cleaning.....  | 6-17     |
| Interior Cleaning.....  | 6-17     |
| <b>GPIB ADDRESS AND MESSAGE TERMINATOR SWITCHES</b>           |          |
| Setting the GPIB Address Switches.....                        | 6-18     |
| Setting the Message Terminator Switch.....                    | 6-21     |
| <b>TROUBLESHOOTING INFORMATION</b>                            |          |
| Introduction.....   | 6-21     |
| Hardware Tests.....   | 6-22     |
| Signature Analysis.....                                       | 6-23     |
| Troubleshooting High Residual<br>Distortion Problems.....     | 6-24     |
| <br><b>Section 6 OPTIONS</b>                                  |          |
| <br><b>Section 7 REPLACEABLE ELECTRICAL PARTS</b>             |          |
| <br><b>Section 8 DIAGRAMS AND CIRCUIT BOARD ILLUSTRATIONS</b> |          |
| Adjustment Locations  |          |
| Component Reference Charts                                    |          |
| Schematic Diagrams  |          |

## TABLE OF CONTENTS (cont)

## Section 9 REPLACEABLE MECHANICAL PARTS

Fig. 1 Exploded View  
Accessories

## CHANGE INFORMATION

## LIST OF ILLUSTRATIONS

| Fig. No.   |  | Page |
|------------|--|------|
| Fig. 2-1.  | Installation and removal. ....   | 2-1  |
| Fig. 2-2.  | Front panel controls and connectors. ....  | 2-4  |
| Fig. 2-3.  | Typical connections for distortion measurements.   |      |
| See text.  | .....  | 2-9  |
| Fig. 2-4.  | Block diagram of a basic harmonic distortion analyzer .....                                      | 2-12 |
| Fig. 2-5.  | Transfer characteristics of an audio device. ....  | 2-13 |
| Fig. 2-6.  | THD test of transfer characteristics. ....   | 2-14 |
| Fig. 2-7.  | Block diagram of basic IM analyzer. ....   | 2-17 |
| Fig. 2-8.  | IM test of transfer characteristics in time and frequency domain. ....                           | 2-18 |
| Fig. 2-9.  | Response curves for AA 5001 filters. ....  | 2-21 |
| Fig. 2-10. | Oscilloscope display of deviation from linearity.  | 2-26 |
| Fig. 3-1.  | AA 5001 commands and relationships to front panel controls. See command lists for descriptions.. | 3-3  |
| Fig. 3-2.  | ASCII and IEEE 488 (GPIB) code chart.....  | 3-35 |
| Fig. 3-3.  | Definition of status bytes .....   | 3-43 |
| Fig. 4-1.  | Simplified notch filter .....  | 4-5  |
| Fig. 4-2.  | Frequency band discriminator .....   | 4-8  |
| Fig. 4-3.  | Intermodulation distortion analyzer block diagram  | 4-24 |
| Fig. 5-1.  | AA 5001 grounded unbalanced input connection .....   | 5-10 |
| Fig. 5-2.  | AA 5001 common mode input connection .....   | 5-12 |
| Fig. 5-3.  | AA 5001 check/adjust setup. ....   | 5-22 |
| Fig. 5-4.  | AA 5001 top cover adjustments access. ....   | 5-34 |
| Fig. 6-1.  | Main board rear interface connector assignments.   | 6-3  |
| Fig. 6-2.  | GPIB board rear interface connector assignments.   | 6-4  |
| Fig. 6-3.  | Circuit boards and connectors pictorial (top view).  | 6-10 |



|  |      |
|--|------|
| Fig. 6-4. Latch assembly pictorial. ....                     | 6-12 |
| Fig. 6-5. GPIB address and message terminator switches. .... | 6-19 |

## LIST OF TABLES

| Table No. |   | Page |
|-----------|---|------|
| 1-1       | Electrical Characteristics .....  | 1-4  |
| 1-2       | Environmental Characteristics .....   | 1-15 |
| 1-3       | Physical Characteristics .....  | 1-17 |
| 2-1       | Gains from INPUT terminals to FUNCTION OUTPUT connector<br>for various settings of the INPUT LEVEL RANGE control .. | 2-25 |
| 3-1       | Error query and status information .....  | 3-44 |
| 3-2       | Power on settings.....  | 3-46 |
| 4-1       | Truth table for U2042 outputs .....   | 4-9  |
| 4-2       | Internal connections in U1010 depending on logic states<br>of pins 10 and 11 .....                                  | 4-11 |
| 4-3       | Gain and switching through U2031 .....  | 4-12 |
| 4-4       | Truth table for U2021 .....   | 4-13 |
| 5-1       | Suggested test equipment .....  | 5-2  |
| 5-2       | Common mod rejection check .....  | 5-13 |
| 6-1       | Relative susceptibility to static discharge damage ....   | 6-8  |
| 6-2       | IEEE 488 (GPIB) primary addresses .....   | 6-20 |
| 6-3       | Front panel error display power-on self tests .....   | 6-22 |
| 6-4       | High distortion/noise symptoms and probable causes .....  | 6-26 |

## OPERATORS SAFETY SUMMARY

This general safety information is for both operating and servicing personnel. Specific warnings and cautions will be found throughout the manual where they apply, but may not appear in this summary.

### TERMS

#### In This Manual

CAUTION statements identify conditions or practices that can result in damage to the equipment or other property.

WARNING statements identify conditions or practices that can result in personal injury or loss of life.

#### As Marked on Equipment

CAUTION indicates a personal injury hazard not immediately accessible as one reads the marking, or a hazard to property including the equipment itself.





DANGER indicates a personal injury hazard immediately accessible as one reads the marking.

### SYMBOLS

#### In This Manual

 This symbol indicates where applicable cautionary or other information is to be found.

#### As Marked on Equipment

-  DANGER--High voltage.
-  Protective ground (earth) terminal.
-  ATTENTION--refer to manual.
-  Refer to manual

i

**Power Source**

This product is designed to operate from a power module that does not apply more than 250 volts rms between the supply conductors or between either supply conductor and ground. A protective ground connection by way of the grounding conductor in the power cord is essential for safe operation.

**Grounding The Product**

This product is grounded through the grounding conductor of the power module power cord. To avoid electrical shock, plug the power cord into a properly wired receptacle before connecting to the product input or output terminals. A protective ground connection by way of the grounding conductor in the power cord is essential for safe operation.

**Danger Arising From Loss of Ground**

Upon loss of the protective-ground connection, all accessible conductive parts (including knobs and controls that may appear to be insulating) can render an electric shock.

**Use the Proper Power Cord**

Use only the power cord and connector specified for your product.

Use only a power cord that is in good condition.

Refer cord and connector changes to qualified service personnel.

**Use The Proper Fuse**

To avoid fire hazard, use only the fuse specified in the parts list for your product, and which is identical in type, voltage rating and current rating.

Refer fuse replacement to qualified service personnel.

**Do Not Operate in Explosive Atmospheres**

To avoid explosion, do not operate this product in an atmosphere of explosive gases unless it has been specifically certified for such operation.

**Do Not Operate Plug-In Unit Without Covers**

To avoid personal injury, do not operate this product without covers or panels installed. Do not apply power to the plug-in via a plug-in extender.

**SERVICING SAFETY SUMMARY**

FOR QUALIFIED SERVICE PERSONNEL ONLY

Refer also to the preceding Operators Safety Summary

**Do Not Service Alone**

Do not perform internal service or adjustment of this product unless another person capable of rendering first aid and resuscitation is present.

**Use Care When Servicing With Power On**

Dangerous voltages may exist at several points in this product. To avoid personal injury, do not touch exposed connections and components while power is on.

Disconnect power before removing protective panels, soldering, or replacing components.

**Do Not Wear Jewelry**

Remove jewelry prior to servicing. Rings, necklaces, and other metallic objects could come into contact with dangerous voltages and currents.

**Power Source**

This product is intended to operate from a power module that will not apply more than 250 volts rms between the supply conductors or between either supply conductor and ground. A protective ground connection by way of the grounding conductor in the power cord is essential for safe operation.

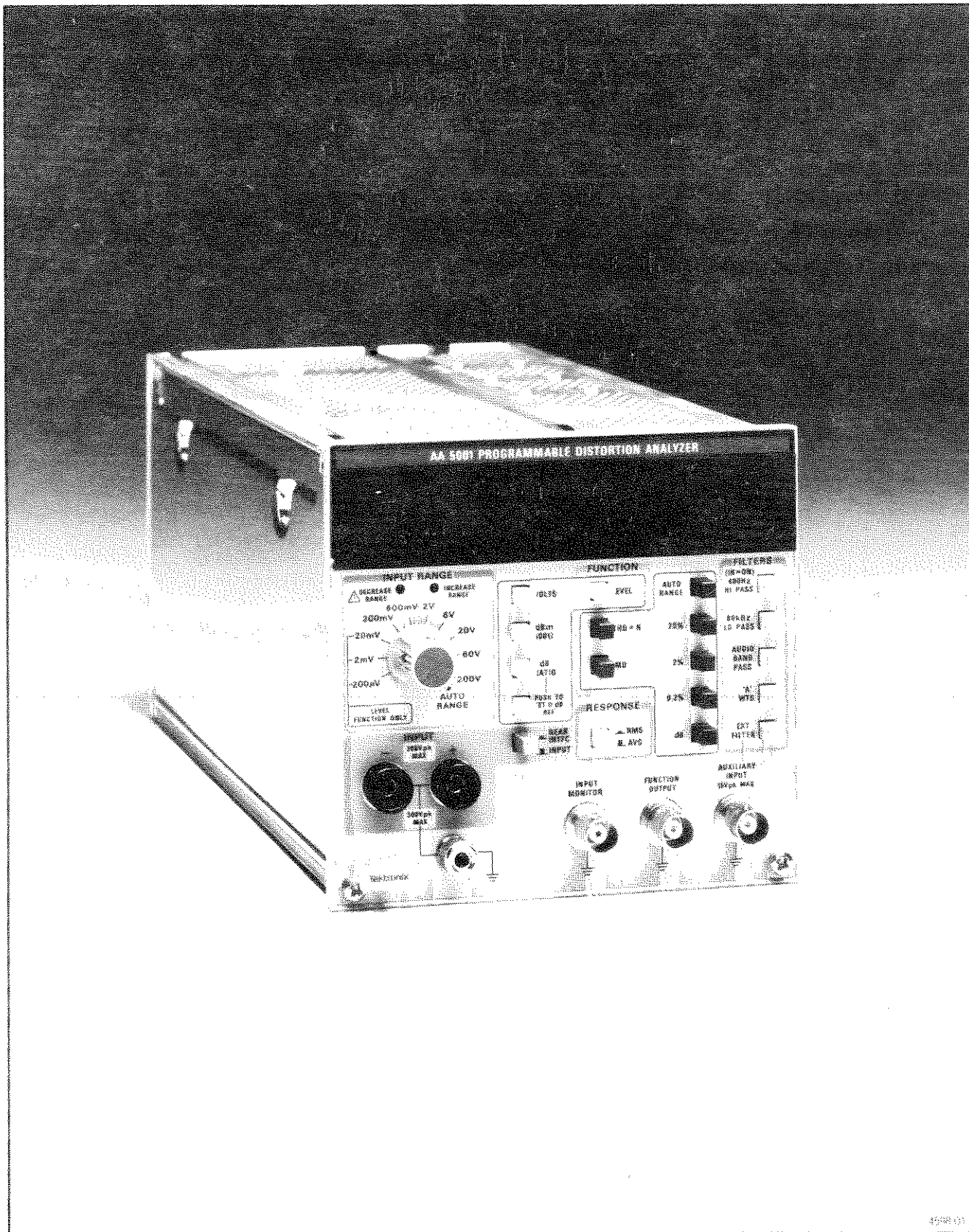

AA 5001 Programmable Distortion Analyzer.

## AA 5001 -- PRELIMINARY

### SPECIFICATION

#### Instrument Description

The AA 5001 is a fully automatic programmable distortion analyzer, packaged as a two-wide TM 5000 plug-in. Total harmonic distortion, SMPTE/DIN intermodulation distortion and CCIF two-tone difference frequency distortion are measured. Distortion set level, frequency tuning and nulling are fully automatic, requiring no operator adjustment. Distortion readout is provided in percent or dB.

The AA 5001 is also a high sensitivity, autoranging, audio frequency voltmeter. Readings may be in volts, dBm, or dB relative to any arbitrary reference.

Filters are included which allow bandwidth limiting or weighted measurement of noise. A hum rejection filter is also provided as are provisions for an external filter.

All readings are displayed on a 3 1/2 digit readout and can be remotely sent. An uncalibrated analog readout is also provided to aid in manual nulling and peaking applications. Ac to dc detection (response) is either true rms or average (quasi-peak in Option 02 instruments).

Ac input and output connections are available on both the front panel and the rear interface. Dc signals, corresponding to the displayed reading, are available through the rear interface. This allows flexibility in interconnection with other instruments such as filters, chart recorders, spectrum analyzers, oscilloscopes, etc.

#### Performance Conditions

The electrical characteristics in this specification are valid only if the AA 5001 has been adjusted at an ambient temperature between +20 degrees C and +30 degrees C. The instrument must be in a noncon-

condensing environment whose limits are described under the environmental part. Allow twenty minutes warm-up time for operation to specified accuracy; sixty minutes after exposure to or storage in a high humidity (condensing) environment. Any conditions that are unique to a particular characteristic are expressly stated as part of that characteristic.

The electrical and environmental performance limits, together with their related validation procedures, comprise a complete statement of the electrical and environmental performance of a calibrated instrument.

Items listed in the Performance Requirements column of the Electrical Characteristics are verified by completing the Performance Check in the Calibration section of this manual. Items listed in the Supplemental Information column are not verified in this manual.



Table 1-1  
ELECTRICAL CHARACTERISTICS

| Characteristics       | Performance Requirement  | Supplemental Information  |
|-----------------------|--|---|
| INPUT (all functions) |  |   |
| Impedance             | 100k ohms, $\pm 2\%$ , each side to ground                           | Full differential. Each side ac coupled through 1 $\mu$ F and shunted to ground by approximately equal to 200 pF. Dual banana jack connectors at 0.750 inch spacing with ground connector additionally provided.  |
| Input ranges          | 200 $\mu$ V to 200 V in 10 steps (2-6 sequence from 200 mV to 200 V) | Range selection is manual or automatic. Auto-ranging time is typically < 1 second. Separate increase range and decrease range indicators illuminate whenever input level does not fall within optimum window for selected range. For specified instrument performance both indicators must be extinguished. |
| Maximum input voltage |  | 300 V peak, 200 V rms either input to ground or differentially. Will recover without damage from continuous overloads of 120 V rms or 200 V rms for 30 minutes on all ranges. For linear response, peak input voltage must not exceed 3 times INPUT RANGE setting.  |

Table 1-1  
ELECTRICAL CHARACTERISTICS  
(cont)

| Characteristics  | Performance Requirement  | Supplemental Information  |
|--|--|---|
| Common mode rejection<br>(Inputs shorted)                  | > 50 dB at 50 or 60 Hz<br>for common mode signals<br>up to one-half of se-<br>lected input range or 50<br>mV, whichever is<br>greater. | Typically > 40 dB to 300<br>kHz.  |
| <b>LEVEL FUNCTION</b>                                      |  |   |
| Modes  |  | Volts, dBm (600 ohms), or<br>dB ratio with push to set<br>0 dB reference. Input<br>range determines display<br>range. Single effective<br>range in dB modes with<br>0.1 dB resolution.<br>Stored 0 dB reference is<br>unaffected by subsequent<br>changes in mode or func-<br>tion. |
| Accuracy (level rang-<br>ing indicators extin-<br>guished) |  |   |
|  | Volts  | dB modes  |
| 20 Hz to 20 kHz  | Within +2%<br>+1 count   | +0.3 dB <sup>1</sup><br>+0.5% of<br>reading   |
| 10 Hz to 100 kHz   | Within +4%<br>+2 counts  | +0.5 dB <sup>1</sup><br>+0.5% of<br>reading   |

<sup>1</sup>+0.2 dB at 1 kHz only. Flatness is +0.1 dB, 20 Hz to 20 kHz, and +0.3 dB, 10 Hz to 100 kHz.

Table 1-1  
ELECTRICAL CHARACTERISTICS  
(cont)

| Characteristics   | Performance Requirement  | Supplemental Information   |
|---|--|--|
| Bandwidth (no filters selected)                                       | At least 300 kHz.  |  |
| Residual noise (Inputs shorted, $T_{\leq 40}$ degrees C)              | <p><math>&lt; 3.0 \text{ uV (-108 dBm)}</math> with 80 kHz, 400 Hz filters.</p> <p><math>&lt; 1.5 \text{ uV (-114 dBm)}</math> with A weighting filter. (Standard instrument only).</p> <p><math>&lt; 5.0 \text{ uV (-104 dBm)}</math> with CCIR weighting and quasi-peak response. (Option 2 only).</p> |  |
| <b>TOTAL HARMONIC DISTORTION PLUS NOISE FUNCTION</b><br><br>Operation |  | <p>Fully automatic notch filter tuning and nulling for valid test signals with 10% or less THD + N.</p> <p>Midband signal THD + N can degrade to 30% without loss of lock following initial tuning for SINAD testing.</p> <p>Typical or average measurement settling time is 2.5 seconds above 100 Hz increasing by approximately 1 sec/octave below 100 Hz.</p> |

Table 1-1  
ELECTRICAL CHARACTERISTICS  
(cont)

| Characteristics  | Performance Requirement                                       | Supplemental Information  |
|--|---|---|
| Fundamental frequency range                                    | 10 Hz to 100 kHz  |   |
| Minimum input level  | 60 mV (-22 dBm)   |   |
| Accuracy   |   | Autoranging % or dB modes only. 100% reference level is total input signal amplitude including distortion and noise components. Accuracy may also be limited by the effects of residual THD + N and filter selection. |
| 20 Hz to 20 kHz  | Within $\pm 10\%$ ( $\pm 1$ dB) for harmonics $\leq 100$ kHz. |   |
| 10 Hz to 100 kHz   | Within $\pm 20\%$ ( $\pm 2$ dB) for harmonics $\leq 300$ kHz. |   |
| Residual THD+N ( $V_{in} \geq 250$ mV, $T \leq +40$ degrees C) |   | System specification with any SG 5010 or SG 505 oscillator, all distortion, noise, and nulling error sources combined.  |
| 20 Hz to 20 kHz with 80 kHz noise limiting filter              | $< 0.0032\%$<br>(-90 dB)                                      |   |
| 10 Hz to 100 kHz, no filter                                    | $< 0.010\%$<br>(-80 dB)                                       |   |

Table 1-1  
ELECTRICAL CHARACTERISTICS  
(cont)

| Characteristics   | Performance Requirement  | Supplemental Information   |
|---|--|--|
| Typical fundamental rejection                                 |  | At least 10 dB below specified residual THD+N or the actual signal THD, whichever is greater.  |
| <b>INTERMODULATION DISTORTION FUNCTION</b>                    |  |  |
| Operation   |  | Fully automatic SMPTE/DIN or CCIF difference tone test selection depending upon actual input signal whenever respective $IMD \leq 20\%$ . Typical or average measurement settling time is 2 sec or less. |
| SMPTE and DIN tests   |  |  |
| Frequency range (upper tone)                                  |  | Useable from 3 kHz to beyond 100 kHz   |
| IM frequency range (lower tone)                               |  | 50 Hz to 250 Hz  |
| Level ratio range   |  | 1:1 to 4:1 (lower:upper)   |
| Residual IMD ( $V_{in} \geq 250$ mV, $T \leq +40$ degrees C.) | $\leq .0032\%$ (-90 dB) with 60 Hz and 7 kHz or 250 Hz and 8 kHz test tones. | System specification with any SG 5010 oscillator or passively summed SG 505 oscillator pair.   |

Table 1-1  
ELECTRICAL CHARACTERISTICS  
(cont)

| Characteristics  | Performance Requirement   | Supplemental Information   |
|--|---|--|
| CCIF difference tone test                                  |   |  |
| Frequency range  |   | Useable from 4 kHz to beyond 100 kHz   |
| Difference frequency range                                 |   | 80 Hz to 1 kHz   |
| Residual IMD ( $V_{in} > 250$ mV, $T \leq +40$ degrees C.) | $< 0.0018\%$ (-95 dB) with 14 kHz and 15 kHz test tones.        | System specification with any SG 5010 oscillator or passively summed SG 505 oscillator pair.                       |
| Minimum input level  | 60 mV (-22 dBm)   |  |
| Accuracy   | Within $\pm 10\%$ ( $\pm 1$ dB) for IM components $\leq 1$ kHz  | Autorangeing % or dB modes only. Accuracy may also be limited by the effects of residual IMD and filter selection. |
| <b>FILTERS</b>   |   |  |
| 400 Hz high pass   | -3 dB at 400 Hz, $\pm 5\%$ ; at least -40 dB rejection at 60 Hz | 3 pole Butterworth response  |
| 80 kHz low pass  | -3 dB at 80 kHz, $\pm 5\%$                                      | 3 pole Butterworth response  |

Table 1-1  
ELECTRICAL CHARACTERISTICS  
(cont)

| Characteristics                        | Performance Requirement                                  | Supplemental Information   |
|--|--|--|
| Audio bandpass                         | -3 dB at 22.4 Hz, <u>+5%</u><br>and 22.4 kHz, <u>+5%</u> | Within specifications of CCIR Recommendation 468-2 and DIN 45405 for un-weighted measurement response.   |
| A weighting (standard instrument only) |  | Within specifications for type 1 sound level meters listed in ANSI S 1.4 1971 (revised 1976) and IEC Recommendation 179.   |
| CCIR WTG (Option 2 only)               |  | Within specifications of CCIR recommendation 468-2 and DIN 45405 for noise measurements with quasi-peak detector. Rms detector calibration shifted for 0 dB at 2.00 kHz instead of 1.00 kHz. |
| External Filter                        |  | Selects front panel AUXILIARY INPUT allowing connection of external filter between it and FUNCTION OUTPUT.   |

Table 1-1  
ELECTRICAL CHARACTERISTICS  
(cont)

| Characteristics            | Performance Requirement                             | Supplemental Information  |
|----------------------------|---|---|
| <b>FRONT PANEL SIGNALS</b> |   |   |
| <b>INPUT MONITOR</b>       |   |   |
| Vin $\geq$ 50 mV           | 1 V rms, $\pm 10\%$                                 | Constant amplitude (average response) version of differential input signal. THD is typically $\leq$ 0.0010% (-100 dB) from 20 Hz to 20 kHz. |
| Vin < 50 mV                |   | Approximately 20 times input signal.  |
| Impedance                  | 1k ohms, $\pm 5\%$                                  |   |
| <b>FUNCTION OUTPUT</b>     |   |   |
| Signal                     | 1 V, $\pm 3\%$ , for 1000 count volts or % display. | Selected and filtered ac signal actually measured.  |
| Impedance                  | 1k ohms, $\pm 5\%$                                  |   |
| <b>AUXILIARY INPUT</b>     |   |   |
| Sensitivity                | 1 V, $\pm 3\%$ , for 1000 count volts or % display. | Loop through accuracy from FUNCTION OUTPUT is $\pm 3\%$ .   |
| Maximum Input Voltage      |   | 15 V peak, 6 V peak for linear response.  |
| Impedance                  | 100k ohms, $\pm 5\%$                                | Ac coupled.   |



Table 1-1  
ELECTRICAL CHARACTERISTICS  
(cont)

| Characteristics               | Performance Requirement | Supplemental Information   |
|-------------------------------|-------------------------|--|
| <b>REAR INTERFACE SIGNALS</b> |                         |  |
| Rear interface input          |                         | Pins 28B (+), 28A (-), 27B and 27A (common) are front panel selectable and independent of main front panel input. All characteristics are the same as main INPUT except maximum input voltage is limited to 42 V peak, 30 V rms. Due to potential crosstalk at the rear interface, noise and distortion performance may be degraded. |
| Input monitor                 |                         | Pins 24A and 23A (gnd) same as front panel FUNCTION OUTPUT.  |
| Function output               |                         | Pins 23B and 24B (gnd) same as front panel FUNCTION OUTPUT.  |
| Auxiliary input               |                         | Pins 25B and 26B (gnd) same as front panel AUXILIARY INPUT. Maximum input voltage is 15 V peak, 6 V peak for linear operation.   |
| AC/DC Converter output        |                         | Pins 20A and 19A (gnd). Dc output of the selected ac to dc converter. 1 V $\pm 5\%$ for 1000 count display with 500 ohms $\pm 5\%$ source resistance.  |

Table 1-1  
ELECTRICAL CHARACTERISTICS  
(cont)

| Characteristics  | Performance Requirement | Supplemental Information   |
|--|-------------------------|--|
| dB converter output  |                         | Pins 19B and 20B (gnd).<br>Dc output of the logarithmic dB converter. 10 mV $\pm$ 5% equals 1 dB of display with 1k ohms $\pm$ 5% source resistance.<br>Changes in level or distortion range will cause brief ac transients. |
| <b>DETECTORS AND DISPLAYS</b><br><br>Detectors (Response)<br><br>RMS<br><br>AVG (standard instrument only) |                         | True rms detection.<br><br>Average detection, rms calibrated for sinewaves. Typically reads 1 to 2 dB lower than true rms detection for noise, THD+N, and IMD measurements.  |

Table 1-1  
ELECTRICAL CHARACTERISTICS  
(cont)

| Characteristics  | Performance Requirement | Supplemental Information  |
|--|-------------------------|---|
| <p>Quasi-peak (Option 02 only)</p>                     |                         | <p>Quasi-peak detection, rms calibrated for sinewaves. Within specifications of CCIR Recommendation 468-2 and DIN 45405. Due to the peak hold nature of its response readings, considerably higher than rms response will occur with large crest factor signals (such as noise). The input range indicators should be ignored and auto-ranging avoided with these types of signals.</p> |
| <p>Displays</p> <p>Digital</p> <p>Analog bar graph</p> |                         | <p>3 1/2 digit, 2000 count LED. Overrange indication is 1, blank, blank, blank.</p> <p>10 segment LED intensity modulated bar graph display of digital readout. Segments are logarithmically activated with approximately 2.5 dB/segment.</p>   |

Table 1-1  
ELECTRICAL CHARACTERISTICS  
(cont)

| Characteristics                 | Performance Requirement | Supplemental Information   |
|---------------------------------|-------------------------|--|
| <b>MISCELLANEOUS</b>            |                         |  |
| Power consumption               |                         | Approximately 24 watts   |
| Internal Power Supplies         |                         |  |
| +15                             |                         | Nominally +15.1 V, $\pm 3\%$                                       |
| -15                             |                         | Nominally -15.1 V, $\pm 5\%$                                       |
| +5                              |                         | Nominally +5.25 V, $\pm 2\%$                                       |
| Fuse Data                       |                         |  |
| F1610                           |                         | 3 AG, 1 A, 250 V, fast blow  |
| F1620                           |                         | 3 AG, 1 A, 250 V, fast blow  |
| F1621                           |                         | 3 AG, 1 A, 250 V, fast blow  |
| Recommended adjustment interval |                         | 2000 hours or 12 months whichever occurs first                     |
| Warm-up time                    |                         | 20 minutes (60 minutes after storage in high humidity environment) |

Table 1-2  
<sup>1</sup>ENVIRONMENTAL CHARACTERISTICS

| Characteristics | Description  |
|-----------------|--|
| Temperature     | Meets MIL-T-28800B,<br>class 5.  |
| Operating       | 0 to +50 degrees C<br>-40 to +75 degrees C   |
| Nonoperating    |  |
| Humidity        | 95% RH, 0 to +30<br>degrees C      Meets MIL-T-28800B,<br>class 5.   |
|                 | 75% RH, to +40 de-<br>grees C  |
|                 | 45% RH, to +50 de-<br>grees C  |
| Altitude        | Exceeds MIL-T-28800B,<br>class 5.  |
| Operating       | 4.6 km (15,000 ft)   |
| Nonoperating    | 15 km (50,000 ft)  |
| Vibration       | 0.38 mm (0.015")      Meets MIL-T-28800B,<br>peak to peak, 5 Hz      class 5, when in-<br>to 55 Hz, 75 min-      stalled in qualified<br>utes.                      power modules. <sup>2</sup>                                    |
| Shock           | 30 g's (1/2 sine),      Meets MIL-T-28800B,<br>11 ms duration, 3      class 5, when in-<br>shocks in each di-      stalled in qualified<br>rection along 3 ma-      power modules. <sup>2 3</sup><br>jor axes, 18 total<br>shocks. |

<sup>1</sup>With TM 5000-Series power module. System performance subject to exceptions of power module or other individual plug-ins.

<sup>2</sup>Refer to power module specifications.

<sup>3</sup>Requires power module retainer bar or clip.

Table 1-2  
<sup>1</sup>ENVIRONMENTAL CHARACTERISTICS  
 (cont)

| Characteristics                                    | Description  |
|--|--|
| Bench Handling <sup>3</sup>                        | 12 drops from 45 degrees, 4" or equilibrium, whichever occurs first. Meets MIL-T-28800B, class 5.  |
| Package Product Vibration and Shock (Plug-in only) | Qualified under National Safe Transit Association Preshipment Test Procedure 1A-B-1 and 1A-B-2.  |
| Electromagnetic Interference                       | Within limits of F.C.C. Regulations, Part 15, Subpart J, Class A; and MIL-STD-461B (April 1, 1980) Class B.  |
| Electrostatic Immunity                             | At least 15 kV discharge from 500 pF in series with 100 ohms to instrument case or any front panel connector without damage or permanent performance degradation (Input terminals limited to 10 kV). |

<sup>1</sup>With TM 5000-Series power module. System performance subject to exceptions of power module or other individual plug-ins.

<sup>3</sup>Requires power module retainer bar or clip.

**Table 1-3**  
**PHYSICAL CHARACTERISTICS**

| Characteristics            | Description                               |
|----------------------------|---|
| Maximum Overall Dimensions |   |
| Height                     | 126.0 mm (4.96 inches)                    |
| Width                      | 131.2 mm (5.16 inches)                    |
| Length                     | 285.5 mm (11.24 inches)                   |
| Net Weight                 | Approximately equal to 2.04 kg (4.5 lbs.) |
| Finish                     |   |
| Front Panel                | Plastic-aluminum laminate                 |
| Chassis                    | Anodized aluminum                         |





AA 5001 -- PRELIMINARY

SECTION 2  
OPERATING INSTRUCTIONS

**Preparation For Use**

The AA 5001 is calibrated and ready for use when received. It operates in any two compartments of a TM 5000-Series power module. See the power module instruction manual for line voltage requirements and power module operation. Figure 2-1 shows the AA 5001 installation and removal procedure.

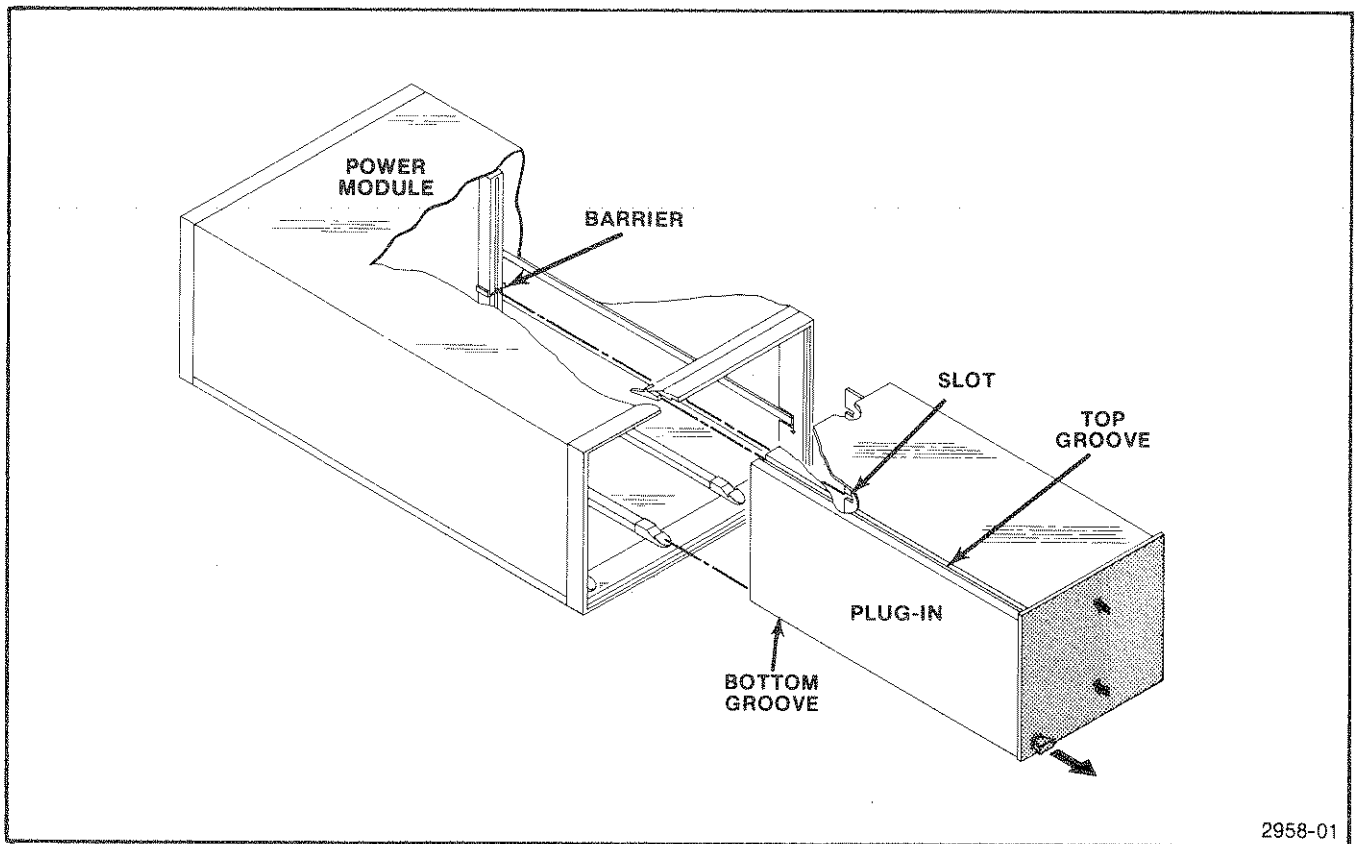

Fig. 2-1. Installation and removal

Check to see that the plastic barriers on the interconnecting jack of the selected power module compartment match the cutouts in the AA 5001 circuit board edge connector. Align the AA 5001 chassis with the upper and lower guides of the selected compartment. Press the AA 5001 in, to firmly seat the circuit board in the interconnecting jack.

**CAUTION**

Turn the power module off before inserting the AA 5001. Otherwise, arcing may occur at the rear interface connectors, reducing their useful life and damage may result to the plug-in circuitry.

To remove the AA 5001 pull the release latch (located in the lower left corner) until the interconnecting jack disengages and the AA 5001 slides out.

Check that the AA 5001 is fully inserted in the power module. Pull the power switch on the power module. One or more characters in the LED display should now be visible.

**NOTE**

The AA 5001 can be operated via the front panel or by commands sent over the GPIB by a suitable controller. This section discusses front panel operation. See the programming section of this manual for instrument operation via the GPIB.

**Repackaging Information**

If the Tektronix instrument is to be shipped to a Tektronix Service Center for service or repair, attach a tag showing the owner (with address) and the name of an individual at your firm that can be contacted. Include the complete instrument serial number and a description of the service required.

Save and reuse the package in which your instrument was shipped. If the original packaging is unfit for use or not available, repackage the instrument as follows:

Surround the instrument with polyethylene sheeting to protect the finish of the instrument. Obtain a carton of corrugated cardboard of the correct carton strength and having inside dimensions of no less than six inches more than the instrument dimensions. Cushion the instrument by tightly packing three inches of dunnage or urethane foam between carton and instrument on all sides. Seal the carton with shipping tape or an industrial stapler.

The carton test strength for this instrument is 200 pounds per square inch.

### **Controls, Connectors, and Indicators**

All controls, connectors and indicators (except for the rear interface connector) required for operation of the AA 5001 are located on the front panel. Fig. 2-2 provides a brief description of all front panel controls, connectors, and indicators.

- ① **INPUT RANGE**  
Selects input voltage range or AUTORANGE. The three most sensitive ranges operate in the LEVEL FUNCTION only. (The AA 5001 goes to AUTORANGE when in a remote state.)
- ② **DECREASE RANGE** !  
When this light is illuminated, reduce the INPUT LEVEL RANGE until the light goes out. If the FUNCTION selected is THD+N or IMD a flashing light indicates insufficient input signal level for distortion measurements.
- ③ **INCREASE RANGE**  
When this light is illuminated, increase the INPUT LEVEL RANGE until the light goes out.

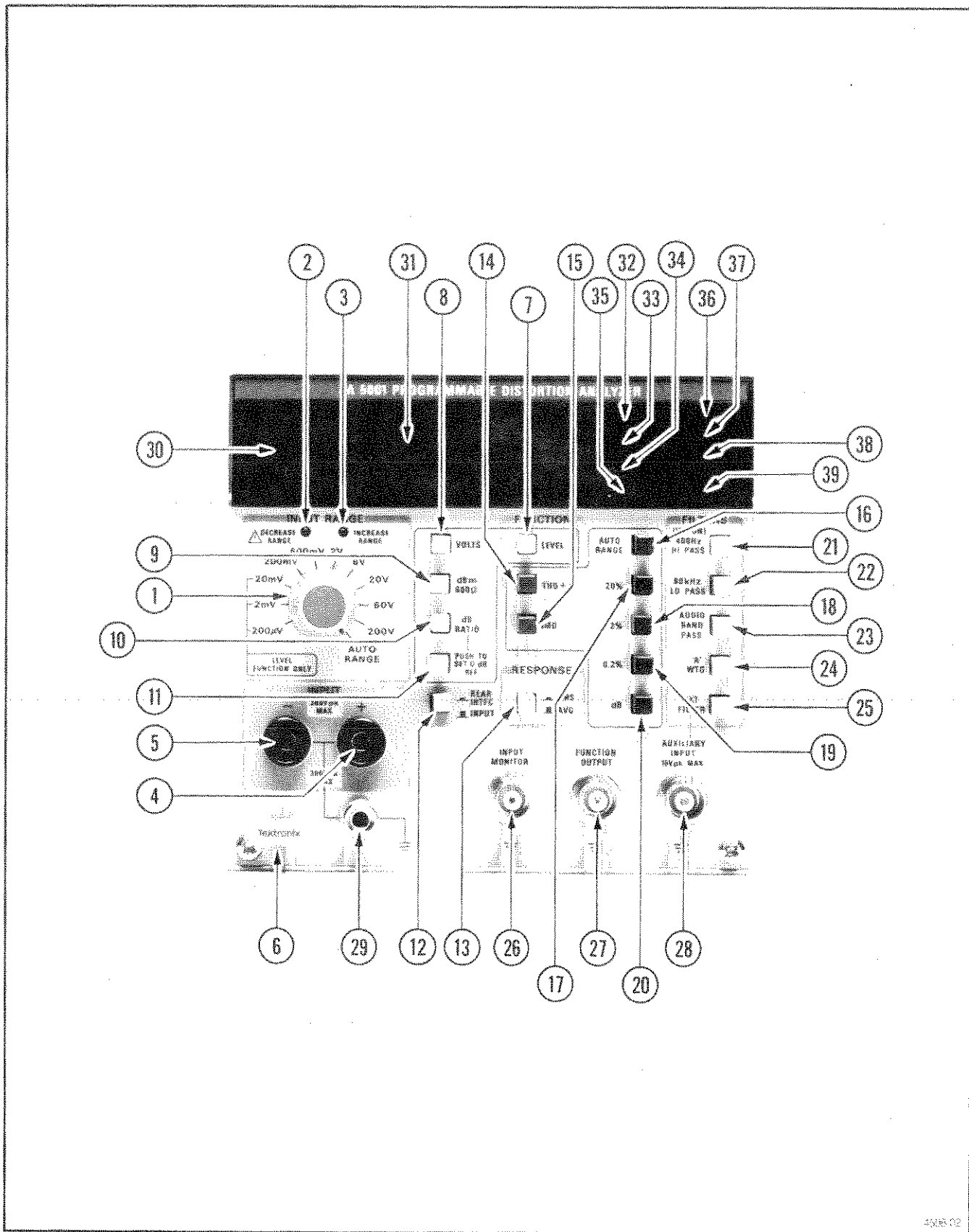

Fig. 2-2. Front panel controls and connectors.

- ④ **INPUT**  
Differential input terminal. Positive going input signal provides positive going output signal at INPUT MONITOR.
- ⑤ **INPUT**  
Differential input terminal. Negative going input signal provides positive going output at INPUT MONITOR.
- ⑥ **Release Latch**
- ⑦ **LEVEL**  
Button in selects input level measuring function.
- ⑧ **VOLTS**  
Button in selects voltage units for level function.
- ⑨ **dBm 600 ohms**  
Button in selects dBm units for level function. 0dB reference is 0.7746V corresponding to 1 mW into 600 ohms.
- ⑩ **dB RATIO**  
Button in selects dB ratio, with respect to preset level, as units for level function.
- ⑪ **PUSH TO SET 0 dB REF**  
Push button to set display to 0 with input signal applied to INPUT terminals in LEVEL function. dB RATIO and LEVEL pushbuttons must be in for this feature to operate.
- ⑫ **REAR INTFC-INPUT**  
Button in selects rear interface input; button out selects front panel input.
- ⑬ **RESPONSE**  
Button in gives RMS detection (responds to the rms value of the input waveform). Button out gives average detection or quasi-peak detection (option 02 instruments) both are rms calibrated for sinewaves.
- ⑭ **THD+N**  
Button in selects total harmonic distortion function.
- ⑮ **IMD**  
Button in selects intermodulation distortion function.
- ⑯ **AUTO RANGE**

Button in selects automatic distortion range selection (0.2% to 100% full scale). (The AA 5001 goes to AUTORANGE when in a remote state.)

- ①7    20%  
Button in selects full scale distortion readout of 20% with 0.01% resolution.
- ①8    2%  
Button in selects full scale distortion readout of 2% with 0.001% resolution.
- ①9    0.2%  
Button in selects full scale distortion readout of 0.2% with 0.0001% resolution.
- ②0    dB  
Selects single equivalent 0 dB to -100 dB distortion display range with 0.1 dB resolution.
- ②1    400 Hz HI PASS  
Button in connects filter before detector circuit in all functions.
- ②2    80 kHz LO PASS  
Button in connects filter before detector circuit in all functions.
- ②3    AUDIO BANDPASS  
Button in connects filter before detector circuit in all functions.
- ②4    "A" WEIGHTING (CCIR WEIGHTING In Option 02 Instruments)  
Button in connects filter before detector circuit in all functions.
- ②5    EXT FILTER  
Button in allows connection of external filter between FUNCTION OUTPUT and AUXILIARY INPUT in all functions.
- ②6    INPUT MONITOR  
Provides a buffered sample of the input signal.
- ②7    FUNCTION OUTPUT

Provides a sample of the selected FUNCTION signal additionally processed by selected filters.

- ②8 **AUXILIARY INPUT**  
Provides input to the detector circuit when the EXT FILTER button is pressed.
- ②9 **Ground**  
Provides front panel chassis ground connection.
- ③0 **LED Bar Graph**  
Provides approximate analog display of the digital display for nulling and peaking. Each segment represents approximately 2.5 dB.
- ③1 **Digital Display**  
3 1/2 digits. Overrange indication is a blanked display with the numeral 1 in the most significant digit position.
- ③2 **V**  
Illuminated when display units are volts.
- ③3 **mV**  
Illuminated when display units are millivolts.
- ③4 **uV**  
Illuminated when display units are microvolts.
- ③5 **%**  
Illuminated when display units are percent.
- ③6 **RMT**  
Illuminated when the AA 5001 is in the remote state or the remote with lockout state.
- ③7 **ADRS**  
Illuminated when the AA 5001 is talk or listen addressed.
- ③8 **dBm**  
Illuminated when display units are dBm.
- ③9 **dB**  
Illuminated when display units are dB.

## Instrument Connections

To make connections to the AA 5001, refer to Fig. 2-3. Connections can be made to the rear interface connector. However, low level or distortion measurements made through the rear interface may be degraded due to crosstalk. To measure signals connected to the front panel make certain the INPUT pushbutton is out. To select the rear interface signal input press the INPUT pushbutton.

**CAUTION**

**Maximum front panel input voltage is 300 V peak,  
200 V rms either input to ground or differential-  
ly. Maximum rear interface input is 42 V peak  
and 30 V rms.**

The AA 5001 input circuitry is protected against accidental overloading. This circuitry will recover without damage from continuous 120 V rms (30 minutes at 200 V rms) overloads in any INPUT RANGE setting.

In most cases, for maximum hum rejection, follow the cabling and grounding as shown in the figure. Shielded, twisted pair offers maximum hum and radio frequency interference rejection. Cable shielding, if used, should be grounded only at the AA 5001 front panel ground post. Use shielded cable to connect the output of an oscillator, external to the device under test, to the input of the device. Generally, to avoid possible ground loops, if the device under test has one side of the input grounded, float the output of the external oscillator. If the input to the device under test is floating (not chassis grounded) select the grounded mode for the output of the oscillator. Terminate the output of the device under test in its recommended load impedance, or the load impedance specified in the appropriate standard.



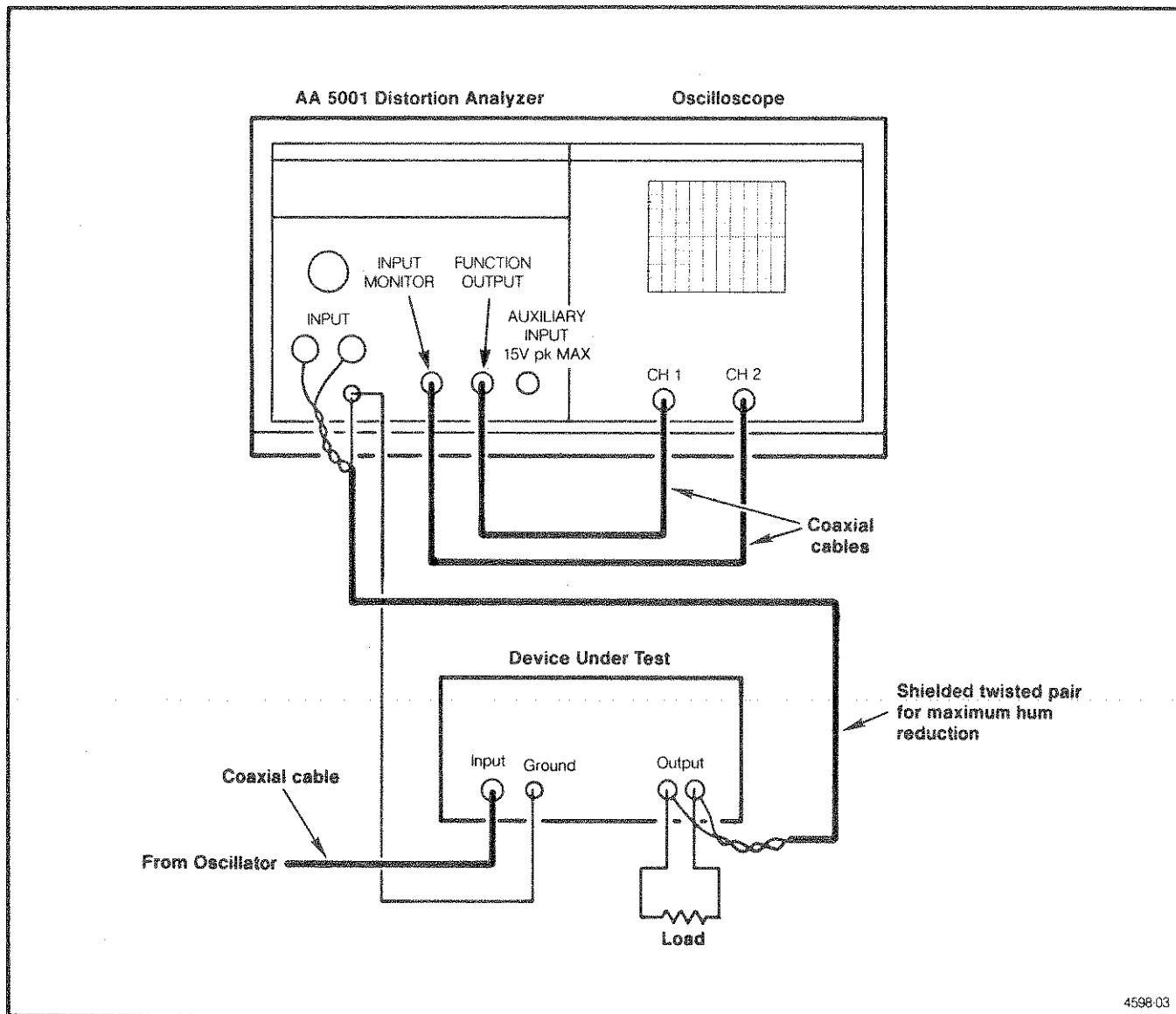

Fig. 2-3. Typical connections for distortion measurements. See text.

The illustration shows an optional oscilloscope for visual monitoring. If connected as shown channel 1 displays a sample of the input signal and channel 2 displays the distortion components when in the IM or THD+N function.

## Level Measurements

In the LEVEL function the AA 5001 operates as a wide band ac voltmeter. The Specification section of this manual contains the operating parameters. The meter is rms calibrated and either rms or average (quasi-peak in option 02 instruments) responding, depending on the position of the RESPONSE pushbutton.

Press the FUNCTION LEVEL pushbutton. The top three buttons to the left of the FUNCTION pushbuttons select readout units as VOLTS, dBm 600 ohms, or dB RATIO. For example, to measure voltage press the VOLTS pushbutton. If the INCREASE RANGE LED is illuminated, adjust the LEVEL RANGE control to the higher ranges until the LED goes out. (With the AA 5001 in the remote state, the INPUT RANGE automatically goes to the AUTO RANGE position irrespective of the actual switch position.) If the DECREASE RANGE LED is illuminated, turn the INPUT RANGE control counterclockwise until the DECREASE RANGE LED goes out. Readings are usable as long as the display is not overranged however for specified accuracy the DECREASE RANGE LED must also be off. Overrange is indicated by a blank display with the numeral 1 in the most significant digit slot.

If the INPUT RANGE switch is placed in the AUTO RANGE position, the input level is adjusted automatically. The LED's (VOLTS, mVOLTS or uVOLTS) automatically illuminate showing the proper display units. Notice that the three most sensitive ranges on the INPUT RANGE control operate in the LEVEL FUNCTION only.

When the dBm 600 ohms pushbutton is pressed, the LED opposite dBm on the display indicates the display units. The reference level for this measurement, 0 dBm, is 0.7746V corresponding to 1 mW dissipated in 600 ohms. The INPUT RANGE switch operates as previously described.

The dB RATIO mode permits direct amplitude ratio measurements of two input signals. When the dB RATIO pushbutton is pressed, the LED opposite the dB nomenclature on the display illuminates. To use this feature, press the dB RATIO pushbutton. To establish the input signal as 0 dB reference, push the PUSH TO SET 0 dB REF pushbutton and notice that the display reads all zeros. Release the 0 dB REF pushbutton. As the amplitude of the input signal is changed, the display reads the dB ratio of the input signal to the reference signal amplitudes.

There are many useful applications for the dB RATIO mode in measurements of gain-loss, frequency response, S/N ratio, etc. For example, the corner frequency of a filter may be quickly checked. Set the test frequency to some midband value and set the zero dB reference. Adjust the test frequency until the display reads -3.0 dB; this is the corner frequency of the filter.

Gain measurements may be simplified by using this feature. Set the device to be tested as desired and connect the AA 5001 input to the input of the device under test. Press the PUSH TO SET 0 dB REF pushbutton. Then connect the input of the AA 5001 to the device output and read the gain or loss directly from the display.

When measuring signal to noise ratio or making noise level measurements, it is often desirable to employ a frequency dependent weighting network. The AA 5001 provides several internal filters, as well as facilities for connecting external filters. For information on their operation and use, see the text under Filters in this section of this manual.

### **Distortion Measurements**

Distortion is a measure of signal impurity. It is usually expressed as a percentage or dB ratio of the undesired components to the desired components. Harmonic distortion is simply the presence of harmonically related or integral multiples of a single pure tone called the fundamental, and can be expressed for each particular harmonic.

Total harmonic distortion, or THD, expresses the ratio of the total power in all significant harmonics to that in the fundamental.

A distortion analyzer removes the fundamental of the signal investigated and measures the remainder. See Fig. 2-4. Because of the notch filter response, any signal other than the fundamental influences the measurement.

A total harmonic distortion measurement inevitably includes effects from noise or hum. The term THD+N has been recommended<sup>1</sup> to distinguish distortion measurements made with a distortion analyzer from those made with a spectrum analyzer. A spectrum analyzer allows direct measurement of each harmonic. However, it is relatively complex, time consuming, and requires interpretation of a graphic display.

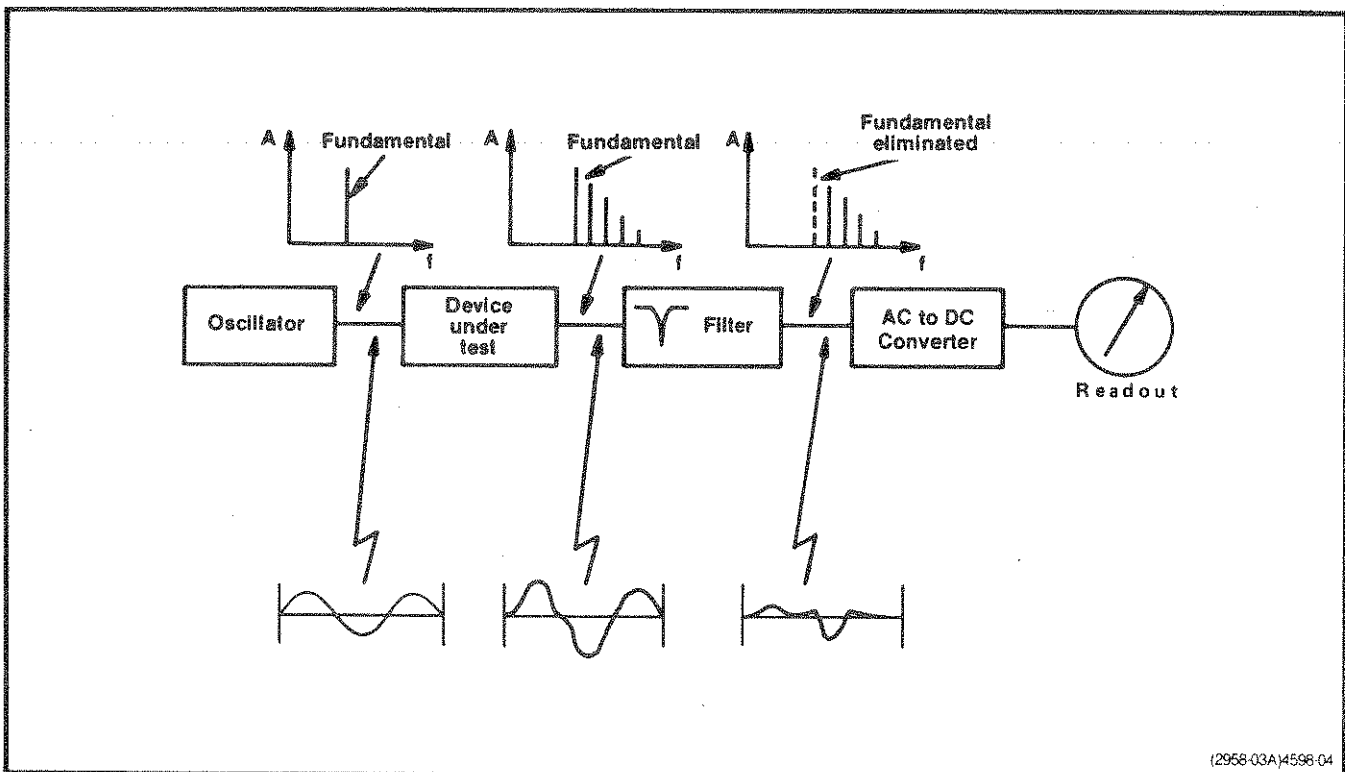

Fig. 2-4. Block diagram of a basic harmonic distortion analyzer.

<sup>1</sup>IHF-A-202 1978, Standard Methods of Measurement for Audio Amplifiers, The Institute of High Fidelity, Inc., 489 Fifth Avenue, New York, N.Y. 10017

Distortion analyzers can quantify the nonlinearity of a device or system. The transfer (input vs output) characteristic of a typical device is shown in Fig. 2-5. Ideally this is a straight line. A change in the input produces a proportional change in the output.

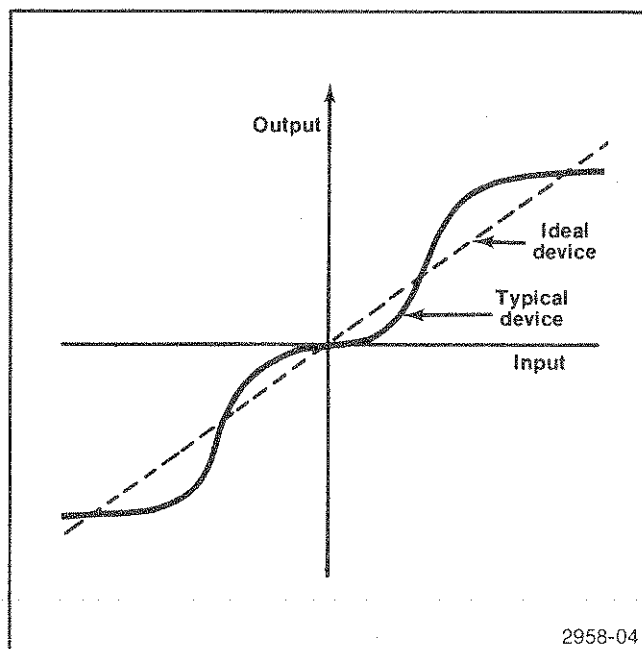

Fig. 2-5. Transfer characteristics of an audio device.

Since the actual transfer characteristic is nonlinear, a distorted version of the input waveshape appears at the output. The output waveform is the projection of the input sine wave on the device transfer characteristic as shown in Fig. 2-6. The output waveform is no longer sinusoidal, due to the nonlinearity of the transfer characteristic. Using Fourier series it can be shown that the output waveform consists of the original input sine wave, plus sine waves at integer multiples of the input frequency. These harmonics represent nonlinearity in the device under test. Their amplitudes are related to the degree of nonlinearity.

### Distortion Measurement Procedure

All of the controls found on a traditional distortion analyzer are automated on the AA 5001. It is only necessary to set the INPUT RANGE and distortion range switches to AUTO RANGE, press THD+N and wait briefly for a reading.

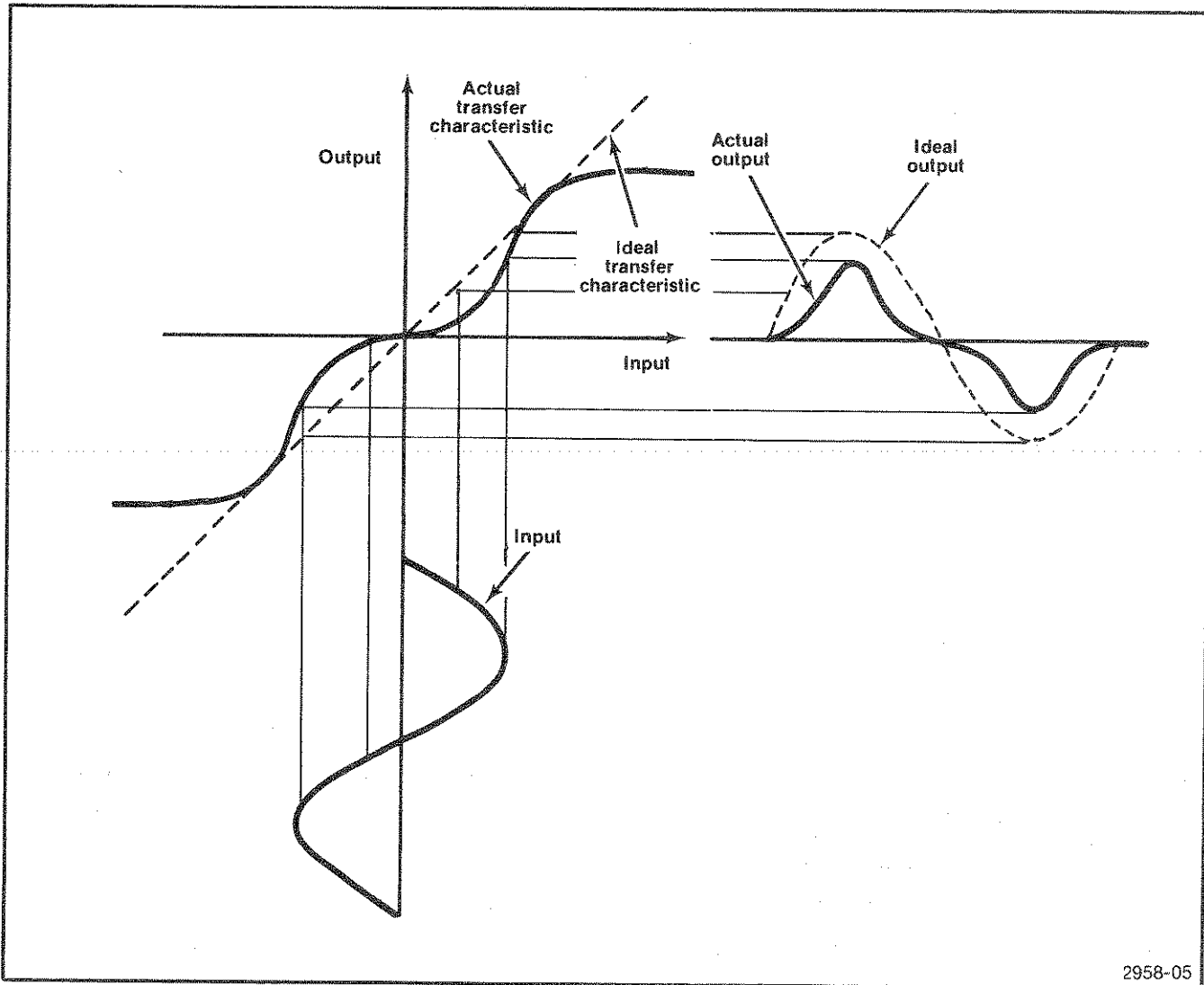

Fig. 2-6. THD test of transfer characteristics.

Minimum input signal amplitude for valid distortion measurements is 60 mV. To provide greater flexibility the instrument may be manually operated as described in the following paragraphs.

Adjustment of the input range control is the same as for level measurements. Setting the INPUT RANGE control to the correct scale ensures that the input is within the 10 to 12 dB range of the internal auto set-level circuitry. The range LED's must be extinguished to make readings to specified accuracy. The 200 uV, 2 mV and 20 mV ranges do not operate in the distortion function and a flashing Decrease Range LED indicates insufficient input signal level for distortion measurements.

To manually select a distortion range, press the THD+N button and the desired range button. Selection of AUTO RANGE causes the instrument to autorange the distortion readout. (With the AA 5001 in a remote state, the distortion range automatically goes to the AUTORANGE position, irrespective of the actual switch positions.) The remaining range pushbuttons cause the instrument to stay in these ranges without autoranging. This may reduce the measurement time slightly if the approximate reading is already known. This is useful in production line testing or in the testing of low distortion equipment. The dB display is effectively a single range; however, internal instrument operation is identical to AUTO RANGE.

When making distortion measurements, the RESPONSE button should normally be in the RMS position. Current distortion measurement standards require the use of rms reading instruments by specifying power summation of each of the components. The AVG response may be used when making comparisons with readings taken with older distortion analyzers. However, it may read up to 25% (2 dB) lower than rms response when noise is significant and even lower with high crest factor distortion signals (characteristic of crossover or hard-clipping non-linearities).

For frequencies below 20 kHz the residual wideband noise in the measurement may be reduced by activating the 80 kHz LO PASS filter. If hum (line related components) are interfering with the measurement, they may be reduced with the 400 Hz HI PASS filter. This filter should not be employed with fundamental frequencies below approximately 400 Hz because of additional error due to rolloff. For more information see text under Filters in this section of this manual.

## High Distortion Measurement Limitations

### NOTE

Care must be taken to ensure proper locking for input signals with 10% or greater noise or non-harmonic components, because the AA 5001 automatically tunes and nulls out the fundamental frequency prior to making a THD+N measurement.

In those applications which require higher THD+N measurements (for example, SINAD<sup>2</sup> testing) the internal circuitry will remain locked to noise levels of approximately 30%, after it is initially given a clean signal. To perform a SINAD test, the receiver under test is first given a high level modulated rf input. The AA 5001 will lock onto the audio signal at the demodulated output. The rf level feeding the receiver is then reduced until a -12 dB (25%) THD+N reading is obtained on the AA 5001 and becomes a measure of the receiver's sensitivity.

## IM Distortion Measurements

Another measurement of distortion investigates the interaction of two or more signals. Many tests have been devised to measure this interaction. Three common standards are SMPTE<sup>3</sup>, DIN<sup>4</sup>, and CCIF<sup>5</sup>. The AA 5001 is capable of automatically selecting and performing all three tests.

<sup>2</sup>Defined in Electronic Industries Association Standard No. RS 204A, July 1972, Electronic Industries Association, Engineering Department, 2001 Eye St. N.W., Washington, D.C. 20006.

<sup>3</sup>Society of Motion Picture and Television Engineers, Standard No. TH 22.51, 862 Scarsdale Avenue, Scarsdale, N.Y. 10583.

<sup>4</sup>Deutsches Institut für Normung e V, No. 45403 Blatt 3 and 4, January 1975, Beuth Verlag GmbH, Berlin 30 and Köln 1.

<sup>5</sup>International Telephone Consultative Committee.



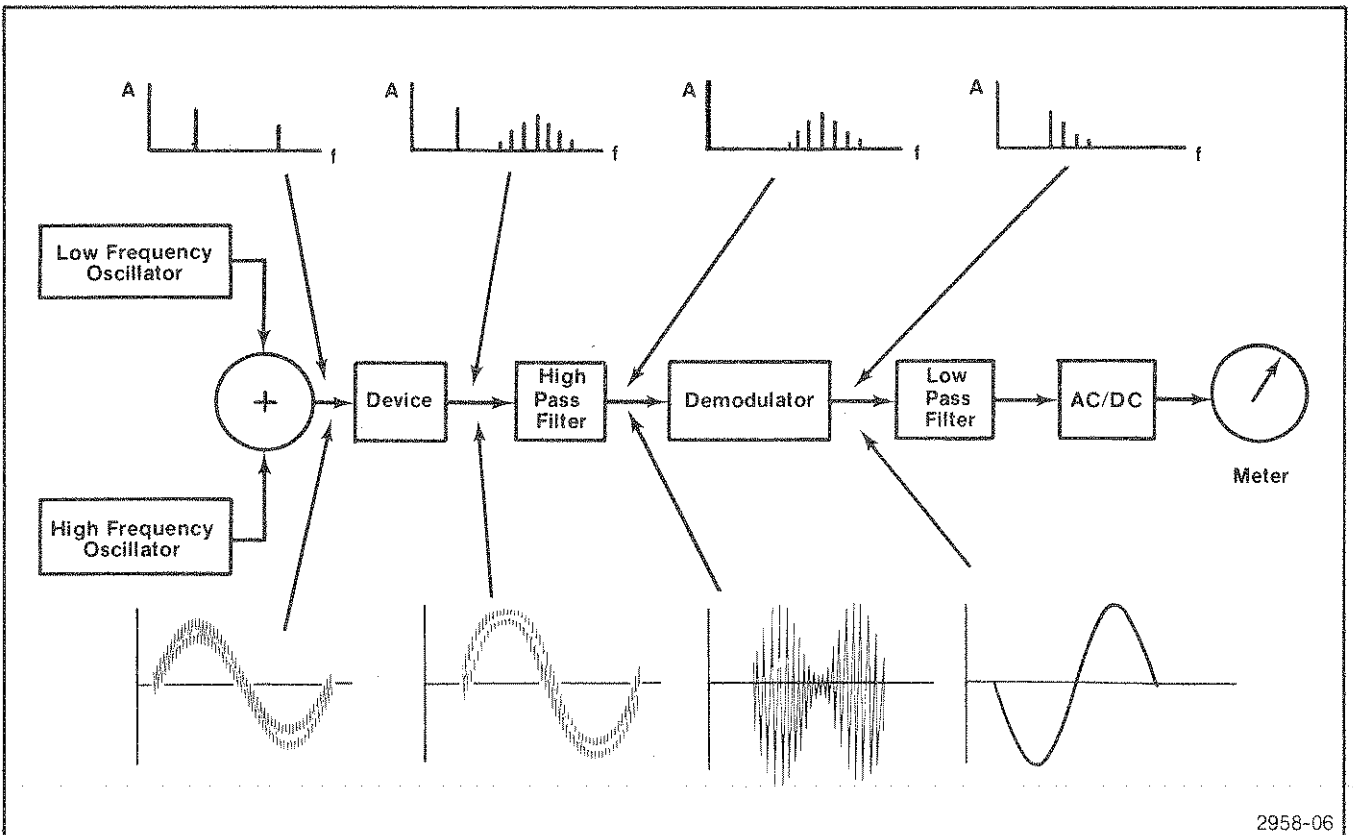

Fig. 2-7. Block diagram of basic IM analyzer.

To measure intermodulation distortion (IM), according to SMPTE and DIN standards, the device under test is excited with a low frequency and high frequency signal simultaneously (Fig. 2-7). The output signal is high-pass filtered to remove the low frequency component. The high frequency tone is then demodulated, as an AM radio signal. The demodulator output is low-pass filtered to remove the residual carrier (high frequency) components. The amplitude of the low frequency modulation is displayed as a percentage of the high frequency level.

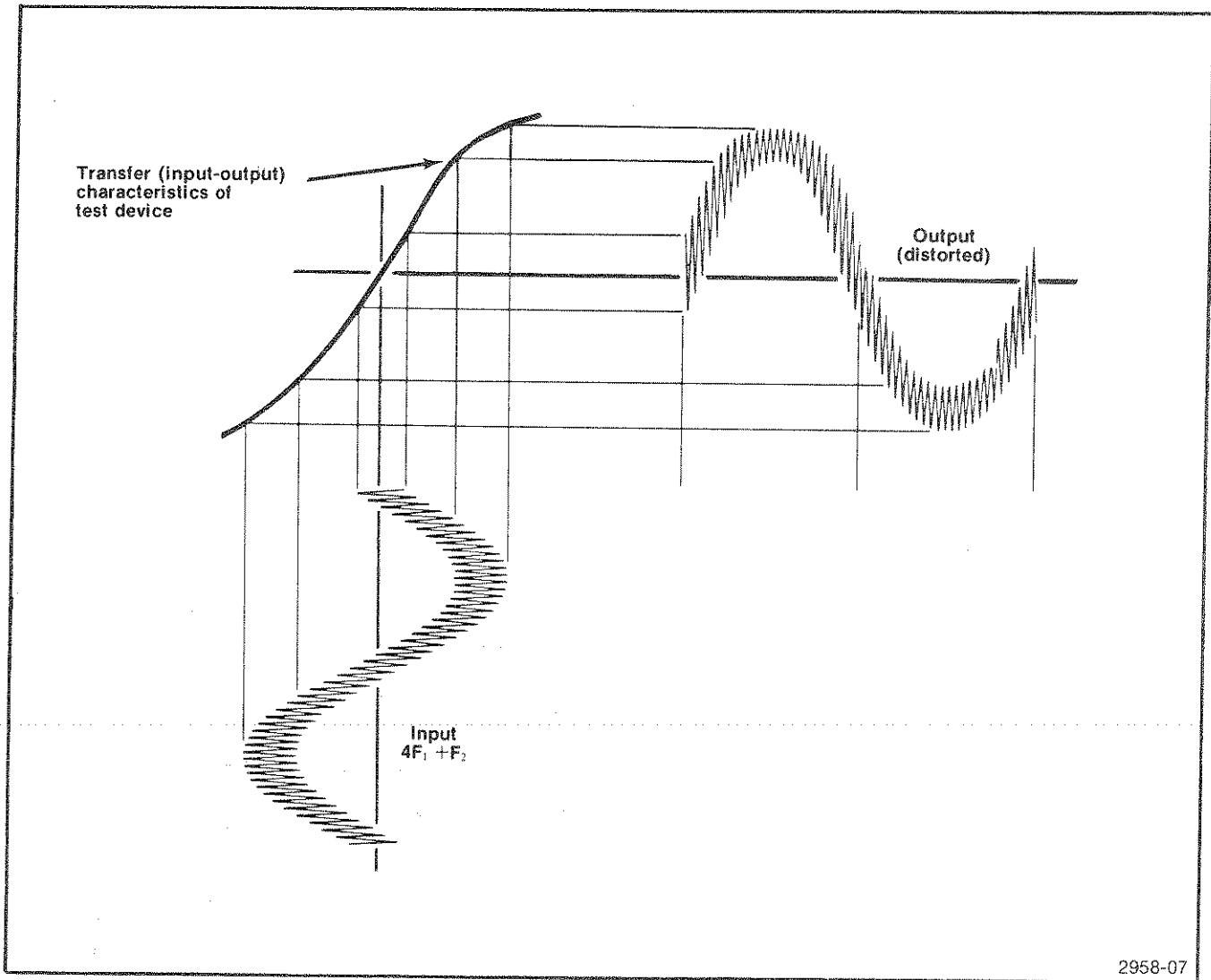

Fig. 2-8. IM test of transfer characteristics in time and frequency domain.

As shown in Fig. 2-8, when this composite signal is applied to the device, the output waveform is distorted. As the high frequency tone is moved along the transfer characteristic, by the low frequency tone, its amplitude changes. This results in low frequency amplitude modulation of the high frequency tone. This modulation is apparent in the frequency domain as sidebands around the high frequency tone. The power in these sidebands represents nonlinearity in the device under test.

The amplitude ratio of low to high frequencies should be between 4:1 and 1:1. The AA 5001 circuitry automatically adjusts calibration to compensate for the selected test signal ratio. Some additional range is provided in this circuitry to enable measurement of devices with nonflat frequency response.

SMPTE standard test frequencies are 60 Hz and 7 kHz. The DIN standard is virtually identical to the SMPTE standard except for the two frequencies used. They may be any pair of octave band center frequencies, with the upper at least eight times as high as the lower (250 Hz and 8 kHz are most common). The AA 5001 can accept a wide range of test frequencies as shown in the Specification section.

CCIF difference frequency distortion is measured with two high frequency sine waves driving the device under test. Both are of equal level and closely spaced in frequency. Nonlinearities in the device under test cause the sine waves to cross modulate. This creates new signals at various sum and difference frequencies from the inputs. For example, the commonly used 14 kHz and 15 kHz test frequencies produce 1 kHz, 13 kHz, 14 kHz, 15 kHz, 16 kHz, 28 kHz, etc. The user could measure each new component with a tunable filter such as a spectrum analyzer; however, this is usually limited to an 80 dB dynamic range and is very tedious. In many systems and especially those with asymmetric non-linearities, a good measure of this distortion may be obtained by investigating only the difference frequency (in this example 1 kHz). If only the low frequency component is measured, it is called a CCIF second order difference frequency distortion test.

To measure two tone difference frequency distortion the device is excited with two input signals as described above. The output of the device is low-pass filtered to remove the two test tones and extract the difference frequency product. The level of this component is expressed as a percentage of the high frequency signals. The AA 5001 CCIF difference frequency mode will accept any pair of input frequencies which are within limits as listed in the Specification section. The amplitudes of the two signals should be equal.

### **IM Distortion Measurement Procedure**

Intermodulation and THD testing are similar, using the AA 5001. After connecting the appropriate signal source to the device under test, set the INPUT RANGE as described in the THD section. Press the IMD FUNCTION button and select a distortion range. Selecting AUTO RANGE or dB provides automatic ranging. The AA 5001 accepts either a SMPTE, DIN, or a CCIF difference frequency test signal. Selection between the necessary analyzing circuits is accomplished automatically for IMD levels less than 20%, based upon the spectral content of the test tones. (There is a moveable jumper inside the AA 5001 to allow defeating the automatic test selection circuitry for special applications requiring IMD measurements in excess of 20%. Refer any jumper changes to qualified service personnel.)

The LO PASS and BAND PASS filters may be selected in the IM mode but will have little or no effect. The 400 Hz HI PASS and the WEIGHTING filters will cause erroneous readings because the IM components of interest generated by the tests fall between 50 Hz and 1 kHz. These filters, when activated in the IM mode may attenuate some of the frequency components being measured and should be avoided.

### **Filters**

The five buttons along the right edge of the instrument allow selection of four built-in frequency weighting filters plus an external filter, as desired. See Fig. 2-9 for response curves of the various

filters. The 400 Hz, and 80 kHz filters are both 3-pole (18 dB per octave rolloff) Butterworth alignment. The AUDIO BAND PASS filter follows CCIR Recommendation 468-2 for unweighted response. It is approximately two pole response below the lower 3 dB point of 22.4 Hz and three pole response above the upper 3 dB point of 22.4 kHz. They are placed in the measuring circuitry immediately before the average or rms detectors. These filters are functional in all modes of operation. They also affect the signal at the FUNCTION OUTPUT connector.

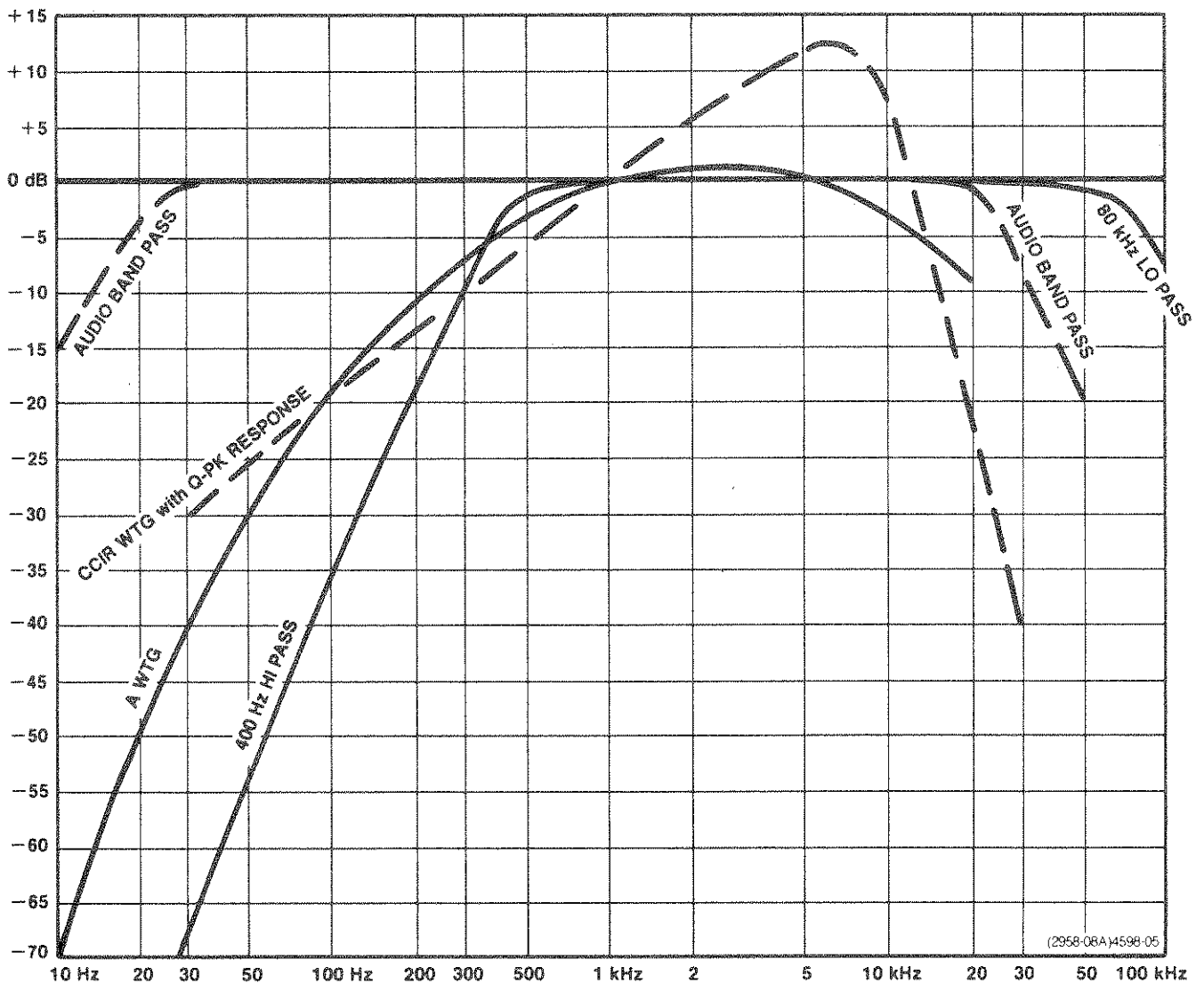

Fig. 2-9. Response curves for AA 5001 filters.

Check the position of all filter pushbuttons before making measurements, to prevent inaccurate results. Filtering takes place after all gain circuits. Therefore, it is possible to overload part of the instrument, when operating in the manual distortion ranges with a filter selected, even though the display is not overranged. This may be checked by releasing the filter pushbuttons and checking the display for overrange or by pressing the AUTO RANGE pushbutton.

The 400 Hz HI PASS filter is used to reduce the effects of hum on the measurement. Although the differential input and common mode rejection of the AA 5001 reduce the effects of ground loops, extremely bad measurement conditions may require use of this filter. The device under test may also generate an undesirable amount of hum, limiting the noise and distortion residuals obtainable. This filter may be used when measuring harmonic distortion of signals at about 400 Hz or greater, but should not be used when measuring levels at frequencies less than 1 kHz, nor when measuring intermodulation distortion.

Use of the 80 kHz LO PASS filter reduces the effects of wideband noise and permits measurement of lower THD+N for input signals up to 20 kHz. For 20 kHz inputs, it allows measurement of harmonics up to the fourth order. Do not use this filter if harmonic components above 80 kHz are of interest. When checking noise the 80 kHz filter may be used to reduce the measurement bandwidth. However, for most noise measurements, the AUDIO BANDPASS or WEIGHTING filters are recommended as they correlate better with the perceived noise level.

The AUDIO BAND PASS filter provides bandwidth limiting according to CCIR Recommendation 468-2 and DIN 45405. It is also useful for unweighted measurements on certain acoustic equipment. When the AUDIO BAND PASS filter is used, the 80 kHz filter is disabled.

The "A" weighting filter (standard instruments only) is used when measuring the subjective noisiness of audio equipment. It conforms to the noise measurement standards of the Institute of High Fidelity (IHF). The filter shape is within ANSI, DIN, and IEC<sup>6</sup> standards for class 1 sound level meters.

The CCIR weighting filter (option 02 instruments only) is also used when measuring the subjective noisiness of audio equipment, however it conforms to CCIR Recommendation 468-2 and DIN 45405 when used with the quasi-peak detector response. This filter may also be used with the rms detector, however the gain calibration is shifted for unity gain at 2.0 kHz instead of 1.0 kHz permitting noise measurements similar to those proposed by Dolby et al<sup>7</sup> on tape recording and playback systems.

Connections for an external filter are also provided. Press the EXT FILTER pushbutton. Connect the external filter between the FUNCTION OUTPUT and the AUXILIARY INPUT. One application for the external filter is selective measurement of individual harmonics or components of an input signal. This may be accomplished using a unity gain bandpass filter as an external filter<sup>8</sup> and adjusting the frequency to the harmonic desired.

<sup>6</sup>International Electrotechnical Commission, Publication 179, second edition, Precision Sound Level Meters, 1973, Central Office of EIC (sales department), 1, rue de Varembe, 1211 Geneva 20 Switzerland.

<sup>7</sup>Dolby et al, CCIR/ARM: A Practical Noise-Measurement Method, Journal of the Audio Engineering Society, Vol. 27, No. 3, March 1979, p. 149.

<sup>8</sup>International Radio Consultative Committee.

## Displays

The AA 5001 provides two display forms for manual measurements. The digital readout displays the selected function with units. Overrange indication blanks all digits and displays a 1 in the most significant digit slot.

For rapid nulling or peaking applications, the digital display is supplemented by an uncalibrated LED bar graph for an analog meter-like display. The bar graph responds logarithmically, with each segment representing approximately a 2.5 dB change in the selected function. Additionally, the intensity of the segments is modulated between steps permitting resolution of changes as small as 0.5 dB. The range of the bar graph is determined by the measurement range in use. When using this feature it may be desirable to select a manual range to prevent confusing displays caused by autoranging.

## Monitoring

The interface capabilities of the AA 5001 may aid considerably in the interpretation of measurements.

The INPUT MONITOR connector provides a fixed amplitude version (approximately equal to 1 V rms) of the input signal for input signals of 50 mV or greater. This allows display of the input signal on an oscilloscope, without constantly readjusting the oscilloscope sensitivity. At input levels below about 50 mV the INPUT MONITOR signal is approximately 26 dB (gain of approximately equal to 20) above the input signal level.

The FUNCTION OUTPUT is taken after the distortion measurement and high gain amplifier circuitry. It can be used for monitoring the signal read on the display. The signal at the FUNCTION OUTPUT connector is 2 V for a full scale reading on the display. In the level function this connector becomes an amplified version of the input signal. The gain from the input to this output is dependent on the INPUT RANGE switch, and is given in Table 2-1. When the AA 5001 is used as a constant gain differential amplifier the INPUT RANGE switch



must be set to a fixed range. In the distortion function this output can be displayed on an oscilloscope to view the distortion components. This output may also be used to drive a spectrum analyzer or selective voltmeter for examining the individual harmonics or modulation products. When an oscilloscope is used, the triggering signal is best taken from the sync output on the oscillator. If this is not possible (for example in tape recorder or Telco link testing) it should be obtained from the INPUT MONITOR connector on the AA 5001.

Table 2-1

Gains from INPUT terminals to FUNCTION OUTPUT connector for various settings of the INPUT RANGE control

| INPUT RANGE Setting | Gain to FUNCTION OUTPUT |
|---------------------|-------------------------|
| 200 V               | -40 dB                  |
| 60 V                | -30 dB                  |
| 20 V                | -20 dB                  |
| 6 V                 | -10 dB                  |
| 2 V                 | 0 dB                    |
| 600 mV              | +10 dB                  |
| 200 mV              | +20 dB                  |
| 20 mV               | +40 dB                  |
| 2 mV                | +60 dB                  |
| 200 $\mu$ V         | +80 dB                  |

One interesting use of the Function Output and Input Monitor signals is to investigate the non-linearities of the transfer function of a device under test with the THD+N mode. For this measurement the FUNCTION OUTPUT drives the vertical input of an oscilloscope while the INPUT MONITOR drives the horizontal. The resulting display is similar to Fig. 2-10, and represents the deviation from linearity of the transfer characteristic. In other words, it represents the

transfer characteristic after the best fit straight line is removed. This can be particularly useful in diagnosing sources of non-linearity such as clipping, crossover, etc. If the device under test has large amounts of phase shift at the test frequencies it may be necessary to introduce compensating phase shift into the horizontal channel. Since the FUNCTION OUTPUT is taken after the filters, they will affect the signal seen at this connector. The vertical scale is the deviation from the best fit line and is related to the distortion range and vertical sensitivity of the oscilloscope.

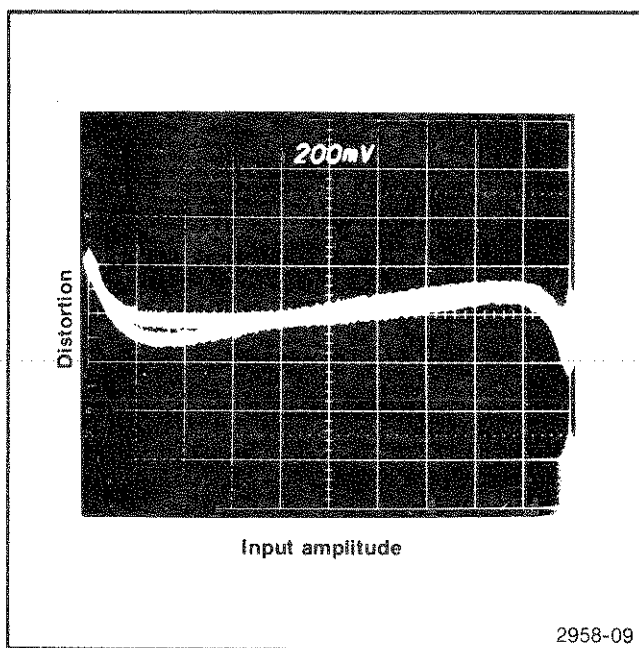

Fig. 2-10. Oscilloscope display of deviation from linearity.

**SECTION 3  
PROGRAMMING**

**Introduction**

This section of the manual provides information for programming the AA 5001 by remote control via the digital interface. In this manual the digital interface is called the IEEE-488 General Purpose Interface Bus (GPIB). The following information assumes the reader is knowledgeable in GPIB communications and has some exposure to programming controllers. Communication via the GPIB is specified and described in the <sup>1</sup>IEEE Standard 488-1978, Standard Digital Interface for Programmable Instrumentation<sup>1</sup>. TM 5000 instruments are designed to communicate with any GPIB-compatible controller that sends and receives ASCII messages (commands) over the GPIB. These commands program the instrument or request information from the instrument.

Commands for TM 5000 programmable instruments are designed for compatibility among instrument types. The same command is used in different instruments to control similar functions. In addition, commands are specified in mnemonics related to the functions they implement. For example, the command INIT initializes instrument settings to their power-up states.

<sup>1</sup>Published by the Institute of Electrical and Electronics Engineers, Inc., 345 East 47th Street, New York, NY, 10017

Instrument commands are presented in three formats:

**A front panel illustration** -- showing command relationships to front panel operation. See Fig. 3-1.

**Instrument Command List** -- A list divided into functional groups with brief descriptions.

**Detailed Command List** -- An alphabetical listing of commands with complete descriptions.

TM 5000 programmable instruments connect to the GPIB through a TM 5000 power module. Refer to the Operating Instructions section of this manual for information on installing the instrument in the power module. Also review this section to become familiar with front-panel and internally selectable instrument functions.

#### **GPIB Address and Terminator Setting**

The GPIB primary address for this instrument is set on the rear panel. The AA 5001 is shipped with the address set to decimal 28. The message terminators may also be selected. Message terminators are discussed in Messages and Communication Protocol (in this section). TM 5000 instruments are shipped with this terminator set to EOI ONLY. Refer qualified personnel to the Maintenance section of this manual for locations and setting information.

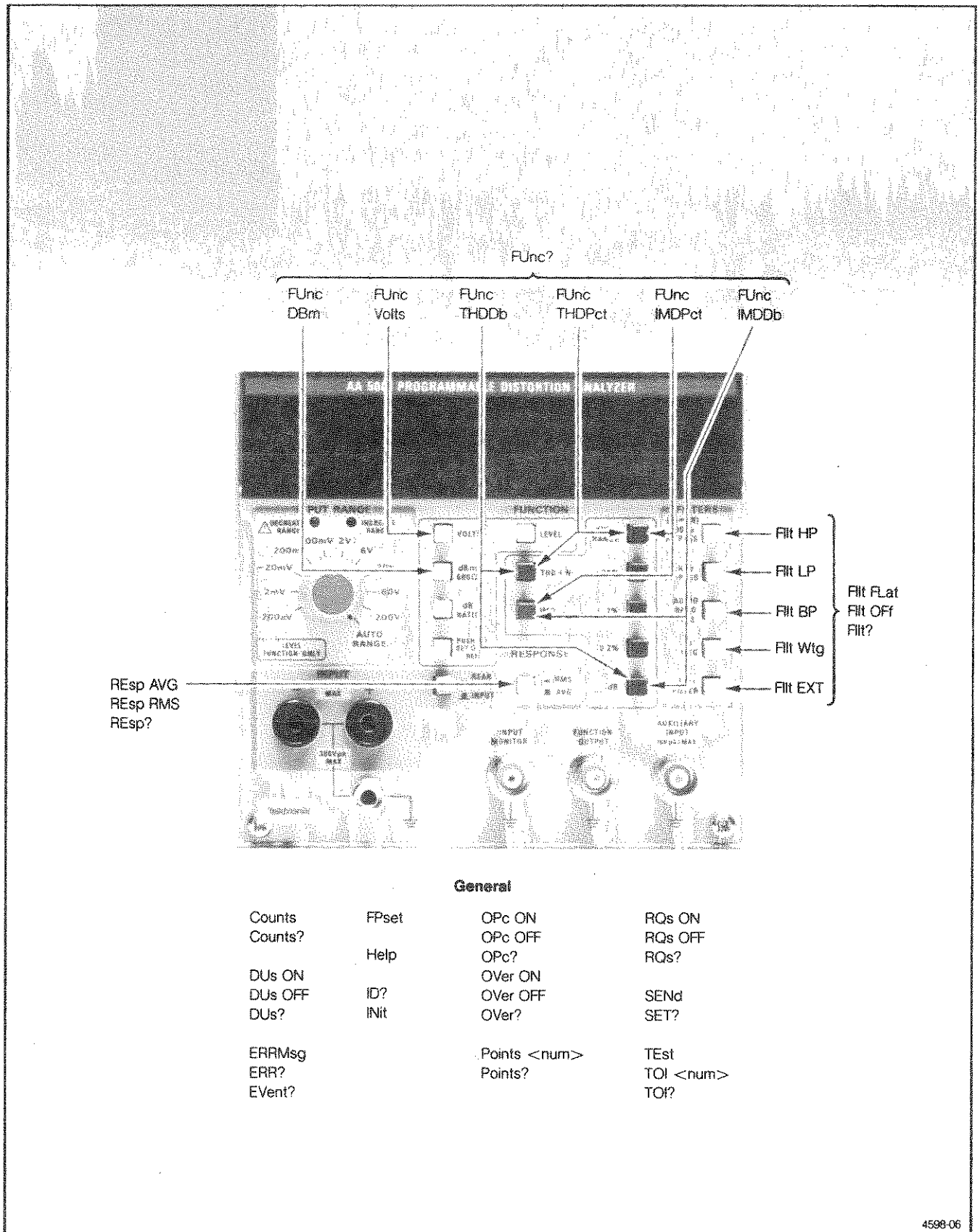

4598-06

Fig. 3-1. AA 5001 commands and relationships to front panel controls. See command lists for descriptions.

**COMMANDS**

The commands for the AA 5001 can be classified in three categories:

**Setting Commands** -- Control Instrument Settings

**Query-Output Commands** -- Ask For Data

**Operational Commands** -- Cause a particular action

The instrument responds to and executes all commands when in the remote state. In the local state setting and operational commands generate errors as the instrument is under front panel control. Only query-output commands are executed in this mode.

Each command begins with a header--a word that describes the function implemented. Many commands require an argument following the header--a word or number which specifies the desired state.

**NOTE**

Brackets [] indicate the enclosed item is optional, and carets <> indicate a defined element. Capitalized letters are the required characters; the lower case letters may also be used.

**Instrument Commands**

**Counts <num>** -- Sets the display counts window for the settling algorithm.

**Counts?** -- Returns the COUNTS setting.

**DUS [ON]** -- Delays the SEND command until settled.

**DUS OFF** -- Does not delay the SEND command until settled.

**DUS?** -- Returns DUS ON or DUS OFF.

**ERRMsg?** -- Same action as ERR? but includes a description string in the query response.

**ERRor?** -- Returns the error code for the most recent error reported by serial poll when RQS is ON or the highest priority event when RQS is OFF.

**Event?** -- Same action as ERR?

**[Filters] BPass** -- Enables bandpass filter.

**[Filters] EXternal** -- Enables external filter.

**[Filters] FLat** -- Disables all filters.

**[Filters] HPass** -- Enables high pass filter.

**[Filters] Lpass** -- Enables low pass filter.

**Filters OFF** -- Disables all filters.

**[Filters] Wtg** -- Enables weighting filter.

**Filters?** -- Returns the state of all programmable filters.

**FPset** -- Sets to front panel settings while under remote control.

**[Function] DBm** -- Selects level measurement in decibels relative to 0.775 volts.

**[Function] IMDDb** -- Selects intermodulation distortion measurement in decibels.

[Function] **IMDPct** -- Selects intermodulation distortion measurement in percent.

[Function] **THDDb** -- Selects total harmonic distortion measurement in decibels.

[Function] **THDPct** -- Selects total harmonic distortion measurement in percent.

[Function] **Volts** -- Selects level measurement in rms volts

**Function?** -- Returns the type of measurement selected.

**Help?** -- Returns a list of command headers.

**Identify?** -- Returns instrument identification and firmware version.

**Init** -- Returns instrument to default settings.

**OPc [ON]** -- Enables operation complete service request.

**OPc OFF** -- Disables operation complete service request.

**OPc?** -- Returns OPC ON or OPC OFF.

**Over [ON]** -- Enables reporting of display overrange, insufficient input level, excessive input level and unsettled service requests.

**Over OFF** -- Disables reporting of display overrange, insufficient input level, excessive input level and unsettled service requests.



**Over?** -- Returns OVER ON or OVER OFF.

**Points <num>** -- Sets the number of sample points for the settling algorithm.

**Points?** -- Returns the POINTS setting.

**[Response] AVG** -- Selects average response. (standard instrument only)

**[Response] AVE** -- Selects average response. (standard instrument only)

**[Response] RMS** -- Selects rms response.

**[Response] Qpk** -- Selects quasi-peak response. (option 2 only)

**Response?** -- Returns AVG (QPK for option 2) or RMS response.

**RQs [ON]** -- Enables generation of service requests.

**RQs OFF** -- Disables generation of service requests.

**RQs?** -- Returns RQS ON or RQS OFF.

**SEND** -- Returns a measurement.

**SETtings?** -- Returns all programmable settings.

**TEst?** -- Executes ROM test and returns 0 if test passes or 394 if test fails.

**Tolerance <num>** -- Sets the tolerance window for the settling algorithm in percent.

**Tolerance?** -- Returns the TOLERANCE setting.

## DETAILED COMMAND LIST

## NOTE

Brackets [] indicate the enclosed item is optional, and carets <> indicate a defined element. Capitalized letters are the required characters; the lower case letters may also be used.

**COUNTS****Type:**

Setting or query

**Setting Syntax:**

Counts <numeric>

**Arguments:**

Any floating point value from 0 to 2000

**Examples:**

Counts 20

Counts 4.5

Counts 1.2E+2

Counts 32.05E-2

**Query Syntax:**

Counts?

**Query Response:**

Counts <numeric>;

**Discussion:**

The COUNTS command sets the settling algorithm window in units of display counts. Refer to SETTLING ALGORITHM in this section.

The COUNTS query returns the COUNTS setting.  
The Power-up and INIT setting is COUNTS 2.0

**DUS (DELAY UNTIL SETTLED)**

**Type:**

Setting or query

**Setting Syntax:**

DUS [ON]

DUS OFF

**Query Syntax:**

DUS?

**Query Response:**

DUS ON; or DUS OFF

**Discussion:**

The DUS command tells the SEND command to delay sending a measurement until settling has occurred. Refer to SETTLING ALGORITHM and SEND in this section.

---

The Power-up and INIT setting is DUS ON.

**ERRMSG (ERROR MESSAGE)**

**Type:**

Query only

**Query Syntax:**

ERRMsg?

**Query Response:**

ERRMSG <numeric>,<string>;

**Example:**

ERRMSG 0,"NO STATUS";

**Discussion:**

The ERRMSG? query has the same action as the ERROR? query except that a brief description string is included in the query response.

**ERROR****Type:**

Query only

**Query Syntax:**

ERRor?

**Query Response:**

ERR &lt;numeric&gt;;

**Discussion:**

The ERROR? query is used to obtain information about the status of the instrument.

If RQS is ON, the ERROR? query returns an event code <number> describing why the RQS bit was set in the last Status Byte reported by the instrument. The event code is then reset to 0.

If RQS is OFF, the ERROR? query returns an event code <number> describing the highest priority condition currently pending in the instrument. This event code is then cleared and another ERROR? query will return the event code for the next highest priority condition pending.

**EVENT**

**Type:**

Query

**Query Syntax:**

EVent?

**Query Response:**

EVENT <numeric>;

**Discussion:**

The EVENT? query has the same action as the ERROR? query.

**FILTERS**

**Type:**

Setting or query

**Setting Syntax:**

[Filters] <argument>

[Filters] <argument>, ..., <argument>

**Arguments:**

BPass

EXternal

FLat

HPass

Lpass

OFF

Wtg

**Examples:**

Filt EXT

Filt HP

Filt OFF

BP

FLat

HP ON

HP OFF

Filt Lp,Wtg,EXT

**Query Syntax:**

Filters?

BPass?

FLat?

**Query Response:**

FILT BP,EXT,HP;

FILT FLAT;



**Discussion:**

Each individual command enables the specified filter. FLAT and OFF disables all the filters.

NOTE: "A" WEIGHTING is used on the standard instrument only.

"CCIR" WEIGHTING is used on option 2 only

Refer to the OPERATING INSTRUCTIONS section

For the setting command, multiple arguments separated by commas are allowed. The arguments are processed from left to right, that is the last argument prevails.

The FILTERS heading may be omitted for all arguments except OFF unless multiple arguments are used. If the FILTERS heading is omitted, the arguments ON or OFF may be optionally used. If not used, ON is assumed.

BP, LP, and WTG are all mutually exclusive.

The FILTERS? query returns a list of the filters that are enabled.

The INIT setting is FLAT.

**FPSET (FRONT PANEL SETTINGS)**

**Type:**

Operational

**Setting Syntax:**

FPset

**Discussion:**

The FPSET command sets the AA 5001 to the front panel settings even though it is under remote control.

This is useful for allowing manually set input level and distortion ranges, as these are otherwise autoranged when in the remote state.

Any other setting command made subsequently will defeat FPset.

**FUNCTION**

**Type:**

Setting or query

**Setting Syntax:**

[Function] <argument>

**Arguments:**

DBm

IMDDb

IMDPct

THDDb

THDPct

Volts

**Examples:**

FUnc IMPct

FUnc THDDb

THDPct

Volts

**Query Syntax:**

Function?<sup>1</sup>

**Query Response:**

DBM;

DBR;

IMDDB;

IMDPCT;

THDDB;

THDPCT;

VOLTS;

**Discussion:**

DBM selects input level measurement in decibels relative to 0.775 volts.

IMDDB selects intermodulation distortion measurements in decibels.

IMDPCT selects intermodulation distortion measurements in percent.

THDDB selects total harmonic distortion measurements in decibels.

THDPCT selects total harmonic distortion measurements in percent.

VOLTS selects level measurement in rms volts.

The use of the FUNCTION header is optional.

---

NOTE: DB RATIO is not programmable. References other than 0.775 volts (DBM), if needed, should be calculated by the controller.

The FUNCTION? query returns the type of measurement selected. The FUNCTION header is not returned.

The INIT setting is VOLTS.

**HELP**

**Type:**

Query

**Query Syntax:**

HElp?

**Query Response:**

HELP

AVE,AVG,BP,COUNTS,DBM,DUS,ERRMSG,ERR,EVENT,EXT,FILT,FLAT,  
FPSET,FUNC,HELP,HP,ID,IMDDB,IMDPCT,INIT,LP,OPC,OVER,POINTS,  
QPK,RESP,RMS,RQS,SEND,SET,TEST,THDDB,THDPCT,TOL,VOLTS,WTG;

**Discussion:**

The HELP? query returns a list of all valid command headers.

**IDENTIFY**

**Type:**

Query

**Query Syntax:**

Identify?

**Query Response:**

ID TEK/AA5001,V81.1,Fx.y; (standard instrument only)

ID TEK/AA5001,V81.1,Fx.y,"OPTION 2"; (option 2 only)

**Discussion:**

The IDENTIFY? query returns the above response where:

TEK/AA5001 - Identifies the instrument type.

V81.1 - Identifies the version of Tektronix Codes and  
Format Standard to which the instrument conforms.

Fx.y - Identifies the firmware version of the instrument,  
where x.y is a decimal number.

"OPTION 2" - Identifies options if any.

**INIT (INITIAL SETTINGS)**

**Type:**

Operational

**Setting Syntax:**

INit

**Discussion:**

The INIT command performs an initialization of the instrument's settings. The initialization settings for the AA 5001 are:

VOLTS

RMS

FLAT

DUS ON

POINTS 3

TOLERANCE 2.0

COUNTS 2.0

OPC OFF

OVER OFF

RQS ON

The INIT command does not generate a power-on SRQ nor does it put the instrument in LOCAL mode as power-on initialization does.

**OPC (OPERATION COMPLETE SERVICE REQUEST)****Type:**

Setting or Query

**Setting Syntax:**

OPc [ON]

OPc OFF

**Query Syntax:**

OPc?

**Query Response:**

OPC ON; or OPC OFF

**Discussion:**

The OPC command controls the asserting of SRQ when a measurement is completed. This command allows a controller to start a measurement, and then process some other task while waiting for an SRQ to inform it that measurement data is ready.

When OPC is ON and a measurement completes, SRQ is asserted and remains asserted until the status is read via a serial poll or until cleared by RQS OFF or a Device Clear. Operation Complete is indicated by a Status Byte of 66 or 82 and an ERROR query response of ERR 402.

Refer to STATUS AND ERROR REPORTING in this section.

The power-up and INIT setting is OPC OFF.



**OVER (OVERRANGE SERVICE REQUEST)**

**Type:**

Setting or query

**Setting Syntax:**

OVER [ON]

OVER OFF

**Query Syntax:**

OVER?

**Query Response:**

OVER ON; or OVER OFF;

**Discussion:**

The OVER command controls the asserting of SRQ for display overrange, insufficient level, excessive input level, and unsettled conditions.

These conditions are checked only when a measurement is attempted (see SEND command).

Refer to STATUS AND ERROR REPORTING in this section.

The power-up and INIT setting is OVER OFF.

## **POINTS**

### **Type:**

Setting or query

### **Setting Syntax:**

Points <numeric>

### **Arguments:**

Any Floating Point Value from 2 to 6

### **Query Syntax:**

Points?

### **Query Response:**

POINTS <numeric>;

### **Discussion:**

The POINTS command sets the number of sample points, 2 through 6, that must be within the settling algorithm's tolerance window for settling to occur. The numeric argument in the setting is rounded to the nearest integer. Refer to SETTLING ALGORITHM in this section.

The POINTS? query returns the POINTS setting.

The power-up and INIT setting is POINTS 3.

**RESPONSE****Type:**

Setting or query

**Setting Syntax:**

[REsponse] <argument>

**Arguments:**

|         |                            |
|---------|----------------------------|
| AVERage | (standard instrument only) |
| AVG     | (standard instrument only) |
| RMs     |                            |
| Qpk     | (option 2 only)            |

**Examples:**

REsp AVE  
 REsp RMs  
 RMs

**Query Syntax:**

REsponse?

**Query Response:**

RESP AVG; or RESP RMS; (standard instrument only)  
 RESP QPK; or RESP RMS; (option 2 only)

**Discussion:**

The RESPONSE command sets the AA 5001 for average (quasi-peak for option 2) or rms response.

The RESPONSE query returns the RESPONSE setting.

The RESPONSE header is optional.

The INIT setting is RESPONSE RMS.

**RQS (REQUEST FOR SERVICE)**

**Type:**

Setting or query

**Setting Syntax:**

RQs [ON]

RQs OFF

**Query Syntax:**

RQs?

**Query Response:**

RQS ON or OFF

**Discussion:**

The RQS command is a global control for assertion of SRQ by the AA5001.

When RQS is OFF the AA5001 will not assert SRQ under any circumstance. When RQS is ON the AA5001 is allowed to assert SRQ under appropriate circumstances; i.e., errors, operation complete, etc.

The ERROR? query can be used while RQS is OFF to see if any SRQ type conditions have occurred.

SRQ will be asserted for any previously unreported SRQ event when RQS is turned ON after being OFF.

The power-up and INIT setting is RQS ON.

**SEND****Type:**

Output

**Syntax:**

SEnD

**Discussion:**

The SEND command returns a measurement. Overrange is 1E+99. New measurements are available as the display updates at approximately three (3) reading/sec. Any display reading may be returned only once.

If the DUS is OFF the most recent display update is returned.

If DUS is ON, the measurement must be settled before it is returned. If settling does not occur within six (6) seconds, an average of the last two (2) seconds (6 display updates) is returned.

If the OVER is ON an unsettled SRQ is generated. Refer to SETTLING ALGORITHM, DUS, OVER, and TALKED WITH NOTHING TO SAY RESPONSE in this section.

**SETTINGS**

**Type:**

Query

**Query Syntax:**

SETtings?

**Query Response:**

<string>;

**Example:**

VOLTS;RESP RMS;FILT FLAT;DUS ON;POINTS 3;TOL 1.0;COUNTS  
1.0;OPC OFF;OVER OFF;RQS ON;

**Discussion:**

The SETTINGS? query returns the current settings of the instrument.

The SETTINGS? query response may then be used at a later time to reset the instrument back to those settings.

**TEST (ROM TEST)**

**Type:**

Query

**Setting Syntax:**

TEst?

**Output Response:**

TEST <numeric>;

**Discussion:**

The TEST? query causes execution of the ROM test and returns 0 if the test passes, or 394 if the test fails.

**TOLERANCE****Type:**

Setting or query

**Setting Syntax:**

Tolerance <numeric>

**Arguments:**

Any Floating Point Value from 0 to 100

**Examples:**

TO1 12

TO1 0.1E+2

TO1 1.5

**Query Syntax:**

Tolerance?

**Query Response:**

TOL <numeric>;

**Discussion:**

The TOLERANCE command sets the tolerance window in percent of the reading for the settling algorithm. Refer to SETTLING ALGORITHM in this section.

The TOLERANCE? query returns the TOLERANCE setting.

The power-up and INIT setting is TOLERANCE 2.0.



**SETTLING ALGORITHM**

This Algorithm delays a measurement from being sent until settling has occurred. The Settling Algorithm is enabled by using the DUS ON command. A settled AA 5001 measurement is obtained by using the SEND command to return a measurement with the Settling Algorithm previously enabled .

The AA 5001 is considered settled when a series of measurement points (display updates) are within a specified tolerance of each other. The tolerance window is plus or minus the sum of the values set by the TOLERANCE command (in percent of reading from 0 to 100) and the COUNTS command (in display counts from 0 to 2000). The POINTS command sets the number of measurement points (from 2 to 6) that must be within the tolerance window for settling to occur. In general, specifying as wide of a tolerance window and as few points as the accuracy of the measurement needed allows, will cause the instrument to return a valid measurement with a minimum of delay. The default settings will provide good results under most test conditions.

**THE DEFAULTS ARE:**

POINTS 3

TOLERANCE 2

COUNTS 2

When enabled, the SETTLING ALGORITHM is continually collecting measurement points and keeping track of the settling status. The algorithm is initialized at the time it is enabled (anytime DUS ON is received), or when any setting command is received. Initialization means any collected measurement points are dumped. At least two (2) points will be taken after receiving the SEND command before settled status can occur. The remaining points ,if needed, may have been collected before the SEND command was received, if the algorithm was enabled with sufficient time to collect these

points. This ensures that the algorithm includes the effects of any system changes that were made near the time the SEND command is received, but returns a measurement sooner if the AA 5001 remains settled. The measurement returned is the most recent measurement point taken at the time settling occurs.

If settling does not occur within approximately six (6) seconds after the SEND command is received, the AA 5001 returns the average of its last six (6) measurement points (approximately 2 seconds, in duration). This averaging allows usable measurements on signals containing low beat frequencies or noise. Additionally, if the OVER is ON, an unsettled SRQ is generated, alerting the controller that averaging has occurred.

#### **REMOTE LOCAL EXCEPTIONS**

If the LEVEL, THD+N, IMD, RESPONSE and any of the filter buttons are pressed, the AA 5001 returns to local from remote operation.

**MESSAGES AND COMMUNICATION PROTOCOL****Command Separator**

A message consists of one command or a series of commands, followed by a message terminator. Messages consisting of multiple commands must have the commands separated by semicolons. A semicolon at the end of a message is optional. For example, each line below is a message.

```
INIT
TEst;INit;RQs ON;DUs OFF;ID?;SET?
TEST;
```

**Message Terminator**

Messages may be terminated with EOI or the ASCII line feed (LF) character. Some controllers assert EOI concurrently with the last data byte. Others use only the LF character as a terminator. This instrument can be set to accept either terminator. With EOI ONLY selected as the terminator, the instrument interprets a data byte received with EOI asserted at the end of the input message; it also asserts EOI concurrently with the last byte of the output message. With the LF/EOI setting, the instrument interprets the LF character without EOI asserted (or any data byte received with EOI asserted) as the end of an input message. The AA 5001 transmits carriage return (CR) followed by line feed (the LF with EOI asserted) to terminate output messages. Refer service personnel to the Maintenance section of the manual for information on setting the message terminator. TM 5000 instruments are shipped with EOI ONLY selected.

**Formatting A Message**

Commands sent to the AA 5001 must have the proper format (syntax) to be understood. This format is flexible and many variations are acceptable. The following describes this format and the acceptable variations.

All commands must be encoded in upper and lower case ASCII. All data output is in upper case. See Fig. 3-2.

As previously discussed, a command consists of a header followed, if necessary, by arguments. A command with arguments must have a header delimiter which is the space character SP between the header and the argument. The space character , carriage return , and line feed are shown as subscripts in the following examples.

RQS<sub>SP</sub>ON

If extra formatting characters SP, CR, and LF (the LF cannot be used for format in the LF/EOI terminator mode) are added between the header delimiter and the argument, they are ignored by the instrument.

Example 1: RQS<sub>SP</sub>ON;

Example 2: RQS<sub>SP SP</sub>ON;

Example 3: RQS<sub>SP CR LF</sub>

<sub>SP SP</sub>ON

In general, these formatting characters are ignored after any delimiter and the beginning and end of a message.

<sub>SP</sub>RQS<sub>SP</sub>ON;<sub>CR LF</sub>  
<sub>SP</sub>DUS<sub>SP</sub>OFF

ASCII & IEEE 488 (GPIB) CODE CHART

| BITS |    |    |    | 0 0 |    | 0 0 1 |         | 0 1 0 |    | 0 1 1 |                 | 1 0 0 |    | 1 0 1 |            | 1 1 0 |     | 1 1 1 |       |   |     |         |
|------|----|----|----|-----|----|-------|---------|-------|----|-------|-----------------|-------|----|-------|------------|-------|-----|-------|-------|---|-----|---------|
| B7   | B6 | B5 | B4 | B3  | B2 | B1    | CONTROL |       |    |       | NUMBERS SYMBOLS |       |    |       | UPPER CASE |       |     |       | LOWER |   |     |         |
| 0    | 0  | 0  | 0  | 0   | 0  | 0     | 0       | NUL   | 20 | DLE   | 40              | SP    | 60 | 0     | 100        | @     | 120 | P     | 140   | \ | 160 | p       |
| 0    | 0  | 0  | 0  | 1   | 0  | 0     | 1       | SOH   | 21 | DC1   | 41              | !     | 61 | 1     | 101        | A     | 121 | Q     | 141   | a | 161 | q       |
| 0    | 0  | 0  | 1  | 0   | 0  | 0     | 2       | STX   | 22 | DC2   | 42              | "     | 62 | 2     | 102        | B     | 122 | R     | 142   | b | 162 | r       |
| 0    | 0  | 0  | 1  | 1   | 0  | 0     | 3       | ETX   | 23 | DC3   | 43              | #     | 63 | 3     | 103        | C     | 123 | S     | 143   | c | 163 | s       |
| 0    | 1  | 0  | 0  | 0   | 0  | 0     | 4       | EOT   | 24 | DC4   | 44              | \$    | 64 | 4     | 104        | D     | 124 | T     | 144   | d | 164 | t       |
| 0    | 1  | 0  | 0  | 1   | 0  | 0     | 5       | ENQ   | 25 | NAK   | 45              | %     | 65 | 5     | 105        | E     | 125 | U     | 145   | e | 165 | u       |
| 0    | 1  | 0  | 1  | 0   | 0  | 0     | 6       | ACK   | 26 | SYN   | 46              | &     | 66 | 6     | 106        | F     | 126 | V     | 146   | f | 166 | v       |
| 0    | 1  | 1  | 1  | 1   | 1  | 1     | 7       | BEL   | 27 | ETB   | 47              | '     | 67 | 7     | 107        | G     | 127 | W     | 147   | g | 167 | w       |
| 1    | 0  | 0  | 0  | 0   | 0  | 0     | 8       | BS    | 30 | CAN   | 50              | (     | 70 | 8     | 110        | H     | 130 | X     | 150   | h | 170 | x       |
| 1    | 0  | 0  | 0  | 1   | 0  | 0     | 9       | HT    | 31 | EM    | 51              | )     | 71 | 9     | 111        | I     | 131 | Y     | 151   | i | 171 | y       |
| 1    | 0  | 1  | 0  | 0   | 0  | 0     | 10      | LF    | 32 | SUB   | 52              | *     | 72 | :     | 112        | J     | 132 | Z     | 152   | j | 172 | z       |
| 1    | 0  | 1  | 0  | 1   | 0  | 0     | 11      | VT    | 33 | ESC   | 53              | +     | 73 | ;     | 113        | K     | 133 | [     | 153   | k | 173 | {       |
| 1    | 1  | 0  | 0  | 0   | 0  | 0     | 12      | FF    | 34 | FS    | 54              | ,     | 74 | <     | 114        | L     | 134 | \     | 154   | l | 174 |         |
| 1    | 1  | 0  | 0  | 1   | 0  | 0     | 13      | CR    | 35 | GS    | 55              | -     | 75 | =     | 115        | M     | 135 | ]     | 155   | m | 175 | }       |
| 1    | 1  | 1  | 0  | 0   | 0  | 0     | 14      | SO    | 36 | RS    | 56              | .     | 76 | >     | 116        | N     | 136 | ^     | 156   | n | 176 | ~       |
| 1    | 1  | 1  | 1  | 1   | 1  | 1     | 15      | SI    | 37 | US    | 57              | /     | 77 | ?     | 117        | O     | 137 | _     | 157   | o | 177 | 7 (DEL) |

ADDRESSED COMMANDS

UNIVERSAL COMMANDS

LISTEN ADDRESSES

TALK ADDRESSES

SECONDARY ADDRESSES OR COMMANDS

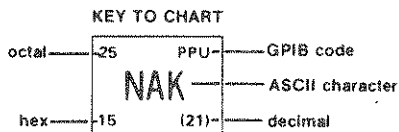

3391-13

Fig. 3-2. ASCII and IEEE 488 (GPIB) code chart.

In the command list, some letters are capitalized and others are lower case. The capitalized letters are the minimum necessary for command recognition. However, if additional letters are added they must be the same as shown in the header. For documentation of programs, the user may add alpha characters to the full header. Alpha characters may also be added to the query header, provided the question mark is at the end.

EV

EVe

EVen

EVent A?

Multiple arguments are separated by a comma; however, the instrument will also accept a space or spaces as a delimiter.

2,3

2<sub>SP</sub>3

2,SP3

#### NOTE

In the last example, the space is treated as a format character because it follows the comma (the argument delimiter).

#### Number Formats

The instrument accepts the following kinds of numbers for any of the numeric arguments.

- \* Signed or unsigned integers (including +0 and -0). Unsigned integers are interpreted as positive. Examples: +1, 2, -1, -10.
- \* Signed or unsigned decimal numbers. Unsigned decimal numbers are interpreted as positive. Examples: -3.2, +5.0, .2.

\* Floating point numbers expressed in scientific notation. Examples: +1.0E-2, 1.47E1, 1.E-2, 0.01E+0.

### **Rounding of Numeric Arguments**

The instrument rounds numeric arguments to the nearest unit of resolution and then checks for out-of-range conditions.

### **Message Protocol**

As the instrument receives a message it is stored in the input buffer, processed, and executed. Processing a message consists of decoding commands, detecting delimiters and checking syntax. For setting commands, the instrument stores the indicated changes in the pending settings buffer. If an error is detected during processing, the instrument asserts SRQ, ignores the remainder of the message, and resets the pending settings buffer. Resetting the pending settings buffer avoids undesirable states which could occur if some setting commands are executed while others in the same message are not.

Executing a message consists of performing the actions specified by its command(s). For setting commands, this involves updating the instrument settings and recording these updates in the current settings buffer. The setting commands are executed in groups -- that is, a series of setting commands is processed and recorded in the pending settings buffer before execution takes place. This allows the user to specify a new instrument state without considering if a particular sequence is valid. Execution of the settings occurs when the instrument processes the message terminator, a query-output command, or an operational command.

When the instrument processes a query-output command any preceding setting commands are executed to update the state of the instrument. The query-output command is then executed by retrieving the appropriate data and putting it in the output buffer. Then, processing and execution continue for the remainder of the message. When the instrument is made a talker the data are sent to the controller.

When the instrument processes an operational command, it executes any preceding setting commands before executing the operational command.

### Multiple Messages

A single message may be long enough to fill the input buffer. If so, a portion of the message is processed before the instrument accepts additional input. During command processing the instrument holds off additional data (by asserting NRFD) until space is available in the buffer.

When buffer space is available, the instrument accepts a second message before processing the first. However, additional messages are held off with NRFD until the first message is processed completely.

After the instrument executes a query-output command the response holds the output buffer until the instrument becomes a talker. If a new message is received before all of the output from the previous message is read the output buffer is cleared before executing the new message. This prevents the controller from getting unwanted data from old messages.

One other situation may cause the instrument to delete output. The execution of a long message might fill both the input and output buffers. When this occurs, the instrument cannot finish executing the message because it is waiting for the controller to read the data it has generated. But the controller cannot read the data because it is waiting to finish sending its message. Because the instruments input buffer is full and the remainder of the controllers message is held off by NRFD, the system is hung up. The controller and instrument are waiting for each other. When the instrument detects this condition, it generates an error, asserts SRQ and deletes the data in the output buffer. This allows the controller to transmit the rest of the message and informs the controller that the message was executed and the output was deleted.



**INSTRUMENT RESPONSE TO IEEE-488 INTERFACE MESSAGES**

Interface messages and their effects on the instruments interface functions are defined in IEEE Standard 488-1978. Abbreviations from the standard are used in this discussion, which describe the effects of interface messages on instrument operation.

Bus interface control messages are sent as low level commands through the use of WBYTE controller commands. For the following commands A = 32 plus the instrument address and B = 64 plus the instrument address.

|                                  |                    |
|----------------------------------|--------------------|
| Listen                           | WYBTE @ A:         |
| Unlisten                         | WYBTE @ 63:        |
| Talk                             | WYBTE @ B:         |
| Untalk                           | WYBTE @ 95:        |
| Untalk-unlisten                  | WYBTE @ 63, 95:    |
| Device clear (DCL)               | WYBTE @ 20:        |
| Selective device clear (SDC)     | WYBTE @ A, 4:      |
| Go to local (GTL)                | WYBTE @ A, 1:      |
| Remote with lockout              | WYBTE @ A, 17, 63: |
| Local lockout of all instruments | WYBTE @ 17:        |
| Group execute trigger (GET)      | WYBTE @ A, 8:      |

These commands are for the TEKTRONIX 4041 and 4050-Series controllers and representative for other controllers.

**UNL** -- Unlisten

**UNT** -- Untalk

When the AA 5001 receives the UNL command the listener function goes to the idle state (unaddressed). In the idle state, the AA 5001 does not accept instrument commands from the GPIB.

The talker function goes to the idle state when the AA 5001 receives the UNT command. In this state, the AA 5001 cannot output data via the GPIB.

The ADRS light is off when both the talker and listener functions are idle. The light is on if the instrument is either talk or listen addressed.

**IFC -- Interface Clear**

This uniline message has the same affect as both the UNT and UNL messages. The front panel ADRS light is off.

**DCL -- Device Clear**

The Device Clear message reinitializes communication between the instrument and controller. In response to DCL, the instrument clears any input and output messages and any unexpected settings in the pending settings buffer. Also cleared are any errors or events waiting to be reported, except the power-on events. When DCL is received by the AA 5001 an SRQ is unasserted if the SRQ line was asserted for any reason other than power-on.

**SDC -- Selected Device Clear**

This message performs the same function as DCL; however, only instruments that are listen addressed respond.

**GET -- Group Execute Trigger**

The AA 5001 recognizes the GET message. Upon receipt the AA 5001 issues an error.

**SPE -- Serial Poll Enable****SPD -- Serial Poll Disable**

The SPE message enables the AA 5001 to output serial poll status bytes when it is talk addressed. The SPD message switches the AA 5001 to sending data from the output buffer.

**MLA -- My Listen Address****MTA -- My Talk Address**

The primary listen and talk addresses are established by the AA 5001 GPIB address (internally set). When the AA 5001 is addressed to talk or listen, the front panel ADRS indicator illuminates.

**LLO -- Local Lockout**

In response to LLO, the AA 5001 goes to a lockout state -- from LOCS to LWLS or from REMS to RWLS.

**REN -- Remote Enable**

If REN is true, the instrument goes to a remote state (from LOCS to REMS or from LWLS to RWLS) when its listen address is received. When REN is false a transition from any state to LOCS. The AA 5001 stays in LOCS as long as REN is false.

A REN transition may occur after message processing has begun. In this case execution of the message being processed is not affected.

**GTL -- Go To Local**

Only instruments that are listen addressed respond to GTL. Remote-to-local transitions caused by GTL do not affect the execution of the message being processed when GTL is received.

**Talked With Nothing To Say Response**

The AA 5001 can be made a talker without having received a message that specifies the output. If the AA 5001 is talk addressed (receives MTA) without being specifically told what to say, it returns a measurement as if the SEND command was received. Refer to the SEND command in this section.

**Remote-Local Operation**

The preceding discussion described the state transitions caused by GTL and REN. The LEVEL, THD+N, IMD RESPONSE or FILTERS pushbuttons cause a transition from REMS to LOCS by asserting a message called return-to-local (rtl). This transition may occur during message execution. In contrast to GTL and REN transitions, a transition initiated by rtl does affect message execution. The instrument generates an error if there are any unexecuted setting or operational commands.

The instrument maintains a record of its settings in the current settings buffer. New settings from the front panel or the controller update these settings. In addition, the front panel is updated to reflect setting changes due to commands. The REMOTE indicator is illuminated when the instrument is in REMS or RWLS.

#### **Local State (LOCS)**

In LOCS, instrument settings are controlled by the operator via front panel pushbuttons. When in LOCS, only bus commands that do not change instrument settings are executed (query-output commands). All other bus commands (setting and operational) generate an error as their functions are under front panel control.

#### **Local With Lockout State (LWLS)**

The instrument operates the same as in LOCS, except rtl does not inhibit a transition to remote.

---

#### **Remote State (REMS)**

In this state, the instrument executes all instrument commands. For commands having front panel indicators, the front panel is updated when the commands are executed.

Both the input range and distortion range are forced to auto-range except when the "FPset" command is used (see FPset).

#### **Remote With Lockout State (RWLS)**

Instrument operation is identical to REMS operation except the rtl message is ignored.

### STATUS AND ERROR REPORTING

Through the Service Request function (defined in the IEEE-488 Standard), the instrument alerts the controller that it needs service. This service request is also a means of indicating that an event (a change in status or an error) has occurred. To service a request the controller performs a Serial Poll. In response the instrument returns a Status Byte (STB) which indicates if it requested service. The STB also provides a limited amount of information about the request. The format of information encoded in the STB is given in Fig. 3-3. When data bit 8 is set, the STB conveys Device Status information indicated by bits 1 through 4.

| STATUS BYTE (Example)           | 8   | 7  | 6  | 5  | 4 | 3 | 2 | 1 | Bit 5        | Bit 5    |
|---------------------------------|-----|----|----|----|---|---|---|---|--------------|----------|
| DECIMAL WEIGHT                  | 128 | 64 | 32 | 16 | 8 | 4 | 2 | 1 | not asserted | asserted |
| <b>Normal Conditions:</b>       |     |    |    |    |   |   |   |   |              |          |
| Power-up                        | 0   | 1  | 0  | x  | 0 | 0 | 0 | 1 | 65           | 81       |
| Operation complete              | 0   | 1  | 0  | x  | 0 | 0 | 1 | 0 | 66           | 82       |
| Display overrange               | 0   | 1  | 0  | x  | 0 | 1 | 0 | 0 | 68           | 84       |
| No events                       | 1   | 0  | 0  | x  | 0 | 0 | 0 | 0 | 128          | 144      |
| <b>Device Dependent Events:</b> |     |    |    |    |   |   |   |   |              |          |
| insufficient input level        | 1   | 1  | 0  | x  | 0 | 0 | 0 | 1 | 193          | 209      |
| Excessive input level           | 1   | 1  | 0  | x  | 0 | 0 | 1 | 1 | 195          | 211      |
| Unsettled                       | 1   | 1  | 0  | x  | 0 | 1 | 0 | 0 | 196          | 212      |
| <b>Abnormal Conditions:</b>     |     |    |    |    |   |   |   |   |              |          |
| Command errors                  | 0   | 1  | 1  | x  | 0 | 0 | 0 | 1 | 97           | 113      |
| Execution errors                | 0   | 1  | 1  | x  | 0 | 0 | 1 | 0 | 98           | 114      |
| Internal errors                 | 0   | 1  | 1  | x  | 0 | 0 | 1 | 1 | 99           | 115      |

4598-07

Fig. 3-3. Definition of status bytes.

As the STB conveys limited information about an event, the events are divided into classes; the Status Byte reports the class of events. The classes of events are listed as follows:

**COMMAND ERROR** Indicates the instrument received a command which it cannot understand.

**EXECUTION ERROR** Indicates that the instrument received a command that it cannot execute. This is caused by arguments out of range or settings that conflict.

**INTERNAL ERROR** Indicates that the instrument has detected a hardware condition or firmware problem that prevents operation.

**SYSTEM EVENTS** Events that are common to instruments in a system (e.g., Power on, User Request, etc.).

**INTERNAL WARNINGS** The instrument has detected a problem. The instrument remains operational but the problem should be corrected.

**DEVICE STATUS** Device dependent events.

The instrument can provide additional information about many of the events, particularly the errors reported in the Event Query. After determining that the instrument requested service (by examining the STB) the controller may request additional information by sending an event query (EVENT). In response, the instrument returns a code which defines the event. These codes are described in Table 3-1.

**Table 3-1  
ERROR QUERY AND STATUS INFORMATION**

| Event   | Bus response<br>to ERR? | Response to<br>serial poll |
|---|-------------------------|----------------------------|
| <b>Abnormal Conditions</b>                      |                         |                            |
| Command Errors                                  |                         |                            |
| Command header error                            | 101                     | 97 or 113                  |
| Header delimiter error                          | 102                     | 97 or 113                  |
| Command argument error                          | 103                     | 97 or 113                  |
| Argument delimiter error                        | 104                     | 97 or 113                  |
| Missing argument                                | 106                     | 97 or 113                  |
| Invalid message unit delimiter                  | 107                     | 97 or 113                  |
| Execution Errors                                |                         |                            |
| Command not executable in local mode            | 201                     | 98 or 114                  |
| Returned to local, new pending<br>settings lost | 202                     | 98 or 114                  |
| I/O buffers full, output dumped                 | 203                     | 98 or 114                  |
| Argument out of range                           | 205                     | 98 or 114                  |
| Group execute trigger ignored                   | 206                     | 98 or 114                  |
| Internal Errors                                 |                         |                            |
| Interrupt fault                                 | 301                     | 99 or 115                  |
| System error                                    | 302                     | 99 or 115                  |
| Math pack error                                 | 303                     | 99 or 115                  |
| <b>Normal Conditions</b>                        |                         |                            |
| System Events                                   |                         |                            |
| Power-up  | 401                     | 65 or 81                   |
| Operation complete                              | 402                     | 66 or 82                   |
| Execution Warning                               |                         |                            |
| Display overrange                               | 601                     | 68 or 84                   |
| Device Dependent Events                         |                         |                            |
| Insufficient input level                        | 701                     | 193 or 209                 |
| Excessive input level                           | 703                     | 195 or 211                 |
| Unsettled                                       | 704                     | 196 or 212                 |
| No Errors or Events                             |                         |                            |
| With data not ready                             | 0                       | 0 or 16                    |
| With data ready                                 |                         | 128 or 144                 |
|   |                         | 132 or 148                 |

If the message processor is busy, the instrument returns the higher decimal number.

To report more than one event, the instrument continues to assert SRQ until all events are reported. Each event is cleared when reported via Serial Poll. The Device Clear (DCL) interface message clears all events except Power On.

Some commands control reporting of certain individual events and disable all service requests. For example, the Request for Service command (RQS) controls the reporting of events with SRQ. The Operation Complete Service Request (OPC) asserts SRQ where a valid reading is available. The Overrange Service Request (OVER) command asserts SRQ when the for overrange, increase range or decrease range conditions.

RQS OFF inhibits all SRQs. In this mode the EVENT? query allows the controller to find out about events without performing a Serial Poll. With RQS OFF, the controller may send the EVENT? query at any time and the instrument returns an event waiting to be reported. The controller can clear all events by sending the EVENT? query until a zero (0) code is returned, or clear all events except power-on through the DCL interface message.

With RQS OFF the controller may perform a Serial Poll, but the Status Byte only contains Device Dependent Status information. With RQS ON, the STB contains the class of the event and a subsequent EVENT? query returns additional information about the previous event reported in the STB.

### **Power-up Conditions**

During power up, the AA 5001 microprocessor performs a diagnostic routine (self test) to check the functionality of the ROM and RAM. If no error is found, the instrument enters the Local State (LOCS) with the default settings as listed in Table 3-3. The SRQ line on the GPIB is asserted. If an internal error is found, an error code is displayed using the front-panel annunciators. See Table 6-3 in the Maintenance Section for front panel error displays.



The instrument goes to the front panel settings and the following at power-up:

**Table 3-3**  
**POWER-UP SETTINGS**

| Header | Argument |
|--------|----------|
| COUNTS | 2.0      |
| DUS    | ON       |
| OPC    | OFF      |
| POINTS | 3        |
| RQS    | ON       |
| TOL    | 2.0      |
| OVER   | OFF      |

#### **The POLL Statement and Clearing SRQ**

The POLL statement causes the BASIC interpreter in the 4050 series controllers to serially poll each peripheral device on the General Purpose Interface Bus (GPIB) to determine the device requesting service. When the device is found, the device sends its status byte to the BASIC interpreter over the GPIB.

The POLL statement is normally executed in response to a service request from a peripheral device on the GPIB. Two numeric variables are specified as parameters in the POLL statement followed by a series of I/O addresses. The BASIC interpreter polls the first I/O address in the list, the second I/O address, the third, and so on, until the device requesting service is found. Program execution is halted, if the I/O address of the device requesting service is not in the list.

The AA 5001 asserts SRQ during power up or power down. The power up SRQ must be cleared before continuing.

POLL A,B;22

This statement shows a method of clearing the service request. Two numeric variables A and B are specified. Following the variables is the semicolon delimiter and the instrument address or the alpha character defined as the instruments primary address. After the device requesting service is found the devices position in the list is assigned to the first variable. The status word from this device is assigned to the second variable.

**Information Available**

Additional assistance in developing specific application oriented software is available in the following Tektronix manuals.

- (1) 070-3985-00--GPIB Programming Guide. This manual is specifically written for applications of this instrument in IEEE-488 systems. It contains programming instructions, tips and some specific example programs.
- (2) 070-3917-00--4041 System Controller Programmer's Reference manual.
- (3) 070-2270-00--4051 GPIB Hardware Support Manual. This manual gives an indepth discussion of IEEE-488 bus operation, explanations of bus timing details and early bus interface circuitry.
- (4) 070-2058-01--Programming In BASIC.
- (5) 070-2059-01--Graphic Programming In BASIC.
- (6) 070-2380-01--4907 File Manager Operatos manual.
- (7) 070-2128-00--4924 Users manual
- (8) 070-1940-01--4050 Series Graphic System Operators manual
- (9) 070-2056-01--4050 Series Graphic System Reference manual
- (10) 070-3918-00--4041 Operators manual
- (11) 061-2546-00--4041 Programming Reference manual

**PROGRAMMING EXAMPLES ARE GIVEN**

**ON THE FOLLOWING PAGES**

```

100 ! *****
110 ! ***** TALKER/LISTENER PROGRAM FOR 4052A / AA 5001 *****
120 ! *****
130 !
140 ! Oct 4, 1983
150 !
160 ! PURPOSE:
170 ! Supports operator interaction with the AA 5001 over the GPIB.
180 ! The operator may enter AA 5001 commands and observe the
190 ! results. Service requests, such as for an incorrect command,
200 ! are handled.
210 !
220 ! REQUIRED EQUIPMENT:
230 ! 4052A Controller
240 ! AA 5001 Programmable Distortion Analyzer.
250 !
260 ! VARIABLES USED:
270 !
280 ! Aa_pri_addr -- AA 5001 primary address. Assigned value of 28.
290 ! Change if instrument set to other address.
300 !
310 ! Spoll_stat -- Status returned by serial poll from first
320 ! instrument requesting service.
330 !
340 ! Addr_list_indx -- Address list index returned by serial poll.
350 !
360 ! Addr_list -- Array of addresses found by CONFIG routine.
370 !
380 ! Config_code -- Flag returned by config routine.
390 !
400 ! Aa_command$ -- Commands entered by the operator and directed
410 ! to the AA 5001.
420 !
430 ! Aa_response$ -- Response from the AA 5001 to Ss_command$
440 ! (null if no output command contained in Aa_command$).
450 !
460 ! ROUTINE CALLED:
470 ! Serial poll subroutine handles instrument service requests
480 ! from all instruments on the bus.
490 !
500 ! POSSIBLE ERRORS:
510 ! AA 5001 primary address is set different than the number
520 ! assigned to Aa_pri_addr.
530 !
540 INIT
550 DIM Aa_response$(300),Aa_command$(100),Addr_list(15)
560 Aa_pri_addr=28
570 !
580 CALL "config",Config_code,Addr_list
590 IF Config_code THEN
600 PRINT "Configuration routine failed due to problem on GPIB."
610 STOP
620 END IF
630 !
640 ON SRQ THEN 790
650 !
660 PRINT "AA 5001 TALKER/LISTENER PROGRAM"
670 !
680 PRINT "Enter command message: ";
690 INPUT Aa_command$
700 PRINT @Aa_pri_addr:Aa_command$
710 INPUT @Aa_pri_addr:Aa_response$
720 PRINT Aa_response$

```

Fig. 3-4. AA 5001 Talker Listener program (4052A).

```

730 GO TO 680
740 END
750 !
760 ! Serial poll routine
770 LOCAL Aa_report$
780 DIM Aa_report$(80)
790 POLL Addr_list_indx,Spoll_stat;Addr_list
800 IF Addr_list(Addr_list_indx)=Aa_pri_addr THEN
810   PRINT @Aa_pri_addr;"id?;errms?"
820   INPUT @Aa_pri_addr;Aa_report$
830   PRINT "ADDRESS=";Addr_list(Addr_list_indx),"STATUS=";Spoll_stat
840   PRINT Aa_report$
850 END IF
860 RETURN ! From service request subroutine

```

Fig. 3-4 cont. AA 5001 Talker Listener program (4052A).

```

100 ! *****
110 ! ***** TALKER/LISTENER PROGRAM FOR 4041 / AA 5001 *****
120 ! *****
130 !
140 ! October 4, 1983
150 !
160 ! PURPOSE:
170 ! Supports operator interaction with the AA 5001 over the GPIB.
180 ! The operator may enter AA 5001 commands and observe the results.
190 ! Service requests, such as for an incorrect command, are handled.
200 !
210 ! REQUIRED EQUIPMENT:
220 ! 4041 Controller (V2.0)
230 ! AA 5001 Programmable Distortion Analyzer.
240 !
250 ! VARIABLES USED:
260 !
270 ! Aa_pb -- AA 5001 primary address. Assigned value of 28. Change if
280 ! instrument set to other address.
290 !
300 ! Aa_port -- Port where AA 5001 connected. Assigned value of 0.
310 ! Change if instrument is connected to GPIB1 instead of GPIB0.
320 !
330 ! Aastrem$ -- Stream specification for AA 5001.
340 !
350 ! Spollsta -- Status returned by first instrument found requesting service.
360 !
370 ! Spolladd -- Address of first instrument found requesting service.
380 !
390 ! Command$ -- Commands entered by the operator and directed to the AA 5001.
400 !
410 ! Respons$ -- Response of the AA 5001 to command$ (null if no output
420 ! command contained in command$).
430 !
440 ! LOGICAL UNIT USED:
450 ! 100: Assised to AA 5001 stream spec.
460 !
470 ! ROUTINE CALLED:
480 ! Pollbus Handles request for service from any instrument on the
490 ! bus selected by the AA 5001 stream spec.
500 !

```

Fig. 3-5. AA 5001 Talker Listener program (4041).

```

510 ! POSSIBLE ERRORS:
520 ! aa_pa or aa_port variables do not match the AA 5001 primary address or
530 ! port where AA 5001 is connected, respectively.
540 !
550 ! Dim respons$ to 300,command$ to 100,astrem$ to 20
560 ! Integer aa_pa,spollsta,spolladd,aa_port
570 ! As_pa=28
580 ! As_port=0
590 !
600 ! Astrem$="spib"&str$(aa_port)&"(pri="&str$(aa_pa)&")!"
610 ! Open #100:astrem$
620 ! Select astrem$
630 ! On sra then call pollbus
640 ! Enable sra
650 !
660 Tlk_lisn:      input prompt "Enter command message: ";command$
670 ! Input #100 prompt command$;respons$
680 ! Print respons$ ! AA 5001 returns blank line if not queried in command$
690 ! Goto tkl_lisn
700 ! End ! Main
800 Sub pollbus local report$
810 ! PURPOSE:
820 ! Handles spib service requests. Polls all primary addresses until
830 ! source of sra is found. If sra from instrument at AA 5001 primary
840 ! address, routine queries id and error message.
850 !
860 ! LOCAL VARIABLE:
870 ! Report$: Id and event report from instrument at aa_pa if it has sra.
880 !
890 ! Dim report$ to 80
900 ! Poll spollsta,spolladd
910 ! If spolladd=aa_pa then input #100 prompt "id?;errmss?";report$
920 ! Print report$,"STATUS=";spollsta,"ADDRESS=";spolladd,"PORT=";val(astrem$)
930 ! Resume
940 ! End ! Sub pollbus

```

Fig. 3-5 cont. AA 5001 Talker Listener program (4041).

```

100 ! *****
110 ! ***** TOTAL HARMONIC DISTORTION VERSUS FREQUENCY *****
120 ! *****
130 !
140 ! For 4050A Series:July 22, 1983      Revised: September 28, 1983
150 !
160 ! Copyright (c) 1983 Tektronix, Inc. All rights reserved. This
170 ! software is provided on an "as is" basis without warranty of
180 ! any kind. It is not supported.
190 !
200 ! This program may be reproduced without prior permission, in
210 ! whole or in part, by the original purchaser. Copies must
220 ! include the above copyright and warranty notice.
230 !
240 ! PURPOSE:
250 ! Records the total harmonic distortion of a system to a leveled
260 ! input signal which is swept from 10 Hz-100 KHz in logarithmic
270 ! fashion. The total number of points is 21. The results are then
280 ! plotted on the 4050A Series screen.
290 !

```

Fig. 3-6. AA 5001 program example (4050A series).

```

300 ! REQUIRED EQUIPMENT:
310 ! AA 5001 Programmable Distortion Analyzer.
320 ! SG 5010 Programmable 160 KHz Oscillator.
330 ! 4050A Series Controller
340 !
350 ! PROGRAM SEGMENT VARIABLES:
360 ! a$prim      AA 5001 primary address. Factory set to 28.
370 ! s$prim      SG 5010 primary address. Factory set to 25.
380 ! nsteps      number of frequency steps.
390 ! freqaray    array of calculated frequencies.
400 ! thdaray     array of measured total harmonic distortion.
410 ! freqstrt    sweep starting frequency.
420 ! freqstop    sweep stop frequency.
430 ! _toleran    tolerance for Delay Until Settled algorithm.
440 ! counts      number of counts for DUS algorithm in AA 5001.
450 ! _points     number of readings to be within tolerance and
460 !             counts.
470 ! amplit      output amplitude of SG 5010.
480 !
490 ! OPERATING INSTRUCTIONS:
500 ! Connect output of SG 5010 to input of Device Under Test.
510 ! Connect output of IUT to input of AA 5001. Address of AA 5001
520 ! must be set to 28 and address of SG 5010 must be set to 25. If
530 ! addresses are different from these factory set addresses, then
540 ! variables a$prim ( AA 5001 primary address ) and s$prim ( SG 501
550 ! primary address ) must be changed accordingly.
560 !
570 ! ERRORS:
580 ! AA 5001 and SG 5010 addresses must be set to 28 and 25
590 ! respectively or program assignments of variables a$prim
600 ! and s$prim changed in program.
610 !
620 ! INSTRUMENT CONTROL:
630 ! Polls instruments on assigned addresses (AA 5001 and SG 5010).
640 !
650 ! *****
660 ! Begin main program segment
670 INIT
680 PAGE
690 A$prim=28
700 S$prim=25
710 Nsteps=21
720 DIM Freqaray (Nsteps),Thdaray (Nsteps)
730 Freqstrt=10
740 Freqstop=100000
750 _toleran=0.1
760 Counts=1
770 _points=6
780 Amplit=1
790 Title$="THD VERSUS FREQUENCY"
800 Xtitle$="Frequency in Hertz"
810 Ytitle$="THD in Percent"
820 ON SRQ THEN 1950
830 !
840 ! Get frequency values for sweep.
850 CALL Sweeplos(Freqstrt,Freqstop,Nsteps,Freqaray)
860 !
870 ! Initialize Instruments
880 WBYTE @A$prim+32,S$prim+32:73,78,73,-84
890 WBYTE @95,63:
900 ! Lock out the AA 5001 and the SG 5010 front panels.
910 WBYTE @17:
920 ! Set up AA 5001 for THD Function in percent, filters off, RMS.

```

Fig. 3-6 cont. AA 5001 program example (4050A series).

```

930 PRINT @Aasrim:"FUNC THDP;FILT OFF;RESP RMS"
940 ! Set up AA 5001 to delay sending a readings until settled.
950 ! Set tolerance, number of counts, and number of points.
960 PRINT @Aasrim:"DUS ON;TOL ";_toleran;";COUNTS ";Counts
970 PRINT @Aasrim:"POINTS ";points
980 ! Set up SG 5010 for an RMS balanced output, out on, display freq.
990 PRINT @Ssrim:"VRMS ";Ampliti;";BAL ON;OUT ON;DISP FREQ"
1000 FOR Count=1 TO Nsteps
1010 PRINT @Ssrim:"FREQ ";Frequaray(Count)
1020 PRINT @Aasrim:"SEND"
1030 INPUT @Aasrim:Thdaray(Count)
1040 NEXT Count
1050 CALL Plotloop(Nsteps,Frequaray,Thdaray,Title$,Xtitle$,Ytitle$)
1060 ! Unlock all instruments on the bus.
1070 CALL "RENOFF"
1080 CALL "RENON"
1090 OFF SRQ
1100 END
1110 SUB Sweeplog(Freqstrt,Freqstop,Nsteps,Frequaray)
1120 _steps=Nsteps-1
1130 _stepsize=(LGT(Freqstop)-LGT(Freqstrt))/_steps
1140 Index=0
1150 FOR Count=LGT(Freqstrt) TO LGT(Freqstop) STEP _stepsize
1160 Index=Index+1
1170 Frequaray(Index)=10^Count
1180 NEXT Count
1190 END SUB
1200 SUB Plotloop(Nsteps,Frequaray,Thdaray,Title$,Xtitle$,Ytitle$)
1210 PAGE
1220 WINDOW 0,130,0,100
1230 VIEWPORT 0,130,0,100
1240 PRINT "I ";Title$
1250 PRINT "J"
1260 FOR I=1 TO LEN(Ytitle$)
1270 S%=SEG(Ytitle$,I,1)
1280 PRINT USING 1290:S%
1290 IMAGE A/
1300 NEXT I
1310 MOVE 0,4
1320 PRINT "I ";Xtitle$
1330 VIEWPORT 20,120,20,85
1340 Loy=Thdaray(1)
1350 FOR Index=1 TO Nsteps
1360 IF Thdaray(Index)<Loy THEN
1370 Loy=Thdaray(Index)
1380 END IF
1390 NEXT Index
1400 Hiy=Thdaray(1)
1410 FOR Index=1 TO Nsteps
1420 IF Thdaray(Index)>Hiy THEN
1430 Hiy=Thdaray(Index)
1440 END IF
1450 NEXT Index
1460 Hiy=INT(10*Hiy+1)/10
1470 Loy=INT(10*Loy-1)/10
1480 IF Loy<=0 THEN
1490 Loy=0
1500 END IF
1510 Dif=Hiy-Loy
1520 WINDOW 10,50,Loy,Hiy
1530 MOVE 10,Hiy
1540 DRAW 10,Loy

```

Fig. 3-6 cont. AA 5001 program example (4050A series).



```

1550 DRAW 50,Loy
1560 DRAW 50,Hiy
1570 DRAW 10,Hiy
1580 FOR P=1 TO 4
1590     FOR Q=2 TO 10
1600         T=10*LGT(Q*10^P)
1610         MOVE T,Loy
1620         FOR Tic=Low TO Hiy STEP 0.1*Dif
1630             RMOVE 0,-0.01*Dif
1640             RDRAW 0,0.02*Dif
1650             MOVE T,Tic
1660         NEXT Tic
1670     NEXT Q
1680     MOVE P*10-0.75,Loy-0.1*Dif
1690     PRINT "10"
1700     RMOVE 0.7,0.05*Dif
1710     PRINT P
1720     MOVE T,Loy
1730     DRAW T,Hiy
1740 NEXT P
1750 MOVE P*10-0.75,Loy-0.1*Dif
1760 PRINT "10"
1770 RMOVE 0.7,0.05*Dif
1780 PRINT P
1790 FOR Hor=Low TO Hiy STEP 0.1*Dif
1800     MOVE 4,Hor-0.01*Dif
1810     IF Hor=0 THEN 1840
1820     PRINT USING "2D.3D2A":Hor;"%"
1830     GO TO 1850
1840     PRINT USING "2A2D": " " /Hor
1850     MOVE 10,Hor
1860     DRAW 50,Hor
1870 NEXT Hor
1880 MOVE 10*LGT(Freqaray(1)),Thdaray(1)
1890 FOR Count=2 TO Nsteps
1900     DRAW 10*LGT(Freqaray(Count)),Thdaray(Count)
1910 NEXT Count
1920 HOME
1930 END SUB
1940 ! SRQ Handler
1950 DIM E$(60)
1960 Eflag=0
1970 POLL Addr,Statyt;Aasrim;Ssrim
1980 GOSUB Addr OF 2000,2040
1990 GO TO 2360
2000 PRINT @Aasrim:"ID?;ERR?"
2010 INPUT @Aasrim:E$
2020 Addr=Aasrim
2030 GO TO 2070
2040 PRINT @Ssrim:"ID?;ERR?"
2050 INPUT @Ssrim:E$
2060 Addr=Ssrim
2070 L=POS(E$,"ERR",1)
2080 Error#=SEG(E$,L,10)
2090 Error=VAL(Error#)
2100 S#=SEG(E$,8,6)
2110 IF S#="AA5001" AND Error=601 THEN
2120     Eflag=1
2130 END IF
2140 IF S#="AA5001" AND Error=701 THEN
2150     Eflag=2
2160 END IF
2170 IF S#="AA5001" AND Error=703 THEN
2180     Eflag=3

```

Fig. 3-6 cont. AA 5001 program example (4050A series).

```

2190 END IF
2200 IF S#="AA5001" AND Error=704 THEN
2210   Eflas=4
2220 END IF
2230 IF Eflas=1 THEN
2240   E#=E#&"Display Overrange"
2250 END IF
2260 IF Eflas=2 THEN
2270   E#=E#&"Insufficient Input Level"
2280 END IF
2290 IF Eflas=3 THEN
2300   E#=E#&"Excessive Input Level"
2310 END IF
2320 IF Eflas=4 THEN
2330   E#=E#&"Unsettled Readings"
2340 END IF
2350 PRINT E#,"ADDRESS = ";Addr,"STATUS = ";Stabyt
2360 RETURN
2370 END

```

Fig. 3-6 cont. AA 5001 program example (4050A series).

```

100 ! *****
110 ! ***** TOTAL HARMONIC DISTORTION VERSUS FREQUENCY *****
120 ! *****
130 !
140 ! For 4041: July 22, 1983   Revised: September 28, 1983
150 !
160 ! Copyright (c) 1983 Tektronix, Inc. All rights reserved. This
170 ! software is provided on an "as is" basis without warranty of
180 ! any kind. It is not supported.
190 !
200 ! This program may be reproduced without prior permission, in whole
210 ! or in part, by the original purchaser. Copies must include the
220 ! above copyright and warranty notice.
230 !
240 ! PURPOSE:
250 ! Records the total harmonic distortion of a system to a leveled
260 ! input signal which is swept from 10 Hz to 100 KHz in logarithmic
270 ! fashion. The total number of points is 21. The results are then
280 ! printed out on the 4041 printer.
290 !
300 ! REQUIRED EQUIPMENT:
310 ! AA 5001 Programmable Distortion Analyzer.
320 ! SG 5010 Programmable 160 KHz Oscillator.
330 ! 4041 Controller (V2.0)
340 !
350 ! PROGRAM SEGMENT VARIABLES:
360 ! s#prim   AA 5001 primary address. Factory set to 28.
370 ! ssprim  SG 5010 primary address. Factory set to 25.
380 ! sa      AA 5001 logical unit number.
390 ! ss      SG 5010 logical unit number.
400 ! nsteps  number of frequency steps.
410 ! freqaray array of calculated frequencies.
420 ! thdaray  array of measured total harmonic distortion.
430 ! freqstrt sweep starting frequency.

```

Fig. 3-7. AA 5001 program example (4041).

```

440 ! freqstop      sweep stop frequency.
450 ! toleran      tolerance for Delay Until Settled algorithm in AA 5001.
460 ! counts       number of counts for DUS algorithm in AA 5001.
470 ! points       number of readings to be within tolerance and points.
480 ! amplit       output amplitude of SG 5010.
490 !
500 ! OPERATING INSTRUCTIONS:
510 ! Connect output of SG 5010 to input of Device Under Test.
520 ! Connect output of DUT to input of AA 5001. Address of AA 5001
530 ! must be set to 28 and address of SG 5010 must be set to 25. If
540 ! addresses are different from these factory set addresses, then
550 ! variables aaprim ( AA 5001 primary address ) and ssprim ( SG 5010
560 ! primary address ) must be changed accordingly.
570 !
580 ! ERRORS:
590 ! No GPIB or tape error handlers are linked so 4041 prints default system
600 ! error messages and stops if such errors occur (instrument power is off
610 ! or tape capacity exceeded, etc.).
620 !
630 ! INSTRUMENT CONTROL:
640 ! Polls all instruments on selected port.
650 !
660 ! *****
670 ! Begin main program segment
680 ! Init all
690 ! Select "spib0:"
700 ! On sra then call handler
710 ! Integer aaprim,ssprim,aa,ss,nsteps,points
720 ! Set fuzz 7,1.0E-14,14,1.0E-64
730 ! Aaprim=28
740 ! Ssprim=25
750 ! Aa=280
760 ! Ss=250
770 ! Nsteps=21
780 ! Dim freqaray(nsteps),thdaray(nsteps)
790 ! Freqstrt=10
800 ! Freqstop=1.0E+5
810 ! Toleran=0.1
820 ! Counts=1
830 ! Points=6
840 ! Amplit=1
850 ! Title$="THD VERSUS FREQUENCY"
860 ! Xtitle$="Frequency in Hertz"
870 ! Ytitle$="THD in Percent"
880 ! Open #aa:"spib0(pri="&str$(aaprim)&"):"
890 ! Open #ss:"spib0(pri="&str$(ssprim)&"):"
900 ! Open #2000:"prin:"
910 ! Enable sra
920 !
930 ! Get frequency values for sweep.
940 ! Call losweep(freqstrt,freqstop,nsteps,freqaray)
950 !
960 ! Initialize Instruments
970 ! Wbyte atn(mta,aaprim+32,ssprim+32),"INIT",eoi,atn(unt,unl)
980 ! Lock out the AA 5001 and the SG 5010 front panels.
990 ! Wbyte llo
1000 ! Set up AA 5001 for THD Function in percent, filters off, RMS Response.
1010 ! Print #aa:"FUNC THDP/FILT OFF;RESP RMS"
1020 ! Set up AA 5001 to delay sending a reading until settled.
1030 ! Set tolerance, number of counts, and number of points for DUS algorithm.
1040 ! Print #aa:"DUS ON/TOL";toleran,"COUNTS";counts,"POINTS";points
1050 ! Set up SG 5010 for an RMS balanced output, out on, display freq.

```

Fig. 3-7 cont. AA 5001 program example (4041).

```

1060   Print #ss:"URMS");amp;lit,"BAL ON;OUT ON;DISP FREQ"
1070   For count=1 to nsteps
1080     Print #ss:"FREQ";freqaray(count)
1090     Input prompt "SEND" #aa;thdaray(count)
1100     Next count
1110   Out data:   call printout(nsteps,freqaray,thdaray)
1120   !Unlock all instruments on the bus.
1130   Wbyte ren(0),ren(1)
1140   End
1200   Sub lossweep(freqstrt,freqstop,nsteps var freqaray) local steps,stepsize,index,count
1210     Integer index,steps
1220     Steps=nsteps-1
1230     Stepsize=(lst(freqstop)-lst(freqstrt))/steps
1240     Index=0
1250     For count=lst(freqstrt) to lst(freqstop) step stepsize
1260       Index=index+1
1270       Freqaray(index)=10^count
1280     Next count
1290     Return
1300   End
1400   Sub printout(nsteps,freqaray,thdaray)
1410     Print using "FA4XFA" #2000:"FREQUENCY", "THD"
1420     Print using "20A" #2000:"-----"
1430     For count=1 to nsteps
1440       Print using "7J2A3X6.4GA" #2000:freqaray(count), "Hz",thdaray(count), "%"
1450     Next count
1460     Return
1470   End
1500   Sub handler local e$,statbyt,addr,eflag
1510     Dim e$ to 60
1520     Eflag=0
1530     Poll statbyt,addr
1540     Input prompt "ID?;ERR?" #addr:e$
1550     If seg$(e$,8,6)="AA5001" and valc(e$,pos(e$,"ERR",1))=601 then eflag=1
1560     If seg$(e$,8,6)="AA5001" and valc(e$,pos(e$,"ERR",1))=701 then eflag=2
1570     If seg$(e$,8,6)="AA5001" and valc(e$,pos(e$,"ERR",1))=703 then eflag=3
1580     If seg$(e$,8,6)="AA5001" and valc(e$,pos(e$,"ERR",1))=704 then eflag=4
1590     If eflag=1 then e$=e$&"Display Overranse"
1600     If eflag=1 then e$=e$&"Insufficient Input Level"
1610     If eflag=1 then e$=e$&"Excessive Input Level"
1620     If eflag=1 then e$=e$&"Unsettled Readings"
1630     Print using "FAL=FA2IDL=FA3DL" #2000:e$,"ADDRESS = ",addr,"STATUS = ",statbyt
1640     Resume
1650   End

```

Fig. 3-7 cont. AA 5001 program example (4041).

```

100 ! *****
110 ! ***** DEVICE GAIN VERSUS FREQUENCY *****
120 ! *****
130 !
140 ! For 4050A Series: July 22, 1983      Revised: September 28, 1983
150 !
160 ! Copyright (c) 1983 Tektronix, Inc. All rights reserved. This
170 ! software is provided on an "as is" basis without warranty of
180 ! any kind. It is not supported.
190 !
200 ! This program may be reproduced without prior permission, in
210 ! whole or in part, by the original purchaser. Copies must
220 ! include the above copyright and warranty notice.
230 !
240 ! PURPOSE:
250 ! Records the total gain in decibels of a system to a leveled
260 ! input signal which is swept from 10 Hz-100 KHz in logarithmic
270 ! fashion. The total number of points is 21 counting endpoints.
280 ! The gain is referenced to the gain at 1 KHz. The results are
290 ! then plotted on the 4050A Series screen.
300 !
310 ! REQUIRED EQUIPMENT:
320 ! AA 5001 Programmable Distortion Analyzer.
330 ! SG 5010 Programmable 160 KHz Oscillator.
340 ! 4050A Series Controller
350 !
360 ! PROGRAM SEGMENT VARIABLES:
370 ! aaprim      AA 5001 primary address. Factory set to 28.
380 ! ssprim      SG 5010 primary address. Factory set to 25.
390 ! nsteps      number of frequency steps.
400 ! freqarray   array of calculated frequencies.
410 ! levarray    array of measured levels.
420 ! freqstrt    sweep starting frequency.
430 ! freqstop    sweep stop frequency.
440 ! _toleran    tolerance for Delay Until Settled algorithm.
450 ! Counts      number of counts for IUS algorithm in AA 5001.
460 ! _points     number of readings to be within tolerance and
470 ! counts.
480 ! amplit      output amplitude of SG 5010.
490 ! midfreq     midband frequency.
500 !
510 ! OPERATING INSTRUCTIONS:
520 ! Connect output of SG 5010 to input of Device Under Test.
530 ! Connect output of DUT to input of AA 5001. Address of AA 5001
540 ! must be set to 28 and address of SG 5010 must be set to 25. If
550 ! addresses are different from these factory set addresses, then
560 ! variables aaprim ( AA 5001 primary address) and ssprim
570 ! (SG 5010 primary address ) must be changed accordingly.
580 !
590 ! ERRORS:
600 ! AA 5001 and SG 5010 addresses must be set to 28 and 25
610 ! respectively or program assignments of variables aaprim
620 ! and ssprim changed in program.
630 !
640 ! INSTRUMENT CONTROL:
650 ! Polls instruments on assigned addresses (AA 5001 and SG 5010).
660 !
670 ! *****
680 ! Begin main program segment
690 INIT
700 PAGE
710 Aaprim=28
720 Ssprim=25

```

Fig. 3-8. AA 5001 program example (4050A series).

```

730 Nsteps=21
740 DIM Freqaray(Nsteps),Levaray(Nsteps)
750 Freqstrt=10
760 Freqstop=100000
770 toleran=0.1
780 Counts=1
790 _points=6
800 Amplit=1
810 Midfreq=1000
820 Title$="GAIN VERSUS FREQUENCY"
830 Xtitle$="Frequency in Hertz"
840 Ytitle$="Gain in dB"
850 ON SRQ THEN 2180
860 !
870 ! Get frequency values for sweep.
880 CALL Sweeplos(Freqstrt,Freqstop,Nsteps,Freqaray)
890 !
900 ! Initialize Instruments
910 WBYTE @Aaprim+32,Ssprim+32:73,78,73,-84
920 WBYTE @95,63:
930 ! Lock out the AA 5001 and the SG 5010 front panels.
940 WBYTE @17:
950 ! Set up AA 5001 for LEVEL Function in volts, filters off, RMS.
960 PRINT @Aaprim:"FUNC VOLT;FILT OFF;RESP RMS"
970 ! Set up AA 5001 to delay sending a reading until settled.
980 ! Set tolerance, number of counts, and number of points.
990 PRINT @Aaprim:"DUS ON;TOL ";toleran);COUNTS ";Counts
1000 PRINT @Aaprim:"POINTS ";_points
1010 ! Set up SG 5010 for RMS balanced output, out on, display freq.
1020 PRINT @Ssprim:"VRMS ";Amplit;";BAL ON;OUT ON;DISP FREQ"
1030 ! Acquire gain at midband.
1040 PRINT @Ssprim:"FREQ ";Midfreq
1050 PRINT @Aaprim:"SEND"
1060 INPUT @Aaprim:Ref
1070 FOR Count=1 TO Nsteps
1080 PRINT @Ssprim:"FREQ ";Freqaray(Count)
1090 PRINT @Aaprim:"SEND"
1100 INPUT @Aaprim:Levaray(Count)
1110 ! Change reading to dB referenced to the gain at 1 KHz.
1120 Levaray(Count)=20*LGT(Levaray(Count)/Ref)
1130 NEXT Count
1140 CALL Plotloop(Nsteps,Freqaray,Levaray,Title$,Xtitle$,Ytitle$)
1150 ! Unlock all instruments on the bus.
1160 CALL "RENOFF"
1170 CALL "RENON"
1180 END
1190 SUB Sweeplos(Freqstrt,Freqstop,Nsteps,Freqaray)
1200 _steps=Nsteps-1
1210 _stepsize=(LGT(Freqstop)-LGT(Freqstrt))/_steps
1220 Index=0
1230 FOR Count=LGT(Freqstrt) TO LGT(Freqstop) STEP _stepsize
1240 Index=Index+1
1250 Freqaray(Index)=10^Count
1260 NEXT Count
1270 END SUB
1280 SUB Plotloop(Nsteps,Freqaray,Levaray,Title$,Xtitle$,Ytitle$)
1290 PAGE
1300 WINDOW 0,130,0,100
1310 VIEWPORT 0,130,0,100
1320 PRINT "I ";Title$
1330 PRINT "JJJJJ"
1340 FOR I=1 TO LEN(Ytitle$)
1350 S$=SEG(Ytitle$,I,1)

```

Fig. 3-8 cont. AA 5001 program example (4050A series).

```

1360     PRINT USING 1370:S$
1370     IMAGE A/
1380     NEXT I
1390     MOVE 0,4
1400     PRINT "I      ";Xtitles$
1410     VIEWPORT 20,120,20,85
1420     Low=Levaray(1)
1430     FOR Index=1 TO Nsteps
1440         IF Levaray(Index)<Low THEN
1450             Low=Levaray(Index)
1460         END IF
1470     NEXT Index
1480     High=Levaray(1)
1490     FOR Index=1 TO Nsteps
1500         IF Levaray(Index)>High THEN
1510             High=Levaray(Index)
1520         END IF
1530     NEXT Index
1540     J=-5
1550     Flag=0
1560     DO
1570         J=J+5
1580         IF High>J AND High<=J+5 THEN
1590             High=J+5
1600             Flag=1
1610         END IF
1620     EXIT IF Flag
1630     LOOP
1640     J=5
1650     Flag=0
1660     DO
1670         J=J-5
1680         IF Low<J AND Low=>J-5 THEN
1690             Low=J-5
1700             Flag=1
1710         END IF
1720     EXIT IF Flag
1730     LOOP
1740     Dif=High-Low
1750     WINDOW 10,50,Low,High
1760     MOVE 10,High
1770     DRAW 10,Low
1780     DRAW 50,Low
1790     DRAW 50,High
1800     DRAW 10,High
1810     FOR P=1 TO 4
1820         FOR Q=2 TO 10
1830             T=10*LG(T*(Q*10^P))
1840             MOVE T,Low
1850             FOR Tic=Low TO High STEP 5
1860                 RMOVE 0,-0.01*Dif
1870                 RDRAW 0,0.02*Dif
1880                 MOVE T,Tic
1890             NEXT Tic
1900         NEXT Q
1910         MOVE P*10-0.75,Low-0.1*Dif
1920         PRINT "10"
1930         RMOVE 0.7,0.05*Dif
1940         PRINT P
1950         MOVE T,Low
1960         DRAW T,High
1970     NEXT P
1980     MOVE P*10-0.75,Low-0.1*Dif

```

Fig. 3-8 cont. AA 5001 program example (4050A series).

```

1990 PRINT "10"
2000 RMOVE 0.7,0.05*Dif
2010 PRINT P
2020 FOR Hor=Low TO Hig STEP 5
2030     MOVE 4,Hor-0.01*Dif
2040     IF Hor=0 THEN 2070
2050     PRINT USING "3D.2D2A":Hor;"dB"
2060     GO TO 2080
2070     PRINT USING "2A2D": "  "/Hor
2080     MOVE 10,Hor
2090     DRAW 50,Hor
2100 NEXT Hor
2110 MOVE 10*LGT(Freqaray(1)),Levaray(1)
2120 FOR Count=2 TO Nsteps
2130     DRAW 10*LGT(Freqaray(Count)),Levaray(Count)
2140 NEXT Count
2150 HOME
2160 END SUB
2170 ! SRQ Handler
2180 DIM E$(60)
2190 Eflag=0
2200 POLL Addr,Stabyt;A$prim;S$prim
2210 GOSUB Addr OF 2230,2270
2220 GO TO 2590
2230 PRINT @A$prim:"ID?;ERR?"
2240 INPUT @A$prim:E$
2250 Addr=A$prim
2260 GO TO 2300
2270 PRINT @S$prim:"ID?;ERR?"
2280 INPUT @S$prim:E$
2290 Addr=S$prim
2300 L=POS(E$,"ERR",1)
2310 Error#=SEG(E$,L,10)
2320 Error=VAL(Error#)
2330 S#=SEG(E$,8,6)
2340 IF S#="AA5001" AND Error=601 THEN
2350     Eflag=1
2360 END IF
2370 IF S#="AA5001" AND Error=701 THEN
2380     Eflag=2
2390 END IF
2400 IF S#="AA5001" AND Error=703 THEN
2410     Eflag=3
2420 END IF
2430 IF S#="AA5001" AND Error=704 THEN
2440     Eflag=4
2450 END IF
2460 IF Eflag=1 THEN
2470     E$=E$&"Display Overrange"
2480 END IF
2490 IF Eflag=2 THEN
2500     E$=E$&"Insufficient Input Level"
2510 END IF
2520 IF Eflag=3 THEN
2530     E$=E$&"Excessive Input Level"
2540 END IF
2550 IF Eflag=4 THEN
2560     E$=E$&"Unsettled Readings"
2570 END IF
2580 PRINT E$,"ADDRESS = ";Addr,"STATUS = ";Stabyt
2590 RETURN
2600 END

```

Fig. 3-8 cont. AA 5001 program example (4050A series).



```

100 | *****
110 | ***** DEVICE GAIN VERSUS FREQUENCY *****
120 | *****
130 |
140 | For 4041: July 22, 1983      Revised: September 28, 1983
150 |
160 | Copyright (c) 1983 Tektronix, Inc. All rights reserved. This
170 | software is provided on an "as is" basis without warranty of
180 | any kind. It is not supported.
190 |
200 | This program may be reproduced without prior permission, in whole
210 | or in part, by the original purchaser. Copies must include the
220 | above copyright and warranty notice.
230 |
240 | PURPOSE:
250 | Records the total gain in decibels of a system to a leveled
260 | input signal which is swept from 10 Hz to 100 KHz in logarithmic
270 | fashion. The total number of points is 21 counting the endpoints.
280 | The gain is referenced to the gain at 1 KHz. The results are then
290 | printed out on the 4041 printer.
300 |
310 | REQUIRED EQUIPMENT:
320 | AA 5001 Programmable Distortion Analyzer.
330 | SG 5010 Programmable 160 KHz Oscillator.
340 | 4041 Controller (V2.0)
350 |
360 | PROGRAM SEGMENT VARIABLES:
370 | aaprim      AA 5001 primary address. Factory set to 28.
380 | sspri      SG 5010 primary address. Factory set to 25.
390 | aa         AA 5001 logical unit number.
400 | ss         SG 5010 logical unit number.
410 | nsteps     number of frequency steps.
420 | freqarray  array of calculated frequencies.
430 | levelarray array of measured levels.
440 | freqstrt   sweep starting frequency.
450 | freqstop   sweep stop frequency.
460 | toleran    tolerance for Delay Until Settled algorithm in AA 5001.
470 | counts     number of counts for DUS algorithm in AA 5001.
480 | points     number of readings to be within tolerance and points.
490 | amplit     output amplitude of SG 5010.
500 | midfreq    midband frequency.
510 |
520 | OPERATING INSTRUCTIONS:
530 | Connect output of SG 5010 to input of Device Under Test.
540 | Connect output of DUT to input of AA 5001. Address of AA 5001
550 | must be set to 28 and address of SG 5010 must be set to 25. If
560 | addresses are different from these factory set addresses, then
570 | variables aaprim ( AA 5001 primary address) and sspri ( SG 5010
580 | primary address ) must be changed accordingly.
590 |
600 | ERRORS:
610 | No GPIB or tape error handlers are linked so 4041 prints default system
620 | error messages and stops if such errors occur (instrument power is off
630 | or tape capacity exceeded, etc.).
640 |
650 | INSTRUMENT CONTROL:
660 | Polls all instruments on selected port.
670 |
680 | *****
690 | Begin main program segment
700 | Init all
710 | Select "spib0:"
720 | On sra then call handler

```

Fig. 3-9. AA 5001 program example (4041).

```

730   Integer aasprim,ssprim,aa,ss,nsteps,points
740   Set fuzz 7,1.0E-14,14,1.0E-64
750   Aasprim=28
760   Ssprim=25
770   Aa=280
780   Ss=250
790   Nsteps=21
800   Dim freqaray(nsteps),levaray(nsteps)
810   Freqstr=10
820   Freqstop=1.0E+5
830   Toleran=0.1
840   Counts=1
850   Points=6
860   Amplit=1
870   Midfreq=1000.0
880   Title$="GAIN VERSUS FREQUENCY"
890   Xtitle$="Frequency in Hertz"
900   Ytitle$="Gain in dB"
910   Open #aa:"spib0(pri="&str$(aasprim)&"):"
920   Open #ss:"spib0(pri="&str$(ssprim)&"):"
930   Open #2000:"pri:"
940   Enable srs
950   !
960   ! Get frequency values for sweep.
970   Call lossweep(freqstr,freqstop,nsteps,freqaray)
980   !
990   ! Initialize Instruments
1000  Wbyte atn(mta,aasprim+32,ssprim+32),"INIT",eoi,atn(unt,unt)
1010  ! Lock out the AA 5001 and the SG 5010 front panels.
1020  Wbyte llb
1030  ! Set up AA 5001 for LEVEL Function in volts, filters off, RMS Response.
1040  Print #aa:"FUNC VOLT;FILT OFF;RESP RMS"
1050  ! Set up AA 5001 to delay sending a readings until settled.
1060  ! Set tolerance, number of counts, and number of points for BUS algorithm.
1070  Print #aa:"BUS ON;TOL";toleran,"COUNTS";counts,"POINTS";points
1080  ! Set up SG 5010 for an RMS balanced output, out on, display freq.
1090  Print #ss:"VRMS";amplit,"BAL ON;OUT ON;DISP FREQ"
1100  ! Acquire gain at midband.
1110  Print #ss:"FREQ";midfreq
1120  Input prompt "SEND" #aa:ref
1130  For count=1 to nsteps
1140    Print #ss:"FREQ";freqaray(count)
1150    Input prompt "SEND" #aa:levaray(count)
1160  ! Change readings to dB referenced to the gain at 1 KHz.
1170    Levaray(count)=20*lst(levaray(count)/ref)
1180    Next count
1190  Out_data: call printout(nsteps,freqaray,levaray)
1200  ! Unlock all instruments on the bus.
1210  Wbyte ren(0),ren(1)
1220  End
1300  Sub lossweep(freqstr,freqstop,nsteps var freqaray) local steps,stepsize,index,count
1310  Integer index,steps
1320  Steps=nsteps-1
1330  Stepsize=(lst(freqstop)-lst(freqstr))/steps
1340  Index=0
1350  For count=lst(freqstr) to lst(freqstop) step stepsize
1360    Index=index+1
1370    Freqaray(index)=10^count
1380    Next count
1390  Return
1400  End
1500  Sub printout(nsteps,freqaray,levaray)
1510  Print using "FA4XFA" #2000:"FREQUENCY","LEVEL"

```

Fig. 3-9 cont. AA 5001 program example (4041).

```

1520   Print using "20A" #2000:"-----"
1530   For count=1 to nsteps
1540     Print using "7J2AX7.202A" #2000:freqaray(count),"Hz",levaray(count),"dB"
1550     Next count
1560   Return
1570   End
1600 Sub handler local e$,stabyt,addr,eflag
1610   Dim e$ to 60
1620   Eflag=0
1630   Poll stabyt,addr
1640   Input prompt "ID?;ERR?" #addr:e$
1650   If ses$(e$,8,6)="AA5001" and valc(e$,pos(e$,"ERR",1))=601 then eflag=1
1660   If ses$(e$,8,6)="AA5001" and valc(e$,pos(e$,"ERR",1))=701 then eflag=2
1670   If ses$(e$,8,6)="AA5001" and valc(e$,pos(e$,"ERR",1))=703 then eflag=3
1680   If ses$(e$,8,6)="AA5001" and valc(e$,pos(e$,"ERR",1))=704 then eflag=4
1690   If eflag=1 then e$=e$&"Display Overranse"
1700   If eflag=2 then e$=e$&"Insufficient Input Level"
1710   If eflag=3 then e$=e$&"Excessive Input Level"
1720   If eflag=4 then e$=e$&"Unsettled Reading"
1730   Print using "FAL=FA2DL=FA3DL" #2000:e$,"ADDRESS = ",addr,"STATUS = ",stabyt
1740   Resume
1750   End

```

Fig. 3-9 cont. AA 5001 program example (4041).

```

100 | *****
110 | ***** RIAA EQUALIZATION VERIFICATION *****
120 | *****
130 |
140 | For 4050A Series: July 22, 1983      Revised: September 28, 1983
150 |
160 | Copyright (c) 1983 Tektronix, Inc. All rights reserved. This
170 | software is provided on an "as is" basis without warranty of
180 | any kind. It is not supported.
190 |
200 | This program may be reproduced without prior permission, in
210 | whole or in part, by the original purchaser. Copies must
220 | include the above copyright and warranty notice.
230 |
240 | PURPOSE:
250 | Checks the accuracy of an RIAA equalization network on playback.
260 | The frequency is swept from 20 Hz to 20 KHz, the input
270 | amplitude to the network is varied according to the RIAA
280 | response equation. The output of the DUT should remain at the
290 | level that it was at 1 KHz. The measured results are graphed as
300 | deviation from level at 1 KHz. The total number of points is 21.
310 |
320 | REQUIRED EQUIPMENT:
330 | AA 5001 Programmable Distortion Analyzer.
340 | SG 5010 Programmable 160 KHz Oscillator.
350 | 4050A Series Controller
360 |
370 | PROGRAM SEGMENT VARIABLES:
380 | aaprim      AA 5001 primary address. Factory set to 28.
390 | sspriam     SG 5010 primary address. Factory set to 25.
400 | nsteps      number of frequency steps.
410 | freqarray   array of calculated frequencies.
420 | levelarray  array of measured levels. Measured in volts.
430 | rias        array of rias equalization parameters.
440 | freqstrt    sweep starting frequency.
450 | freqstop    sweep stop frequency.
460 | _toleran    tolerance for Delay Until Settled algorithm.
470 | counts      number of counts for DUS algorithm in AA 5001.
480 | _points     number of readings to be within tolerance and
490 |             counts.
500 | midamp      midband (1 KHz) output amplitude of SG 5010.
510 |
520 | OPERATING INSTRUCTIONS:
530 | Connect output of SG 5010 to input of Device Under Test.
540 | Connect output of DUT to input of AA 5001. Address of AA 5001
550 | must be set to 28 and address of SG 5010 must be set to 25.
560 | If addresses are different from these factory set addresses,
570 | then variables aaprim (AA 5001 primary address) and sspriam
580 | (SG 5010 primary address ) must be changed accordingly.
590 |
600 | ERRORS:
610 | AA 5001 and SG 5010 addresses must be set to 28 and 25
620 | respectively or program assignments of variables aaprim
630 | and sspriam changed in program.
640 |
650 | INSTRUMENT CONTROL:
660 | Polls instruments on assigned addresses (AA 5001 and SG 5010).
670 |
680 | *****
690 | Begin main program segment
700 INIT
710 PAGE
720 Aaprim=28

```

Fig. 3-10. AA 5001 program example (4050A series).

```

730 Ssprim=25
740 Nsteps=21
750 DIM Freqarray(Nsteps),Levaray(Nsteps),Riaa(Nsteps)
760 Freqstrt=20
770 Freqstop=20000
780 toleran=0.1
790 Counts=1
800 points=6
810 Midamp=1
820 Title$="RIAA EQUALIZATION VERIFICATION"
830 Xtitle$="Frequency in Hertz"
840 Ytitle$="Deviation in dB"
850 ON SRQ THEN 1980
860 !
870 ! Get frequency values for sweep.
880 CALL Riaaveri(Freqstrt,Freqstop,Nsteps,Freqarray,Riaa)
890 !
900 ! Initialize Instruments
910 WBYTE @Aaprim+32,Ssprim+32:73,78,73,-84
920 WBYTE @95,63:
930 ! Lock out the AA 5001 and the SG 5010 front panels.
940 WBYTE @17:
950 ! Set up AA 5001 for LEVEL Function in volts, filters off, RMS.
960 PRINT @Aaprim:"FUNC VOLT;FILT OFF;RESP RMS"
970 ! Set up AA 5001 to delay sending a reading until settled.
980 ! Set toleran, number of counts, and number of points.
990 PRINT @Aaprim:"BUS ON;TOL ";toleran;"COUNTS ";Counts
1000 PRINT @Aaprim:"POINTS ";points
1010 ! Set up SG 5010 for RMS balanced output, out on, display freq.
1020 PRINT @Ssprim:"VRMS ";Midamp;"BAL ON;OUT ON;DISP FREQ"
1030 ! Acquire gain at 1 KHz.
1040 PRINT @Ssprim:"FREQ 1E3"
1050 PRINT @Aaprim:"SEND"
1060 INPUT @Aaprim:Ref
1070 FOR Count=1 TO Nsteps
1080 PRINT @Ssprim:"AMPL ";Midamp/Riaa(Count);"FREQ ";Freqarray(Count)
1090 PRINT @Aaprim:"SEND"
1100 INPUT @Aaprim:Levaray(Count)
1110 ! Calculate dB level from voltage readings for added accuracy.
1120 Levaray(Count)=20*LGT(Levaray(Count)/Ref)
1130 NEXT Count
1140 CALL Plotloop(Nsteps,Freqarray,Levaray,Title$,Xtitle$,Ytitle$)
1150 ! Unlock all instruments on the bus.
1160 CALL "REN OFF"
1170 CALL "REN ON"
1180 OFF SRQ
1190 END
1200 SUB Riaaveri(Freqstrt,Freqstop,Nsteps,Freqarray,Riaa)
1210 _steps=Nsteps-1
1220 _stepsize=(LGT(Freqstop)-LGT(Freqstrt))/_steps
1230 T1sq=(7.5E-5*2*PI*1000)^2
1240 T2sq=(3.184E-4*2*PI*1000)^2
1250 T3sq=(0.003184*2*PI*1000)^2
1260 Ref=SQR((1+T2sq)/((1+T1sq)*(1+T3sq)))
1270 Index=0
1280 FOR Count=LGT(Freqstrt) TO LGT(Freqstop) STEP _stepsize
1290 Index=Index+1
1300 Freqarray(Index)=10^Count
1310 T1sq=(7.5E-5*2*PI*10^Count)^2
1320 T2sq=(3.184E-4*2*PI*10^Count)^2
1330 T3sq=(0.003184*2*PI*10^Count)^2
1340 Temp=SQR((1+T2sq)/((1+T1sq)*(1+T3sq)))

```

Fig. 3-10 cont. AA 5001 program example (4050A series).

```

1350     Riaa(Index)=10*Temp
1360     NEXT Count
1370 END SUB
1380 SUB Plotloop(Nsteps,Freqaray,Levaray,Title$,Xtitles$,Ytitles$)
1390     PAGE
1400     WINDOW 0,130,0,100
1410     VIEWPORT 0,130,0,100
1420     PRINT "I      ";Title$
1430     PRINT "J"
1440     FOR I=1 TO LEN(Ytitles$)
1450         S%=SEG(Ytitles$,I,1)
1460         PRINT USING 1470:S$
1470         IMAGE A/
1480     NEXT I
1490     MOVE 0,4
1500     PRINT "I      ";Xtitles$
1510     VIEWPORT 20,120,20,85
1520     Loy=-1
1530     Hiy=1
1540     Dif=Hiy-Loy
1550     WINDOW 10,50,Loy,Hiy
1560     MOVE 10,Hiy
1570     DRAW 10,Loy
1580     DRAW 50,Loy
1590     DRAW 50,Hiy
1600     DRAW 10,Hiy
1610     FOR P=1 TO 4
1620         FOR Q=2 TO 10
1630             T=10*LG(T(Q*10^P))
1640             MOVE T,Loy
1650             FOR Tic=Loy TO Hiy STEP 0.1*Dif
1660                 RMOVE 0,-0.01*Dif
1670                 RDRAW 0,0.02*Dif
1680                 MOVE T,Tic
1690             NEXT Tic
1700         NEXT Q
1710         MOVE P*10-0.75,Loy-0.1*Dif
1720         PRINT "10"
1730         RMOVE 0.7,0.05*Dif
1740         PRINT P
1750         MOVE T,Loy
1760         DRAW T,Hiy
1770     NEXT P
1780     MOVE P*10-0.75,Loy-0.1*Dif
1790     PRINT "10"
1800     RMOVE 0.7,0.05*Dif
1810     PRINT P
1820     FOR Hor=Loy TO Hiy STEP 0.1*Dif
1830         MOVE 4,Hor-0.01*Dif
1840         IF Hor=0 THEN 1870
1850         PRINT USING "2B.2B2A":Hor;"dB"
1860         GO TO 1880
1870         PRINT USING "2A2D": " ";Hor
1880         MOVE 10,Hor
1890         DRAW 50,Hor
1900     NEXT Hor
1910     MOVE 10*LG(T(Freqaray(1)),Levaray(1)
1920     FOR Count=2 TO Nsteps
1930         DRAW 10*LG(T(Freqaray(Count)),Levaray(Count)
1940     NEXT Count
1950     HOME
1960 END SUB
1970     ! SRQ Handler

```

Fig. 3-10 cont. AA 5001 program example (4050A series).

```
1980 DIM E$(60)
1990 Eflag=0
2000 POLL Addr,Stabyt;Aaprim;Ssprim
2010 GOSUB Addr OF 2030,2070
2020 GO TO 2390
2030 PRINT @Aaprim:"ID?;ERR?"
2040 INPUT @Aaprim:E$
2050 Addr=Aaprim
2060 GO TO 2100
2070 PRINT @Ssprim:"ID?;ERR?"
2080 INPUT @Ssprim:E$
2090 Addr=Ssprim
2100 L=POS(E$,"ERR",1)
2110 Error$=SEG(E$,L,10)
2120 Error=VAL(Error$)
2130 S$=SEG(E$,8,6)
2140 IF S$="AA5001" AND Error=601 THEN
2150   Eflag=1
2160 END IF
2170 IF S$="AA5001" AND Error=701 THEN
2180   Eflag=2
2190 END IF
2200 IF S$="AA5001" AND Error=703 THEN
2210   Eflag=3
2220 END IF
2230 IF S$="AA5001" AND Error=704 THEN
2240   Eflag=4
2250 END IF
2260 IF Eflag=1 THEN
2270   E$=E$&"Display Override"
2280 END IF
2290 IF Eflag=2 THEN
2300   E$=E$&"Insufficient Input Level"
2310 END IF
2320 IF Eflag=3 THEN
2330   E$=E$&"Excessive Input Level"
2340 END IF
2350 IF Eflag=4 THEN
2360   E$=E$&"Unsettled Readings"
2370 END IF
2380 PRINT E$,"ADDRESS = ";Addr,"STATUS = ";Stabyt
2390 RETURN
2400 END
```

Fig. 3-10 cont. AA 5001 program example (4050A series).

```

100 ! *****
110 ! ***** RIAA EQUALIZATION VERIFICATION *****
120 ! *****
130 !
140 ! For 4041: July 22, 1983      Revised: September 28, 1983
150 !
160 ! Copyright (c) 1983 Tektronix, Inc. All rights reserved. This
170 ! software is provided on an "as is" basis without warranty of
180 ! any kind. It is not supported.
190 !
200 ! This program may be reproduced without prior permission, in whole
210 ! or in part, by the original purchaser. Copies must include the
220 ! above copyright and warranty notice.
230 !
240 ! PURPOSE:
250 ! Checks the accuracy of an RIAA equalization network on playback. The
260 ! frequency is swept from 20 Hz to 20 KHz; the input amplitude to the
270 ! network is varied according to the RIAA response equation. The output
280 ! of the Device Under Test should remain at the same level that it was
290 ! at 1 KHz. The measured results are printed out as deviation from the
300 ! level at 1 KHz. The total number of points is 21.
310 !
320 ! REQUIRED EQUIPMENT:
330 ! AA 5001 Programmable Distortion Analyzer.
340 ! SG 5010 Programmable 160 KHz Oscillator.
350 ! 4041 Controller (V2.0)
360 !
370 ! PROGRAM SEGMENT VARIABLES:
380 ! saddr    AA 5001 primary address. Factory set to 28.
390 ! saddr    SG 5010 primary address. Factory set to 25.
400 ! aa      AA 5001 logical unit number.
410 ! ss      SG 5010 logical unit number.
420 ! nsteps  number of frequency steps.
430 ! farray  array of calculated frequencies.
440 ! larray  array of measured levels. Measured in volts; converted to dB.
450 ! riaz    array of riaz equalization parameters.
460 ! freqstr sweep starting frequency.
470 ! freqstop sweep stop frequency.
480 ! toleran tolerance for Delay Until Settled algorithm in AA 5001.
490 ! counts  number of counts for DUS algorithm in AA 5001.
500 ! points  number of readings to be within tolerance and points.
510 ! midamp  midband (1 KHz) output amplitude of SG 5010.
520 !
530 ! OPERATING INSTRUCTIONS:
540 ! Connect output of SG 5010 to input of Device Under Test.
550 ! Connect output of DUT to input of AA 5001. Address of AA 5001
560 ! must be set to 28 and address of SG 5010 must be set to 25. If
570 ! addresses are different from these factory set addresses, then
580 ! variables saddr ( AA 5001 primary address ) and saddr ( SG 5010
590 ! primary address ) must be changed accordingly.
600 !
610 ! ERRORS:
620 ! No GPIB or tape error handlers are linked so 4041 prints default system
630 ! error messages and stops if such errors occur (instrument power is off
640 ! or tape capacity exceeded, etc.).
650 !
660 ! INSTRUMENT CONTROL:
670 ! Polls all instruments on selected port.
680 !
690 ! *****
700 ! Begin main program segment
710 ! Init all
720 ! Select "spib0:"

```

Fig. 3-11. AA 5001 program example (4041).



```

730   On sra then call handler
740   Integer aaprim,ssprim,aa,ss,nsteps,points
750   Set fuzz 7,1.0E-14,14,1.0E-64
760   Aaprim=28
770   Ssprim=25
780   Aa=280
790   Ss=250
800   Nsteps=21
810   Dim freqaray(nsteps),levaray(nsteps),riaa(nsteps)
820   Freqstrt=20
830   Freqstop=2.0E+4
840   Toleran=0.1
850   Counts=1
860   Points=6
870   Midamp=1
880   Title$="RIAA EQUALIZATION VERIFICATION"
890   Xtitle$="Frequency in Hertz"
900   Ytitle$="Deviation in dB"
910   Open #aa:"spib0(pri="&str$(aaprim)&"):"
920   Open #ss:"spib0(pri="&str$(ssprim)&"):"
930   Open #2000:"prin:"
940   Enable sra
950   !
960   ! Get frequency values for sweep.
970   Call riaaveri(freqstrt,freqstop,nsteps,freqaray,riaa)
980   !
990   ! Initialize Instruments
1000  Wbyte atn(mta,aaprim+32,ssprim+32),"INIT",eoi,atn(unt,unt)
1010  ! Lock out the AA 5001 and the SG 5010 front panels.
1020  Wbyte llo
1030  ! Set up AA 5001 for LEVEL Function in volts, filters off, RMS Response.
1040  Print #aa:"FUNC VOLT;FILT OFF;RESP RMS"
1050  ! Set up AA 5001 to delay sending a reading until settled.
1060  ! Set tolerance, number of counts, and number of points.
1070  Print #aa:"DUS ON;TOL";toleran,"COUNTS";counts,"POINTS";points
1080  ! Set up SG 5010 for an RMS balanced output, out on, display freq.
1090  Print #ss:"VRMS";midamp,"BAL ON;OUT ON;DISP FREQ"
1100  ! Acquire gain at 1 KHz.
1110  Print #ss:"FREQ 1E3"
1120  Input prompt "SEND" #aa:ref
1130  For count=1 to nsteps
1140     Print #ss:"AMPL";midamp/riaa(count),"FREQ";freqaray(count)
1150     Wait 0.5
1160     Input prompt "SEND" #aa:levaray(count)
1170     ! Calculate dB level from voltage readings for added accuracy.
1180     Levaray(count)=20*lst(levaray(count)/ref)
1190     Next count
1200  Out_data: call printout(nsteps,freqaray,levaray)
1210  ! Unlock all instruments on the bus.
1220  Wbyte ren(0),ren(1)
1230  End
1300  Sub riaaveri(freqstrt,freqstop,nsteps var freqaray,riaa) local steps,stepsize,index,count
1310  Integer index,steps
1320  Steps=nsteps-1
1330  Stepsize=(lst(freqstop)-lst(freqstrt))/steps
1340  T1sq=(7.5E-5*2*pi*1000.0)^2
1350  T2sq=(3.184E-4*2*pi*1000.0)^2
1360  T3sq=(0.003184*2*pi*1000.0)^2
1370  Ref=sqr((1+t1sq)/((1+t1sq)*(1+t3sq)))
1380  Index=0
1390  For count=lst(freqstrt) to lst(freqstop) step stepsize
1400     Index=index+1
1410     Freqaray(index)=10^count

```

Fig. 3-11 cont. AA 5001 program example (4041).

```

1420      T1sq=(7.5E-5*2*pi*10^count)^2
1430      T2sq=(3.184E-4*2*pi*10^count)^2
1440      T3sq=(0.003184*2*pi*10^count)^2
1450      Temp=sqr((1+t2sq)/((1+t1sq)*(1+t3sq)))
1460      Riia(index)=10*temp
1470      Next count
1480      Return
1490      End
1600 Sub printout(nsteps,freqaray,levaray)
1610      Print usins "FA2XFA" #2000:"FREQUENCY","DEVIATION"
1620      Print usins "20A" #2000:"-----"
1630      For count=1 to nsteps
1640          Print usins "7J2AX7.262A" #2000:freqaray(count),"Hz",levaray(count),"dB"
1650      Next count
1660      Return
1670      End
1700 Sub handler local e$
1710      Dim e$ to 60
1720      Eflag=0
1730      Poll stabst,addr
1740      Input promet "ID?/ERR?" #addr:e$
1750      If ses$(e$,8,6)="AA5001" and valc(e$,pos(e$,"ERR",1))=601 then eflag=1
1760      If ses$(e$,8,6)="AA5001" and valc(e$,pos(e$,"ERR",1))=701 then eflag=2
1770      If ses$(e$,8,6)="AA5001" and valc(e$,pos(e$,"ERR",1))=703 then eflag=3
1780      If ses$(e$,8,6)="AA5001" and valc(e$,pos(e$,"ERR",1))=704 then eflag=4
1790      If eflag=1 then e$=e$&"Display Overrange"
1800      If eflag=2 then e$=e$&"Insufficient Input Level"
1810      If eflag=3 then e$=e$&"Excessive Input Level"
1820      If eflag=4 then e$=e$&"Unsettled Reading"
1830      Print usins "FAL=FA2DL=FA3DL" #2000:e$,"ADDRESS = ",addr,"STATUS = ",stabst
1840      Resume
1850      End

```

Fig. 3-11 cont. AA 5001 program example (4041).

```

100 ! *****
110 ! ***** TOTAL HARMONIC DISTORTION VERSUS OUTPUT POWER *****
120 ! *****
130 !
140 ! For 4050A Series: July 22, 1983      Revised: September 28, 1983
150 !
160 ! Copyright (c) 1983 Tektronix, Inc. All rights reserved. This
170 ! software is provided on an "as is" basis without warranty of
180 ! any kind. It is not supported.
190 !
200 ! This program may be reproduced without prior permission, in
210 ! whole or in part, by the original purchaser. Copies must
220 ! include the above copyright and warranty notice.
230 !
240 ! PURPOSE:
250 ! Records the total harmonic distortion of a system to a
260 ! logarithmically increasing input signal at a frequency
270 ! determined by variable testfreq.
280 ! The voltage is increased from the value of the variable
290 ! voltstrt to the value of the variable voltstop until the
300 ! distortion is greater than or equal to the value of the
310 ! variable maxdist. When this point is reached, the output of
320 ! the SG 5010 is changed to the previous output and a
330 ! new increment size is used. This technique allows for the
340 ! definition of the knee of the curve. In order for the
350 ! algorithm to produce useful results, the value of variable
360 ! voltstop must produce a distortion equal to or greater
370 ! than the value of the variable maxdist.
380 ! The results are then plotted on the 4050A Series screen.
390 ! The total number of points is 21.
400 !
410 ! REQUIRED EQUIPMENT:
420 ! AA 5001 Programmable Distortion Analyzer.
430 ! SG 5010 Programmable 160 KHz Oscillator.
440 ! 4050A Series Controller
450 !
460 ! PROGRAM SEGMENT VARIABLES:
470 ! aaprim      AA 5001 primary address. Factory set to 28.
480 ! ssp1im     SG 5010 primary address. Factory set to 25.
490 ! nsteps     number of voltage steps.
500 ! amparay    array of programmed output levels.
510 ! thdaray    array of measured total harmonic distortion.
520 ! outaray    array of measured output.
530 ! testfreq   frequency at which Device Under Test is tested.
540 ! voltstrt   starting voltage of sweep.
550 ! voltstop   sweep stop voltage.
560 ! _toleran   tolerance for Delay Until Settled algorithm.
570 ! Counts     number of counts for DUS algorithm in AA 5001.
580 ! _points    number of readings to be within tolerance
590 !            and counts.
600 ! maxdist    maximum distortion allowed to define knee.
610 ! rload      load impedance of DUT.
620 !
630 ! OPERATING INSTRUCTIONS:
640 ! Connect output of SG 5010 to input of Device Under Test.
650 ! Connect output of DUT to input of AA 5001. Address of AA 5001
660 ! must be set to 28 and address of SG 5010 must be set to 25. If
670 ! addresses are different from these factory set addresses,
680 ! variables aaprim ( AA 5001 primary address ) and ssp1im
690 ! SG 5010 primary address ) must be changed accordingly.
700 !
710 ! ERRORS:
720 ! AA 5001 and SG 5010 addresses must be set to 28 and 25

```

Fig. 3-12. AA 5001 program example (4050A series).

```

730 ! respectively or program assignment of variables aaprim
740 ! and ssprim changed in program.
750 !
760 ! INSTRUMENT CONTROL:
770 ! Polls instruments on assigned addresses (AA 5001 and SG 5010).
780 !
790 ! *****
800 ! Begin main program segment
810 INIT
820 PAGE
830 Aaprim=28
840 Ssprim=25
850 Nsteps=21
860 DIM Amparay(Nsteps),Thdaray(Nsteps),Outaray(Nsteps)
870 Voltstrt=0.02
880 Voltstop=0.2
890 _toleran=0.1
900 Counts=1
910 _points=6
920 _maxdist=1
930 Testfreq=1000
940 Rload=100000
950 Title$="THD VERSUS OUTPUT POWER"
960 Xtitle$="Output Power in Watts"
970 Ytitle$="THD in Percent"
980 ON SKG THEN 2530
990 !
1000 ! Initialize Instruments
1010 WBYTE @Aaprim+32,Ssprim+32:73,78,73,-84
1020 WBYTE @95,63:
1030 ! Lock out the AA 5001 and the SG 5010 front panels.
1040 WBYTE @17:
1050 ! Set up AA 5001 for THD Function in percent, filters off, RMS.
1060 PRINT @Aaprim:"FUNC THDP;FILT OFF;RESP RMS"
1070 ! Set up AA 5001 to delay sending a readings until settled.
1080 ! Set tolerance, number of counts, and number of points.
1090 PRINT @Aaprim:"DUS ON;TOL ";_toleran;";COUNTS ";Counts
1100 PRINT @Aaprim:"POINTS ";_points
1110 ! Set up SG 5010 for test frequency, balanced output,
1120 ! out on, display volts RMS.
1130 PRINT @Ssprim:"FREQ ";Testfreq;";BAL ON;OUT ON;DISP VRMS"
1140 _stepsize=(LGT(Voltstop)-LGT(Voltstrt))/(Nsteps-1)
1150 PRINT @Ssprim:"VRMS ";Voltstrt
1160 Amparay(1)=Voltstrt
1170 !PRINT@AAPRIM:"FUNC VOLT;SEND"
1180 INPUT @Aaprim:Outaray(1)
1190 PRINT @Aaprim:"FUNC THDP;SEND"
1200 INPUT @Aaprim:Thdaray(1)
1210 Index=1
1220 FOR Count=LGT(Voltstrt)+_stepsize TO LGT(Voltstop) STEP _stepsize
1230 Index=Index+1
1240 PRINT @Ssprim:"VRMS ";10^Count
1250 Amparay(Index)=10^Count
1260 PRINT @Aaprim:"FUNC VOLT;SEND"
1270 INPUT @Aaprim:Outaray(Index)
1280 PRINT @Aaprim:"FUNC THDP;SEND"
1290 INPUT @Aaprim:Thdaray(Index)
1300 IF Thdaray(Index)=>_maxdist THEN 1340
1310 NEXT Count
1320 IF Index=>Nsteps THEN 1550
1330 !Resolve: Step back one step.
1340 IF Index<=2 THEN
1350 Voltstrt=Amparay(1)

```

Fig. 3-12 cont. AA 5001 program example (4050A series).

```

1360 ELSE
1370   Voltstrt=Amparay(Index-1)
1380 END IF
1390 Voltstop=Amparay(Index)
1400 Index=Index-1
1410 _remain=Nsteps-Index
1420 _stepsize=(LGT(Voltstop)-LGT(Voltstrt))/_remain
1430 FOR Count=LGT(Voltstrt)+_stepsize TO LGT(Voltstop) STEP _stepsize
1440   Index=Index+1
1450   PRINT @S$prim:"VRMS ";10^Count
1460   Amparay(Index)=10^Count
1470   PRINT @A$prim:"FUNC VOLT;SEND"
1480   INPUT @A$prim:Outaray(Index)
1490   PRINT @A$prim:"FUNC THDP;SEND"
1500   INPUT @A$prim:Thdaray(Index)
1510 NEXT Count
1520 Outaray=Outaray^2
1530 Outaray=Outaray/Rload
1540 !Finish: Test done.
1550 CALL Plotloop(Nsteps,Outaray,Thdaray,Title$,Xtitles$,Ytitles$)
1560 ! Unlock all instruments on the bus.
1570 CALL "RENOFF"
1580 CALL "RENON"
1590 OFF SRQ
1600 END
1610 SUB Plotloop(Nsteps,Outaray,Thdaray,Title$,Xtitles$,Ytitles$)
1620   PAGE
1630   WINDOW 0,130,0,100
1640   VIEWPORT 0,130,0,100
1650   PRINT "I      ";Title$
1660   PRINT "┌"
1670   FOR I=1 TO LEN(Ytitles$)
1680     S$=SEG(Ytitles$,I,1)
1690     PRINT USING 1700:S$
1700     IMAGE A/
1710   NEXT I
1720   MOVE 0,4
1730   PRINT "I      ";Xtitles$
1740   VIEWPORT 20,120,20,85
1750   Low=Thdaray(1)
1760   FOR Index=1 TO Nsteps
1770     IF Thdaray(Index)<Low THEN
1780       Low=Thdaray(Index)
1790     END IF
1800   NEXT Index
1810   High=Thdaray(1)
1820   FOR Index=1 TO Nsteps
1830     IF Thdaray(Index)>High THEN
1840       High=Thdaray(Index)
1850     END IF
1860   NEXT Index
1870   High=INT(10*High+1)/10
1880   Low=INT(10*Low-1)/10
1890   IF Low<=0 THEN
1900     Low=0
1910   END IF
1920   Dif=High-Low
1930   Lox=LGT(Outaray(1))
1940   FOR Index=1 TO Nsteps
1950     IF LGT(Outaray(Index))<Lox THEN
1960       Lox=LGT(Outaray(Index))
1970     END IF
1980   NEXT Index

```

Fig. 3-12 cont. AA 5001 program example (4050A series).

```

1990     Flas=0
2000     J=-1
2010     DO
2020         J=J-1
2030         IF Lox<J AND Lox=>J-1 THEN
2040             Lox=J-1
2050             Flas=1
2060         END IF
2070     EXIT IF Flas
2080     LOOP
2090     Decade=3
2100     WINDOW Lox*10,Lox*10+Decade*10,Loy,Hiy
2110     MOVE Lox*10,Hiy
2120     DRAW Lox*10,Loy
2130     DRAW Lox*10+Decade*10,Loy
2140     DRAW Lox*10+Decade*10,Hiy
2150     DRAW Lox*10,Hiy
2160     FOR P=Lox TO Lox+Decade-1
2170         FOR Q=2 TO 10
2180             T=10*LGT(Q*10^P)
2190             MOVE T,Loy
2200             FOR Tic=Loy TO Hiy STEP 0.1*Dif
2210                 RMOVE 0,-0.01*Dif
2220                 RDRAW 0,0.02*Dif
2230                 MOVE T,Tic
2240             NEXT Tic
2250         NEXT Q
2260         MOVE P*10-0.75,Loy-0.1*Dif
2270         PRINT "10"
2280         RMOVE 0.7,0.05*Dif
2290         PRINT P
2300         MOVE T,Loy
2310         DRAW T,Hiy
2320     NEXT P
2330     MOVE P*10-0.75,Loy-0.1*Dif
2340     PRINT "10"
2350     RMOVE 0.7,0.05*Dif
2360     PRINT P
2370     FOR Hor=Loy TO Hiy STEP 0.1*Dif
2380         MOVE Lox*10-4,Hor-0.01*Dif
2390         IF Hor=0 THEN 2420
2400         PRINT USING "2D.2D2A":Hor;"%"
2410         GO TO 2430
2420         PRINT USING "2A2D": " ";Hor
2430         MOVE Lox*10,Hor
2440         DRAW Lox*10+Decade*10,Hor
2450     NEXT Hor
2460     MOVE 10*LGT(Outaray(1)),Thdaray(1)
2470     FOR Count=2 TO Nsteps
2480         DRAW 10*LGT(Outaray(Count)),Thdaray(Count)
2490     NEXT Count
2500     HOME
2510     END SUB
2520     ! SRQ Handler
2530     DIM E$(60)
2540     Eflas=0
2550     POLL Addr,Stabyt,Asprim,SSprim
2560     GOSUB Addr OF 2580,2620
2570     GO TO 2940
2580     PRINT @Asprim:"ID?;ERR?"
2590     INPUT @Asprim:E$
2600     Addr=Asprim
2610     GO TO 2650

```

Fig. 3-12 cont. AA 5001 program example (4050A series).

```
2620 PRINT @S$prim:"ID?;ERR?"
2630 INPUT @S$prim:E$
2640 Addr=S$prim
2650 L=POS(E$,"ERR",1)
2660 Error$=SEG(E$,L,10)
2670 Error=VAL(Error$)
2680 S$=SEG(E$,8,6)
2690 IF S$="AA5001" AND Error=601 THEN
2700   Eflag=1
2710 END IF
2720 IF S$="AA5001" AND Error=701 THEN
2730   Eflag=2
2740 END IF
2750 IF S$="AA5001" AND Error=703 THEN
2760   Eflag=3
2770 END IF
2780 IF S$="AA5001" AND Error=704 THEN
2790   Eflag=4
2800 END IF
2810 IF Eflag=1 THEN
2820   E$=E$&"Display Overrange"
2830 END IF
2840 IF Eflag=2 THEN
2850   E$=E$&"Insufficient Input Level"
2860 END IF
2870 IF Eflag=3 THEN
2880   E$=E$&"Excessive Input Level"
2890 END IF
2900 IF Eflag=4 THEN
2910   E$=E$&"Unsettled Readings"
2920 END IF
2930 PRINT E$,"ADDRESS = ";Addr,"STATUS = ";Statst
2940 RETURN
2950 END
```

Fig. 3-12 cont. AA 5001 program example (4050A series).

```

100 ! *****
110 ! ***** TOTAL HARMONIC DISTORTION VERSUS OUTPUT POWER *****
120 ! *****
130 !
140 ! For 4041: July 22, 1983      Revised: September 28, 1983
150 !
160 ! Copyright (c) 1983 Tektronix, Inc. All rights reserved. This
170 ! software is provided on an "as is" basis without warranty of
180 ! any kind. It is not supported.
190 !
200 ! This program may be reproduced without prior permission, in whole
210 ! or in part, by the original purchaser. Copies must include the
220 ! above copyright and warranty notice.
230 !
240 ! PURPOSE:
250 ! Records the total harmonic distortion of a system to a logarithmically
260 ! increasing input signal at a frequency determined by variable testfreq.
270 ! The voltage is increased from the value of the variable voltstrt to
280 ! the value of the variable voltstop until the distortion is greater than
290 ! or equal to the value of the variable maxdist. When this point is
300 ! reached, the output of the SG 5010 is changed to the previous and a
310 ! new increment size is used. This technique allows the definition of
320 ! the knee of the curve. In order for the algorithm to produce useful
330 ! results, the value of variable voltstop must produce a distortion
340 ! equal to or slightly greater than the value of the variable maxdist.
350 ! The results are then printed out on the 4041 printer. The total number
360 ! of points is 21.
370 !
380 ! REQUIRED EQUIPMENT:
390 ! AA 5001 Programmable Distortion Analyzer.
400 ! SG 5010 Programmable 160 KHz Oscillator.
410 ! 4041 Controller (V2.0)
420 !
430 ! PROGRAM SEGMENT VARIABLES:
440 ! aaprim      AA 5001 primary address. Factory set to 28.
450 ! sspriim     SG 5010 primary address. Factory set to 25.
460 ! aa         AA 5001 logical unit number.
470 ! ss         SG 5010 logical unit number.
480 ! nsteps     number of voltage steps.
490 ! amparray   array of programmed output levels.
500 ! thdarray   array of measured total harmonic distortion.
510 ! outarray   array of measured output.
520 ! testfreq   frequency at which Device Under Test is tested.
530 ! voltstrt   starting voltage of sweep.
540 ! voltstop   sweep stop voltage.
550 ! toleran   tolerance for Delay Until Settled algorithm in AA 5001.
560 ! counts    number of counts for BUS algorithm in AA 5001.
570 ! points    number of readings to be within tolerance and points.
580 ! maxdist   maximum distortion allowed to define knee of curve.
590 ! rload     load impedance of DUT.
600 !
610 ! OPERATING INSTRUCTIONS:
620 ! Connect output of SG 5010 to input of Device Under Test.
630 ! Connect output of DUT to input of AA 5001. Address of AA 5001
640 ! must be set to 28 and address of SG 5010 must be set to 25. If
650 ! addresses are different from these factory set addresses, then
660 ! variables aaprim ( AA 5001 primary address ) and sspriim (SG 5010
670 ! primary address ) must be changed accordingly.
680 !
690 ! ERRORS:
700 ! No GPIB or tape error handlers are linked so 4041 prints default system
710 ! error messages and stops if such errors occur (instrument power is off
720 ! or tape capacity exceeded, etc.).

```

Fig. 3-13. AA 5001 program example (4041).





```

1360 Voltstop=amparay(index)
1370 Index=index-1
1380 Remain=nsteps-index
1390 Stepsize=(lst(voltstop)-lst(voltstrt))/(remain)
1400 For count=lst(voltstrt)+stepsize to lst(voltstop) step stepsize
1410   Index=index+1
1420   Print #ss:"VRMS";10^count
1430   Amparay(index)=10^count
1440   Input prompt "FUNC VOLT;SEND" #aa:outaray(index)
1450   Input prompt "FUNC THDP;SEND" #aa:thdaray(index)
1460   Next count
1470   Outaray=outaray^2/rload
1480 Finish: ! Test done.
1490 Out_data: call printout(nsteps,outaray,thdaray)
1500 ! Unlock all instruments on the bus.
1510 Wbyte ren(0),ren(1)
1520 End
1600 Sub printout(nsteps,outaray,thdaray) local count
1610 Print usins "FA4XFA" #2000:"OUTPUT POWER","THD"
1620 Print usins "20A" #2000:"-----"
1630 For count=1 to nsteps
1640   Print usins "7JA3X7.46A" #2000:outaray(count),"W",thdaray(count),"%"
1650   Next count
1660 Return
1670 End
1700 Sub handler local e$,stabyt,addr,eflas
1710 Dim e$ to 60
1720 Eflas=0
1730 Poll stabyt,addr
1740 Input prompt "ID?ERR?" #addr:e$
1750 If ses$(e$,8,6)="AA5001" and valc(e$,pos(e$,"ERR",1))=601 then eflas=1
1760 If ses$(e$,8,6)="AA5001" and valc(e$,pos(e$,"ERR",1))=701 then eflas=2
1770 If ses$(e$,8,6)="AA5001" and valc(e$,pos(e$,"ERR",1))=703 then eflas=3
1780 If ses$(e$,8,6)="AA5001" and valc(e$,pos(e$,"ERR",1))=704 then eflas=4
1790 If eflas=1 then e$=e$&"Display Overranse"
1800 If eflas=2 then e$=e$&"Insufficient Input Level"
1810 If eflas=3 then e$=e$&"Excessive Input Level"
1820 If eflas=4 then e$=e$&"Unsettled Readins"
1830 Print usins "FAL=FA2DL=FA3DL" #2000:e$,"ADDRESS = ",addr,"STATUS = ",stabyt
1840 Resume
1850 End

```

Fig. 3-13 cont. AA 5001 program example (4041).

## **WARNING**

THE FOLLOWING SERVICING INSTRUCTIONS ARE FOR USE BY QUALIFIED PERSONNEL ONLY. TO AVOID PERSONAL INJURY, DO NOT PERFORM ANY SERVICING OTHER THAN THAT CONTAINED IN OPERATING INSTRUCTIONS UNLESS YOU ARE QUALIFIED TO DO SO. REFER TO OPERATORS SAFETY SUMMARY AND SERVICE SAFETY SUMMARY PRIOR TO PERFORMING ANY SERVICE.



**SECTION 4**  
**THEORY OF OPERATION**

**Introduction**

Refer to the block diagram located in the foldout pages of this manual for a brief description and overall view of the AA 5001 operation. A detailed circuit description follows.

**Input Amplifier**



The input amplifier is designed for low noise and distortion. The input configuration is differential with single-ended output. This circuit provides good common mode rejection for suppression of ground loop currents and other unwanted signals which may be present on both input leads. The input stage is also protected to withstand at least 200 V rms on any input range.

The input amplifier gain is set by the logic circuitry at 0 dB (unity), +10 dB or +20 dB. The logic circuitry controls the gain so that the signal voltage at the output of the amplifier remains between 0.75 V and 3.0 V rms. An attenuator, prior to the amplifier, provides additional gain settings from -10 dB to -40 dB in 10 dB steps. The actual gain or attenuation selected depends on the input voltage level (or the setting of the INPUT RANGE switch if not in AUTO RANGE). For example, the 200 V Input Range corresponds to 40 dB of attenuation and amplifier unity gain.

The input signal, from the front panel connections or the rear interface input (selected by front panel switch S6181) enters the input amplifier through P4070/J4070. Each input is ac coupled through C6070 or C4070. The signal then passes to the differential input attenuator hybrid, R2052. These resistors are laser trimmed and ratioed to maintain gain accuracy and common mode rejection. Relays K2052, K2060, K2061, K2070 and K2071 select attenuation from 10 dB steps. Frequency compensation of the attenuator is provided by C2061, C2051, and R2051.

When there is no attenuation (0 dB), DS3050 and DS3060 limit the input current under overload conditions. The current passing through the lamps warms their filaments, increasing their resistance. These lamps will sustain 120 Vac indefinitely and 200 Vac for at least 30 minutes. If the AA 5001 is subjected to greater overloads in the 0 dB attenuator position, the lamps act as fuses. When any attenuation other than 0 dB is selected, the resistance in the hybrid network provides current limiting. The inputs are clamped by Zener diodes VR4071 and VR4070 through four diode connected transistors Q4060, Q4061, Q4070 and Q4071 and four diodes CR 4072 through CR 4075. When the post attenuator voltage on any scale exceeds about 10 V, one set of transistors turns on to limit the voltage at diode connected U4050A and B. The effect of the nonlinear capacitance of clamp diodes CR4072, CR4073, CR4074 and CR4075 is eliminated by maintaining a constant voltage across the diodes via a bootstrap arrangement from the outputs of U4050A and B.

The input signal is buffered by low noise amplifiers U4050A and U4050B. On the 0 dB through 40 dB attenuation ranges, these buffers provide unity gain. Relays K2050 and K2051 change the gain to +20 dB or +10 dB, respectively, by adding resistors R4056D or R4056E. Capacitors C4053 and C4062 provide frequency compensation.

The buffer outputs are combined into a single-ended output signal by U4061 (gain=1.5). This signal is then routed to the automatic gain control circuitry (agc) and input amplifier level detector.

The gains of the combining stage and the buffers are controlled by hybrid resistor R4056. These resistors are laser trimmed and ratioed to insure gain accuracy and common mode rejection.

The signal level at the output of the input amplifier is detected by active rectifier U4041, in conjunction with CR4041 and CR4042. This full wave rectified signal is filtered by U4042A with C3045 and routed to the logic circuitry through J1060, pin 1. Recovery from overload is provided by VR3041. Resistor R4040 sets the filter gain so that, with 2 V rms into the AA 5001 input on the 2 V scale (3 V at pin 6 of U4061) the output at pin 1 of U4042 is 6 Vdc.

The gain setting driver relays, K2052 through K2071, are driven by the inverting amplifiers within U1060. Control signals from the logic circuitry enter the input board through P1060-J1060, pins 2 through 9, with one line at a time high (about +12 V). This logic high causes a low at the output of the inverting amplifier and closes the relay. When either 0 dB, +10 dB or +20 dB (pins 6, 7 or 8) is activated, K2052 activates directly or by Q1070 and U1050B. In AUTORANGE, the logic circuitry selects the proper input attenuation or gain to maintain 0.75 V to 3.0 V at U4061 pin 6 for inputs greater than approximately 50 mV.

**Automatic Gain Control**

2

The output of the input amplifier feeds the agc circuitry at levels between 0.75 V and 3.0 V for inputs greater than approximately 50 mV, and the agc automatically adjusts the signal to a constant 1.61 Vac. This is the reference level for the distortion measuring circuits.

The agc circuitry is composed of attenuator R4053, U5041, U5051, R4055, and amplifier U4051. The control element in the agc is a pair of light-dependent resistors (LDRs), U5041 and U5051. These devices consist of a light emitting diode and a semiconductor resistance cell in one package. As more control current is forced through the LEDs, the cells are illuminated more brightly and their cells resistance decreases. This causes more signal to shunt to ground.

The control circuitry for the agc consists of active rectifier, U4042B with diodes CR4052 and CR4051. The filters are composed of U4062A and U4062B and associated components. This circuitry seeks to keep the voltage at the output, pin 6 of low noise operational amplifier U4051, to approximately 1.61 V. This output voltage is varied to calibrate the THD measurements by adjusting R1051, the THD CAL control.

The output of U4051 is fullwave rectified by U4042B with diodes CR4051, CR4052 and integrated by U4062A and C5061 with the reference current from R5041 and R4042. Amplifier U4062B in conjunction with C5060, C5062, R5063, R5064 and C5063 with R5065 provides additional filtering of the rectified voltage to reduce distortion introduced by the agc action. Transistor Q5071 provides the current drive necessary for the LDRs, while VR5051 linearizes the open loop gain of the agc loop to optimize transient response at all signal amplitudes.



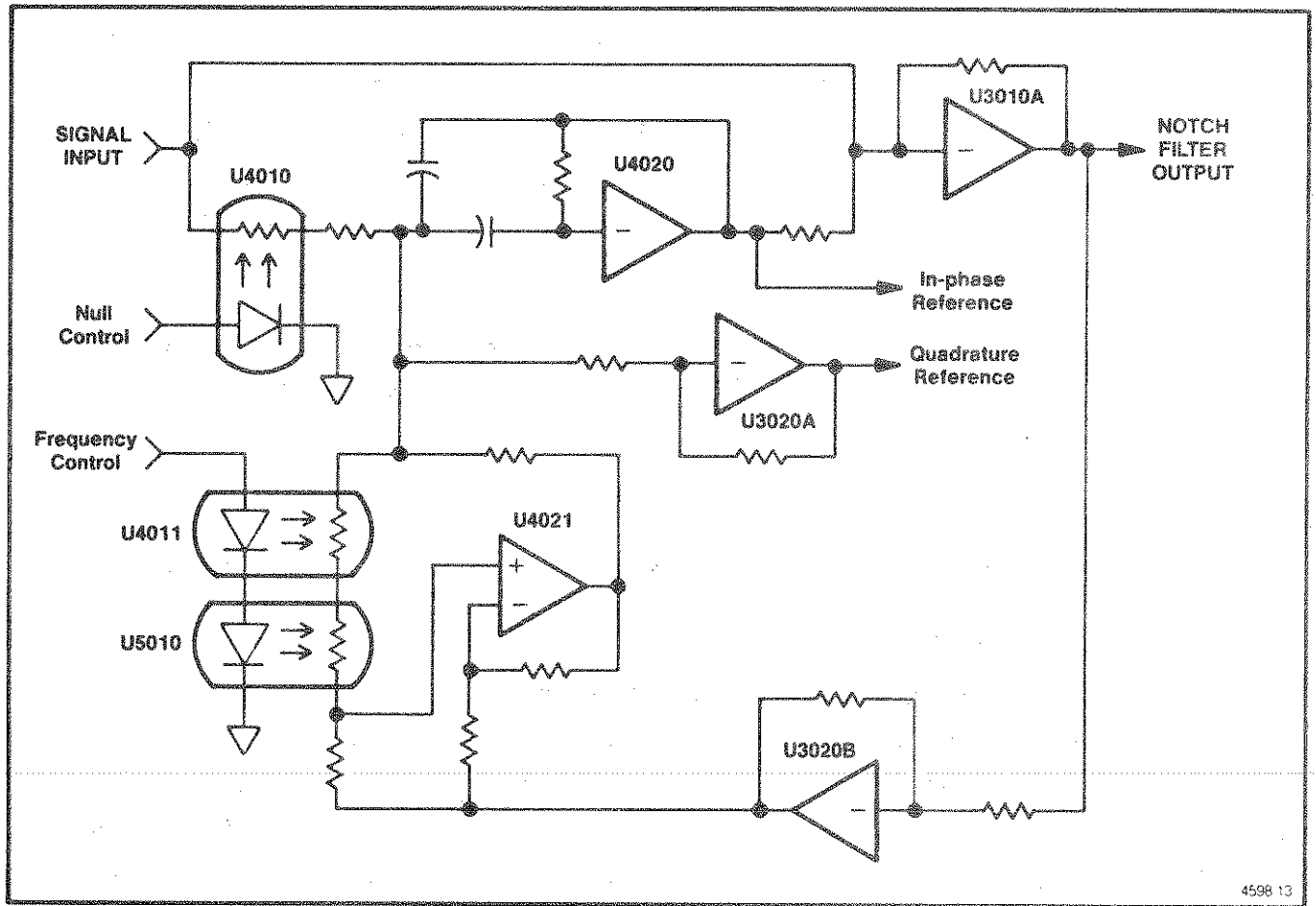

Fig. 4-1. Simplified notch filter.

### Notch Filter

2

The leveled output from the agc (U4051) provides the input for the notch filter. The notch is formed by summing the output of an inverting band pass filter with the input signal. See Fig. 4-1. Operational amplifier U4020, and associated resistors and capacitors comprises a multiple feedback path inverting band pass filter. Amplifier U3010A is an inverting summer. Filter tuning is accomplished in half decade bands by switching both resistors and capacitors. Capacitors are switched each decade. Relay K4031 is energized for input frequencies below approximately 10 kHz. When below approximately 1 kHz, K4032 is also activated, while below approximately 100 Hz, K5030, K4032, and K4031 are used. K4030 is energized in the upper half of each decade

reducing the tuning resistances by a factor of 3.2 thus scaling up the frequency range by a factor of 3.2. Continuous tuning within each half decade is achieved by adjusting the impedance of an electronic resistor (U4021A and B) with LDR opto isolators U4011 and U5010. As the LDR resistance rises, the electronic resistor value decreases, at the junctions of the outputs of R3026 and R5033, raising the filter frequency.

This circuit technique, although unusual, provides a good compromise between residual noise and distortion sources inherent in U4021, and LDR's U4011 and U5010.

U3020B feeds back a portion of the notch output to the electronic resistor keeping the Q of the bandpass filter nearly constant, as it is tuned.

Minor variations in the gain of the band pass filter (which causes incomplete cancellation of the fundamental) are compensated by a third LDR, U4010. Components C4021, R5032 and C5031 provide additional gain compensation. Drive signals for the LDRs come from the control loop circuitry. Synchronization signals, to run the control loops, come from the outputs of U4020 and U3020A.

**Frequency Band Discriminator**

5

The signal from the junction of R2026 and R3021 located on schematic 2 is squared by a Schmitt trigger, composed of Q1041 and Q1042. The frequency band is determined by measuring the period of the resulting squarewave. When the input goes high, the outputs of U2050 change state. Assuming the Q outputs are high, the capacitors in the four rc networks (that are connected to the Q outputs of U2050) start to charge. The capacitor voltage on each network is compared via U2051 to a reference voltage developed across R2065, R3060, and R3061. When the input signal again goes high, the outputs of the comparators are latched in U2042. Simultaneously, the outputs of U2050 go low to discharge the capacitors in the rc networks in preparation for the next cycle.

If the period of the input is more than half the RC time constant, the capacitor voltage will be above the threshold and the comparator output is high at the transition. See Fig. 4-2. Discrimination of half decades is obtained by selecting the appropriate RC network via a CMOS switch (U2060) and comparing it to a higher reference voltage at pin 6 of U2051B. The last column in Table 4-1 shows the inputs for U2060. If the input frequency is below the band switch point of the selected decade (about 2.8 kHz for the 1 kHz to 10 kHz band) the output of U2051 is low. Resistors R2054, R3052, R2052, and R2050 provide a slight hysteresis at each decade edge, while R1515 provides hysteresis at half decade points. This hysteresis prevents random band switching when measuring signals close to the transition frequencies.

A bounce eliminator, U2041, prevents random band changes caused by grossly non-periodic signals. Capacitor C1041 sets the internal clock frequency of U2041 to approximately 100 Hz. The input state to U1400 must be stable for four clock cycles or 0.04 seconds for any change in output to occur.

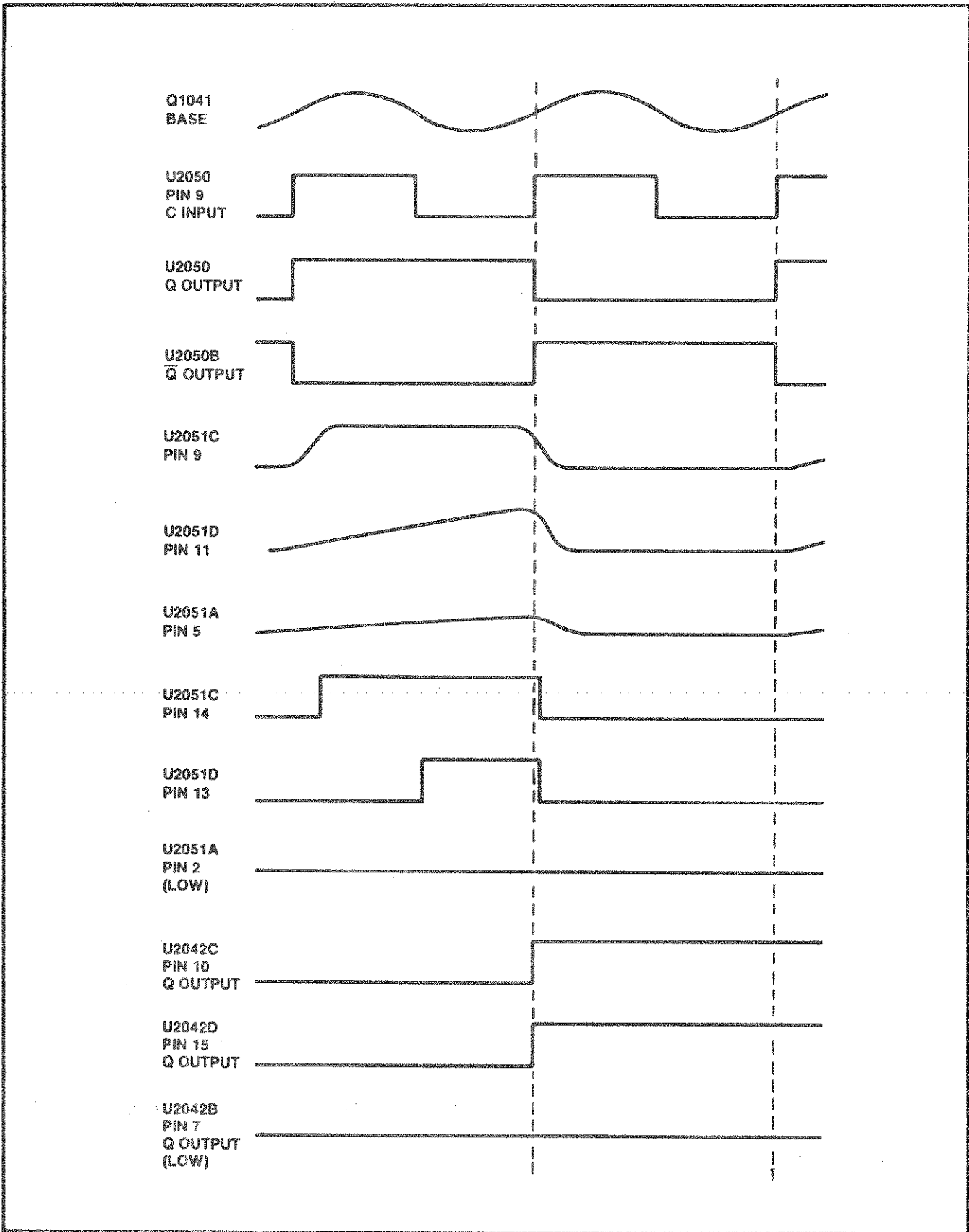

Fig. 4-2. Frequency band discriminator

**Table 4-1**  
**TRUTH TABLE FOR U2042 OUTPUTS**

| Fin (Hz)  | Q<br>U2042A<br>pin 3 | Q<br>U2042C<br>pin 10 | Q<br>U2042D<br>pin 15 | Q<br>U2042B<br>pin 7 | U2060<br>input<br>pin no. |
|-----------|----------------------|-----------------------|-----------------------|----------------------|---------------------------|
| 10-28     | L                    | H                     | H                     | H                    | 4                         |
| 28-95     | H                    | H                     | H                     | H                    | 4                         |
| 95-280    | L                    | H                     | H                     | L                    | 12                        |
| 280-950   | H                    | H                     | H                     | L                    | 12                        |
| 950-2.8k  | L                    | H                     | L                     | L                    | 14                        |
| 2.8k-9.5k | H                    | H                     | L                     | L                    | 14                        |
| 9.5k-28k  | L                    | L                     | L                     | L                    | 13                        |
| 28k-100k  | H                    | L                     | L                     | L                    | 13                        |

#### Notch Filter Control



The notch filter is controlled by demodulating the in-phase and quadrature phase (shifted 90 degrees) components of the notch filter output referenced to the input fundamental signal. See Fig. 4-1. The in-phase reference inputs to pin 2 of U1020A, and the quadrature phase reference inputs to pin 6 of U1020B. When the notch frequency is correctly tuned, there is no quadrature phase component at the notch filter output. When the fundamental null (maximum amplitude rejection) is adjusted correctly, there is no in-phase component in the notch filter output.

The notch filter output is amplified by U3010B and U1011B. A total of 50 dB of gain is provided by these amplifiers. Differential input to the demodulators (U1010) is provided by U1011A. The output of this amplifier stage is rectified by CR1010 and CR1011. This signal is amplified by Q2010 and filtered by C2011 to control the resistance of FET Q2011, thus providing automatic gain control. This loop serves to

optimize and level the input to the demodulators that generate the tuning and nulling error voltages. The amplifier gain is raised by Q2012 in all but the lowest fundamental frequency decade.

As stated earlier, the in-phase component of the fundamental derived from the output of the bandpass filter U4020 (located on diagram 2) feeds pin 2 of U1020A. This circuitry forms a CMOS compatible logic signal to drive the CMOS multiplexer, U1010. The quadrature component of the fundamental derived from U3020A (diagram 2) similarly feeds pin 6 of U1010B. The switching arrangements of U2020 are shown in Table 4-2. The input to U2020A is switched between the inverted (pins 1 and 13) and the normal (pins 2 and 12) output of the notched filter at rate and phase determined by the in-phase signal at pin 10. The input to U2020B is also switched between the normal and inverted inputs to U1010 at a rate and phase determined by the quadrature signal at pin 11. The outputs of U1010 represent the synchronously demodulated in-phase and quadrature components of the fundamental, present in the notch output signal.

These outputs are integrated by U2020A, for the amplitude control loop and U2020B for the frequency control loop, buffered by Q2021 and Q2024, to drive the respective LDR opto-isolators in the notch filter. The net dc polarity of the signals at pins 15 and 14 determine, after passing through integrators U2020A and U2020B, the direction of frequency change and amplitude change necessary to properly set the notch frequency and null the fundamental. Adjustments R1023 and R1031 trim out the effects of offsets in the operational amplifiers enabling adjustment of the loops for best nulling of the fundamental frequency. When stabilized, the dc signal at pins 14 and 15 of U1010 is essentially 0 V.

The gain of the frequency control integrator is increased by Q2023 in all but the lowest frequency decade. Components VR2022, VR2023, R2018, C2010, CR2024, and CR2025 help speed the frequency control integrator for large control errors. VR 4010 linearizes the open loop gain of the frequency control loop.

**Table 4-2**  
**INTERNAL CONNECTIONS IN U1010 DEPENDINGS8**  
**ON LOGIC STATES OF PINS 10 AND 11**

| Logic<br>Level<br>Pins<br>11 10 | Internal Connections<br>Pins |
|---------------------------------|------------------------------|
| 0 0                             | 12 to 14 & 2 to 15           |
| 1 0                             | 13 to 14 & 2 to 15           |
| 0 1                             | 12 to 14 & 1 to 15           |
| 1 1                             | 13 to 14 & 1 to 15           |

#### Distortion Amplifier



This circuitry amplifies the distortion components from the THD notch filter or the IMD section, as well as providing additional gain for the three lowest input ranges in level function.

Multiplexer U2040, selects the input source for the distortion amplifier. The four sources are: input stage pins 5 and 15, input stage less 10 dB pins 1 and 13 (through R2033 and R2032), THD notch filter pins 2 and 4, and IMD pins 12 and 15. Control of U2040 is through the level and IMD switches, as well as the output of U3021A as shown on the schematic. In the IMD mode, Q2042 turns on. This action shorts the THD input to U2040 to prevent possible crosstalk. In both the THD and IMD, Q2041 also turns off, to prevent crosstalk.

The distortion amplifier gain is controlled by multiplexer U2031. The input to U2030B, attenuated by R2036, R2037 or R2041 is supplied from U2031. See Table 4-3. A gain of +46 dB is provided by U2030A and B. The output of U2030A supplies a 4 V rms full scale signal to the filters.

Table 4-3  
GAIN AND SWITCHING THROUGH U2031

| Logic Level Pins<br>9 10 | Total Gain through Dist Amp | U2041 Gain | Internal Connections pins |
|--------------------------|-----------------------------|------------|---------------------------|
| 0 0                      | +6 dB                       | 0 dB       | 13 to 12 and 3 to 1       |
| 0 1                      | +26 dB                      | 0 dB       | 13 to 14 and 3 to 5       |
| 1 0                      | +46 dB                      | 0 dB       | 13 to 15 and 3 to 2       |
| 1 1                      | +66 dB                      | +20 dB     | 13 to 11 and 3 to 4       |

#### Filters and Ac-Dc Converters (Standard Instruments Only)

6

The output of the distortion amplifier enters the main board through J1042 driving the weighting filters and the distortion amplifier ranging level detector. The detector, composed of U4030A and U4030B, full wave rectifies and filters the distortion amplifier output. This dc signal goes to the logic board to control auto-ranging of the distortion amplifier.

The weighting filters consist of U2023A, U2023B, U3021B, U3021A and associated resistors and capacitors. The signal from the distortion amplifier passes through the 330 kHz filter before passing to the remaining filters. Output from the filters is multiplexed by U1021 to the input of buffer, U4020A. Table 4-4 is a truth table for U1021.



**Table 4-4**  
**TRUTH TABLE FOR U1021**

| B | A | ON CHANNELS |    |                 |
|---|---|-------------|----|-----------------|
| 0 | 0 | X0          | Y0 | WEIGHTING       |
| 0 | 1 | X1          | Y1 | BANDPASS        |
| 1 | 0 | X2          | Y2 | 80 kHz LOWPASS  |
| 1 | 1 | X3          | Y3 | 330 kHz LOWPASS |

The highpass filter (three pole 400 Hz Butterworth) is composed of U4020B, C4012, C4011, C4010, R4012, R4010, and R4011. This filter is driven by U4020A. When the highpass filter is disabled, U3020 connects pins 1, 13, 14, and 15 thus shorting the output of U4020A directly to the input of U4020B. R4013, R4014, and C4013 provide 10 Hz response compensation for low frequency accuracy.

Output from the highpass filter, U4020B, connects to the front panel Function output connector and the Cy channel of U3020. The AUXILIARY INPUT on the front panel connects to the Cx input through protection components R3022, CR4020, and CR4021. U2030B connects to either the AUXILIARY INPUT or the output from U4020B depending upon the state of the EXT control signal.

After filtering, the signal is converted to a dc voltage by both rms and average techniques. Rms conversion is accomplished in U3031 (pin 10 out) using an implicit computing approach. The averaging capacitor is C3032. A low pass filter, U2040A, reduces readout jitter due to low frequency noise or ripple.

The averaging rectifier is U2030A with diodes CR2031 and CR2032. The rectified output is smoothed and filtered by U2040B, C1040, and associated components. The average detector output connects to U2040A via Q3040 in the average response mode, overriding the rms converter.

**Filters and AC-DC Converters (option 02 Instruments Only) 6a**

The output of the distortion amplifier enters the main board through J1042 to drive the filters and the distortion amplifier ranging level detector. This detector, composed of U4030A and U4030B, full wave rectifies and filters the distortion amplifier output. This dc signal goes to the logic board to control the distortion amplifier autoranging.

The filters consist of U2023A, U2023B, U2021B, U2040A, U2040C, and U2040D with associated resistors and capacitors. The signal from the distortion amplifier passes through the 330 kHz filter before passing to the 80 kHz LO PASS and AUDIO BAND PASS filters. The weighting filter input is taken directly from the distortion amplifier output. R2035 provides gain calibration adjustment for the CCIR weighting filter. Output from the filters are multiplexed by U1021 to the input of buffer U4020A. Table 4-4 is a truth table for U1021.

The high pass filter (three pole 400 Hz Butterworth) is composed of U4020B, C4012, C4011, C4010, R4012, R4010, and R4011. This filter is driven by U4020A. When the high pass filter is disabled, U3020 connects pins 1, 13, 14, and 15, shorting the output of U4020B directly to the input of U4020B. Components R4013, R4014, and C4013 provide 10 Hz response compensation for low frequency accuracy.

Output from the high pass filter, U4020B connects to the front panel FUNCTION OUTPUT connector and the Cy channel of U3020. The AUXILIARY INPUT, on the front panel, connects to the Cx input through protecting components R3022, CR4020, and CR4021. U2030B connects to either the AUXILIARY INPUT or the output from U4020B, depending upon the state of the EXT control signal.

After filtering, the signal is converted to a dc voltage by both rms and quasi-peak techniques. Rms conversion is accomplished in U3031 (pin 10 out) using an implicit computing approach. The averaging capacitor is C3032. A low pass filter, U2021A, reduces readout jitter due to low frequency noise or ripple.

The quasi-peak convertor consists of full wave rectifier U2040B, peak detector U4031 and U3030A, and averager U3030B and their related circuitry. The input to the full wave rectifier is normally connected through R2022, except for the special case of simultaneous CCIR weighting filter and quasi-peak response selections. In this case, Q2021 turns on directly connecting the output of the CCIR weighting filter from U2040A to the full wave rectifier. This causes a gain calibration shift of the weighting filter, depending upon the response selection. With RMS response, the 0dB frequency is nominally 2.0 kHz. However, with quasi-peak response, it shifts to 1.0 kHz.

The output from the full wave rectifier, U2040B, passes to pin 2 of U4031. This circuitry rapidly charges C3053 to the peak value of the input waveform. This peak voltage is referenced to the input through U3030A with R4055, providing gain calibration adjustment. U3030B, C3052, and R3033 low-pass filter the charged peaks on C3053 and pass the signal on to the peak hold circuit, composed of U3030D and U3030C.

The purpose of the peak hold circuit is to allow short peak pulses to be accurately measured and displayed on the digital readout. Capacitor C3038 is charged to positive peaks through CR4033 until U3030D inputs at pins 12 and 13 are nearly equal. C4031 is also charged through CR4034. When the peak disappears, CR4033 reverse biases, and C3038 maintains the peak voltage which is buffered through U3030C and connected to the convertor output through Q3040 and U2021A. The voltage across C4031 decays through R4035 generating approximately 1 second time delay. The voltage across C3038 remains constant until the voltage across C4031 drops to about 7 V below the level on C3038. C3038 then discharges through Q4030, operating as a low leakage zener diode. The quasi-peak detector output connects to U2021A via Q3040, in the quasi-peak response mode, overriding the rms converter.

## dB Converter



The dB section is fed by the dc output voltage from the selected detector. Shown on this schematic are the dB converter, dB/Volts switch, offset generator, dB ratio circuit, and a voltage reference.

The dB converter consists of quad operational amplifier U4111, transistor array U5101 and associated circuitry. The input to the converter is a 0-4 V dc signal from the selected detector and a 6 V reference. The output is a dc signal at U4111 pin 1. This signal is proportional to the log of the ratio of the dc input signal to the reference voltage as described in the relationship:

$$E = K \times \log\left[\frac{I_{c \text{ for } U5101A}}{I_{c \text{ for } U5101B}}\right]$$

K is a constant and  $I_c$  is the noted collector current. The converter output is zero when the input voltage is 1.549 V, with a scale factor of -100 mV/dB.

Operational amplifier U4111D provides a constant collector current in U5101B while holding the collector voltage at 0. The collector voltage of U5101A is held at 0 V by the action of U4111C. The collector current in U5101A varies with the input voltage. When the two collector currents are equal (at  $V_{in} = 1.549$  Volts), U5101A pin 2 is at 0 V and U4111C pin 8 is at 0 V. The offset voltage of the differential pair and U4111A is adjusted by R8101 (0dB adjust), which sets the 0 dB output level. Compensation for the offset voltage of U4111C (-40dB Adjust) is provided by R8091. This provides correct log conformity at low input voltages. Inversion of the dB output is provided by U4111A. Pin 1 of U4111A also provides the dB voltage to the bar graph display.

The three remaining transistors in U5101 serve as heaters to maintain the differential pair (U5101A and B) at a constant junction temperature. The voltage at U5101 pin 3 is proportional to the internal temperature of U5101. This voltage is compared with the reference voltage and any error is amplified by U4111B. The amplified error signal drives Q3111 which supplies current to the heater transistors. The

-20 dB Adjust, R2161, sets the internal junction temperature of the differential pair for the correct scale factor.

### dB Offset Generator

The offset generator consists of U4121, U7101 and R7101. This circuitry provides a dc offset voltage that is added to the log converter output at the input of operational amplifier U4121C. This voltage is set by input from the logic section and corrects dB measurements for the overall gain in the signal path.

The reference voltage is divided by R7101 into six offset voltages. Multiplexer U7101 selects one of these six voltages (or ground) and supplies it to U4121D. The gain setting resistor for U4121D, as well as a resistor in series with its output, is included in R7101. The offset output is supplied to U4121C through R8111.

This signal is routed to U2151, a multiplexer, which selects the dB-processed voltage (+10 mV/dB) or the voltage directly from the selected detector. This voltage is supplied to the DVM section. In the distortion modes, R3173 provides a small offset so that the 0 dB reference is changed from 0.775 V (0 dBm) to 1 V corresponding to 100%. In the dB ratio mode, U4121C also adds the stored reference voltage from the dB<sub>r</sub> section supplied via pin 5 of U2151.

### dB Ratio Circuitry

The dB ratio circuitry allows selection of any input voltage as the 0 dB reference. This is accomplished by adding a dc offset voltage from pin 15 of R7121 to pin 9 of U4121 through multiplexer U2151C. This causes 0 V at pin 8 of U4121C at the desired reference input voltage.

Amplifiers U6121C and D with resistor network R7121 form a digital-to-analog converter which supplies the dc offset to the input of U4121C. This converter is driven by an 11 bit binary counter composed of U6111 and U7111. This counter is controlled by dual flip-flop U7161B which is supplied with a clock signal from the gated oscillator composed of U7151A and B.

When the dB ratio button is pushed (grounded) a debounce circuit composed of U7151C and D causes pin 3 of U7161A to go high. A short time later, determined by R8131 and C8135, pin 4 of U7161A goes high, terminating the high at pin 1. A positive pulse appears at U7161 pin 1, resetting counters U6111 and U7111 and flip-flop U7161B. This allows the oscillator to start. The oscillator increments the counters changing the voltage offset. When the 0 dB reference button is pushed, the counter starts with the most negative voltage offset and increments in the positive direction. The output of U4121C connects to comparator U6121B. When the output of U4121C is 0 V, U6121B pin 7 goes high, causing U7161B pin 12 to go low at the next clock pulse. This action stops the oscillator. Future dB readings are referenced to this voltage. Pin 1 of U6121A goes positive a short time before U6121B pin 7. This switches the oscillator to a lower frequency through Q8161 and C7135 to prevent the circuits from overshooting the correct value.

## 6 V Reference 7

A 6 V reference voltage to the dB converter, offset generator, dB section, and dvm is provided by U4121A and VR2143.

## DVM 8

The DVM section accepts the dc voltage from the dB converter or directly from the ac selected to dc converter and drives the digital display. The dvm input is proportional to the input signal voltage, the percent distortion or the log (dB) of the selected function. An LSI analog-to-digital converter with display drivers, U2050, drives the respective segments in LED display. Overrange indication is supplied internally in U2050. Reference voltage adjustment for the correct full scale reading is provided by R2064. Other external components support the internal operation of U2050.

The most significant LED module, DS1022, is controlled by U1060D and Q1060. This digit displays blank, 1 or 0. The 0 is displayed only in the 0.2% distortion range.

If a decimal point is needed in LED display DS1021, pin 2 of U1060A is low. This assures that pin 11 of U1060D is also low and illuminates the two segments comprising the one (1) in the most significant digit module, DS1022. Pin 19 of U2050 is high when a 0 is required and low when a 1 is required. The one is changed to a zero by illuminating an additional four segments of DS1022. The minus sign to the left of the most significant digit 15 of R1333 to pin 9 of U1313C. This causes 0 V at pin 8 of U1313C at the desired reference input voltage.

The ten operational amplifiers, U3050A, B, U3051 and U3062 comprise the drivers for the bar graph display. The analog signal from the dB converter is applied to the negative inputs of these amplifiers. The input resistance dividers are selected so that only one operational amplifier at a time is operating in the linear region. There is approximately 2.5 dB between each segment, with a slight overlap from one segment to the next.

#### Display Board

The four LED digit display modules and the sign module are illuminated by lowering the cathode voltages. The display module anodes and the state LEDs are operated from +5 V.

Pins 11 through 20 of DS1010, the bar graph display, are connected to -15 V. Pins 1 through 10 are driven by operational amplifiers in conformance with the analog signal strength.

#### Logic Circuitry

The input signals to the logic section come from the front panel switches, the input stage level detector, GPIB circuitry and the distortion amplifier level detector. The logic circuitry controls the gain of the input stage and distortion amplifier, the dB offset generator, location of the decimal points and the function annunciator LEDs.

Diagram 10 shows the logic switching circuitry.

On diagram 11 a presettable up-down counter, U7011, controls the gain of the input stage. In the manual ranges, the preset inputs are enabled by S4171-4. The proper input level range signals are supplied by S4171-1, 2, and 3. In the auto range position, the counter accepts clock inputs from level comparators U5081A and B. These signals pass from U7011 to U3011. They are decoded in U3011, a bcd-to-decimal decoder, to drive the input stage gain control lines.

A dc signal, proportional to the input signal amplitude, appears at pin 4 of U5081A. The bias voltages on pins 5 and 6 of U5081A and B are such that pin 2 of U5081A goes low when the input signal is higher than the range the input stage is presently in. This low appears at pin 10 of U7011 which causes the binary up-down counter to count down. If the input attenuator is in the least sensitive range, a high exists on pin 1 of U7021A. A low then exists on pin 3 of U7021A which prevents the underrange LED from being illuminated. Pin 1 of U5081B is low when the input signal is lower than the input attenuator range. Pin 6 of U7021B is high in the most sensitive range. The up-down counter counts only when pin 5 is low. This occurs when the input signal level is higher than the attenuator range and the unit is not in the least sensitive position, or when the input signal is lower than the input attenuator range and the unit is not in the most sensitive range. The overrange and underrange LEDs are illuminated through Q2181 and Q2183 respectively. When the bases of these transistors are high, through the outputs of U7021A and U7021B, the lights are illuminated. The increase range and decrease range lights are also controlled by the distortion amplifier gain in the level mode.

U3021 decodes the odd 10 dB steps in the input stage gain and supplies this information to the distortion amplifier control and to U5011 for decimal point and offset formatting purposes.

Distortion amplifier gain is controlled in a manner similar to the input circuitry gain. U5081C, and U5081D are the level comparator and U7071A, U7071B, and U7071D perform the enable gating function.



The gain control input for the distortion amplifier is selected by U7041, a 4 bit and/or selector. In the level mode pin 9 is high, pin 14 is low, and pins 6, 4, and 2 are routed to the outputs. This selects the Input Level Range Switch, S4171, as the gain control input. In the distortion modes, pin 14 is high, 9 is low and 7, 5, and 3 are connected to the output. The distortion range switches now control the gain.

The signals from and to U7021C control the switching of U7041. A dc voltage proportional to the output of the distortion amplifier connects to pin 11 of U5081D. The operation of U5081 and U7071 are identical as described for the input stage up/down counter. These gates control up/down counter, U7061, for the distortion amplifier gain. A three-to-eight decoder driver, U5071, supplies decimal output for the distortion amplifier gain control circuitry.

A binary adder, U5011, shown on schematic 12, sums the gain of the input stage and the distortion amplifier. Pins 7, 5, 3 and 6 provide input stage gain information. Pins 4 and 2 provide distortion amplifier gain information. This sum is decoded by U5021, and passes through CR5031, CR5033 and CR5037. These diodes drive U3021B and U4061 to operate the uV, mV, and Volts annunciator LEDs. The control source for the decimal points is selected by U3041, a 4 bit and/or selector which operates as a multiplexer. In the volts mode, the decimal points are controlled by the decoded decimal information from U5021 and the diodes. In the distortion modes, the decimal points are controlled by the distortion amplifier gain. Gain information from the distortion amplifier appears at 1, 3, 5 and 7. In the dB modes, U3041 is disabled, and Q2063 is turned on by U4071A or U4071B. This illuminates the proper decimal point for all dB displays.

A 4 bit and/or selector (U5061) operating as a multiplexer, selects the control source for the dB offset generator. In the lever mode, the offset is controlled by the sum at the output of U5011. In the distortion modes U5061 is controlled by the distortion amplifier gain.

**Power Supplies**

13

There are three operating voltages in the AA 5001: + and -15 V dc and +5 V dc. The 15 V supplies the operational amplifiers, linear circuitry and CMOS, while +5 V is used for the logic and display circuitry.

The +5 V dc supply is derived from the +8 V dc supply in the mainframe. A three terminal voltage regulator, U4040, provides +5 V and includes built-in current limiting. Additional overcurrent protection is provided by F4062. R3047 provides adjustment of the voltage to a nominal value of +5.25 V measured at TP3041.

The +15 V dc supply is regulated from the +26 V dc mainframe supply. The reference voltage, against which the regulator output, divided down by R3043 and R3044 is compared, is supplied by VR3041. Errors between the reference voltage and divided output are amplified by U4041B and Q4050. The mainframe NPN transistor and Q3051 form a Darlington series-pass transistor. Frequency compensation for stability is provided by R4050 and C4050. Current limiting is accomplished by Q3050 which senses the voltage across R3053. When the current delivered by the +15 volt supply exceeds about 500 mA, Q3050 turns on. This shunts base drive current from Q3051 lowering the output voltage. Fuse F4060 provides additional protection.

The -15 V is supplied from the -26 V dc in the mainframe. Amplifier U4041A compares the regulated +15 V supply with the -15 V through R4041 and R4042. Voltage differences are amplified by U4041 and Q4051. The mainframe PNP transistor and Q4052 form a Darlington series-pass transistor. Frequency compensation for stability is provided by R4054 and C4051. Current limiting is accomplished by Q4044 which senses the current through R4053. When the current delivered by the -15 volt supply exceeds about 500 mA, Q4053 turns on. This shunts base drive current away from Q4052 and lowers the output voltage of the power supply. Fuse F4061 provides additional protection.

**Interface**

13

This circuitry provides an interface between the microprocessor and the Logic Switches shown on schematic 10.

Data on the state of the filter switches as well as the Mode Defeat, Response Drive, IMD Drive and Level Drive input at inputs D0 through D7 on U3010. This integrated circuit is a data selector-multiplexer. The input to be read is selected by lines A, B and C. Data output to the processor is via pin 5.

The filters are controlled via the front panel or the GPIB. The four lines mentioned earlier under this heading are controlled via the processor. This control from the processor passes through U1010, an eight bit addressable latch. The output lines are selected by input lines connected to A, B or C. The status of the output line selected to the latch at pin 13. The output of U1010 can override the front panel filter switches as 20 k resistors are connected between the switches and the level shifters.

Level shifters U2020 and U1020 provide logic compatible voltage levels for the driven circuitry.

## IM Analyzer

14

The IMD Analyzer is block diagrammed in Fig. 4-3. In the difference frequency distortion mode (CCIF) the analyzer is a 1.1 kHz 9-pole Butterworth low pass filter. Two poles of this filter are provided by U3081B and associated components. The CCIF signal then passes to the level sensor composed of Q7071, CR5083 and C6071. Depending on the position of jumper P1053 and the amplitude of low frequency components at the anode of CR5083, multiplexer U8051 selects the output from the SMPTE/DIN demodulator at pin 2 or the partially filtered CCIF signal at pin 3. If approximately 1 V or more of low frequency signal is present at the anode of CR5083, Q7071 turns on. If the jumper is in the automatic position, the collector of U7071 goes low. This lowers pins 9, 10, and 11 of U1240 and connects pin 2 to pin 14, the output. In the CCIF mode, there is little power below 1.0 kHz. Under these conditions Q7071 is off, and pin 3 is connected to pin 14 of U8051.

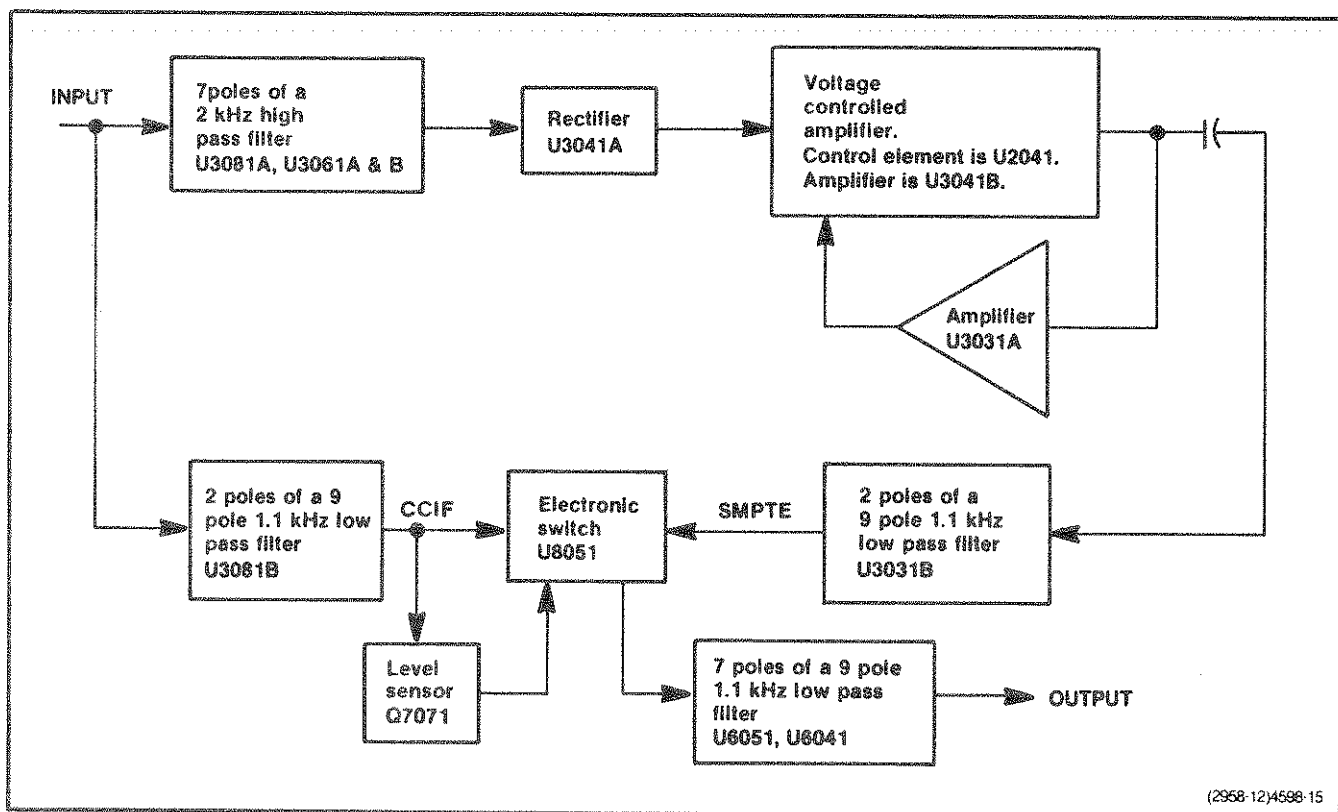

(2958-12)4598-15

Fig. 4-3. Intermodulation distortion analyzer block diagram.

The output of U8051 feeds buffer U6051B. The signals then pass through the remaining 7 poles of the 1.1 kHz low pass filter, comprised of U6051A, U6041A and U6041B, to the distortion amplifier.

In the SMPTE/DIN mode, the input signal passes through 7 poles of a 2 kHz high pass filter to remove the low frequency tone. This filter is composed of U3081A, U3061B and U3061A. The signal is full-wave rectified by U3041A and applied to the input of a voltage controlled amplifier U3041B. To maintain a constant signal amplitude of 3.6 V dc, U3031A integrates the difference between this signal and a dc reference voltage. The current through the LED in gain control resistor U2041 maintains the gain of U3041B so that the output is at 3.6 Vdc. The rectifier signal contains the demodulated SMPTE/DIN IM distortion product and passes through a 30 Hz two pole high pass filter comprised of C2021, C2011, R3021 and R3023 to the input of U3031B. This amplifier, along with C5021, C5023, C3031, and C30331, forms the first two poles of the 9-pole 1.1 kHz low pass filter. Pin 7 of U3031B connects to multiplexer U8051. From this point, the signal is processed exactly the same as the CCIF signal.

**GPIB Circuitry** 15

The microprocessor, U4020, is an eight bit parallel processor with a 16 bit address bus. Two 1024 X 4 RAMS, U3034 and U3043, and one 8192 X 8 ROM, U4030, comprise the microprocessor external memory. The GPIB address switch, S3013, connects to the data bus via U3023, a tri-state buffer. When pins 19 and 1 are low the logic appearing on the A inputs output to the data bus.

The decimal point illuminated appears as a low on the A1 through A4 inputs of U1044. A5 is not used at present. A6 and A7 is the output from the eight channel decoders, U2045 and U2046 that read the illuminated display segments. U2035A and U2035B serve as level shifters from the eight line display segment decoders. Address decoding is accomplished by U2034.

The data bus connects to U3041, an octal flip-flop. The output from this flip-flop drives open collector inverter U3040. The output from this inverter drives the Logic Switch (schematic 10) and Autorange Control Logic (schematic 11) circuitry.

Various display data input to the microprocessor via buffer U1031. GPIB communications are controlled by U2022, U2021 and U1020. Bidirectional buffers U2021 and U1020 provide drive capability for U2022, the GPIB interface. The IEEE 488-1978 standard protocol is handled automatically in both talker and listener modes by U2022.