

Tele Radio T70 Jaguar

INSTALLATION INSTRUCTIONS

FOR RX2-A, RX3-A, TX2

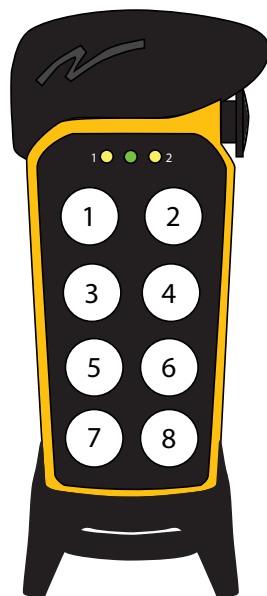

ENGLISH (ORIGINAL)

ARTICLE CODE: T70TX-08ERB2, T70RX-09SB, T70RX-15SB

IM-T70-RX003-A4-EN



Thank you for purchasing a Tele Radio product

T70TX-08ERB2, T70RX-09SB, T70RX-15SB

READ ALL INSTRUCTIONS CAREFULLY BEFORE MOUNTING, INSTALLING AND CONFIGURATING THE PRODUCT.

These instructions are published by Tele Radio AB without any guarantee. These instructions are solely directed towards qualified installers. The information shall not be handed to end users. The instructions may be removed or revised by Tele Radio AB at any time and without any further notice. Corrections and additions will be added to the updated versions of the instructions.

The instructions that contain information on the installation and configuration of the remote radio control unit on the machine are not intended to be passed on to the end user. Only such information may be passed on to the end user, that is needed to operate the machine correctly by radio remote control.

Tele Radio AB products are covered by a guarantee against material, construction or manufacturing faults. During the guarantee period, Tele Radio AB may replace the product or faulty parts with new. Work under guarantee must be carried out by Tele Radio AB or by an authorized service centre specified by Tele Radio AB. Make sure that repairs and maintenance are only carried out by qualified personnel. Use only spare parts from Tele Radio AB. Contact your Tele Radio representative if you want to make a complaint about a product or require other service.

The EC declaration of conformity can be downloaded from our website.

©Tele Radio AB, 2010

TELE RADIO AB
Datavägen 21, SE-436 32 Askim, Sweden
Tel: +46 (0)31-748 54 60
Fax: +46 (0)31-68 54 64
www.tele-radio.com
info@tele-radio.com



The helpdesk group can help you with questions regarding service and technical support.

helpdesk@tele-radio.com

CONTENTS

Frequency table	4
Receiver	5
Transmitter	6
Settings document	6
Technical data	7
Receiver power supply	7
Connect the receiver	8
Install receiver and antenna	8
Install batteries	9
FCC- and IC labels	9
How to remove the rubber cover	9
FCC statement	10
Positions of product labels	10
Starting/ turning the transmitter off	11
Frequency settings	13
Function selection	18
Choose Function selection for the transmitter	18
Operating mode overview	19
Operating modes	20
Change of LED that lights up during startup	28
Power saving for transmitter LEDs	29
Latching relay function	30
Interlocking relay function	31
Register the transmitter in the receiver	32
Erase transmitters	33
Master Reset of the receiver settings	33
LOGOUT transmitters	34
Replace transmitters	35
Battery instruction	36
Disposal	36
Guarantee	37

FREQUENCY TABLE

CHANNEL	FREQ.BANK 1	OPTION	CHANNEL	FREQ.BANK 2	OPTION
1	433.075	111	1	433.100	211
2	433.175	112	2	433.200	212
3	433.275	113	3	433.300	213
4	433.375	114	4	433.400	214
5	433.475	115	5	433.500	215
6	433.575	116	6	433.600	216
7	433.675	117	7	433.700	217
8	433.775	118	8	433.800	218
9	433.875	121	9	433.900	221
10	433.975	122	10	434.000	222
11	434.075	123	11	434.100	223
12	434.175	124	12	434.200	224
13	434.275	125	13	434.300	225
14	434.375	126	14	434.400	226
15	434.475	127	15	434.500	227
16	434.575	128	16	434.600	228

CHANNEL	FREQ.BANK 3	OPTION	CHANNEL	FREQ.BANK 4	OPTION
1	433.125	311	1	433.250	411
2	433.225	312	2	433.350	412
3	433.325	313	3	433.450	413
4	433.425	314	4	433.550	414
5	433.525	315	5	433.650	415
6	433.625	316	6	433.750	416
7	433.725	317	7	433.850	417
8	433.825	318	8	433.950	418
9	433.925	321	9	434.050	421
10	434.025	322	10	434.050	422
11	434.125	323	11	434.150	423
12	434.225	324	12	434.250	424
13	434.325	325	13	434.350	425
14	434.425	326	14	434.450	426
15	434.525	327	15	434.550	427
16	434.625	328	16	434.650	428

RECEIVER

T70RX-09SB

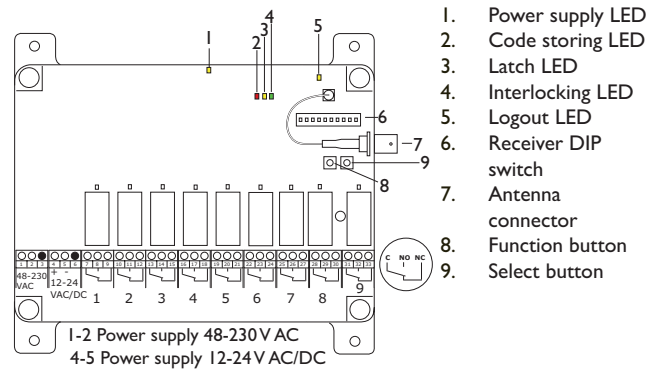

T70RX-15SB

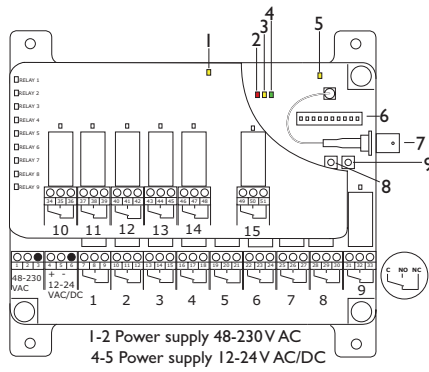

TECHNICAL DATA

The system

OPERATING FREQUENCY: 433.075-434.650 MHz.
CHANNEL: 64 (divided into 4 banks)
CHANNEL SEPARATION: 25 kHz.

Receiver

T70RX-09SB/ RX2-A 9 relays
T70RX-15SB/ RX3-A 15 relays (with expansion board)
WEIGHT: 700 g/24.7 oz. (15 relays)

Transmitter

SIZE: 7.3 cm. x 17.8 cm./2.9" x 7"
(excl. rubber cover)
WEIGHT: 250 g/ 8.8 oz.
(excl. rubber cover, incl. batteries)

RECEIVER POWER SUPPLY

POWER SUPPLY	MIN. CURRENT CONSUMPTION	MAX. CURRENT CONSUMPTION
12V DC	30 mA.	300 mA.
24V DC	15 mA.	200 mA.
24V AC	12 mA.	150 mA.
48V AC	7 mA.	100 mA.
115V AC	7 mA.	50 mA.
230V AC	7 mA.	30 mA.

STOP BUTTON TEST

IMPORTANT! We recommend that the functionality of the STOP button is being tested at a regular basis: At a minimum, when used for 200 hours. Test the STOP button by pressing and pulling it out.

CONNECT THE SYSTEM

CONNECT THE RECEIVER

- Check that you have connected the power supply to the correct connection terminal.
- Note that all relays are potential-free, which means that you need to supply voltage to get power out of a relay (e.g. via a connection comb).

INSTALL RECEIVER AND ANTENNA

- Place as well away from wind, damp and water as possible.
- Cable holders and vent plugs must face down to prevent water from seeping in (see picture).
- If the receiver is to be placed in a hard-to-reach place, it is advisable to complete the settings in the receiver before mounting it.
- Place as high as possible off the ground.
- In as free position as possible.
- Place well away from metal objects, such as metal girders, high-voltage cables and other antennas.
- Check that there is a good connection between the antenna and the material on which it has been installed, e.g. after repainting of the chassis.
- Check that the antenna aerial and any coaxial cables are undamaged.
- Check that the antenna is directed upwards at a 45° angle.

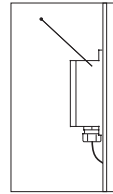

IMPORTANT!

Tele Radio remote controls are often built into wider applications. We recommend that the system is provided with a wired emergency stop where necessary.

INSTALL BATTERIES

1. Remove the battery cover (2 screws).
2. Put the batteries (3 x 1.5V AA batteries) in.
3. Put back the battery cover (2 screws).

For optimum performance, use alkaline batteries.

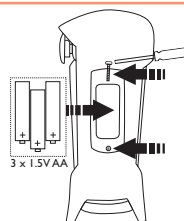

FCC- AND IC LABELS

The rubber cover must be removed to:

1. Reveal the IC-and FCC labels and FCC statements (see picture below).
2. Reveal the ID code for the product (see label placement description on the next page).

HOW TO REMOVE THE RUBBER COVER

The transmitter comes with a removable rubber cover that helps prevent the transmitter from bumps, dirt and dust. The rubber cover can be removed and wiped off.

HOW TO REMOVE THE RUBBER COVER

1. Loosen the rubber cover, starting at the top.
2. Lift the transmitter up out of the rubber cover.

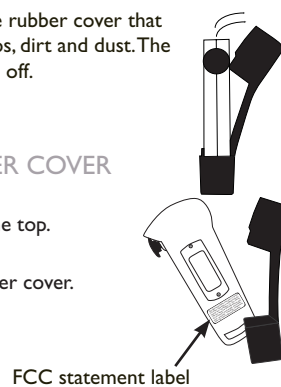

FCC STATEMENT

This device complies with part 15 of the FCC rules. Operation is subject to the following two conditions:

1. This device may not cause harmful interference
2. This device must accept any interference that may cause undesired operation

Note: The manufacturer is not responsible for any radio or TV interference caused by unauthorized modifications to this equipment. Such modifications could void the user's authority to operate the equipment.

POSITION OF PRODUCT LABELS

1. Product ID code
2. IC label
3. FCC label
4. IC, FCC, Serial no/ ID code label
5. FCC statement label

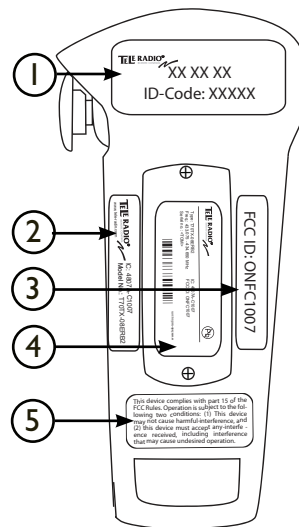

STARTING/ TURNING THE TRANSMITTER OFF

STARTING

1. Pull out the STOP button.



2. Press the START buttons 7 and 8 for at least 1 second.

If the transmitter LED keeps flashing red, the STOP button has not been pulled out. When the transmitter is active, the transmitter LED is flashing green. When the transmitter is transmitting, the transmitter LED lights green continuously.

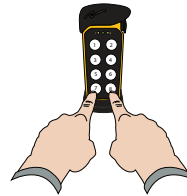

NOTE! If the transmitter LED is lighting or flashing red instead of green, the battery power may be low. Check the batteries.

TURNING OFF

1. Press the STOP button.

NOTE! When the transmitter is active and the stop button is pressed, all relays go off.*



AUTOMATIC SHUTDOWN SETTINGS

Automatic shutdown means that the transmitter will switch itself off, if you do not press a button for 3 minutes (Default setting is 3 minutes, but you can adjust this time according to the table below). The transmitter does not log off from the receiver when it is automatically shut down.

CHANGE AUTOMATIC SHUTDOWN TIME

1. Start the transmitter by pressing the START buttons 7 and 8 for at least 1 second.
2. Keep button 8 pressed. Release button 7.
3. Release button 8. **Within 0.3 seconds:** Press button 3.
Yellow transmitter LED 2 lights up and the green transmitter LED begins to flash.
If you exceed the 0.3 second interval, the transmitter will exit the programming mode and will start up instead.
4. Enter the security code 1, 2, 3, 4 (up to 4 seconds between each number).

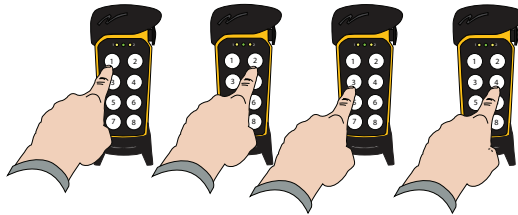

The transmitter LED starts to flash green and yellow transmitter LED 2 goes out.

5. Enter your choice 1-5:

1= no automatic shutdown

2= 1 minute

3= 3 minutes

4= 6 minutes

5= 12 minutes

Yellow transmitter LED 1 flashes 3 times when the time setting has been changed.

6. Write down the new time for automatic shutdown in the Settings document.

FREQUENCY SETTINGS

If your product will be used in an area with very little risk of interference from other radio-controlled equipment, skip this section. If necessary, you can switch the frequency at a later date. (See the first pages of the manual for frequency table).

SWITCH FREQUENCY BANK

NOTE! Make frequency bank settings before storing the transmitter in the receiver. If you want to switch frequency bank after storing the transmitter in the receiver, you will have to erase the transmitter from the receiver, switch frequency bank and then re-store the transmitter in the receiver.

1. Start the transmitter by pressing the START buttons 7 and 8 for at least 1 second.
2. Keep button 8 pressed. Release button 7.
3. Release button 8. **Within 0.3 seconds:** Press button 2.
Yellow LED 2 lights up and the green LED flashes. If you exceed the 0.3 second interval, the transmitter exits programming mode and starts up.
4. Enter the security code 1, 2, 3, 4 (up to 4 seconds between each number).

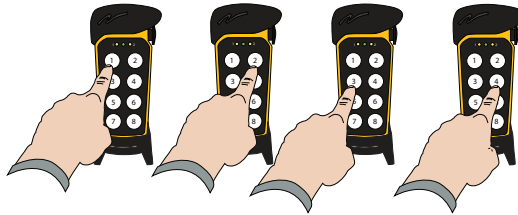

The green LED flashes and yellow LED 2 goes out.

5. Press the 3-digit number for OPTION
(See the first pages of the manual for frequency table).
Yellow transmitter LED 1 flashes 3 times when the setting has been made.

6. Write down the new frequency bank in the Settings document.

SETTINGS TO MOVE UP AND DOWN WITHIN A FREQUENCY BANK

Decide how to move up and down within a frequency bank. Skip this section if you do not want to change the default settings.

1. SAVE NEW FREQUENCY (default setting). When a user moves up or down within a frequency bank, the transmitter saves the new frequency and uses it the next time it is started up.

2. TEMPORARY MOVE When a user moves up or down within a frequency bank, the transmitter will not save the new frequency. The new frequency is only used until the transmitter is restarted.

3. OFF Users are not able to move up or down within a frequency bank.

1. Start the transmitter by pressing the START buttons 7 and 8 for at least 1 second.
2. Release button 7.
3. Keep button 8 pressed.
4. Release button 8.

5. Within 0.3 seconds: Press button 2.

Yellow transmitter LED 2 lights and the transmitter LED begins to flash green. If you exceed the 0.3 second interval, the transmitter will exit the programming mode and starts up.

6. Enter the security code 4, 6, 3, 5 (up to 4 seconds between each number).

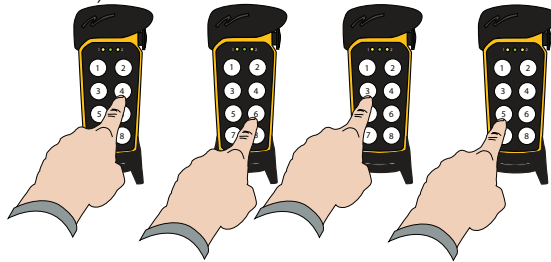

The transmitter LED flashes green. Yellow transmitter LED 2 lights up.
Enter your choice:

1. SAVE NEW FREQUENCY
2. TEMPORARY MOVE
3. OFF

The transmitter turns off.

MOVE UP AND DOWN WITHIN A FREQUENCY BANK

Allowing users to move up and down within a frequency bank when using the transmitter can be useful, if there is a major risk of interference within the work area (see previous section).

1. Start the transmitter by pressing the START buttons 7 and 8 for at least 1 second.
2. Release button 7. Keep button 8 pressed.

1a. Keep button 8 pressed. Press 1 to move DOWN within the frequency.

Yellow transmitter LED 1 lights up.



1b. Keep button 8 pressed. Press 2 to move UP within the frequency.

Yellow transmitter LED 2 lights up.

NOTE! If you move all the way to the bottom of the frequency bank, the next step will be back to the top. If you move all the way to the top of the frequency bank, the next step will be right at the bottom.



2. Release all buttons.

The frequency setting is now changed. Depending on the settings, this may apply until you turn off the transmitter or until the frequency is being switched again.

CHECK THE FREQUENCY ON THE TRANSMITTER

You can use the transmitter to find out what frequency it is currently set to send within.

1. Start the transmitter by pressing the START buttons 7 and 8 for at least 1 second.

2. Release button 7. Keep button 8 pressed.

3. Release button 8. **Within 0.3 seconds:** Press button 2.

Yellow transmitter LED 2 lights up and the transmitter LED flashes green. If you exceed the 0.3 second interval, the transmitter will exit the programming mode and starts up.

4. Enter the security code 3, 4, 4, 3 (up to 4 seconds between each number).

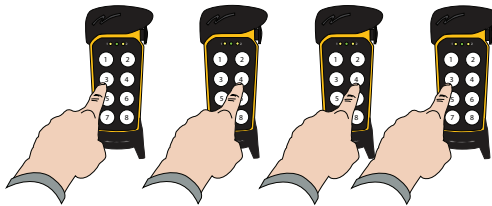

1. FREQUENCY BANK 1-4:

The transmitter LED lights green + yellow transmitter LED 2 flashes 1-4 times depending on what frequency BANK the transmitter is sending on.

2. FREQUENCY CHANNEL 1-16:

The transmitter LED lights red again + yellow transmitter LED 2 flashes 1-16 times depending on what frequency CHANNEL the transmitter is sending on.

The flashing sequence will be repeated until the transmitter is turned off.

FUNCTION SELECTION

Function selection is a functionality choice for the transmitter, which determines how many receivers that can be controlled and how they can be controlled.

Function selection 1	1 receiver Yellow transmitter LEDs not used
Function selection 2	1-2 receivers Receiver 1, receiver 2 or 1+2 at the same time Press button 8, light up yellow transmitter LED 1, 2 or 1+2
Function selection 3	1-2 receivers Receiver 1 or receiver 2- not at the same time Press button 8, light up yellow transmitter LED 1 or 2
Function selection 4	1-2 receivers Receiver 1, receiver 2 or 1+2 at the same time Yellow transmitter LEDs have to be set in advance (Set yellow transmitter LEDs at Start-up) and can not be changed by pressing button 8.

Choose Function selection for the transmitter

1. Press the start-buttons 7+8 for at least 1 sec.
2. Release button 7, keep button 8 pressed.
3. Release button 8. Press button 1 within 0.3 sec.
4. Press the code 1, 2, 3, 4 (a maximum of 5 sec./button). If the code is correct, green LED flashes and yellow LED 2 goes out.
5. Press 1-4 for choice of Function selection 1-4. Yellow LED 1 flashes 3 times.
6. Restart the transmitter.

OPERATING MODE OVERVIEW

OP. MODE	TRANSMITTERS	RECEIVERS	RELAYS	FUNCT. SELECT.	LATCHING	INTER-LOCKING
2	1-3	1-2	9/15	1-4	possible	possible
3	1-3	1-2	9/15	1-4	possible	automatic
4	1-3	1	15	2-4	special	automatic
5	1-3	1-2	15	1-4	possible	automatic
6	1-3	1	15	2-4	special	automatic
7	1-3	1	9	1	possible	possible
8	1-3	1	15	2-4	not possible	automatic
10	1-3	1	15	3 (2-4)	possible	possible

OPERATING MODE 2

RECEIVERS: 9/15 relays
TRANSMITTERS: 1-3
CONTROL: 1-2 receivers
LATCHING: Possible on 4-15
INTERLOCKING: Possible on 4/5/10/11, 6/7/12/13, 8/9/14/15
 1-4
FUNCTION SELECT: Relay 2 activated when buttons 1-6 are pressed.
EXTRA: Relay 1 activated when the start-buttons 7+8 are pressed.

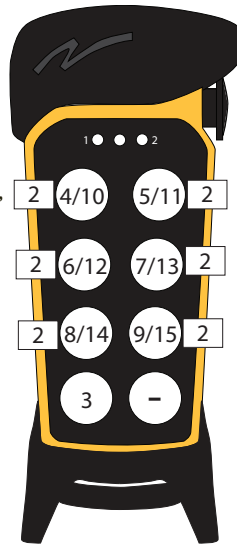
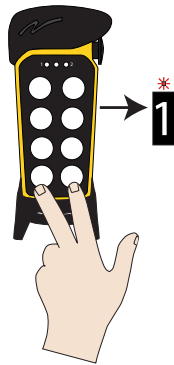

RECEIVER DIPSWITCH



Switch 7:

ON: No time out on relay 1. Only a STOP command from a logged on transmitter will turn relay 1 off.
 OFF: 6 minutes time out on relay 1.
 Switch 9 + 10: Not used.

OPERATING MODE 3

RECEIVERS: 9/15 relays
TRANSMITTERS: 1-3
CONTROL: 1-2 receivers
LATCHING: Possible on 14
INTERLOCKING: Automatically on 4/5/6, 7/8/9, 10/11/12
FUNCTION SELECT: 1-4
EXTRA:

Relay 2 activated when buttons 1-6 are pressed.
 Relay 1 activated when the start-buttons 7+8 are pressed.

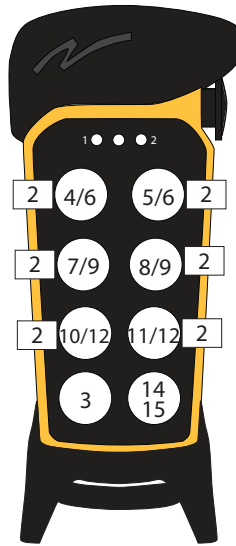
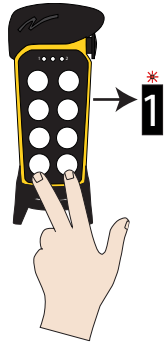

RECEIVER DIPSWITCH

ON	ON	ON	ON	ON	ON	ON	ON	ON	ON
OFF	OFF	OFF	OFF	OFF	OFF	OFF	OFF	OFF	OFF
1	2	3	4	5	6	7	8	9	10

Switch 5:

ON: Button 8 activates relay 14 (latching) and relay 15 (momentary).
 OFF: No function on relay 14 or 15.

Switch 6:

ON: A time delay of 500 ms. when using the high speed function.
 OFF: No time delay between high and low speed functions.

Switch 7:

ON: No time out on relay 1. Only a STOP command from a registered transmitter will turn relay 1 off.
 OFF: 6 minutes time out on relay 1.
 Switch 9 + 10: Not used.

OPERATING MODE 4

RECEIVER MODELS: 15 relays
TRANSMITTERS: 1-3
CONTROL: 1 receiver
LATCHING: Special latching on 14+15
INTERLOCKING: Automatically on 4/5/6, 7/8/9, 10/11/12
FUNCTION SELECT: 2-4
 Relay 2 activated when buttons 1-6 are pressed.
 Relay 1 activated when the start-buttons 7+8 are pressed.

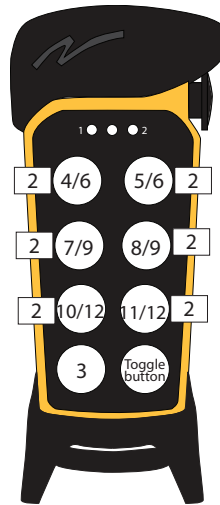

Special relay function

See Function selection chapter

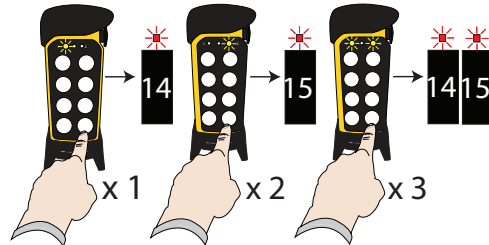

RECEIVER DIPSWITCH



Switch 6:

ON: A time delay of 500 ms. when using the high speed function.

OFF: No time delay between high and low speed functions.

Switch 7:

ON: No time out on relay 1. Only a STOP command from a registered transmitter will turn relay 1 off.

OFF: 6 minutes time out on relay 1.

Switch 9 + 10: Not used.

OPERATING MODE 5

RECEIVER MODELS: 15 relays
TRANSMITTERS: 1-3
CONTROL: 1-2 receivers
LATCHING: Possible on 14
INTERLOCKING: Automatically on 4/6/5/7, 8/9/10, 11/12/13
FUNCTION SELECT: 1-4
EXTRA: Relay 2 activated when buttons 1-6 are pressed
 Relay 1 activated when the start-buttons 7+8 are pressed

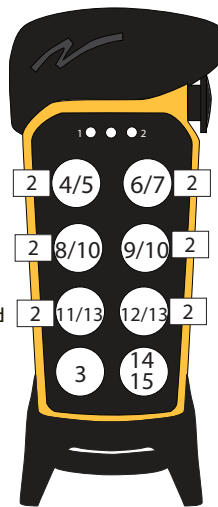
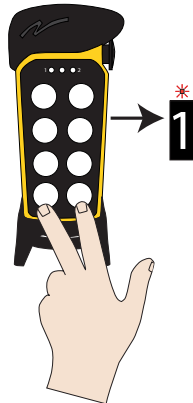

RECEIVER DIPSWITCH



Switch 5:

ON: Button 8 activates relay 14 (latching) and relay 15 (momentary).
 OFF: No function on relay 14 or 15.

Switch 6:

ON: A time delay of 500 ms. when using the high speed function.
 OFF: No time delay between high and low speed functions.

Switch 7:

ON: No time out on relay 1. Only a STOP command from a registered transmitter will turn relay 1 off.
 OFF: 6 minutes time out on relay 1.
 Switch 9 + 10: Not used.

OPERATING MODE 6

RECEIVER MODELS: 15 relays
 TRANSMITTERS: 1-3
 CONTROL: 1 receiver
 LATCHING: Special latching on 14+15

INTERLOCKING: Automatically on 4/6/5/7, 8/9/10, 11/12/13

FUNCTION SELECT: 2-4
 Relay 2 activated when buttons 1-6 are pressed.
 Relay 1 activated when the start-buttons 7+8 are

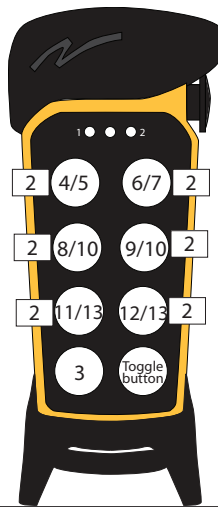

Special relay function

See Function selection chapter

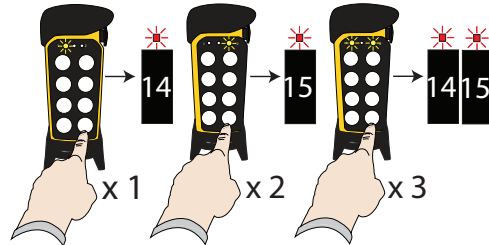

RECEIVER DIPSWITCH



Switch 6:

ON: A time delay of 500 ms. when using the high speed function.
 OFF: No time delay between high and low speed functions.

Switch 7:

ON: No time out on relay 1. Only a STOP command from a registered transmitter will turn relay 1 off.
 OFF: 6 minutes time out on relay 1.

Switch 9 + 10: Not used.

OPERATING MODE 7

RECEIVER MODELS: 9 relays
 TRANSMITTERS: 1-3
 CONTROL: 1 receiver
 LATCHING: Possible on 2-15
 INTERLOCKING: Possible on 2/3/10/11,
 4/5/12/13, 6/7/14/15,
 8/9
 FUNCTION SELECT: 1
 EXTRA: -

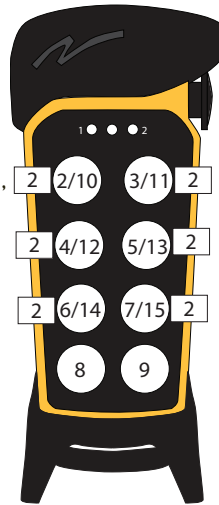

RECEIVER DIPSWITCH

ON	ON	ON	ON	ON	ON	ON	ON	ON	ON
OFF	OFF	OFF	OFF	OFF	OFF	OFF	OFF	OFF	OFF
1	2	3	4	5	6	7	8	9	10

Switch 7:

ON: No time out on relay 1. Only a STOP command from a loggic on transmitter will turn relay 1 off.
 OFF: 6 minutes timeout on relay 1.

Switch 8:

ON: Relay 1=working relay functionality; activated when any of the relays 2-9 are activated.

OFF: Relay 1=stop relay functionality; activated for 6 minutes or until stop command is received, depending on setting for switch 7.

Switch 9 + 10: Not used.

OPERATING MODE 8

RECEIVER MODELS: 15 relays
 TRANSMITTERS: 1-3
 CONTROL: 1 receiver
 LATCHING: -
 INTERLOCKING: Automatically on
 4/5/6, 7/8/9, 10/11/12,
 13/14/15

FUNCTION SELECT: 2-4
 EXTRA: Relay 2 activated when
 buttons 1-6 are pressed
 Relay 1 activated
 when the start-
 buttons 7+8 are
 pressed

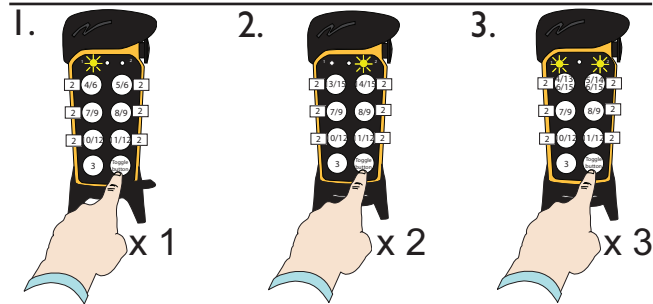
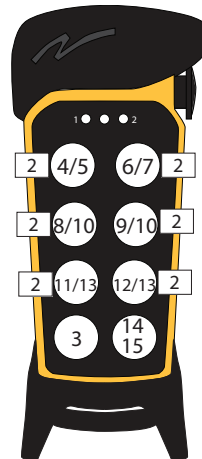
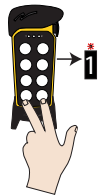

RECEIVER DIPSWITCH



Switch 6:

ON: A time delay of 500 ms. when using the high speed function.
 OFF: No time delay between high and low speed functions.

Switch 7:

ON: No timeout on relay 1. Only a STOP command from a registered transmitter will turn relay 1 off.
 OFF: 6 minutes timeout on relay 1.

Switch 8:

ON: Relay 1=working relay functionality: activated when any of the relays 2-9 are activated.
 OFF: Relay 1=stop relay functionality: activated for 6 minutes or until stop command is received, depending on setting for switch 7.
 Switch 9 + 10: Not used.

OPERATING MODE 10

RECEIVER MODELS: 15 relays
TRANSMITTERS: 1-3
CONTROL: 1 receiver
LATCHING: Possible on 2-15
INTERLOCKING: Possible on 2/3, 4/5, 6/7, 9/10, 11/12, 13/14
FUNCTION SELECT: 2-4 possible
 (3 recommended)

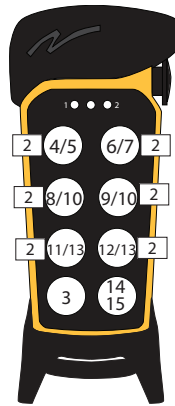

Select function bank

1.

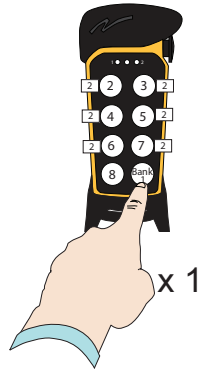

2.

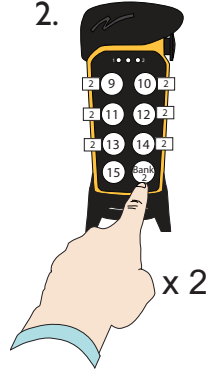

RECEIVER DIPSWITCH



Switch 7:

ON: No time out on relay 1. Only a STOP command from a logged on transmitter will turn relay 1 off.
OFF: 6 minutes timeout on relay 1.

Switch 8:

ON: Relay 1=working relay functionality: activated when any of the relays 2-9 are activated.
OFF: Relay 1=stop relay functionality: activated for 6 minutes or until stop command is received, depending on setting for switch 7.
 Switch 9 + 10: Not used.

CHANGE OF LED THAT LIGHTS UP DURING STARTUP

Select how the yellow LEDs on the transmitter will light up when you start the transmitter. Default setting= yellow LED 1 lights up when the transmitter is started. If you want to keep the default setting, skip this section.

1. No yellow LED lights up at start
2. Yellow LED 1 lights up at start
3. Yellow LED 2 lights up at start
4. Yellow LEDs 1 + 2 light up at start

1. Start the transmitter by pressing the START buttons 7 and 8 for at least 1 second.

2. Release button 7. Keep button 8 pressed.

3. Release button 8. **Within 0.3 seconds:** Press 1.

Yellow LED 2 lights up. The LED starts to flash green.

4. Enter the security code 7, 4, 8, 3 (up to 4 seconds between the numbers).

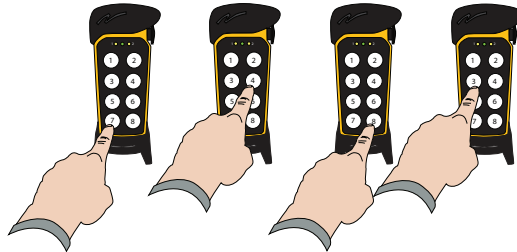

The green LED starts to flash and yellow LED 2 goes out.

5. Enter your choice:

1. No yellow LED lights up
2. Yellow LED 1 lights up
3. Yellow LED 2 lights up
4. Yellow LEDs 1 + 2 light up

POWER SAVING FOR TRANSMITTER LEDS

When the transmitter is in Standby mode (i.e. not transmitting) the default setting is that the selected yellow LEDs are continuously lit. You can increase the battery life by changing the settings. If you want to keep the default setting, skip this section.

- A. The selected Yellow LEDs are continuously lit
- B. Selected LEDs flash

1. Start the transmitter by pressing the START buttons 7 and 8 for at least 1 second.

2. Release button 7. Keep button 8 pressed.

3. Release button 8. **Within 0.3 seconds:** Press 1.

Yellow LED 2 lights up. The LED starts to flash green.

4. Enter the security code 7, 5, 4, 5 (up to 4 seconds between the numbers).

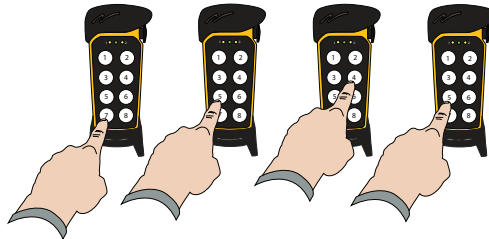

The green LED starts to flash and yellow LED 2 goes out.

5. Enter your choice (1 or 2).

Yellow LED 1 flashes 3 times.

LATCHING RELAY FUNCTION

In some Operating Modes you can assign a latching function to certain relays (see description of *Operating Modes*). Latching means that the relay is activated every time a button is pressed, but remains active until the button is pressed again. You can set this on the receiver using the FUNCTION button and the SELECT button.

1. Use the FUNCTION button to switch between the 3 function LEDs:

- A. the red code storing LED
- B. the yellow latch LED
- C. the green interlocking LED



2. Stop at the latch LED and select it by pressing the SELECT button. The latch LED will go out. The red LED above relay 4 will light up.

3. Use the SELECT button to select the relay that you want to assign a latching function. Press the FUNCTION button to light up the latch LED. If the latch LED is already lit and the red LED above a relay lights up, this relay has already been assigned a latching function. To remove the latching function from a relay, press the FUNCTION button once, so that the latch LED goes out.

4. To assign latching to more relays, use the SELECT button to select the next relay that you want to assign a latching function to. The receiver will exit the code storing mode after 10 seconds idling.

INTERLOCKING RELAY FUNCTION

In some Operating Modes you can assign an interlocking function to certain relays (see description of Operating Modes). Interlocking means that you can prevent selected relays from activating at the same time, even if the buttons are pressed at the same time, e.g. moving up and down. If two relays are interlocked, nothing will happen if the user presses both buttons at the same time. You can set this on the receiver using the FUNCTION button and the SELECT button.

1. Use the FUNCTION button to switch between the 3 function LEDs:

- A. the red code storing LED
- B. the yellow latch LED
- C. the green interlocking LED



2. Stop at the interlocking LED and select it by using the SELECT button. The interlocking LED goes out. The red LEDs above relays 4 and 5 will light up.

3. Press the FUNCTION button to light up the interlocking LED. If the interlocking LED is already lit and the red LEDs above a relay pair light up, this relay pair has already been assigned an interlocking function. To remove the interlocking function from a relay pair, press the FUNCTION button once, so that the interlocking LED goes out.

4. To assign interlocking to more relay pairs, use the SELECT button to select the next relay pair that you want to assign an interlocking function. The receiver will exit code storing mode after 10 seconds idling.

REGISTER THE TRANSMITTER IN THE RECEIVER

IMPORTANT! Do not register the transmitter in the receiver until you have selected Operating Mode.

Depending on receiver model, you can register 1-3 transmitters. If the maximum number of transmitters has already been registered, all transmitters must be erased before you can register the transmitters that you want. NOTE! If several transmitters are used with one receiver, they must all use the same frequency bank.

1. Start the transmitter that you want to register.

NOTE! If you are going to register the transmitter in 2 receivers and have chosen Function selection 2-4, make sure that the correct yellow transmitter-LED is lit when registering the transmitter.

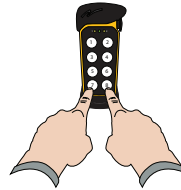

2. Press transmitter buttons 1+2 at the same time. **Keep pressed until all steps have been performed.**



3. Press the receiver FUNCTION button until the red code storing LED on the receiver lites up.

4. Press the receiver SELECT button until all red relay LEDs lit up.

The receiver starts to search for and connect to the transmitter. When the transmitter has been stored, the red relay LEDs on the receiver flash 3 times.

5. Release transmitter buttons 1 + 2.

ERASE TRANSMITTERS

1. Press the receiver's FUNCTION button for more than 0.3 seconds.

The red code storing LED on the receiver lights up.

2. Press the SELECT button.

All the red relay LEDs lights up.

Hold down the SELECT button for more than 4 seconds.

3. All the red relay LEDs on the receiver will go out when all transmitters have been deleted.

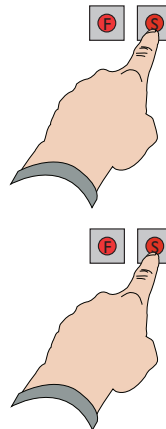

MASTER RESET OF THE RECEIVER SETTINGS

If you need to delete the settings you have made on the receiver (storing of transmitters as well as interlocking and latching relay functions), you can perform a Master Reset. The Operating Mode will not be deleted. To switch Operating Mode, change the position of receiver switch 1-4.

1. Press both the FUNCTION button and the SELECT button.

All three function LEDs (the red code storing LED, the yellow latch LED and the green interlocking LED) light up.

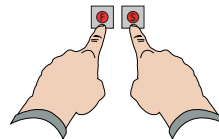

2. Hold down the FUNCTION button and the SELECT button for more than 4 seconds. After 4 seconds the receiver's memory has been erased.

LOGOUT TRANSMITTERS

If you want to use more than one stored transmitter with your receiver, you must log out the transmitter that you used last. There are 3 ways to log a transmitter out:

LOGOUT 1

1. Start the transmitter that you want to LOGOUT.
2. Press the transmitter's STOP button.
3. When the transmitter's red LED begins to flash, press button 7 within 2 seconds.

Yellow transmitter LED 1 starts to flash.

4. The transmitter is now logged out. You can now log on to the receiver using another stored transmitter.

LOGOUT 2- ONLY IF BUTTON 7 IS NOT USED FOR A HIGH-RISK FUNCTION

1. Start the transmitter you want to log out.
2. Press button 7.
3. Press the STOP button without releasing button 7.
The red transmitter LED lights up for 1 second. Yellow transmitter LED 1 flashes.
4. The transmitter is now logged out and turns itself off. You can now log on to the receiver using another stored transmitter.

LOGOUT 3- IF TRANSMITTER CANNOT BE USED

1. Press the SELECT button for at least 4 seconds. The green LOG ON/OFF LED on the receiver will go out.
2. You can now log on to the receiver using another stored transmitter.

REPLACE TRANSMITTERS

To replace a lost or broken transmitter with a new, without having to use the receiver. Simply use the new transmitter for all button operations.

NOTE! The new transmitter must use the same frequency bank as the transmitter that is being replaced.

1. Start the new transmitter.

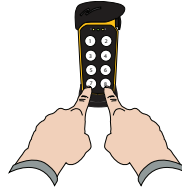

2. Press the new transmitter's STOP button.

The transmitter LED lights red.



3. **Within 2 seconds:** Press button 5 and 6.

Yellow transmitter LED 1 lights.

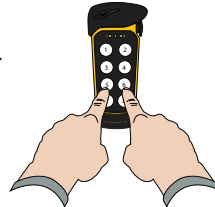

4. Enter the ID code for the transmitter that you want to erase. (Label placed under the rubber cover)

The transmitter LED lights red. Yellow transmitter LED 2 flashes.

The new transmitter can now be used with the receiver.

BATTERY INSTRUCTION

Observe the following warnings.

As batteries contains flammable substances such as lithium or other organic solvents, they may cause heating, rupture or ignition.

- Risk of explosion if battery is replaced with a battery of an incorrect type.
- Do not short circuit, disassemble, deform or heat batteries.
- Never try to charge a visibly damaged or frozen battery.
- Do not charge rechargeable batteries with a higher voltage than specified.
- Keep batteries out of reach of small children. Should a child swallow a battery, consult a physician immediately.
- Avoid direct soldering to batteries.
- When discarding batteries, insulate the + and - terminals of batteries with insulating/ masking tape. Do not put multiple batteries in the same plastic bag.
- Store in a cool location. Keep batteries away from direct sunlight, high temperature, and high humidity.
- Do not throw batteries into fire.

DISPOSAL

DISPOSAL OF BATTERIES

All batteries shall be recycled. Contact your local government's recycling or solid waste department for more information on proper recycling of batteries in your region.

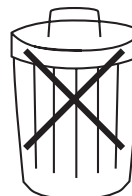

DISPOSAL OF ELECTRONICS

Improperly disposed electronics may harm public health and the environment. Batteries and electronic waste may contain toxic heavy metals. If thrown away in the trash, the toxic compounds can leach into soil and water, pollute lakes and streams, making them unfit for drinking, swimming, fishing, and wildlife. Contact your local government's recycling or solid waste department for more information on proper disposal of electronics in your region.

GUARANTEE

Tele Radio's products are covered by a guarantee against material, construction or manufacturing faults.

- During the guarantee period Tele Radio may replace the product or faulty parts with new ones. Work under warranty must be carried out by Tele Radio or by an authorized service centre specified by Tele Radio.
- The following faults are not covered by the warranty:
- Faults resulting from normal wear and tear.
- Parts of a consumable nature.
- Products that have been subject to unauthorized modifications.
- Faults resulting from incorrect installation or use.
- Damp or water damage.

SERVICING & REPAIRS

Make sure that repairs and maintenance are only carried out by qualified personnel. Only use spare parts from Tele Radio. Contact your dealer if you want to make a complaint about a product or require other service. Always have the following details to hand when you contact a dealer about a complaint or service issue: Name of the system, model and a description of the problem. If you need to return a product, the invoice number and delivery date should be included.

OPERATING GUIDELINES

- Keep the product in a dry, clean place.
- Make sure that contacts and antennas are kept clean.
- Wipe off dust using a slightly damp, clean cloth.
- Never use cleaning solutions or high-pressure water.

SAFETY GUIDELINES

According to the Machinery Directive 2006/42/EC we recommend a wired emergency stop where applicable, as well as other protections against personal injuries, e.g. pinch protection for sliding car doors. The radio control system should only be used for functions such as starting and halting of an application. The radio control system must not be a safety-related part of a control system.

TELE RADIO AB
Sweden, Main Office
Tel. +46 (0)31-748 54 60
e-mail: info@tele-radio.com

TELE RADIO SVERIGE
Sweden
Tel. +46 (0)31-724 98 00
e-mail: sverige@tele-radio.com

TELE RADIO LTD
England
Tel. +44 (0)1625 509125
e-mail: england@tele-radio.com

www.tele-radio.com

TELE RADIO GmbH
Germany
Tel. +49 (0)914 51-944 8 550
e-mail: deutschland@tele-radio.com

TELE RADIO LLC
North America & Latin America
Tel. +1 (202) 652 0753
e-mail: america@tele-radio.com

TELE RADIO ASIA
China
Tel. +86 (0)592-3111168
e-mail: china@tele-radio.com

TELE RADIO BY
Belgium
Tel. +31 (0)70-419 41 20
e-mail: belux@tele-radio.com

TELE RADIO TURKEY
Turkey
Tel. +90 216 574 22 94
e-mail: turkey@tele-radio.com

TELE RADIO AS
Norway
Tel. +47 6933 4900
e-mail: norge@tele-radio.com