



# Manual

and installation instructions

Technology by:



Table of contents

**Getting started ..... 3**

Control panel ..... 4

    Raise/lower the boat using automatic systems .....4

    Raising/lowering the boat manually .....5

    Adjusting the boat hoist level .....6

    Raising/lowering the boat outside of the boat hoist's stopping positions.....7

Remote control ..... 8

    Raising/lowering the boat using remote control .....8

    Other remote control functions:..... 10

**Installation ..... 11**

    Limit switch ..... 12

    Functional description of limit switch ..... 13

    Adjustment of limit switch (hoist) ..... 14

    Adjusting the limit switch (lowering) ..... 15

    Connection of limit switch to radio receiver ..... 16

**Installation ..... 17**

    Mounting the limit switch into the hoist motor..... 18

    SAFETY II stop function..... 23

**General notice..... 24**

**Installation ..... 25**

    Connecting hoist motors to the control panel..... 26

*Standard color coded motor*..... 26

*Standard T-motor* ..... 28

*Eastbay motor* ..... 30

*AO Smith motor* ..... 32

*Leeson Baldor motor*..... 34

*General Electric motor*..... 36

*Century Magnatech motor* ..... 38

*Emerson motor*..... 40

*Leeson motor*..... 42

*Baldor motor* ..... 44

**Appendix 2-motor lifts..... 46**

    Connection schematics ..... 47

    Wire size recommendation chart ..... 54

    Pairing a transmitter to the TigerShark ..... 56

    Deleting transmitters for the TigerShark..... 57

**Appendix 4-motor lifts..... 58**

    Connection schematics ..... 59

---

# Getting started

How to use the control panel and the remote control for the boat hoist

**WARNING** any adjustment to TigerShark not described in this manual or approved in writing by TeleRadio voids warranty and releases TeleRadio and its subsidiaries from liability due to improper handling or installation.

The radio control system should only be used for functions such as starting and halting of an application. The radio control systems must not be a safety-related part of a control system. We recommend a wired emergency stop where applicable, as well as other protections against personal injuries, e.g. pinch protection.

All maneuvering of the lift has to be monitored by the user.

AUTO stop function is a convenience function, lift still has to be monitored by the user.

SAFETY function is in place to minimize damage in the event of lift failure, lift still has to be monitored by the user.

**WARNING** when lift is not in use the power should be disconnected either at the mains power switch or at the ground fault interruptor switch in the control panel housing.

**WARNING** the control panel housing should always be locked or screwed shut to avoid use by unauthorized party(ies).

**WARNING** the lift should only be operated by users who have read and understood the instructions.

**WARNING** do not climb or play on the lift as there is risk for personal injury.

**WARNING** electrical installation can only be performed by licensed electricians.

Explanation of signs:

## Control panel

 = Quick press    
 
 = Hold down/up

### Raise/lower the boat using automatic systems

You can use the automatic systems to raise or lower the boat to a preset position by briefly pressing the boat up/down lever. The boat can be raised or lowered to the position set as the end point during installation. See page 12.

Raising the boat automatically:

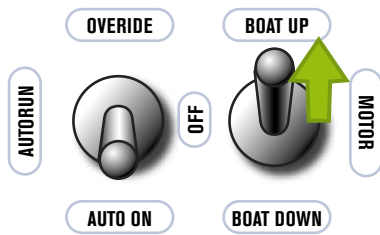

Lowering the boat automatically:

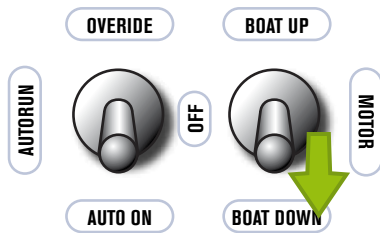

---

## Raising/lowering the boat manually

---

You can lower or raise the boat manually without using the automated stopping system. When the boat has been raised or lowered to its final position, the hoist turns off. The boat is only raised or lowered as long as the lever is held up or down. The boat can be lowered or raised to the position set as the end position. See page 12.

Raising the boat manually:

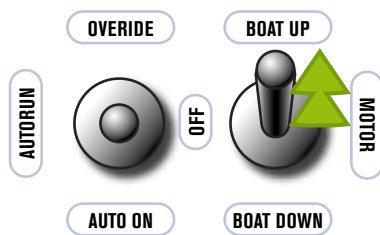

Lowering the boat manually:

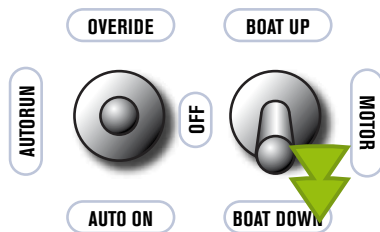

## Adjusting the boat hoist level

You can adjust the level of the hoist motors using the control panel. Do this by turning off one of the motors using the LEVEL breaker. This may be necessary if the boat hoist is on a slant or if a level adjustment must be performed for other reasons.

**WARNING!** Be careful when adjusting the level, as too high an adjustment can endanger the boat hoist's load.

Adjusting the level of the hoist upward:

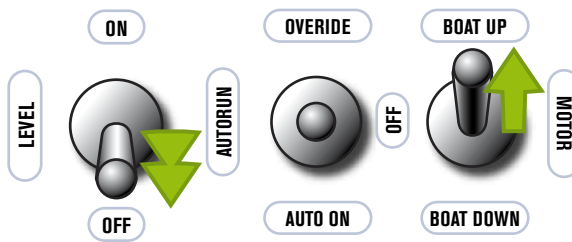

Note! The motor used for level adjustment varies depending on the boat hoist. Check with your installer before use.

Adjusting the level of the hoist downward:

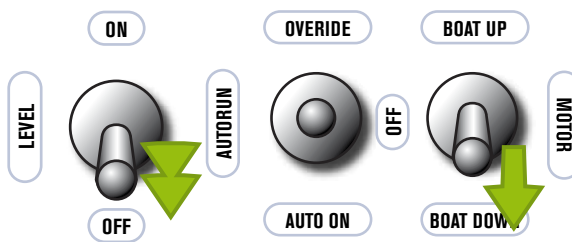

Note! The motor used for level adjustment varies depending on the boat hoist. Check with your installer before use.

---

## Raising/lowering the boat outside of the boat hoist's stopping positions.

---

You can lower or raise the boat outside of the preset stopping positions for the boat hoist. This can be useful (i.e. at high or low tide), when the hoist doesn't reach high or low enough. Hold the lever toward the STOP POSITION to get past the automatic stop.

**WARNING!** Raising/lowering the boat outside of the preset end positions can lead to serious equipment damage if proper care is not exercised. For this reason, be very careful when using this function.

Raising outside of stop positions:

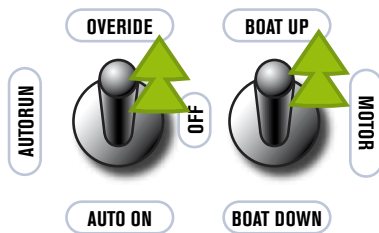

Lowering outside of stop positions:

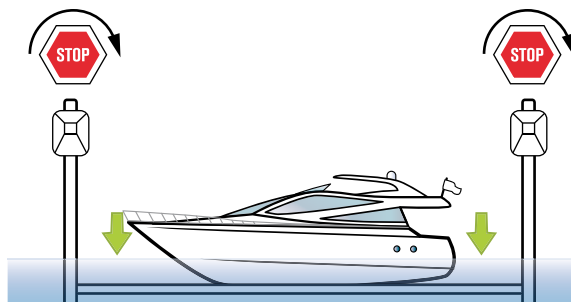
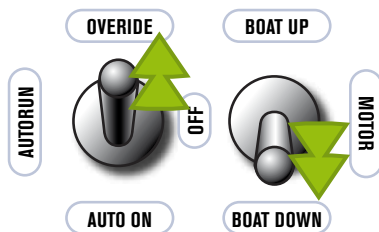

## Remote control

### Raising/lowering the boat using remote control

You can automatically\* lower or raise the boat to a preset position by briefly pressing either the up or down button. The boat is lowered or raised to the position set as the end point during installation.

Raising the boat automatically\*:

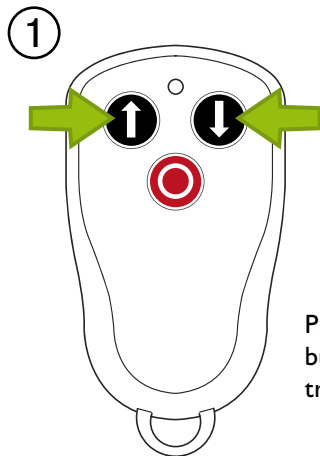

Press both arrow buttons to turn transmitter power on.

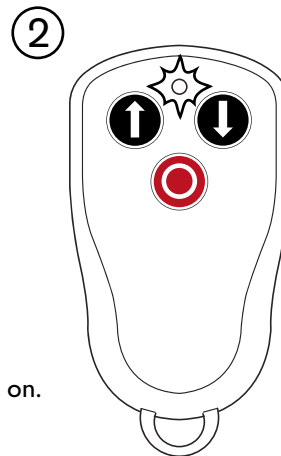

The LED turns on.

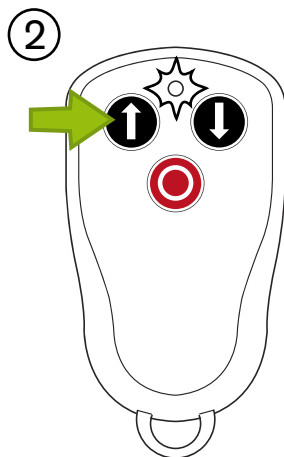

Pressing the up button will raise the boat hoist to the stop position.



**\*)** If your lift is **not** equipped with a **limit switch**, you do not have the automatic lift/lower functionality. You must then continuously hold the up/down button. Be aware that the lift can then be raised/lowered outside its maximum limits with possible equipment damage or personal injury as a result.

Transmitter times out after 2 minutes of inactivity. To re-activate, repeat step 1.  
Note: Transmitter is already paired with the receiver.



Lowering the boat automatically\*:

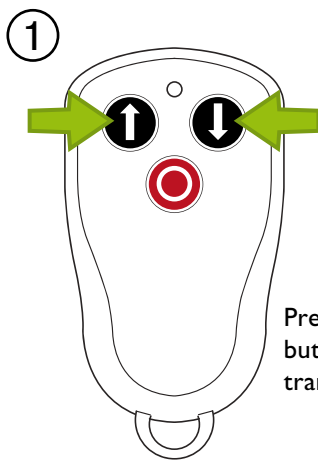

Press both arrow buttons to turn transmitter power on.

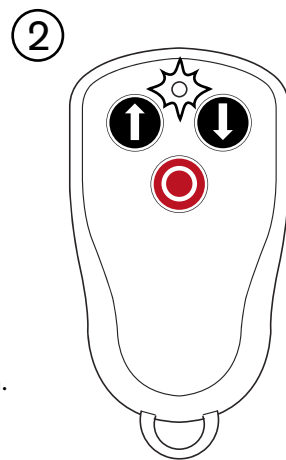

The LED turns on.

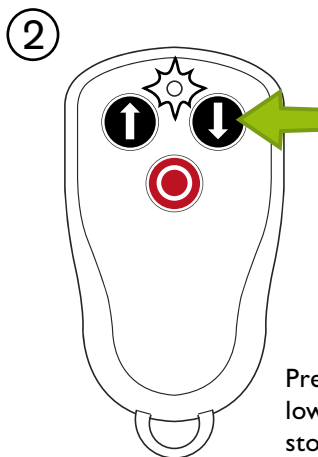

Pressing the down button lowers the boat hoist to the stop position.



**\*)** If your lift is **not** equipped with a **limit switch**, you do not have the automatic lift/lower functionality. You must then continuously hold the up/down button. Be aware that the lift can then be raised/lowered outside its maximum limits with possible equipment damage or personal injury as a result.

Transmitter times out after 2 minutes of inactivity. To re-activate, repeat step 1.  
Note: Transmitter is already paired with the receiver.

Other remote control functions:

The remote control can also be used to control other objects on or around the boat. The standard remote control supports the control of two different objects. You will find suggestions below. Your re seller can provide you with a transmitter that allows you to control several objects at once. Contact your re seller for more information. Please note that extra equipment may be required.

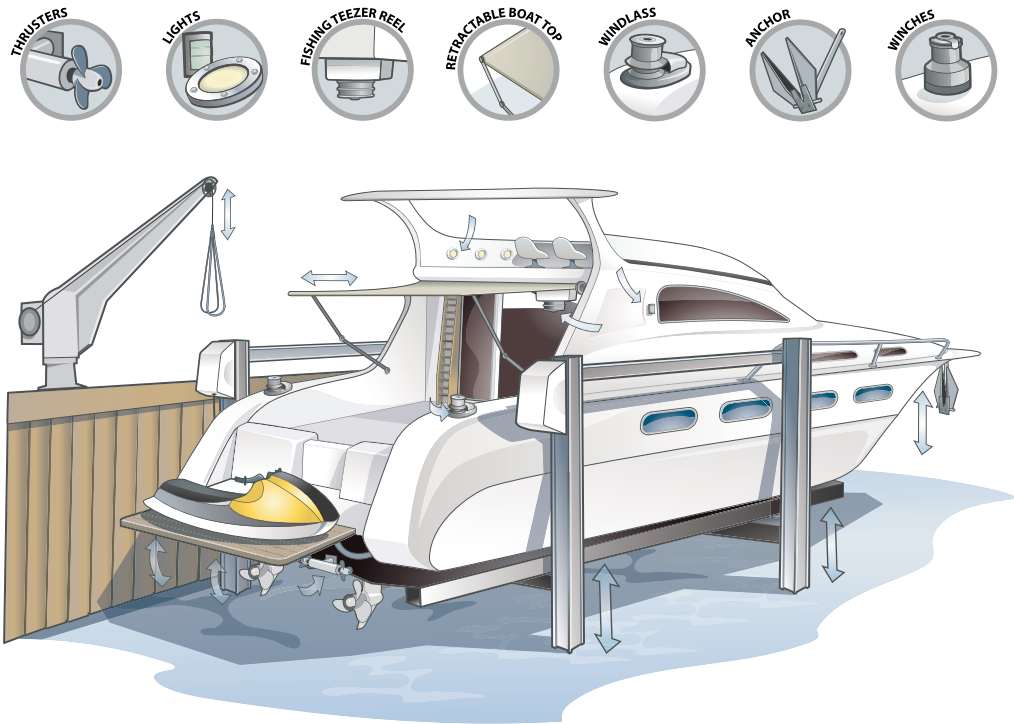

Other objects may include jet ski hoists, harbour cranes, boat cranes, ramps or boat traverses.

---

# Installation

How to install **the control panel**

**WARNING!** *This section of the manual is only for licensed electricians and installers. Interference with high-voltage equipment is illegal for individuals without the required training/authorization.*



## Limit switch

---

The limit switch is connected to the boat hoist motor. With the help of a micro-breaker, this unit senses how high or how low the boat hoist has been moved. When the boat hoist is in the top position, a high position breaker cuts the power to the motor. When the boat hoist is in the bottom position, a low position breaker cuts the power to the motor.

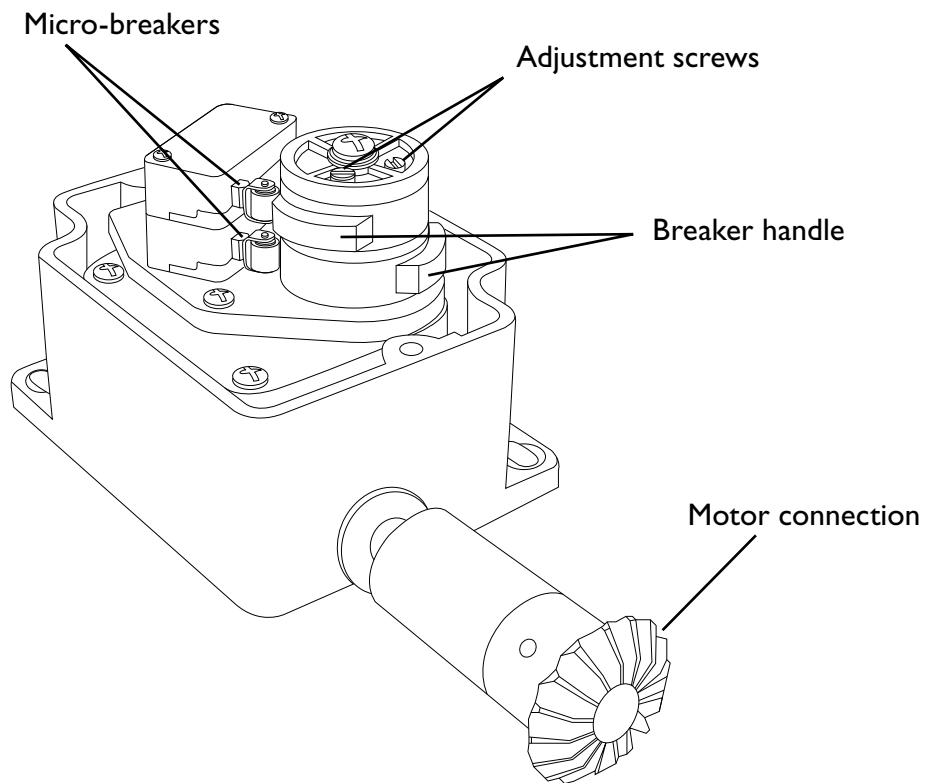

---

## Functional description of limit switch

---

The limit switch, which connects to the engine axle, is turned when the engine axle is spinning, turning the breaker handle in turn. The breaker handle should be adjusted so that when the engine axle is spinning enough, (i.e. when the hoist is in the desired top or bottom position), the micro-breakers engage to cut the power to the motor.

**WARNING!** *Be careful to check which breaker handle is for the top position and which is for the bottom position. This depends on how the limit switch is installed.*

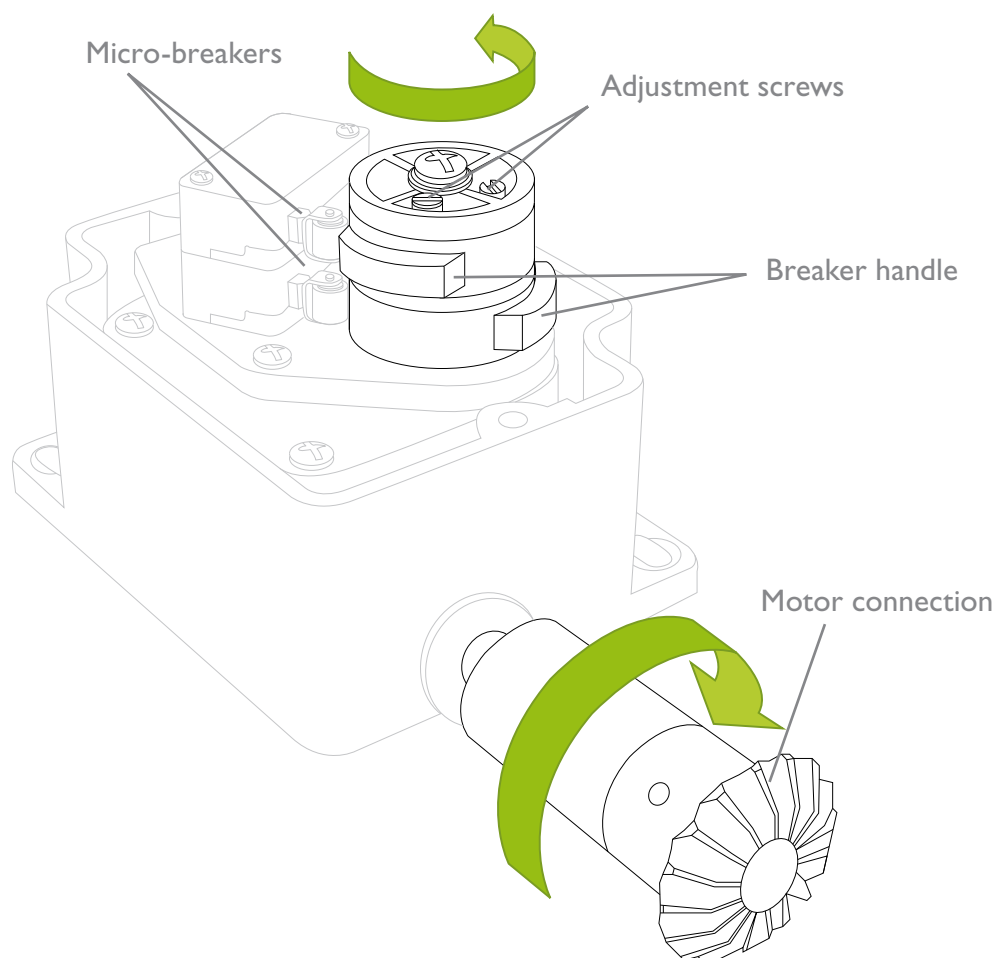

## Adjustment of limit switch (hoist)

In order for the limit switch to work properly, it needs to be adjusted upon installation. This is done in two steps, first when the boat hoist is in the top position, and then when it is in the bottom position - this is when the breaker handles are adjusted.

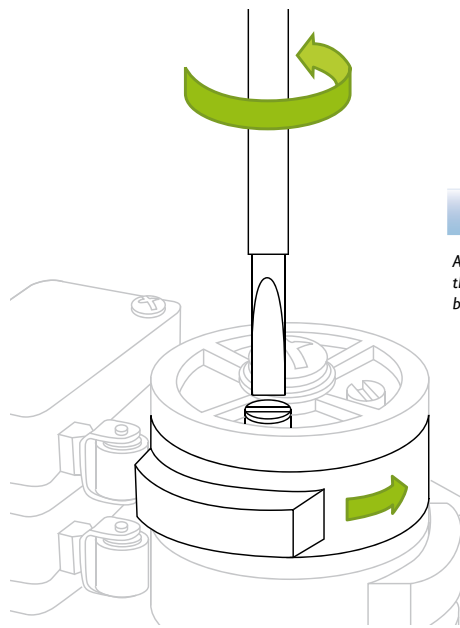

Adjust the boat hoist or the hoisting motors to the position that corresponds to the hoist's top position. That is, the highest position you want to be controlled by "AUTORUN."

*NOTE! In this example, the lower breaker has been chosen to control the lowering relay. This may vary by installation. Depending on how the position indicator is attached, the meaning of the breakers may be reversed. For this reason, take the necessary precautions during installation and testing to prevent damage to people or property.*

When the hoist is in the desired top position, turn the screw that corresponds to the handle/breaker you selected to regulate the height. Turn the screw until the breaker handle activates the micro-breaker with a click.

When the breaker handle reaches this position during a hoist, the micro-breaker will cut power to the relay that controls the hoist function.

**NOTE!** This function must be checked carefully to avoid incorrect boat hoist operation.

---

## Adjusting the limit switch (lowering)

---

In order for the limit switch to work properly, it needs to be adjusted upon installation. This is done in two steps, first when the boat hoist is in the top position, and then when it is in the bottom position - this is when the breaker handles are adjusted.

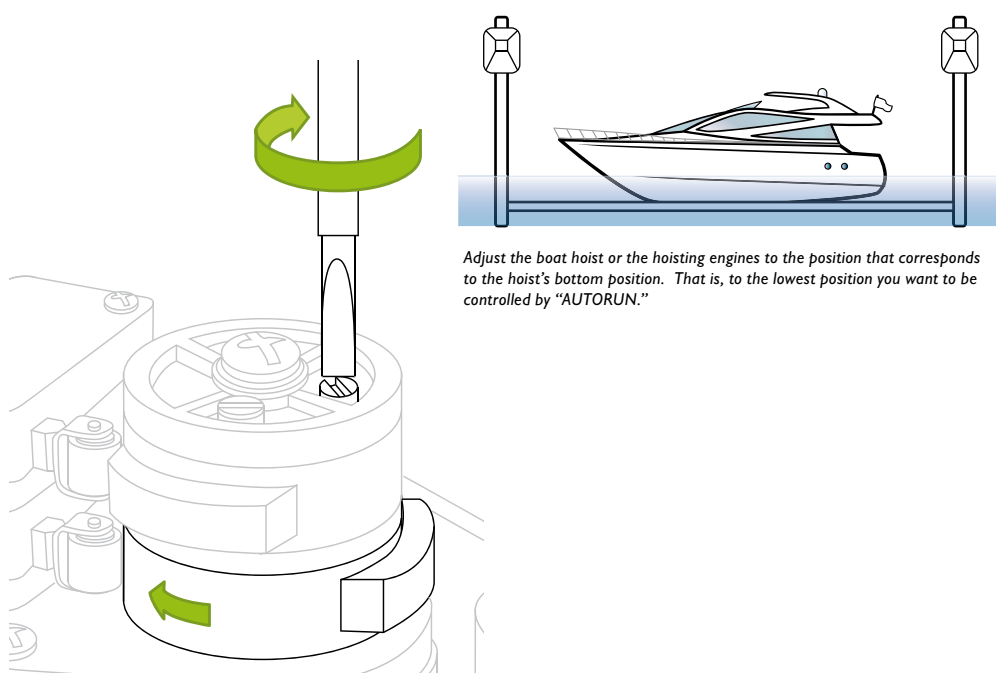

Adjust the boat hoist or the hoisting engines to the position that corresponds to the hoist's bottom position. That is, to the lowest position you want to be controlled by "AUTORUN."

**NOTE!** In this example, the lower breaker has been chosen to control the lowering relay. This may vary by installation. Depending on how the position indicator is attached, the meaning of the breakers may be reversed. For this reason, take the necessary precautions during installation and testing to prevent damage to people or property.

When the hoist is in the desired bottom position, turn the screw that corresponds to the handle/breaker you selected to regulate the lowering function. Turn the screw until the breaker handle activates the micro-breaker with a click. When the breaker handle reaches this position during lowering, the micro-breaker will cut the power to the relay that controls the lowering function.

**NOTE!** This function must be checked carefully to avoid incorrect boat hoist operation.

## Connection of limit switch to radio receiver

Below, you'll see how the connections should be drawn from the micro-breakers' poles to the radio receiver in the control panel.

Connections between limit switch and receiver

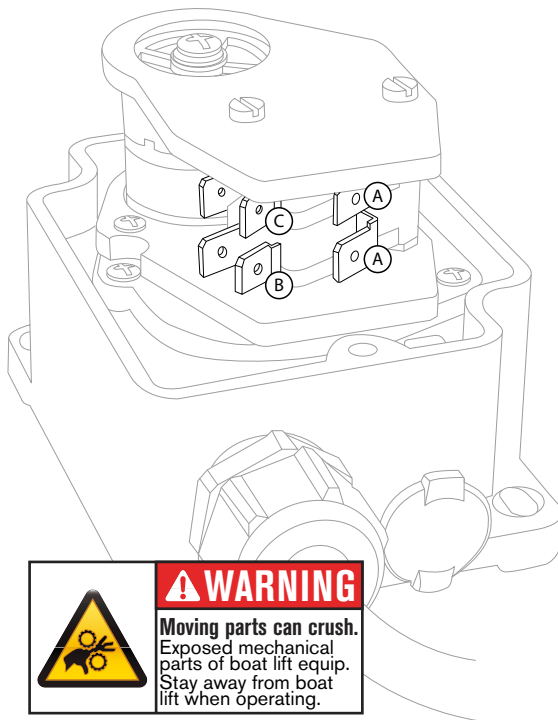
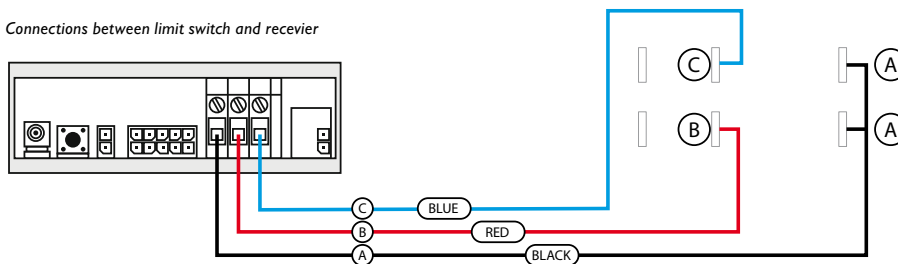

**WARNING!** It is very important that this phase of the installation is carefully thought out and performed with precision. If the micro-breakers are connected incorrectly, thus disabling them, the hoist will NOT stop at the automatic stop positions, leading to serious equipment damage as a result. For this reason, test the hoist equipment without the automatic hoisting features before installation. See "Raising/lowering the boat outside of the boat hoist's stopping positions." for information on how to do this.

**TIP:** If the boat hoist does not stop at the end position, you can remedy this by switching conductors (B) and (C) in the receiver box. This will reverse the breaker handles' functionality.



---

# Installation

## How to install the limit switch & safety stop function

**WARNING!** *This section of the manual is only for licensed electricians and installers. Interference with high-voltage equipment is illegal for individuals without the required training/authorization.*



## Mounting the limit switch into the hoist motor

The installation of the limit switch may vary depending on the type of boat hoist it is being installed on. Below are some examples.

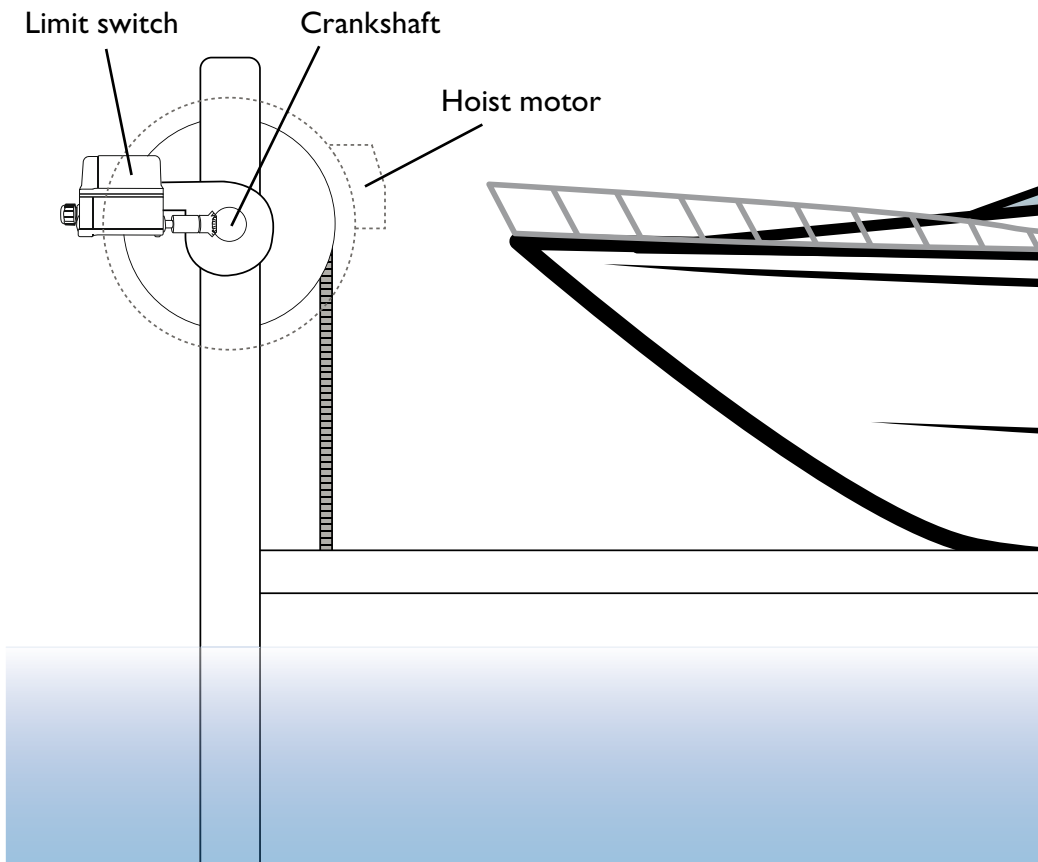

In the image, the limit switch is mounted at a 90 degree angle to the crankshaft. The motor connection's cogwheel on the limit switch is connected to a cogwheel on the boat hoist's crankshaft.

**NOTE!** *This function must be checked carefully to avoid incorrect boat hoist operation.*

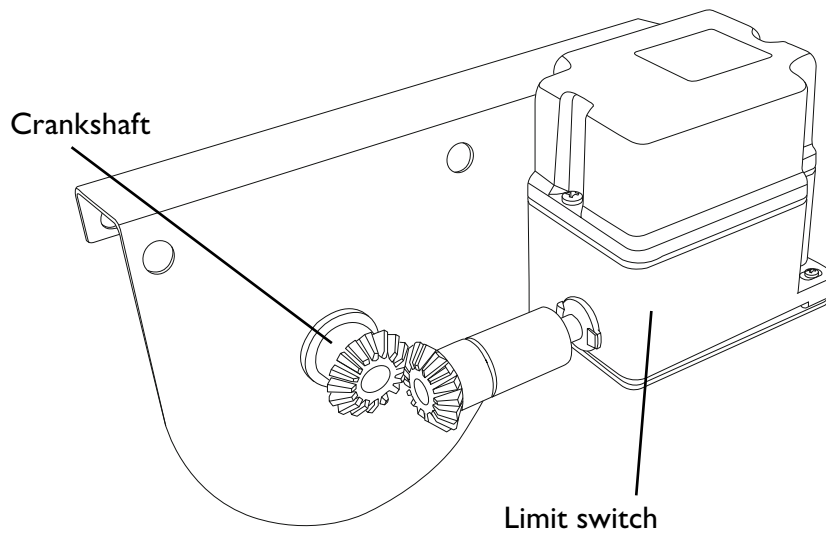
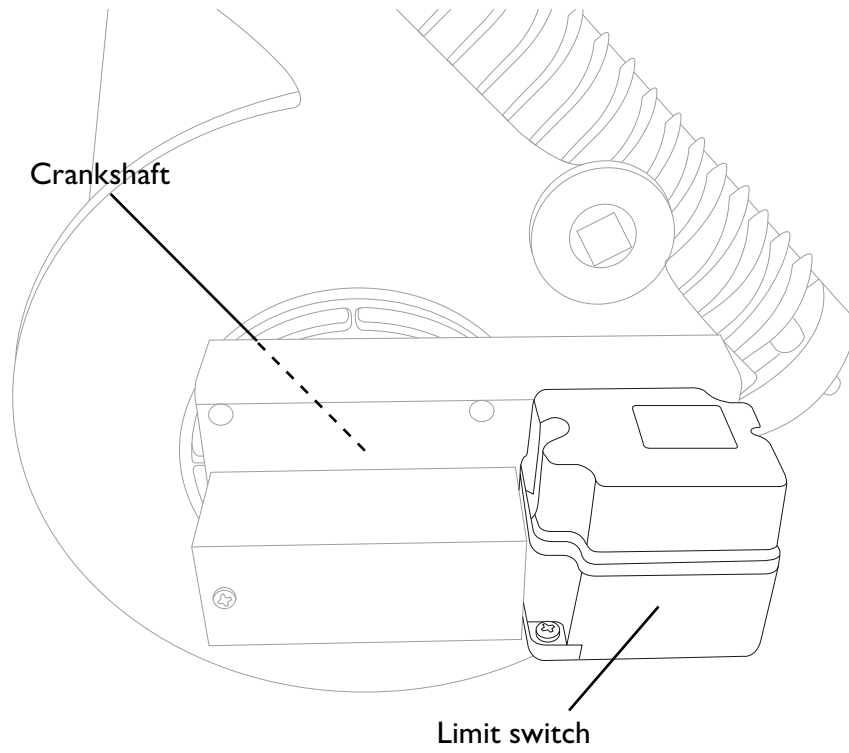

## Option 2

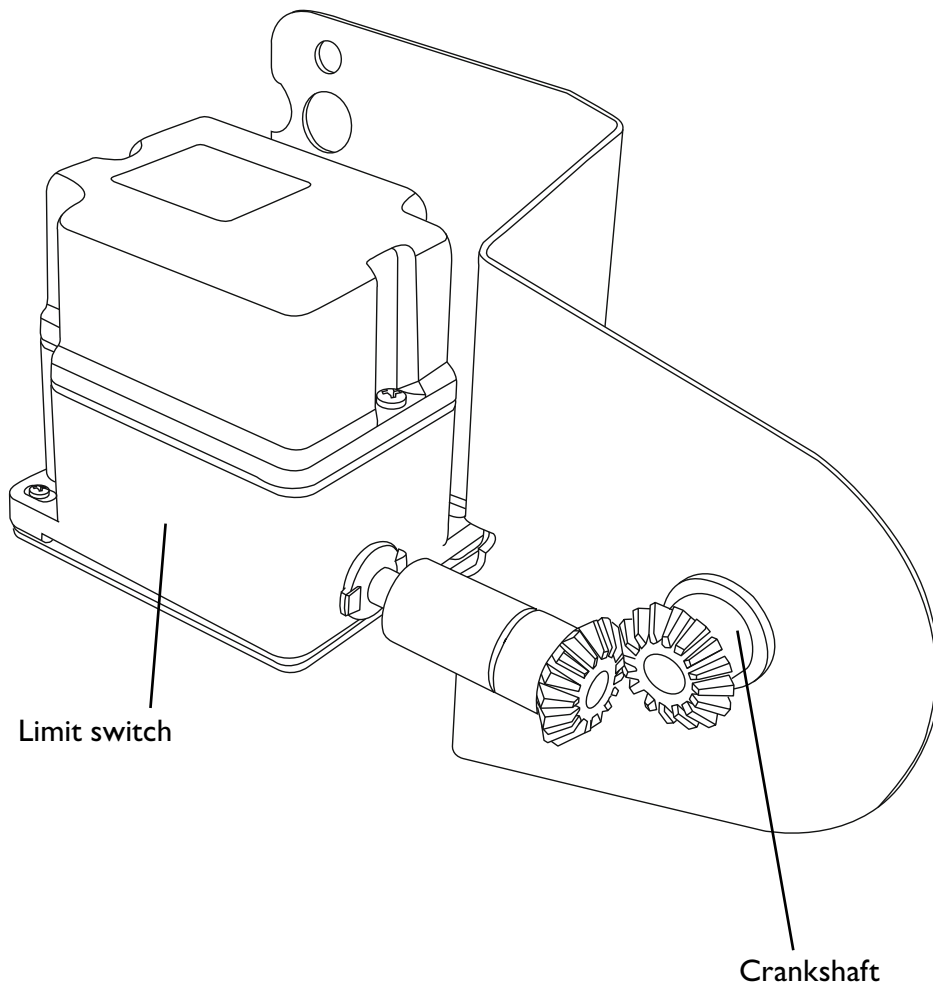

---

## Option 3

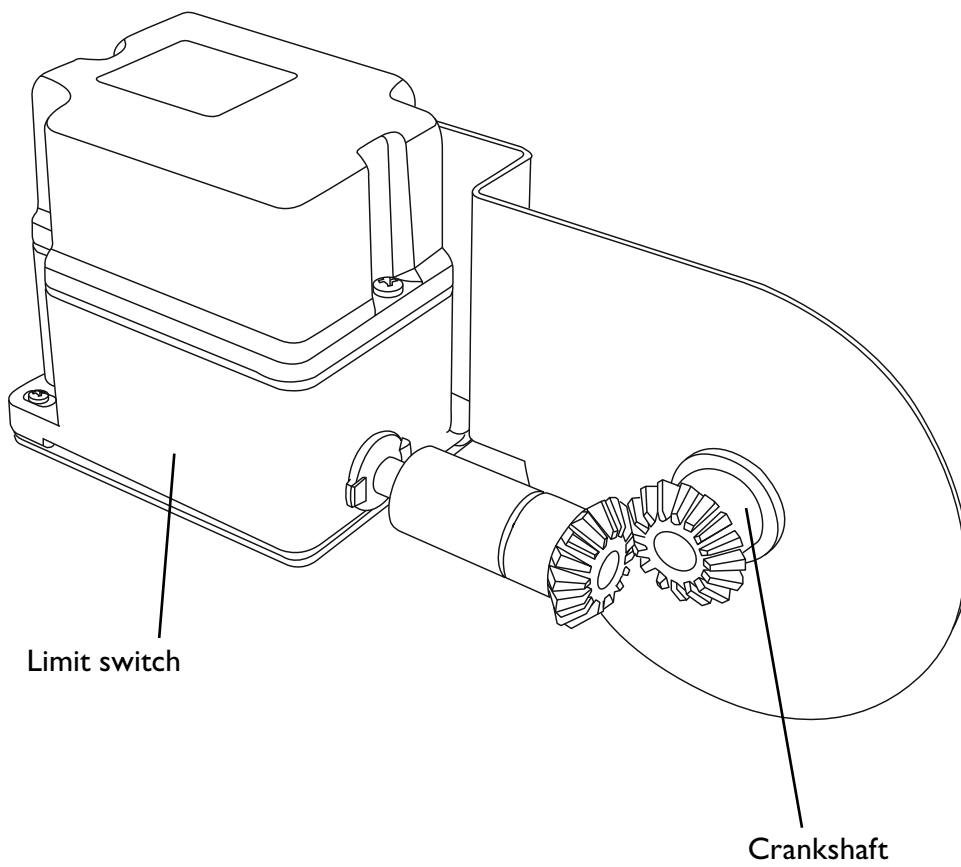

## Option 4

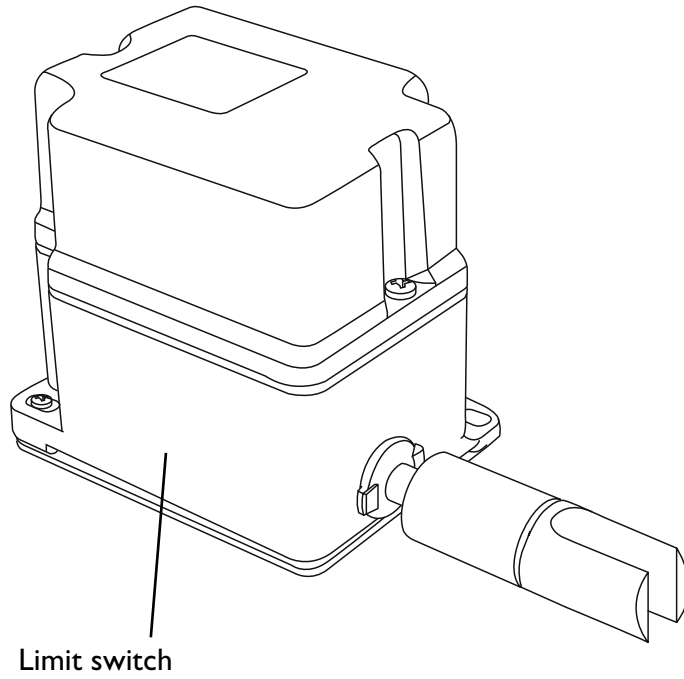

---

## SAFETY II stop function

---

The Tigershark 2.0 has many safety features as standard in order to prevent problems. In order to make the lift even more secure an added control feature can be activated called SAFETY II. To activate this feature the lift has to be installed completely and tested.

**NOTICE!** When using the SAFETY II function the lift should always be tested to verify that the programming was successful.

### Activating the SAFETY II function:

1. Run a whole lift cycle, up and down, to verify that top- and bottom end positions are at a satisfactory level.
2. Lower the lift to the bottom end position, lift should stop automatically when the limit switch perceives it has reached the bottom end position.

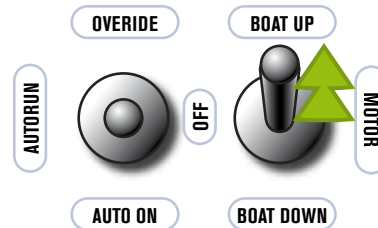
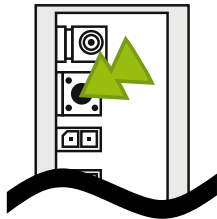

3. Press the indicated button on the receiver. The RED led will light up.

4. Immediately move the indicated control panel switch to “BOAT UP”.

5. Lift goes up, when the lift reaches the pre-programmed top end position the lift stops and the receiver stores the cycle time.
6. When the receiver stores the cycle time a yellow LED will blink in the receiver. This can be hard to see so a manual test of the SAFETY II function is recommended.

### Manual testing of the SAFETY II function:

1. Adjust the limit switch top position to a point where the lift stops higher up.
2. Lower the lift to the bottom end position.
3. Raise the lift, either manually or with the transmitter.
4. The lift should now stop before the limit switch engages.
5. Adjust the limit switch top position back to its original stop position.

# General notice

The **TigerShark** system is delivered in a 120V (1 phase 120V) version.

The reason behind this is to minimize the following if the wrong installation is performed:

- Possible transformer blowout
- Possible contactor blowout
- Possible motor destruction and or fire



---

# Installation

## How to connect hoist motors to the control panel

There are a number of different motor solutions on the market. We present the most COMMON ones here.

NOTE: Your motor MAY NOT be pictured

Read the instructions for your motor for the correct connection. Tele Radio cannot be held responsible for connections made OUTSIDE the TigerShark box.

**WARNING!** *This section of the manual is only for licensed electricians and installers. Interference with high-voltage equipment is illegal for individuals without the required training/authorization.*

**WARNING:** *Motor connections shown are to be used as a guide. We require you to contact your boat lift dealer, motor manufacturer, installer and professional electrician to double check and verify connections to your boat lift as many motors change over time.*



**Tele Radio will not be responsible for improper connections.**



## Connecting hoist motors to the control panel

**WARNING:** Motor connections shown are to be used as a guide. We require you to contact your boat lift dealer, motor manufacturer, installer and professional electrician to double check and verify connections to your boat lift as many motors change over time.

Tele Radio will not be responsible for improper connections.

Wiring symbols  = Cap     = Screw     = Pin

### Standard color coded motor

A.O. Smith, Baldor, Dayton, Electrogear, Emerson, Leeson, Lincon, Marathon and other colored motor wires.

120 V

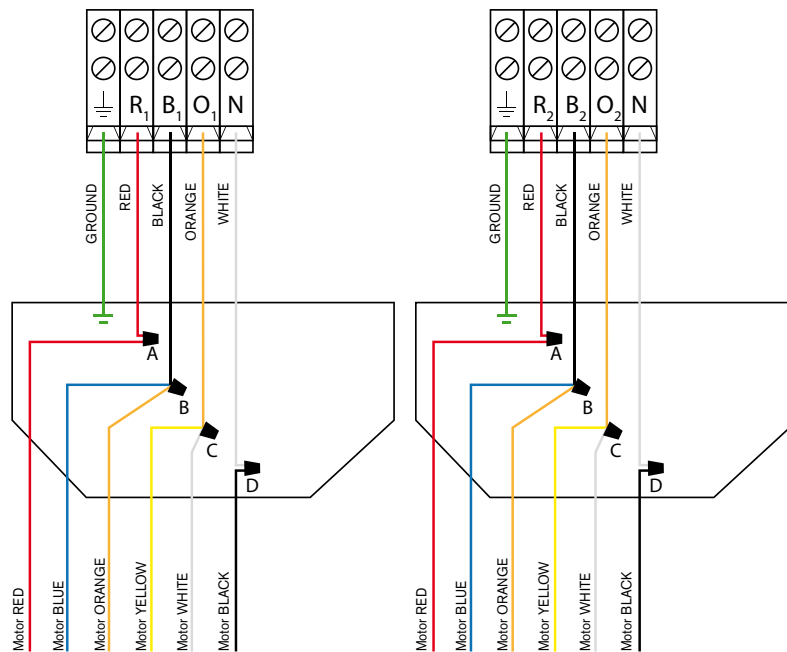

Motor 1

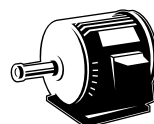

Motor 2

**TIP:** To change direction, switch MOTOR RED & BLACK.

120 V

# Changeover process

From 120 V to 230 V



230 V

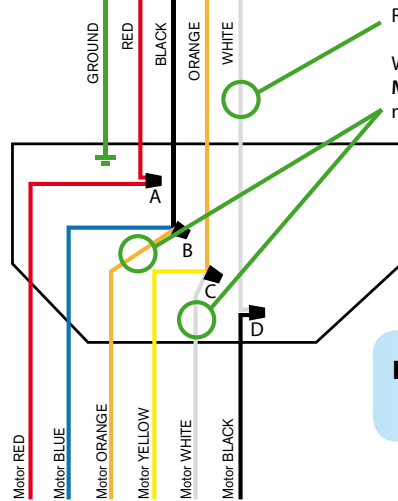
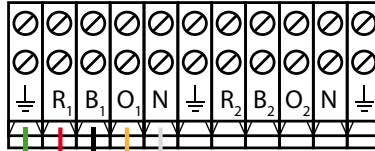

Remove TigerShark White.  
Wire together Motor ORANGE with Motor WHITE & BLACK at position marked "D".

**NOTE:** Do this change on both motors!

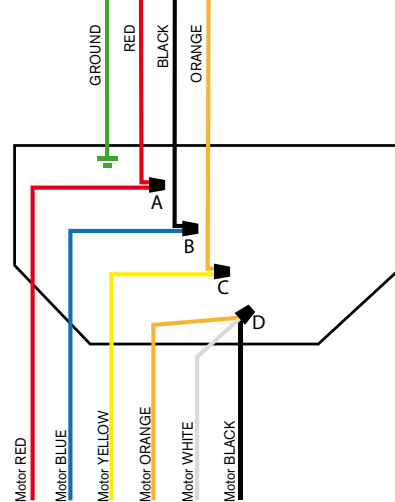
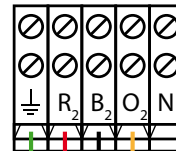
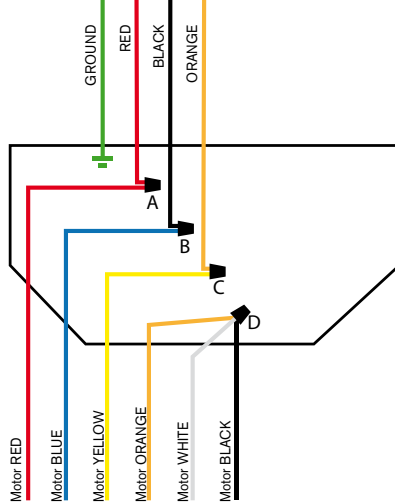
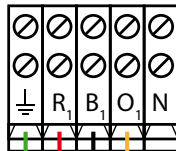

**WARNING:** Motor connections shown are to be used as a guide. We require you to contact your boat lift dealer, motor manufacturer, installer and professional electrician to double check and verify connections to your boat lift as many motors change over time.

Tele Radio will not be responsible for improper connections.

## Standard T-motor

120 V

A.O. Smith, Baldor, Dayton, Deco, GE, Electrogear, Emerson, Leeson, Lincon, Marathon, SMC and other T-numbered motor wires.

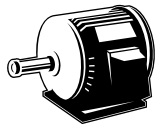
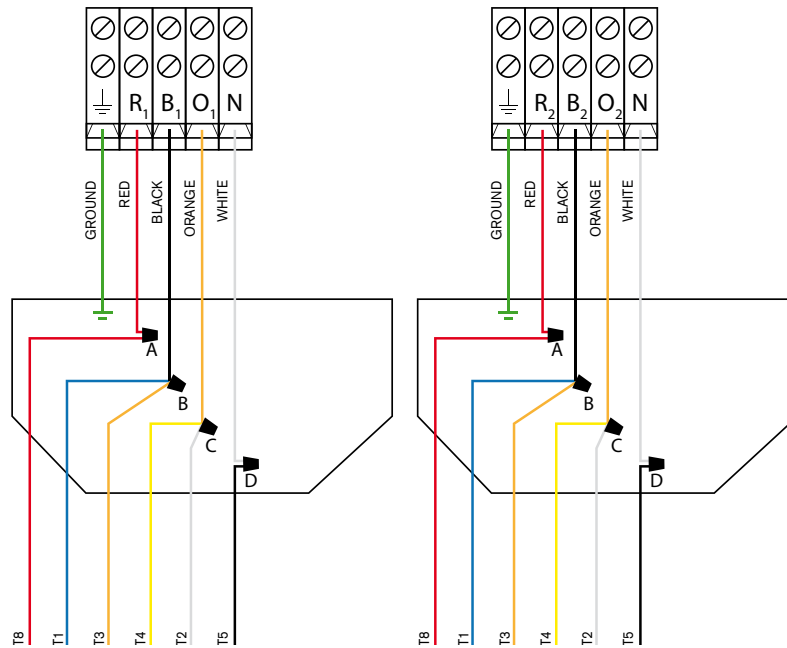

Motor 1

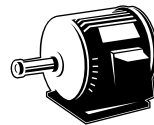

Motor 2

**TIP:** To change direction, switch T5 & T8.

120 V

# Changeover process

From 120 V to 230 V



230 V

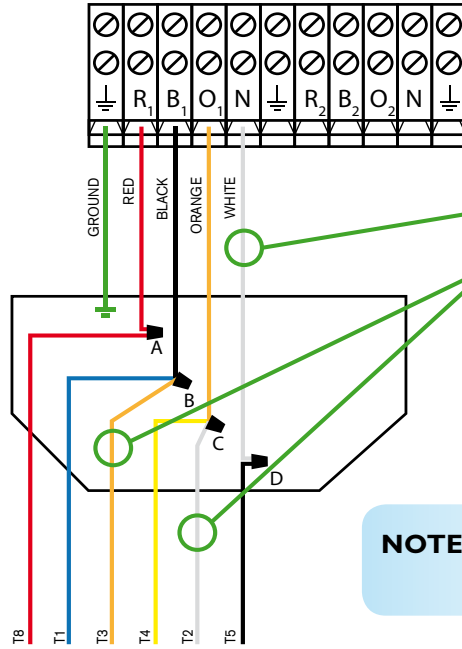

Remove TigerShark WHITE.  
Wire together Motor T3 with Motor T2 & T5 at position marked "D".

**NOTE:** Do this change on both motors!

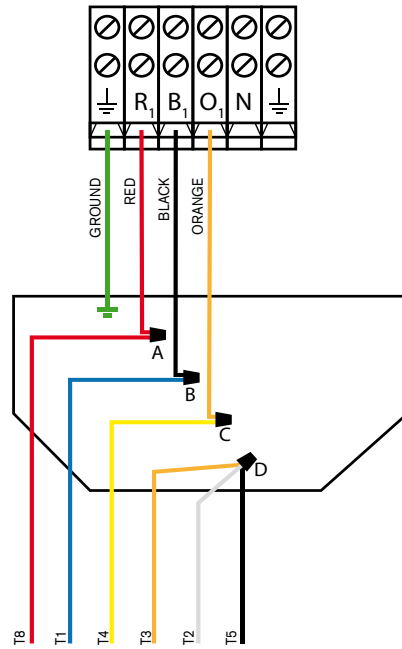
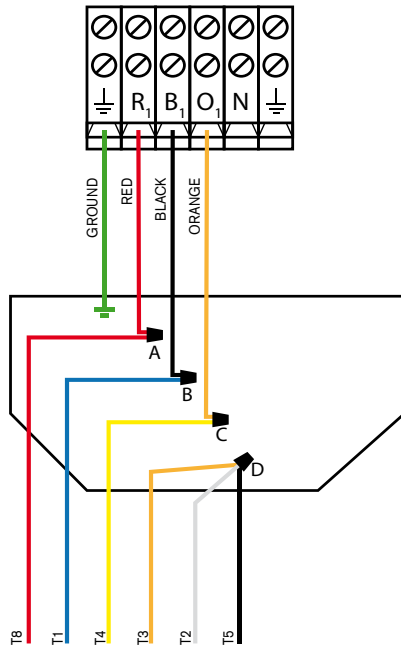

**WARNING:** Motor connections shown are to be used as a guide. We require you to contact your boat lift dealer, motor manufacturer, installer and professional electrician to double check and verify connections to your boat lift as many motors change over time.

Tele Radio will not be responsible for improper connections.

## Eastbay motor

120 V

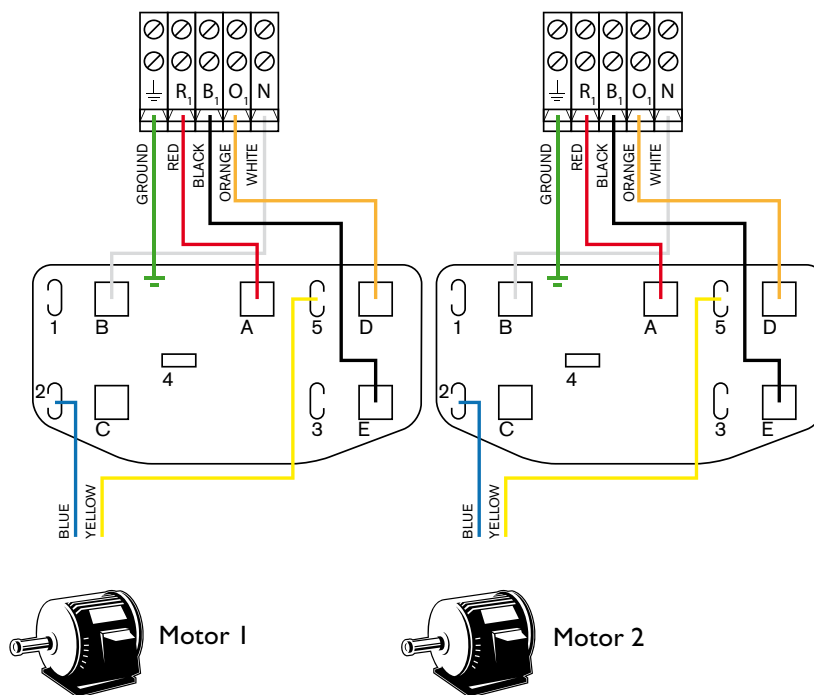

**TIP:** To change direction, switch E(RED) & D(Jumper Wire)

120 V

**Changeover process**

From 120 V to 230 V



230 V

**NOTE:** Do this change on both motors!

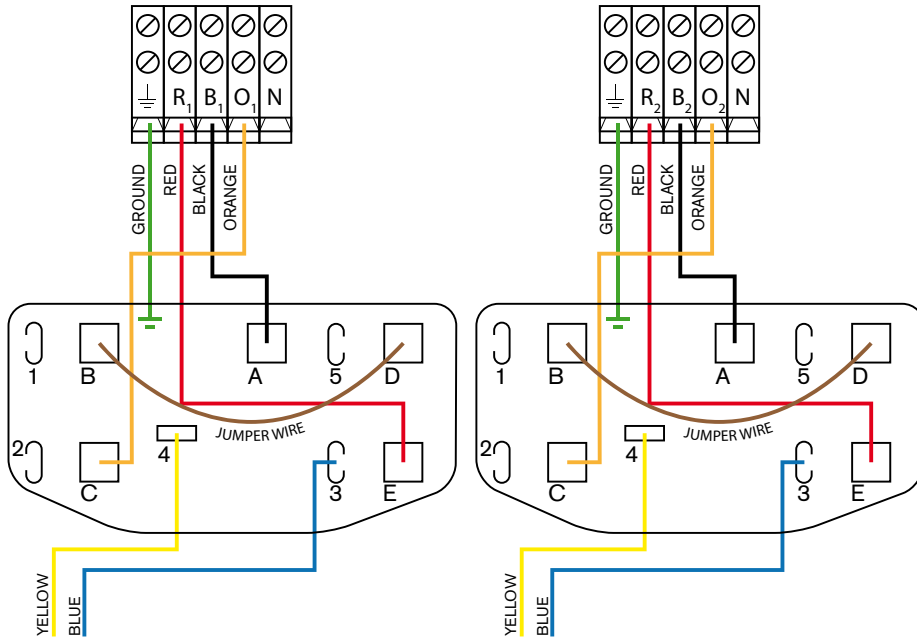
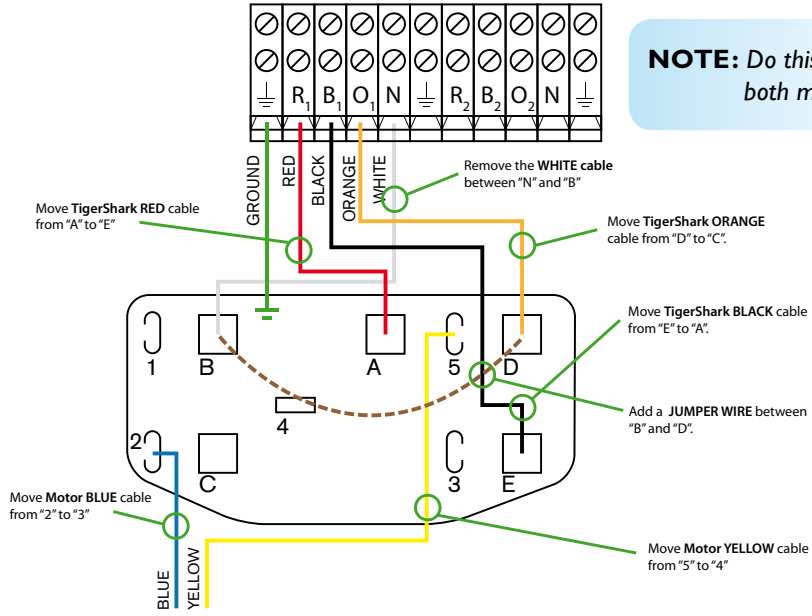

**WARNING:** Motor connections shown are to be used as a guide. We require you to contact your boat lift dealer, motor manufacturer, installer and professional electrician to double check and verify connections to your boat lift as many motors change over time.

Tele Radio will not be responsible for improper connections.

## AO Smith motor

120 V

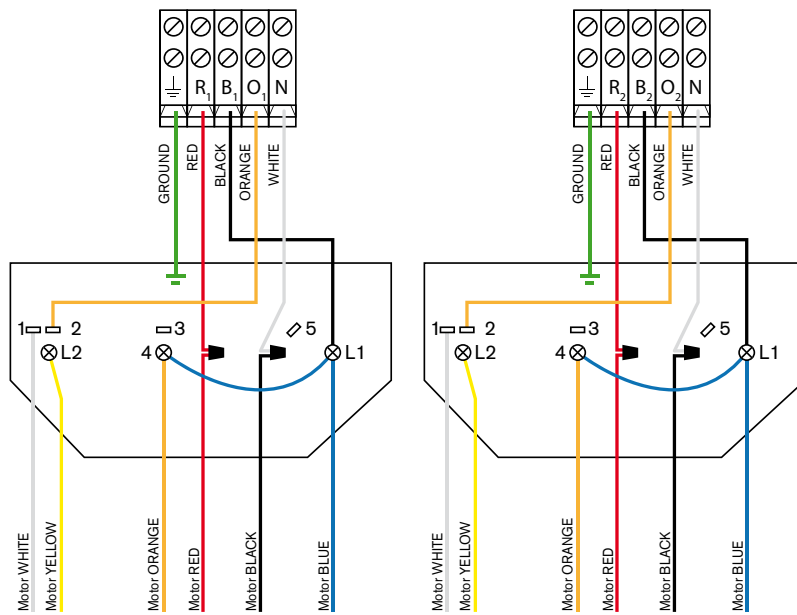

Motor 1

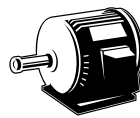

Motor 2

**TIP:** To change direction, switch MOTOR RED & BLACK.



120 V

# Changeover process

From 120 V to 230 V



230 V

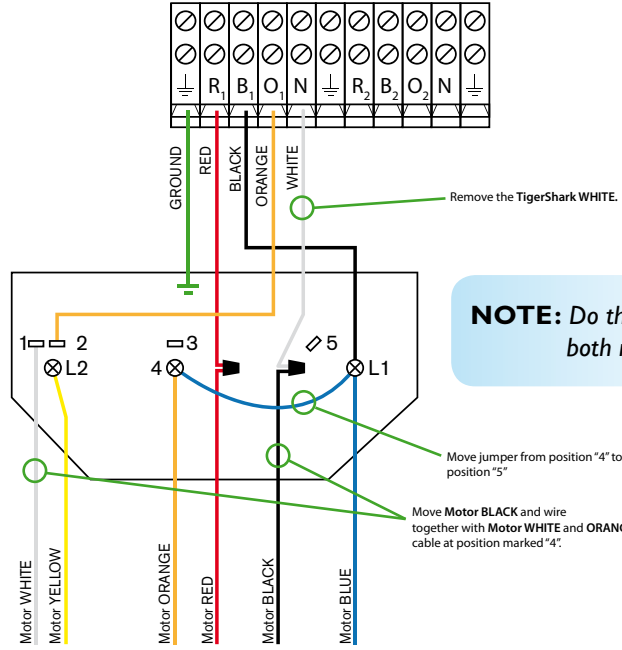

**NOTE:** Do this change on both motors!

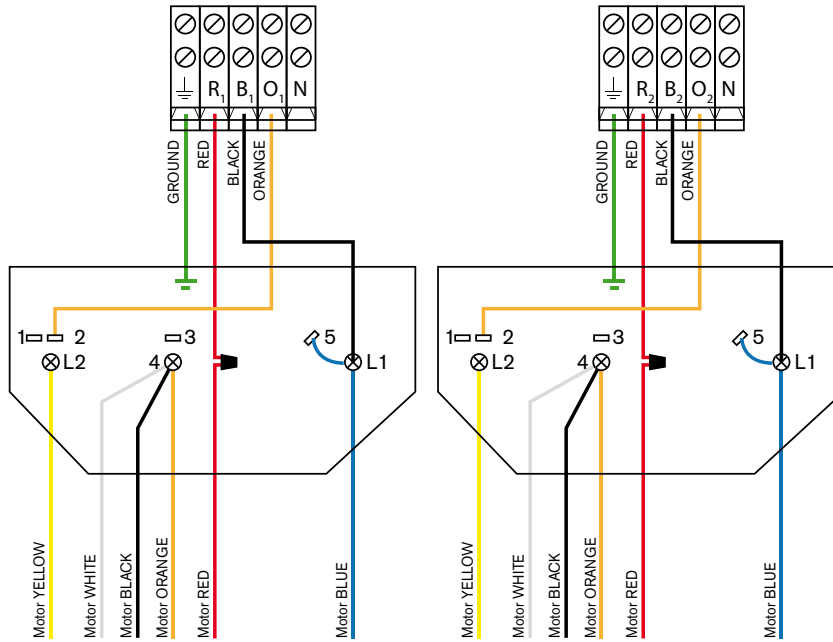

**WARNING:** Motor connections shown are to be used as a guide. We require you to contact your boat lift dealer, motor manufacturer, installer and professional electrician to double check and verify connections to your boat lift as many motors change over time.

Tele Radio will not be responsible for improper connections.

## Leeson Baldor motor

230 V

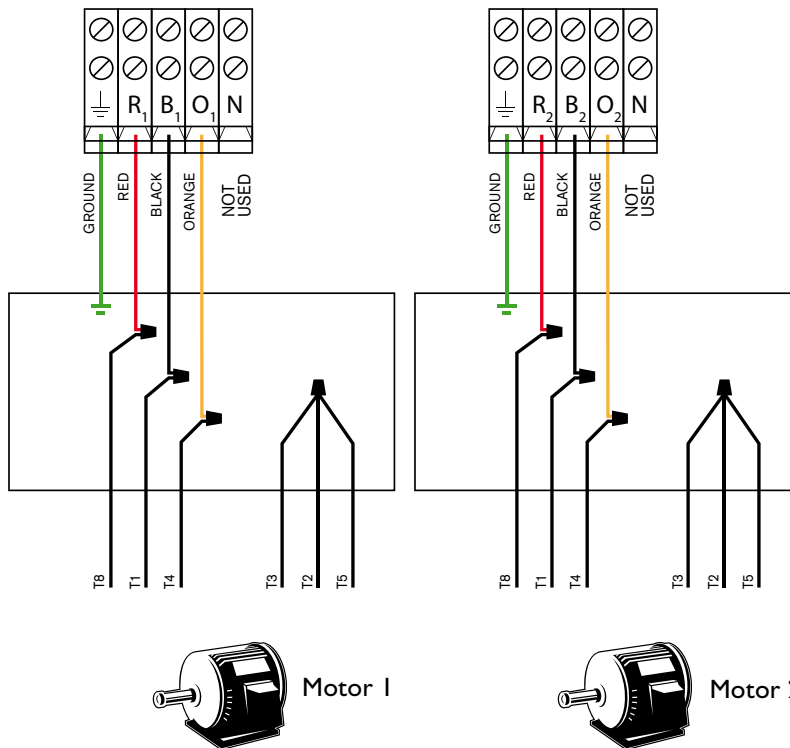

**TIP:** To change direction, switch T8 & T5.

120 V

# Changeover process

From 120 V to 230 V

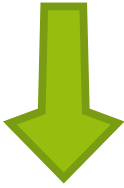

230 V

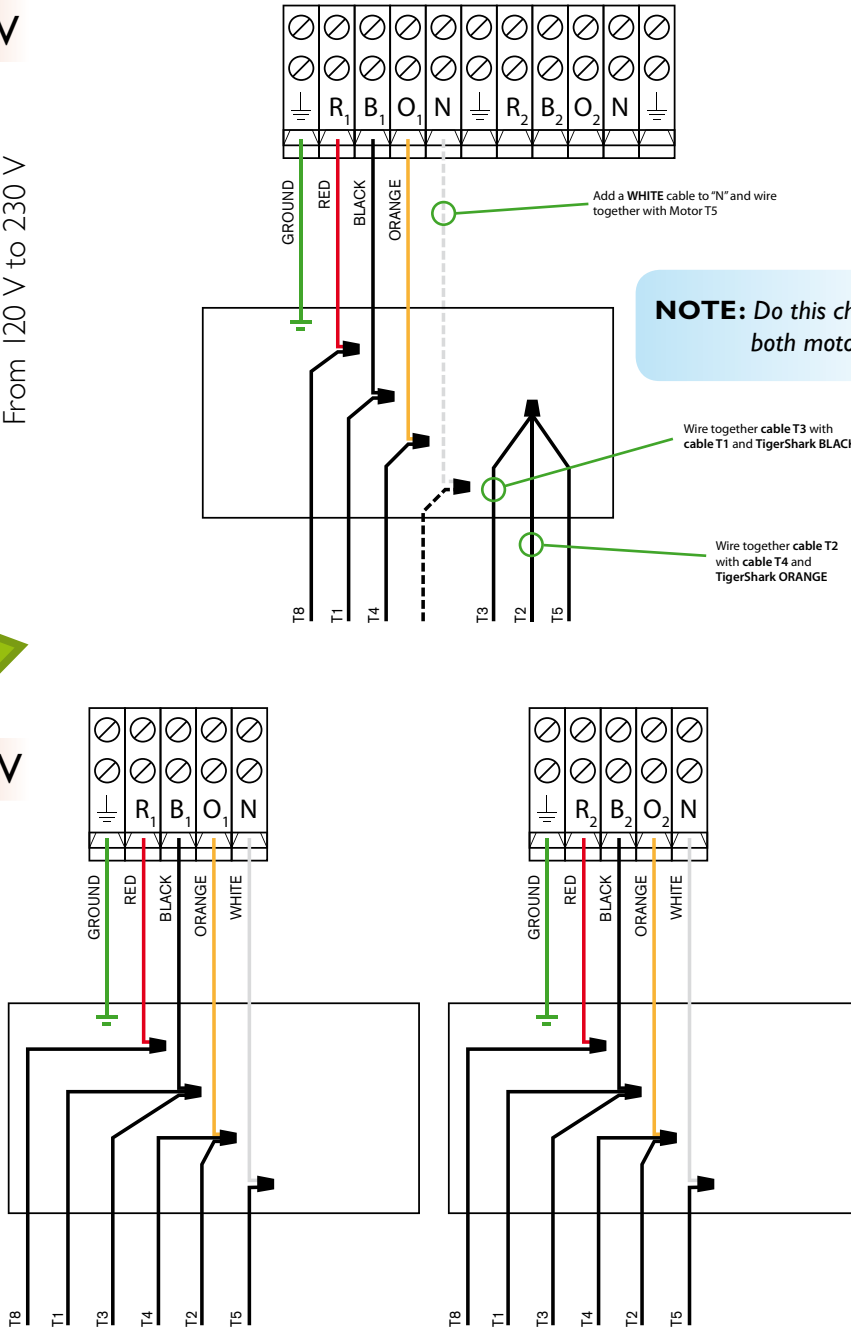

**WARNING:** Motor connections shown are to be used as a guide. We require you to contact your boat lift dealer, motor manufacturer, installer and professional electrician to double check and verify connections to your boat lift as many motors change over time.

Tele Radio will not be responsible for improper connections.

## General Electric motor

120 V

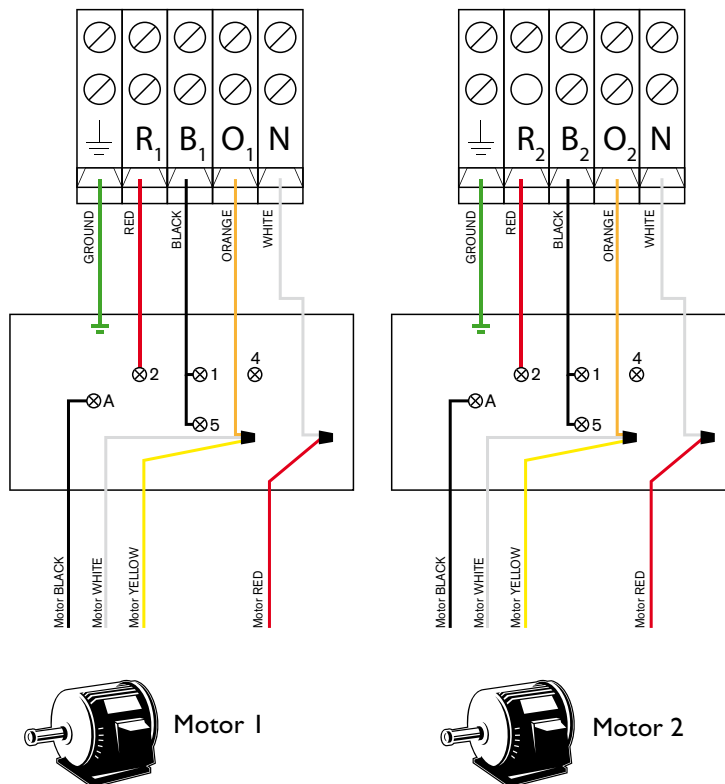

**TIP:** To change direction, switch MOTOR RED & BLACK.

120 V

# Changeover process

From 120 V to 230 V



230 V

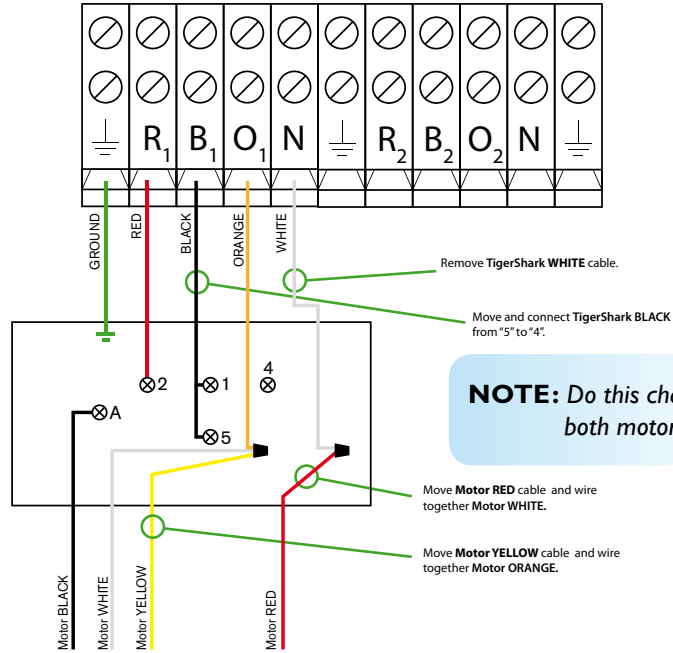

**NOTE:** Do this change on both motors!

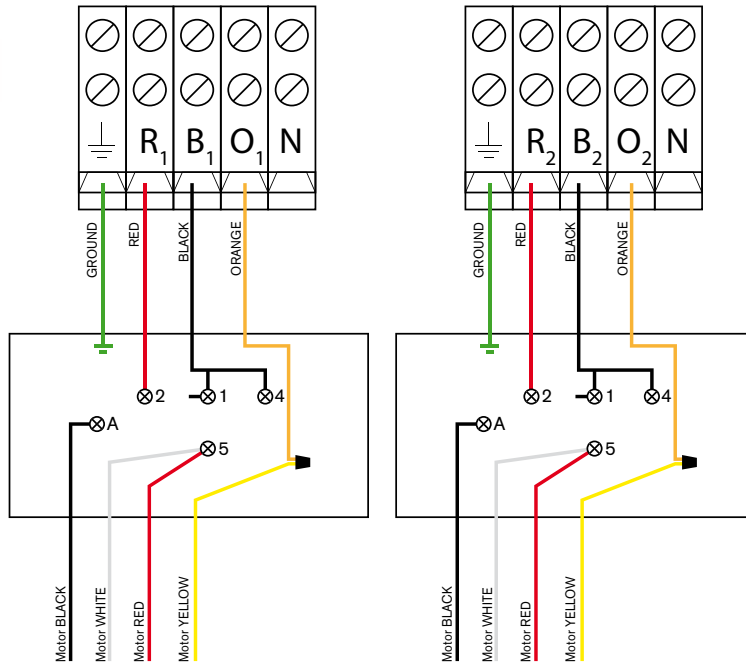

**WARNING:** Motor connections shown are to be used as a guide. We require you to contact your boat lift dealer, motor manufacturer, installer and professional electrician to double check and verify connections to your boat lift as many motors change over time.

Tele Radio will not be responsible for improper connections.

## Century Magnatech motor

120 V

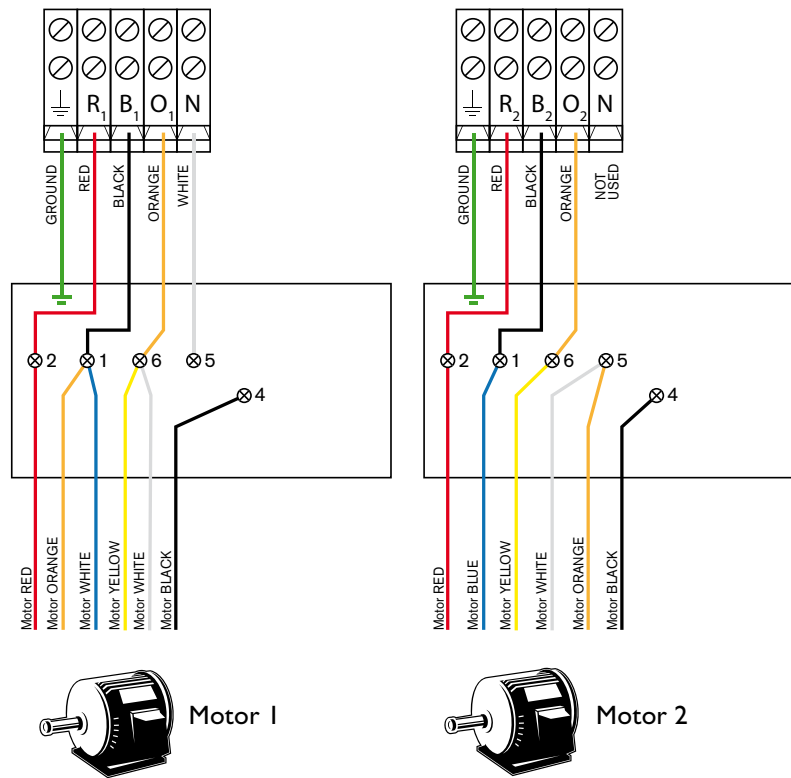

**TIP:** To change direction, switch MOTOR RED & BLACK.

120 V

# Changeover process

From 120 V to 230 V



230 V

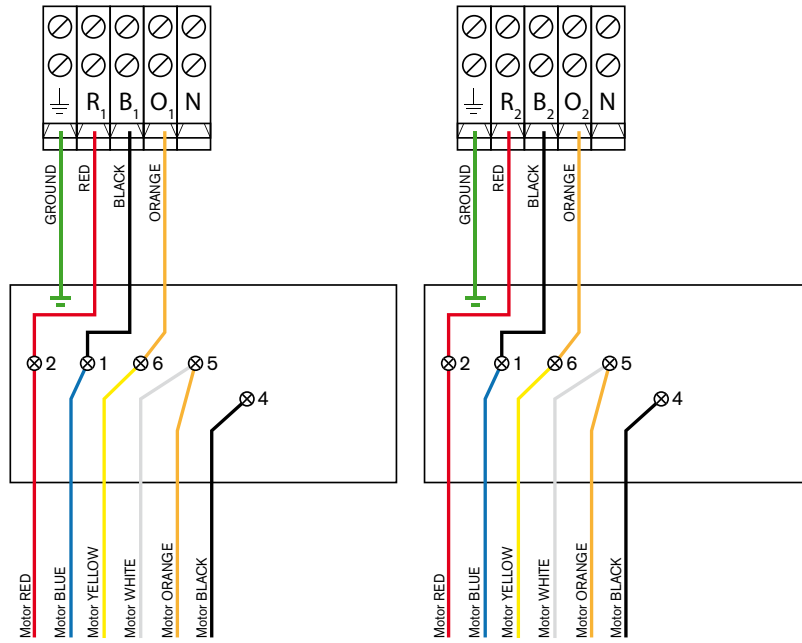
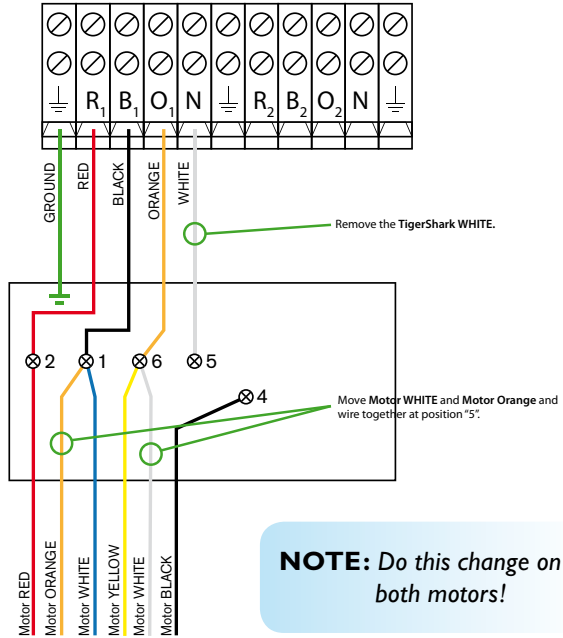

**WARNING:** Motor connections shown are to be used as a guide. We require you to contact your boat lift dealer, motor manufacturer, installer and professional electrician to double check and verify connections to your boat lift as many motors change over time.

Tele Radio will not be responsible for improper connections.

## Emerson motor

120 V

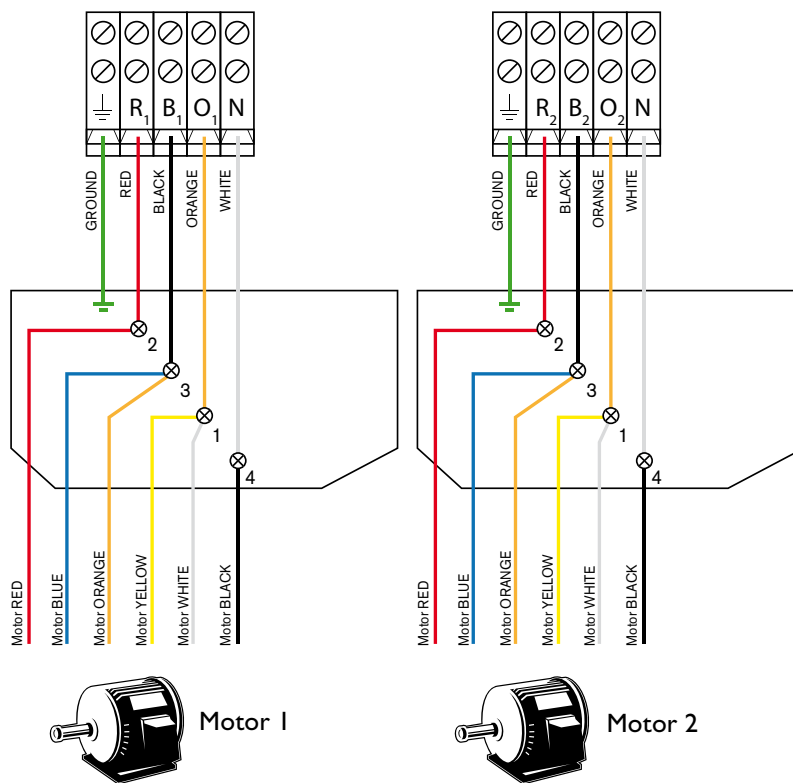

**TIP:** To change direction, switch MOTOR RED & BLACK.



120 V

# Changeover process

From 230 V to 120 V



230 V

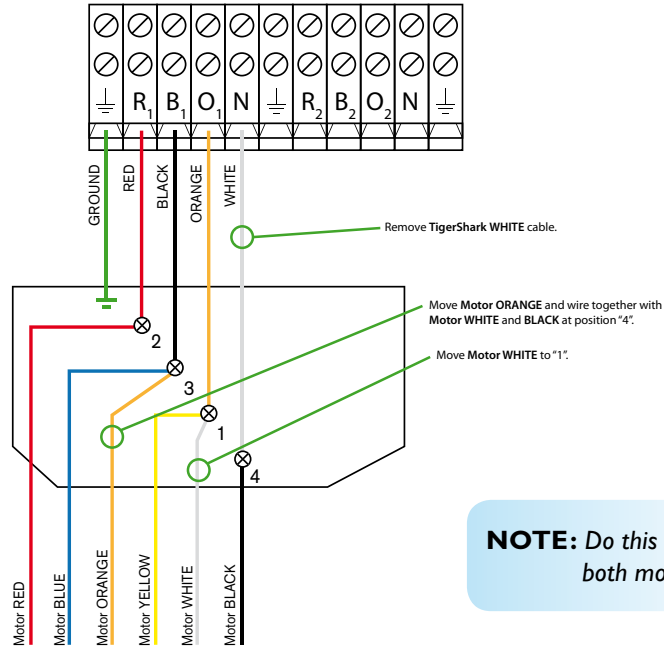

**NOTE:** Do this change on both motors!

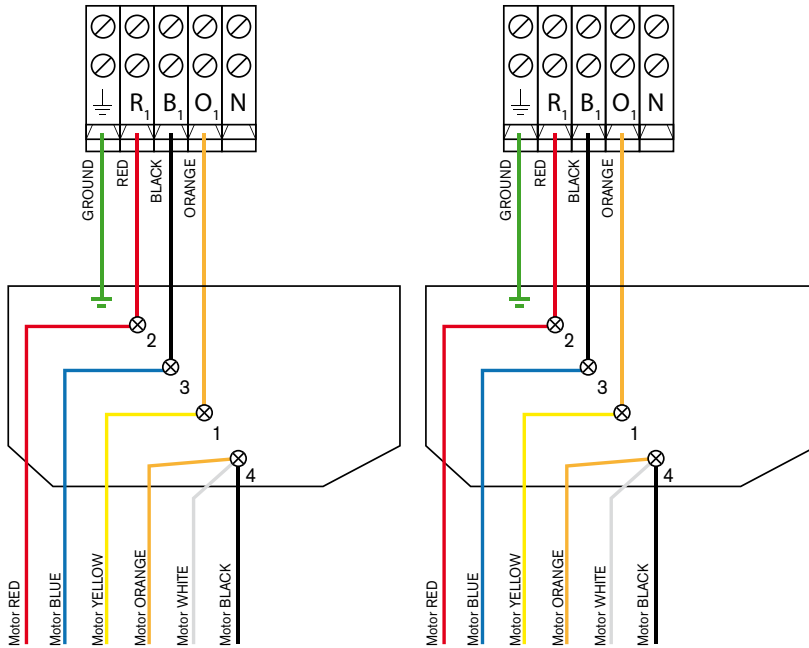

**WARNING:** Motor connections shown are to be used as a guide. We require you to contact your boat lift dealer, motor manufacturer, installer and professional electrician to double check and verify connections to your boat lift as many motors change over time.

Tele Radio will not be responsible for improper connections.

## Leeson motor

120 V

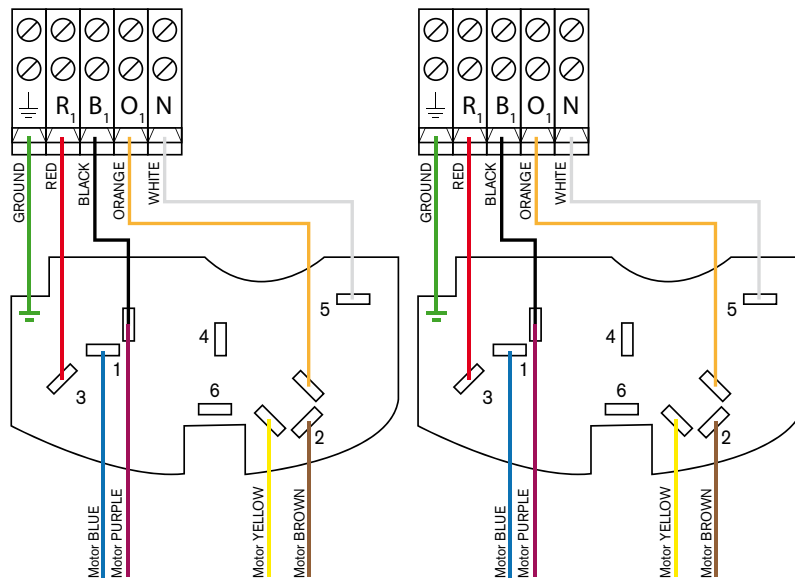

**TIP:** To change direction, switch ORANGE & BLACK.

120 V

# Changeover process

From 230 V to 120 V

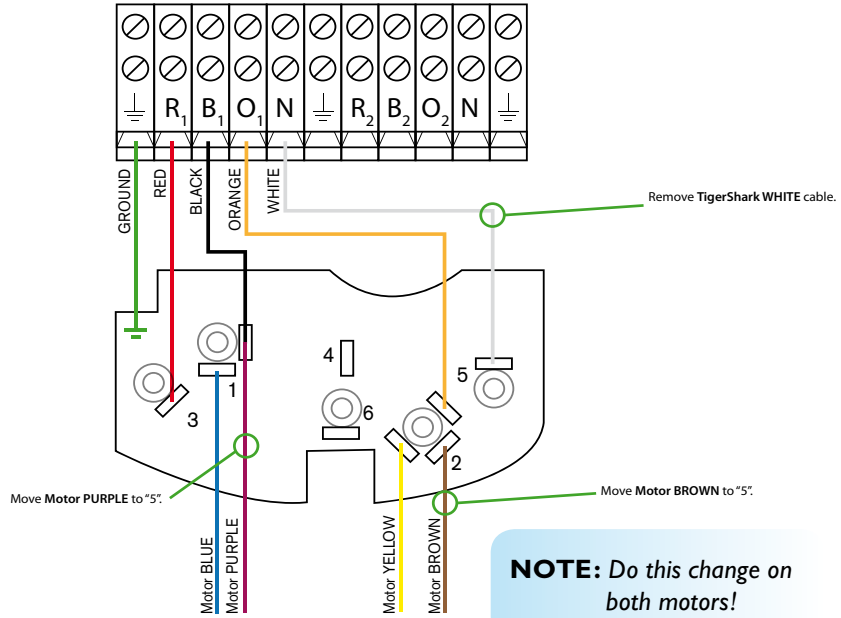

230 V

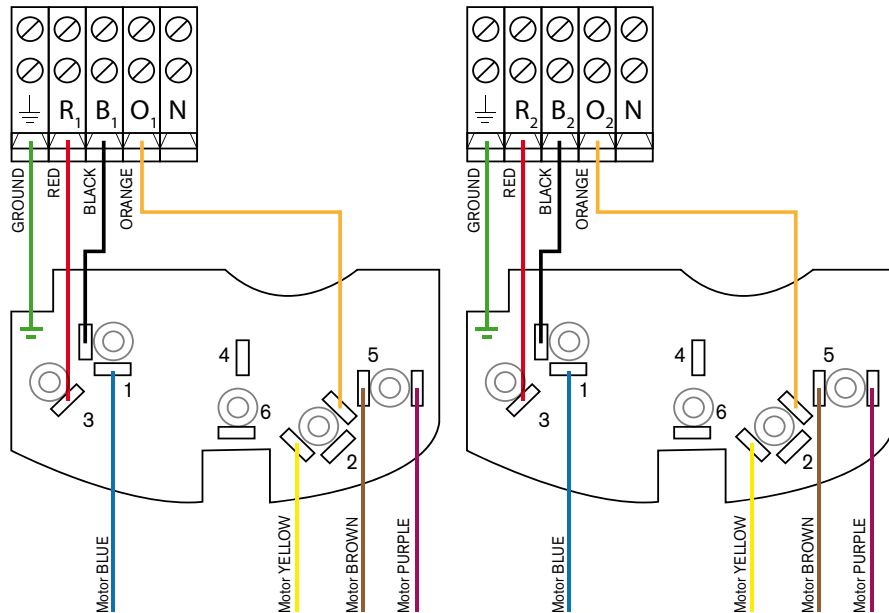

**WARNING:** Motor connections shown are to be used as a guide. We require you to contact your boat lift dealer, motor manufacturer, installer and professional electrician to double check and verify connections to your boat lift as many motors change over time.

Tele Radio will not be responsible for improper connections.

## Baldor motor

120 V

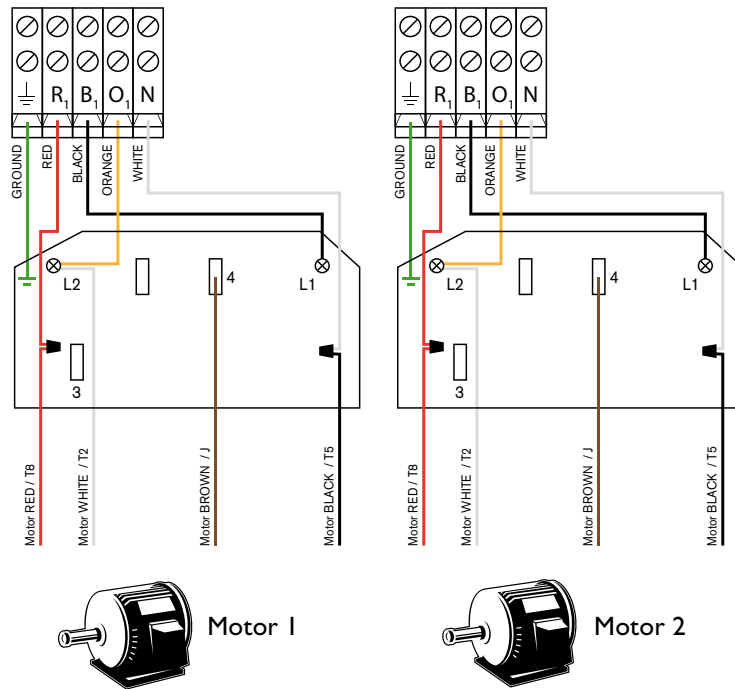

**TIP:** To change direction, switch Motor RED / T8 and Motor BLACK / T5

120 V

# Changeover process

From 230 V to 120 V



230 V

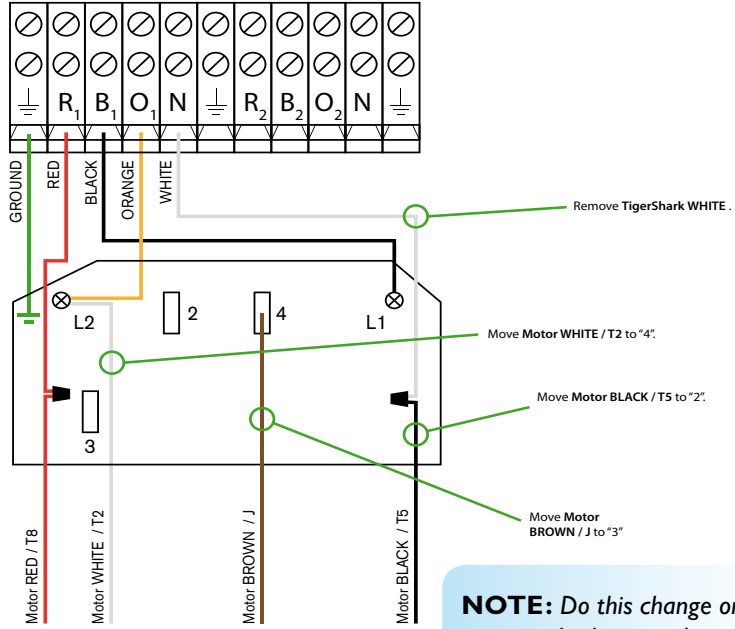
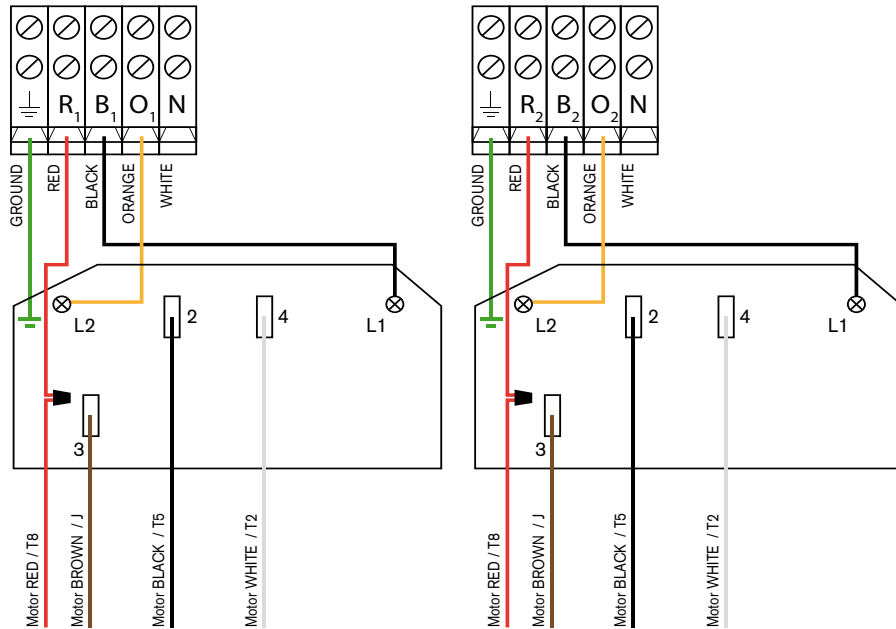

**NOTE:** Do this change on both motors!

# Appendix

## 2-motor lifts

Internal connection schematic and wiring charts

Your TigerShark unit has been delivered how it appears on the following page (Delivery design). Before connecting power you **must** first determine what AC voltage your boat lift requires and then proceed to change the wiring accordingly. In the following pages you will find all the different voltages that can be available at your location. Contact your boat lift manufacturer for further assistance.

**WARNING!** *This section of the manual is only for licensed electricians and installers. Interference with high-voltage equipment is illegal for individuals without the required training/authorization.*



## Connection schematics

### Delivery design US 120 VAC (1 phase, 120 VAC)

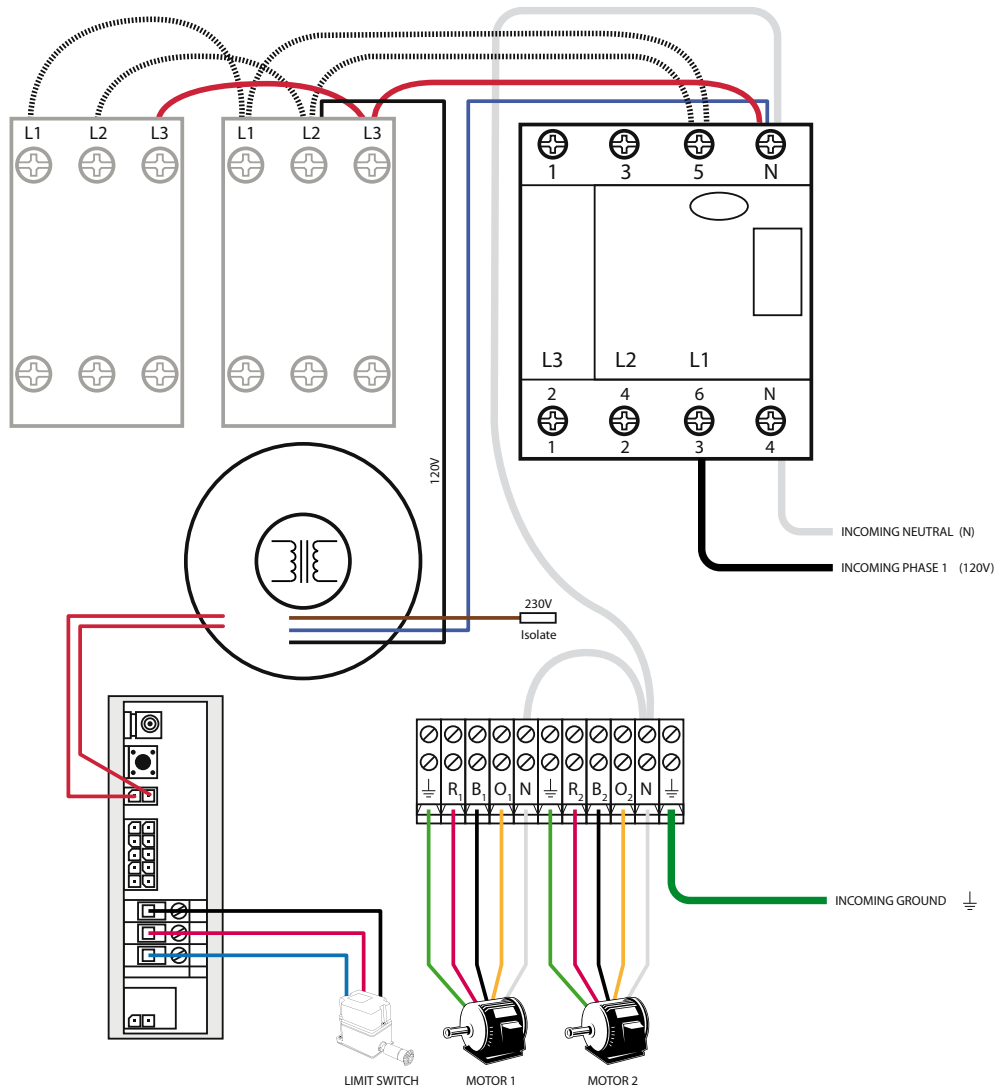
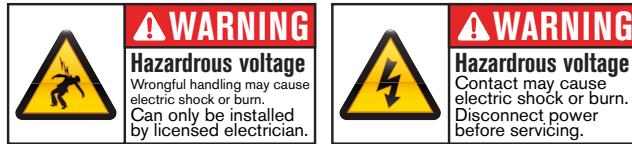

## Change instructions

Delivery design, **US 120 VAC** -> **US 230 VAC** (2 phase, 120 VAC)

Move the red conductor to position "3".

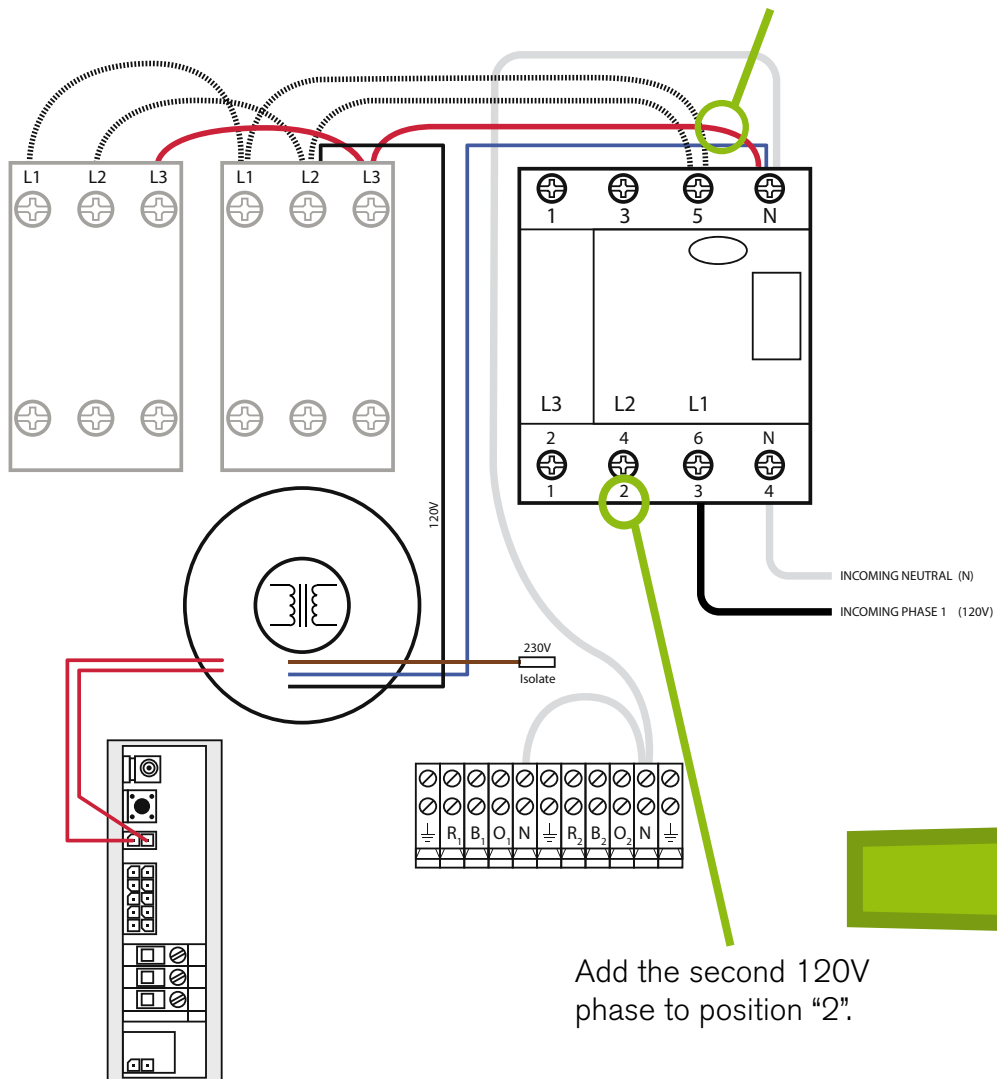



## Connection schematic

US 230 VAC  
(2 phase, 120 VAC)

	<p><b>⚠ WARNING</b> <b>Hazardous voltage</b> Wrongful handling may cause electric shock or burn. Can only be installed by licensed electrician.</p>		<p><b>⚠ WARNING</b> <b>Hazardous voltage</b> Contact may cause electric shock or burn. Disconnect power before servicing.</p>
---	---	--	---

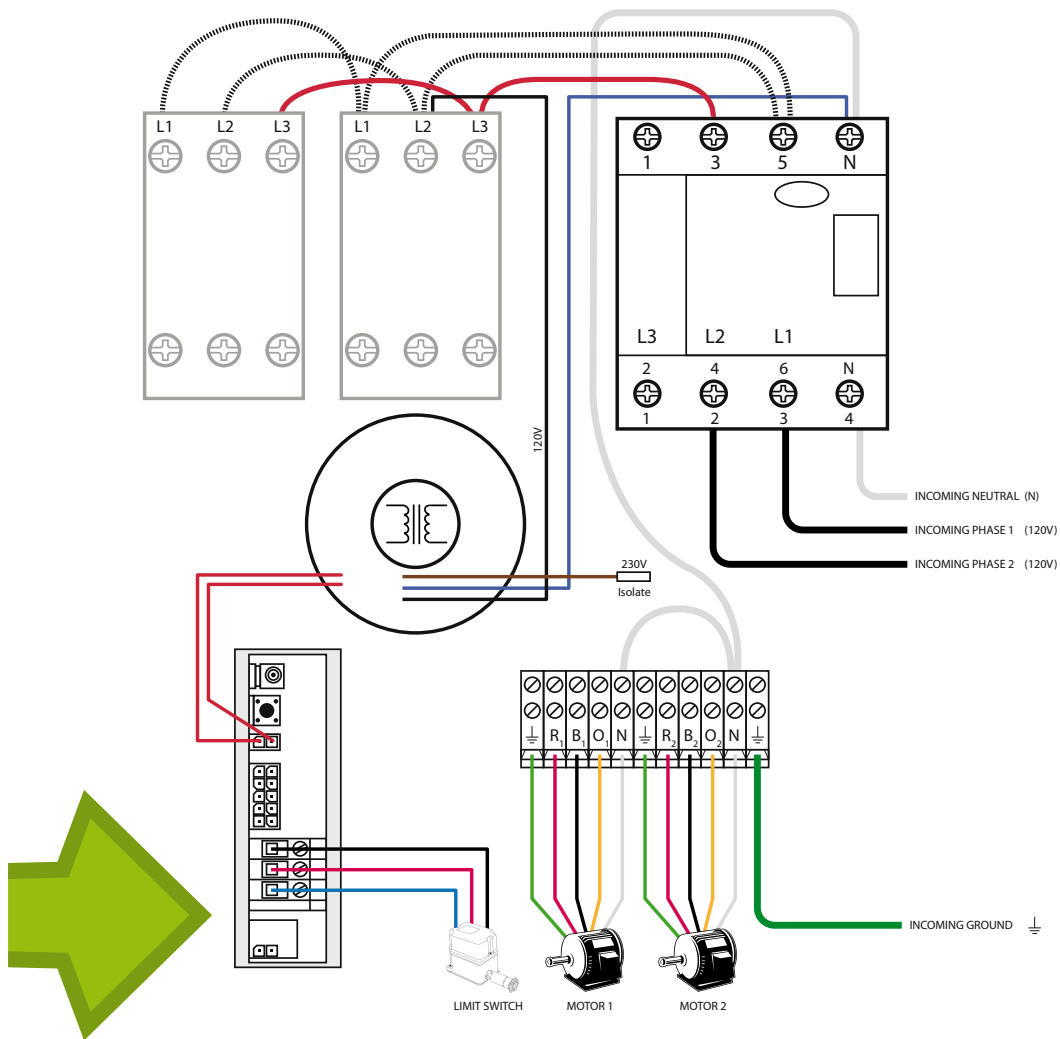

## Change instructions

Delivery design **US 120 VAC** -> 1 phase, 230 VAC

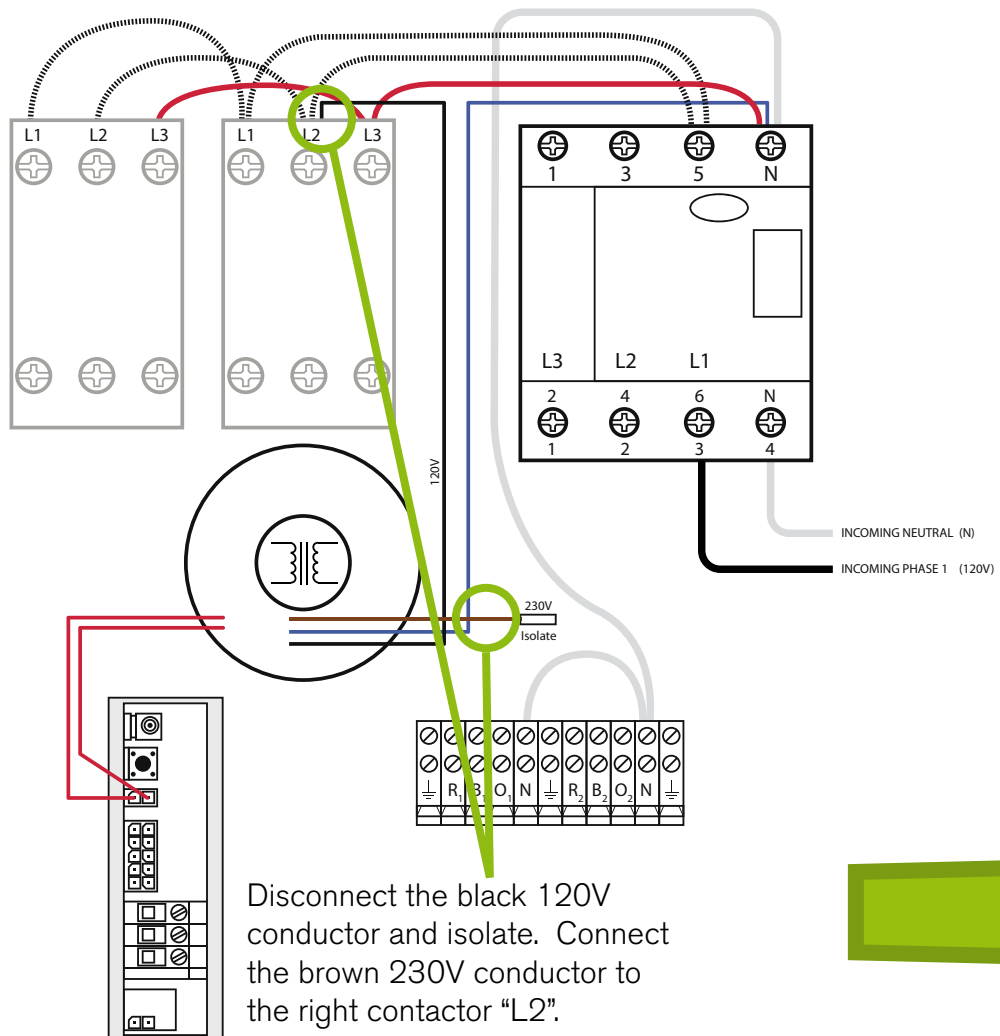

# Connection schematic

1 phase, 230 VAC

	<b>⚠ WARNING</b> <b>Hazardous voltage</b> Wrongful handling may cause electric shock or burn. Can only be installed by licensed electrician.
	<b>⚠ WARNING</b> <b>Hazardous voltage</b> Contact may cause electric shock or burn. Disconnect power before servicing.

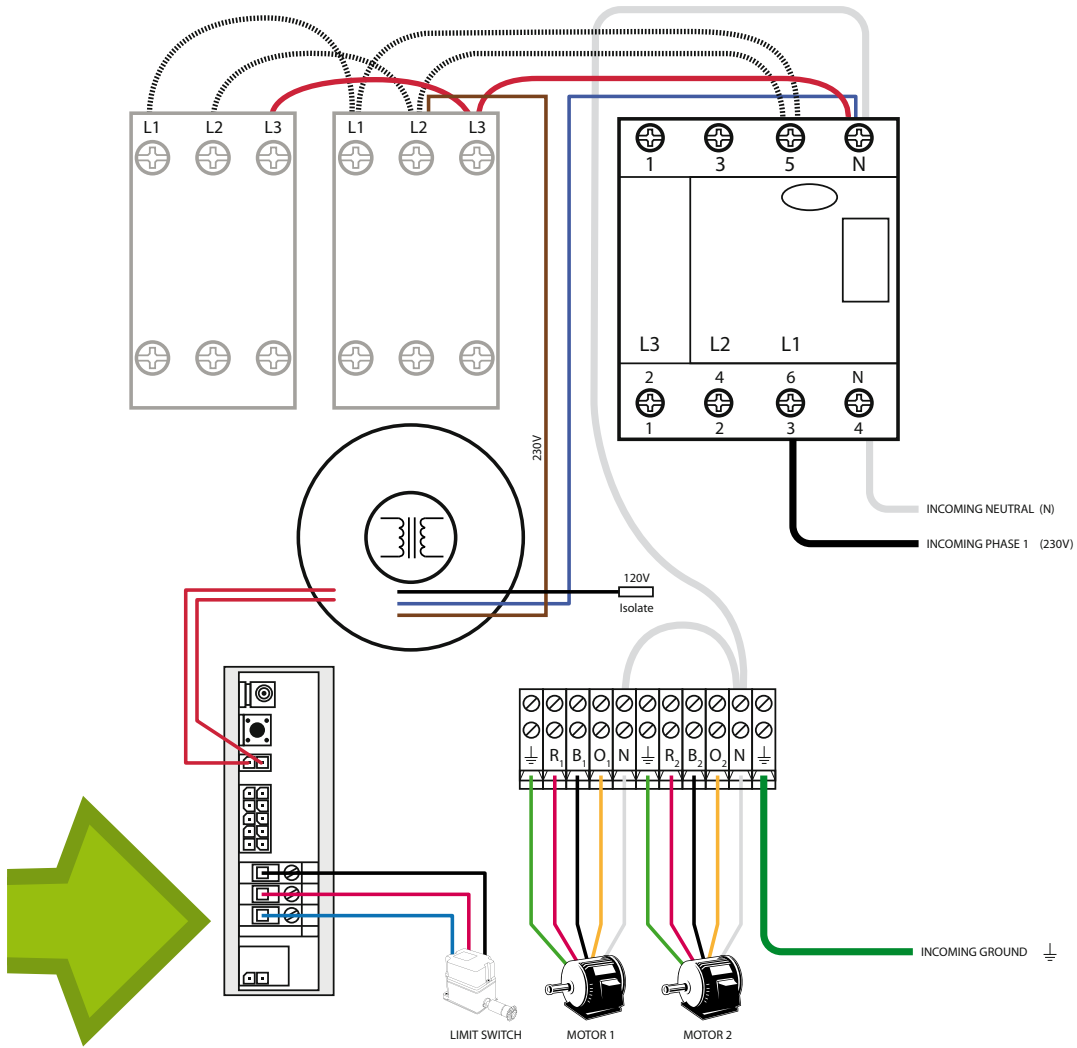

PAGE INTENTIONALLY LEFT BLANK



PAGE INTENTIONALLY LEFT BLANK



## Wire size recommendation chart

**WARNING!** Use the below chart for proper wire size. Using the wrong sized wires might damage your motors and the TigerShark unit.

### 120 V AC - 1 phase

Motor HP	# Motors	Breaker size (actual current)	15 m 50 feet	30 m 100 feet	60 m 200 feet	90 m 300 feet	120 m 400 feet
½	1	<b>10A (8,8A)</b>	12	10	6	4	4
	2	<b>20A (17,6A)</b>	10	6	4	2	1
¾	1	<b>15A (10,8A)</b>	12	8	6	4	3
	2	<b>25A (21,6A)</b>	8	6	3	1	-
1	1	<b>15A (12,8A)</b>	10	8	6	4	3
	2	<b>30A (25,6A)</b>	8	4	2	1	-
1-½	1	<b>20A (17,1A)</b>	10	6	4	2	1
	2	<b>35A (34,4A)</b>	6	4	1	-	-

## 230 V AC - 2 phase

Motor HP	# Motors	Breaker size (actual current)	15 m 50 feet	30 m 100 feet	60 m 200 feet	90 m 300 feet	120 m 400 feet	240 m 800 feet
½	1	<b>5A</b> (4,4A)	14	14	12	10	10	6
	2	<b>10A</b> (5,4A)	12	12	10	8	6	3
	4	<b>20A</b> (17,6A)	12	10	6	4	4	2
¾	1	<b>10A</b> (5,4A)	14	13	12	12	10	6
	2	<b>15A</b> (10,8A)	12	12	10	8	6	3
	4	<b>25A</b> (21,3A)	12	8	6	4	3	1
1	1	<b>10A</b> (6,4A)	14	14	12	12	10	6
	2	<b>15A</b> (12,8A)	12	10	8	6	4	1
	4	<b>30A</b> (26,0A)	10	8	4	3	2	1
1-½	1	<b>10A</b> (8,5A)	14	14	10	10	8	4
	2	<b>20A</b> (17,0A)	12	10	8	4	2	1
	4	<b>40A</b> (36,1A)	10	6	4	2	1	1/0
2	4	<b>45A</b> (44,8A)	8	6	3	1	1/0	-

## Pairing a transmitter to the TigerShark

Situations might arise where you want to add a transmitter to the TigerShark boat lift (i.e. if you have lost a transmitter or you want to add another transmitter).

Pairing a transmitter (performed in the TigerShark control box and with a transmitter)

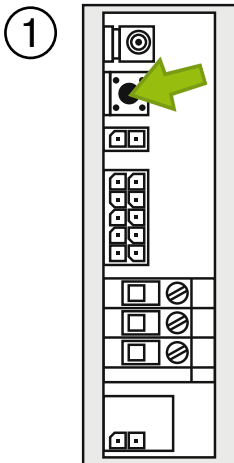

Press and hold the learn button for about a second. The RED led inside should turn on.

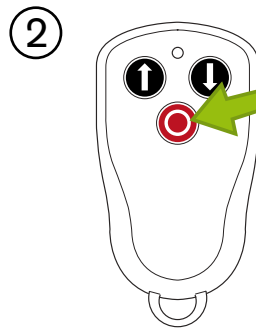

Press the red button on the transmitter.

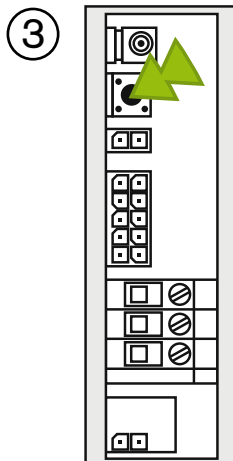

The RED led inside will flash three times. The pairing process is complete.



---

## Deleting transmitters for the TigerShark

---

Situations might arise where you want to add a delete all the transmitters for the TigerShark boat lift.

Deleting transmitters (performed in the TigerShark control box and with a transmitter)

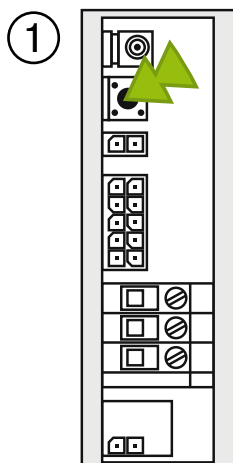

Locate the radio unit in the box. Press and hold the learn button for about six seconds. The RED led inside should turn off.

All the transmitters are now removed from memory.

# Appendix

## 4-motor lifts

Internal connection schematic and  
wiring charts

Your TigerShark unit has been delivered how it appears on the following page (Delivery design). Before connecting power you **must** first determine what AC voltage your boat lift requires and then proceed to change the wiring accordingly. In the following pages you will find all the different voltages that can be available at your location. Contact your boat lift manufacturer for further assistance.

**WARNING!** *This section of the manual is only for licensed electricians and installers. Interference with high-voltage equipment is illegal for individuals without the required training/authorization.*



## Connection schematics

**230 VAC**  
(2 phase, 120 VAC)



Before connecting power you **must** first determine what AC voltage your boat lift requires. Contact your boat lift manufacturer for further assistance.

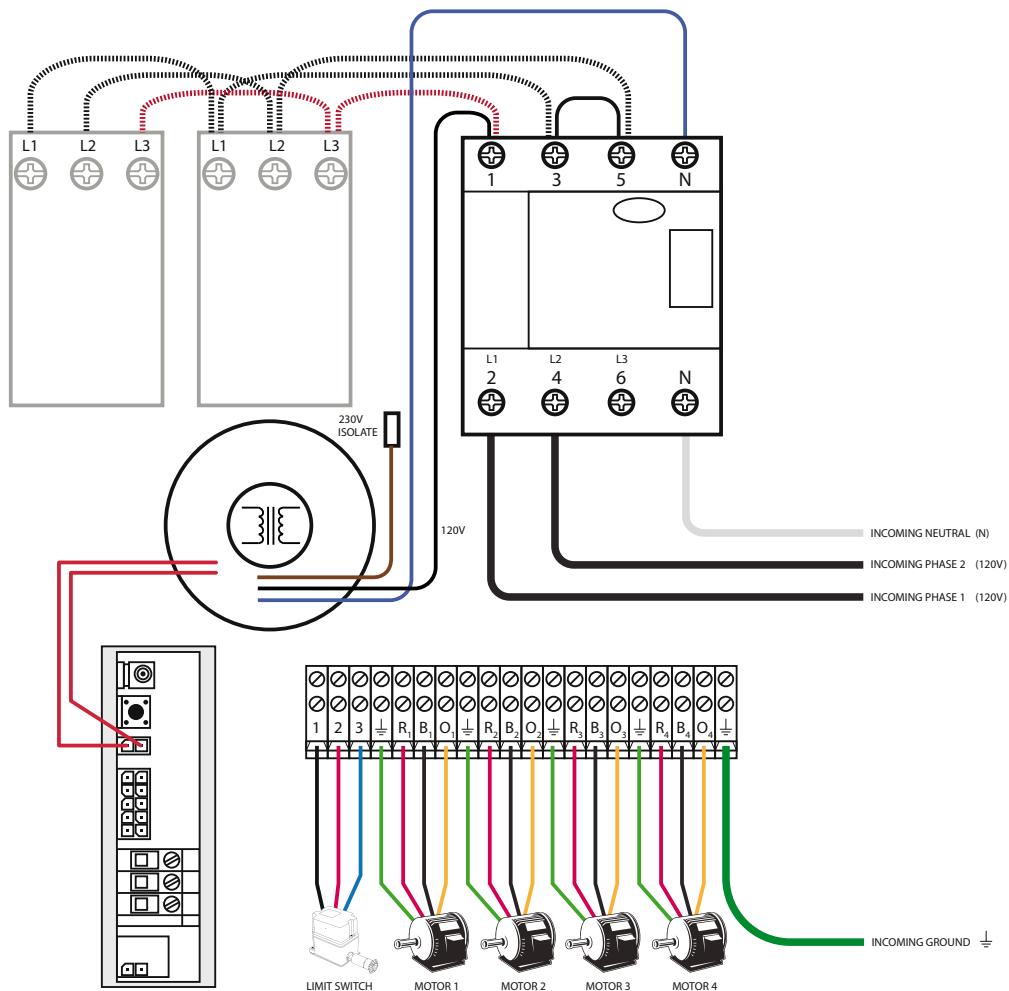

### FCC compliance statement

**MODIFICATION STATEMENT:**

Caution: The user is cautioned that changes or modifications not expressly approved by the party responsible for compliance could void the user's authority to operate the equipment.

**15.105 CLASS B DIGITAL DEVICE OR PERIPHERAL**

Note: This equipment has been tested and found to comply with the limits for a Class B digital device, pursuant to part 15 of the FCC Rules. These limits are designed to provide reasonable protection against harmful interference in a residential installation. This equipment generates, uses and can radiate radio frequency energy and, if not installed and used in accordance with the instructions, may cause harmful interference to radio communications. However, there is no guarantee that interference will not occur in a particular installation. If this equipment does cause harmful interference to radio or television reception, which can be determined by turning the equipment off and on, the user is encouraged to try to correct the interference by one or more of the following measures:

- Reorient or relocate the receiving antenna.
- Increase the separation between the equipment and receiver.
- Connect the equipment into an outlet on a circuit different from that to which the receiver is connected.
- Consult the dealer or an experienced radio/TV technician for help.



IM-TS-001-A10

14895 NE 20th Ave      Toll free phone 1-866-629-0780  
North Miami FL 33181      Toll free fax 1-866-254-5850  
usa@tele-radio.com

[www.tele-radio.com](http://www.tele-radio.com)