

TELE RADIO

INDUSTRIAL RADIO REMOTE CONTROLS

PANTHER

Installation instructions



PN-RX-MN5 (PN-R8-1), PN-RX-MD11 (PN-R8-6), PN-RX-MN5E (PN-R8-10),
PN-RX-MD11E (PN-R8-11), PN-TX-MD3M (PN-T13-3), PN-TX-MD6M (PN-T13-6),
PN-TX-MD8M (PN-T13-8), PN-TX-MD10M (PN-T13-10), PN-TX-MD3 (PN-T21-3),
PN-TX-MD6 (PN-T21-6), PN-TX-MD8 (PN-T21-8), PN-TX-MD10 (PN-T21-10),
PN-TX-MN3 (PN-T7-16), PN-TX-MN6 (PN-T7-15), PN-TX-MN8 (PN-T7-14)

Language: English (original)

CONTENTS

| | |
|---|----|
| Chapter 1: CUSTOMER INFORMATION | 3 |
| Chapter 2: PRODUCT PAGES | 5 |
| PN-RX-MN5, PN-RX-MN5E Base board receiver | 5 |
| PN-RX-MD I I, PN-RX-MD I I E Base board receiver with a Relay expansion board | 7 |
| PN-TX-MD, PN-TX-MDM, PN-TX-MN Transmitters | 12 |
| Chapter 3: INSTALLERS GUIDE | 15 |
| Default radio mode | 15 |
| Start the transmitter | 15 |
| Register the transmitter in the receiver | 15 |
| Erase all transmitters from the receiver | 16 |
| Turn the transmitter off | 16 |
| Frequencies & channels | 16 |
| Logout | 17 |
| Make a Load selection | 18 |
| Relay functionality | 18 |
| Operating mode I | 19 |
| Chapter 4: BATTERY GUIDE | 20 |
| Chapter 5: CERTIFICATIONS CHAPTER | 22 |

CHAPTER 1: CUSTOMER INFORMATION

THANK YOU FOR PURCHASING A TELE RADIO AB PRODUCT

READ ALL INSTRUCTIONS AND WARNINGS CAREFULLY BEFORE MOUNTING, INSTALLING AND CONFIGURATING THE PRODUCTS.

These instructions are published by Tele Radio AB without any guarantee. The instructions may be removed or revised by Tele Radio AB at any time and without further notice. Corrections and additions will be added to the latest version of the instruction.

IMPORTANT! These instructions are directed to installers. There are separate instructions directed towards end users. The instructions that contain information on the installation and configuration of the radio remote control unit on the machine are not intended to be passed on to the end user. Only such information may be passed on to the end user that is needed to operate the machine correctly by radio remote control.

Tele Radio AB products are covered by a guarantee/ warranty against material, construction or manufacturing faults. During the guarantee/ warranty period, Tele Radio AB may replace the product or faulty parts with new. Work under guarantee/ warranty must be carried out by Tele Radio AB or by an authorized service center specified by Tele Radio AB. Contact your Tele Radio AB representative if you need support or service.

©Tele Radio AB
Datavägen 21
SE-436 32 ASKIM
SWEDEN
Tel: +46-31-748 54 60
Fax: +46-31-68 54 64
www.tele-radio.com

WARNINGS & RESTRICTIONS

WARNING! Tele Radio remote controls are often built into wider applications. We recommend that the system is provided with a wired emergency stop where necessary.

INSTALLING, CONNECTING AND MOUNTING

- Allow only licensed or qualified personnel to install the product.
- Switch the power supply off to the receiver before connecting the equipment.
- Check that you have connected the power supply to the correct connection terminal.
- To utilize the safety of the system, use the stop relays in the safety circuitry of the object that you want to control.
- Use undamaged cables. No cables should hang loose.
- Avoid installing in areas affected by strong vibrations.
- Place the receiver well away from wind, damp and water.
- Cable glands and vent plugs must face down to prevent water from seeping in.

THE USER

- Make sure that the user is following the instructions.
- Make sure that the user has reached the certified age of your country to operate the equipment.
- Make sure that the user is not under the influence of drugs, alcohol and medicines.
- Allow only qualified personnel to have access to the transmitter and operate the equipment.
- Make sure that the user does not leave the transmitter unsupervised.
- Make sure that the user always turns the transmitter off when not in use.
- Make sure that the user keeps a good overview of the work area.

MAINTENANCE

- Use the stop button to start and turn off the transmitter as often as possible.
- When error messages are shown, it is very important to find out what caused them.
- If the stop button is mechanically damaged, contact your representative for service immediately.
- Always contact your representative for service and maintenance work on the product.
- Write down the serial numbers/ ID codes of the receivers and transmitters used. This information should be recorded on the “Settings document” for your product (download from our web-site).
- Avoid registering transmitters to receivers where it is not being used.
- Keep the safety instruction for future reference. Always download the configurations instruction from our web site for the latest version available.

CHAPTER 2: PRODUCT PAGES

PN-RX-MN5, PN-RX-MN5E BASE BOARD RECEIVER

WARNING! The receiver must NOT be opened by any other than a qualified installer. Make sure to turn the electricity off before opening the receiver.

Base board:

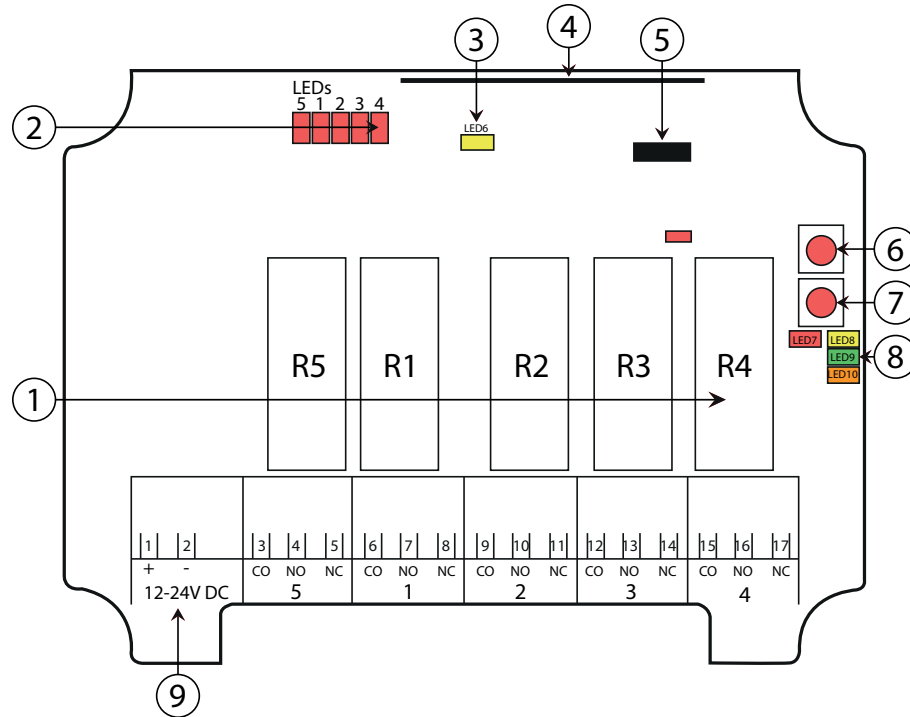

| | |
|----------------------------------|--|
| 1. Function relays I-5 | 6. Function button (cancel) |
| 2. Function relay LEDs I-5 (red) | 7. Select button (OK) |
| 3. Power LED (yellow) | 8. Function LEDs (7=red, 8=yellow, 9=green, 10=orange) |
| 4. Radio module | 9. Terminal block for input power |
| 5. Programming connector | |

TERMINAL BLOCK FOR INPUT POWER ON BASE BOARD

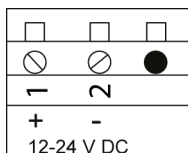

| |
|---------------------------------|
| 1. 12 - 24V DC |
| 2. Negative terminal DC voltage |

FUNCTION LEDS INDICATION IN OPERATING MODE

| Function LED | Off | On | Indicates |
|--|-----|----|--|
| 7 (red) | x | | No transmitter is registered. |
| | | x | Flashes once: One or more transmitters are registered. No radio transmission established. |
| | | x | Double flash: One or more transmitters are registered and logged in. No radio transmission established. |
| | | x | Radio transmission established. |
| 8 (yellow) | | x | Receiving a radio packet from a transmitter other than a Panther. |
| 8 (yellow) 9 (green) | | x | Receiving a radio packet from a transmitter set to the radio mode different from that of a receiver. |
| 8 (yellow) 10 (orange) | | x | Receiving a radio packet from a transmitter that is not registered. |
| 9 (green) | | x | Receiving a radio packet, low signal (RSSI). |
| 10 (orange) | | x | Receiving a radio packet, configuration ID not accepted. |
| 9 (green) 10 (orange) | | x | Receiving a radio packet, custom ID not accepted. |
| 8 (yellow) 9 (green) 10 (orange) | | x | 1. Receiving a radio packet from a registered transmitter. The receiver is already controlled by another registered transmitter. NOTE! "Radio link" must be activated in the receiver. 2. Load select mode is activated. Incorrect Load is selected on the transmitter. |

PN-RX-MD11, PN-RX-MD11E BASE BOARD RECEIVER WITH A RELAY EXPANSION BOARD

WARNING! The receiver must NOT be opened by any other than a qualified installer. Make sure to turn the electricity off before opening the receiver.

Base board:

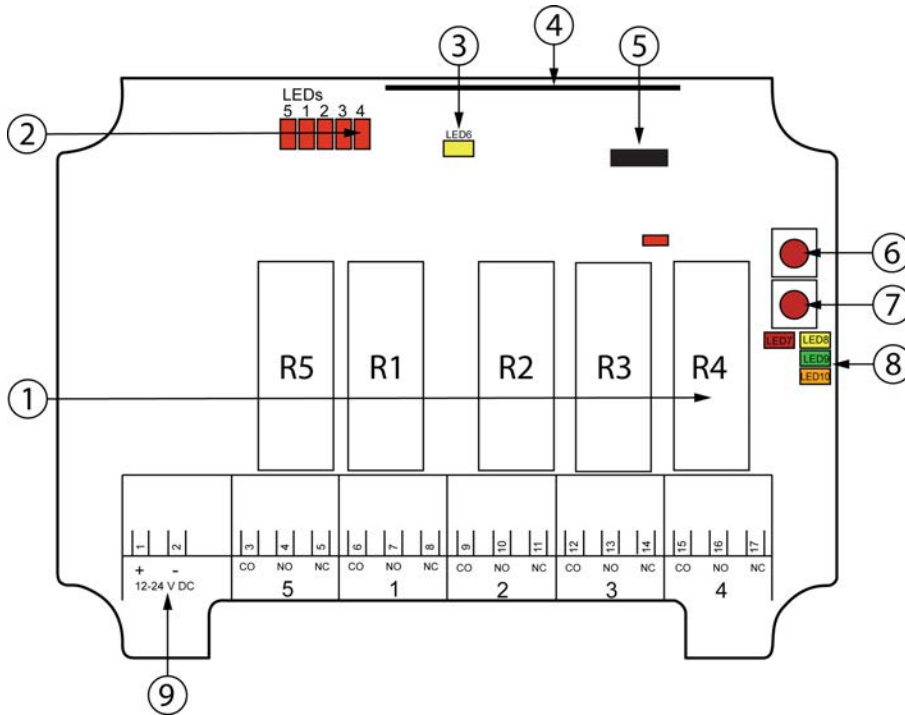

| | |
|--------------------------|--|
| 1. Function relays 1-5 | 6. Function button (cancel) |
| 2. Relay LEDs 1-5 (red) | 7. Select button (OK) |
| 3. Power LED (yellow) | 8. Function LEDs (7=red, 8=yellow, 9=green, 10=orange) |
| 4. Radio module | 9. Terminal block for input power |
| 5. Programming connector | |

Relay expansion board:

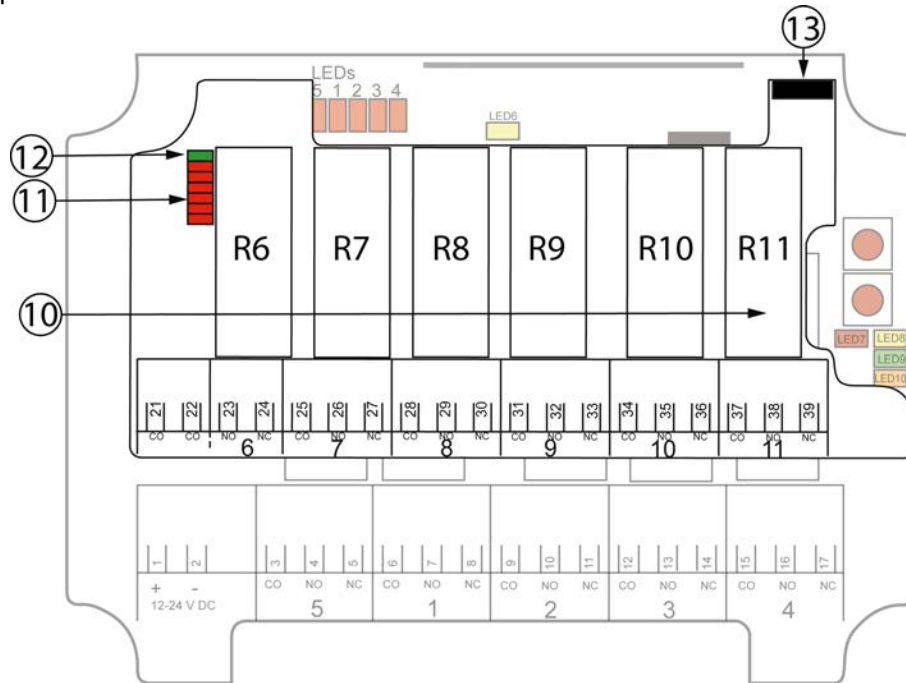

| | |
|---------------------------|-------------------------------|
| 10. Function relays 6-11 | 12. Communication LED (green) |
| 11. Relay LEDs 6-11 (red) | 13. Programming connector |

TERMINAL BLOCK FOR INPUT POWER ON BASE BOARD

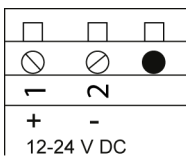

| |
|---------------------------------|
| 1. 12 - 24V DC |
| 2. Negative terminal DC voltage |

TERMINAL BLOCK FOR INPUT POWER ON HIGH VOLTAGE EXPANSION BOARD

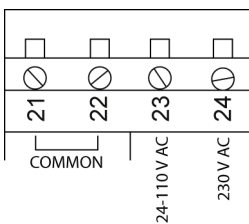

| | |
|------------|----------------|
| 21. Common | 23. 24-110V AC |
| 22. Common | 24. 230V AC |

FUNCTION LEDS INDICATION IN OPERATING MODE

| Function LED | Off | On | Indicates |
|--|-----|----|--|
| 7 (red) | x | | No transmitter is registered. |
| | | x | Flashes once: One or more transmitters are registered. No radio transmission established. |
| | | x | Double flash: One or more transmitters are registered and logged in. No radio transmission established. |
| | | x | Radio transmission established. |
| 8 (yellow) | | x | Receiving a radio packet from a transmitter other than a Panther. |
| 8 (yellow) 9 (green) | | x | Receiving a radio packet from a transmitter set to the radio mode different from that of a receiver. |
| 8 (yellow) 10 (orange) | | x | Receiving a radio packet from a transmitter that is not registered. |
| 9 (green) | | x | Receiving a radio packet, low signal (RSSI). |
| 10 (orange) | | x | Receiving a radio packet, configuration ID not accepted. |
| 9 (green) 10 (orange) | | x | Receiving a radio packet, custom ID not accepted. |
| 8 (yellow) 9 (green) 10 (orange) | | x | 1. Receiving a radio packet from a registered transmitter. The receiver is already controlled by another registered transmitter. NOTE! "Radio link" must be activated in the receiver. 2. Load select mode is activated. Incorrect Load is selected on the transmitter. |

TECHNICAL DATA

| | |
|--|--|
| Number of function relays | PN-RX-MN5, PN-RX-MN5E: 5 PN-RX-MD11, PN-RX-MD11E: 11 (potential free*, 10A, 250V AC) |
| Input power | 12-24V DC |
| Digital inputs | 8 |
| Duplex communication | No |
| Max. number of registered transmitters | 8 |
| IP class | 66 |
| Size | 120 x 117 x 51 mm / 4.7 x 4.6 x 2 in |
| Weight | 400 g / 0.8 lbs |
| Operating temperature | -20 - +55 °C / -4 - +130 °F |
| Operating frequency | 2405-2480 MHz |
| Number of channels | 16 (channel 11-26) |
| Channel separation | 5 MHz |
| Antenna | PN-RX-MN5, PN-RX-MD11: 1 internal PCB antenna PN-RX-MN5E, PN-RX-MD11E: 1 external antenna, reversed SMA |

*potential free means that you have to supply voltage to get voltage out of a relay

CURRENT CONSUMPTION

| Input power | Min.* | Max.** |
|-------------|--------|--------|
| 12V DC | 0.02A | 0.3A |
| 24V DC | 0.02A | 0.2A |
| 24V AC | 0.02A | 0.2A |
| 48V AC | 0.01A | 0.05A |
| 110V AC | 0.005A | 0.03A |
| 230V AC | 0.01A | 0.02A |

*Minimum current consumption= Receiver powered, no radio session established, nothing else activated on the receiver.

**Maximum current consumption= All relays activated on the receiver.

ANTENNA - MOUNTING DESCRIPTION

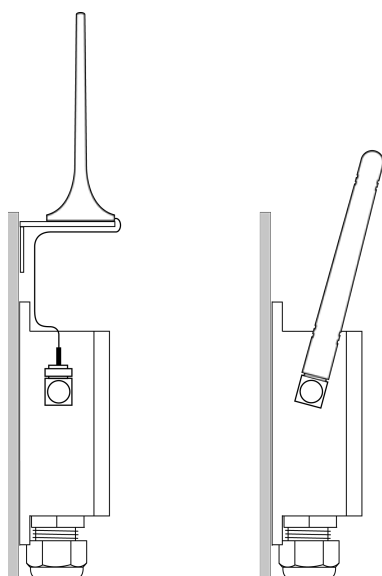

NOTE! For optimum performance: Place well away from metal objects, such as metal girders, high-voltage cables and other antennas.

- Antenna with cable - cable makes it possible for the antenna to be positioned freely and high above the ground.
- Antenna without cable - if the receiver is installed on a wall, the antenna should be angled out from the wall.

RECEIVER MEASUREMENTS

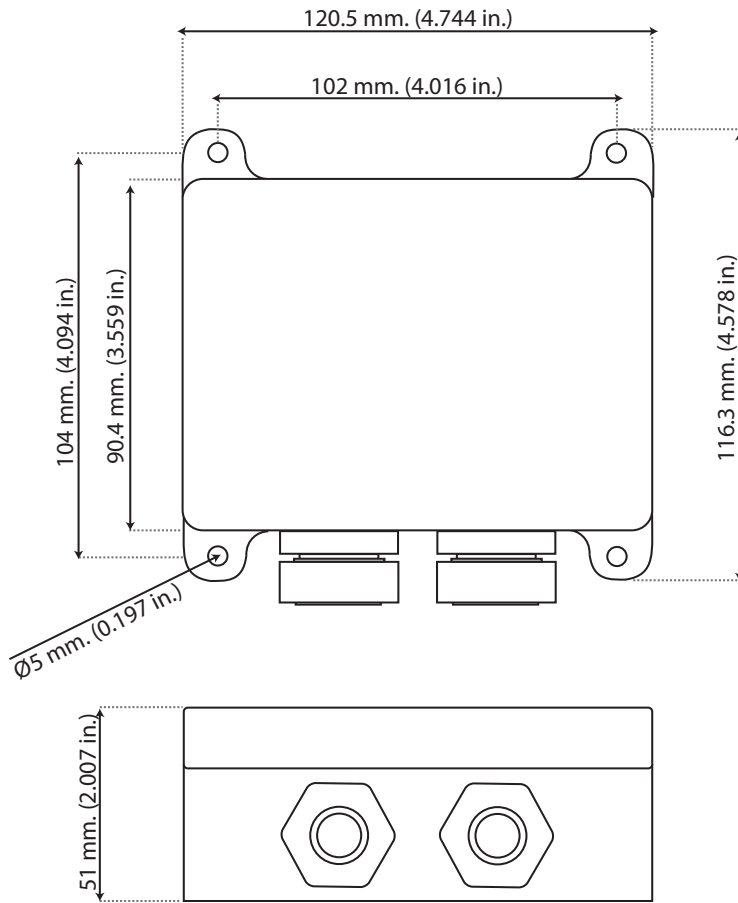

PN-TX-MD, PN-TX-MDM, PN-TX-MN TRANSMITTERS

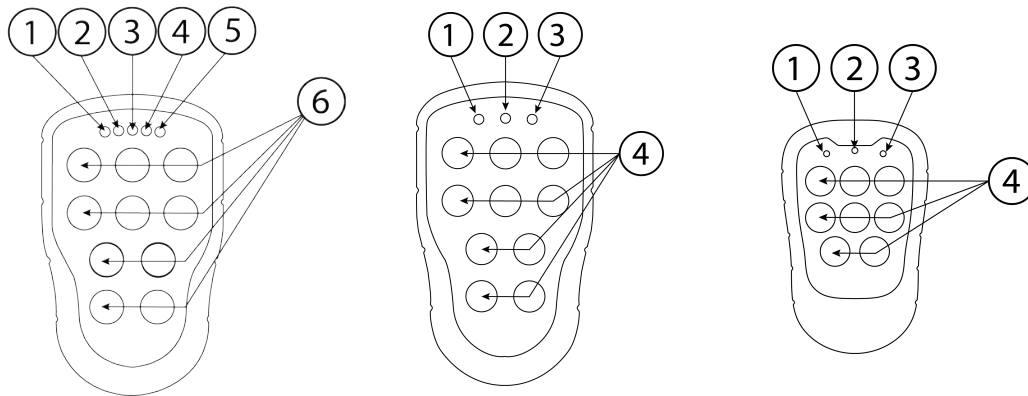

| PN-TX-MD | PN-TX-MDM | PN-TX-MN |
|-------------------------|-------------------------|-------------------------|
| 1. LED 1 (red) | 1. LED 1 (red) | 1. LED 1 (red) |
| 2. LED 2 (red) | 2. Top LED (red, green) | 2. Top LED (red, green) |
| 3. Top LED (red, green) | 3. LED 2 (red) | 3. LED 2 (red) |
| 4. LED 3 (red) | 4. Buttons (1-10) | 4. Buttons (1-8) |
| 5. LED 4 (red) | | |
| 6. Buttons (1-10) | | |

TRANSMITTER BACKSIDE

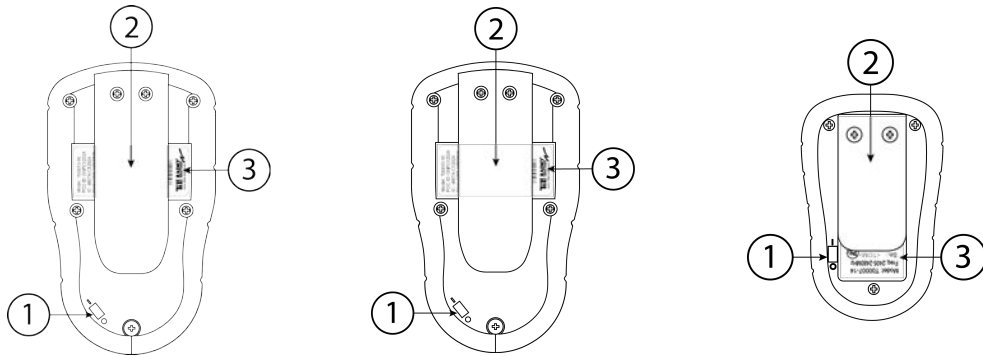

| PN-TX-MD | PN-TX-MDM | PN-TX-MN |
|--------------------|--------------------|--------------------|
| 1. On/Off switch | 1. On/off switch | 1. On/off switch |
| 2. Clip | 2. Clip | 2. Clip |
| 3. CE/FCC/IC label | 3. CE/FCC/IC label | 3. CE/FCC/IC label |

ON/OFF SWITCH

The transmitter has an on/off switch on the backside. The switch breaks the power supply from the battery. When in position 0/off, the transmitter cannot be started unless you connect the charger plug. When the transmitter is transported by airplane, the on/off switch must be in 0/off position. The switch should not be used as an on/off button for the transmitter.

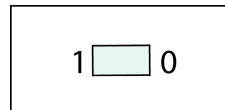

TECHNICAL DATA

| NO. OF BUTTONS | |
|----------------------------------|--------------------|
| PN-TX-MD3, PN-TX-MD3M, PN-TX-MN3 | 3 x 1-step button |
| PN-TX-MD6, PN-TX-MD6M, PN-TX-MN6 | 6 x 1-step button |
| PN-TX-MD8, PN-TX-MD8M, PN-TX-MN8 | 8 x 1-step button |
| PN-TX-MD10, PN-TX-MD10M | 10 x 1-step button |

| BATTERY | |
|---------------------|--------------|
| PN-TX-MD | 3 x 1.5V AAA |
| PN-TX-MDM, PN-TX-MN | 2 x 1.5V AAA |

| ON/OFF SWITCH | |
|-------------------------------|-----|
| PN-TX-MD, PN-TX-MDM, PN-TX-MN | Yes |

| DUPLEX COMMUNICATION | |
|-------------------------------|----|
| PN-TX-MD, PN-TX-MDM, PN-TX-MN | No |

| ANTENNA | |
|-------------------------------|------------------------|
| PN-TX-MD, PN-TX-MDM, PN-TX-MN | 1 internal PCB antenna |

| SIZE | |
|-----------|---|
| PN-TX-MD | 66 x 114 x 37.5 mm / 2.6 x 4.5 x 1.5 in |
| PN-TX-MDM | 66 x 114 x 37.5 mm / 2.6 x 4.5 x 1.5 in |
| PN-TX-MN | 52 x 83 x 17 mm / 2 x 3.3 x 0.7 in |

| WEIGHT | |
|-----------|------------------|
| PN-TX-MD | 135 g (0.29 lbs) |
| PN-TX-MDM | 135 g (0.29 lbs) |
| PN-TX-MN | 70 g (0.15 lbs) |

| OPERATING FREQUENCY | |
|-------------------------------|---------|
| PN-TX-MD, PN-TX-MDM, PN-TX-MN | 2.4 GHz |

| NO. OF CHANNELS | |
|-------------------------------|--------------------|
| PN-TX-MD, PN-TX-MDM, PN-TX-MN | 16 (channel 11-26) |

| CHANNEL SEPARATION | |
|-------------------------------|-------|
| PN-TX-MD, PN-TX-MDM, PN-TX-MN | 5 MHz |

| IP CLASS | |
|---------------------|----|
| PN-TX-MD, PN-TX-MDM | 67 |
| PN-TX-MN | 65 |

| OPERATING TEMPERATURE | |
|-------------------------------|-----------------------------|
| PN-TX-MD, PN-TX-MDM, PN-TX-MN | -20 - +55 °C / -4 - +130 °F |

CHAPTER 3: INSTALLERS GUIDE

DEFAULT RADIO MODE

The transmitter is set to discontinuous radio mode by default. To establish a radio link between the transmitter and the receiver, both need to be in the same radio mode.

The transmitter will start transmitting as soon as the batteries are inserted and any transmitter button is pressed. Radio transmission will end when all transmitter buttons are released.

Note that some settings can only be made when the products are transmitting continuously. Those sections are marked with the text: "Only for continuous radio mode".

To switch to continuous radio mode, the PC-program Settings Manager must be used. Please contact your representative for assistance.

START THE TRANSMITTER

1. Start the transmitter by pressing any button on the transmitter.

REGISTER THE TRANSMITTER IN THE RECEIVER

WARNING! Keep only transmitters, that you intend to use, registered in the receivers.

1. Press the Function button on the receiver.
Function LED lights red.
2. Press the Select button on the receiver.
All relay LEDs light red.
3. Press button 1 and 2 on the transmitter. Keep pressed.
All relay LEDs light red.
4. Relay LEDs flash 2 times.
5. Release transmitter buttons 1 and 2.
The relay LEDs flash 1 time.
The transmitter is registered.

ERASE ALL TRANSMITTERS FROM THE RECEIVER

1. Press the Function button on the receiver.
Function LED lights red.
2. Press the Select button on the receiver.
All relay LEDs light red.
3. All relay LEDs go out.
4. Release the Select button.
All transmitters are erased from the receiver.
If the red function LED flashes, one or more transmitters are still registered in the receiver.

TURN THE TRANSMITTER OFF

1. The transmitter turns off when no transmitter button is pressed.

FREQUENCIES & CHANNELS

| Channel | Frequency |
|---------|-----------|
| 11 | 2405 |
| 12 | 2410 |
| 13 | 2415 |
| 14 | 2420 |
| 15 | 2425 |
| 16 | 2430 |
| 17 | 2435 |
| 18 | 2440 |
| 19 | 2445 |
| 20 | 2450 |
| 21 | 2455 |
| 22 | 2460 |
| 23 | 2465 |
| 24 | 2470 |
| 25 | 2475 |
| 26 | 2480 |

Switch channel

NOTE! Only for the PN-TX-MD and when in continuous radio mode.

1. Start the transmitter. The top LED flashes green.
2. Press the Off-button on the transmitter. Keep pressed. The top LED flashes red.
3. Within 2 seconds, press and hold button 1 or button 3 to switch channel.
Button 1 = +I
Button 3 = -I
Top LED lights green. The channel is changed. The channel number is indicated by LED 1 and LED 4.
Ex. channel 26: LED 1 flashes 2 times, LED 4 flashes 6 times.
4. The transmitter switches off.

LOGOUT

NOTE! Only for the PN-TX-MD and when in continuous radio mode.

NOTE! Logout function is deactivated by default. Contact your representative for assistance.

Logout from the receiver

1. Press the receiver Select button. LED 10 (orange) lights.
2. Keep pressed (at least 4 seconds). LED 10 (orange) goes off.
3. The transmitter is now logged off. Any other registered transmitter can be logged in.

Quick logout

There are two alternatives for logging out from the transmitter.

Alternative 1:

1. Press the Logout-button on the transmitter. Keep pressed.
2. Press the Off-button. The top LED lights red.
3. The transmitter switches off after logging out.

Alternative 2:

1. Press the Off-button. Keep pressed.
2. Within 2 seconds, press the Logout-button. The top LED lights red.
3. The transmitter switches off after logging out.

AUTOMATIC SHUTDOWN

NOTE! You can not change the automatic shutdown time from the transmitter. Contact your representative for assistance.

The transmitter automatic shutdown time is set to 3 minutes by default.

MAKE A LOAD SELECTION

Load select mode for the transmitter PN-TX-MDM, PN-TX-MN and PN-TX-MD is deactivated by default (Load select mode 0).

NOTE! The loads are selected in the PC program Settings Manager. Contact your representative for assistance.

RELAY FUNCTIONALITY

NOTE! If Operating mode 0 is selected, you can not make these settings. Contact your representative for assistance.

NOTE! Momentary relay functionality is default. That means that the relay will only be activated when you press a button on the transmitter. When the button is released, the relay deactivates. Setting a relay to latching means that the relay gets activated every time that you press a button, but in this case the relay remains active until the button is pressed again.

NOTE! The settings options depend on the selected Operating mode.

Momentary or latching relay functionality

1. Press the receiver Function button 2 times. LED 8 (yellow) lights. The relay LEDs light.
2. Press the receiver Select button to switch relay functionality. The relay LEDs flash to indicate that a latching or momentary functionality can be set to the corresponding relays.
3. Press the receiver Function button to set latching or momentary functionality:
LED 8 (yellow) off = momentary relay functionality
LED 8 (yellow) on = latching relay functionality
4. Press the receiver Select button to step to the next available relay. When you have stepped through all the available relays, the receiver exits the settings menu.

OPERATING MODE 1

PN-TX-MD

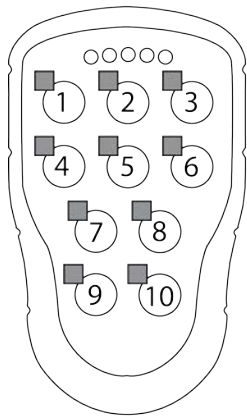

PN-TX-MDM

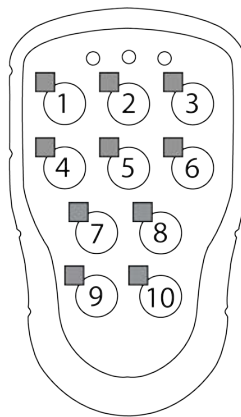

PN-TX-MN

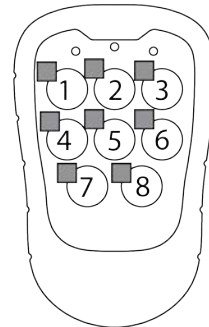

 Button functions

| | |
|---------------------------------|--|
| On relay | - |
| Working relay | Relay 11 is active when relay 1-10 is active |
| Recommended Load Selection mode | 0 |
| Programmable settings | Relay 1-10 can be set latching |
| Interlocking | - |
| Radio mode | Discontinuous |
| Zero position check | - |

CHAPTER 4: BATTERY GUIDE

BATTERY INFORMATION

WARNING! Do not recharge the batteries. Attempts to recharge may cause rupture or the leaking of hazardous liquids, which will corrode the equipment.

NOTE! Electronics and batteries must be physically separated before disposal. Make sure that electronics or batteries are not thrown in the household waste.

Switch batteries

PN-TX-MD

Battery type: 3 x 1.5V AAA / LR03 Alkaline

1. Take off the transmitter backside by unscrewing the 5 screws.
2. Switch the 3 x 1.5V AAA batteries.
Use alkaline for optimal performance.
3. Put the transmitter backside on again using the screwdriver.

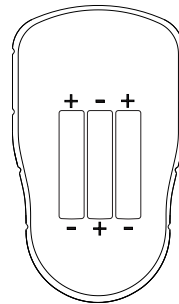

PN-TX-MDM

Battery type: 2 x 1.5V AAA / LR03 Alkaline

1. Take off the transmitter backside by unscrewing the 5 screws.
2. Switch the 2 x 1.5V AAA batteries.
Use alkaline for optimal performance.
3. Put the transmitter backside on again using the screwdriver.

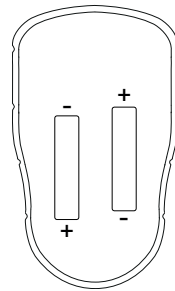

PN-TX-MN

Battery type: 2 x 1.5V AAA / LR03 Alkaline

1. Take off the transmitter backside by unscrewing the 3 screws.
2. Switch the 2 x 1.5V AAA batteries.
Use alkaline for optimal performance.
3. Put the transmitter backside on again using the screwdriver.

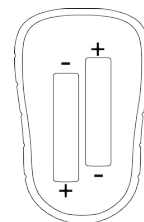

BATTERY PRECAUTIONS

Observe the following general battery warnings:

- As batteries contains flammable substances such as lithium or other organic solvents, they may cause heating, rupture or ignition.
- Risk of explosion if battery is replaced with a battery of an incorrect type.
- Do not short circuit, disassemble, deform or heat batteries.
- Never try to charge a visibly damaged or frozen battery.
- Keep batteries out of reach of small children. Should a child swallow a battery, consult a physician immediately.
- Avoid direct soldering to batteries.
- When discarding batteries, insulate the + and - terminals of batteries with insulating/ masking tape. Do not put multiple batteries in the same plastic bag.
- When improperly disposed, batteries may short circuit, causing them to become hot, burst or ignite.
- Store in a cool location. Keep batteries away from direct sunlight, high temperature, and high humidity.
- Do not throw batteries into fire.

ROHS AND WEEE

In accordance with Directive 2011/65/EU on restriction of the use of certain hazardous substances in electrical and electronic equipment (RoHS) and Directive 2012/19/EU on waste electrical and electronic equipment (WEEE), Tele Radio AB strives to minimize the use of hazardous materials, promotes reuse and recycling, and reduces emissions to air, soil and water. When a commercially viable alternative is available, Tele Radio AB strives to restrict or eliminate substances and materials that pose an environmental, health or safety risk.

GUARANTEE, SERVICE, REPAIRS AND MAINTENANCE

The Tele Radio AB products are covered by a guarantee/warranty against material, construction and manufacturing faults. During the guarantee/warranty period, Tele Radio AB may replace the product or faulty parts. Work under guarantee/warranty must be carried out by Tele Radio AB or by an authorized service centre specified by Tele Radio AB.

This is not covered by the guarantee/ warranty:

- Faults resulting from normal wear and tear
- Parts of a consumable nature
- Products that have been subject to unauthorized modifications
- Faults resulting from incorrect installation and use
- Damp and water damage

Maintenance:

- Repairs and maintenance must be carried out by qualified personnel
- Use spare parts from Tele Radio AB only
- Contact your representative if you require service or other assistance
- Keep the product in a dry, clean place
- Keep contacts and antennas clean
- Wipe off dust using a slightly damp, clean cloth

WARNING! Never use cleaning solutions or high-pressure water.

CHAPTER 5: CERTIFICATIONS CHAPTER

FCC STATEMENT

Statement for warning:

Caution: The user is cautioned that changes or modifications not expressly approved by the party responsible for compliance could void the user's authority to operate the equipment.

This device complies with Industry Canada licence-exempt RSS standard(s) and Part 15 of the FCC Rules. Operation is subject to the following two conditions:

- (1) this device may not cause harmful interference, and
- (2) this device must accept any interference received, including interference that may cause undesired operation.

Le présent appareil est conforme aux CNR d'Industrie Canada applicables aux appareils radio exempts de licence et la partie 15 des Règles FCC. L'exploitation est autorisée aux deux conditions suivantes :

- (1) l'appareil ne doit pas produire de brouillage, et
- (2) l'utilisateur de l'appareil doit accepter tout brouillage radioélectrique subi, même si le brouillage est susceptible d'en compromettre le fonctionnement.

This equipment complies with FCC and IC radiation exposure limits set forth for an uncontrolled environment. End user must follow the specific operating instructions for satisfying RF exposure compliance. This transmitter must not be co-located or operating in conjunction with any other antenna or transmitter.

Cet appareil est conforme aux limites d'exposition au rayonnement RF stipulées par la FCC et l'IC pour une utilisation dans un environnement non contrôlé. L'utilisateur final doit suivre les instructions de fonctionnement spécifiques pour le respect d'exposition aux RF. Les émetteurs ne doivent pas être placés près d'autres antennes ou émetteurs ou fonctionner avec ceux-ci.

Note: this equipment has been tested and found to comply with the limits for a class b digital device, pursuant to part 15 of the FCC rules. These limits are designed to provide reasonable protection against harmful interference in a residential installation. This equipment generates, uses and can radiate radio frequency energy and, if not installed and used in accordance with the instructions, may cause harmful interference to radio communications. However, there is no guarantee that interference will not occur in a particular installation. If this equipment does cause harmful interference to radio or television reception, which can be determined by turning the equipment off and on, the user is encouraged to try to correct the interference by one or more of the following measures:

- reorient or relocate the receiving antenna.
- increase the separation between the equipment and receiver.
- connect the equipment into an outlet on a circuit different from that to which the receiver is connected.
- consult the dealer or an experienced radio/TV technician for help.

Under Industry Canada regulations, this radio transmitter may only operate using an antenna of a type and maximum (or lesser) gain approved for the transmitter by Industry Canada. To reduce potential radio interference to other users, the antenna type and its gain should be so chosen that the equivalent isotropically radiated power (e.i.r.p.) is not more than that necessary for successful communication. Conformément à la réglementation d'Industrie Canada, le présent émetteur radio peut fonctionner avec une antenne d'un type et d'un gain maximal (ou inférieur) approuvé pour l'émetteur par Industrie Canada. Dans le but de réduire les risques de brouillage radioélectrique à l'intention des autres utilisateurs, il faut choisir le type d'antenne et son gain de sorte que la puissance isotrope rayonnée équivalente (p.i.r.e.) ne dépasse pas l'intensité nécessaire à l'établissement d'une communication satisfaisante.

FCC/IC LABEL ON THE TRANSMITTER

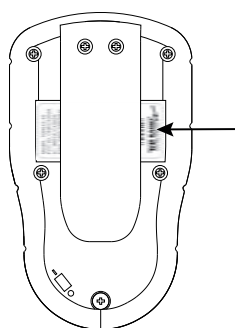

PN-TX-MD

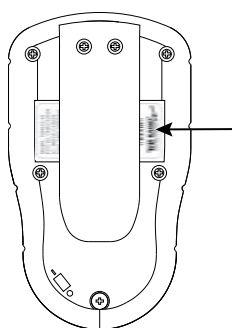

PN-TX-MDM

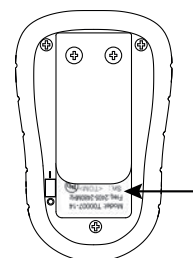

PN-TX-MN

EC/EEA DECLARATION OF CONFORMITY

EC/EEA DECLARATION OF CONFORMITY



The undersigned, representing the following manufacturer:

NAME: Tele Radio AB
ADDRESS: Datavägen 21, SE-436 32 Askim, SWEDEN
TELEPHONE NO: 46-31-7485460 TELEFAX NO: 46-31-685464

Herewith declares that the product(s):

TRANSMITTERS PN-T7-14, PN-T7-15, PN-T7-16, PN-T13-3, PN-T13-6, PN-T13-8, PN-T13-10

Is in conformity with the provisions of the following harmonized standards, other standards and directives:

| | | |
|-----------------|---|-----------------|
| 1999/5/EC | Directive 1999/5/EC of the European Parliament and of the Council on radio equipment and telecommunications terminal equipment and the mutual recognition of their conformity (R&TTE) | |
| 2006/95/EC | Directive 2006/95/EC of the European Parliament and of the Council on harmonisation of the laws of the Member states relating to electrical equipment designed for use within certain voltage limits | |
| 2004/108/EC | Directive 2004/108/EC of the European Parliament and of the Council on the approximation of the laws of the Member states relating to electromagnetic compatibility | |
| 2011/65/EC | Directive 2011/65/EC of the European Parliament and of the Council on the restriction of the use of certain hazardous substances in electrical and electronic equipment | |
| EN 62479 | Assessment of the compliance of low power electronic and electrical equipment with the basic restrictions related to human exposure to electromagnetic fields (10 MHz to 300 GHz) | HEALTH & SAFETY |
| EN 60950-1 | Information technology equipment-SAFETY-Part 1: General requirements | HEALTH & SAFETY |
| EN 301489-1/-3 | Electromagnetic compatibility and Radio spectrum Matters (ERM): ElectroMagnetic Compatibility (EMC) standard for radio equipment and services: Part 1: Common technical requirements- Part 3: Specific conditions for Short-Range Devices (SRD) operating on frequencies between 9 KHz and 40 GHz | EMC |
| EN 300 440-1/-2 | Electromagnetic compatibility and Radio spectrum Matters (ERM) - Short range devices - Radio equipment to be used in the 1 GHz to 40 GHz frequency range - Part 1: Technical characteristics and test methods - Part 2: Harmonized EN under article 3.2 of the R&TTE | RADIO |
| EN 50581 | Technical documentation for the assessment of electrical and electronic products with respect to the restriction of hazardous substances | |

Authorized to compile technical file:

NAME: Jesper Ribbe
ADDRESS: Same as manufacturer

Askim April 29th, 2013

Jesper Ribbe
Research & Development Manager, Tele Radio AB

CER-PN-EC002-A02

EC/EEA DECLARATION OF CONFORMITY



The undersigned, representing the following manufacturer:

NAME: Tele Radio AB
ADDRESS: Datavägen 21, SE-436 32 Askim, SWEDEN
TELEPHONE NO: 46-31-7485460 TELEFAX NO: 46-31-685464

Herewith declares that the product(s):

RECEIVERS PN-R8-1, PN-R8-2, PN-R8-6, PN-R8-10, PN-R8-11

Is in conformity with the provisions of the following harmonized standards, other standards and directives:

| | | |
|-----------------|---|-------------------|
| 1999/5/EC | Directive 1999/5/EC of the European Parliament and of the Council on radio equipment and telecommunications terminal equipment and the mutual recognition of their conformity (R&TTE) | |
| 2006/95/EC | Directive 2006/95/EC of the European Parliament and of the Council on harmonisation of the laws of the Member states relating to electrical equipment designed for use within certain voltage limits | |
| 2004/108/EC | Directive 2004/108/EC of the European Parliament and of the Council on the approximation of the laws of the Member states relating to electromagnetic compatibility | |
| 2011/65/EC | Directive 2011/65/EC of the European Parliament and of the Council on the restriction of the use of certain hazardous substances in electrical and electronic equipment | |
| EN 60950-1 | Information technology equipment-SAFETY-Part 1: General requirements | HEALTH/ SAFETY |
| EN 301489-1/-17 | Electromagnetic compatibility and Radio spectrum Matters (ERM): ElectroMagnetic Compatibility (EMC) standard for radio equipment and services: Part 1: Common technical requirements- Part 17: Specific conditions for Wideband data and HIPERLAN equipment | EMC |
| EN 300 328-1/-2 | Electromagnetic compatibility and Radio spectrum Matters (ERM) - Wideband Transmission systems - Data transmission equipment operating in the 2,4 GHz ISM band and using spread spectrum modulation techniques: Part 1: Technical characteristics and test conditions. Part 2: Harmonized EN covering essential requirements under article 3.2 of the R&TTE Directive | RADIO |
| EN 50581 | Technical documentation for the assessment of electrical and electronic products with respect to the restriction of hazardous substances | |

Authorized to compile technical file:

NAME: Jesper Ribbe
ADDRESS: Same as manufacturer

Askim November 28th, 2014

Jesper Ribbe
Research & Development Manager, Tele Radio AB

CER-PN-EC005-A03

EC/EEA DECLARATION OF CONFORMITY



The undersigned, representing the following manufacturer:

NAME: **Tele Radio AB**
ADDRESS: **Datavägen 21, SE-436 32 Askim, SWEDEN**
TELEPHONE NO: **46-31-7485460** TELEFAX NO: **46-31-685464**

Herewith declares that the product(s):

TRANSMITTERS PN-T21-3, PN-T21-6, PN-T21-8, PN-T21-10

Is in conformity with the provisions of the following harmonized standards, other standards and directives:

| | | |
|-----------------|--|------------|
| 1999/5/EC | Directive 1999/5/EC of the European Parliament and of the Council on radio equipment and telecommunications terminal equipment and the mutual recognition of their conformity (R&TTE) | |
| 2006/95/EC | Directive 2006/95/EC of the European Parliament and of the Council on harmonisation of the laws of the Member states relating to electrical equipment designed for use within certain voltage limits | |
| 2004/108/EC | Directive 2004/108/EC of the European Parliament and of the Council on the approximation of the laws of the Member states relating to electromagnetic compatibility | |
| 2011/65/EC | Directive 2011/65/EC of the European Parliament and of the Council on the restriction of the use of certain hazardous substances in electrical and electronic equipment | |
| EN 62479 | Assessment of the compliance of low-power electronic and electrical equipment with the basic restrictions related to human exposure to electromagnetic fields (10 MHz to 300 GHz) | HEALTH |
| EN 60950-1 | Information technology equipment-SAFETY-Part 1: General requirements | SAFETY/LVD |
| EN 301489-1/-17 | Electromagnetic compatibility and Radio spectrum Matters (ERM): ElectroMagnetic Compatibility (EMC) standard for radio equipment and services: Part 1: Common technical requirements- Part 17: Specific conditions for Wideband data and HIPERLAN equipment | EMC |
| EN 300328-1/-2 | Electromagnetic compatibility and Radio spectrum Matters (ERM) - Wideband Transmission systems - Data transmission equipment operating in the 2,4 GHz ISM band and using spread spectrum modulation techniques - Part 1: Technical characteristics and test conditions. Part 2: Harmonized EN covering essential requirements under article 3.2 of the R&TTE Directive | RADIO |
| EN 50581 | Technical documentation for the assessment of electrical and electronic products with respect to the restriction of hazardous substances | |

Authorized to compile technical file:

NAME: **Jesper Ribbe**
ADDRESS: Same as manufacturer

Askim January 13th 2015

Jesper Ribbe
Research & Development Manager, Tele Radio AB

CER-PN-EC009-A01

(THIS PAGE IS INTENTIONALLY LEFT BLANK)



www.teleradio.com

TELE RADIO SVERIGE
Sweden

TELE RADIO GmbH
Germany

TELE RADIO ASIA
China

TELE RADIO TURKEY
Turkey

TELE RADIO ITALIA
Italy

TELE RADIO LTD
England

TELE RADIO LLC
North & South America

TELE RADIO BV
Benelux

TELE RADIO AS
Norway

TELE RADIO SL
Spain