

Wireless LAN Stand

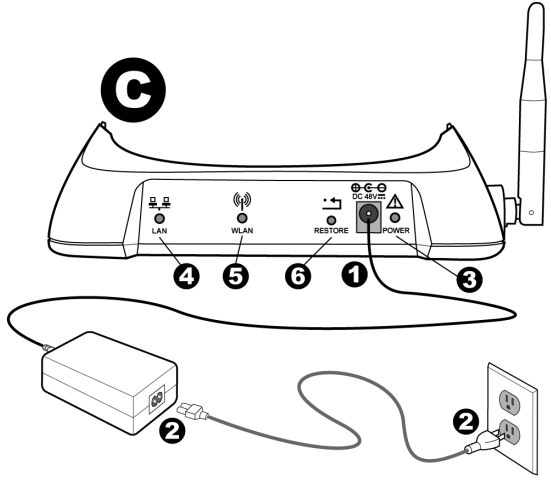
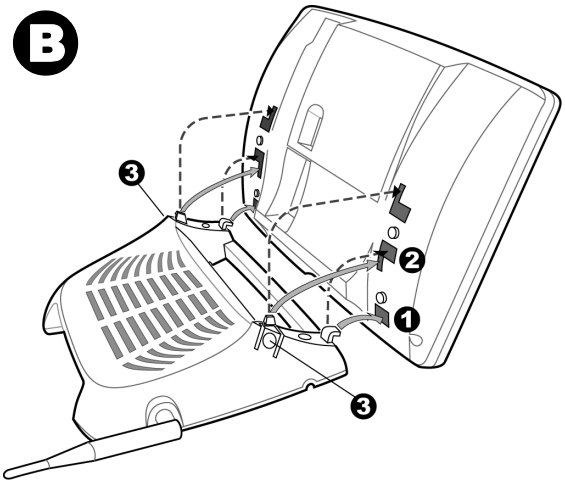
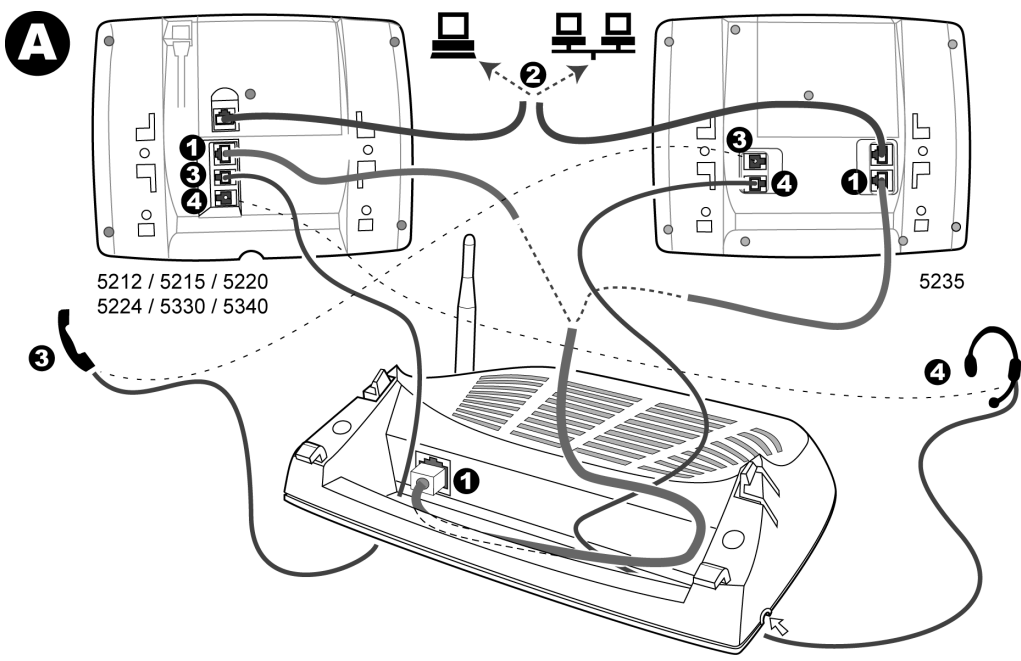

About the Mitel Wireless LAN Stand

The Mitel Wireless LAN Stand is a network accessory that connects to the 5200/5300 Family of IP Phones. The Wireless LAN Stand provides an 802.11 b/g WiFi LAN connection in place of a wired Ethernet LAN. The Wireless LAN Stand snaps to the bottom of the phone and is connected to the phone by 10/100BaseT wired Ethernet. The Wireless LAN Stand can operate as a wireless client or as an access point.

What You Need to Install the Wireless LAN Stand

The following items come in the box:

- Mitel Wireless LAN Stand
- Power supply for the Wireless LAN Stand
- Short, Cat5 Ethernet cable

Before configuring the Wireless LAN Stand, you also need:

- A 5200/5300 Family IP Phone (which includes an Ethernet LAN cable)
- A region-specific power cord with an IEC 320 C7 connector
- A PC with a 10/100BaseT Ethernet LAN port (used for configuration)
- Web browser on the PC for configuration, such as Microsoft Internet Explorer 5.0 or above, or Netscape Navigator 4.78 or above
- *Wireless LAN Stand Configuration and Engineering Guidelines* (can be found at <http://edocs.Mitel.com>)

Before doing anything to the Wireless LAN Stand, it is strongly recommended that you read and understand the above guidelines document.

Connecting the Wireless LAN Stand (See Figure A)

Configure the Wireless LAN Stand before installing it. Normally, you configure the stand using a PC directly connected to the Ethernet port on the stand. See the *Wireless LAN Stand Configuration and Engineering Guidelines* document for detailed instructions on configuring the stand.

After installation, the Wireless LAN Stand's configuration or status can be checked or changed by connecting a PC with an Ethernet connection and a browser into the PC port of the Mitel IP Phone. See "Accessing the Configuration and Status of the Wireless LAN Stand" in this guide.

To connect the Wireless LAN Stand to the IP Phone:

- 1 Connect one end of the short, Cat5 Ethernet cable into the jack on the front of the Wireless LAN Stand. Route the cable toward the right of the unit as shown. Connect the other end of the cable to the LAN port on the bottom of the IP Phone.
- 2 If the Wireless LAN Stand is configured as a client or you want to check the Wireless LAN Stand's status, connect your PC to the PC port on the IP Phone. If the Wireless LAN Stand is configured as an access point, connect the Ethernet LAN cable into the PC port of the IP Phone.

NOTE: A PC is required for configuring the Wireless LAN Stand; however it is not needed for normal operation of the phone or the Wireless LAN Stand.

- 3 Connect the IP Phone's handset to the cable provided, and route the cable from the left side under the unit and out the opening as shown. Plug the other end of the cable into the handset jack on the IP Phone.
- 4 If a headset is required, route its cable from underneath the right of the Stand and out through the opening as shown. Plug the cable into the headset jack of the IP Phone.

NOTE: Insert the cables into the notches in the bottom of the Stand, so the Stand will sit level on the desk surface.

Attaching the Wireless LAN Stand (See Figure B)

You can attach the IP Phone to the Wireless LAN Stand in two positions, depending on your preference: upright and low angle.

To attach the Stand:

- 1 For the upright position, fit the hooks on the front of the Stand into the notches nearest to the front edge of the IP Phone. Rotate the Stand to the bottom of the phone so the hooks snap into the notches.
- NOTE:** Make sure the short cable is not pinched between the phone and the stand when you snap them together.
- 2 For the low angle position, fit the hooks on the front of the Stand into the middle set of notches on the bottom of the IP Phone. Rotate the Stand to the bottom of the phone so the hooks snap into the notches.
 - 3 To detach the stand from the IP Phone, press the release buttons on both sides of the stand and pull it away from the phone.

Connecting the Power Supply (See Figure C)

To connect the power:

- 1 Connect the power supply DC cable to the rear jack on the Wireless LAN Stand. The power supply will provide power to both the Wireless LAN Stand and the IP Phone.
- 2 Connect the power supply to a main cord and wall plug, using a region-specific power cord with an IEC 320 C7 connector.
- 3 The Power LED lights up when the power is properly connected.
- 4 The LAN LED lights up when a link has been established and blinks to indicate wired LAN activity.
- 5 The WLAN LED blinks at various rates to indicate wireless connectivity states.
- 6 The Restore button clears all of the Wireless LAN Stand configuration settings to the factory default values. Activate the Restore button by inserting a pen in the hole and holding in for at least 10 seconds. You must reconfigure the Wireless LAN Stand after this has been done.

Accessing the Configuration and Status of the Wireless LAN Stand

A Wireless LAN Stand can be configured as an access point or a client.

After connecting the power to the Wireless LAN Stand, it performs a self-test for about 30 seconds. After the test, the WLAN LED blinks continuously. When the self-test is finished, you can access the Wireless LAN Stand's HTML-based Configuration and Status web pages. To do this, the PC must be on the same subnet as the Wireless LAN Stand. For example, if this is a first-time configuration, the stand's factory default IP Address is 192.168.1.20. So, the PC should be configured with a static IP Address of 192.168.1.1 and a Subnet Mask of 255.255.255.0.

To access the Configuration and Status pages of the Wireless LAN Stand:

1. Configure the PC with an appropriate IP address and Subnet Mask. Make a note of the original values so you can return the PC to those settings when you are finished.
2. On the PC, open a web browser.
3. Open the home page of the Wireless LAN Stand by entering the IP address of the Wireless LAN Stand: <http://192.168.1.20>, which is the factory default, or the IP Address that the Wireless LAN Stand has been previously configured to.
4. Refer to the *Wireless LAN Stand Configuration and Engineering Guidelines* that can be found at <http://edocs.mitel.com> for explanations of the Configuration and Status pages.

Configuring and Using the IP Phone

Refer to the instructions that came with your 5200/5300 Family IP Phone to configure and use the IP Phone. You can find the instructions at <http://edocs.mitel.com>.

Federal Communications Commission (FCC) Compliance Notice: Radio Frequency Notice

This device complies with part 15 of the FCC Rules. Operation is subject to the following two conditions:

1. This device may not cause harmful interference.
2. This device must accept any interference received, including interference that may cause undesired operation.

Note: This equipment has been tested and found to comply with the limits for a Class B digital device, pursuant to part 15 of the FCC Rules. These limits are designed to provide reasonable protection against harmful interference in a residential installation. This equipment generates, uses, and can radiate radio frequency energy and, if not installed and used in accordance with the instructions, may cause harmful interference to radio communications. However, there is no guarantee that interference will not occur in a particular installation.

If this equipment does cause harmful interference to radio or television reception, which can be determined by turning the equipment off and on, the user is encouraged to try to correct the interference by one or more of the following measures:

- Reorient or relocate the receiving antenna
- Increase the separation between the equipment and receiver
- Connect the equipment into an outlet on a circuit different from that to which the receiver is connected
- Consult the dealer or an experienced radio/TV technician for help.

NOTE: This equipment is limited to operation on channels 1 - 11 when configured for use in the USA.

NOTE: Changes or modifications not expressly approved by **TeleMatrix, Inc.** may void the user's right to operate the equipment.

RF Exposures

This device has been evaluated under FCC bulletin OEC65C and found compliant to the requirements as set forth in CFR47, section 2.1091 and 15.247(b)4 addressing RF exposure from radio frequency devices.

WARNING: To ensure compliance with FCC and IC RF exposure requirements, the antenna used for this device must be installed to provide a separation distance of at least 20 cm (8 in) from all persons.

Canadian Compliance Statement

This Class B digital apparatus complies with Canadian ICES-003.

This device complies with Class B limits of Industry of Canada. Operation is subject to the following two conditions:

1. This device may not cause harmful interference.
2. This device must accept any interference received, including interference that may cause undesired operation.

This device complies with RSS-210 of Industry Canada. To prevent radio interference to the licensed service, this device is intended to be operated indoors and away from windows to provide maximum shielding. Equipment (or its transmit antenna) that is installed outdoors is subject to licensing.

Notice to Customers in EU Countries



TeleMatrix, Inc.
5025 Galley Road
Colorado Springs, CO 80915
Tel. +1.719.638.8821
Fax. +1.719.638.8815

Declare that for the hereinafter mentioned product the presumption of conformity with the applicable essential requirements of
DIRECTIVE 1999/5/EC OF THE EUROPEAN
PARLIAMENT (RTTE DIRECTIVE) AND OF THE COUNCIL
is given.

Mitel Networks Wireless LAN Stand

Any unauthorized modification of the product voids this Declaration.

For a copy of the original signed Declaration of Conformity (in full conformance with EN45014), please contact the Regulatory Approvals Manager at the above address.

NOTE: This device is restricted to indoor use when operating in France.

Important Safety Instructions and Precautions

WARNING: DO NOT CONNECT DIRECTLY TO THE PUBLIC SWITCHED TELEPHONE NETWORK (PSTN). ANY CONNECTION OF THIS UNIT TO AN OFF PREMISE APPLICATION, AN OUT OF PLANT APPLICATION, ANY OTHER EXPOSED PLANT APPLICATION, OR TO ANY EQUIPMENT OTHER THAN THE INTENDED APPLICATION MAY RESULT IN A SAFETY HAZARD, AND/OR DEFECTIVE OPERATION, AND/OR EQUIPMENT DAMAGE. "EXPOSED PLANT" MEANS WHERE ANY PORTION OF THE CIRCUIT IS SUBJECT TO ACCIDENTAL CONTACT WITH ELECTRIC LIGHTING OR POWER CONDUCTORS OPERATING AT A VOLTAGE EXCEEDING 300 V BETWEEN CONDUCTORS OR IS SUBJECT TO LIGHTNING STRIKES.

WARNING: ONLY MITEL NETWORKS APPROVED AC POWER ADAPTERS SHALL BE USED.

WARNING: THE SOCKET OUTLET, IF USED, SHALL BE LOCATED NEAR THE EQUIPMENT AND SHALL BE EASILY ACCESSIBLE BY THE USER.

WARNING: THE MITEL WIRELESS LAN STAND IS FOR USE ONLY WITH SPECIFIED MITEL EQUIPMENT.

When using your phone equipment, basic safety precautions should always be followed to reduce the risk of fire, electric shock and injury to persons, including the following:

- Do not use this product near water, for example, near a bath tub, wash bowl, kitchen sink or laundry tub, in a wet basement or near a swimming pool.
- Avoid using a phone (other than a cordless type) during an electrical storm. There may be a remote risk of electric shock from lightning.
- Do not use the phone to report a gas leak in the vicinity of a leak.

These notices may appear on the product or in the technical documentation:

DANGER	Danger indicates an imminently hazardous situation which, if not avoided, will result in death or serious injury.
WARNING	Warning indicates a potentially hazardous situation which, if not avoided, could result in death or serious injury.
CAUTION	Caution indicates a potentially hazardous situation which, if not avoided, may result in minor or moderate injury and/or damage to the equipment or property.

This symbol may appear on the product:

	The exclamation point within an equilateral triangle indicates that important operating and maintenance (servicing) instructions are included in the literature accompanying the product.
--	-------------------------------------------------------------------------------------------------------------------------------------------------------------------------------------------

Précautions et consignes importantes en matière de sécurité

AVERTISSEMENT : NE CONNECTEZ PAS VOTRE APPAREIL DIRECTEMENT AU RÉSEAU TÉLÉPHONIQUE PUBLIC COMMUTÉ (RTPC). TOUTE CONNEXION DE CE TÉLÉPHONE À UNE INSTALLATION HORS LIEUX, À UNE INSTALLATION HORS RÉSEAU, À TOUTE AUTRE INSTALLATION D'UN RÉSEAU NON PROTÉGÉ, OU À TOUT ÉQUIPEMENT AUTRE QUE LES INSTALLATIONS PRÉVUES PEUT ENTRAÎNER DES RISQUES POUR LA SÉCURITÉ, ET/OU UN FONCTIONNEMENT DÉFAILLANT, ET/OU DES DOMMAGES À L'ÉQUIPEMENT. « RÉSEAU NON PROTÉGÉ » SIGNIFIE TOUTE PORTION D'UN CIRCUIT SUJETTE À UN CONTACT ACCIDENTEL AVEC UN ÉCLAIRAGE ÉLECTRIQUE OU DES FILS ÉLECTRIQUES FONCTIONNANT SOUS UNE TENSION DE PLUS DE 300 V ENTRE LES CONDUCTEURS, OU SUJETTE À LA Foudre.

AVERTISSEMENT : SEULS LES ADAPTATEURS C.A. APPROUVÉS PAR MITEL NETWORKS DOIVENT ÊTRE UTILISÉS.

AVERTISSEMENT : LA PRISE DE SORTIE, SI ELLE EST UTILISÉE, DOIT ÊTRE INSTALLÉE PRÈS DU MATÉRIEL ET FACILEMENT ACCESSIBLE PAR L'USAGER.

AVERTISSEMENT : LE SOCLE WIRELESS LAN DE MITEL EST DESTINÉ UNIQUEMENT À L'ÉQUIPEMENT MITEL DÉSIGNÉ.

Lorsque vous utilisez de l'équipement téléphonique, observez toujours les consignes de sécurité afin de réduire les risques de feu, de choc électrique ou de blessure, notamment :

- n'utilisez pas ce produit à proximité de l'eau, par exemple près d'une baignoire, d'une cuvette, d'un évier ou d'un bac à laver, ni dans un sous-sol mouillé ou près d'une piscine;
- évitez d'utiliser un téléphone (hormis un modèle sans fil) pendant un orage. Un éclair pourrait présenter un risque de choc électrique;
- n'utilisez pas le téléphone pour signaler une fuite de gaz si vous vous trouvez à proximité de celle-ci.

Ces avis peuvent figurer sur le produit ou dans la documentation technique :

DANGER	La mention Danger indique une situation dangereuse imminente qui, si elle n'est pas évitée, entraîne la mort ou des blessures graves.
AVERTISSEMENT	Un avertissement indique une situation potentiellement dangereuse, laquelle, si elle n'est pas évitée, pourrait entraîner la mort ou des blessures graves.
MISE EN GARDE	Une mise en garde indique une situation potentiellement dangereuse, laquelle, si elle n'est pas évitée, pourrait entraîner une blessure légère ou moyenne, ou encore endommager l'équipement ou des biens.

Ce symbole peut figurer sur le produit :

	Le point d'exclamation à l'intérieur d'un triangle équilatéral indique que d'importantes consignes de fonctionnement et de maintenance (entretien courant) sont incluses dans la documentation fournie avec le produit.
------------------------------------------------------------------------------------	-------------------------------------------------------------------------------------------------------------------------------------------------------------------------------------------------------------------------

Notic aux clients canadiens

Cet appareil numérique de la classe B est conforme à la norme NMB-003 du Canada.

Précautions et consignes importantes en matière de sécurité

AVERTISSEMENT : NE LE BRANCHEZ PAS DIRECTEMENT SUR LE RÉSEAU TÉLÉPHONIQUE PUBLIC COMMUTÉ (RTPC). LA CONNEXION DE CET APPAREIL À UNE INSTALLATION HORS LIEUX OU HORS RÉSEAU, À UNE AUTRE INSTALLATION D'UN RÉSEAU NON PROTÉGÉ, OU À UN ÉQUIPEMENT AUTRE QUE LES INSTALLATIONS PRÉVUES PAR MITEL PEUT ENTRAÎNER DES RISQUES POUR LA SÉCURITÉ, UN FONCTIONNEMENT DÉFAILLANT OU DES DOMMAGES À L'ÉQUIPEMENT. "RÉSEAU NON PROTÉGÉ" SIGNIFIE TOUTE PORTION D'UN CIRCUIT SUJETTE À UN CONTACT ACCIDENTEL AVEC UN ÉCLAIRAGE ÉLECTRIQUE OU DES FILS ÉLECTRIQUES FONCTIONNANT SOUS UNE TENSION DE PLUS DE 300 V ENTRE LES CONDUCTEURS, OU SUJETTE À LA Foudre.

AVERTISSEMENT : SEULS LES ADAPTATEURS C.A. APPROUVÉS PAR MITEL NETWORKS DOIVENT ÊTRE UTILISÉS.

AVERTISSEMENT : SI ELLE EST UTILISÉE, LA PRISE DE SORTIE DOIT ÊTRE INSTALLÉE PRÈS DU MATÉRIEL ET FACILEMENT ACCESSIBLE POUR L'USAGER.

AVERTISSEMENT : LE SUPPORT WIRELESS LAN DE MITEL NE PEUT ÊTRE UTILISÉ QU'AVEC LE MATÉRIEL MITEL SPÉCIFIÉ.

Lorsque vous utilisez des équipements téléphoniques, observez toujours les consignes de sécurité afin de réduire les risques d'incendie, de décharge électrique ou de blessure, notamment :

- N'utilisez pas ce produit à proximité d'eau, par exemple près d'une baignoire, d'une cuvette, d'un évier ou d'un bac à laver, dans une cave humide ou près d'une piscine.
- Évitez d'utiliser un téléphone (hormis un modèle sans fil) pendant un orage. Un éclair pourrait présenter un risque de décharge électrique.
- N'utilisez pas le téléphone pour signaler une fuite de gaz si vous vous trouvez à proximité de celle-ci.

Ces avis peuvent figurer sur le produit ou dans la documentation technique :

DANGER	La mention Danger indique une situation dangereuse imminente qui, si elle n'est pas évitée, entraîne la mort ou des blessures graves.
AVERTISSEMENT	Un avertissement indique une situation potentiellement dangereuse, laquelle, si elle n'est pas évitée, pourrait entraîner la mort ou des blessures graves.
ATTENTION	La mention Attention indique une situation potentiellement dangereuse, laquelle, si elle n'est pas évitée, pourrait entraîner une blessure légère ou moyenne, ou encore endommager l'équipement ou des biens.

Ce symbole peut figurer sur le produit :

	Le point d'exclamation à l'intérieur d'un triangle équilatéral indique que d'importantes consignes de fonctionnement et de maintenance (entretien courant) figurent dans la documentation fournie avec le produit.
------------------------------------------------------------------------------------	--------------------------------------------------------------------------------------------------------------------------------------------------------------------------------------------------------------------

Instrucciones y precauciones de seguridad importantes

ADVERTENCIA: NO REALICE LA CONEXIÓN DIRECTAMENTE A LA RED TELEFÓNICA PÚBLICA CONMUTADA (PSTN). CUALQUIER CONEXIÓN DE ESTE TELÉFONO A UNA APLICACIÓN FUERA DEL ESTABLECIMIENTO, APLICACIÓN FUERA DE LA PLANTA, APLICACIÓN DE LA PLANTA EXPUESTA O A CUALQUIER EQUIPO DISTINTO DE LA APLICACIÓN OBJETIVO, PUEDE PROVOCAR UNA OPERACIÓN DEFECTUOSA Y/O DAÑOS EN EL EQUIPO Y/O RIESGOS A LA SEGURIDAD. "PLANTA EXPUESTA" SIGNIFICA EL LUGAR EN QUE CUALQUIER PARTE DE LOS CIRCUITOS ESTÉ EXPUESTA A UN POSIBLE CONTACTO CON RELÁMPAGOS O CONDUCTORES DE CORRIENTE QUE FUNCIONEN A UN VOLTAJE QUE EXCEDA LOS 300V ENTRE CONDUCTORES, O ESTÉ EXPUESTA A DESCARGAS ELÉCTRICAS DE RAYOS.

ADVERTENCIA: SÓLO SE USARÁN ADAPTADORES DE CA APROBADOS POR MITEL.

ADVERTENCIA: SI SE UTILIZA UN ENCHUFE DE TOMACORRIENTE, ÉSTE SE DEBE UBICAR CERCA DEL EQUIPO Y EL USUARIO DEBE TENER UN FÁCIL ACCESO A ÉL.

ADVERTENCIA: EL SOPORTE WIRELESS LAN DE MITEL ES SÓLO PARA USO CON EL EQUIPO MITEL ESPECIFICADO.

Al usar el equipo telefónico, siempre se deben tomar precauciones básicas de seguridad para reducir el riesgo de incendio, descarga eléctrica y lesiones personales, incluido lo siguiente:

- No use este producto cerca del agua, por ejemplo, cerca de una bañera, lavamanos, lavaplatos o lavadero, en un sótano húmedo o cerca de una piscina.
- Evite usar un teléfono (que no sea un teléfono inalámbrico) durante una tormenta eléctrica. Puede existir un leve riesgo de descarga eléctrica debido a rayos.
- No utilice el teléfono para informar de un escape de gas en las proximidades del mismo.

Estos avisos pueden aparecer en el producto o en la documentación técnica.

PELIGRO	Peligro indica una situación de riesgo inminente que, si no se evita, puede provocar la muerte o lesiones graves.
ADVERTENCIA	Advertencia indica una posible situación de peligro que, si no se evita, puede ocasionar la muerte o lesiones graves.
PRECAUCIÓN	Precaución indica una posible situación peligrosa que, si no se evita, puede ocasionar lesiones menores o moderadas y/o daños a los equipos o a la propiedad.

Este símbolo puede aparecer en el producto:

	El signo de exclamación dentro de un triángulo equilátero indica que se incluyen instrucciones importantes de operación y mantenimiento (servicio) en la información que acompaña al producto.
----------------------------------------------------------------------------------	------------------------------------------------------------------------------------------------------------------------------------------------------------------------------------------------

Medidas de seguridad y precauciones importantes

ADVERTENCIA: NO CONECTE DIRECTAMENTE EL TELÉFONO A LA RED TELEFÓNICA CONMUTADA PÚBLICA (RTC) CUALQUIER CONEXIÓN DE ESTE TELÉFONO A UNA APLICACIÓN AJENA A LAS INSTALACIONES O A LA PLANTA, A CUALQUIER OTRA APLICACIÓN EXPUESTA DE LA PLANTA, O A CUALQUIER EQUIPO QUE DIFIERA DEL ESTABLECIDO, PUEDE SUPONER UN RIESGO PARA LA SEGURIDAD Y/O UN FUNCIONAMIENTO DEFECTUOSO, ASÍ COMO DAÑOS AL EQUIPO. POR "PLANTA EXPUESTA" SE ENTIENDE CUALQUIER PARTE DEL CIRCUITO QUE ESTÉ EXPUESTA AL CONTACTO ACCIDENTAL CON ILUMINACIÓN ELÉCTRICA O CONDUCTORES DE ENERGÍA CON UN VOLTAJE SUPERIOR A 300 V ENTRE CONDUCTORES O QUE ESTÉ EXPUESTA A DESCARGAS ELÉCTRICAS.

ADVERTENCIA: SÓLO SE DEBEN UTILIZAR ADAPTADORES DE ALIMENTACIÓN DE CA AUTORIZADOS POR MITEL NETWORKS.

ADVERTENCIA: SI SE UTILIZA, EL ENCHUFE DEBE ESTAR SITUADO CERCA DEL EQUIPO Y FÁCILMENTE ACCESIBLE PARA EL USUARIO.

ADVERTENCIA: EL SOPORTE WIRELESS LAN DE MITEL ES PARA USO EXCLUSIVO CON EQUIPO MITEL ESPECÍFICO.

Al utilizar el equipo del teléfono, se deberán seguir las siguientes precauciones de seguridad básica en todo momento para reducir el riesgo de incendio, descarga eléctrica y daños a personas:

- No utilice este producto cerca del agua, por ejemplo, cerca de una bañera, lavabo, fregadero o lavadero, en un sótano húmedo o cerca de una piscina.
- Evite utilizar el teléfono (con excepción de los teléfonos inalámbricos) durante una tormenta eléctrica. Puede existir un leve riesgo de descarga eléctrica debido a los rayos.
- No utilice el teléfono para informar de un escape de gas en las proximidades del mismo.

Estos avisos aparecen tanto en el producto como en la documentación técnica.

PELIGRO	Peligro indica una situación de riesgo inminente que, si no se evita, puede provocar la muerte o lesiones graves.
ADVERTENCIA	Advertencia indica una posible situación de peligro que, si no se evita, puede ocasionar la muerte o lesiones graves.
PRECAUCIÓN	Precaución indica una posible situación peligrosa que, si no se evita, puede ocasionar lesiones menores o moderadas o daños a los equipos o a la propiedad.

Puede aparecer este símbolo en el producto.

	El signo de exclamación dentro de un triángulo equilátero indica que se incluyen instrucciones importantes de operación y mantenimiento (servicio) en la documentación que acompaña al producto.
-----------------------------------------------------------------------------------	--------------------------------------------------------------------------------------------------------------------------------------------------------------------------------------------------

Instruções e precauções importantes sobre segurança

ADVERTÊNCIA: NÃO CONECTE DIRETAMENTE À REDE TELEFÔNICA PÚBLICA COMUTADA (PSTN). QUALQUER CONEXÃO DESTTE TELEFONE A UMA APLICAÇÃO QUE NÃO FAÇA PARTE DAS INSTALAÇÕES, UMA APLICAÇÃO DE UMA INSTALAÇÃO EXTERNA, QUALQUER OUTRA APLICAÇÃO EXPOSTA OU A QUALQUER EQUIPAMENTO QUE NÃO SEJA A APLICAÇÃO DESTINADA A ELE PODE RESULTAR EM PERIGO DE SEGURANÇA, E/OU OPERAÇÃO DEFEITUOSA, E/OU DANOS AO EQUIPAMENTO. "INSTALAÇÃO EXPOSTA" SIGNIFICA QUE ALGUMA PARTE DO CIRCUITO ESTÁ SUJEITA A CONTACTO ACIDENTAL COM FAÍSCAS ELÉTRICAS OU CONDUTORES DE ENERGIA OPERANDO EM UMA TENSÃO QUE EXCEDA 300V ENTRE CONDUTORES OU ESTÃO SUJEITOS A RAIOS.

ADVERTÊNCIA: SOMENTE OS ADAPTADORES DE ALIMENTAÇÃO CA APROVADOS DA MITEL NETWORKS DEVEM SER USADOS.

ADVERTÊNCIA: A TOMADA, SE USADA, DEVE ESTAR LOCALIZADA PERTO DO EQUIPAMENTO E DEVE SER FÁCIL DE SER ACESSADA PELO USUÁRIO.

ADVERTÊNCIA: O SUPORTE DE WIRELESS LAN DA MITEL SERVE APENAS PARA USO COM EQUIPAMENTOS DA MITEL.

Ao usar o equipamento do telefone, sempre devem ser tomadas precauções básicas de segurança para reduzir o risco de incêndio, de choque elétrico e de danos às pessoas, incluindo o seguinte:

- Não utilize o produto próximo a água, por exemplo, perto de uma banheira, bacia de água, pia de cozinha, máquina de lavar roupas, porão úmido ou próximo a uma piscina.
- Evite usar o telefone (do tipo com fio) durante uma tempestade. Há riscos, apesar de serem remotos, de choque elétrico causado por raios.
- Não utilize esse produto para comunicar vazamento de gás próximo ao local do vazamento.

Esses avisos aparecerão no produto ou na documentação técnica:

PERIGO	Perigo indica uma situação de risco iminente que, se não for evitada, poderá resultar em morte ou ferimento grave.
ADVERTÊNCIA	Advertência indica uma situação de risco em potencial que, se não for evitada, poderá resultar em morte ou ferimento grave.
CUIDADO	Cuidado indica uma situação de risco em potencial que, se não for evitada, poderá resultar em ferimentos menores ou moderados e/ou danos ao equipamento ou à propriedade.

Este símbolo poderá estar no produto:

	O ponto de exclamação dentro do triângulo equilátero indica que instruções importantes de operação e manutenção (serviço) estão incluídas no manual que acompanha o produto.
------------------------------------------------------------------------------------	------------------------------------------------------------------------------------------------------------------------------------------------------------------------------

Instruções e precauções de segurança importantes

AVISO: NÃO LIGUE DEIRECTAMETNE À REDE TELEFÔNICA PÚBLICAS COMUTADA (PSTN). QUALQUER LIGAÇÃO DESTTE APARELHO A UMA APLICAÇÃO EXTERIOR ÀS INSTALAÇÕES, A UMA APLICAÇÃO EXTERIOR AO MATERIAL, A QUALQUER OUTRA APLICAÇÃO DE MATERIAL EXPOSTO OU A QUALQUER EQUIPAMENTO DIFERENTE DA APLICAÇÃO PLANEADA PODE PÔR EM PERIGO A SEGURANÇA E RESULTAR NUM FUNCIONAMENTO ANORMAL E/OU NUMA AVÁRIA DO EQUIPAMENTO. "MATERIAL EXPOSTO" SIGNIFICA QUALQUER PARTE DO CIRCUITO SUJEITA A CONTACTO ACIDENTAL COM RELÂMPAGOS OU CONDUTORES ELÉTRICOS, A FUNCIONAR A UMA TENSÃO SUPERIOR A 300V ENTRE CONDUTORES, OU A QUEDA DE RELÂMPAGOS.

AVISO: DEVEM SER UTILIZADOS APENAS ADAPTADORES DE CORRENTE ALTERNA APROVADOS PELA MITEL NETWORKS.

AVISO: A TOMADA, SE UTILIZADA, DEVE SER LOCALIZADA PERTO DO EQUIPAMENTO E FACILMENTE ACESSIVEL PELO UTILIZADOR.

AVISO: O MITEL WIRELESS LAN STAND DESTINA-SE APENAS A SER UTILIZADO COM O EQUIPAMENTO MITEL ESPECIFICADO.

Durante a utilização do equipamento telefónico, devem ser sempre seguidas as precauções de segurança básicas, de modo a reduzir o risco de incêndio, choque eléctrico e lesão física, incluindo as seguintes:

- Não utilize este produto perto de água, por exemplo, junto a uma banheira, lavatório, lava-loiças ou tanque de lavar roupa, sobre o chão molhado ou perto de uma piscina.
- Evite utilizar um telefone (diferente de um telefone sem fios) durante uma trovoadas com relâmpagos. Pode correr um risco remoto de choque eléctrico causado pelo relâmpago.
- Não utilize o telefone para participar uma fuga de gás nas proximidades da fuga.

É possível que os seguintes avisos apareçam no produto ou na documentação técnica.

PERIGO	"Perigo" indica uma situação eminentemente perigosa que, se não for evitada, resultará na morte ou em ferimentos graves.
AVISO	"Aviso" indica uma situação potencialmente perigosa que, se não for evitada, poderá resultar na morte ou em ferimentos graves.
ATENÇÃO	"Atenção" indica uma situação potencialmente perigosa que, se não for evitada, poderá resultar em ferimentos ligeiros ou moderados e/ou em danos materiais.

É possível que os seguintes símbolos apareçam no produto:

	O ponto de exclamação dentro de um triângulo equilátero indica que os documentos que acompanham o produto incluem instruções de funcionamento e de manutenção (reparação) importantes.
-----------------------------------------------------------------------------------	----------------------------------------------------------------------------------------------------------------------------------------------------------------------------------------

Wichtige Sicherheitshinweise und Vorsichtsmaßnahmen

WARNUNG: NICHT DIREKT AN DAS ÖFFENTLICHE TELEFONNETZ (R2) ANSCHLIESSEN. ALLE VERBINDUNGEN DIESER ANLAGE MIT EINER AUSSER-HAUS-ANWENDUNG, EINER AUSSERBETRIEBLICHEN ANWENDUNG ODER EINER ANDEREN EXPONIERTEN BETRIEBSANWENDUNG ODER ANDEREN GERÄTEN ALS DER VORGEGEHENEN ANWENDUNG KÖNNEN ZU EINEM SICHERHEITSRISIKO UND/ODER EINEM FEHLERHAFTEN BETRIEB UND/ODER EINER BESCHÄDIGUNG DES GERÄTS FÜHREN. ALS „EXPONIERTER BETRIEB“ WIRD IN DIESEM ZUSAMMENHANG DIE MÖGLICHKEIT BEZEICHNET, DASS DIE LEITUNG VERSEHENTLICH MIT BLITZ ODER STROMLEITERN KONTAKT HABEN KANN, DIE EINE SPANNUNG VON MEHR ALS 300 V ZWISCHEN LEITERN AUFWEISEN ODER IN DIE DER BLITZ EINSCHLAGEN KANN.

WARNUNG: NUR MITEL NETWORKS-WECHSELSTROM-NETZADAPTER DÜRFEN VERWENDET WERDEN.

WARNUNG: DIE STECKDOSE, FALLS VERWENDET, MUSS SICH IN DER NÄHE DES GERÄTS BEFINDEN UND FÜR DEN BENUTZER LEICHT ZUGÄNGLICH SEIN.

WARNUNG: DIE MITEL WIRELESS LAN-STATION DARF NUR MIT DER ANGEGEBENEN MITEL-AUSRÜSTUNG VERWENDET WERDEN.

Beim Einsatz Ihres Telefonapparats sollten stets grundlegende Vorsichtsmaßnahmen ergriffen werden, um die Gefahr eines Brands, elektrischen Schlags oder von Körperverletzungen auszuschließen. Dazu zählen:

- Das Produkt darf nicht in der Nähe von Wasser, z. B. in der Nähe von Badewannen, Waschschüsseln, Spülbecken oder Waschwannen, in feuchten Kellerräumen oder in der Nähe von Swimmingpools verwendet werden.
- Verwenden Sie kein Telefon (Ausnahme: Schnurlostelefone) während eines Gewitters. Ein elektrischer Schlag infolge eines Blitzschlags kann nicht ausgeschlossen werden.
- Melden Sie ein Gasleck nicht mit einem Telefon, wenn Sie sich in der Nähe des Lecks befinden.

Die folgenden Hinweise können am Produkt angebracht sein oder in der technischen Dokumentation verwendet werden.

GEFAHR	Gefahr bezeichnet eine unmittelbar gefährliche Situation, die, falls sie nicht ausgeschlossen werden kann, zum Tode oder zu einer schweren Körperverletzung führt.
WARNUNG	Warnung bezeichnet eine potenziell gefährliche Situation, die, falls sie nicht ausgeschlossen werden kann, zum Tode oder zu einer schweren Körperverletzung führen kann.
VORSICHT	Vorsicht bezeichnet eine potenziell gefährliche Situation, die, falls sie nicht ausgeschlossen werden kann, zu leichten oder mittelschweren Körperverletzungen führen und/oder Geräte oder Inventar beschädigen kann.

Das folgende Symbol kann auf dem Produkt angebracht sein:

	Das Ausrufezeichen in einem gleichschenkligen Dreieck gibt an, dass die Begleitdokumentation des Produkts wichtige Betriebs- und Wartungsanleitungen enthält.
-------------------------------------------------------------------------------------	---------------------------------------------------------------------------------------------------------------------------------------------------------------

Istruzioni e precauzioni per la sicurezza

AVVERTENZA: NON COLLEGARE IL PRODOTTO DIRETTAMENTE ALLA RETE TELEFONICA PUBBLICA COMMUTATA (PSTN). L'EVENTUALE COLLEGAMENTO DI QUESTO TELEFONO A UN'APPLICAZIONE CHE NON SI TROVI IN SEDE O ALL'INTERNO DI UN IMPIANTO O A QUALSIASI APPLICAZIONE IN UN IMPIANTO ESPOSTO O A QUALSIASI APPARECCHIATURA NON SPECIFICATA PUÒ COMPORTARE UN RISCHIO PER LA SICUREZZA E/O IL FUNZIONAMENTO DIFETTOSO E/O DANNI ALL'APPARECCHIATURA. "IMPIANTO ESPOSTO" SIGNIFICA QUALSIASI PARTE DEL CIRCUITO SOGGETTO A CONTATTI ACCIDENTALI CON CONDUTTORI DI ENERGIA ELETTRICA O ALIMENTAZIONE FUNZIONANTI A UNA TENSIONE SUPERIORE A 300 V OPPURE SOGGETTO A SCARICHE ELETTRICHE.

AVVERTENZA: UTILIZZARE ESCLUSIVAMENTE ADATTATORI CA APPROVATI DA MITEL NETWORKS.

AVVERTENZA: LA PRESA ELETTRICA DEVE TROVARSI VICINO ALL'APPARECCHIO E DEVE ESSERE FACILMENTE ACCESSIBILE ALL'UTENTE.

AVVERTENZA: L'USO DEL SUPPORTO WIRELESS LAN DI MITEL È CONSENTITO ESCLUSIVAMENTE CON APPARECCHIATURA SPECIFICA MITEL.

Quando si utilizza il telefono, occorre sempre osservare le norme di sicurezza, incluse le seguenti, al fine di evitare rischi di incendio, scosse elettriche o danni alle persone:

- Non esporre il prodotto ad acqua. Ad esempio, non utilizzarlo in prossimità di una vasca da bagno, un lavabo o un lavandino, in ambienti umidi o vicino a una piscina.
- Evitare di utilizzare il telefono (che non sia di tipo senza fili) durante una tempesta elettromagnetica. Anche se si tratta di un'eventualità remota, è possibile prendere scosse elettriche originate dai fulmini.
- Non utilizzare il telefono per comunicare una fuga di gas in prossimità del luogo in cui si è verificata la fuga.

Gli avvisi riportati di seguito possono essere riportati sul prodotto o nella documentazione tecnica.

PERICOLO	Indica una situazione altamente pericolosa che, se non evitata, può causare la morte o lesioni gravi alle persone.
AVVERTENZA	Indica una situazione potenzialmente pericolosa che, se non evitata, può causare la morte o lesioni gravi alle persone.
ATTENZIONE	Indica una situazione potenzialmente pericolosa che, se non evitata, può causare lesioni minori alle persone e/o danni materiali all'apparecchio o alla proprietà.

Questo simbolo può essere presente sul prodotto:

	Il punto esclamativo contenuto in un triangolo indica che nella documentazione fornita con il prodotto sono riportate importanti istruzioni sul funzionamento e sulla manutenzione.
------------------------------------------------------------------------------------	-------------------------------------------------------------------------------------------------------------------------------------------------------------------------------------

Belangrijke veiligheidsinstructies en voorzorgsmaatregelen

WAARSCHUWING: SLUIT DE TELEFOON NIET DIRECT AAN OP HET OPENBARE TELEFOONNETWERK (PSTN). AANSLUITING VAN DEZE TELEFOON OP EEN APPLICATIE BUITEN HET BEDRIJF OF BEDRIJFSTERREIN, EEN BLOOTGESTELDE APPLICATIE OF ANDERE APPARATUUR DAN DE BEDOELDE MITEL-APPLICATIE KAN LEIDEN TOT GEVAAR, EN/OF GEBREKKIGE WERKING, EN/OF BESCHADIGING VAN DE APPARATUUR. EEN 'BLOOTGESTELDE APPLICATIE' IS EEN APPLICATIE WAARVAN EEN DEEL VAN HET CIRCUIT ONDERWORPEN IS AAN ONVOORZIEN CONTACT MET ELEKTRISCHE VERLICHTING OF STROOMGELEIDERS MET EEN VOLTAGE VAN MEER DAN 300V TUSSEN GELEIDERS, OF ONDERWORPEN IS AAN BLIKSEMINSLAGEN.

WAARSCHUWING: GEBRUIK ALLEEN DOOR MITEL NETWORKS GOEDGEKEURDE WISSELSTROOMADAPTERS.

WAARSCHUWING: ALS U EEN STOPCONTACT GEBRUIKT, MOET HET ZICH DICHTBIJ DE APPARATUUR BEVINDEN EN MAKKELIJK BEREIKBAAR ZIJN VOOR DE GEBRUIKER.

WAARSCHUWING: HET WIRELESS LAN-BASISSTATION VAN MITEL IS ALLEEN BEDOELD VOOR GEBRUIK MET SPECIEFIEKE APPARATUUR VAN MITEL.

Tijdens het gebruik van de telefoonapparatuur moet u altijd de basisvoorzorgsmaatregelen voor veiligheid in acht nemen om het risico van brand, elektrische schok en verwondingen aan personen tot een minimum te beperken. Houd ook rekening met het volgende:

- Gebruik dit product niet in de buurt van water, bijvoorbeeld in de buurt van een bad, een wasbak, gootsteen of wastobbe, in een natte kelder of in de buurt van een zwembad.
- Vermijd het gebruik van een telefoon (behalve een draadloos model) tijdens een onweersbui. Het risico bestaat dat u een elektrische schok krijgt door blikseminslag.
- Gebruik de telefoon niet om een gaslek te melden in de buurt van een lek.

Deze kennisgevingen worden mogelijk weergegeven op het product of in de technische documentatie:

GEVAAR	Gevaar verwijst naar een dreigende gevaarlijke situatie die, wanneer deze niet wordt vermeden, de dood of ernstige verwondingen tot gevolg kan hebben.
WAARSCHUWING	Waarschuwing verwijst naar een mogelijk gevaarlijke situatie die, wanneer deze niet wordt vermeden, de dood of ernstige verwondingen tot gevolg kan hebben.
VOORZICHTIG	Voorzichtig verwijst naar een mogelijk gevaarlijke situatie die, wanneer deze niet wordt vermeden, lichte verwondingen of letsel en/of schade aan de apparatuur of eigendommen tot gevolg kan hebben.

Dit symbool wordt mogelijk op het product weergegeven:

	Een driehoek met een uitroepteken geeft aan dat de documentatie bij het product belangrijke instructies bevat voor de bediening en het onderhoud van de apparatuur.
-----------------------------------------------------------------------------------	---------------------------------------------------------------------------------------------------------------------------------------------------------------------

P/N 000-002-765 Rev E

™, ® Trademark of Mitel Networks Corporation. © Copyright 2006, Mitel Networks Corporation. All rights reserved.

™, ® Marque de commerce de Mitel Networks Corporation. © Copyright 2006, Mitel Networks Corporation. Tous droits réservés.

™, ® Marca registrada de Mitel Networks Corporation. © Copyright 2006, Mitel Networks Corporation. Todos los derechos reservados.

™, ® Marca registrada da Mitel Networks Corporation. © Copyright 2006, Mitel Networks Corporation. Todos os direitos reservados.

™, ® Marke der Mitel Networks Corporation. © Copyright 2006, Mitel Networks Corporation. Alle Rechte vorbehalten.

™, ® Marchio di Mitel Networks Corporation © Copyright 2006, Mitel Networks Corporation. Tutti i diritti riservati.

™, ® Handelsmerk van Mitel Networks Corporation. © Copyright 2006, Mitel Networks Corporation. Alle rechten voorbehoud