

# **TELEMOTIVE** *telePendant*<sup>™</sup> **TRANSMITTERS**

**RADIO**

**CONTROL**

**EQUIPMENT**

***telePendant* programming is  
found on page 20.**



**MAGNETEK**  
UNCOMMON POWER

**Telemotive Industrial Controls**

175 Wall Street  
Glendale Heights, IL 60139-1985  
Phone: 630-582-1111, Toll Free: 888-687-4400  
Website: <http://www.telemotive.com>

# **Table of Contents**

1- Service Information.....	3
2- Radio Controlled Crane Safety.....	4
3- General System Information.....	11
4- Operation.....	12
5- Programming .....	18
6- Spare Parts.....	30

# Section 1 - Service Information

## 1-1. Service Information.

For questions regarding service or technical information or ordering replacement parts, ask for Telemotive Customer Care. Telemotive's normal business hours are Monday through Friday 8:00 AM to 5:00 PM Central Standard Time. After hours emergency technical service is available.

For new product orders or quotations, ask for Telemotive Sales.

**Telemotive Industrial Controls**  
**175 Wall Street**  
**Glendale Heights, IL 60139-1985**  
**USA**

Telephone: (630) 582-1111  
In the USA toll free: (888) 687-4400

Website: <http://www.telemotive.com>  
Manuals for downloading are available for many products at the Telemotive website.

Telemotive Fax Numbers:  
Main: (630) 582-1195  
Sales: (630) 582-1204  
Customer Care: (630) 582-1205

Telemotive Industrial Control trademarks: Boommate, GateMate, 10K, *inteleSmart*, Telemotive, *telePilot*, *telePendant*, Laser Guard, Teledrive, Teltec, TeleMotion are either trademarks or registered trademarks of Telemotive Industrial Controls.

Third-party trademarks: All other trademarks, trade names or company names referenced herein are used for identification only and are the property of their respective owners.



## Section 2 – Radio Controlled Safety

### 2-1. Warnings, Cautions and Notes.

Through out this document **WARNING**, **CAUTION** and **NOTE** statements have been deliberately placed to highlight items critical to the protection of personnel and equipment.

**WARNING** – A warning highlights an essential operating or maintenance procedure, practice, etc. which if not strictly observed, could result in injury or death of personnel, or long term physical hazards. Warnings are highlighted as shown below:



**CAUTION** – A caution highlights an essential operating or maintenance procedure, practice, etc. which if not strictly observed, could result in damage to, or destruction of equipment, or loss of functional effectiveness. Cautions are highlighted as shown below:



**NOTE** – A note highlights an essential operating or maintenance procedure, condition or statement. Notes are shown as below:

### **NOTE**

**WARNINGS, CAUTIONS AND NOTES SHOULD NEVER BE DISREGARDED.**

The safety rules in this section are not intended to replace any rules or regulations of any applicable local, state, or federal governing organizations. The following information is intended to be used in conjunction with other rules or regulations already in existence. It is important to read all of the safety information contained in this section before installing or operating the Radio Control System.

### 2-2. Critical Installation Considerations.

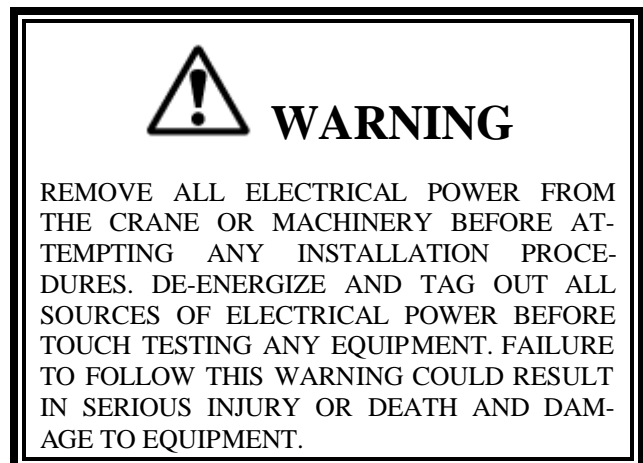
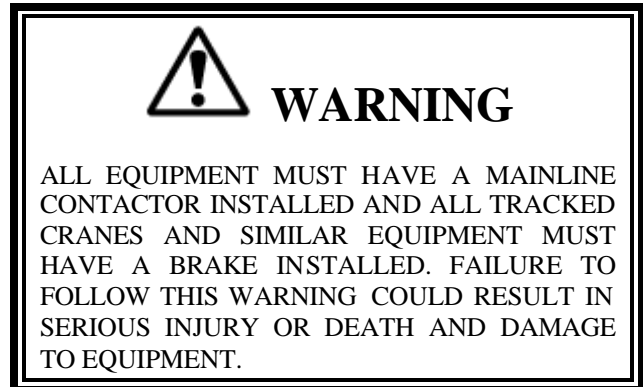

## Section 2 – Radio Controlled Safety (Continued)



### WARNING

THE DIRECT OUTPUTS OF THIS PRODUCT ARE NOT DESIGNED TO INTERFACE DIRECTLY TO TWO STATE SAFETY CRITICAL MAINTAINED FUNCTIONS, I.E., MAGNETS, VACUUM LIFTS, PUMPS, EMERGENCY EQUIPMENT, ETC. A MECHANICALLY LOCKING INTERMEDIATE RELAY SYSTEM WITH SEPARATE POWER CONSIDERATIONS MUST BE PROVIDED. FAILURE TO FOLLOW THIS WARNING COULD RESULT IN SERIOUS INJURY OR DEATH AND DAMAGE TO EQUIPMENT.

#### 2-3. General.

Radio controlled overhead cranes and other material handling equipment operate in several directions. They are large, bulky pieces of equipment that handle heavy loads efficiently at high speeds. Quite frequently, the equipment is operated in areas where people are working on the floor below. The crane operator must exercise extreme caution at all times. Workers must constantly be alert to avoid accidents. The following rules have been included to indicate how your careful and thoughtful actions may prevent injuries, damage to equipment, or even save a life. If radio controlled material-handling equipment is operated from the cab, special care must be taken to secure the transmitter. Refer to section titled Section 2-9. Boarding The Crane for specific safety rules.

#### 2-4. Persons Authorized To Operate Radio Controlled Cranes.

Only properly trained persons designated by management should be permitted to operate radio-controlled cranes.

Radio controlled cranes should not be operated by any person who cannot read or understand signs, notices and operating instructions that pertain to the crane.

Radio controlled cranes should not be operated by any person with insufficient eyesight or hearing or by any person who may be suffering from a disorder or illness or is taking any medication that may cause loss of crane control.

#### 2-5. Training Checklist for Crane Operators.

Anyone being trained to operate a radio-controlled crane should possess as a minimum the following knowledge and skills before operating the crane:

The operator should have knowledge of hazards peculiar to crane operation.

The operator should have knowledge of the safety rules for radio-controlled cranes.

The operator should have the ability to judge distance or moving objects.

The operator should have knowledge of the radio transmitter.

The operator should know the limit switch test procedure.

The operator should know, where authorized, instructions for plugging motions.

The operator should have knowledge of the use of crane warning lights and alarms.

The operator should have knowledge of observing crane signal lights.

The operator should be trained to avoid striking any obstructions.

The operator should have knowledge of the proper clearance of lifts or hooks before moving bridge or trolley.

The operator should have knowledge of the proper storage space for radio control box when not in use.

The operator should be trained in transferring radio control box to another person.

The operator should be trained how and when to report unsafe or unusual operating conditions.

The operator should be trained how to exhibit caution in approaching bridge or trolley bumpers.

The operator should know equipment capacity.

The operator should be trained in making lifts below floor level.

The operator should be trained in making side pulls.

The operator should know how to keep himself and other people clear of lifts and to avoid "pinch" points.

## ***Section 2 – Radio Controlled Safety (Continued)***

The operator should know cable and hook inspection procedures.

The operator should know procedures for testing hoist, trolley, and bridge brakes.

### **2-6. Operating Area.**

Aisles between equipment, stock, etc., should be free of obstructions so the crane operator can move freely. These aisles should be a minimum of three feet (one meter) wide, or meet local regulations.

Crane operators should always position themselves for the best view of the crane they are controlling. The crane should never be operated blindly. The operator should stay as close to the crane load as possible. Operators should never position themselves in a "pinch" point.

### **2-7. Transmitter Unit.**

Transmitter switches should never be mechanically blocked ON or OFF for any crane motion. When not in use turn the transmitter OFF. A secure storage space should be provided for the transmitter unit and the transmitter unit should always be placed there when not in use. This precaution will prevent unauthorized people from operating the crane.

Spare transmitters should be stored in a secure storage space and only removed from the storage space after the current transmitter in use has been turned OFF, taken out of the service area and secured.

Before putting the transmitter in service the transmitter unit should be inspected for any damage or excessive wear. Units with, but not limited to, any of the following: broken housings, broken or sticking switches and levers or broken handles, missing battery doors, damaged or missing switch boots or damaged or missing switch knobs should be repaired before putting into service.

### **2-8. Operating the Crane.**

#### **2-8.1. Pre-operation Test.**

At the start of each work shift, or when a new operator takes control of the crane, operators shall do as a minimum the following steps before making lifts with any crane or hoist:

Test the upper-limit switch. Slowly raise the unloaded hook block until the limit switch trips. When checking limit switches the hoist should be

centered over an area free of personnel and equipment.

Visually inspect the hook, load lines, trolley, and bridge as much as possible from the operator's station; in most instances, this will be the floor of the building.

The bridge and trolley brakes should be tested. On transmitter units equipped with two or more speeds, use the "lowest" speed when testing braking devices.

When lifting maximum loads, the crane operator should test the hoist brakes by raising the load a few inches from the floor. If the brakes do not hold, the load should immediately be lowered to the floor.

If provided, test the lower-limit switch.

Test all warning devices.

Test all direction and speed controls for both bridge and trolley travel.

Test all bridge and trolley limit switches, where provided, if operation will bring the equipment in close proximity to the limit switches.

Test the transmitter emergency stop.

Test the hoist brake to verify there is no drift without a load.

If any crane or hoist fails any of the above tests notify the supervisor and lock out and tag for repair.

#### **2-8.2. General Rules for Operation.**

Consult the crane manufacturer, local and governmental regulations for complete rules of operation. In general the following rules apply to remotely controlled cranes:

The limit switches should never be used as a regular stopping device. They are intended to be protective devices.

Do not make lifts in excess of the equipment rated capacity.

The bridge and trolley should be centered directly over the load when the load is raised to prevent swinging when making lifts.

A crane designed for this purpose and only with supervisor permission should make side pulls. When a lift is being made, the crane operator should not be

## ***Section 2 – Radio Controlled Safety (Continued)***

positioned in the line of travel. The crane or hoist should be operated from a position either to the side or opposite from the direction of travel.

When raising or lowering a load, proceed slowly and make certain the load is under control. Tag lines should be used for handling unusual lengths or bulky loads. Remove slack from chains or slings gradually. Make certain all personnel are clear before making a lift.

The crane operator should keep all body parts away from the lift and should never be positioned under the lift.

Do not make a lift or move a load if anyone is in a location where they could be struck by the crane or the load.

If the crane operator is being helped, the crane should not be moved until the helper signals they are clear of the crane and its load.

When a load is hanging from the crane hook and the crane is being moved, the crane operator should sound all warning devices frequently.

Loads should not be carried over workers heads. If a worker is in the path of crane travel, the crane operator should stop the crane and clear the area before proceeding.

Runway stops or other cranes should never be bumped into.

When moving the crane, the crane operator should be sure that the hook block and attachments or cables would not catch on nearby equipment. Slings, chains, or cables should never be dragged along the floor.

Unless required for operator safety, gloves should not be worn when operating the transmitter unit.

All loose materials or parts should be removed from the load before starting the lift.

The crane operator should always hoist lifts high enough to clear all equipment and workers.

The crane operator should never permit anyone to ride on the load or hook except when authorized by the supervisor.

When another crane on the same runway is stationary with a load hanging, the crane operator should maintain a safe distance between the stationary crane and the one under their control.

Never leave suspended loads unattended. In an emergency, if the crane is inoperative and a load suspended, notify the supervisor immediately, barricade and post signs on the floor beneath crane and load.

If power to the crane is removed, the crane operator should turn the transmitter unit OFF and keep it OFF until power is restored.

If the crane fails to respond properly, the crane operator should stop operation, turn the transmitter unit OFF and immediately report the condition to their supervisor.

Outdoor cranes, which are subject to movement by wind, should be securely anchored when left unattended. If the crane is equipped with bridge brakes, the parking brake should be set immediately.

### **2-9. Boarding the Crane.**

The crane should not be boarded without permission of the supervisor.

The crane operator should turn off the transmitter and take it with them when boarding the crane.

If more than one person is boarding the crane, one person should be made responsible for ensuring all personnel are off the crane before the system is returned to operation.

### **2-10. Crane Maintenance and Repair.**

Qualified personnel must maintain a regularly, i.e., such as monthly, scheduled crane inspection. During this crane inspection the functionality and safety of the crane remote control must also be tested. The inspection shall include, but be not limited to items listed in Section 2-12. Condition of the Radio Controlled Crane. Consult crane manufacturer, local and governmental regulations for recommended inspection intervals and proper inspection procedures. Problems noted during this inspection must be repaired before using the crane or the remote control.

Minor repairs include routine maintenance and repairs such as greasing, cleaning and control troubleshooting. All other repairs should be considered major. If the repair crew consists of more than one person, one person should be designated as the repair crew leader with the following responsibilities. If the repair crew consists of only one person, that person has the following responsibilities:

## ***Section 2 – Radio Controlled Safety (Continued)***

For minor repairs warning signs should be placed on the floor beneath the crane or suspended from the crane. For major repairs, the floor area below the crane should be roped off.

When major repairs are to take place, all persons operating other cranes on the same or adjacent runways, if any, must be notified prior to starting repairs. Notification should include the nature of the repair, safeguards provided, and movement limitations while repairs are in progress.

When practical, radio controlled cranes which cannot be moved during repairs must be protected against being bumped by other cranes on the runway. Bumpers should be installed on the exposed side or sides of the crane under repair. They should be placed as far away as possible. The location of these bumpers should be indicated by red lights placed so that they are clearly visible to other crane operators traveling on the same runway. When it is not possible to use bumpers, red lights must be placed so they are clearly visible to other crane operators traveling on the same runway to indicate the restricted travel zone. All crane operators on the same runway must be informed of the repair effort and thoroughly instructed to what their operations are limited to and informed they will be notified when repairs are completed.

If any hazard involving the repairmen exists when there is a runway adjacent to the crane under repair, the adjacent runway should be blocked off as described above. When it is necessary to continue crane operation on the adjacent runways warning lights must be installed and be visible to operators of cranes on those runways. All cranes should come to a complete stop prior to entering the restricted area and should proceed through this area only after receiving permission from a signal person designated for this purpose. Access of persons to and from the crane being repaired should be under control of the repair crew leader.

When boarding the crane, the transmitter should be turned OFF and the transmitter should remain with the repair crew leader. The leader should board the crane first, open and lock out the main switch, and then signal the other members of the crew it is safe to board the crane.

If work on the crane is to be done in areas not protected by standard handrails, the repair crew should wear approved safety belts.

All tools and equipment should be moved onto the crane by the use of hand lines. The tools and equipment should be adequately secured to the hand lines.

If it is necessary to have the crane control circuits energized, all power circuits for crane movement must be opened prior to energizing the control circuits.

All personnel and tools should be moved to a safe spot before moving the crane during repairs.

Headroom is at a minimum in some crane cabs and on some crane walkways. Caution should be exercised when boarding or working on cranes. Hard hats should be worn whenever possible.

When repairs are finished, all personnel, tools and repair equipment should be removed before energizing the crane circuits.

### **2-11. Using the Crane as a Work Platform.**

When the crane is to be used as a stationary work platform, follow all rules provided in Section 2-10. Crane Maintenance and Repair. When it is necessary for the crane to be moved from time to time, the crane operator should board the crane with the transmitter unit. The crane operator should ensure all personnel working on the crane are in a secure position before moving the crane to the next workstation. It should also be the crane operator's responsibility to ensure the main switch is open and locked down before work is resumed.

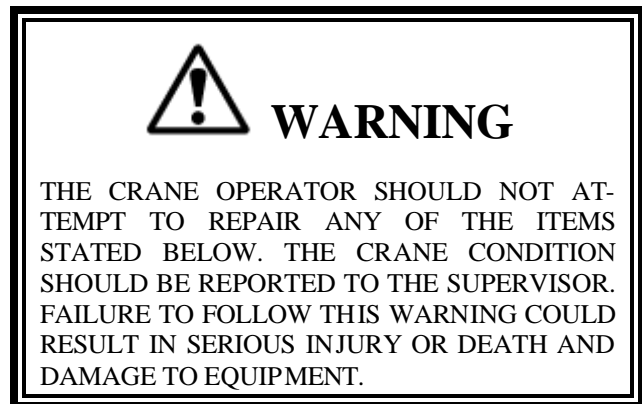

### **2-12. Condition of the Radio Controlled Crane.**

If the crane fails to respond properly, the crane operator(s) should notify their supervisor. When serious conditions are noticed (conditions that make the crane unsafe to operate), the crane should be shut



## ***Section 2 – Radio Controlled Safety (Continued)***

down immediately and the supervisor notified. The following is a list of some of the items that should be included in the report. (See the crane manufacturer for specifics and possible additional items):

Condition of hoisting cable and hook block (broken strands, clipped sheave wheels, etc.).

Condition of brakes (hoist, trolley, and bridge). (No bluing, rivets on shoes showing, glazing, etc.).

Condition of trolley and rail stops.

Condition of bridge structure.

Condition of festoon system.

Broken welds in any part of the crane structure.

Proper fluid levels and lubrication.

Condition of bridge and trolley stops.

Carbon dust or signs burning on the covers of motors.

Indication of fluid, oil or grease leaks.

Condition of rail sweeps.

Walkways required handrails and ladders are in place, sturdy and not loose.

Protective guards are in place for all moving parts.

Alignment of bridge (screeching or squealing wheels indicate bridge is out of line).

Broken, cracked, or chipped rails on trolley or runway.

Condition of limit switches.

Condition of electrical and mechanical control (electrical or mechanical defects which cause faulty operation such as un-commanded stopping or starting of any crane motions, warning devices, lights, or auxiliary functions).

Condition of gears (grinding or squealing may indicate foreign materials in gear teeth or a lack of lubrication).

All controls especially E-STOPS are in place and in working order.

Frequent relay tripping of power circuits.

Mechanical parts loosened by vibration (loose rivets, covers, bolts, etc.).

Uneven riding (worn or damaged wheels).

Condition of collector shoes or bars.

Condition of warning or signal lights and horns. (Burned out or broken).

### **2-13. Batteries**

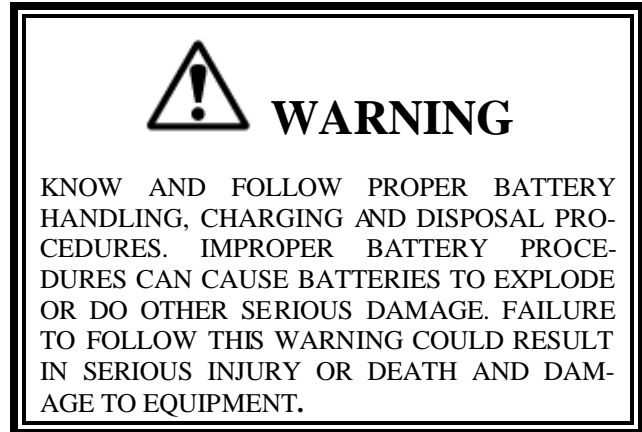

#### **2-13.1. Battery Handling.**

Use only batteries approved by Telemotive for the specific product.

Do not dispose of a battery pack in fire; it may explode.

Do not attempt to open the battery pack.

Do not short circuit battery.

Do not attempt to use a battery that is leaking, swollen or corroded.

For intrinsically safe environments only use specified Telemotive intrinsically safe batteries.

Keep the battery pack environment cool during charging operation and storage, (i.e., not in direct sunlight or close to a heating source).

Do not submerge battery in water.

If battery leaks avoid contact with electrolyte.

## ***Section 2 – Radio Controlled Safety (Continued)***

### **2-13.2. Battery Charging.**

For those transmitters equipped with battery chargers, please familiarize all users with the instructions of the charger before attempting to use.

Use only Telemotive approved chargers for the appropriate battery pack.

Do not attempt to charge non-rechargeable battery packs.

Avoid charging the battery pack for more than 24 hours.

Do not charge batteries in a hazardous environment.

Do not short charger.

Do not attempt to charge a damaged battery.

Charger units are not intended for outdoor use. Use only indoors.

Always unplug the charger when not in use.

Do not store, place or use the charger where it could come into contact with water or moisture.

To reduce the risk of electric shock, unplug your charger from the wall outlet before cleaning.

### **2-13.3. Battery Disposal.**

Before disposing of batteries consult local and governmental regulatory requirements for proper disposal procedures.

# **Section 3 – General System Information**

## **3-1. General System Information.**

The Telemotive Radio Control System (system) provides remote control of overhead cranes using radio signals. The system consists of a hand held portable battery operated transmitter unit and a fixed station receiver unit.

A unique 16-bit code (Access Code) for each system is preset in every transmitter and receiver. The receiver considers any received signal, which does not match the receiver access code setting, invalid. The Access Code is made up of 16-bits (65,000 combinations) and no two similar codes are assigned to any two Telemotive systems.

Up to four systems may be used with the same frequency in a 600-foot area (220 meters). Each transmitter operating on the same frequency may be operated in close proximity, not less than six feet (1.9 meters), to each other.

## **3-2. TMS Low Power Signaling.**

TMS (Time Multiplexed Signaling) is a Telemotive proprietary high-speed packet data system. The system software is structured to minimize "on the air" transmission time of any transmitter. This allows for multiple transmitters to share a common frequency. The TMS system is designed so that a transmitter will send a signal for a predetermined ON time, and then will turn OFF. The length of transmitter ON time is referred to as data burst or packet. The packet length is a function of the quantity of data to be sent, and the data rate (baud). Once the packet is sent, the transmitter will turn OFF. This allows for other transmitters to time-share the same frequency when a transmitter has turned OFF. The TMS system software determines the OFF period and repetition rate of the ON period. Since each system has its own access code, up to 4 transmitters can share and have equal access to the same frequency. TMS also allows for reduced battery consumption and extended battery life.

These systems have low power pulsed signaling, FCC certified under Part 15 Telecommunications Code of Regulations, no license is required. The transmitter unit is frequency modulated, low power and is certified under the appropriate regulations. A license is not required for the transmitter or operator. Modifications to the RF section of this system are not permitted and could void FCC certification.

Active ESTOP (optional), this feature causes the transmitter to send confirmation that the ESTOP is

not being engaged via a periodic confirmation signal. Units so equipped will shut down the receiver when out of range.

## **3-3. Channel Designations:**

AK01 - 439.8 MHz	AK06 - 438.8 MHz
AK02 - 439.6 MHz	AK07 - 438.6 MHz
AK03 - 439.4 MHz	AK08 - 438.4 MHz
AK04 - 439.2 MHz	AK09 - 438.2 MHz
AK05 - 439.0 MHz	AK10 - 438.0 MHz

AK11 - 437.8 MHz	AK16 - 436.8 MHz
AK12 - 437.6 MHz	AK17 - 436.6 MHz
AK13 - 437.4 MHz	AK18 - 436.4 MHz
AK14 - 437.2 MHz	AK19 - 436.2 MHz
AK15 - 437.0 MHz	AK20 - 436.0 MHz

AKA00 - 433.125 MHz	AKA05 - 434.125 MHz
AKA01 - 433.325 MHz	AKA06 - 434.325 MHz
AKA02 - 433.525 MHz	AKA07 - 434.525 MHz
AKA03 - 433.725 MHz	AKA08 - 434.725 MHz
AKA04 - 433.925 MHz	

## **3-4. Transmitter Specifications.**

Transmitter housing: NEMA 4.

Operating Temperature: -22° F to +158° F (-30° C to +70° C) ambient.

Humidity: up to 95 % (non-condensing).

Typical Operating Range: 200 feet (70 meters).

## **3-5. Transmitter Unit.**

The transmitter is battery operated, has an ON and OFF switch, E-STOP, motor controls and auxiliary controls used for such item warning indicators.

LED's mounted on the front panel provide indication of battery voltage, ON/OFF, Modes and data transmission status.

A power down feature allows the transmitter and the receiver unit to turn OFF if no keys are pressed for predetermined number of minutes. The transmitter unit must again be turned ON. The unit uses pulsed operation for extremely long battery life. A configuration of the system is available without automatic timeout.

Housings are designed of high impact, chemical resistant, materials. The antenna for the unit is internal. A strap is provided for carrying the transmitter.

# Section 4 – Operation

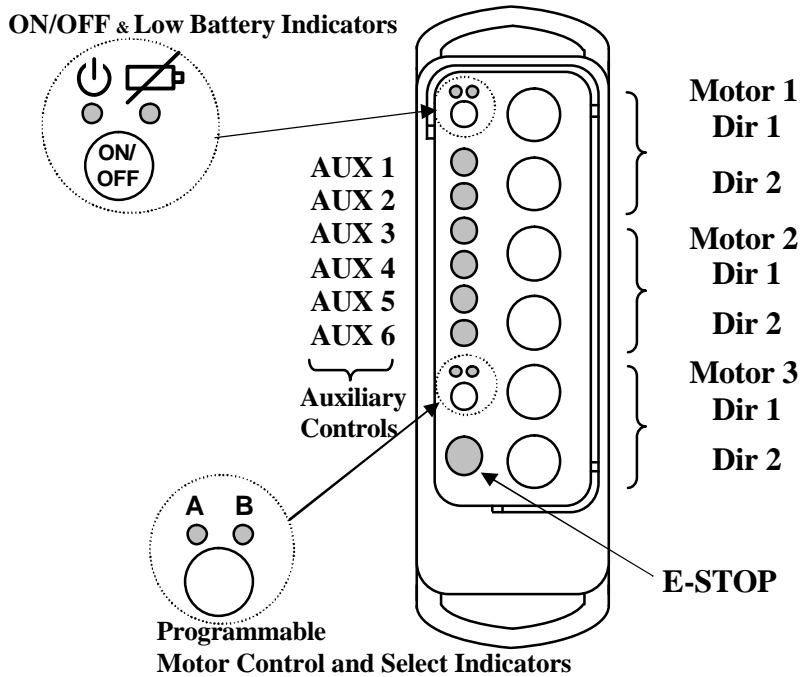

**Figure 4-1. 2- and 3-Speed telePendant**

### 4-1. Transmitter Buttons.

**ON/OFF** On the *telePendant* Transmitter ON and OFF is the same button. This button toggles between turning the transmitter ON and then sending the ON command to the receiver and sending the OFF command to the receiver and then turning the transmitter OFF. Press and hold the button for one full second to turn the unit ON.

Labels are provided for the auxiliary buttons and the labeled pushbutton boots can be unsnapped and moved to reflect the desired labeling. Custom labels are available from Telemotive.

**NOTE**

IN THE TELEPENDANT THE TRANSMITTER DOES NOT TURN ON TILL THE ON PUSH BUTTON IS RELEASED AFTER BEING DEPRESSED FOR ONE SECOND. THE OFF FUNCTION IS IMMEDIATE UPON DEPRESSING THE ON/OFF PUSH BUTTON.

**E-STOP** – Stops all equipment movement and disables all functions except Alarm. Reset the system for normal operation by turning the transmitter “OFF” then “ON”. Use for

emergencies only. (NOT FOR NORMAL SHUT DOWN).

**NOTE**

ON THE TELEPENDANT TRANSMITTER THE USER CAN CHOOSE AND CUSTOM LABEL THE FUNCTIONS FOR A SPECIFIC MOTOR. THE FUNCTIONAL DESIGNATIONS SHOWN BELOW ARE COMMON AND TRADITIONAL DESIGNATIONS.

**Common Designations Listed Below:**

**Motor 1 Dir 1, UP** – Selects hoist movement in the UP direction speed one (first switch position), speed two (second switch position). Or speed three (third switch position if so equipped).

**Motor 1 Dir 2, DOWN** – Selects hoist movement in the DOWN direction speed one ((first switch position), speed two (second switch position). or speed three (third switch position if so equipped).

**Motor 2 Dir 1, NORTH or EAST** – Selects the appropriate direction of the bridge or trolley (depending how unit is wired at installation) speed one (first switch position), speed two

## Section 4 – Operation (Continued)

(second switch position). Or speed three (third switch position if so equipped).

**Motor 2 Dir 2, SOUTH or WEST** – Selects the appropriate direction of the bridge or trolley (depending how unit is wired at installation) speed one (first switch position), speed two (second switch position). Or speed three (third switch position if so equipped).

**Motor 3 Dir 1, EAST or NORTH** – Selects the appropriate direction of the bridge or trolley (depending how unit is wired at installation) speed one (first switch position), speed two (second switch position). Or speed three (third switch position if so equipped).

**Motor 3 Dir 2, WEST or SOUTH** – Selects the appropriate direction of the bridge or trolley (depending how unit is wired at installation) speed one (first switch position), speed two (second switch position). Or speed three (third switch position if so equipped).

### 4-2. Programmable Motor Control and Select Indicators.

A B  
○ ○

This programmable pushbutton can be designated as an auxiliary motor or select function. As an example for systems that have a main and auxiliary hoist, pushing this switch will toggle the function of the set of motor 1 pushbuttons between the outputs for main and auxiliary hoist.

There are two red LEDs above this pushbutton labeled “A” and “B”. The “A” LED comes ON for the main function and the “B” comes ON for the auxiliary. As the pushbutton is toggled the sequence of outputs and LEDs is as follows. Normally the main output only is active and the “A” LED is lit. Pushing the pushbutton lights only the “B” LED and the auxiliary output only is active. Pushing the pushbutton a second time lights both “A” and “B” LEDs and both main and auxiliary outputs are active in tandem. (This tandem operation can be disabled See Section 5-3.2. *telePendant* Programming). When turning the transmitter ON the default condition is always “A”.

This pushbutton can be used with the Select function also. When used for the Select function the “A” and “B” LEDs work as described in the above paragraph toggling the Select 2 output and the Select 1 outputs respectively.

### NOTE

THE “A” LED LIT CAUSES THE SELECT 2 RELAY TO CLOSE. THE “B” LED CAUSES THE SELECT 1 RELAY TO CLOSE.

For *telePendants* with four or five motors programmed, this indicator will toggle between “A,” “B” and both (for units programmed with or without tandem operation). Pressing the push button directly beneath the indicators toggles the state.

**AUX’s 1 through 6** – Selects the Auxiliary relay(s), which may be used for a warning device as a horn or other function. Check the receiver manual to determine how many auxiliaries are available, some have the ability to be programmed to be latching.

### ON/OFF LED Indicator.

Top left indicator on *telePendant*. When the transmitter is ON the red LED flashes slowly. When the unit transmits, the red LED flashes rapidly. This LED also indicates Bank selected.

### 4-3. Low Battery Indication.

In the *telePendant* transmitter there is a separate low battery indicator located to the right of the ON/OFF indicator. This is a yellow LED that turns ON solid when it is time to replace the batteries. See Section 4-6. Battery Replacement for battery replacement.



## WARNING

BEFORE TURNING ON OR OPERATING THE CRANE, MAKE SURE ALL PERSONNEL ARE CLEAR OF THE OPERATING AREA AND NO ONE IS STANDING UNDER THE LOAD. FAILURE TO FOLLOW THIS WARNING COULD RESULT IN SERIOUS INJURY OR DEATH AND DAMAGE TO EQUIPMENT.

## Section 4 – Operation (Continued)



### WARNING

WHEN OPERATING THE CRANE FOLLOW LOCAL AND GOVERNMENTAL RULES ON THE USE OF HORNS AND ALARMS. FAILURE TO FOLLOW THIS WARNING COULD RESULT IN SERIOUS INJURY OR DEATH AND DAMAGE TO EQUIPMENT.

#### 4-4. Operation.

Make sure that all personnel are clear of the crane movement and no one is under the crane or load.

Turn unit ON by pressing the ON/OFF (ON) button. The red LED ON/OFF indicator should flash rapidly for a few seconds indicating the ON command is being sent to the receiver. After the receiver is turned ON the red LED should flash slowly indicating the transmitter is now ready to send commands.

Perform whatever safety checks are required. See Section 2. Radio Controlled Safety. Operate any horns or alarms as required by local and governmental regulations.

To operate the crane, press and hold the desired function button to maintain operation. Press the directional buttons harder to second position to engage second speed for those cranes having 2-speed motors.

Always turn system OFF by pressing the ON/OFF (OFF) button on the transmitter when done with crane operation. Do not use the E-STOP button as an ON/OFF button.

In an emergency always hit E-STOP (EMS) immediately. To clear the emergency condition, turn the transmitter OFF and ON again to resume normal operation.

Typically the receiver will time-out after approximately 15 minutes if there is no activity. The transmitter can be programmed to time-out if not used for some number of minutes. The transmitter time out time is selectable.



### WARNING

IN AN EMERGENCY HIT “E-STOP” TO STOP ALL CRANE MOVEMENT. WHEN EMERGENCY HAS CLEARED TURN THE TRANSMITTER OFF THEN ON AGAIN TO RESUME NORMAL OPERATION. FAILURE TO FOLLOW THIS WARNING COULD RESULT IN SERIOUS INJURY OR DEATH AND DAMAGE TO EQUIPMENT.

#### 4-5. Additional *tele*Pendant Transmitter Operational Features.

##### *tele*Pendant E-STOP Function.

The E-STOP command will be repeatedly sent as long as the E-STOP pushbutton is depressed. The E-STOP is always live on the *tele*Pendant transmitter. Upon pushing the E-STOP pushbutton the transmitter will send an E-STOP command for the last selected Bank even if the unit is turned OFF. (Obviously, if the battery is dead this will not work).

##### *tele*Pendant Self-Test Function.

When the unit turns on if any function key is depressed the unit will fault, not send a turn on command and not become operational. The red LED will stay ON till the unit is turned OFF. The unit will frequently scan the 2<sup>nd</sup> position of the motion switches while the transmitter is ON and if one of these is closed without the first position closed, the unit will fault as above.

##### *tele*Pendant Red LED ON/OFF Indicator.



The red LED, at the upper most left hand side of the transmitter, operates as follows:

- Be OFF when the transmitter is OFF.
- Flash slowly when the transmitter is ON, but not transmitting. If the transmitter has Bank select enabled there will be a number of quick flashes followed by a pause. The number of quick flashes indicates the Bank the transmitter is in.

## Section 4 – Operation (Continued)

- Flash rapidly when the transmitter is transmitting, including during E-STOP when the transmitter is OFF.
- Remain ON continuously for: waiting password, un-programmed Bank selected or a logic or pushbutton fault.

### telePendant Low Battery Shutoff Function.

If the battery gets too low the unit will shut off and send an OFF command to the receiver as it turns OFF.

### telePendant Battery Yellow Indicator Light.



The yellow LED to the right of the ON/OFF indicator operates as follows:

- Be OFF when the transmitter is OFF.
- Be OFF when the transmitter is ON and the battery is good.
- Remain ON continuously for a low battery needing replacement.



### telePendant Bank Select (Normally Password Protected).

This feature is like having four completely different transmitters in one unit. Up to four banks (operational configurations) are possible. A fifth bank is reserved for programming, this Bank is not password protected. A Bank is a specific configuration of user-defined parameters including:

System type  
Frequency  
Access codes

Also: Key arrangement  
Relay configuration  
Time-out-timer time  
Mode selection  
Alarm settings

To select a specific bank: **With the transmitter turned OFF**, the ON/OFF push button is then pressed and held down while one of the five upper most motion push buttons (buttons 1 through 5 see Figure 4-2. Bank and Password Input Buttons) is pressed. Press push button 1 for Bank 1, push button 2 for Bank 2, push button 3 for Bank 3, push button 4 for Bank 4 or push button 5 for Bank 5 the programming bank. While the Bank button is held down release the ON pushbutton and then the Bank button. (The

sequence is important). The transmitter red LED ON/OFF  indicator then stays ON (for five seconds) till the password is entered. Once the password is entered (see below) the transmitter red LED ON/OFF  indicator flashes indicating the current Bank the operator is in while the transmitter is ON and not transmitting. One flash then a pause repeatedly indicates Bank 1, two quick flashes indicates Bank 2, three quick flashes and a pause indicates Bank 3 and so on. The transmitter will remember what Bank it is in even if turned OFF and ON again.

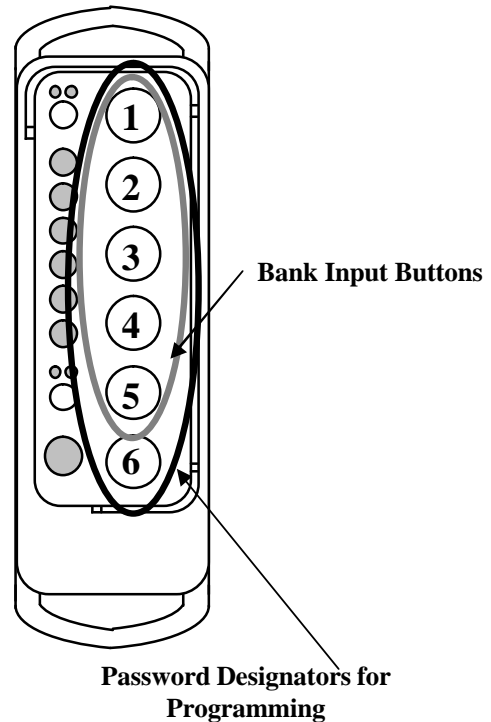



Figure 4-2. Bank and Password Input Buttons.

It is not necessary to program all four Banks, if an un-programmed or turned “off” Bank is selected the ON/OFF  indicator will remain ON continuously, the transmitter will send no commands and will turn itself off shortly.

### telePendant Bank Password Protection Function.

This enables the owner to create a four-stroke password word to enable changing Banks. With Password enabled the operator selects a four-button sequence to enable a Bank after different Bank has been selected (see above). When the

## Section 4 – Operation (Continued)

transmitter is turned ON, after Bank Selection is made and the ON/OFF  indicator will remain lit until the correct password sequence is entered within five seconds. An incorrect password sequence or failure to enter the sequence in time shuts the unit OFF. The user is allowed to restart and try again an unlimited amount of times. The Bank Password is the same for all four Banks.

**WARNING**

THIS PASSWORD FUNCTION IS NOT TO BE USED AS A SECURITY DEVICE. THE PURPOSE OF THIS FUNCTION IS TO PREVENT ACCIDENTAL BANK SWITCHING. THE BEST FORM OF SECURITY IS ALWAYS TO LOCKUP THE TRANSMITTER WHEN NOT IN SERVICE. FAILURE TO FOLLOW THIS WARNING COULD RESULT IN SERIOUS INJURY OR DEATH AND DAMAGE TO EQUIPMENT.

When initially programming the unit the default password is 6, 5, 4, 3. This password can be easily changed by the PDA during initial programming.

A password is a sequence of four pushbutton entries. These entries are any combination of inputs from the upper most six buttons on the right hand side of the *telePendant* transmitter. On 2- and 3-Speed transmitters the second and third speed is ignored.

Acceptable sequences could duplicate button numbers such as 2, 2, 6, 6 or 1, 1, 1, 4.

### NOTE

ALWAYS REMEMBER TO STORE THE PASSWORD IN A SECURE LOCATION FOR ACCESS IF THE PASSWORD IS LOST OR FORGOTTEN. ONCE THE TRANSMITTER IS PROGRAMMED THERE IS NO WAY TO DEFEAT THE PASSWORD WITHOUT USING A PDA TO EITHER READ THE PASSWORD OUT OR REPROGRAM A NEW ONE.

The Bank password can be disabled during initial programming by the PDA.

**WARNING**

DISABLING THE PASSWORD FUNCTION PUTS THE SYSTEM IN ACTIVE BANK SELECT. THIS ALLOWS THE CRANE OPERATOR TO SWITCH BETWEEN BANKS QUICKER. THE OPERATOR IN THIS MODE MUST BE AWARE AND RESPONSIBLE FOR ALL POSSIBLE CONTROLLED CRANES. FAILURE TO FOLLOW THIS WARNING COULD RESULT IN SERIOUS INJURY OR DEATH AND DAMAGE TO EQUIPMENT.

### *telePendant* Time-Out-Timer Function.

The transmitter has a time-out timer and the default condition is 15 minutes. Upon timing out the transmitter will send an OFF command to the receiver if Auto Turn Off is active. The transmitter time-out-timer function is programmable in minute increments to up to and including 15 minutes. After that it is programmable in five-minute increments up to and including one hour. Infinite time-out (none) is also selectable. The time-out-timer measures the time since the last pushbutton stroke and is continuously reset by any pushbutton activation.

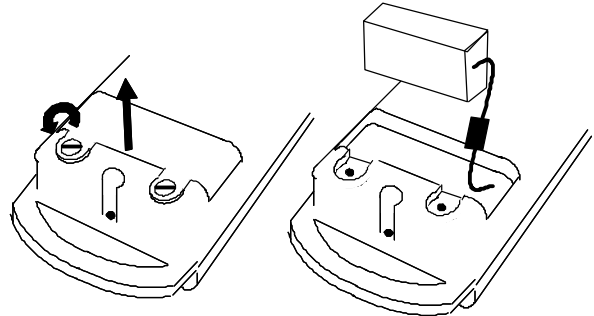



Figure 4-3. *telePendant* Battery Replacement.

### 4-6. Battery Replacement.

#### *telePendant* Battery Replacement.

On the *telePendant* if the yellow battery indicator light  starts to flash replace the battery at the earliest opportunity. If the light is on solid replace the battery immediately.



## Section 4 – Operation (Continued)

### NOTE

THERE IS NO NEED TO RUSH BATTERY REPLACEMENT. THE PROGRAMMING IN THE *TELEPENDANT* WILL **NOT** BE LOST BY REMOVAL OF THE BATTERY OR PROLONGED LOSS OF POWER.

Turn the transmitter OFF, loosen the two coin-screws on the bottom of the unit with a small coin and remove the bottom door. (See below). Pull out the battery holder until the batteries can be accessed. Do not pull hard on the battery holder as it is attached to the logic board by a cable.

For a **battery carrier with two “AA” cells**, replace the two “AA” cell batteries with new batteries, noting the polarity for “AA” cells marked on the holder. (Best life can be obtained if the two “AA” batteries used are new, a good quality alkaline type, both cells of the same type and from the same manufacturer). Accidentally putting the batteries in the wrong direction will not damage the unit.

For **battery packs**, unlatch the battery cable by pressing or squeezing the locking tab on the battery connector and pulling apart, pulling on the connector housings, not the wires. (see Figure 4.4 below). Slide the new battery pack connector into place until the connector latches.

After replacing the battery(s) place the battery back inside the transmitter, replace the battery door and tighten the thumbscrews. See Section 6 – Spare Parts, for battery part numbers.

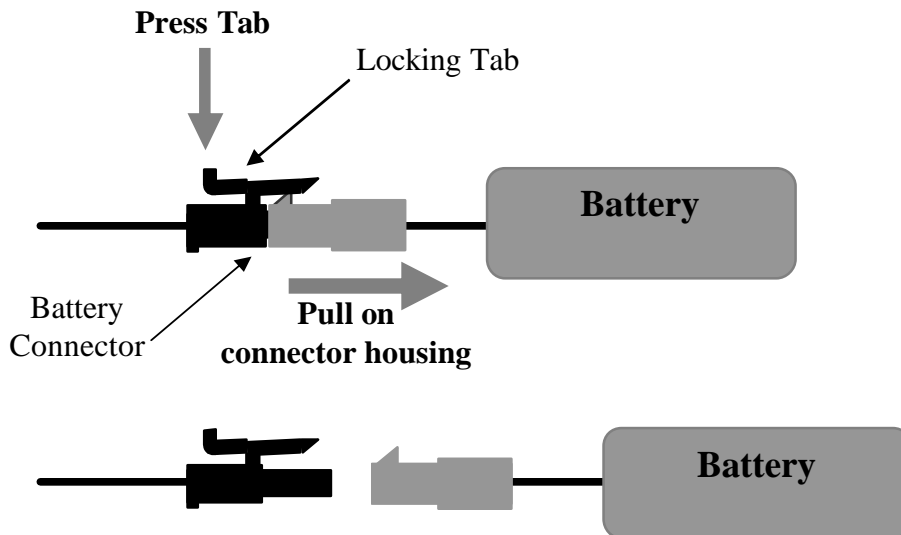
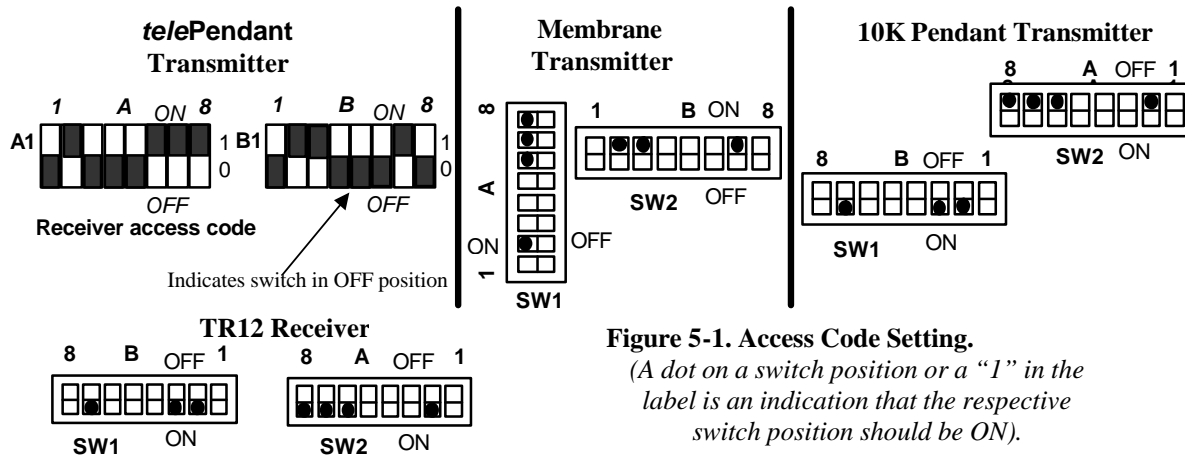

Figure 4.4 Disconnecting the battery.

# Section 5 – Programming

## 5-1. Access Codes.



**Figure 5-1. Access Code Setting.**  
 (A dot on a switch position or a “1” in the label is an indication that the respective switch position should be ON).

**Access Code Switches**  
Sample access code only, do not use

MODEL # -10KXXXXXXXXX  
 S/N=XXXXXXXXXXXXXXXXXX  
 ACCESS CODE SETTING  
**1    A    8            1    B    8**  
 0 1 0 0 0 1 1 1            0 1 1 0 0 0 1 0  
 FREQ := AK01      J# = XXXXX

**Sample Membrane or Pendant Transmitter**  
**Access Code Label**  
Sample access code only do not use

### 5-1.1. Programming Access Codes.

The access code is set at the factory and should not be changed unless absolutely necessary. If you are reprogramming a spare or new transmitter make sure the other transmitter is securely taken out of service.



## WARNING

TWO OPERATIONAL TRANSMITTERS WITH THE SAME ACCESS CODES OPERATING AT THE SAME TIME IS A DEFINITE SAFETY HAZARD. FAILURE TO FOLLOW THIS WARNING COULD RESULT IN SERIOUS INJURY OR DEATH AND DAMAGE TO EQUIPMENT.

### 5-1.2. Changing Transmitter Access Codes.

#### 5-1.2.1. telePendant Access Code Programming.

For detailed instructions on setting parameters including access codes see Section 5-3.2. telePendant Programming.



## WARNING

AFTER CHANGING THE ACCESS CODES ON THE TRANSMITTER, TEST THE UNIT BY TURNING IT ON AND OFF NEAR THE APPROPRIATE RECEIVER. IF THE RECEIVER DOES NOT RESPOND, DO NOT ACTIVATE A FUNCTION BUTTON! THE TRANSMITTER MAY HAVE THE WRONG ACCESS CODE, WHICH COULD MOVE ANOTHER CRANE. RE-CHECK THE ACCESS CODE IN THE TRANSMITTER AND RETEST. FAILURE TO FOLLOW THIS WARNING COULD RESULT IN SERIOUS INJURY OR DEATH AND DAMAGE TO EQUIPMENT.

#### NOTE

IN EVENT PROGRAMMING OF ACCESS CODES IS REQUIRED, TAKE SPECIAL CARE TO CORRECTLY LOCATE ACCESS CODE SWITCHES A AND B. LOOK FOR THE LABELS A AND B ON

## Section 5 – Programming (Continued)

THE PRINTED CIRCUIT BOARD NEAR THE RESPECTIVE SWITCHES. DETERMINE THEIR ORIENTATION. THE SWITCHES MAY NUMBER FROM LEFT TO RIGHT OR RIGHT TO LEFT. LOOK FOR THE NUMBERING ON THE SWITCHES. MATCH ACCESS CODES A1, A2, -- B1, B2 ETC.

After changing the access code, test the receiver (s) with a matching transmitter. (If the red LED “Wrong Access Code” comes ON in the receiver only while transmitting receiver the code does not match, recheck the access code settings). See receiver manual for LED location.



### WARNING

THE ACCESS CODES IN THE RECEIVER ARE UNIQUE AND FACTORY PRESET. DO NOT CHANGE THESE ACCESS CODES UNLESS YOU ARE REPLACING AN EXISTING RECEIVER AND ITS ACCESS CODE. CHANGING THIS CODE COULD MAKE IT COMMON WITH ANOTHER RECEIVER ACCESS CODE, WHICH COULD MOVE ANOTHER CRANE. NO TWO SYSTEMS IN ANY LOCATION SHOULD EVER HAVE THE SAME ACCESS CODES INDEPENDENT OF FREQUENCY. FAILURE TO FOLLOW THIS WARNING COULD RESULT IN SERIOUS INJURY OR DEATH AND DAMAGE TO EQUIPMENT.

#### 5-2. Multibox.

**Multibox Operation.** (Optional, for receivers with Multibox option only).

**Do not use on IntelSmart Receivers.** Use Group Code feature, see IntelSmart Receiver Manual.



### WARNING

IF YOUR RECEIVER WAS NOT ORDERED WITH MULTIBOX DO NOT ATTEMPT TO PROGRAM MULTIBOX IN THE FIELD. TELEMOTIVE MUST COORDINATE ACCESS CODE ASSIGNMENTS WITH THE TRANSMITTERS PRIOR TO ENABLING MULTIBOX. PLEASE CONTACT TELEMOTIVE IF YOU NEED TO ADD MULTIBOX. FAILURE TO FOLLOW THIS WARNING COULD RESULT IN SERIOUS INJURY OR DEATH AND DAMAGE TO EQUIPMENT.



### WARNING

IF YOUR UNIT HAS MULTIBOX DO NOT ATTEMPT TO PROGRAM ADDITIONAL TRANSMITTERS IN THE FIELD. TELEMOTIVE MUST COORDINATE ACCESS CODE ASSIGNMENTS WITH THE NEW TRANSMITTERS PRIOR TO EXPANDING MULTIBOX. PLEASE CONTACT TELEMOTIVE IF YOU NEED TO ADD ADDITIONAL TRANSMITTERS. FAILURE TO FOLLOW THIS WARNING COULD RESULT IN SERIOUS INJURY OR DEATH AND DAMAGE TO EQUIPMENT.

Many receivers have Multibox capability that allows up to 8 transmitters to access a single system. Only one transmitter may control the receiver(s) at a given time. Access is on a first come first serve basis. Once a transmitter has gained control, another transmitter may not access the receiver(s) until the controlling transmitter relinquishes control by transmitting an OFF command to the receiver(s) or the receiver(s) times out due to inactivity.

The first transmitter to send an ON command after the receiver has been released will then gain control of the receiver(s). The number of transmitters (1-8) allowed to control the receiver(s) is dip switch selectable on the Receiver Board.

#### NOTE

THE DESIRED MULTIBOX TRANSMITTERS MUST HAVE CONSECUTIVE ACCESS CODES BEGINNING FROM THE FIRST ACCESS CODE.

## Section 5 – Programming (Continued)

### 5-3. Programming.

#### 5-3.1. Transmitter Programming Options.

The following parameters are programmable in the transmitter:

- Switch Position – Hoist, Trolley Etc.
- Timer-out-timer operation.
- Modes – Single speed switch grouping.
- Crane configuration -
- Tandem disable – Eliminates “both”
- Select invert – Inverts the select function.

#### 5-3.2. telePendant Programming.

Read Section 4-5. Additional telePendant Operational Features to familiarize you with the features listed below. The telePendant transmitter remote unit for programming uses a PDA (Personal Digital Assistant). Such products as Palm Pilot® or many other products using Palm OS® less than version 5.0 can be used to run the telePendant programming software. If unsure if your PDA will work or for a recommended product contact the appropriate Telemotive representative or check our website. The software for the PDA is available on a disk shipped with your unit, and can be emailed from your Telemotive representative.

telePendant PDA software is quite user friendly and is intended to mimic the dip switch settings used in other Telemotive products without the inconvenience of having to open the transmitter case. The PDA software allows you to select frequency, access code, time-out-timer settings, switch arrangement and crane configuration as in other Telemotive transmitter products. Follow the lettered steps below:

#### A. Load PDA Program.

Load the telePendant programming software into your PDA, refer to your PDA manual or contact Telemotive for the appropriate procedure. Once loaded, look for the Telemotive circle and hook logo labeled Transmitttr for the appropriate application. Select this application to begin programming.



With the telePendant programmer you can load up to four different transmitter types for use on four different systems. Each transmitter configuration is stored in a “Bank”. There are up to four configurable banks

available. This Bank feature is like having four completely different transmitters in one unit. Up to four Banks (operational configurations) are possible. A fifth bank is used for programming. A configurable Bank is a specific configuration of user-defined parameters including:

- Frequency
- Access codes
- Also possible:
  - Key arrangement
  - Relay configuration
  - Tandem disable
  - Invert crane select
  - Time-out-timer time
  - Mode selection
  - Alarm settings

After loading the telePendant program the first screen is the initial setup screen.

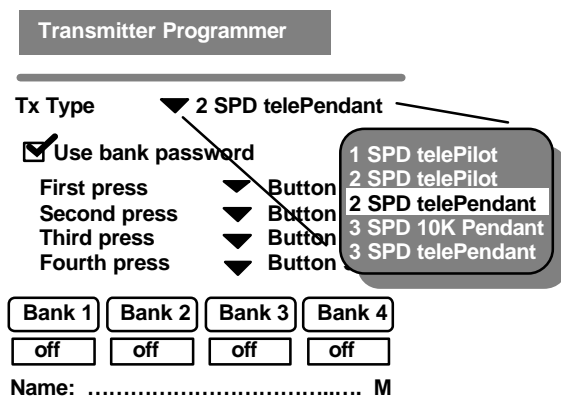

#### B. Enter “Tx Type” (Must be selected).

First select the transmitter type being used (two-speed “2 SPD telePendant” or three-speed “3 SPD telePendant”). With your PDA stylus tap the arrow after transmitter “Tx Type”. A pull down menu will appear, select “2 SPD telePendant” or “3 SPD telePendant” and the menu will close showing your selection.

For 3-Speed legacy 10K receivers select 3-Speed 10K Pendant.

#### C. Enter Bank Password (Can be disabled).

Bank password protection is available in changing the transmitter once it has turned OFF. The Bank Password is the same for all Banks. Bank password protection is described in the telePendant operational description in Section 4-5. Additional telePendant Operational Features. **Please familiarize yourself with this section**

## Section 5 – Programming (Continued)

**before programming.** A check appears in the box and a list of four buttons. These buttons list the first through fourth buttons and are in the order of entry for the appropriate buttons. Select the four transmitter buttons in the sequence that you wish to be the password by tapping the arrow by “Button #” and making a selection from the pull down menu for each of the four password entries. Be sure to write this password down in a safe place for future reference. The default password is 6, 5, 4, 3.

**Transmitter Programmer**

Tx Type    ▼ 2 SPD telePendant

Use bank password

First press    ▼ Button 6

Second press    ▼ Button 5

Third press    ▼ Button 4

Fourth press    ▼ Button 3

Button 1  
 Button 2  
 Button 3  
 Button 4  
 Button 5  
 Button 6

Bank 1	Bank 2	Bank 3	Bank 4
off	off	off	off

Name: ..... M

### NOTE

ALWAYS REMEMBER TO STORE THE PASSWORD IN A SECURE LOCATION FOR ACCESS IF THE PASSWORD IS LOST OR FORGOTTEN. ONCE THE TRANSMITTER IS PROGRAMMED THERE IS NO WAY TO DEFEAT THE PASSWORD WITHOUT USING A PDA TO EITHER READ THE PASSWORD OUT OR REPROGRAM A NEW ONE.



## WARNING

THIS PASSWORD FUNCTION IS NOT TO BE USED AS A SECURITY DEVICE. THE PURPOSE OF THIS FUNCTION IS TO PREVENT ACCIDENTAL BANK SWITCHING. THE BEST FORM OF SECURITY IS ALWAYS TO LOCKUP THE TRANSMITTER WHEN NOT IN SERVICE. FAILURE TO FOLLOW THIS WARNING COULD RESULT IN SERIOUS INJURY OR DEATH AND DAMAGE TO EQUIPMENT.

The Bank password can be disabled during initial programming by the PDA. To disable password protection, tap the check in the box next to the phase “Use bank password”. Disabling the Bank password is not recommended unless the operator has access and visibility to all possible cranes controlled.



## WARNING

DISABLING THE PASSWORD FUNCTION PUTS THE SYSTEM IN ACTIVE BANK SELECT. THIS ALLOWS THE CRANE OPERATOR TO SWITCH BETWEEN BANKS QUICKER. THE OPERATOR IN THIS MODE MUST BE AWARE AND RESPONSIBLE FOR ALL POSSIBLE CONTROLLED CRANES. FAILURE TO FOLLOW THIS WARNING COULD RESULT IN SERIOUS INJURY OR DEATH AND DAMAGE TO EQUIPMENT.

### D. Select a Bank (At least one must be selected).

When done with the password section. Select the number of Bank you wish to program and tap the cell labeled with the appropriate Bank number.

Bank 1	Bank 2	Bank 3	Bank 4
off	off	off	off

The screen should switch to the Setup Bank screen shown below. Complete the Bank setup as described below and hit save. The PDA will revert to the initial screen and the cell for the just programmed Bank should darken and the word “on” appears. Tap on the cell labeled with the next bank you wish to program and a similar “Setup” screen to the one shown below will appear. Continue doing this until you have programmed the four Banks.

You do not have to use all Banks and you do not have to use them in order.

Even after programming a Bank you can turn it back “OFF”. A programmed Bank will not lose its programming by turning it “off”. By turning ON and OFF Banks you can easily save certain transmitter configurations in the transmitter to turn them on at a later time with the PDA without having to completely reprogram them.

## Section 5 – Programming (Continued)

### Setup Bank Programming Screen.

After selecting a Bank, the number of the Bank will appear at the top of the screen.

The respective screens appear as shown below (the 2-Speed screen is shown first):

### 2-Speed telePendant Bank Programming Screen.

“Rx Setting” button on the PDA. The frequency and Access Code will be downloaded, then skip the next two steps.

### F. Select a Frequency (Must be inputted for system to work):

There should be a label either on the receiver or the transmitter being replaced listing frequency, it should be a channel number between AK01 to AK20. Find this number and tap the “Freq” arrow and select that channel number.

### G. Enter the Access Code (Must be inputted for system to work):

#### Screen switch operation.

The screen switches are labeled from left to right “A”, and “B”. They are numbered from left to right 1 to 8. The darken rectangle to the bottom is “OFF” or “0” the darken rectangle to the top is “ON” or a “1”. Tapping the lighten rectangle will cause the switch to toggle.

### telePendant Access Code Programming.

See Section 5.1. Access Code Programming for details on access code programming. There should be a label either on the receiver or the old transmitter showing the access code, it should be numbered A1 through A8 and B1 though B8. Find this number and tap the respective switches on the screen. If you cannot find a label with access code information, copy directly from the access code dip switches in your transmitter or receiver, being careful to match the designation and switch position as they do vary from model to model.

### 3-Speed 10K Pendant and 3-Speed telePendant Bank Programming Screen.

#### NOTE

IF YOU HAVE AN INTELESMART RECEIVER FREQUENCY AND ACCESS CODES CAN EASILY BE DOWN LOADED DIRECTLY INTO YOUR PDA.

### E. Downloading Parameters from an IntelSmart receiver.

Select the Bank you wish to program, cycle the power to the IntelSmart receiver. Within the first 10 seconds of the receiver turning ON, point the PDA at the receiver’s IR port (see receiver manual for location) and tap the

## Section 5 – Programming (Continued)

### H. Multibox (Optional, skip if you do not wish to use the Multibox feature):

Do not use on IntelSmart Receivers. Use **Group Code feature** see IntelSmart Receiver Manual.

See Section 5-2. Multibox for details on Multibox programming. If your current receiver does not have Multibox do not attempt to use this function. This function WILL NOT turn Multibox on in the receiver. It only assists you in programming the correct transmitter access code for a receiver that already has Multibox. Make sure when you are using the Multibox feature that the access code of the receiver is programmed into the access code above and not one copied from an existing transmitter on a Multibox system. If you cannot find the receiver transmitter code and wish to copy existing transmitter on a Multibox system, put the transmitter's access code in the access code switches above and DO NOT check the Multibox box on the PDA.

Select the Tx # this should be the next number in the series of transmitter being put on a Multibox system. If there are two transmitters on already and you are adding a third, select the number 3. Make sure as stated in the Multibox section the receiver is programmed for the appropriate number of transmitters.

The Tx # goes up to 8. Many Multibox systems only go to four. Check with your Telemotive representative if you need more than 4 transmitters on a Multibox system.

The time it takes the transmitter to shutoff due to un-use is programmable. Tap the arrow next to the word "Timer" to program and scroll through the numbers shown. Units shown are in minutes.

### J. Active ESTOP.

This feature causes the Receiver to shutdown if the transmitter is out of range. For this to work the companion receiver must have this feature also. Please check the receiver manual. All IntelSmart receivers have this feature, both the receiver and the transmitter must have this box checked. DO NOT use this feature with non equipped receivers. It is not recommended to have multiple transmitters on the same channel if Active ESTOP is used due to the additional channel loading.

### K. Auto Turn Off. (Normally Leave Checked).

Auto Turn Off causes the unit to send an OFF command to the receiver if the battery goes bad or the transmitter times out. Removing the check from this box disables this feature.

### L. Go to the appropriate Section for your system.

5-3.3 2-Speed *telePendant*, Page 24.

5-3.4 3-Speed *telePendant*, Page 26.

5-3.5 3-Speed 10K Pendant, Page 27.

Setup Bank #

System ▼ 10K      Freq ▼ AK01

A1 [0][1][2][3][4][5][6][7][8][9] 1  
[0]      B1 [0][1][2][3][4][5][6][7][8][9] 1  
0      0

Receiver access code      RX Setting

Multibox       Active ESTOP

Auto Turn Off      Tx # ▼ 1

S3-1 [0][1][2][3][4][5][6][7][8][9] 1  
[0]      Timer ▼ 15

Switch conf.: H,T,B

Main/Aux ▼ Aux only      Save

Cancel

Multibox Programming

### *telePendant* Multibox Programming.

### I. Set Time-Out–Timer Time. Default time is 15 minutes.

Timer ▼ 15

## Section 5 – Programming (Continued)

### 5-3.3. 2-Speed telePendant Programming.

#### NOTE

IF REPLACING A MEMBRANE OR PENDANT TRANSMITTER, YOU CAN COPY THE SWITCH SETTINGS ON THE EXISTING TRANSMITTER.

**Membrane:** Copy Switch 3 (all positions) settings on the Membrane transmitter to S3 on the PDA.

**Pendant:** Copy Switch 3 (positions 1, 2, 3 and 8) settings on the Pendant transmitter to S3 (positions 1, 2, 3 and 8 respectively) on the PDA. Copy Switch 4 (positions 5, 6 and 7) settings on the Pendant transmitter to S3 (positions 5, 6 and 7 respectively) on the PDA. If Switch 4 on the Pendant transmitter has positions 1 and or 2 Switched ON see the write-up on Main/Aux Menu below. If SW4 position 3 is switched “ON” un-check Tandem box on PDA. If SW4 position 4 is switched “ON” check Invert box on PDA.

**M. S3 Programming. Not required for an IntelSmart receiver.**

**S3 Positions 1-3 Repositioning of telePendant Transmitter Motion Switch Functions. (Standard configuration all “OFF”).**

S3 positions 1 through 3 can change the functional positions of the switches controlling hoist, trolley and bridge. This reconfiguration does NOT affect receiver wiring. As these switches are changed the motor controls are moved.

Standard, Motor 1 is H (Hoist) Motor 2 is T (Trolley) and Motor 3 is B (Bridge). The standard configuration (all switches OFF) is, starting at the top right hand pair of buttons on the transmitter, Motor 1. Moving down to the middle two right hand pair of buttons that is Motor 2. The bottom pair on the right is Motor 3. This is indicated the display “Switch config: H,T,B. The order of Hoist, Trolley and Bridge will vary as S3-1 to 3 switch positions is changed. Toggle the switches sequentially till you see the order you need. There are six possible combinations.

**S3 Position 4 And 8 Time-out-timer Disable. (Normally turned “OFF”).**

Disables the transmitter time-out-timer if turned ON. If the time-out-timer is active, the length of time for time out can be selected for numbers of minutes till shut down. The minutes are selectable in one-minute steps from 1 to 10 and five minutes steps up to an hour. Tap

on the “Timer” arrow and scroll down through the number of minutes and tap on the desired number.

**Positions 5-7 Special Crane Control Configurations. (Standard all “OFF”).**

The wiring section of the manual for receiver shows all the different crane configurations and the switch positioning needed to achieve them. The standard transmitter comes with the output standard output configuration. For special crane control configurations program S3 positions 5-7 to match the programming information shown for the respective wiring diagram. When any of the special crane configuration switches is turned ON, the words “Crane control enabled” appears on the display and Main/Aux disappears.

**Position 8, Same as Switch Position 4. See write up for switch 4 above (Normally turned “OFF”).**

**N. Main/Aux Menu for controlling the “Programmable Motor Control and Select Push Button”.**

**This menu shows only if no Special Crane Configurations are selected (Switch 3 positions 5-7).** This programming redefines the function of the button just above the E-STOP.

**(If a three motor crane use “Aux”, for standard four motor use “Motor”, for Select function use Select).**

If replacing a Pendant transmitter: if Switch 4 on the Pendant transmitter has position 1 “OFF” and position 2 “ON” use “Motor”, if Switch 4 has position 1 “ON” and position 2 “ON” use “Select”.

For a **three motor** system this Programmable Motor Control and Select push button is non functional.

For a **four motor system** this button controls a main and aux motor such as a hoist. (See Section 4. Operation, for details on the operation of this button.) To program a fourth motion select “Motor”. This four motor application can only be used with 4 motor crane configurations. The Programmable Motor Control and Select push button becomes a switch to toggle between “A” and “B” or both. Where “A” and “B” are main and auxiliary motors respectively. The main motor output is motor 1 and the auxiliary motor output is motor 4.

For up to **5 motors** using the **select function** this button is available to use select relays. This select function can only be used with five crane configurations. To program in the select function tap the word “Select”. The Programmable Motor Control and Select push button



## Section 5 – Programming (Continued)

becomes a switch to toggle between “A” and “B” or both. Where “A” and “B” are Select 2 and Select 1 outputs respectively.

### NOTE

THE “A” LED LIT CAUSES THE SELECT 2 RELAY TO CLOSE. THE “B” LED CAUSES THE SELECT 1 RELAY TO CLOSE.

#### Tandem For Hoist, Trolley or Bridge. (Normally checked).

This function appears if a four motor system or select function is chosen. Normally the box is checked meaning “Both A and B” operation is enabled (both MAIN and Aux or Select 2 and Select 1 can be ON at the same time). Removing the check from the box by tapping on it disables the “Both” function. (“A” and “B” will not come ON at the same time). This function maps to Pendant Switch 4 position 3, if SW4 position 3 is switched “ON” un-check Tandem box on PDA.

#### Position 4 Invert Crane Select Aux. Outputs. (Normally not checked).

This function appears if a system using select is programmed in. Turning this switch “ON” inverts the select function operation so that the relay closes for the unselected function. This function maps to Pendant Switch 4 position 4, if SW4 position 4 is switched “ON” check Invert box on PDA.

#### 5-4. Saving, Downloading, Reading the Programs and Other PDA Functions on page 28.

### NOTE

**TO PROGRAM OR READ DATA FROM THE *tele*Pendant, THE TRANSMITTER MUST BE TURNED ON AND IN BANK FIVE (5).**

**Setup Bank #**

System ▼ 10K      Freq ▼ AK01

A1 [0][0][0][0][0][0][0][0][0][0] 1  
 B1 [0][0][0][0][0][0][0][0][0][0] 1

Receiver access code      **RX Setting**

Multibox       Active ESTOP

Auto Turn Off

S3-1 [0][0][0][0][0][0][0][0][0][0] 1      Timer ▼ 15

Switch conf.: H,T,B

Main/Aux ▼ Aux only      **Save**

**Cancel**

Tandem     Invert    Crane control enabled

**This completes the 10K 2-speed programming, when completed with the above tap “Save”.**

Save will take you back to the Initial start screen. At this point select another Bank to program or **Go to Section**

## Section 5 – Programming (Continued)

### 5-3.4. 3-Speed telePendant Programming .

#### M. Motor Menu for controlling the “Programmable Motor Control” Push Button.

(If a three motor crane use “3”, for standard five or four motor use “5”).

For **three motor system** this push button is non functional. (Motor “3”). This configuration is typically used with the IntelSmart 16 output Receiver.

For **five motor system** this button controls main and aux motors such as a hoist and trolley. (See Section 4. Operation, for details on the operation of this button). To program a fourth or fifth motion select (Motor “5”). This five motor application can only be used with the IntelSmart 24 output Receiver. The Programmable Motor Control push button becomes a switch to toggle between “A” and “B” or both. Where “A” and “B” are main and auxiliary motors respectively. The main motor outputs are motor 1 and motor 2 and the auxiliary motor outputs are motor 4 and 5 respectively.

#### Tandem for Hoist, Trolley or Bridge. (Normally not checked).

This function appears if a four or five motor system function is chosen. Normally the box is not checked meaning “Both A and B” operation is enabled (both MAIN and Aux can be ON at the same time). Removing the check from the box by tapping on it disables the “Both” function. (“A” and “B” will not come ON at the same time). This function maps to Pendant Switch 4 position 3, if SW4 position 3 is switched “ON” check Tandem box on PDA.

**This completes the telePendant 3-Speed programming, when completed with the above tap “Save”.**

Save will take you back to the initial start screen. At this point select another Bank to program or **Go to Section 5-4. Saving, Downloading, Reading the Programs and Other PDA Functions on page 28.**

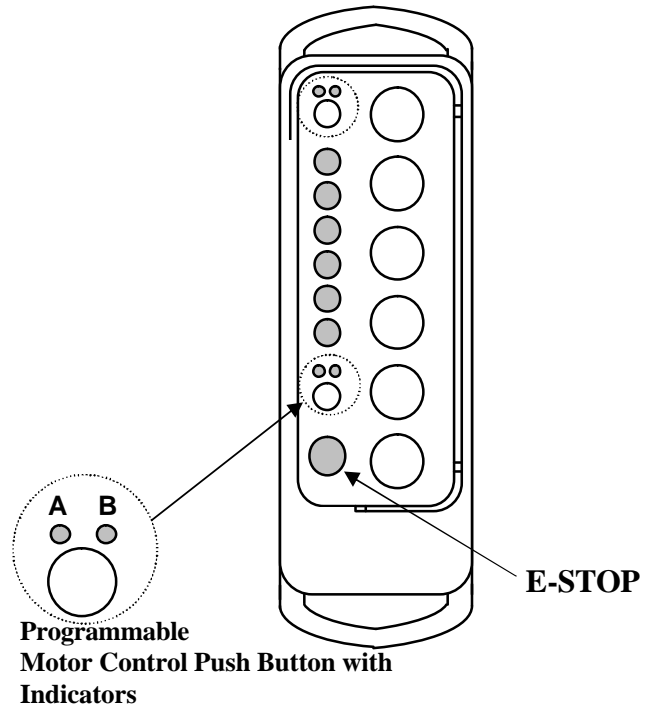

**3 speed telePendant Transmitter.**

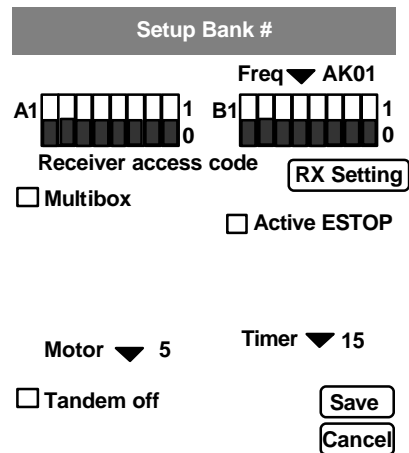

#### NOTE

**TO PROGRAM OR READ DATA FROM THE telePendant, THE TRANSMITTER MUST BE TURNED ON AND IN BANK FIVE (5).**

## Section 5 – Programming (Continued)

### 5-3.5. 3-Speed 10K Pendant Programming.

#### N. Motor Menu for controlling the “Programmable Motor Control and Select” Push Button.

(If a three motor crane use “3”, for standard five motor use “5”, for Select function use Select).

For **three motor system** this push button is non functional. (Motor “3”). This configuration is typically used with the 10K16 output Receiver.

For **five motor systems** this button controls the main and aux motors such as a hoist and trolley. (See Section 4. Operation for details on the operation of this button). To program a fifth motion select (Motor “5”). This five motor application can only be used with the 10K24 output Receiver. The Programmable Motor Control and Select push button becomes a switch to toggle between “A” and “B” or both. Where “A” and “B” are main and auxiliary motors respectively. The main motor outputs are motor 1 and motor 2 and the auxiliary motor outputs are motor 4 and 5 respectively.

For up to **5 motors** using the **select function** this button is available to use select relays (Motor “Select”).

#### Aux Trolley OFF

This function appears if a 5 motor system is programmed in. Checking the box disables the Aux Trolley function for a 4 motor system.

#### Tandem OFF For Hoist, Trolley or Bridge. (Normally not checked).

This function appears if a five motor system or select function is chosen. Normally the box is not checked meaning “Both A and B” operation is enabled (both MAIN and Aux or Select 2 and Select 1 can be ON at the same time). Putting the check in the box by tapping on it disables the “Both” function. (“A” and “B” will not come ON at the same time). This function maps to Pendant Switch 4 position 3, if SW4 position 3 is switched “ON” check Tandem OFF box on PDA.

**This completes the telePendant 3-Speed programming, when completed with the above tap “Save”.**

Save will take you back to the Initial start screen. At this point select another Bank to program or **Go to Section 5-4. Saving, Downloading, Reading the Programs and Other PDA Functions on page 28.**

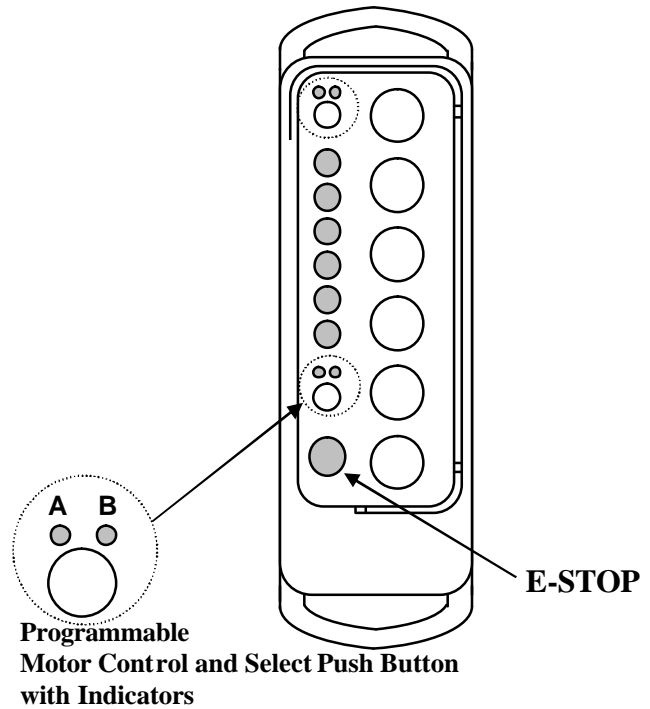

**3 Speed 10K Pendant Transmitter.**

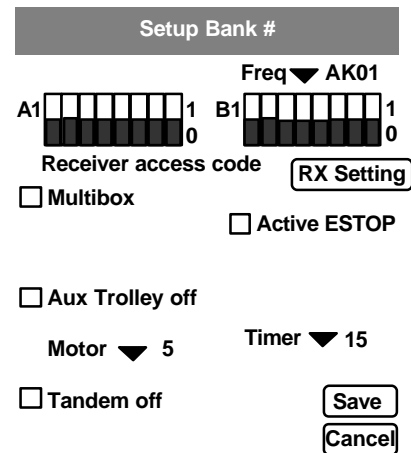

#### NOTE

**TO PROGRAM OR READ DATA FROM THE telePendant, THE TRANSMITTER MUST BE TURNED ON AND IN BANK FIVE (5).**

## Section 5 – Programming (Continued)

### 5-4. Saving, Downloading, Reading The Programs and Other PDA Functions.

#### NOTE

**TO PROGRAM OR READ DATA FROM THE *telePendant*, THE TRANSMITTER MUST BE TURNED ON AND IN BANK FIVE (5).**

#### Saving the Programming File.

With the initial *telePendant* screen displayed, tap in the lower left corner of your PDA, the title bar at the top of the screen will show a menu or tap on the word “*telePendant*”. Choose the way you wish to save the file. Tap on your choice and follow the instructions on the PDA to complete file saving. Old files can be deleted, called up, modified and renamed by this same menu.

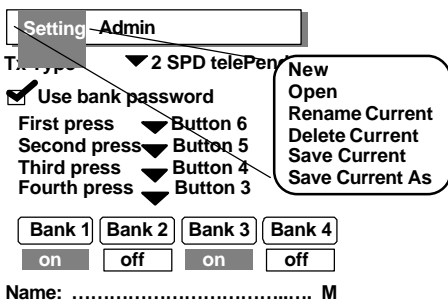

#### Sending a Program to the *telePendant*.



## WARNING

AFTER EVERY PROGRAMMING OF THE TRANSMITTER, TEST THE UNIT BY TURNING IT ON AND OFF NEAR THE APPROPRIATE RECEIVER. IF THE RECEIVER DOES NOT RESPOND, DO NOT ACTIVATE A FUNCTION BUTTON! THE TRANSMITTER MAY HAVE INCORRECT PROGRAMMING, WHICH COULD MOVE ANOTHER CRANE. RE-CHECK THE PROGRAMMING IN THE TRANSMITTER AND RETEST. AFTER ACTIVATION OF RECEIVER, FUNCTIONALLY TEST ALL COMMANDS ON THE TRANSMITTER BY INITIALLY JOGGING THE BUTTONS, THEN WITH A FULL MOVEMENT BEFORE RETUNING TO SERVICE. FAILURE TO FOLLOW THIS WARNING COULD RESULT IN SERIOUS INJURY OR DEATH AND DAMAGE TO EQUIPMENT.

To send a program file, consisting of up to four banks, to a *telePendant* Transmitter:

1. Turn transmitter unit OFF. Note that the Tx Red LED is OFF.
2. Switch the unit to Bank 5 by: pressing the ON button down, while holding the ON button down then press the fifth down from the top motion button down, then release the ON button and then release the fifth motion button.. Note that the Tx Red LED is flashing quickly fives times then pausing. This flashing indicates you are in bank 5.
3. Line up the PDA’s infrared port with the transmitters infrared port (remove battery door on the back and pull battery pack back and expose the *telePendant*’s infrared port. See figure below: *telePendant* Infrared Port Access).

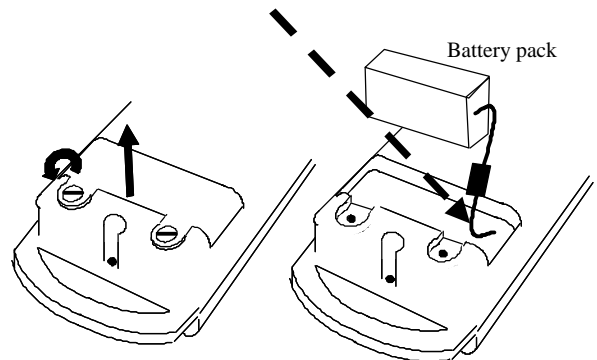

#### *telePendant* Infrared Port Access.

4. From the application file’s main menu click on the PDA a dropdown menu icon located at bottom left corner or tap on the word “Programmer” at the top of the screen. Select “Admin.”
5. Under “Admin.” select “Send Setting.”

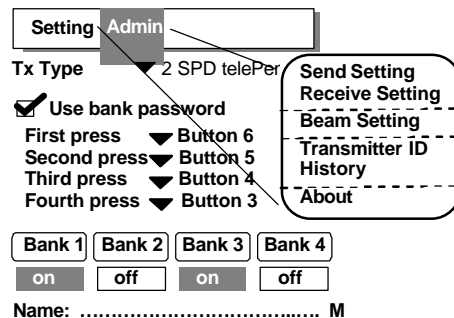

## ***Section 5 – Programming (Continued)***

6. Select a name you want for the *telePendant* unit being programmed and tap “OK”.
7. Wait for confirmation text on PDA screen:
8. After programming, always operationally test all the functions of the transmitter by using the appropriate receiver with the MR relay disabled before retuning transmitter to service.

### **Receiving (Reading) the *telePendant* Programming.**

To read a program file from the *telePendant* Transmitter:

1. Line up the PDA’s infrared port and go to bank 5 as in steps 1 to 3 above, with the transmitter ON. Select “Admin”
2. Select “Receive Setting.”
3. PDA will confirm reception and automatically display current programming in the *telePendant* unit.

### **Reading the *telePendant* ID.**

To read an identity (an identity is the name that was programmed in by step 5 of Sending a Program To The *telePendant*, listed above) from the *telePendant* Transmitter:

1. Line up the PDA’s infrared port and go to bank 5 as in steps 1 to 3 above, with the transmitter ON. Select “Admin”
2. Select “Transmitter ID.”
3. PDA will read: Name, Serial/Job Number, and Manufacturing information of the *telePendant* unit.

### **Reading the *telePendant* History.**

To read Service information from the *telePendant* Transmitter:

1. Line up the PDA’s infrared port and go to bank 5 as in steps 1 to 3 above, with the transmitter ON. Select “Admin”
2. Select “History”
4. Unit will read: Past Service Orders of the *telePendant* unit.

### **Reading the PDA Transmitter Software Version.**

To read PDA Software Version from the *telePendant* Transmitter:

1. Select “Admin”
2. Select “About”
3. Unit will read: Transmitter Programmer Software Version number.

### **Beaming (Sending) the Configuration(s) to another PDA.**

To send a configuration setting to another PDA.

1. Line up the PDA’s infrared port as, with the other PDA, which is turned ON.
2. Select “Beam Setting.”
3. Select the item(s) you wish to send.
4. Wait for confirmation text on PDA screen:

### **Error Statements and Codes.**

Tx Type Mismatch; If while attempting to program a *telePendant* you receive an error code such as “Error AAAB” you have selected a different style transmitter in the PDA than you are attempting to program. Most common cause is trying to program a 2-speed *telePendant* with 3-speed selected or visa versa.

### **NOTE**

**TO PROGRAM OR READ DATA FROM THE *telePendant*, THE TRANSMITTER MUST BE TURNED ON AND IN BANK FIVE (5).**

## **Section 6 – Spare Parts**

### **telePendant TRANSMITTER**

<b>PART NUMBER</b>	<b>DESCRIPTION</b>
Call	MAIN CIRCUIT BOARD 2- or 3-SPEED (Please contact Telemotive with Job Number to assure exact replacement).
H1212-0	#4 x 3/8" SELF TAPPING SCREWS, PC BOARD MOUNTING (2)
H1147-0	NEOPRENE WASHER, PC BOARD MOUNTING (4)
H1976-0	STEEL FLAT WASHER, PC BOARD MOUNTING (2)
N10705-1	LABELS (AUXILIARY FUNCTION)
MP10620-0	SHOULDER STRAP
TCTX12P-0	MANUAL
FW3045-1	PDA PROGRAMMING SOFTWARE
MP10709-0	BELT LOOP ASSEMBLY
A10737-0	BATTERY DOOR ASSEMBLY
S1088-102	PUSH BUTTON SWITCH 2-SPEED ASSEMBLY (3)
S1088-103	PUSH BUTTON SWITCH 3-SPEED ASSEMBLY (3)
H1151-0	PUSH BUTTON SWITCH SCREWS (6)
S1085-0	MEMBRANE SWITCH PACK
WA1055-0	SWITCH RIBBON CABLE
A10743-0	TOP HOUSING ASSEMBLY
MP10734-0	TOP HOUSING ONLY
MP10735-0	BOTTOM HOUSING
H1240-0	HOUSING SCREWS (8)
MP10742-0	BOOTS/RING/LENS ASSEMBLY
MP10705-2	BATTERY, "AA" HOLDER ASSEMBLY
BT111-0	BATTERY, LITHIUM DISPOSABLE
BT111-1	BATTERY, RECHARGEABLE LITHIUM ION
A10723-0	BATTERY CHARGER, RECHARGEABLE LITHIUM ION FOR BT111-1

