



# ***SMARTAMP*** <sup>TM</sup>

## **BI-DIRECTIONAL POWER AMPLIFIER** **2.4 GHz, 1W version**

### ***User and Installation Manual***

**TELETRONICS INTERNATIONAL, INC.**  
**1803 Research Blvd., Suite 404,**  
**Rockville, Maryland, USA, 20850-3155**

**Email:** [sales@teletronics.com](mailto:sales@teletronics.com)

**Web Site:** [www.teletronics.com](http://www.teletronics.com)

**Tel:** (301)-309-8500

**Fax:** (301)-309-8851

**Copyright ©2002**  
**by**  
**Teletronics International, Inc.**  
**Patent Pending**

---

All Rights Reserved. No part or parts of this document may be reproduced, translated, stored in any electronic retrieval system, or transmitted, in any form or by any means, electronic, mechanical, photocopying, recording, or otherwise, without the prior written permission of the copyright holder.

---

## Table of contents

User and Installation Manual	i
<b>1. General Product Description</b>	<b>3</b>
<b>2. Background</b>	<b>3</b>
<b>3. Major Parameters</b>	<b>4</b>
<b>4. Salient Characteristics:</b>	<b>5</b>
<b>5. Installation:</b>	<b>6</b>
<b>6. DC Power Injector Connections, Indicators and labels:</b>	<b>6</b>
<b>7. Amplifier Connections, Indicators and Labels:</b>	<b>7</b>
<b>8. Functioning:</b>	<b>7</b>
<b>9. Specifications:</b>	<b>8</b>
General Specifications	8
Nominal Loss Characteristics For Different Cables	9
<b>10. LIMITED WARRANTY</b>	<b>10</b>

## 1. General Product Description

SMART Amplifier (SMARTAMP) is a new bi-directional antenna-mount amplifier designed to match any advanced spread spectrum system, either direct sequence or frequency hopping, to allow the extension of the operating range in wireless environment. It is provided in a wide range of frequencies, such as 900 MHz, 2400 MHz, or 5800 MHz where advanced spread spectrum systems are operated. It works in Time-Division Duplex (TDD) mode that allows the radio device sharing the antenna in different time intervals. SMARTAMP consists of an intelligent algorithm and Automatic Gain Controlled (AGC) circuits to maintain the output power and prevent transmit signal saturation. The input transmit power level is sensed by the Radio Frequency (RF) sensor and the gain is automatically adjusted to minimize the signal distortion so that the desired signal quality can be assured.

This product has a wide range of wireless applications in Wireless Local Area Network (WLAN), Wireless Local Loop (WLL), Wireless Internet Access (WIA), wireless modem connection with point-to-point, point-to-multipoint, where the Time Division Duplex (TDD) technology is used.

## 2. Background

In wireless applications, when longer operating range is required, the add-on antenna amplifier and DC injector set are often a choice. Because of different site layout and hardware configuration, it is almost impossible for amplifier manufacture to design the amplifier and fit all applications. Typically, in most applications, the interconnection cable could have different length from a few feet to a few hundred feet. The attenuation between DC injector and bi-directional amplifier could be few dB to more than 20 dB. Also, different radio modems have different output powers. Thus, the system installer must carefully measure the input RF power at the antenna amplifier and specify the gain of the amplifier in order to maintain the system performance. With different systems, different amplifiers are required. With this invention, the major difference as compared to other existing technology, is the "SMART function" - power level detection and automatic gain control circuit. With SmartAmp, the gain can be intelligently adapt to the input power level in a wide range and automatically further adjusted to accommodate the cable and connectors loss, by however length and configuration. The output power level is monitored and maintained intelligently, hence the desired performance can be achieved in all hardware configurations for TDD wireless applications irrespective of installation environment.

The table below summarizes the difference between SMARTAMP and other TDD antenna-mount amplifier product.

### Differences Between SmartAmp and Other TDD Amplifier

	<b>SMARTAMP</b>	<b>Other TDD Amplifier</b>
Transmit gain	Intelligent self adjusted	Fixed
Transmit power level	Maintained	Varies, depending on input power level
Transmit signal distortion	Minimized at all time	Much worse at high input power levels
Input power range requirements	Wide range accepted	Designed for narrow range only

### 3. Major Parameters

Smart Amplifier fitted with a Low Noise amplifier (LNA) and together with its unique bi-directional features is fully capable of enhancing the coverage area of 2.4 GHz radio signals by amplifying transmitted and received signals.

The Smart Amp ensures a seamless RF link in most installations with long cable losses. Its unique outdoor design enables it to be mast mounted and to operate in wide temperature range of -40 to +75 C.

2.0 mW (+3 dBm) input to the amplifier delivers 1Watt output. For signal input values greater than 3 dBm the Smart Amplifier attenuates the signal accordingly and keeps the output at 30 dBm. Up to 200 mW of power may be safely applied directly to the amplifier input without causing any damage.

#### The complete set includes:

1. An outdoor unit, the SmartAmp
2. DC injector
3. Universal power supply
4. Mounting hardware.

The DC injector carries the power along with RF signal to the outdoor unit via coaxial cable.

#### 4. Salient Characteristics:

- Complete One Year Warranty on parts and labor.
- Automatic gain control to minimize the signal distortion
- Wide Transmit input levels (2mW to 200mW)
- Low noise amplifier with system noise figure 3.5dB
- Universal 110/220VAC auto switching AC adapter for DC power injector
- Green LED on DC Injector for power.
- Bi-color LED on SmartAmp for transmit and receive.
- SmartAmp equipped with Lightning Protection if grounded properly.
- DC injector equipped with surge protection.
- Industry standard “N” Connectors on both ends.
- Outdoor Weatherproof enclosure.



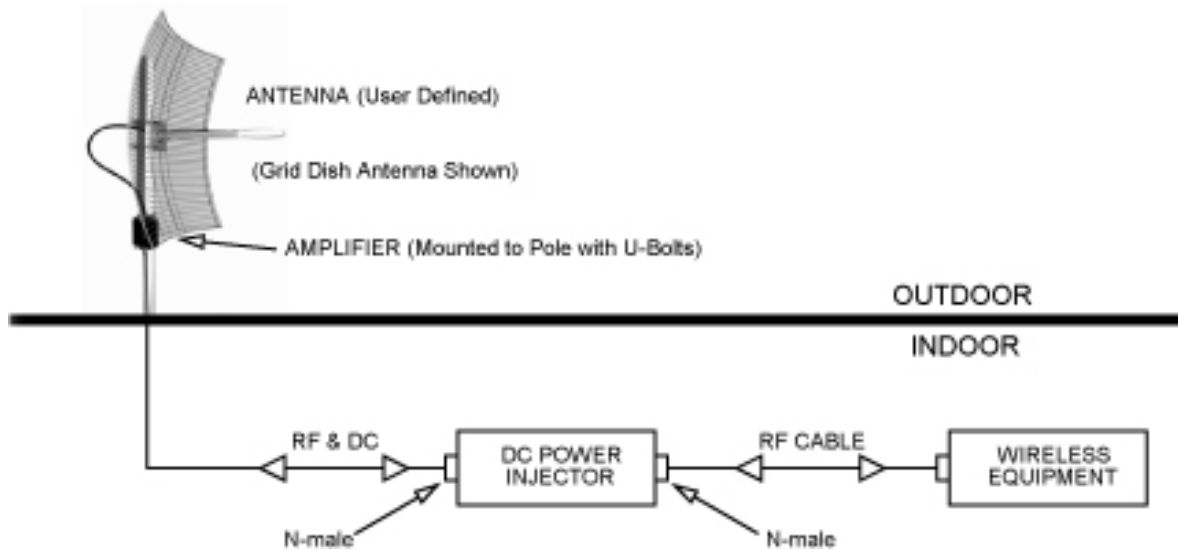

## 5. Installation:

The SmartAmp is a stand-alone unit designed for installation by professional radio installers.

### Typical Installation:

As shown in the above diagram power is carried to the amplifier from DC Injector via RF cable. The DC injector is an indoor unit and requires weather protection. The amplifier is installed at the antenna pole (or mast) with the U-bolt assembly. It is a weatherproof unit and designed to withstand the outdoor environment. Since the SmartAmp is built with lightning protection circuitry, it is extremely important to ground the whole unit. A grounding cable can be tightened directly to the U bolt. This would not only ground any lightning strike on the antenna but would also relieve it from any static buildup in the environment during bad weather.

Once the unit is installed and tested, all the N connectors must be waterproofed with electric tape or any other sealant.

### Caution:

- I. **The RF cable between the DC Injector and the amplifier carries 12V DC power, make sure it is NOT shorted to ground, OR DC Injector could be permanently damaged.**
- II. **If this cable is accidentally connected to “To Antenna” connector on the Amplifier (since it has lightning protection with DC ground), the DC Injector could be permanently damaged.**

## 6. DC Power Injector Connections, Indicators and labels:

The DC injector injects DC power into the RF cable and the power is carried to the amplifier with the RF signal.

### “To Radio” Connection:

This “N” Female connector is connected to the radio modem via a short jumper RF cable.

**“To Amplifier” Connection:**

This “N” Female connector connects to the amplifier on the mast via the transmission cable.

**LED:** Green LED indicates DC power on.

**DC Power Supply:**

The power supply provided with the unit is universal type, 110/220 V AC to 12 VDC converter. This has been tested for quality and performance. If a different 12V DC adapter has to be used make sure it is provided with center positive 2.5mm jack and minimum of 1.2 Amp rated capacity.

**7. Amplifier Connections, Indicators and Labels:****“TO DC Injector” Connection:**

This “N” Female connector is connected to the DC Power Injector via the transmission cable.

**“TO Antenna” Connection:**

This “N” Female connector connects to the antenna with a short length of coax cable.

**LED:**

This LED indicates three states:

1. Transmit = Green
2. Receive = Red
3. High speed Tx / Rx switching = Orange

**8. Functioning:**

The unit operates automatically and no user adjustments are required.

This amplifier is designed for 2.4 GHz radios using Time Division Duplex (TDD) mode of operation. It is equipped with a high speed Tx / Rx switch, that detects transmit signal and switches to transmit mode within 600 ns. In the absence of any transmit signal the unit stays in receive mode. If used with a radio devices using separate bands for transmit and receive in a true full duplex mode, the amplifier would not work.

**9. Summary:**



This manual describes how SmartAmp as a product exploits the automatic gain control by detecting the input power level, automatically adjusting its gain and maintaining the output power to a specified level while minimizing the signal distortion and maximizing and transmission distance. This product has a wide range of wireless applications in Wireless Local Area Network (WLAN), Wireless Local Loop (WLL), Wireless Internet Access (WIA), wireless modem connection with point-to-point, point-to-multipoint, where the Time Division Duplex (TDD) technology is used.

Should you have any problems using it, call our service department at 301-309-8500.

## 9. Specifications:

### *General Specifications*

Operating Range	2400 ~ 2500 MHz
Operating Mode	Bi-directional TDD
Transmit Output Power	+30 dBm ( 1Watt )
Transmit Input Power	9 dB min, 23 dB max
Transmit Gain	Automatically adjusts up to 27dB
Receive Gain	17 dB
Frequency Flatness	±1.0 dB
Noise Figure	3.5 dB
Lightening Protection	Direct DC ground at antenna port
DC Surge Protection	At 12 V DC input
LED indicators on Amp	Tx: Green, Rx: Red
Operating Temperature	-40 °C ~ + 75 °C
Power Supply	12 V DC at 1.1 Amp
RF Connector	Type N, Female

**CAUTION:** Do not exceed 200mW (+23 dBm) of input power to the amplifier.

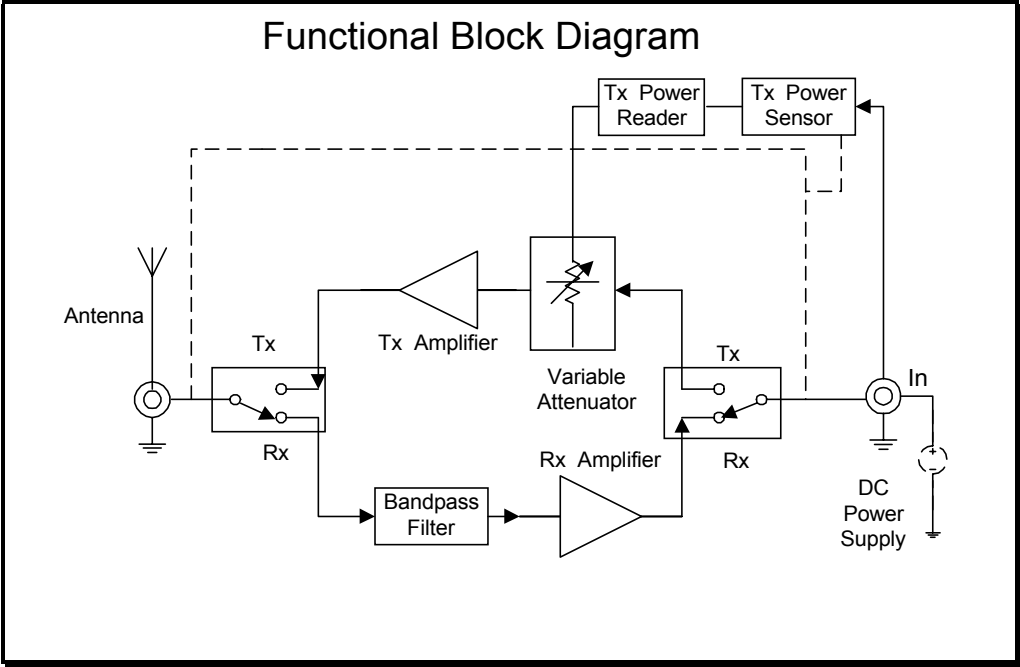

**Nominal Loss Characteristics For Different Cables**  
(decibels per hundred feet at 2.5 GHz)

LMR-400	6.8 dB
LMR-500	5.5 dB
LMR-600	4.4 dB
LMR-900	3.0 dB
LMR-1200	2.27 dB

## **10. LIMITED WARRANTY**

The SmartAmp is warranted to the original purchaser to be free from defects in materials and workmanship under normal installation, use, and service for a period of one (1) year from the date of purchase.

Under this warranty, Teletronics International, Inc. shall repair or replace (at its option), during the warranty period, any part that proves to be defective in material of workmanship under normal installation, use and service, provided the product is returned to Teletronics International, Inc., or to one of its distributors with transportation charges prepaid. Returned products must include a copy of the purchase receipt. In the absence of a purchase receipt, the warranty period shall be one (1) year from the date of manufacture.

This warranty shall be voided if the product is damaged as a result of defacement, misuse, abuse, neglect, accident, destruction or alteration of the serial number, improper electrical voltages or currents, repair, alteration or maintenance by any person or party other than a Teletronics International, Inc. employee or authorized service facility, or any use in violation of instructions furnished by Teletronics International, Inc.

This warranty is also rendered invalid if this product is removed from the country in which it was purchased, if it is used in a country in which it is not registered for use, or if it is used in a country for which it was not designed. Due to variations in communications laws, this product may be illegal for use in some countries. Teletronics International, Inc. assumes no responsibility for damages or penalties incurred resulting from the use of this product in a manner or location other than that for which it is intended.

**IN NO EVENT SHALL TELETRONICS INTERNATIONAL, INC. BE LIABLE FOR ANY SPECIAL, INCIDENTAL OR CONSEQUENTIAL DAMAGES FOR BREACH OF THIS OR ANY OTHER WARRANTY, EXPRESSED OR IMPLIED, WHATSOEVER.**

Some states do not allow the exclusion or limitation of special, incidental or consequential damages, so the above exclusion or limitation may not apply to you.

This warranty gives you specific legal rights, and you may also have other rights that vary from state to state.