

# GL865-DUAL/QUAD V3 Hardware User Guide

1vv0301018 Rev.7 - 2013-10-30



## APPLICABILITY TABLE

PRODUCT
GL865-DUAL V3
GL865-QUAD V3



*SPECIFICATIONS SUBJECT TO CHANGE WITHOUT NOTICE*

**Notice**

While reasonable efforts have been made to assure the accuracy of this document, Telit assumes no liability resulting from any inaccuracies or omissions in this document, or from use of the information obtained herein. The information in this document has been carefully checked and is believed to be entirely reliable. However, no responsibility is assumed for inaccuracies or omissions. Telit reserves the right to make changes to any products described herein and reserves the right to revise this document and to make changes from time to time in content hereof with no obligation to notify any person of revisions or changes. Telit does not assume any liability arising out of the application or use of any product, software, or circuit described herein; neither does it convey license under its patent rights or the rights of others.

It is possible that this publication may contain references to, or information about Telit products (machines and programs), programming, or services that are not announced in your country. Such references or information must not be construed to mean that Telit intends to announce such Telit products, programming, or services in your country.

**Copyrights**

This instruction manual and the Telit products described in this instruction manual may be, include or describe copyrighted Telit material, such as computer programs stored in semiconductor memories or other media. Laws in the Italy and other countries preserve for Telit and its licensors certain exclusive rights for copyrighted material, including the exclusive right to copy, reproduce in any form, distribute and make derivative works of the copyrighted material. Accordingly, any copyrighted material of Telit and its licensors contained herein or in the Telit products described in this instruction manual may not be copied, reproduced, distributed, merged or modified in any manner without the express written permission of Telit. Furthermore, the purchase of Telit products shall not be deemed to grant either directly or by implication, estoppel, or otherwise, any license under the copyrights, patents or patent applications of Telit, as arises by operation of law in the sale of a product.

**Computer Software Copyrights**

The Telit and 3rd Party supplied Software (SW) products described in this instruction manual may include copyrighted Telit and other 3rd Party supplied computer programs stored in semiconductor memories or other media. Laws in the Italy and other countries preserve for Telit and other 3rd Party supplied SW certain exclusive rights for copyrighted computer programs, including the exclusive right to copy or reproduce in any form the copyrighted computer program. Accordingly, any copyrighted Telit or other 3rd Party supplied SW computer programs contained in the Telit products described in this instruction manual may not be copied (reverse engineered) or reproduced in any manner without the express written permission of Telit or the 3rd Party SW supplier. Furthermore, the purchase of Telit products shall not be deemed to grant either directly or by implication, estoppel, or otherwise, any license under the copyrights, patents or patent applications of Telit or other 3rd Party supplied SW, except for the normal non-exclusive, royalty free license to use that arises by operation of law in the sale of a product.



## Usage and Disclosure Restrictions

### License Agreements

The software described in this document is the property of Telit and its licensors. It is furnished by express license agreement only and may be used only in accordance with the terms of such an agreement.

### Copyrighted Materials

Software and documentation are copyrighted materials. Making unauthorized copies is prohibited by law. No part of the software or documentation may be reproduced, transmitted, transcribed, stored in a retrieval system, or translated into any language or computer language, in any form or by any means, without prior written permission of Telit

### High Risk Materials

Components, units, or third-party products used in the product described herein are NOT fault-tolerant and are NOT designed, manufactured, or intended for use as on-line control equipment in the following hazardous environments requiring fail-safe controls: the operation of Nuclear Facilities, Aircraft Navigation or Aircraft Communication Systems, Air Traffic Control, Life Support, or Weapons Systems (High Risk Activities"). Telit and its supplier(s) specifically disclaim any expressed or implied warranty of fitness for such High Risk Activities.

### Trademarks

TELIT and the Stylized T Logo are registered in Trademark Office. All other product or service names are the property of their respective owners.

Copyright © Telit Communications S.p.A.



## Contents

<b>1. Introduction</b>	<b>8</b>
1.1. Scope	8
1.2. Audience	8
1.3. Contact Information, Support	8
1.4. Document Organization	9
1.5. Text Conventions	10
1.6. Related Documents	10
<b>2. Overview</b>	<b>11</b>
<b>3. GL865-DUAL/QUAD V3 Mechanical Dimensions</b>	<b>12</b>
<b>4. GL865-DUAL/QUAD V3 module connections</b>	<b>13</b>
4.1. PIN-OUT	13
4.2. Pin Layout	16
<b>5. Hardware Commands</b>	<b>17</b>
5.1. Auto-Turning ON the GL865-DUAL/QUAD V3	17
5.2. Turning OFF the GL865-DUAL/QUAD V3	19
5.3. Resetting the GL865-DUAL/QUAD V3	21
5.3.1. Hardware Unconditional restart	21
<b>6. Power Supply</b>	<b>23</b>
6.1. Power Supply Requirements	23
6.2. Power Consumption	24
6.3. General Design Rules	25
6.3.1. Electrical Design Guidelines	25
6.3.2. Thermal Design Guidelines	28
6.3.3. Power Supply PCB layout Guidelines	29
<b>7. Antenna</b>	<b>30</b>
7.1. GSM Antenna Requirements	30
7.1.1. GL865-DUAL/QUAD V3 Antenna – PCB line Guidelines	30
7.2. PCB Design Guidelines	32



7.2.1.	Transmission line design . . . . .	32
7.2.2.	Transmission line measurements . . . . .	33
7.3.	GSM Antenna - Installation Guidelines . . . . .	35
<b>8.</b>	<b>Logic level specifications . . . . .</b>	<b>36</b>
8.1.	Reset signal . . . . .	37
<b>9.</b>	<b>Serial Ports . . . . .</b>	<b>38</b>
9.1.	MODEM SERIAL PORT . . . . .	38
9.2.	RS232 level translation . . . . .	40
<b>10.</b>	<b>Audio Section Overview . . . . .</b>	<b>42</b>
10.1.	MIC connection . . . . .	42
10.2.	LINE-IN connection . . . . .	43
10.3.	EAR connection . . . . .	45
10.4.	Electrical Characteristics . . . . .	47
10.4.1.	Input Lines . . . . .	47
10.4.2.	Output Lines . . . . .	48
<b>11.</b>	<b>General Purpose I/O . . . . .</b>	<b>49</b>
11.1.	GPIO Logic levels . . . . .	50
11.2.	Using a GPIO Pad as INPUT . . . . .	51
11.3.	Using a GPIO Pad as OUTPUT . . . . .	51
11.4.	Using the RF Transmission Control GPIO4 . . . . .	51
11.5.	Using the RFTXMON Output GPIO5 . . . . .	51
11.6.	Using the Alarm Output GPIO6 . . . . .	52
11.7.	Using the Buzzer Output GPIO7 . . . . .	52
11.8.	Magnetic Buzzer Concepts . . . . .	53
11.8.1.	Short Description . . . . .	53
11.8.2.	Frequency Behavior . . . . .	54
11.8.3.	Power Supply Influence . . . . .	54
11.8.4.	Working Current Influence . . . . .	54
11.9.	STAT LED Indication of network service availability . . . . .	55
11.10.	SIMIN detect function . . . . .	56
11.11.	RTC Bypass out . . . . .	56



- 11.12. SIM Holder Implementation . . . . . 56
- 12. DAC and ADC section . . . . . 57**
  - 12.1. DAC Converter . . . . . 57
    - 12.1.1. Description . . . . . 57
    - 12.1.2. Enabling DAC . . . . . 58
    - 12.1.3. Low Pass Filter Example . . . . . 58
  - 12.2. ADC Converter . . . . . 59
    - 12.2.1. Description . . . . . 59
    - 12.2.2. Using ADC Converter . . . . . 59
- 13. Mounting the GL865-DUAL/QUAD V3 on your Board . . . . . 60**
  - 13.1. General . . . . . 60
  - 13.2. Module finishing & dimensions . . . . . 60
  - 13.3. Recommended foot print for the application . . . . . 61
  - 13.4. Stencil . . . . . 61
  - 13.5. PCB pad design . . . . . 62
  - 13.6. Recommendations for PCB pad dimensions (mm): . . . . . 62
  - 13.7. Solder paste . . . . . 64
  - 13.8. GL865-DUAL/QUAD V3 Solder reflow . . . . . 64
  - 13.9. Debug of the GL865-DUAL/QUAD V3 in production . . . . . 65
- 14. Packing system . . . . . 66**
  - 14.1. Packing on tray . . . . . 66
  - 14.2. Packing on reel . . . . . 68
    - 14.2.1. Carrier tape detail . . . . . 69
    - 14.2.2. Carrier tape detail . . . . . 69
  - 14.3. Moisture sensibility . . . . . 70
- 15. Conformity Assessment Issues . . . . . 71**
  - 15.1. GL865-DUAL V3 . . . . . 73
  - 15.2. GL865-QUAD V3 . . . . . 74
- 16. Safety Recommendations . . . . . 77**
- 17. Document History . . . . . 78**



# 1. Introduction

## 1.1. Scope

The aim of this document is the description of some hardware solutions useful for developing a product with the Telit GL865-DUAL/QUAD V3 module.

## 1.2. Audience

This document is intended for Telit customers, who are integrators, about to implement their applications using our GL865-DUAL/QUAD V3 modules.

## 1.3. Contact Information, Support

For general contact, technical support, to report documentation errors and to order manuals, contact Telit Technical Support Center (TTSC) at:

[TS-EMEA@telit.com](mailto:TS-EMEA@telit.com)  
[TS-NORTHAMERICA@telit.com](mailto:TS-NORTHAMERICA@telit.com)  
[TS-LATINAMERICA@telit.com](mailto:TS-LATINAMERICA@telit.com)  
[TS-APAC@telit.com](mailto:TS-APAC@telit.com)

Alternatively, use:

<http://www.telit.com/en/products/technical-support-center/contact.php>

For detailed information about where you can buy the Telit modules or for recommendations on accessories and components visit:

<http://www.telit.com>

To register for product news and announcements or for product questions contact Telit Technical Support Center (TTSC).

Our aim is to make this guide as helpful as possible. Keep us informed of your comments and suggestions for improvements.

Telit appreciates feedback from the users of our information.





## 1.4. Document Organization

This document contains the following chapters:

Chapter 1: “Introduction” provides a scope for this document, target audience, contact and support information, and text conventions.

Chapter 2: “Overview” provides an overview of the document.

Chapter 3: “GL865-DUAL/QUAD V3 Mechanical Dimensions”

Chapter 4: “GL865-DUAL/QUAD V3 Module Connections” deals with the pin out configuration and layout.

Chapter 5: “Hardware Commands” How to operate on the module via hardware.

Chapter 6: “Power supply” Power supply requirements and general design rules.

Chapter 7: “Antenna” The antenna connection and board layout design are the most important parts in the full product design.

Chapter 8: “Logic Level specifications” Specific values adopted in the implementation of logic levels for this module.

Chapter 9: “Serial ports” The serial port on the Telit GL865-DUAL/QUAD V3 is the core of the interface between the module and OEM hardware

Chapter 10: “Audio Section overview” Refers to the audio blocks of the Base Band Chip of the GL865-DUAL/QUAD V3 Telit Modules.

Chapter 11: “General Purpose I/O” How the general purpose I/O pads can be configured.

Chapter 12 “DAC and ADC Section” Deals with these two kind of converters.

Chapter 13: “Mounting the GL865-DUAL/QUAD V3 on the application board” Recommendations and specifics on how to mount the module on the user’s board.

Chapter 14: “Packaging system” Recommendations and specifics on how the system is packaged.

Chapter 15: “Conformity Assessment Issues”

Chapter 16: “Safety Recommendations”

Chapter 17: “Document History” Holds all document changes



## 1.5. Text Conventions



**Danger – This information MUST be followed or catastrophic equipment failure or bodily injury may occur.**



**Caution or Warning – Alerts the user to important points about integrating the module, if these points are not followed, the module and end user equipment may fail or malfunction.**



**Tip or Information – Provides advice and suggestions that may be useful when integrating the module.**

All dates are in ISO 8601 format, i.e. YYYY-MM-DD.

## 1.6. Related Documents

- Telit's GSM/GPRS Family Software User Guide, 1vv0300784
- Audio settings application note , 80000NT10007a
- Digital Voice Interface Application Note, 80000NT10004a
- GL865-DUAL/QUAD V3 Product description, 80400ST10120a
- SIM Holder Design Guides, 80000NT10001a
- AT Commands Reference Guide, 80000ST10025a
- Telit EVK2 User Guide, 1vv0300704



## 2. Overview

The aim of this document is the description of some hardware solutions useful for developing a product with the Telit GL865-DUAL/QUAD V3 module.

In this document all the basic functions of a mobile phone will be taken into account; for each one of them a proper hardware solution will be suggested and eventually the wrong solutions and common errors to be avoided will be evidenced. Obviously this document cannot embrace all hardware solutions and products that may be designed. Avoiding the wrong solutions shall be considered as mandatory. While the suggested hardware configurations shall not be considered mandatory, the information given shall be used as a guide and a starting point for properly developing your product with the Telit GL865-DUAL/QUAD V3 module. For further hardware details that may not be explained in this document refer to the Telit GL865-DUAL/QUAD V3 Product Description document where all the hardware information is reported.



---

### NOTICE:

The integration of the GSM/GPRS **GL865-DUAL/QUAD V3** cellular module within user application shall be done according to the design rules described in this manual.

---

The information presented in this document is believed to be accurate and reliable. However, no responsibility is assumed by Telit Communications S.p.A. for its use, nor any infringement of patents or other rights of third parties which may result from its use. No license is granted by implication or otherwise under any patent rights of Telit Communications S.p.A. other than for circuitry embodied in Telit products. This document is subject to change without notice.



### 3. GL865-DUAL/QUAD V3 Mechanical Dimensions

The GL865-DUAL/QUAD V3 overall dimensions are:

- Length: 24.4 mm
- Width: 24.4 mm
- Thickness: 2.6 mm
- Weight 2.8 g

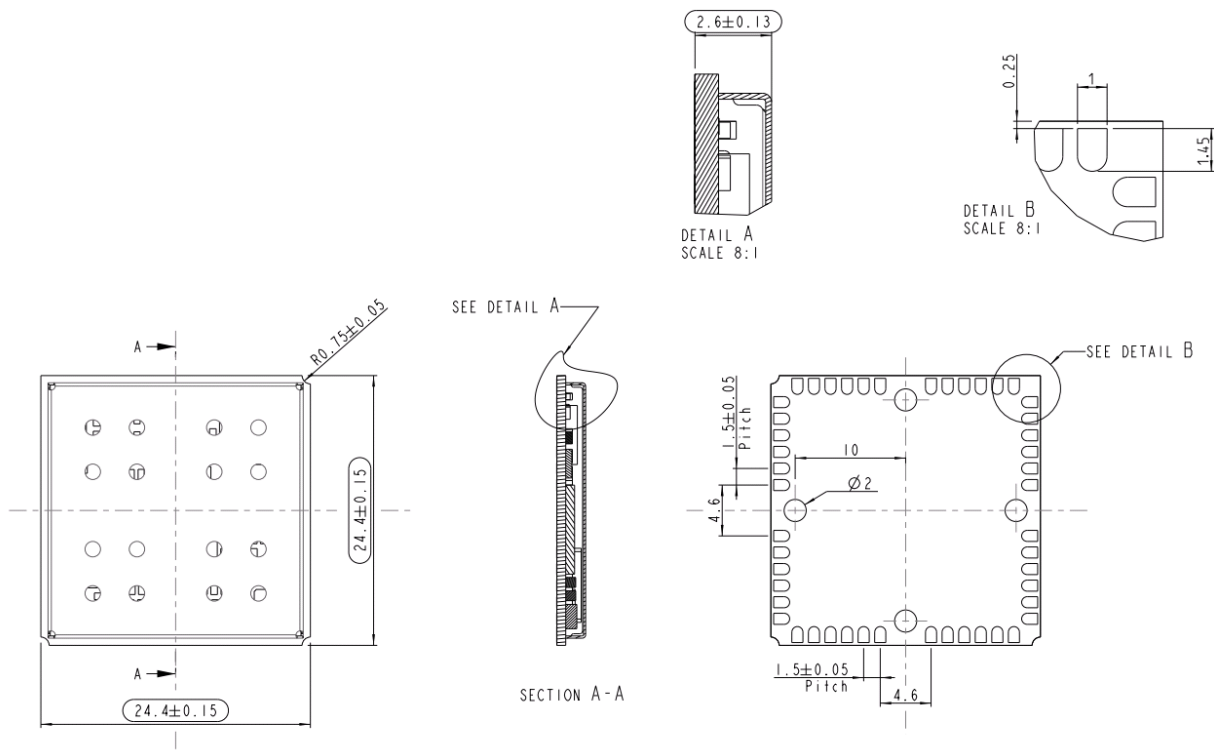

## 4. GL865-DUAL/QUAD V3 module connections

### 4.1. PIN-OUT

Pad	Signal	I/O	Function	Note	Type
<b>Audio</b>					
20	EAR-	AO	Earphone signal output, phase -		Audio
21	EAR+	AO	Earphone signal output, phase +		Audio
22	MIC-	AI	Mic. signal input; phase-		Audio
24	MIC+	AI	Mic. signal input; phase+		Audio
23	AGND	-	Analog Ground		-
<b>SIM card interface</b>					
9	SIMVCC	-	External SIM signal – Power supply for the SIM		1,8 / 3V
10	SIMRST	O	External SIM signal – Reset		1,8 / 3V
11	SIMCLK	O	External SIM signal – Clock		1,8 / 3V
12	SIMIO	I/O	External SIM signal – Data I/O	4.7k Pull up	1,8 / 3V
X All GPIO can be program med	SIMIN	I	Presence SIM input		CMOS 1.8V
<b>Trace</b>					
44	RXD_AUX	I	Auxiliary UART (RX Data)		CMOS 1.8V
45	TXD_AUX	O	Auxiliary UART (TX Data)		CMOS 1.8V
<b>Prog. / Data + HW Flow Control</b>					
1	C109/DCD/GPO	O	Output for Data carrier detect signal (DCD) to DTE / GP output		CMOS 1.8V
2	C125/RING/GPO	O	Output for Ring indicator signal (RI) to DTE / GP output		CMOS 1.8V
3	C107/DSR/GPO	O	Output for Data set ready signal (DSR) to DTE / GP output		CMOS 1.8V
4	C108/DTR/GPI	I	Input for Data terminal ready signal (DTR) from DTE / GP input		CMOS 1.8V
5	C105/RTS/GPI	I	Input for Request to send signal (RTS) from DTE / GP input		CMOS 1.8V
6	C106/CTS/GPO	O	Output for Clear to send signal (CTS) to DTE / GP output		CMOS 1.8V
7	C103/TXD	I	Serial data input (TXD) from DTE		CMOS 1.8V
8	C104/RXD	O	Serial data output to DTE		CMOS 1.8V
<b>DAC and ADC</b>					
13	ADC_IN1	AI	Analog/Digital converter input		A/D
14	ADC_IN2	AI	Analog/Digital converter input		A/D
15	DAC_OUT	AO	Digital/Analog converter output		D/A
<b>Miscellaneous Functions</b>					
30	VRTC	AO	VRTC Backup		Power
47	RESET*	I	Reset input		CMOS 1.8V
43	V_AUX / PWRMON	O	1.8V stabilized output I <sub>max</sub> =100mA / Power ON monitor		Power Out 1.8V
34	Antenna	I/O	Antenna pad – 50 Ω		RF



Pad	Signal	I/O	Function	Note	Type
<b>GPIO</b>					
42	GPIO_01 / DVI_WA0	I/O	GPIO01 Configurable GPIO / Digital Audio Interface (WA0)		CMOS 1.8V
41	GPIO_02 / JDR / DVI_RX	I/O	GPIO02 I/O pin / Jammer Detect Report / Digital Audio Interface (RX)		CMOS 1.8V
40	GPIO_03 / DVI_TX	I/O	GPIO03 GPIO I/O pin / Digital Audio Interface (TX)		CMOS 1.8V
39	GPIO_04 / TX Disable / DVI_CLK	I/O	GPIO04 Configurable GPIO / TX Disable input / Digital Audio Interface (CLK)		CMOS 1.8V
29	GPIO_05 / RFTXMON	I/O	GPIO05 Configurable GPIO / Transmitter ON monitor		CMOS 1.8V
28	GPIO_06 / ALARM	I/O	GPIO06 Configurable GPIO / ALARM		CMOS 1.8V
27	GPIO_07 / BUZZER	I/O	GPIO07 Configurable GPIO / Buzzer		CMOS 1.8V
26	GPIO_08 / STAT_LED	I/O	GPIO08 Configurable GPIO / Digital Audio Interface (CLK)		CMOS 1.8V
<b>Power Supply</b>					
38	VBATT	-	Main power supply (Baseband)		Power
37	VBATT_PA	-	Main power supply (Radio PA)		Power
23	AGND	-	AF Signal Ground (see audio section)		AF Signal
32	GND	-	Ground		Power
33	GND	-	Ground		Power
35	GND	-	Ground		Power
36	GND	-	Ground		Power
46	GND	-	Ground		Power
<b>RESERVED</b>					
48		-			
16		-			
17		-			
18		-			
19		-			
25		-			
31		-			



**WARNING:**

Reserved pins must not be connected.





**NOTE:**

If not used, almost all pins should be left disconnected. The only exceptions are the following pins:

Pin	signal
38, 37	VBATT & VBATT_PA
32, 33, 35, 36, 46	GND
23	AGND
7	TXD
8	RXD
5	RTS
43	V_AUX / PWRMON
47	RESET*
45	TXD_AUX
44	RXD_AUX



## 4.2. Pin Layout

### TOP VIEW

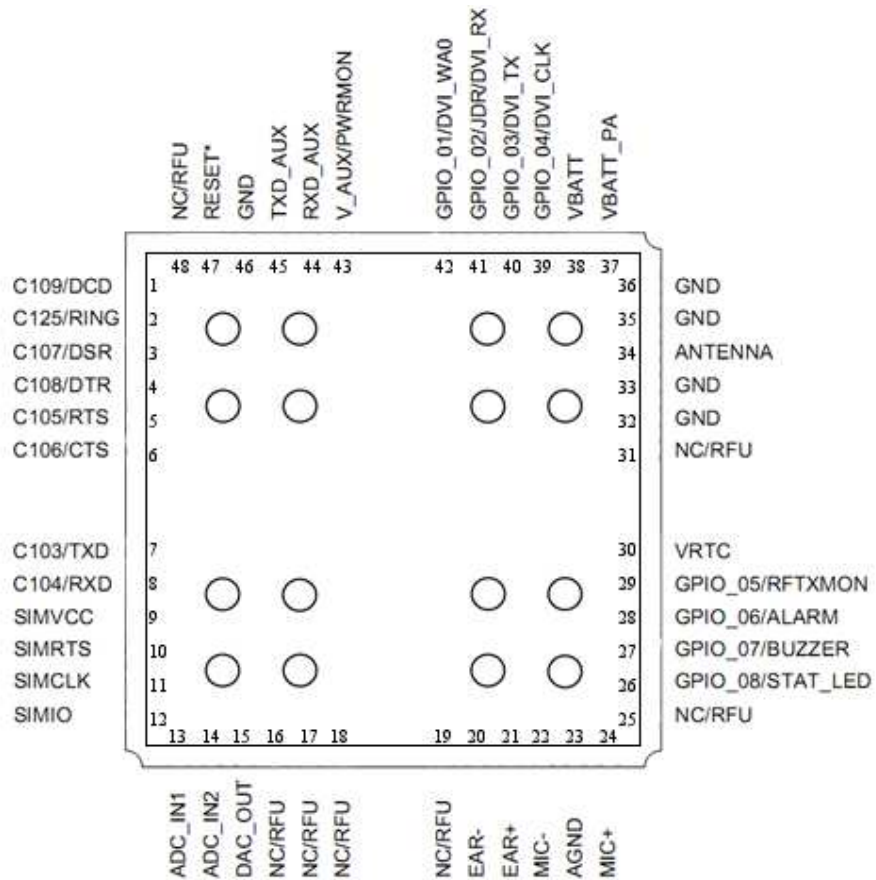

#### NOTE:

The pins defined as NC/RFU shall be considered RESERVED and must not be connected to any pin in the application.





## 5. Hardware Commands

### 5.1. Auto-Turning ON the GL865-DUAL/QUAD V3

To Auto-turn on the GL865-DUAL/QUAD V3, the power supply must be applied on the power pins VBATT and VBATT\_PA, after 1000 m-seconds, the V\_AUX / PWRMON pin will be at the high logic level and the module can be considered fully operating.

When the power supply voltage is between 3.22V and 3.4V, after 5000 m-seconds, the V\_AUX / PWRMON pin will be at the high logic level and the module can be considered fully operating.

The following flow chart shows the proper turn on procedure:

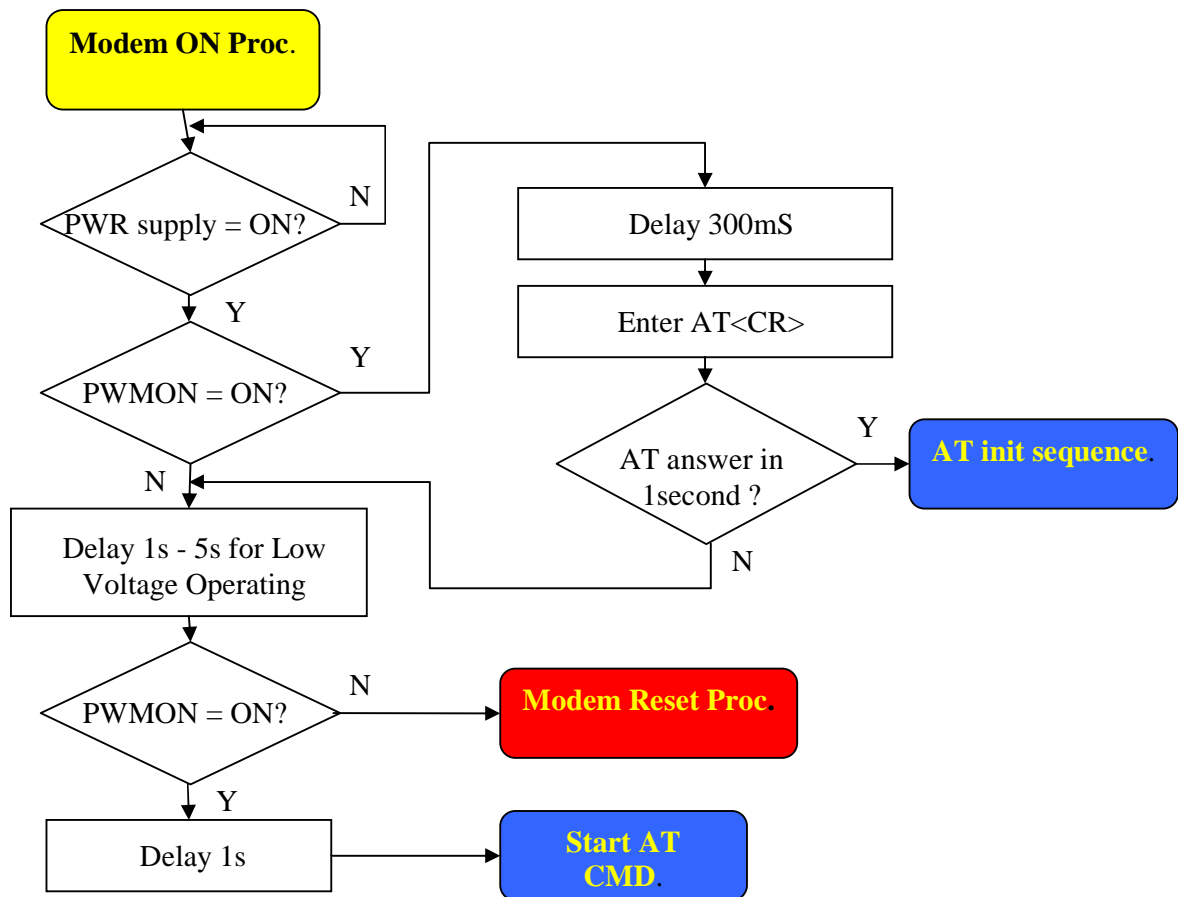



**NOTE:**

The power supply must be applied either at the same time on pins VBATT and VBATT\_PA, or first applied on VBATT\_PA and then on VBATT. The opposite sequence shall be avoided. The reverse procedure applies for powering down the module: first disconnect VBATT, then VBATT\_PA, or both at once.



**NOTE:**

In order to prevent a back powering effect it is recommended to avoid having any HIGH logic level signal applied to the digital pins of the GL865-DUAL/QUAD V3 when the module is powered OFF or during an ON/OFF transition.

A flow chart showing the AT commands managing procedure is displayed below:

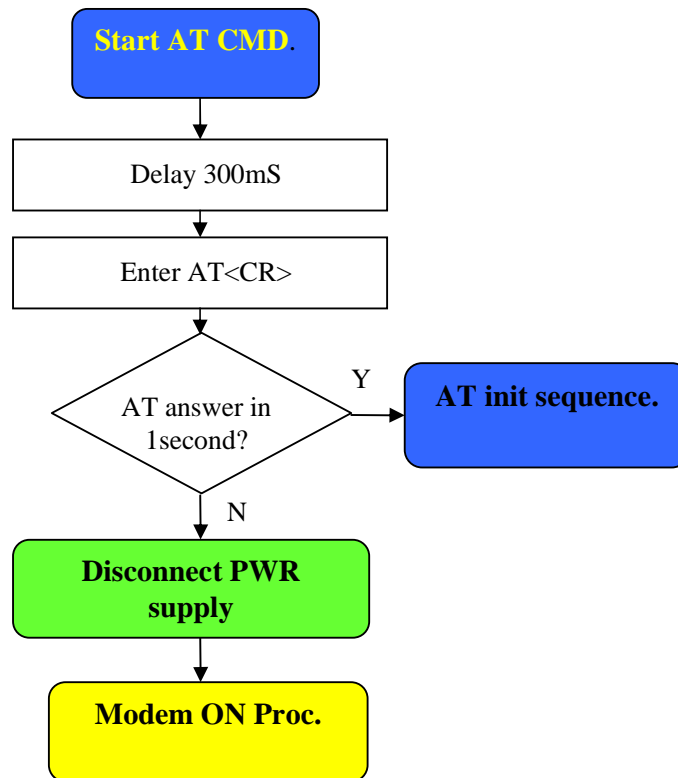

## 5.2. Turning OFF the GL865-DUAL/QUAD V3

Turning off of the device can be done in two ways:

- General turn OFF
- Processor turn OFF

**General turn OFF** – disconnect the power supply from the both power pins VBATT and VBATT\_PA at the same time. In this case all parts of the module are in OFF condition, no power consumption is present.

**Processor turn OFF** – disconnect the power supply only from the power pin VBATT, the power pin VBATT\_PA can be connected to power supply, in this case a low, about 30uA, power consumption is present

Before either of both OFF procedures is applied, the AT#SYSHALT AT command must be sent (see AT Commands Reference Guide, 80000ST10025a), after the OK response message, wait for 10 seconds, then the module can be consider fully not operating and at this moment is possible disconnect the Power Supply.

The following flow chart shows the proper turnoff procedure:

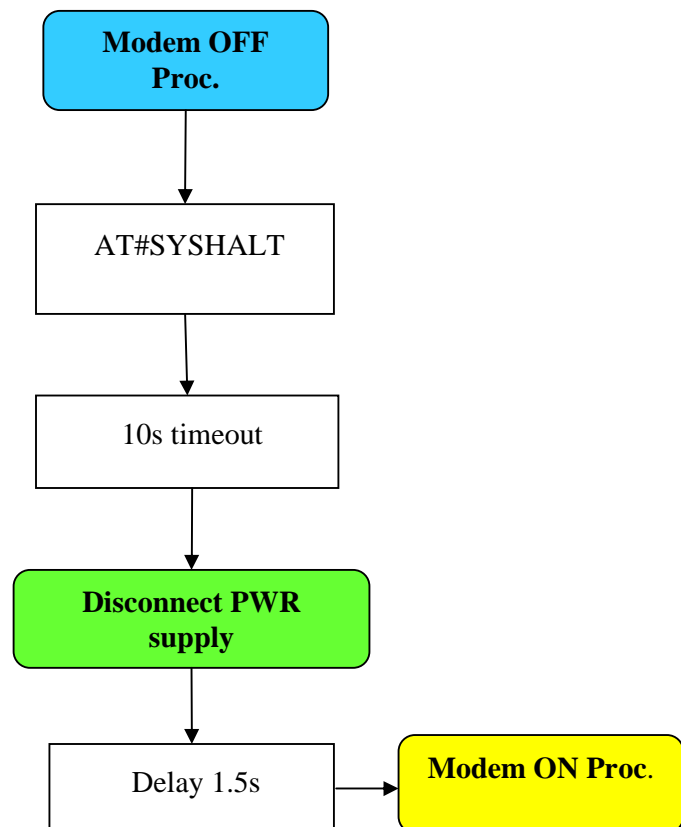



---

**WARNING:**

POWERMON can be used to monitor only the power on but it cannot be used to monitor the power off because it remains high. Instead AT#SYSHALT works in the same way as previous GL865-DUAL/QUAD.

---



---

**NOTE:**

In order to prevent a back powering effect it is recommended to avoid having any HIGH logic level signal applied to the digital pins of the GL865-DUAL/QUAD V3 when the module is powered off or during an ON/OFF transition.

---



## 5.3. Resetting the GL865-DUAL/QUAD V3

### 5.3.1. Hardware Unconditional restart



#### WARNING:

The hardware unconditional Restart must not be used during normal operation of the device since it does not detach the device from the network. It shall be kept as an emergency exit procedure to be done in the rare case that the device gets stuck waiting for some network or SIM responses.

To unconditionally reboot the GL865-DUAL/QUAD V3, the pad RESET\* must be tied low for at least 200 milliseconds and then released.

The maximum current that can be drained from the ON\* pad is 0,15 mA.



#### NOTE:

Do not use any pull up resistor on the RESET\* line nor any totem pole digital output. Using pull up resistor may bring to latch up problems on the GL865-DUAL/QUAD V3 power regulator and improper functioning of the module. The line RESET\* must be connected only in open collector configuration; the transistor must be connected as close as possible to the RESET\* pin.

#### TIP:

The unconditional hardware restart must always be implemented on the boards and the software must use it as an emergency exit procedure.

A simple circuit to do it is:

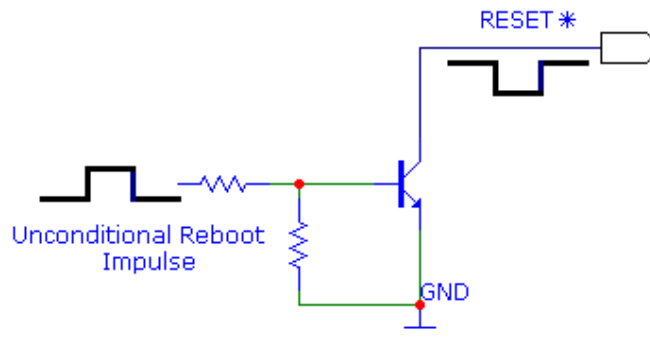

In the following flow chart is detailed the proper restart procedure:



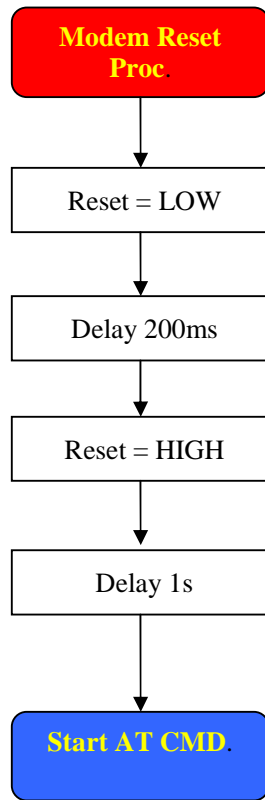

**NOTE:**

In order to prevent a back powering effect it is recommended to avoid having any HIGH logic level signal applied to the digital pins of the GL865-DUAL/QUAD V3 when the module is powered OFF or during an ON/OFF transition.



## 6. Power Supply

The power supply circuitry and board layout are a very important part in the full product design and they strongly reflect on the product overall performance, hence read the requirements carefully and the guidelines that will follow for a proper design.

### 6.1. Power Supply Requirements

The external power supply must be connected to VBATT & VBATT\_PA signals and must fulfill the following requirements:

POWER SUPPLY	
Nominal Supply Voltage	3.8 V
Normal Operating Voltage Range	3.40 V ÷ 4.20 V
Extended Operating Voltage Range	3.10 V ÷ 4.50 V



**NOTE:**

The Operating Voltage Range MUST never be exceeded; care must be taken when designing the application’s power supply section to avoid having an excessive voltage drop.

If the voltage drop is exceeding the limits it could cause a Power Off of the module.

The Power supply must be higher than 3.22 V to power on the module.



**NOTE:**

Overshoot voltage (regarding MAX Extended Operating Voltage) and drop in voltage (regarding MIN Extended Operating Voltage) MUST never be exceeded;

The “Extended Operating Voltage Range” can be used only with complete assumption and application of the HW User guide suggestions.



**NOTE:**

When the power supply voltage is between 3.22V and 3.4V, after 5000 m-seconds, the V\_AUX / PWRMON pin will be at the high logic level and the module can be consider fully operating. See Par. 5.1.



## 6.2. Power Consumption

The GL865-DUAL/QUAD V3 power consumptions are:

GL865-DUAL/QUAD V3		
Mode	Average (mA)	Mode description
<b>SWITCHED OFF</b>		
Switched Off	Typical 2uA max 20uA	Module power supplied only on VBATT_PA pin, the VBATT pin is not power supplied.
Switched Off with AT#SYSHALT	<500uA	Module power supplied on VBATT_PA pin and VBATT pin, the command AT#SYSHALT is applied.
<b>IDLE mode</b>		
AT+CFUN=1	10	Normal mode: full functionality of the module
AT+CFUN=4	10	Disabled TX and RX; module is not registered on the network
AT+CFUN=0 or =5	2	Paging Multiframe 2
	1.7	Paging Multiframe 3
	1,5	Paging Multiframe 4
	0,9	Paging Multiframe 9
<b>CSD TX and RX mode</b>		
GSM900 CSD PL5	200	GSM VOICE CALL
DCS1800 CSD PL0	150	
<b>GPRS (class 1) 1TX + 1RX</b>		
GSM900 PL5	200	GPRS Sending data mode
DCS1800 PL0	140	
<b>GPRS (class 10) 2TX + 3RX</b>		
GSM900 PL5	330	GPRS Sending data mode
DCS1800 PL0	250	

The GSM system is made in a way that the RF transmission is not continuous, but it is packed into bursts at a base frequency of approx. 217 Hz, and the relative current peaks can be as high as about 2A. Therefore the power supply has to be designed to withstand these current peaks without big voltage drops; this means that both the electrical design and the board layout must be designed for this current flow.

If the layout of the PCB is not well designed a strong noise floor is generated on the ground and the supply; this will reflect on all the audio paths producing an audible annoying noise at approx. 217 Hz; if the voltage drop during the peak current absorption is too much, then the device may even shutdown as a consequence of the supply voltage drop.



### NOTE:

The electrical design for the Power supply should be made ensuring it will be capable of a peak current output of at least 2 A.





## 6.3. General Design Rules

The principal guidelines for the Power Supply Design embrace three different design steps:

- the electrical design
- the thermal design
- the PCB layout.

### 6.3.1. Electrical Design Guidelines

The electrical design of the power supply depends strongly on the power source from which this power is drained. We will distinguish them into three categories:

- +5V input (typically PC internal regulator output)
- +12V input (typically automotive)
- Battery

#### 6.3.1.1. +5V input Source Power Supply Design Guidelines

- The desired output for the power supply is 3.8V, hence there's not a big difference between the input source and the desired output and a linear regulator can be used. A switching power supply will not be suited because of the low drop out requirements.
- When using a linear regulator, a proper heat sink shall be provided in order to dissipate the power generated.
- A Bypass low ESR capacitor of adequate capacity must be provided in order to cut the current absorption peaks close to the GL865-DUAL/QUAD V3, a 100µF tantalum capacitor is usually suited.
- Make sure the low ESR capacitor on the power supply output (usually a tantalum one) is rated at least 10V.
- A protection diode should be inserted close to the power input, in order to save the GL865-DUAL/QUAD V3 from power polarity inversion.

An example of linear regulator with 5V input is:

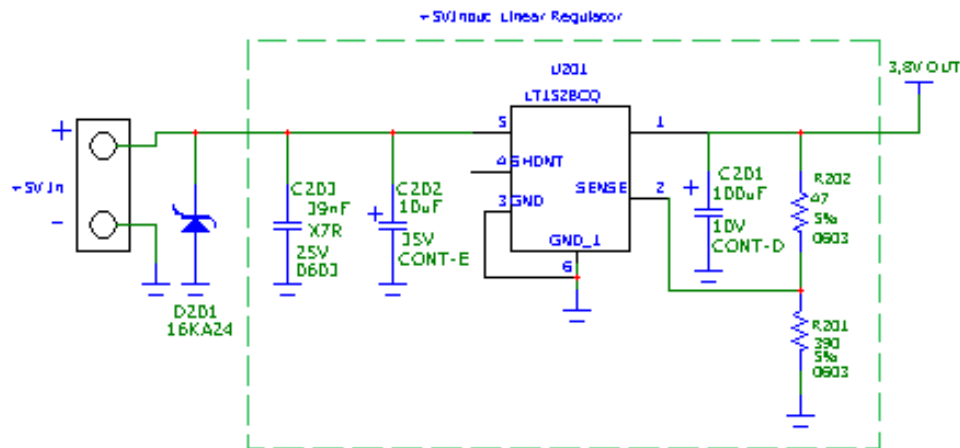

### 6.3.1.2. + 12V input Source Power Supply Design Guidelines

- The desired output for the power supply is 3.8V, hence due to the big difference between the input source and the desired output, a linear regulator is not suited and shall not be used. A switching power supply will be preferable because of its better efficiency especially with the 2A peak current load represented by the GL865-DUAL/QUAD V3.
- When using a switching regulator, a 500kHz or more switching frequency regulator is preferable because of its smaller inductor size and its faster transient response. This allows the regulator to respond quickly to the current peaks absorption.
- In any case the frequency and Switching design selection is related to the application to be developed due to the fact the switching frequency could also generate EMC interferences.
- For car PB battery the input voltage can rise up to 15,8V and this should be kept in mind when choosing components: all components in the power supply must withstand this voltage.
- A Bypass low ESR capacitor of adequate capacity must be provided in order to cut the current absorption peaks, a 100µF tantalum capacitor is usually suited.
- Make sure the low ESR capacitor on the power supply output (usually a tantalum one) is rated at least 10V.
- For Car applications a spike protection diode should be inserted close to the power input, in order to clean the supply from spikes.
- A protection diode should be inserted close to the power input, in order to save the GL865-DUAL/QUAD V3 from power polarity inversion. This can be the same diode as for spike protection.

An example of switching regulator with 12V input is in the below schematic:

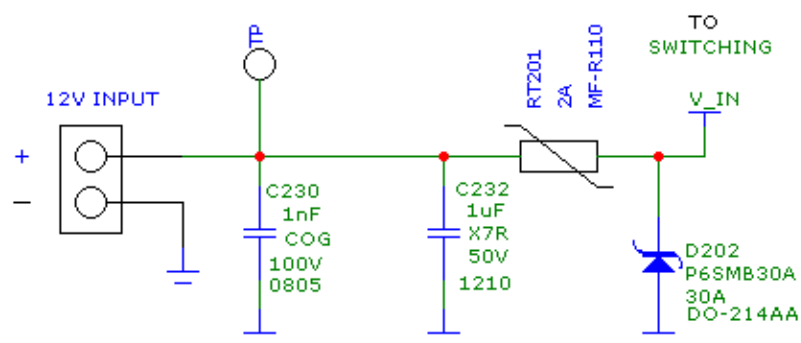

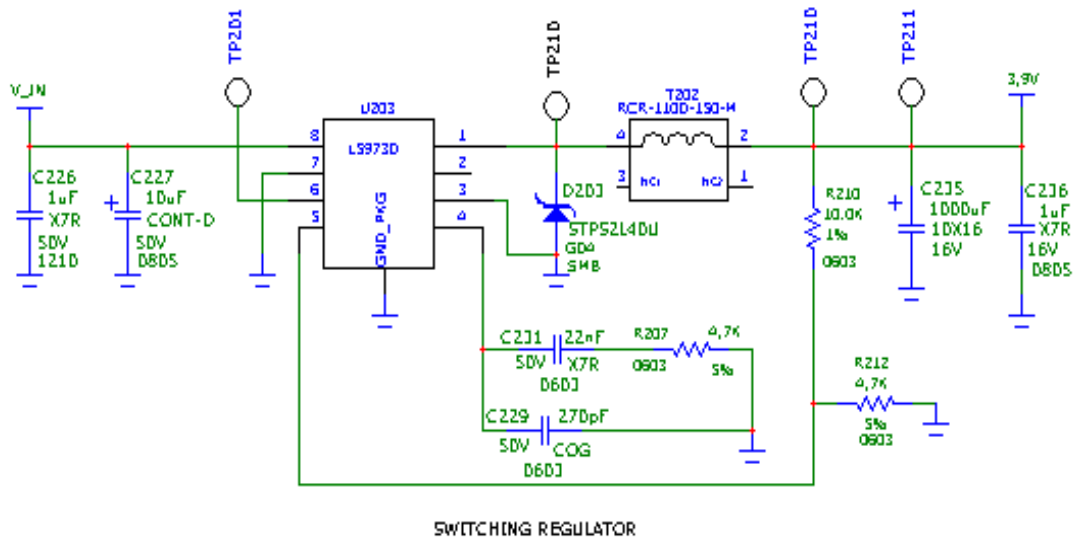

6.3.1.3.

**Battery Source Power Supply Design Guidelines**

- The desired nominal output for the power supply is 3.8V and the maximum voltage allowed is 4.2V, hence a single 3.7V Li-Ion cell battery type is suited for supplying the power to the Telit GL865-DUAL/QUAD V3 module.



**WARNING:**

The three cells Ni/Cd or Ni/MH 3.6 V Nom. battery types or 4V PB types ***MUST NOT BE USED DIRECTLY*** since their maximum voltage can rise over the absolute maximum voltage for the GL865-DUAL/QUAD V3 and damage it.



**NOTE:**

DON'T USE any Ni-Cd, Ni-MH, and Pb battery types directly connected with GL865-DUAL/QUAD V3. Their use can lead to overvoltage on the GL865-DUAL/QUAD V3 and damage it. USE ONLY Li-Ion battery types.

- A Bypass low ESR capacitor of adequate capacity must be provided in order to cut the current absorption peaks, a 100µF tantalum capacitor is usually suited.
- Make sure the low ESR capacitor (usually a tantalum one) is rated at least 10V.
- A protection diode should be inserted close to the power input, in order to save the GL865-DUAL/QUAD V3 from power polarity inversion. Otherwise the battery connector should be done in a way to avoid polarity inversions when connecting the battery.
- The battery capacity must be at least 500mAh in order to withstand the current peaks of 2A; the suggested capacity is from 500mAh to 1000mAh.



### 6.3.2. Thermal Design Guidelines

The thermal design for the power supply heat sink should be done with the following specifications:  
See Par. 6.2 Power Consumption



---

**NOTE:**

The average consumption during transmissions depends on the power level at which the device is requested to transmit by the network. The average current consumption hence varies significantly.

---

Considering the very low current during idle, especially if Power Saving function is enabled, it is possible to consider from the thermal point of view that the device absorbs current significantly only during calls.

For the heat generated by the GL865-DUAL/QUAD V3, you can consider it to be during transmission 1W max during CSD/VOICE calls and 2W max during class10 GPRS upload. This generated heat will be mostly conducted to the ground plane under the GL865-DUAL/QUAD V3; you must ensure that your application can dissipate it.



### 6.3.3. Power Supply PCB layout Guidelines

As seen on the electrical design guidelines the power supply shall have a low ESR capacitor on the output to cut the current peaks and a protection diode on the input to protect the supply from spikes and polarity inversion. The placement of these components is crucial for the correct working of the circuitry. A misplaced component can be useless or can even decrease the power supply performance.

- The Bypass low ESR capacitor must be placed close to the Telit GL865-DUAL/QUAD V3 power input pads or in the case the power supply is a switching type it can be placed close to the inductor to cut the ripple provided the PCB trace from the capacitor to the GL865-DUAL/QUAD V3 is wide enough to ensure a dropless connection even during the 2A current peaks.
- The protection diode must be placed close to the input connector where the power source is drained.
- The PCB traces from the input connector to the power regulator IC must be wide enough to ensure no voltage drops occur when the 2A current peaks are absorbed. Note that this is not made in order to save power loss but especially to avoid the voltage drops on the power line at the current peaks frequency of approx. 217 Hz that will reflect on all the components connected to that supply, introducing the noise floor at the burst base frequency. For this reason while a voltage drop of 300-400 mV may be acceptable from the power loss point of view, the same voltage drop may not be acceptable from the noise point of view. If your application doesn't have audio interface but only uses the data feature of the Telit GL865-DUAL/QUAD V3, then this noise is not so disturbing and power supply layout design can be more forgiving.
- The PCB traces to the GL865-DUAL/QUAD V3 and the Bypass capacitor must be wide enough to ensure no significant voltage drops occur when the 2A current peaks are absorbed. This is for the same reason as previous point. Try to keep this trace as short as possible.
- The PCB traces connecting the Switching output to the inductor and the switching diode must be kept as short as possible by placing the inductor and the diode very close to the power switching IC (only for switching power supply). This is done in order to reduce the radiated field (noise) at the switching frequency (100-500 kHz usually).
- The use of a good common ground plane is suggested.
- The placement of the power supply on the board should be done in such a way to guarantee that the high current return paths in the ground plane are not overlapped to any noise sensitive circuitry as the microphone amplifier/buffer or earphone amplifier.
- The power supply input cables should be kept separate from noise sensitive lines such as microphone/earphone cables.



## 7. Antenna

The antenna connection and board layout design are the most important aspect in the full product design as they strongly affect the product overall performance, hence read carefully and follow the requirements and the guidelines for a proper design.

### 7.1. GSM Antenna Requirements

As suggested on the Product Description the antenna and antenna transmission line on PCB for a Telit GL865-DUAL/QUAD V3 device shall fulfill the following requirements:

ANTENNA REQUIREMENTS	
Frequency range	Depending by frequency band(s) provided by the network operator, the customer shall use the most suitable antenna for that/those band(s)
Bandwidth	70 MHz in GSM850, 80 MHz in GSM900, 170 MHz in DCS & 140 MHz PCS band
Impedance	50 Ohm
Input power	> 2 W
VSWR absolute max	≤ 10:1 (limit to avoid permanent damage)
VSWR recommended	≤ 2:1 (limit to fulfill all regulatory requirements)

Furthermore if the devices are developed for the US market and/or Canada market (GL865-QUAD V3 variant only), they shall comply to the FCC and/or IC approval requirements:

Those devices are to be used only for mobile and fixed application. The antenna(s) used for this transmitter must be installed to provide a separation distance of at least 20 cm from all persons and must not be co-located or operating in conjunction with any other antenna or transmitter. End-Users must be provided with transmitter operation conditions for satisfying RF exposure compliance. OEM integrators must ensure that the end user has no manual instructions to remove or install the GL865-QUAD V3. Antennas used for those OEM modules must not exceed 3dBi gain for mobile and fixed operating configurations.

#### 7.1.1. GL865-DUAL/QUAD V3 Antenna – PCB line Guidelines

When using the Telit GL865-DUAL/QUAD V3 module, since there's no antenna connector on the module, the antenna must be connected to the GL865-DUAL/QUAD V3 through the PCB with the antenna pad (**pin 34**).

In the case that the antenna is not directly developed on the same PCB, hence directly connected at the antenna pad of the GL865-DUAL/QUAD V3, then a PCB line is needed in order to connect with it or with its connector.



This transmission line shall fulfill the following requirements:

ANTENNA LINE ON PCB REQUIREMENTS	
<b>Impedance</b>	50 ohm
<b>Max Attenuation</b>	0,3 dB
<b>No coupling with other signals allowed</b>	
<b>Cold End (Ground Plane) of antenna shall be equipotential to the GL865-DUAL/QUAD V3 ground pins</b>	

This transmission line should be designed according to the following guidelines:

- Ensure that the antenna line impedance is 50 ohm;
- Keep the antenna line on the PCB as short as possible, since the antenna line loss shall be less than 0,3 dB;
- Antenna line must have uniform characteristics, constant cross section, avoid meanders and abrupt curves;
- Keep, if possible, one layer of the PCB used only for the Ground plane;
- Surround (on the sides, over and under) the antenna line on PCB with Ground, avoid having other signal tracks facing directly the antenna line track;
- The ground around the antenna line on PCB has to be strictly connected to the Ground Plane by placing vias every 2mm at least;
- Place EM noisy devices as far as possible from GL865-DUAL/QUAD V3 antenna line;
- Keep the antenna line far away from the GL865-DUAL/QUAD V3 power supply lines;
- If you have EM noisy devices around the PCB hosting the GL865-DUAL/QUAD V3, such as fast switching ICs, take care of the shielding of the antenna line by burying it inside the layers of PCB and surround it with Ground planes, or shield it with a metal frame cover.
- If you don't have EM noisy devices around the PCB of GL865-DUAL/QUAD V3, by using a micro strip on the superficial copper layer for the antenna line, the line attenuation will be lower than a buried one;



## 7.2. PCB Design Guidelines

This section explains the suggested design for the transmission line on the customer's application board.

### 7.2.1. Transmission line design

During the design of the GL865-DUAL/QUAD V3 interface board, the placement of components has been chosen properly, in order to keep the line length as short as possible, thus leading to lowest power losses possible. A Grounded Coplanar Waveguide (G-CPW) line has been chosen, since this kind of transmission line ensures good impedance control and can be implemented in an outer PCB layer as needed in this case. A SMA female connector has been used to feed the line.

The interface board is realized on a FR4, 4-layers PCB. Substrate material is characterized by relative permittivity  $\epsilon_r = 4.6 \pm 0.4 @ 1 \text{ GHz}$ ,  $\text{TanD} = 0.019 \div 0.026 @ 1 \text{ GHz}$ .

A characteristic impedance of nearly  $50 \Omega$  is achieved using trace width = 1.1 mm, clearance from coplanar ground plane = 0.3 mm each side. The line uses reference ground plane on layer 3, while copper is removed from layer 2 underneath the line. Height of trace above ground plane is 1.335 mm. Calculated characteristic impedance is  $51.6 \Omega$ , estimated line loss is less than 0.1 dB. The line geometry is shown below:

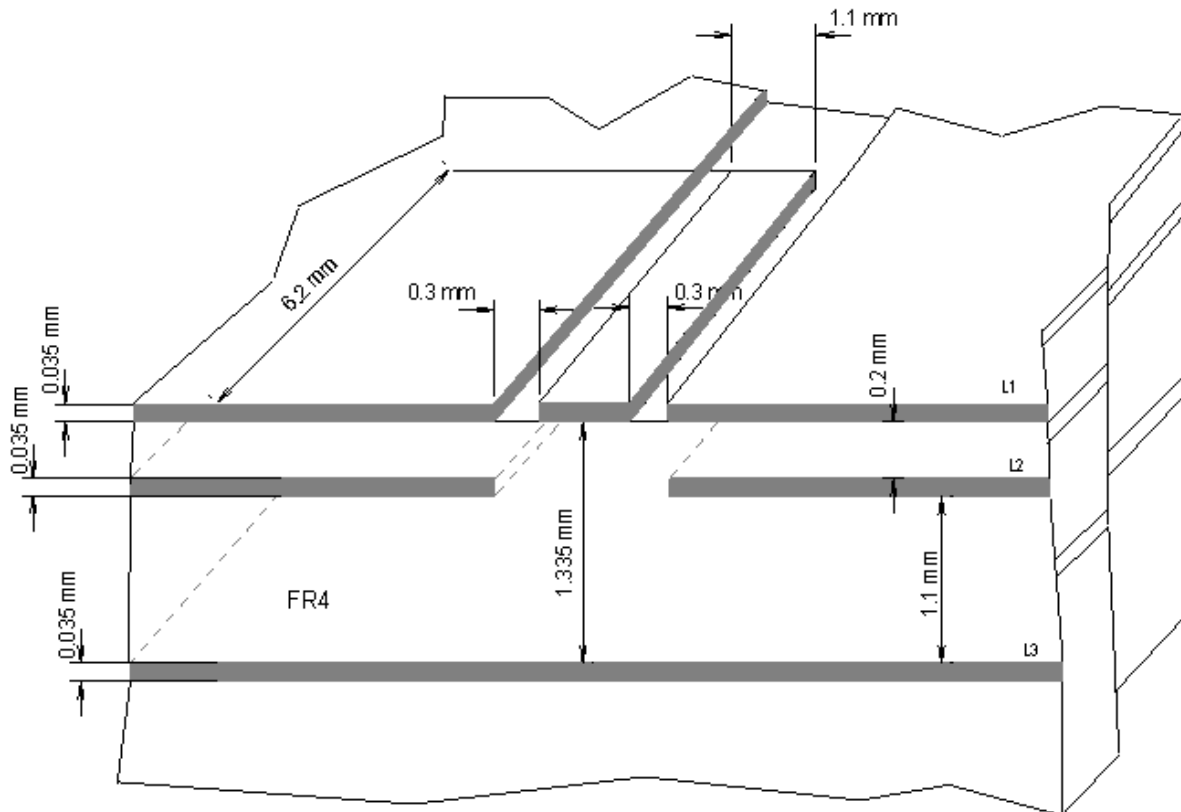



## 7.2.2. Transmission line measurements

HP8753E VNA (Full-2-port calibration) has been used in this measurement session. A calibrated coaxial cable has been soldered at the pad corresponding to GL865-DUAL/QUAD V3 RF output; a SMA connector has been soldered to the board in order to characterize the losses of the transmission line including the connector itself. During Return Loss / impedance measurements, the transmission line has been terminated to 50  $\Omega$  load.

Return Loss plot of line under test is shown below:

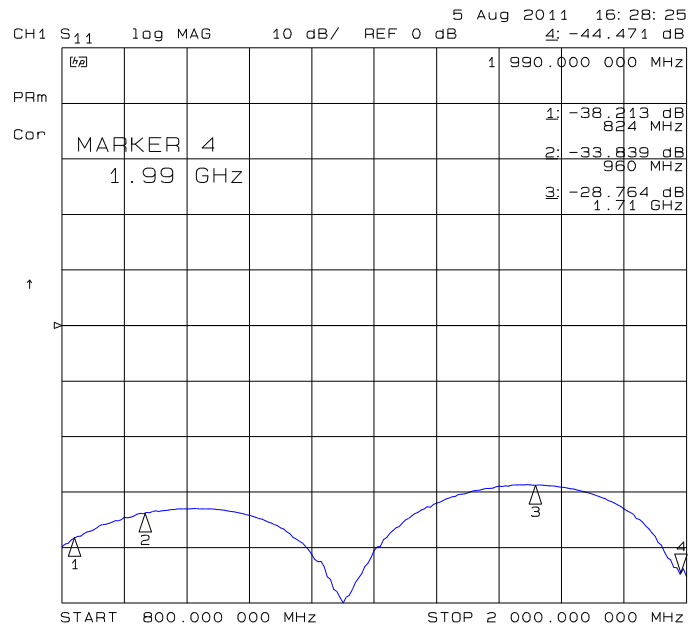

Line input impedance (in Smith Chart format, once the line has been terminated to 50 Ω load) is shown in the following figure:

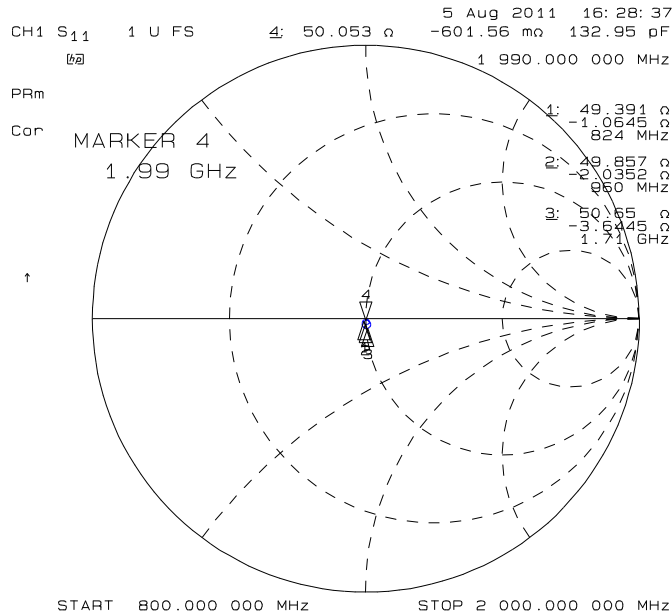

Insertion Loss of G-CPW line plus SMA connector is shown below:

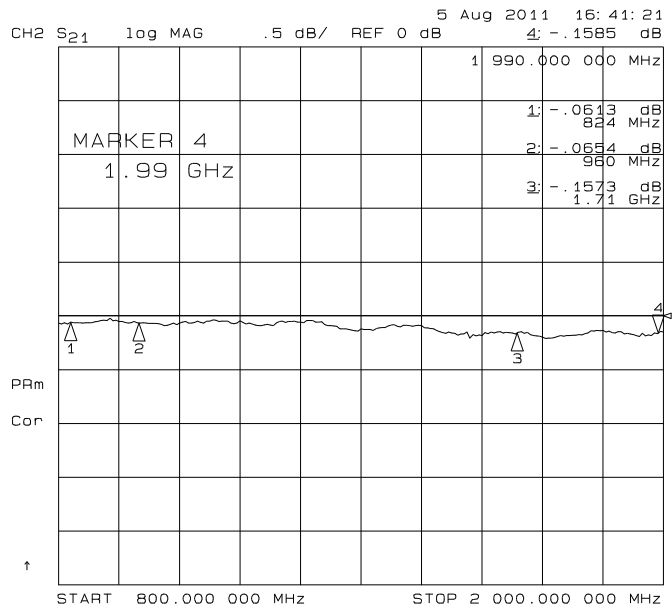

### 7.3. GSM Antenna - Installation Guidelines

- Install the antenna in a place covered by the GSM signal.
- Antenna shall not be installed inside metal cases
- Antenna shall be installed also according to antenna manufacturer instructions.
- Installation should also take in account the R&TTE requirements described in the “Conformity Assessment Issues” chapter



## 8. Logic level specifications

Where not specifically stated, all the interface circuits work at 1.8V CMOS logic levels. The following table shows the logic level specifications used in the GL865-DUAL/QUAD V3 interface circuits:

### Absolute Maximum Ratings -Not Functional

Parameter	Min	Max
Input level on any digital pin (CMOS 1.8) when on	-0.3V	+2.1V

### Operating Range - Interface levels (1.8V CMOS)

Level	Min	Max
Input high level	1.3V	1.9V
Input low level	0V	0.35V
Output high level	1.6V	1.9V
Output low level	0V	0.2V

### Current characteristics

Level	Typical
Output Current	1mA
Input Current	1uA



## 8.1. Reset signal

Signal	Function	I/O	pin
RESET*	Phone reset	I	47

RESET\* is used to reset the GL865-DUAL/QUAD V3. Whenever this signal is pulled low, the GL865-DUAL/QUAD V3 is reset. When the device is reset it stops any operation. After the release of the reset GL865-DUAL/QUAD V3 is unconditionally shut down, without doing any detach operation from the network where it is registered. This behavior is not a proper shut down because any GSM device is requested to issue a detach request on turn off. For this reason the Reset signal must not be used to normally shutting down the device, but only as an emergency exit in the rare case the device remains stuck waiting for some network response.

The RESET\* is internally controlled on start-up to achieve a proper power-on reset sequence, so there's no need to control this pin on start-up. It may only be used to reset a device already on that is not responding to any command.



**NOTE:**

Do not use this signal to power OFF the GL865-DUAL/QUAD V3. Use the ON/OFF procedure to perform this function.

**Reset Signal Operating levels:**

Signal	Min	Max
RESET* Input high	1.8V(NOTE1)	2.1V
RESET* Input low	0V	0.2V

(NOTE1) this signal is internally pulled up so the pin can be left floating if not used.

If unused, this signal may be left unconnected. If used, then it must always be connected with an open collector transistor, to permit to the internal circuitry the power on reset and under voltage lockout functions.



## 9. Serial Ports

The serial port on the GL865-DUAL/QUAD V3 is the core of the interface between the module and OEM hardware.

2 serial ports are available on the module:

- MODEM SERIAL PORT 1 (Main, ASC0)
- MODEM SERIAL PORT 2 (Auxiliary, ASC1)

### 9.1. MODEM SERIAL PORT

Several configurations can be designed for the serial port on the OEM hardware, but the most common are:

- RS232 PC com port
- microcontroller UART @ 1.8V (Universal Asynchronous Receive Transmit)
- microcontroller UART @ 3V or other voltages different from 1.8V
- microcontroller UART @ 5V or other voltages different from 1.8V

Depending from the type of serial port on the OEM hardware a level translator circuit may be needed to make the system work. The only configuration that doesn't need a level translation is the 1.8V UART.

The serial port on the GL865-DUAL/QUAD V3 is a +1.8V UART with all the 8 RS232 signals. It differs from the PC-RS232 in the signal polarity (RS232 is reversed) and levels. The levels for the GL865-DUAL/QUAD V3 UART are the CMOS levels:

#### Absolute Maximum Ratings -Not Functional

Parameter	Min	Max
Input level on any digital pad when on	-0.3V	+2.1V
Input voltage on analog pads when on	-0.3V	+2.1V

#### Operating Range - Interface levels (1.8V CMOS)

Level	Min	Max
Input high level $V_{IH}$	1.5V	1.9V
Input low level $V_{IL}$	0V	0.35V
Output high level $V_{OH}$	1.6V	1.9V
Output low level $V_{OL}$	0V	0.2V



The signals of the GL865-DUAL/QUAD V3 serial port are:

RS232 Pin Number	Signal	GL865-DUAL/QUAD V3 Pad Number	Name	Usage
1	DCD - dcd_uart	1	Data Carrier Detect	Output from the GL865-DUAL/QUAD V3 that indicates the carrier presence
2	RXD - tx_uart	8	Transmit line *see Note	Output transmit line of GL865-DUAL/QUAD V3 UART
3	TXD - rx_uart	7	Receive line *see Note	Input receive of the GL865-DUAL/QUAD V3 UART
4	DTR - dtr_uart	4	Data Terminal Ready	Input to the GL865-DUAL/QUAD V3 that controls the DTE READY condition
5	GND	32, 33, 35, 36, 46	Ground	Ground
6	DSR - dsr_uart	3	Data Set Ready	Output from the GL865-DUAL/QUAD V3 that indicates the module is ready
7	RTS -rts_uart	5	Request to Send	Input to the GL865-DUAL/QUAD V3 that controls the Hardware flow control
8	CTS - cts_uart	6	Clear to Send	Output from the GL865-DUAL/QUAD V3 that controls the Hardware flow control
9	RI - ri_uart	2	Ring Indicator	Output from the GL865-DUAL/QUAD V3 that indicates the incoming call condition



**NOTE:**

According to V.24, RX/TX signal names are referred to the application side, therefore on the GL865-DUAL/QUAD V3 side these signal are on the opposite direction: TXD on the application side will be connected to the receive line (here named TXD/ rx\_uart ) of the GL865-DUAL/QUAD V3 serial port and vice versa for RX.



**NOTE:**

For a minimum implementation, only the TXD and RXD lines can be connected, the other lines can be left open provided a software flow control is implemented.



**NOTE:**

In order to avoid a back powering effect it is recommended to avoid having any HIGH logic level signal applied to the digital pins of the GL865-DUAL/QUAD V3 when the module is powered off or during an ON/OFF transition.



## 9.2. RS232 level translation

In order to interface the GL865-DUAL/QUAD V3 with a PC com port or a RS232 (EIA/TIA-232) application a level translator is required. This level translator must:

- invert the electrical signal in both directions;
- change the level from 0/1.8V to +15/-15V

Actually, the RS232 UART 16450, 16550, 16650 & 16750 chipsets accept signals with lower levels on the RS232 side (EIA/TIA-562), allowing a lower voltage-multiplying ratio on the level translator. Note that the negative signal voltage must be less than 0V and hence some sort of level translation is always required.

The simplest way to translate the levels and invert the signal is by using a single chip level translator. There are a multitude of them, differing in the number of drivers and receivers and in the levels (be sure to get a true RS232 level translator not a RS485 or other standards).

By convention the driver is the level translator from the 0-1.8V UART to the RS232 level. The receiver is the translator from the RS232 level to 0-1.8V UART.

In order to translate the whole set of control lines of the UART you will need:

- 5 drivers
- 3 receivers



---

### NOTE:

The digital input lines working at 1.8V CMOS have an absolute maximum input voltage of 2.1V; therefore the level translator IC shall not be powered by the +3.8V supply of the module. Instead, it must be powered from a +1.8V (dedicated) power supply.

---





An example of RS232 level adaptation circuitry could be done using a MAXIM transceiver (MAX218).

In this case the chipset is capable to translate directly from 0/1.8V to the RS232 levels (Example done on 4 signals only).

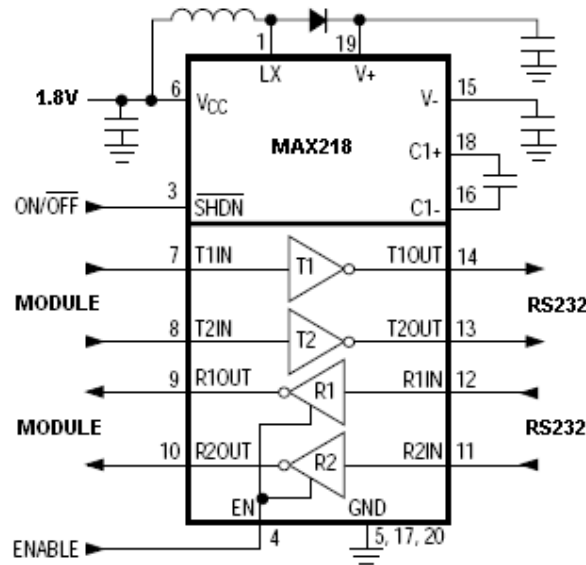

The RS232 serial port lines are usually connected to a DB9 connector with the following layout:

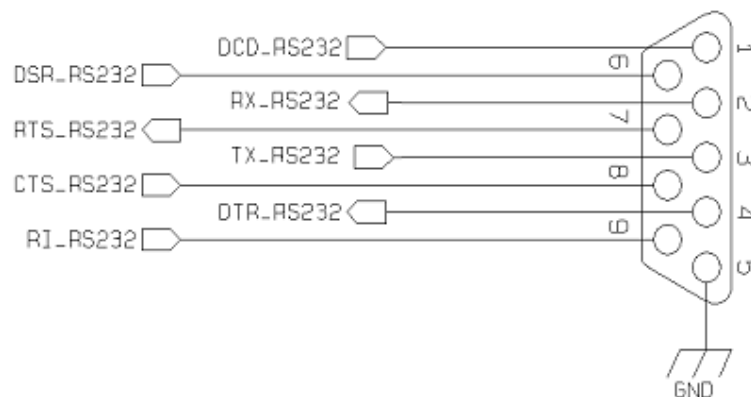

## 10. Audio Section Overview

The Base Band Chip of the GL865-DUAL/QUAD V3 provides one input for audio to be transmitted (*Uplink*) that can be connected directly to a microphone or an audio source. The bias for the microphone is already provided by the product; so the connection can be done in both following ways:

### 10.1. MIC connection

The first connection (referred to as single ended) is preferable, since the residual  $V_{mic}$  noise is fed into the input as common mode and therefore rejected, while the ground noise is blocked by the high impedance of the microphone (electret mike is a current signal source). In this situation we have to recall that the microphone is a sound to current transducer, so the resistor turns the current into voltage and acts as a voltage source; finally the resistor feeds the input in balanced way even if the configuration, from a microphone point of view, seems to be un-balanced.

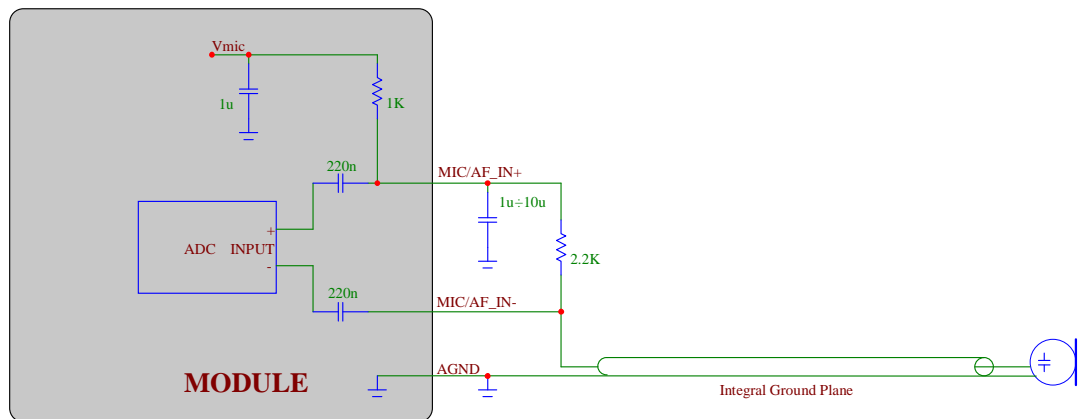

If a "balanced way" is anyway desired, much more care has to be taken to  $V_{mic}$  noise and ground noise; also the 33pF-100Ohm-33pF RF-filter has to be doubled (one each wire).



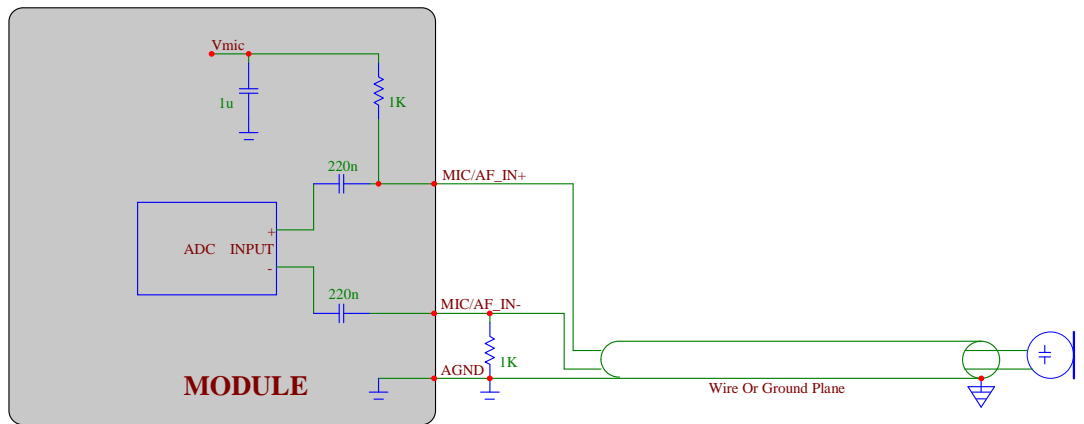

**TIP:** Since the J-FET transistor inside the microphone acts as RF-detector-amplifier, ask vendor for a microphone with anti-EMI capacitor (usually a 33pF or a 10pF capacitor placed across the output terminals inside the case).

## 10.2. LINE-IN connection

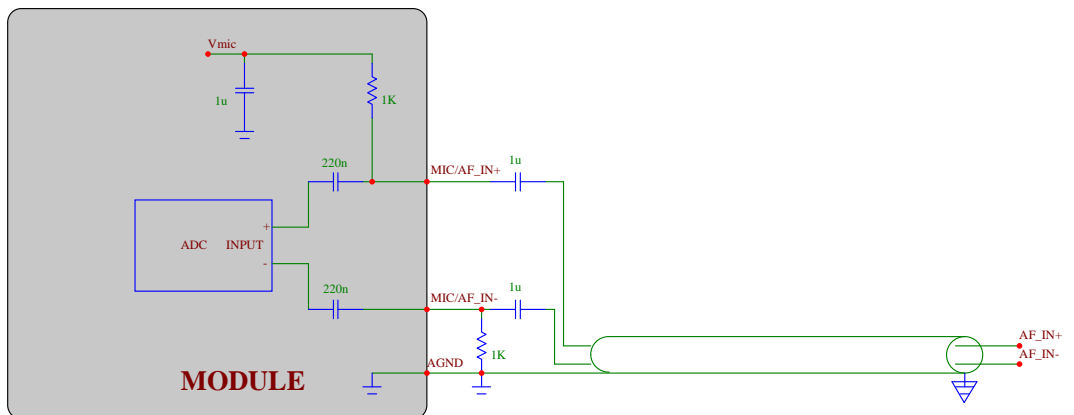

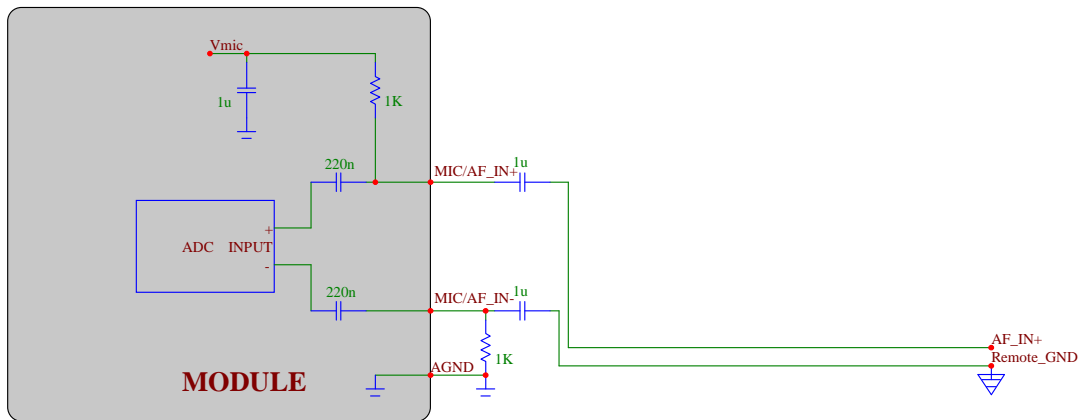

If the audio source is not a mike but a different device, the following connections can be done. Place a 1Kohm resistor to ground on the negative input, in order to get balanced the input; than connect the source via 1uF capacitor, so the DC current is blocked. Since the input is differential, the common mode voltage noise between the two (different) grounds is rejected, provided that both AF\_IN+ & AF\_IN- are connected directly onto the source.



### 10.3. EAR connection

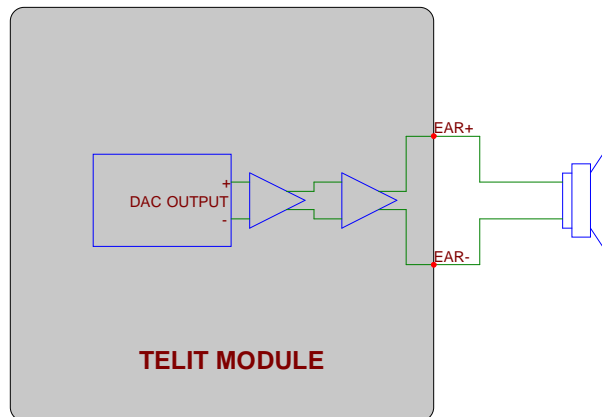

The audio output of the GL865-DUAL/QUAD V3 is balanced, this is helpful to double the level and to reject common mode (click and pop are common mode and therefore rejected); furthermore the output stage is class-D, so it can manage directly a loudspeaker with electrical impedance of at least 8Ohm. This stage is powered by switching from V<sub>batt</sub> to gnd at a frequency ranging from 0.6 to 2MHz, so it has a good efficiency and thus a big power budget 0.7W; being a class-D architecture, please use some caution (see the NOTE below).



---

**NOTE:**

When the loudspeaker is connected with a long cable, an L-C filter is recommended.  
When the EAR+/- are feeding some electronic circuitry, an R-C filter is recommended.

---



**TIP:** in order to get the maximum audio level at a given output voltage level (dBspl/Vrms), the following breaking through procedure can be used. Have the loudspeaker as close as you can to the listener (this simplify also the echo cancelling); choose the loudspeaker with the higher sensitivity (dBspl per W); choose loudspeakers with the impedance close to the limit (ex: 16 or 8 Ohm), in order to feed more power inside the transducer (it increases the W/Vrms ratio). If this were not enough, an external amplifier should be used.

---



---

**WARNING:**

The audio output hardware of the GL865-DUAL/QUAD V3 is based on a Class-D amplifier so any singled-end output configuration **MUST NOT BE USED**, otherwise the presence of GSM buzzing and low level audio performance will result.

---



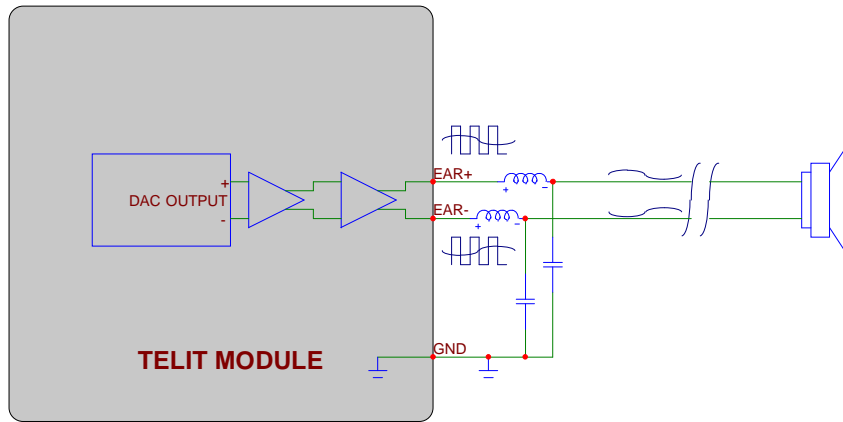

L-C filtering for LOW impedance load.

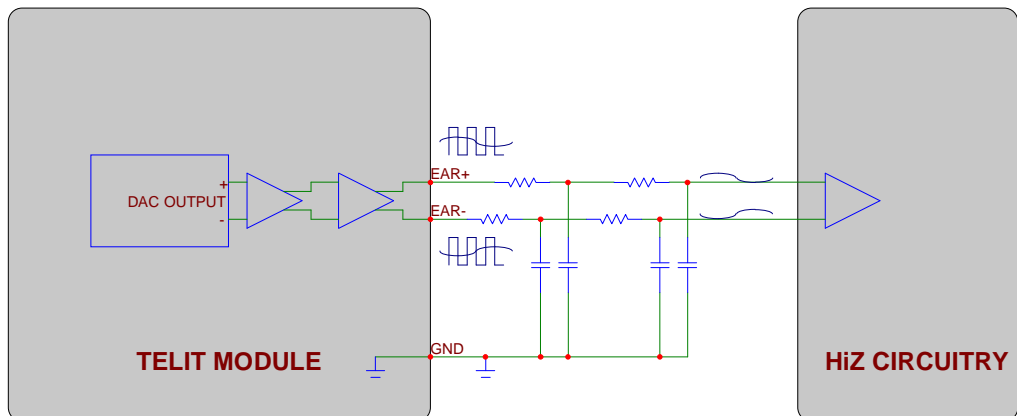

R-C filtering for HIGH impedance load.



## 10.4. Electrical Characteristics

### 10.4.1. Input Lines

Microphone/Line-in path	
Line Type	Differential
Coupling capacitor	$\geq 100\text{nF}$
Differential input resistance	$50\text{k}\Omega$
Levels	
To have 0 dBfs @ 1KHz (*)	Differential input voltage
MIC Gain = 0dB	290mVrms
MIC Gain = +6dB	145mVrms
MIC Gain = +12dB	72mVrms
MIC Gain = +18dB	36mVrms
MIC Gain = +24dB	18mVrms
MIC Gain = +30dB	9mVrms
MIC Gain = +36dB	4.5mVrms
MIC Gain = +42dB	2.25mVrms

(\*) 0 dBfs in the network are +3.14 dBm0



**TIP:** The Electret microphone is internally amplified by a J-Fet transistor, thus the sound is carried out as saturation drain current; this means that the Norton equivalence has to be considered. The signal is converted to voltage on the 2.2KOhm resistance, from there on circuitry has to be routed in order to not pick up common mode noise; beware of the return path (ground).



### 10.4.2. Output Lines

EAR/Line-out Output	
Differential line coupling	Direct connection ( $V_{DC}=1.7\div 2.1V$ )
output load resistance	$\geq 8 \Omega$
signal bandwidth	250-3400Hz (@ -3dB with default filter)
max. differential output voltage	1120 mV <sub>pp</sub> @3.14dBm0 (*)
differential output voltage	550mV <sub>rms</sub> @0dBm0 (*)
volume increment	2dB per step
volume steps	0..10

(\*) in default condition: Output Volume = +20dB, Output Attenuation = 0dB



**TIP:** We suggest driving the load differentially; this kills all the common mode noises (click and pop, for example), the output swing will double (+6dB) and the big output coupling capacitor will be avoided.

In order to get the maximum power output from the device, the resistance of the tracks has to be negligible in comparison to the load.





## 11. General Purpose I/O

The general purpose I/O pads can be configured to act in three different ways:

- input
- output
- alternate function (*internally controlled*)

*Input pads* can be read; they report the digital value (*high or low*) present on the pad at the read time .

*Output pads* can only be written or queried and set the value of the pad output.

An *alternate function pad* is internally controlled by the GL865-DUAL/QUAD V3 firmware and acts depending on the function implemented.

For Logic levels please refer to chapter 8.

The following table shows the available GPIO on the GL865-DUAL/QUAD V3.

Pin	Signal	I/O	Function	Type	Input / output current	Default State	ON_OFF state	State during Reset	Note
42	GPIO_01	I/O	Configurable GPIO	CMOS 1.8V	1uA/1mA	INPUT	0	0	Alternate function DVI_WA0
41	GPIO_02	I/O	Configurable GPIO	CMOS 1.8V	1uA/1mA	INPUT	0	0	Alternate function JDR and DVI_RX
40	GPIO_03	I/O	Configurable GPIO	CMOS 1.8V	1uA/1mA	INPUT	0	0	Alternate function DVI_TX
39	GPIO_04	I/O	Configurable GPIO	CMOS 1.8V	1uA/1mA	INPUT	0	0	Alternate function TX Disable and DVI_TX
29	GPIO_05	I/O	Configurable GPIO	CMOS 1.8V	1uA/1mA	INPUT	0	0	Alternate function RFTXMON
28	GPIO_06	I/O	Configurable GPIO	CMOS 1.8V	1uA/1mA	INPUT	0	0	Alternate function ALARM
27	GPIO_07	I/O	Configurable GPIO	CMOS 1.8V	1uA/1mA	INPUT	0	0	Alternate function BUZZER
26	GPIO_08	I/O	Configurable GPIO	CMOS 1.8V	1uA/1mA	INPUT	0	0	Alternate function STAT_LED



### WARNING:

During power up the GPIOs may be subject to transient glitches.



Also the UART's control flow pins can be usable as GPI/O.

Pin	Signal	I/O	Function	Type	Input / output current	Default State	ON_OFF state	State during Reset	Note
1	GPO_A	O	Configurable GPO	CMOS 1.8V	1uA/1mA	INPUT	0	0	Alternate function C109/DCD
2	GPO_B	O	Configurable GPO	CMOS 1.8V	1uA/1mA	INPUT	0	0	Alternate function C125/RING
3	GPO_C	O	Configurable GPO	CMOS 1.8V	1uA/1mA	INPUT	0	0	Alternate function C107/DSR
4	GPI_E	I	Configurable GPI	CMOS 1.8V	1uA/1mA	INPUT	0	0	Alternate function C108/DTR
5	GPI_F	I	Configurable GPI	CMOS 1.8V	1uA/1mA	INPUT	0	0	Alternate function C105/RTS
6	GPO_D	O	Configurable GPO	CMOS 1.8V	1uA/1mA	INPUT	0	0	Alternate function C106/CTS

## 11.1. GPIO Logic levels

Where not specifically stated, all the interface circuits work at 1.8V CMOS logic levels. The following table shows the logic level specifications used in the GL865-DUAL/QUAD V3 interface circuits:

### Absolute Maximum Ratings -Not Functional

Parameter	Min	Max
Input level on any digital pin (CMOS 1.8) when on	-0.3V	+2.1V

### Operating Range - Interface levels (1.8V CMOS)

Level	Min	Max
Input high level	1.5V	1.9V
Input low level	0V	0.35V
Output high level	1.6V	1.9V
Output low level	0V	0.2V

### Current characteristics

Level	Typical
Output Current	1mA
Input Current	1uA



## 11.2. Using a GPIO Pad as INPUT

The GPIO pads, when used as inputs, can be connected to a digital output of another device and report its status, provided this device has interface levels compatible with the 1.8V CMOS levels of the GPIO.

If the digital output of the device to be connected with the GPIO input pad has interface levels different from the 1.8V CMOS, then it can be buffered with an open collector transistor with a 47K pull up to 1.8V.



### NOTE:

In order to avoid a back powering effect it is recommended to avoid having any HIGH logic level signal applied to the digital pins of the GL865-DUAL/QUAD V3 when the module is powered OFF or during an ON/OFF transition.



### TIP:

The V\_AUX / PWRMON pin can be used for input pull up reference or/and for ON monitoring.

## 11.3. Using a GPIO Pad as OUTPUT

The GPIO pads, when used as outputs, can drive 1.8V CMOS digital devices or compatible hardware. When set as outputs, the pads have a push-pull output and therefore the pull-up resistor may be omitted.

## 11.4. Using the RF Transmission Control GPIO4

The GPIO4 pin, when configured as RF Transmission Control Input, permits to disable the Transmitter when the GPIO is set to Low by the application.

In the design is necessary to add a resistor 47K pull up to 2.8V, this pull up must be switched off when the module is in off condition.

## 11.5. Using the RFTXMON Output GPIO5

The GPIO5 pin, when configured as RFTXMON Output, is controlled by the GL865-DUAL/QUAD V3 module and will rise when the transmitter is active and fall after the transmitter activity is completed.

There are 2 different modes for this function:

### 1) Active during all the Call:

For example, if a call is started, the line will be HIGH during all the conversation and it will be again LOW after hanged up.

The line rises up 300ms before first TX burst and will became again LOW from 500ms to 1s after last TX burst.



**2) Active during all the TX activity:**

The GPIO is following the TX bursts

Please refer to the AT User interface manual for additional information on how to enable this function.

## 11.6. Using the Alarm Output GPIO6

The GPIO6 pad, when configured as Alarm Output, is controlled by the GL865-DUAL/QUAD V3 module and will rise when the alarm starts and fall after the issue of a dedicated AT command.

This output can be used to controlling microcontroller or application at the alarm time.

## 11.7. Using the Buzzer Output GPIO7

The GPIO7 pad, when configured as Buzzer Output, is controlled by the GL865-DUAL/QUAD V3 module and will drive a Buzzer driver with appropriate square waves.

This permits to your application to easily implement Buzzer feature with ringing tones or melody played at the call incoming, tone playing on SMS incoming or simply playing a tone or melody when needed.

A sample interface scheme is included below to give you an idea of how to interface a Buzzer to the GPIO7:

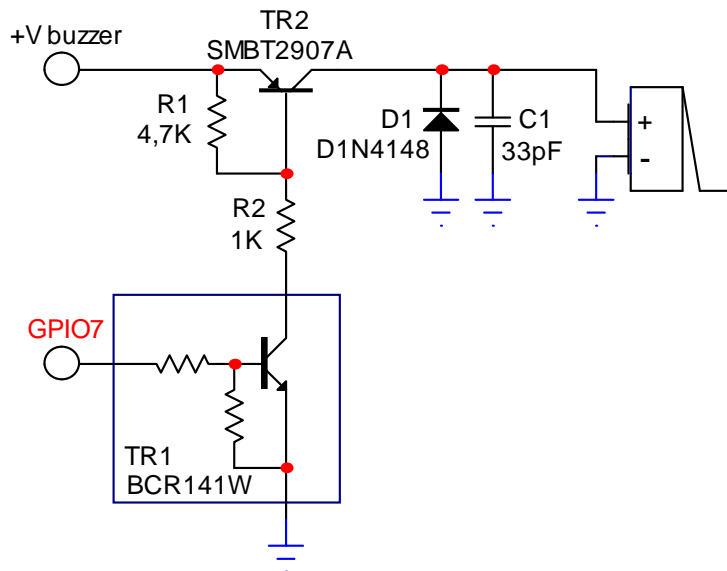

**NOTE:**

To correctly drive a buzzer a driver must be provided, its characteristics depend on the Buzzer and for them refer to your buzzer vendor.



## 11.8. Magnetic Buzzer Concepts

### 11.8.1. Short Description

A magnetic Buzzer is a sound-generating device with a coil located in the magnetic circuit consisting of a permanent magnet, an iron core, a high permeable metal disk and a vibrating diaphragm.

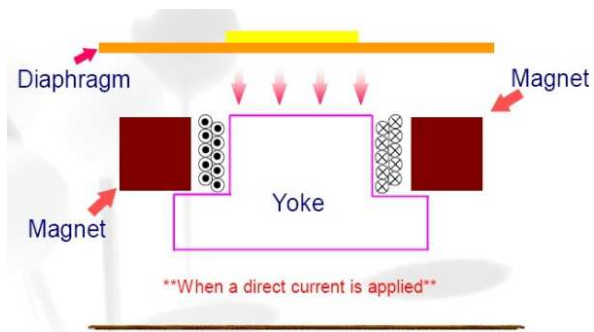

Drawing of the Magnetic Buzzer.

The disk and diaphragm are attracted to the core by the magnetic field. When an oscillating signal is moved through the coil, it produces a fluctuating magnetic field which vibrates the diaphragm at the frequency of the drive signal. Thus the sound is produced relative to the frequency applied.

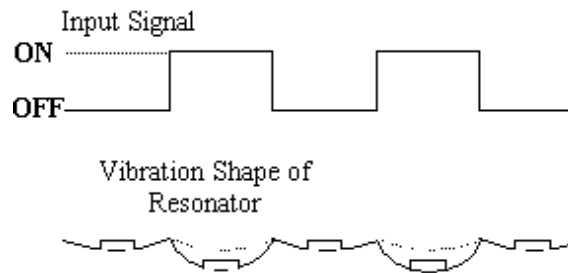

Diaphragm movement.



### 11.8.2. Frequency Behavior

The frequency behavior represents the effectiveness of the reproduction of the applied signals. Because performance is related to a square driving waveform (whose amplitude varies from 0V to  $V_{pp}$ ), if you modify the waveform (e.g. from square to sinus) the frequency response will change.

### 11.8.3. Power Supply Influence

Applying a signal whose amplitude is different from that suggested by the manufacturer, the performance change following the rule “if resonance frequency  $f_o$  increases, amplitude decreases”.

Because resonance frequency depends on acoustic design, by lowering the amplitude of the driving signal the response bandwidth tends to become narrow, and vice versa.

Summarizing:  $V_{pp} \uparrow \rightarrow f_o \downarrow$      $V_{pp} \downarrow \rightarrow f_o \uparrow$

The risk is that the  $f_o$  could easily fall outside of new bandwidth; consequently the SPL could be much lower than the expected.



**WARNING:**

It is very important to respect the sense of the applied voltage: never apply to the “-” pin a voltage more positive than the “+” pin: if this happens, the diaphragm vibrates in the opposite direction with a high probability to be expelled from its physical position. This damages the device permanently.

### 11.8.4. Working Current Influence

In the component data sheet you will find the value of MAX CURRENT: this represents the maximum average current that can flow at nominal voltage without current limitation. In other words it is not the peak current, which could be twice or three times higher. If driving circuitry does not support these peak values, the SPL will never reach the declared level or the oscillations will stop.



## 11.9. STAT LED Indication of network service availability

The STAT\_LED pin status shows information on the network service availability and Call status.

In the GL865-DUAL/QUAD V3 modules, the STAT\_LED usually needs an external transistor to drive an external LED.

Therefore, the status indicated in the following table is reversed with respect to the pin status.

LED status	Device Status
Permanently off	Device off
Fast blinking (Period 1s, Ton 0,5s)	Net search / Not registered / turning off
Slow blinking (Period 3s, Ton 0,3s)	Registered full service
Permanently on	a call is active

A schematic example could be:

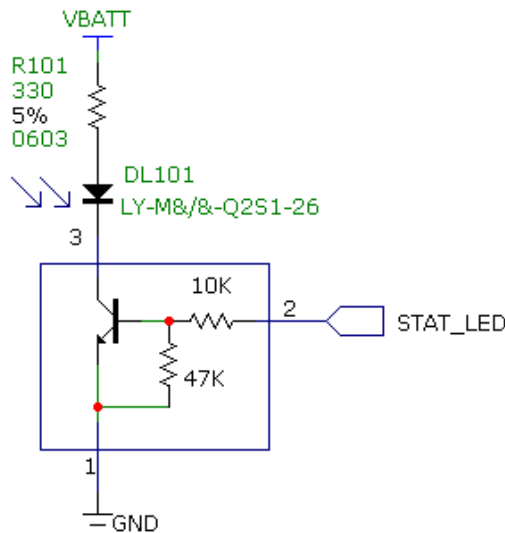

## 11.10. SIMIN detect function

All the GPIO pins can be used as SIM DETECT input. The AT Command used to enable the function is:

**AT#SIMINCFG**

Use the AT command **AT#SIMDET=2** to enable the SIMIN detection

Use the AT command **AT+W0** and **AT+P0** to store the SIMIN detection **in the common profile.**

For full details see AT Commands Reference Guide, 80000ST10025a.



---

### NOTE:

Don't use the SIM IN function on the same pin where the GPIO function is enabled and vice versa!

---

## 11.11. RTC Bypass out

The VRTC pin brings out the Real Time Clock supply, which is separate from the rest of the digital part, allowing having only RTC going on when all the other parts of the device are off. To this power output a backup battery can be added in order to increase the RTC autonomy during power off of the main battery (power supply). NO Devices must be powered from this pin.

## 11.12. SIM Holder Implementation

Please refer to the related User Guide (SIM Holder Design Guides, 80000NT10001a).





## 12. DAC and ADC section

### 12.1. DAC Converter

#### 12.1.1. Description

The GL865-DUAL/QUAD V3 provides a Digital to Analog Converter. The signal (named DAC\_OUT) is available on pin **15** of the GL865-DUAL/QUAD V3.

The on board DAC is a 10 bit converter, able to generate an analogue value based on a specific input in the range from 0 up to 1023. However, an external low-pass filter is necessary

	Min	Max	Units
Voltage range (filtered)	0	1.8	Volt
Range	0	1023	Steps

The precision is 10 bits so, if we consider that the maximum voltage is 2V, the integrated voltage could be calculated with the following formula:

$$\text{Integrated output voltage} = (2 * \text{value}) / 1023$$

DAC\_OUT line must be integrated (for example with a low band pass filter) in order to obtain an analog voltage.



## 12.1.2. Enabling DAC

An *AT command* is available to use the DAC function.  
The command is: **AT#DAC= [<enable> [, <value>]]**

<value> - scale factor of the integrated output voltage (0..1023 - 10 bit precision)  
it must be present if <enable>=1

Refer to SW User Guide or AT Commands Reference Guide for the full description of this function.



### NOTE:

The DAC frequency is selected internally. D/A converter must not be used during POWERSAVING.

## 12.1.3. Low Pass Filter Example

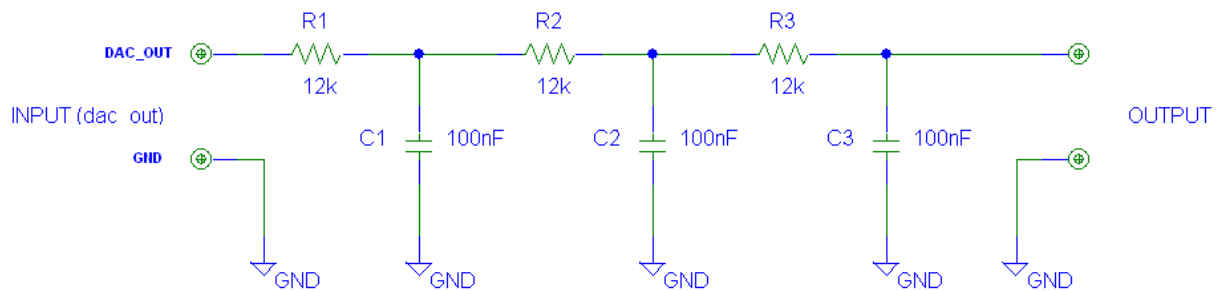

## 12.2. ADC Converter

### 12.2.1. Description

The on board A/D converters are 11-bit converters. They are able to read a voltage level in the range of 0÷2 volts applied on the ADC pin input, store and convert it into 11 bit word.

	Min	Max	Units
Input Voltage range	0	1.2	Volt
AD conversion	-	10	bits
Resolution	-	> 1	mV

The GL865-DUAL/QUAD V3 module provides 2 Analog to Digital Converters.  
The input lines are:

ADC\_IN1  
available on pin 13

ADC\_IN2  
available on pin 14

### 12.2.2. Using ADC Converter

An AT command is available to use the ADC function.

The command is *AT#ADC=1,2*

The read value is expressed in mV

Refer to SW User Guide or AT Commands Reference Guide for the full description of this function.



## 13. Mounting the GL865-DUAL/QUAD V3 on your Board

### 13.1. General

The GL865-DUAL/QUAD V3 modules have been designed to be compliant with a standard lead-free SMT process.

### 13.2. Module finishing & dimensions

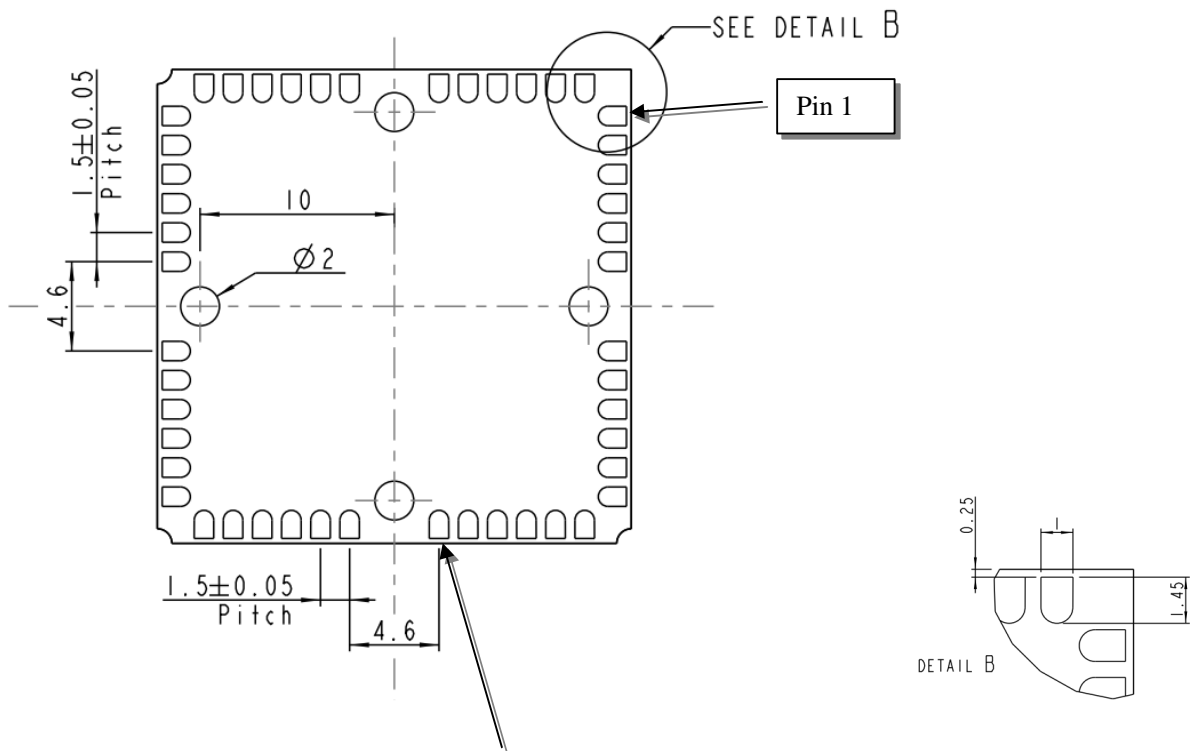

**Lead-free Alloy:**  
Surface finishing Ni/Au for all solder pads

**Bottom View**

**Dimensions in mm**



### 13.3. Recommended foot print for the application

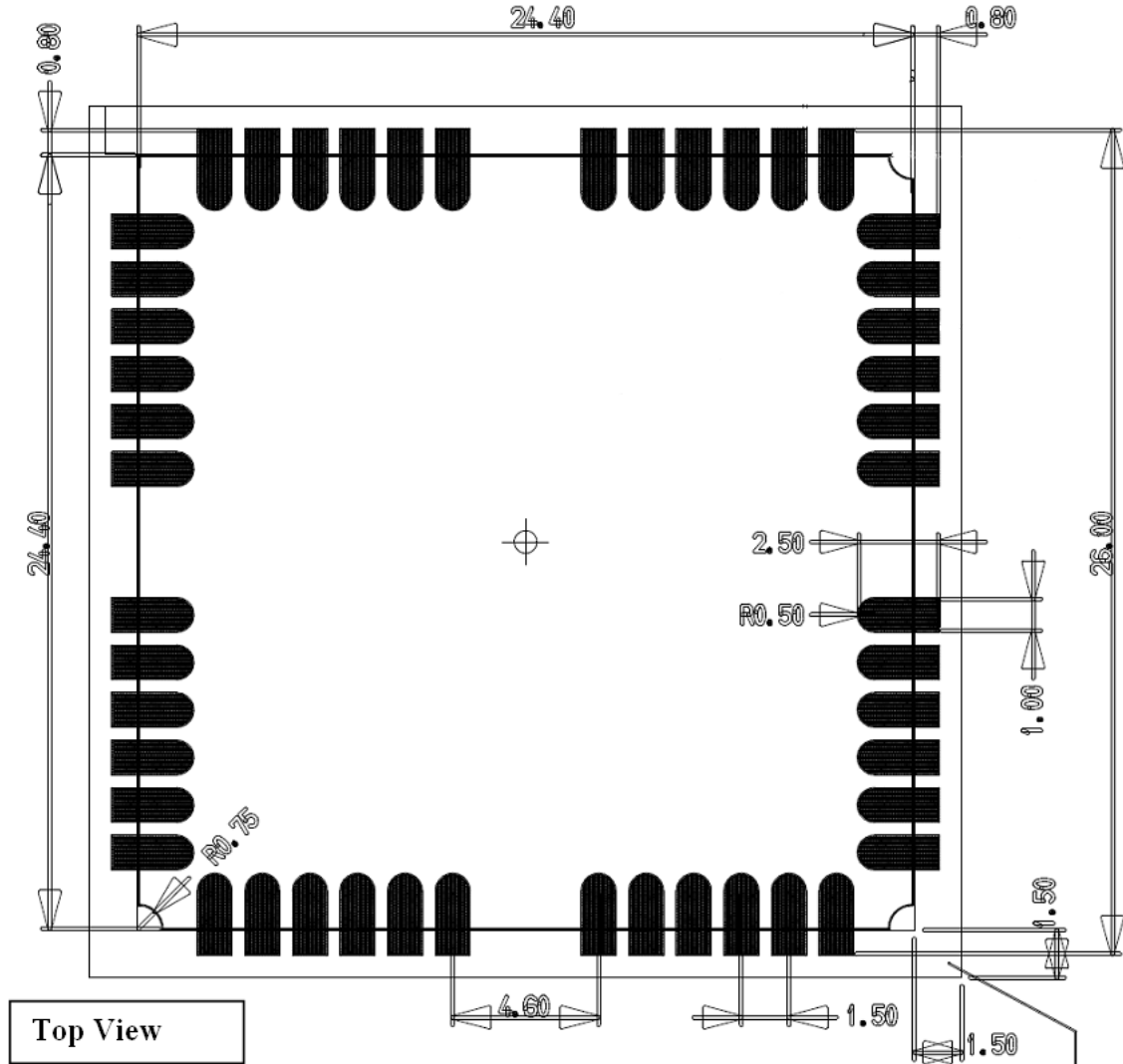

In order to easily rework the GL865-DUAL/QUAD V3 is suggested to consider on the application a 1.5 mm placement inhibited area around the module.

It is also suggested, as common rule for an SMT component, to avoid having a mechanical part of the application in direct contact with the module.

### 13.4. Stencil

Stencil's apertures layout can be the same of the recommended footprint (1:1), we suggest a thickness of stencil foil  $\geq 120\mu\text{m}$ .



### 13.5. PCB pad design

Non solder mask defined (NSMD) type is recommended for the solder pads on the PCB.

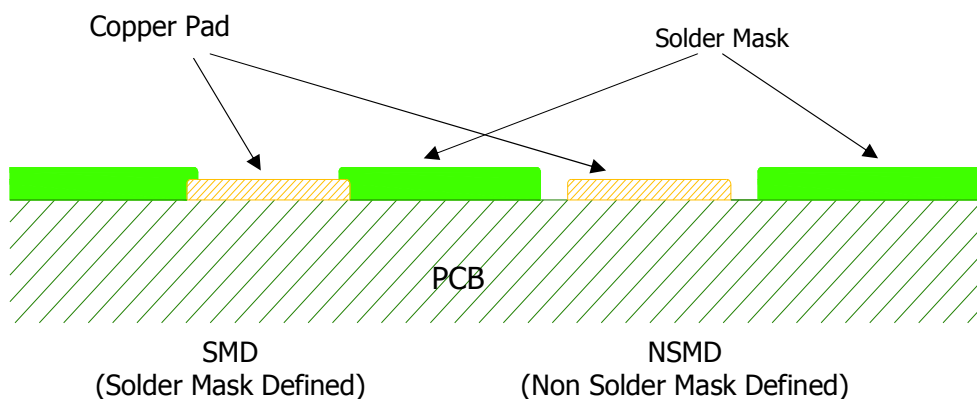

### 13.6. Recommendations for PCB pad dimensions (mm):

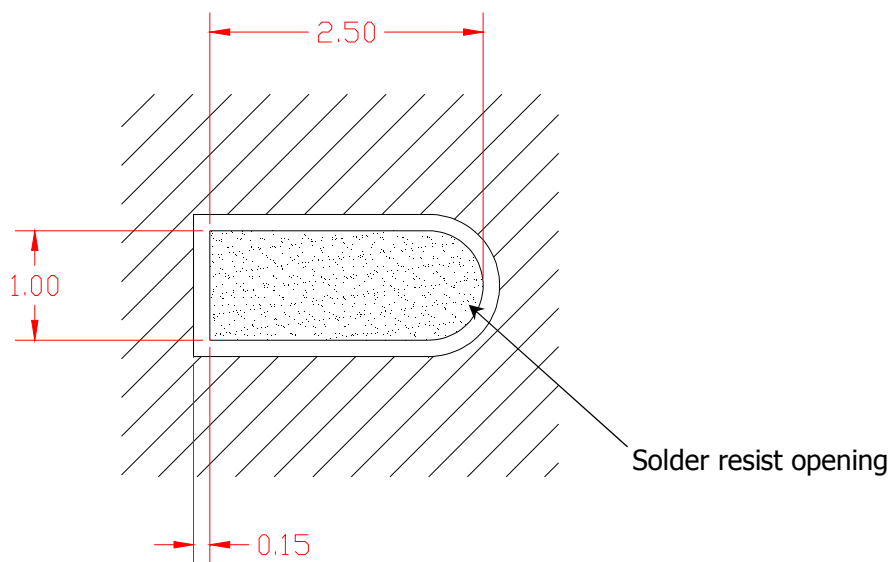

It is not recommended to place via or micro-via not covered by solder resist in an area of 0.3 mm around the pads unless it carries the same signal of the pad itself (see following figure).



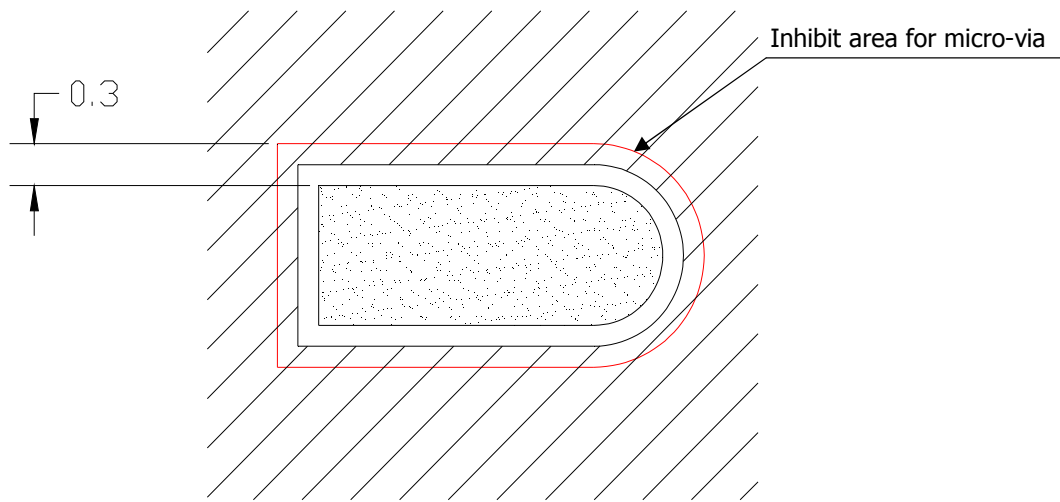

Holes in pad are allowed only for blind holes and not for through holes.

Recommendations for PCB pad surfaces:

Finish	Layer thickness [ $\mu\text{m}$ ]	Properties
Electro-less Ni / Immersion Au	3 -7 / 0.05 - 0.15	good solder ability protection, high shear force values

The PCB must be able to resist the higher temperatures which are occurring at the lead-free process. This issue should be discussed with the PCB-supplier. Generally, the wettability of tin-lead solder paste on the described surface plating is better compared to lead-free solder paste.

It is not necessary to panel the application PCB, however in that case it is suggested to use milled contours and predrilled board breakouts; scoring or v-cut solutions are not recommended.



### 13.7. Solder paste

	Lead free
Solder paste	Sn/Ag/Cu

We recommend using only “no clean” solder paste in order to avoid the cleaning of the modules after assembly.

### 13.8. GL865-DUAL/QUAD V3 Solder reflow

Recommended solder reflow profile

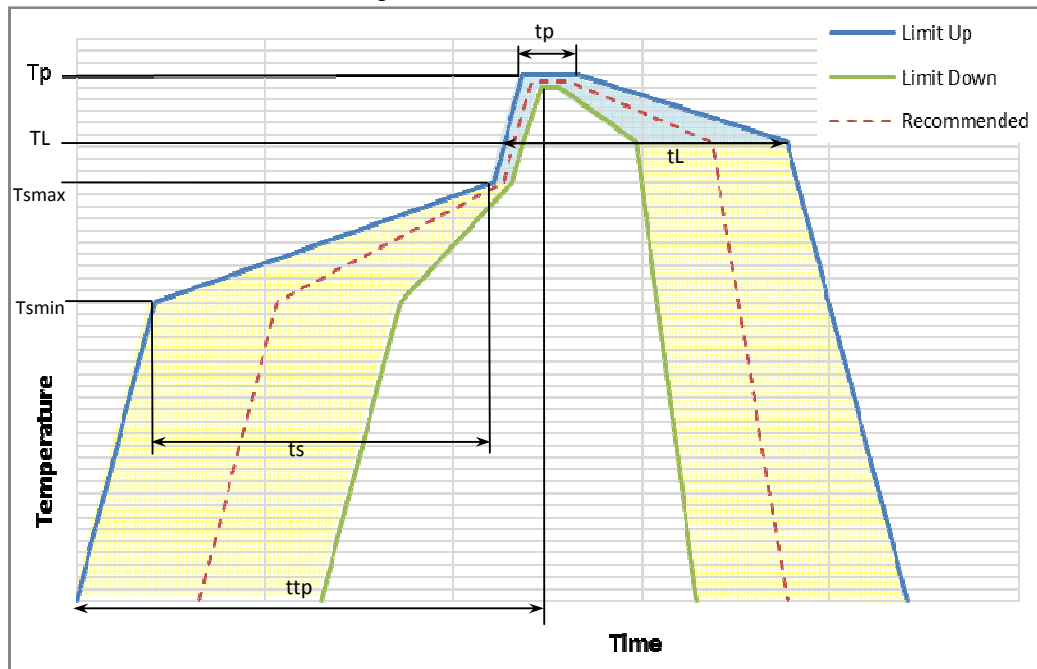



Profile Feature	Pb-Free Assembly
Average ramp-up rate (TL to TP)	3°C/second max
Preheat	
– Temperature Min (T <sub>min</sub> )	150°C
– Temperature Max (T <sub>max</sub> )	200°C
– Time (min to max) (ts)	60-180 seconds
T <sub>max</sub> to TL	
– Ramp-up Rate	3°C/second max
Time maintained above:	
– Temperature (TL)	217°C
– Time (tL)	60-150 seconds
Peak Temperature (T <sub>p</sub> )	245 +0/-5°C
Time within 5°C of actual Peak Temperature (t <sub>p</sub> )	10-30 seconds
Ramp-down Rate	6°C/second max.
Time 25°C to Peak Temperature (t <sub>tp</sub> )	8 minutes max.



**NOTE:**

All temperatures refer to topside of the package, measured on the package body surface



**WARNING:**

The GL865-DUAL/QUAD V3 module withstands one reflow process only.

## 13.9. Debug of the GL865-DUAL/QUAD V3 in production

To test and debug the mounting of the GL865-DUAL/QUAD V3, we strongly recommend foreseeing test pads on the host PCB, in order to check the connection between the GL865-DUAL/QUAD V3 itself and the application and to test the performance of the module connecting it with an external computer. Depending by the customer application, these pads include, but are not limited to the following signals:

- TXD
- RXD
- ON/OFF\*
- HW SHUTDOWN\*
- GND
- VBATT
- TX\_AUX
- RX\_AUX
- PWRMON



## 14. Packing system

### 14.1. Packing on tray

The GL865-DUAL/QUAD V3 modules are packaged on trays of **20** pieces each. These trays can be used in SMT processes for pick & place handling.

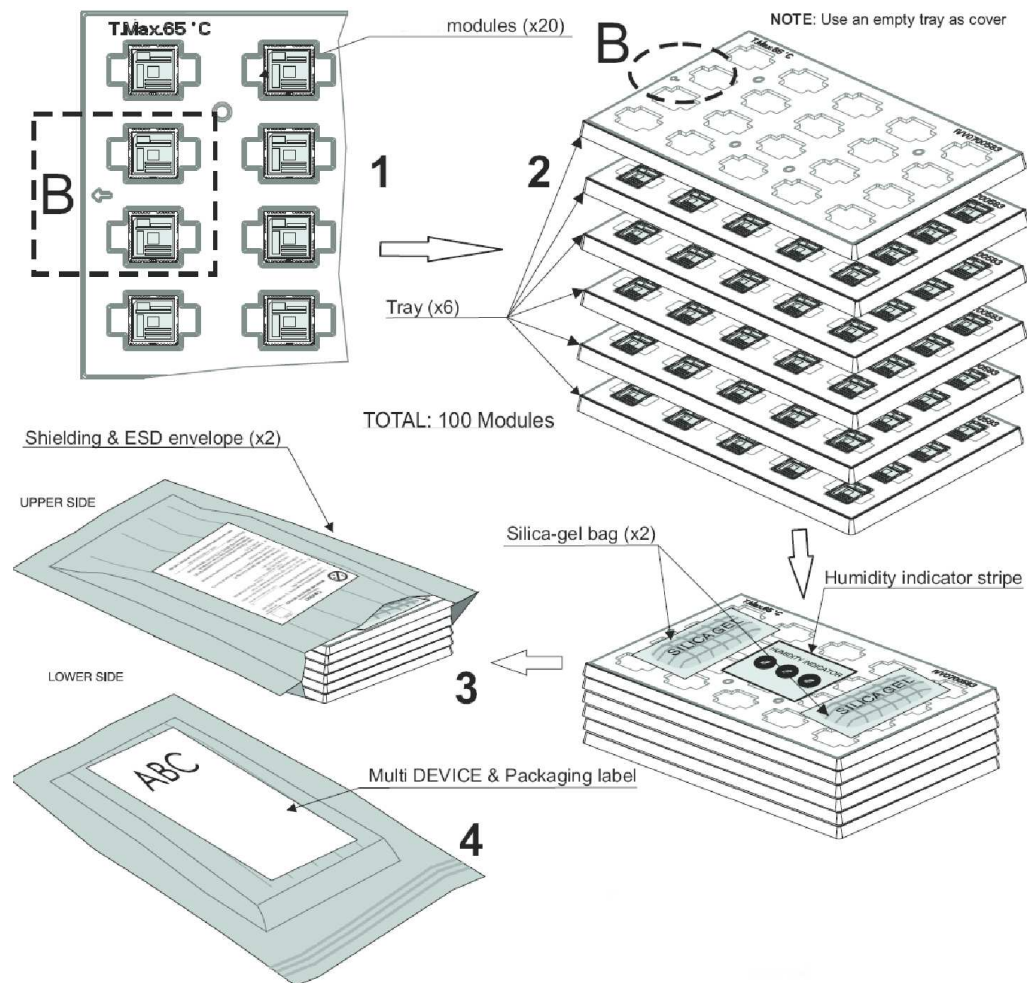

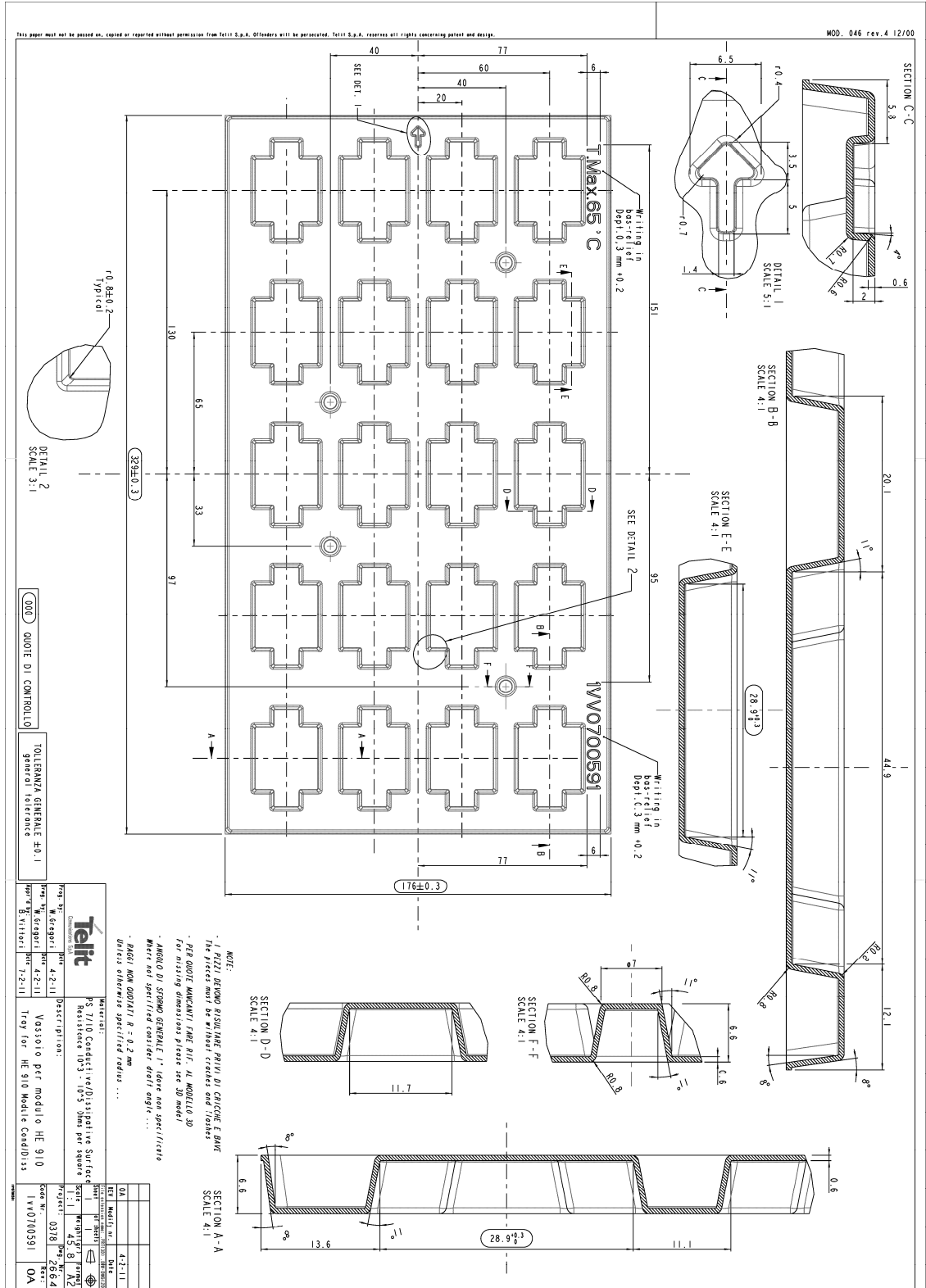

## 14.2. Packing on reel

The GL865-DUAL/QUAD V3 can be packaged on reels of **200** pieces each, see figure below.

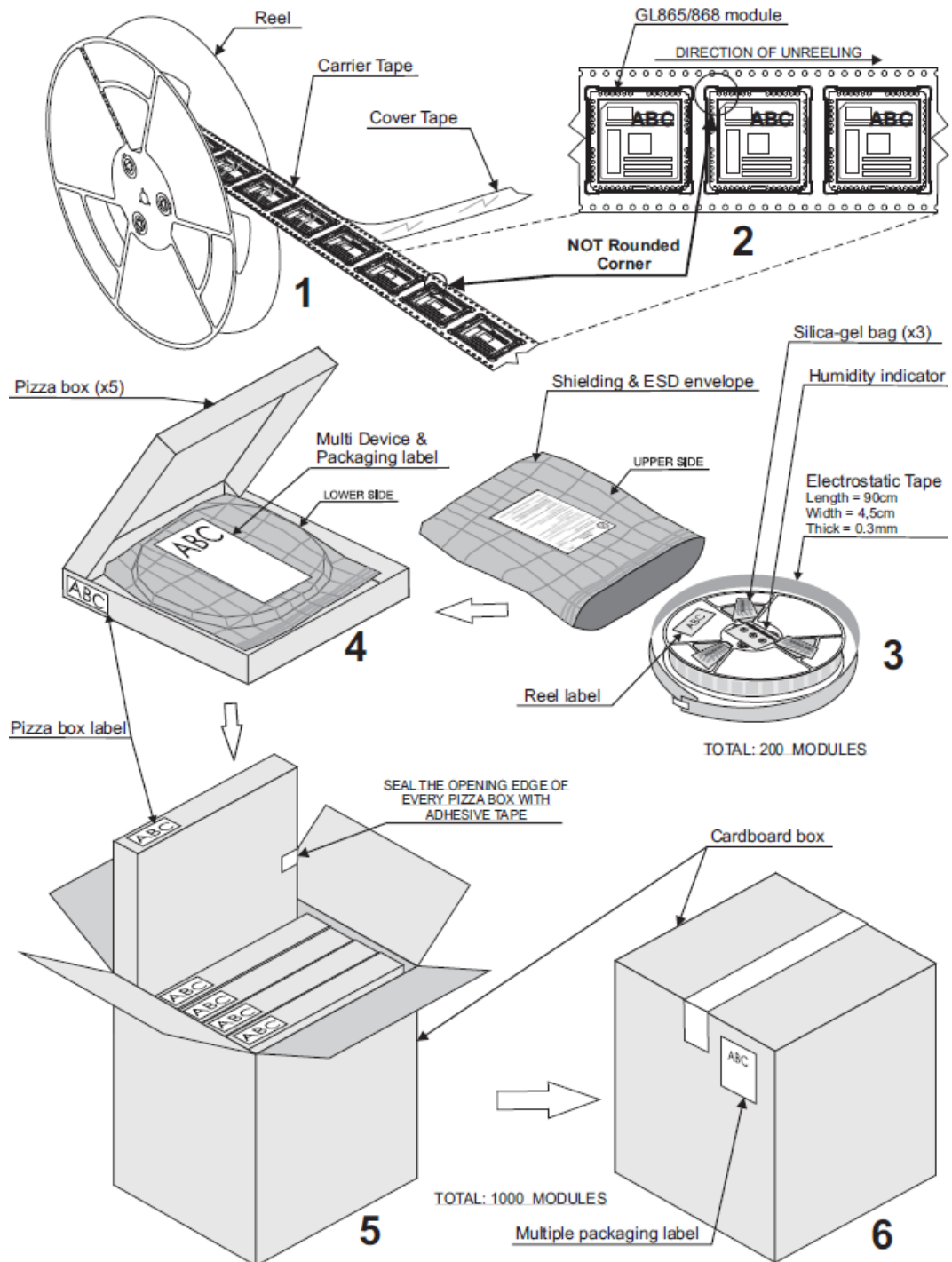

### 14.2.1. Carrier tape detail

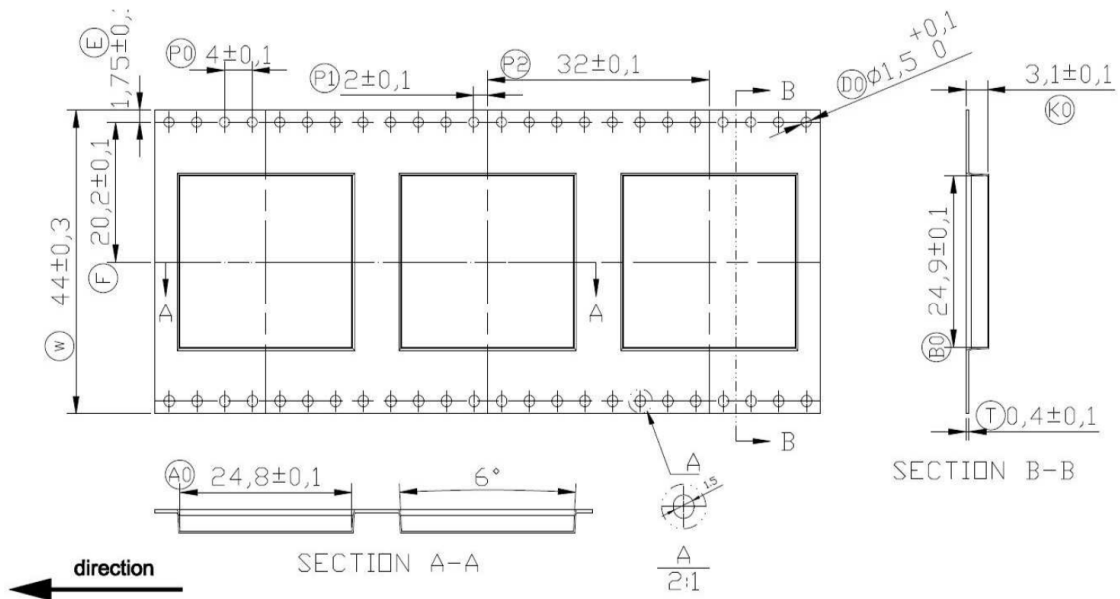

### 14.2.2. Carrier tape detail

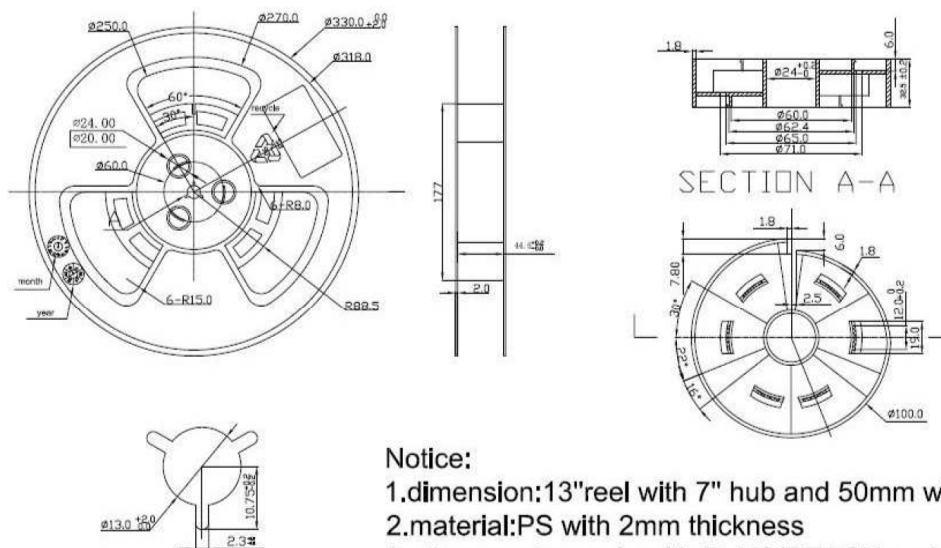

**Notice:**

- 1.dimension:13" reel with 7" hub and 50mm width
- 2.material:PS with 2mm thickness
- 3.other:must comply with RoHS/REACH and other industry standard



### 14.3. Moisture sensibility

The level of moisture sensibility of the Product is “3” according with standard IPC/JEDEC J-STD-020, take care of all the relative requirements for using this kind of components.

Moreover, the customer has to take care of the following conditions:

- a) The shelf life of the Product inside of the dry bag must be 12 months from the bag seal date, when stored in a non-condensing atmospheric environment of <math><40^{\circ}\text{C}</math> / 90% RH
- b) Environmental condition during the production:  $\leq 30^{\circ}\text{C}$  / 60% RH according to IPC/JEDEC J-STD-033A paragraph 5
- c) The maximum time between the opening of the sealed bag and the reflow process must be 168 hours if condition b) “IPC/JEDEC J-STD-033A paragraph 5.2” is respected
- d) Baking is required if conditions b) or c) are not respected
- e) Baking is required if the humidity indicator inside the bag indicates 10% RH or more



## 15. Conformity Assessment Issues

### European Union - Directive 1999/5/EC

The GL865-DUAL/QUAD V3 complies with the essential requirements of the 1999/5/EC Directive.

Bulgarian	С настоящето Telit Communications S.p.A. декларира, че Dual Band GSM/GPRS module отговаря на съществените изисквания и другите приложими изисквания на Директива 1999/5/EC.
Czech	Telit Communications S.p.A. tímto prohlašuje, že tento Dual Band GSM/GPRS module je ve shodě se základními požadavky a dalšími příslušnými ustanoveními směrnice 1999/5/ES.
Danish	Undertegnede Telit Communications S.p.A. erklærer herved, at følgende udstyr Dual Band GSM/GPRS module overholder de væsentlige krav og øvrige relevante krav i direktiv 1999/5/EF.
Dutch	Hierbij verklaart Telit Communications S.p.A. dat het toestel Dual Band GSM/GPRS module in overeenstemming is met de essentiële eisen en de andere relevante bepalingen van richtlijn 1999/5/EG.
English	Hereby, Telit Communications S.p.A., declares that this Dual Band GSM/GPRS module is in compliance with the essential requirements and other relevant provisions of Directive 1999/5/EC.
Estonian	Käesolevaga kinnitab Telit Communications S.p.A. seadme Dual Band GSM/GPRS module vastavust direktiivi 1999/5/EÜ põhinõuetele ja nimetatud direktiivist tulenevatele teistele asjakohastele sätetele.
German	Hiermit erklärt Telit Communications S.p.A., dass sich das Gerät Dual Band GSM/GPRS module in Übereinstimmung mit den grundlegenden Anforderungen und den übrigen einschlägigen Bestimmungen der Richtlinie 1999/5/EG befindet.
Greek	ΜΕ ΤΗΝ ΠΑΡΟΥΣΑ Telit Communications S.p.A. ΔΗΛΩΝΕΙ ΟΤΙ Dual Band GSM/GPRS module ΣΥΜΜΟΡΦΩΝΕΤΑΙ ΠΡΟΣ ΤΙΣ ΟΥΣΙΩΔΕΙΣ ΑΠΑΙΤΗΣΕΙΣ ΚΑΙ ΤΙΣ ΛΟΙΠΕΣ ΣΧΕΤΙΚΕΣ ΔΙΑΤΑΞΕΙΣ ΤΗΣ ΟΔΗΓΙΑΣ 1999/5/ΕΚ.
Hungarian	Alulírott, Telit Communications S.p.A. nyilatkozom, hogy a Dual Band GSM/GPRS module megfelel a vonatkozó alapvető követelményeknek és az 1999/5/EC irányelv egyéb előírásainak.
Finnish	Telit Communications S.p.A. vakuuttaa täten että Dual Band GSM/GPRS module tyyppinen laite on direktiivin 1999/5/EY oleellisten vaatimusten ja sitä koskevien direktiivin muiden ehtojen mukainen.
French	Par la présente Telit Communications S.p.A. déclare que l'appareil Dual Band GSM/GPRS module est conforme aux exigences essentielles et aux autres dispositions pertinentes de la directive 1999/5/CE.
Icelandic	Hér með lýsir Telit Communications S.p.A. yfir því að Dual Band GSM/GPRS module er í samræmi við grunnkröfur og aðrar kröfur, sem gerðar eru í tilskipun 1999/5/EC
Italian	Con la presente Telit Communications S.p.A. dichiara che questo modulo Dual Band GSM/GPRS è conforme ai requisiti essenziali ed alle altre disposizioni pertinenti stabilite dalla direttiva 1999/5/CE.



Latvian	Ar šo Telit Communications S.p.A. deklarē, ka Dual Band GSM/GPRS module atbilst Direktīvas 1999/5/EK būtiskajām prasībām un citiem ar to saistītajiem noteikumiem.
Lithuanian	Šiuo Telit Communications S.p.A. deklaruoja, kad šis Dual Band GSM/GPRS module atitinka esminius reikalavimus ir kitas 1999/5/EB Direktivos nuostatas.
Maltese	Hawnhekk, Telit Communications S.p.A., jiddikjara li dan Dual Band GSM/GPRS module jikkonforma mal-htigijiet essenzjali u ma provvedimenti oħrajn relevanti li hemm fid-Direttiva 1999/5/EC.
Norwegian	Telit Communications S.p.A. erklærer herved at utstyret Dual Band GSM/GPRS module er i samsvar med de grunnleggende krav og øvrige relevante krav i direktiv 1999/5/EF.
Polish	Niniejszym Telit Communications S.p.A. oświadcza, że Dual Band GSM/GPRS module jest zgodny z zasadniczymi wymogami oraz pozostałymi stosownymi postanowieniami Dyrektywy 1999/5/EC
Portuguese	Telit Communications S.p.A. declara que este Dual Band GSM/GPRS module está conforme com os requisitos essenciais e outras disposições da Directiva 1999/5/CE.
Slovak	Telit Communications S.p.A. týmto vyhlasuje, že Dual Band GSM/GPRS module spĺňa základné požiadavky a všetky príslušné ustanovenia Smernice 1999/5/ES.
Slovenian	Telit Communications S.p.A. izjavlja, da je ta Dual Band GSM/GPRS module v skladu z bistvenimi zahtevami in ostalimi relevantnimi določili direktive 1999/5/ES.
Spanish	Por medio de la presente Telit Communications S.p.A. declara que el Dual Band GSM/GPRS module cumple con los requisitos esenciales y cualesquiera otras disposiciones aplicables o exigibles de la Directiva 1999/5/CE.
Swedish	Härmed intygar Telit Communications S.p.A. att denna Dual Band GSM/GPRS module står i överensstämmelse med de väsentliga egenskapskrav och övriga relevanta bestämmelser som framgår av direktiv 1999/5/EG.

In order to satisfy the essential requirements of 1999/5/EC Directive, GL865-DUAL/QUAD V3 module is compliant with the following standards:

RF spectrum use (R&TTE art. 3.2)	EN 301 511 V9.0.2
EMC (R&TTE art. 3.1b)	EN 301 489-1 V1.9.2 EN 301 489-7 V1.3.1
Health & Safety (R&TTE art. 3.1a)	EN 60950-1:2006 + A11:2009 + A1:2010 + A12:2011 + AC:2011





## 15.1. GL865-DUAL V3

The conformity assessment procedure referred to in Article 10 and detailed in Annex IV of Directive 1999/5/EC has been followed with the involvement of the following Notified Body:

RFI Global Services Ltd.  
Ashwood Park,  
Ashwood Way  
Basingstoke  
RG23 8BG, UK  
Notified Body No: 0889

Thus, the following marking is included in the product:

**CE 0889**

The full declaration of conformity can be found on the following address:

<http://www.telit.com/>

There is no restriction for the commercialisation of the GL865-DUAL V3 module in all the countries of the European Union.

Final product integrating this module must be assessed against essential requirements of the 1999/5/EC (R&TTE) Directive. It should be noted that assessment does not necessarily lead to testing. Telit Communications S.p.A. recommends carrying out the following assessments:

RF spectrum use (R&TTE art. 3.2)	It will depend on the antenna used on the final product.
EMC (R&TTE art. 3.1b)	Testing
Health & Safety (R&TTE art. 3.1a)	Testing



## 15.2. GL865-QUAD V3

The conformity assessment procedure referred to in Article 10 and detailed in Annex IV of Directive 1999/5/EC has been followed with the involvement of the following Notified Body:

AT4 wireless, S.A.  
Parque Tecnológico de Andalucía  
C/ Severo Ochoa 2  
29590 Campanillas – Málaga  
SPAIN  
Notified Body No: 1909

Thus, the following marking is included in the product:

# CE 1909

The full declaration of conformity can be found on the following address:

<http://www.telit.com/>

There is no restriction for the commercialisation of the GL865-QUAD V3 module in all the countries of the European Union.

Final product integrating this module must be assessed against essential requirements of the 1999/5/EC (R&TTE) Directive. It should be noted that assessment does not necessarily lead to testing. Telit Communications S.p.A. recommends carrying out the following assessments:

RF spectrum use (R&TTE art. 3.2)	It will depend on the antenna used on the final product.
EMC (R&TTE art. 3.1b)	Testing
Health & Safety (R&TTE art. 3.1a)	Testing



## FCC/IC Regulatory notices

### Modification statement

Telit has not approved any changes or modifications to this device by the user. Any changes or modifications could void the user's authority to operate the equipment.

*Telit n'approuve aucune modification apportée à l'appareil par l'utilisateur, quelle qu'en soit la nature. Tout changement ou modification peuvent annuler le droit d'utilisation de l'appareil par l'utilisateur.*

### Interference statement

This device complies with Part 15 of the FCC Rules and Industry Canada licence-exempt RSS standard(s). Operation is subject to the following two conditions: (1) this device may not cause interference, and (2) this device must accept any interference, including interference that may cause undesired operation of the device.

*Le présent appareil est conforme aux CNR d'Industrie Canada applicables aux appareils radio exempts de licence. L'exploitation est autorisée aux deux conditions suivantes : (1) l'appareil ne doit pas produire de brouillage, et (2) l'utilisateur de l'appareil doit accepter tout brouillage radioélectrique subi, même si le brouillage est susceptible d'en compromettre le fonctionnement.*

### Wireless notice

This equipment complies with FCC and IC radiation exposure limits set forth for an uncontrolled environment. The antenna should be installed and operated with minimum distance of 20 cm between the radiator and your body. Antenna gain must be below:

Frequency band	Antenna gain
GSM 850	6.43 dBi
PCS 1900	3 dBi

This transmitter must not be co-located or operating in conjunction with any other antenna or transmitter.

*Cet appareil est conforme aux limites d'exposition aux rayonnements de la IC pour un environnement non contrôlé. L'antenne doit être installé de façon à garder une distance minimale de 20 centimètres entre la source de rayonnements et votre corps. Gain de l'antenne doit être ci-dessous:*

Bande de fréquence	Gain de l'antenne
GSM 850	6.43 dBi
PCS 1900	3 dBi

*L'émetteur ne doit pas être colocalisé ni fonctionner conjointement avec à autre antenne ou autre émetteur.*



### FCC Class B digital device notice

This equipment has been tested and found to comply with the limits for a Class B digital device, pursuant to part 15 of the FCC Rules. These limits are designed to provide reasonable protection against harmful interference in a residential installation. This equipment generates, uses and can radiate radio frequency energy and, if not installed and used in accordance with the instructions, may cause harmful interference to radio communications. However, there is no guarantee that interference will not occur in a particular installation. If this equipment does cause harmful interference to radio or television reception, which can be determined by turning the equipment off and on, the user is encouraged to try to correct the interference by one or more of the following measures:

- Reorient or relocate the receiving antenna.
- Increase the separation between the equipment and receiver.
- Connect the equipment into an outlet on a circuit different from that to which the receiver is connected.
- Consult the dealer or an experienced radio/TV technician for help.

### Labelling Requirements for the Host device

The host device shall be properly labelled to identify the modules within the host device. The certification label of the module shall be clearly visible at all times when installed in the host device, otherwise the host device must be labelled to display the FCC ID and IC of the module, preceded by the words "Contains transmitter module", or the word "Contains", or similar wording expressing the same meaning, as follows:

Contains FCC ID: RI7GL865Q3  
Contains IC: 5131A-GL865Q3

L'appareil hôte doit être étiqueté comme il faut pour permettre l'identification des modules qui s'y trouvent. L'étiquette de certification du module donné doit être posée sur l'appareil hôte à un endroit bien en vue en tout temps. En l'absence d'étiquette, l'appareil hôte doit porter une étiquette donnant le FCC ID et le IC du module, précédé des mots « Contient un module d'émission », du mot « Contient » ou d'une formulation similaire exprimant le même sens, comme suit :

Contient FCC ID: RI7GL865Q3  
Contient IC: 5131A-GL865Q3  
**CAN ICES-3 (B) / NMB-3 (B)**

This Class B digital apparatus complies with Canadian ICES-003.

Cet appareil numérique de classe B est conforme à la norme canadienne ICES-003.



## 16. Safety Recommendations

### READ CAREFULLY

Be sure the use of this product is allowed in the country and in the environment required. The use of this product may be dangerous and has to be avoided in the following areas:

- Where it can interfere with other electronic devices in environments such as hospitals, airports, aircrafts, etc.
- Where there is risk of explosion such as gasoline stations, oil refineries, etc. It is responsibility of the user to enforce the country regulation and the specific environment regulation.

Do not disassemble the product; any mark of tampering will compromise the warranty validity. We recommend following the instructions of the hardware user guides for a correct wiring of the product. The product has to be supplied with a stabilized voltage source and the wiring has to be conforming to the security and fire prevention regulations. The product has to be handled with care, avoiding any contact with the pins because electrostatic discharges may damage the product itself. Same cautions have to be taken for the SIM, checking carefully the instruction for its use. Do not insert or remove the SIM when the product is in power saving mode.

The system integrator is responsible for the functioning of the final product; therefore, care has to be taken to the external components of the module, as well as any project or installation issue, because the risk of disturbing the GSM network or external devices or having impact on the security. Should there be any doubt, please refer to the technical documentation and the regulations in force. Every module has to be equipped with a proper antenna with specific characteristics. The antenna has to be installed with care in order to avoid any interference with other electronic devices and has to guarantee a minimum distance from the body (20 cm). In case this requirement cannot be satisfied, the system integrator has to assess the final product against the SAR regulation.

The European Community provides some Directives for the electronic equipment introduced on the market. All the relevant information's are available on the European Community website:

<http://ec.europa.eu/enterprise/sectors/rtte/documents/>

The text of the Directive 99/05 regarding telecommunication equipment is available, while the applicable Directives (Low Voltage and EMC) are available at:

<http://ec.europa.eu/enterprise/sectors/electrical/>



## 17. Document History

Revision	Date	Changes
0	2012-06-28	First issue
1	2012-11-09	Updated power consumption and audio section
2	2013-01-30	Updated power consumption and Conformity Assessment section, minor edits in Chapter 7
3	2013-04-04	Updated power consumption
4	2013-07-18	Updated Mechanical Drawing
5	2013-08-05	Updated Par. 6.1 “Power Supply Requirements” Added Par. 14.2 “Packing on reel”
6	2013-09-05	Added GL865-QUAD V3
7	2013-10-30	Updated Conformity Assessment section for GL865-QUAD V3 and GSM Antenna Requirements

