

GM 825 USER'S MANUAL

INTRODUCTION

We thank you for your custom. Please read this user's manual carefully so you can fully appreciate the advanced features of your phone.

This dual-band GSM phone operates entirely automatically on the dual frequency band (GSM 900-1800 MHz, as long as the network provider offers this service), thereby ensuring high quality conversation and better coverage for the radio signal. It can be used in all European Union member countries, in other countries that have implemented GSM networks and wherever (e.g. United States) a GSM-compatible 1900 MHz network has been implemented.

In addition, the phone has a WAP Browser to access Internet web sites with a data call, besides an advanced messaging system (E M S) that revolutionizes the conventional SMS message.

The GM825 user interface is designed to be friendly and easy to use; just reading the first few pages of this manual will however allow you to use the phone's basic functions immediately.

CE CONFORMITY MARK

CE 0168

The phone conforms to European Union standards

EN 60950

ETS 300342

And it has been manufactured in compliance with the following European directives:

99/5/EC

89/336/EEC

73/23/EEC

In order to make continual improvements, the specifications, design and other information given in this manual may change without notice.

© 2001 Telit Mobile Terminals S.p.A. All rights reserved.

English

INTRODUCTION	1
INSTALLING THE SIM CARD	8
Installing the SIM card	8
RECHARGING THE BATTERY	11
Low battery indicator	12
Recharging trouble	12
PRESENTING THE PHONE	13
KeysDescription	13
Indicators on the display	14
MAIN FUNCTIONS	17
Switching On	17
Switching Off	17
Emergency Calls	17
How to send a call	18
Correcting typing errors	18
International calls	18
Automatic repetition	18
Quickly send a call to a number in the phonebook	18
Answering a call	19
Automatic answer ^	19
Answer calls by pressing any key	19
Quickly turning off the ringer	19
Information on missed calls	19
Adjusting the volume	20
Turning the microphone on and off during a conversation	20

Noting down a number during a call 20
Keypad protection _ 20
Passwords 20
Security code (6 digits) 20
Autoblock 21
PIN and PIN2 codes (from 4 to 8 digits) 21
PUK and PUK2 codes (8 digits) 21
MENU - GUIDE TO THE USER INTERFACE 22
Dialogue method 22
Number method 22
MENU LAYOUT 23
main menu (overall view) 23
USING THE CALL LOG 29
Last missed calls (Menu 3-2) 29
Last calls sent 30
USING THE PHONEBOOK 31
Saving a phone number with the associated name
31
Retrieving a phone number from the phonebook 32
Using the data in the phonebook 32
Phonebook Menu 32
MANAGING CALLS 34
Options during a call 34
Turning off the ringer when the phone rings and re-
jecting a call 35
Sending DTMF tones 35
The EMS standard 37

Default animations: list and meanings 39
MESSAGES – MENU LAYOUT 40
SMS messages (Menu 2-1) 42
New (Menu 2-1-1) 42
Entering text with the conventional method t 43
Entering text with method s 44
T9 / EMS menu 45
Ins. object 45
Phonebook 46
Language 47
T9 help 47
Sending the message 47
Received (Menu 2-1-2) 48
Receiving and reading an EMS containing sounds
or images 48
50
Class 0 SMS messages 50
Written (Menu 2-1-3) 50
Parameters (Menu 2-1-4-X) 50
Name (2-1-4-X-1) 50
SMS Centre Number (2-1-4-X-2) 50
Validity (2-1-4-X-3) 51
Destination (2-1-4-X-4) 51
Protocol (2-1-4-X-5) 51
Set default (2-1-4-X-6) 51
Automatic deletion (Menu 2-1-5) 51
Reply path (Menu 2-1-6) 51

Confirm (Menu 2-1-7) 51
Information (Menu 2-1-8) 52
Cell Broadcast (Menu 2-2) 52
Activation (Menu 2-2-1) 52
Subject (Menu 2-2-2) 52
Call mailbox (Menu 2-3) 53
INTERNET WITH WAP 54
Interned access (Menu 12-1) 54
Internet configuration (Menu 12-2) 56
Browser menu 58
Preferred (menu 12-3) 62
ALL THE MENUS AND FUNCTIONS,
DEFINITIONS AND USE 63
Network services (Menu 0) 63
Phonebook (Menu 1) 63
Messages (Menu 2) 63
Calls (Menu 3) 63
Audio (Menu 4) 64
Settings (Menu 5) 66
Display (Menu 5-1) 66
Language (Menu 5-2) 67
Call waiting (Menu 5-3) 68
Keys lock (Menu 5-4) 68
Answer mode (Menu 5-5) 68
Internet (Menu 5-6) 68
Call control (Menu 6) 68
Beep every 60 seconds (Menu 6-1) 68

Call length (Menu 6-2) 68
Costs (Menu 6-3) 68
Send number (Menu 6-4) 69
Clock (Menu 7) 69
Adjustment (7-1) 69
Alarm (Menu 7-2) 69
Date format (Menu 7-3) 69
Information on the phone (Menu 8) 69
Personal number (Menu 8-1) 69
IMEI (Menu 8-2) 69
Software (Menu 8-3) 70
Information on the SIM card (Menu 8-4) 70
Total life (Menu 8-5) 70
Security (Menu 9) 70
PIN (Menu 9-1) 70
Phone (Menu 9-2) 70
Call block (Menu 9-3) 70
Fixed dialling numbers (Menu 9 4) 71
Call divert (Menu 10) 71
Always divert (Menu 10-1) 71
Missed calls (Menu 10-2) 71
Cancel (Menu 10-3) 71
GSM networks (Menu 11) 71
Network search (Menu 11-1) 71
Selection (Menu 11-2) 72
Network list (Menu 11-3) 72
Own network (Menu 11-4) 72

Select Band (Menu 11-5) 72
Internet (Menu 12) 72
ACCESSORIES 73
TROUBLESHOOTING 74
IMPORTANT NOTICES 77
QUICK HELP 79
How to make your first call 79
How to answer a call 79
How to save a number to the phonebook 79
How to retrieve a position from the phonebook 80
How to send an EMS message 80
How to reach the first SMS message 81

IMEI _____

Security code _____

Autoblock code _____

Phone no. _____

Phone no. _____

Personal notes

Note: The above data are needed to use the phone. Keep this manual in a safe place.

INSTALLING THE SIM CARD

Installing the SIM card

To be able to use the phone it is necessary to have a valid "plug-in" (small) SIM card. This SIM card is supplied by the network operator or service provider.

- ① Switch off the phone and take off the battery cover on the back, pulling the release towards the bottom of the phone.
- ② Take the battery out, paying attention not to pull on the cable connecting it to the phone.

Free the sim-card holder flap by moving the metal clip towards the top of the phone and take it out.

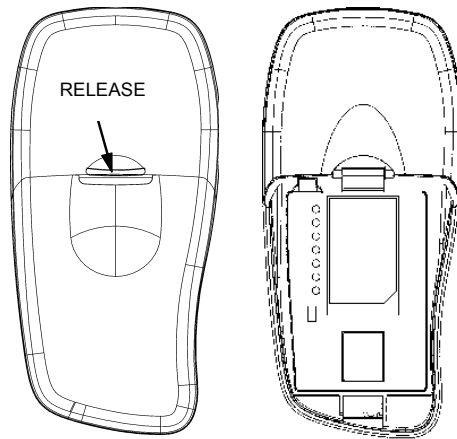

- ③ Insert the SIM card into the flap so that the contacts face into the phone, put the sim-card holder flap back into its seat and lock it with the metal clip.

- ④ Insert the battery so that the connecting cable does not obstruct the battery cover catch, as shown in the figure.

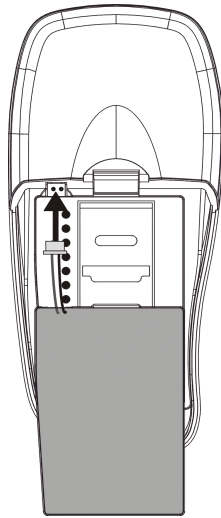

- ⑤ Place the battery cover with its bottom on the case of the phone, then gently press in the slot near the catch for it to click home.

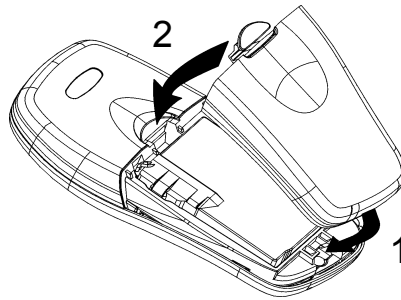

To insert the SIM card, unlock the SIM holder flap by sliding the metal clip in the direction shown by the OPEN arrow.

Then lift the flap and insert the SIM card with its contacts facing downwards, as shown here alongside.

After fully inserting the SIM card, close the flap and lock it with the clip in the direction shown by the LOCK arrow.

RECHARGING THE BATTERY

This phone is powered with Ni-MH (nickel-metal hydrate) rechargeable batteries.



Note: Use genuine batteries and battery chargers only.

Ni-MH batteries have the so-called "memory effect": a progressive loss of power efficiency if not correctly recharged. To get the best performance over time it is advisable to recharge it only when it has fully discharged.

IMPORTANT NOTICES

- Connect the battery charger solely with the battery installed.
- Although the connectors are different, **do not get the battery recharge socket on the top side of the appliance mixed up with the handsfree jack on the left-hand side.**
- It is perfectly normal for the recharge connector, when inserted in the appliance, to protrude out of the case slightly.

To recharge the Ni-MH battery, proceed as follows:

- ① Switch off the phone by holding down key .
- ② Insert the battery charger connector fully into the socket on the top of the phone, then connect the battery charger to the electric power socket (with the right voltage, as stated on the label of the battery charger).
- ③ Holding down any key (except for ) will display the following symbol:



to show the battery is discharging.

- ④ After fully discharging the battery, the phone will automatically start recharging and the previous symbol will be replaced by the following one:



- ⑤ After recharging, this symbol will appear:



The battery has charged - disconnect the battery charger from the power socket and from the phone.

Low battery indicator

When the battery has discharged completely, the phone beeps and the following symbol is displayed for a few seconds:



It is necessary to recharge the battery.

Note: Recharging requires the ambient temperature (which is **not** the one shown on the display) to be between 0° and +45°.













Recharging trouble

Any trouble (temperature too high, battery damaged, etc.) will be displayed in this way:



Note: It is advisable to put a new battery through two complete discharge and recharge cycles to increase its life and performance significantly.

PRESENTING THE PHONE

Keys	Description
	to switch the phone on and off; to enable/disable the "Mute" function during conversation
	Soft Keys: to perform the menu functions described by the symbols above the keys on the display (e.g.,  for )
	to send a call, confirm a selection; quickly see the call log; disable autoblock (see page 21)
	to access the menus, move on to the next item, access other options; pressed for 1 second to enable/disable the fast ringer silencing function
	to end or refuse a call, reject a selection, quit a menu without changing the setting, pressed for 1 second to turn autoblock back on; if held down, to quit the menu completely, irrespective of the current level
	to delete a character (or all of them if held down), figure, call, EMS, content of a phonebook position or calls lost shown on the display; to quit a menu level and go back to the higher menu level
 - 	to enter the phone numbers or characters available on each key
	besides entering *, to scroll down through menu selections, phonebook positions and EMS messages; to decrease a value; to increase the pauses (P) and waits (W) in the sequence of DTMF tones, after entering at least 1 number on stand-by
	besides entering #, to scroll up through menu selections, phonebook positions and EMS messages; to increase a value; to retrieve the corresponding phonebook position when preceded by a number; on stand-by to lock or unlock the keypad





Note: During WAP Internet sessions and when using the T9, some keys have special functions. Refer to the relevant sections for this.



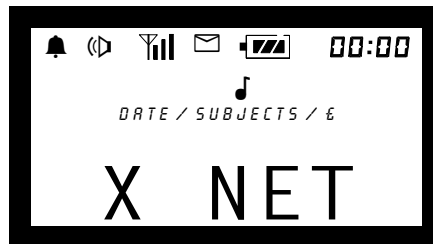















Note: The **GM825** supports a new transmission standard for short text messages (conventional SMS) that in this manual is referred to as **EMS** (Enhanced Messaging Service).

Indicators on the display

The display can show symbols and messages providing information on the operating conditions of the phone.







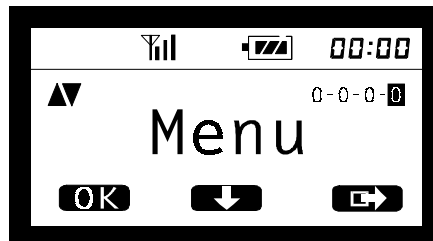

- X** indicates the nationality of the GSM network
- NET** indicates the name of the GSM network on which the phone is registered (when switching on, while waiting for network registration, the factory welcome message is displayed, which can be personalized in the relevant menu)
- DATE** depending on the menu settings, indicates the day of the week and the date or a personal message written in the relevant menu, or alternately:
- SUBJECTS** of the Cell Broadcast messages (e.g., city name), depending on the ones activated and the service offered (when the Cell Broadcast message display is enabled, the information and other messages are hidden: press  to display them.
- £** indicates the remaining credit (the function and symbol depend on the SIM card)
-  the alarm has been activated
-  an earphone or handsfree device is connected (optional extra)
-  indicates the strength of the network signal (at most 3 bars); only emergency calls are possible if there is no antenna and GSM network name, but there are bars
-  indicates there are inroad EMS messages; when blinking it indicates the SMS message memory of the SIM card is full; delete one or more EMS messages to receive others

-  indicates the battery charge: from 3 steady segments (full) to blinking (discharged). During recharging, the segments in the battery come on progressively; they stay on steady when the charge is complete
 -  displays the current time. To adjust the clock, see page 69
 -  the ringer is on
 -  the ringer is off
 -  indicates the phone is connected to the battery charger and is recharging the battery; blinking shows the phone is connected to the battery charger but the charge is complete
 -  indicates a diverted call or alternately:
 -  indicates a block on incoming calls or alternately:
 -  the block on outgoing calls has been activated
 -  the keypad is locked. To unlock it, hold down **#**, then *****
 -  indicates a block on some functions: outgoing calls, access to SMS message functions, phonebook, etc.
 -  automatic reply has been turned on
 -  roaming is active (the phone is connected on a different GSM network to the one that issued the SIM card and therefore calls pass through it with possibly higher costs)
 -  indicates the phone is registered on a GSM network that cannot be used via roaming – only emergency calls are therefore possible
 -  when on it indicates the home zone status (refer to your network operator or service provider for further information) or your own network after searching for the network from the menu.
 -  there is a message in the answering service (function depends on the SIM card)
- During a call, one of the following symbols appears on the display:
-  indicates an active outgoing call
 -  indicates an active incoming call
 -  indicates an outgoing call on stand-by (hold)
 -  indicates an incoming call on stand-by (hold)

Using  to access the menu, the display takes on this appearance:



- ▲▼ indicates there are additional fields (upwards and downwards) at the same menu level.
- 0-0-0-0 indicates the current menu level
- Menu indicates the name of the menu
-    indicate the functions activated with the corresponding bottom Soft Keys .

Caution: This manual often specifies the key to press to perform a certain operation.
A black symbol on a white background – for instance  - indicates the key to press.
A white symbol on a black background, which sometimes appears alongside (for instance, ) , is the symbol shown on the display corresponding to that key and NOT another key to press.



MAIN FUNCTIONS





Switching On

Carefully read the instructions and information supplied by the network operator or service provider with the SIM card.

- ① Insert a valid SIM card into the phone when it is switched off.
- ② Insert the battery.
- ③ Charge the battery by connecting the phone to the battery charger.
- ④ Hold down  to switch on the phone. If the phone displays the message requesting the

PIN▶

key in the code (provided with the SIM card) displayed as asterisks, then confirm with  or .

Depending on the information contained in the SIM card used, the phone automatically sets the display language (if it is in the phone memory). If the language is not in the memory, the phone will automatically use a per-set language. If necessary, change the display text language by pressing  , scroll with   to go onto the required language and confirm the selection with .

- ⑤ If the PIN code has been entered correctly the display will show:







and the phone will register with the GSM network while the display stays on stand-by.

The phone can make and receive calls only if it is switched on, a SIM card is inserted (activated with the PIN, when applicable) and it is in an area covered by a GSM network.

Switching Off

Hold down  until it switches off.

Emergency Calls

It is possible to make an emergency call at any time: press  for 1 second, dial **112** and press . Without a SIM card, press  **112** and confirm with .

Note: You must not misuse this service. Read the documentation of the network operator or service provider on emergency calls, especially if in an area covered by a foreign operator.

How to send a call

Dial the phone number with the code and press .

The display will show the number dialled, the word "Call" and the outgoing call symbol:



Once connected, information on the call status will be displayed and, when the call ends, on its length and possibly cost.



Note: Displaying the cost depends on the network and type of contract.

Correcting typing errors

Delete the last character shown on the display by pressing .

To delete the number completely, hold down .



International calls

Hold down  until + is displayed. Dial the international code of the required country, the dialling code and phone number and press .

For instance, if you want to call the phone number 123456 in Rome: +39 06 123456; or Helsinki: +358 9 123456.

Automatic repetition



When the number dialled cannot be reached because it is engaged or there is no answer, after the "Recall ?" message, it is possible, by pressing , to enable the phone to make another 10 attempts at making the call (with progressive delays: 5 sec., 1 min., etc.). An audible warning signals when the connection is made.

Press   to disable the function, straight after or while attempting to make the call.

Quickly send a call to a number in the phonebook

During stand-by, for a couple of seconds press the numerical key corresponding to the position in the phonebook (from 1 to 9) where the number you want to call has been saved (the call is sent automatically), or:



Briefly press the corresponding number and then .

To be able to correct the number before sending it, key in the number of the position in the phonebook following it with , make the correction and then press .

Note: to be able to take full advantage of this function, put the numbers you use most in the first 9 positions of the phonebook (see page 31).

Answering a call

When you receive a call, the display blinks >>CALL<< and the phone starts to ring (if the ringer is on). If the caller can be identified, the display shows their phone number (or name, if this has been saved in the phonebook).



To answer, press . To turn off the ringer without rejecting the call  or  to reject the call.

Press  to end the conversation.



Automatic answer

If this function has been activated (Menu 5-5-2), it is possible to answer incoming calls after approximately 6 seconds without pressing any keys.

Answer calls by pressing any key

If this function has been activated (Menu 5-5-3), it is possible to answer incoming calls by pressing any key (except for ,  and .

Quickly turning off the ringer

Holding down  turns off the phone's ringer (the display will show ). Only the messages on the display and possibly a blinking light (when not disabled in menu 5-1-2-1) warn of an incoming call. Hold down this key to turn the ringer back on.

Note: This selection is not saved when switching off. If you want the ringer never to ring, you need to set the ringer volume onto "Off" in the specific menu (4-1-2-1).



Information on missed calls

The message on the display in stand-by "N. X missed" (where X is the number of calls missed) indicates that the phone memory contains information on unanswered calls.

Press  to access the information on missed calls: number of calls in memory and, when available, the phone number (or name if recorded in the phonebook), date and time of the call.

Pressing  again automatically calls the indicated phone number (if available).

Adjusting the volume

Solely during a conversation the volume of the phone's speaker and/or earphone can be adjusted by pressing  (to increase the volume) or  (to decrease it).

Turning the microphone on and off during a conversation



The microphone can be turned off (and then turned on in the same way) by pressing  for 1 second.



Noting down a number during a call

During a conversation, it is possible to enter a phone number to call or save at the end of the conversation: just key it in and, after the call, this number will appear on the display.

Keypad protection 



Key protection makes it possible to prevent accidentally and unwittingly pressing keys, including key .

To lock the keypad with the display on stand-by, hold down key . The display shows  and on pressing any key, a message appears signalling protection.

To unlock the keypad, press  for 1 second followed by . Whereas, if the automatic key lock function is activated (Menu 5-4), the keypad will be locked after 30 seconds of it not being used.

Note: When keypad protection has been turned on, only emergency calls can be made.



Passwords

The phone and SIM card use different passwords, making it possible to prevent unauthorized use. When the request message is displayed (PIN, PUK, Code), key in the code (displayed as a set of asterisks) and press . The numbers keyed in can be deleted singly by pressing  a number of times.

Security code (6 digits)



The security code, programmed by the manufacturer as **000000**, permits accessing the "Security" submenu (Menu 9) of the phone.

Autoblock

If this function has been activated (Menu 9-2-4), you need to enter a code (manufacturer's default code is 1 2 3) to be able to access some important services (outgoing calls, access to phonebook and SMS menu besides various other menu functions). After entering the right code, the function is turned off: to turn it back on, press  for 1 second. If the function has been turned on,  is displayed.

PIN and PIN2 codes (from 4 to 8 digits)

The PIN (Personal Identity Number) is provided with the SIM card by the network operator or service provider and is used to prevent unauthorized use of the phone.

When you are asked to enter the PIN, key it in and press  or .

If you enter the wrong PIN three times consecutively, the SIM card is disabled and can no longer be used. Use the PUK code to set a new PIN and unlock the SIM card.

The PIN2 code, provided by the network operator or service provider, is needed to access certain protected services and functions (FDN, meters, etc.) that have to be supported by the SIM card and the subscription.





PUK and PUK2 codes (8 digits)

The PUK (Personal Unblocking Key) code is provided with the SIM card and is needed to access a locked SIM card and to change a blocked PIN.

The PUK2 code is only provided for some SIM cards. This code is needed to change or unblock the PIN2 code. For further information, contact your network operator or service provider.

MENU - GUIDE TO THE USER INTERFACE

With the menu settings it is possible to modify the phone's operation according to your needs.



These functions are divided into a main menu (first level) and several submenus (lower levels) that are accessed by pressing  and using the Soft Keys (  ) to follow the instructions shown on the display (see under PRESENTING THE PHONE).

In each menu and submenu it is possible to check and change the settings of the various functions.

The menus and submenus are accessible both with the **Dialogue method** and the **Number method**.

Dialogue method

① Press  to access the menu function.





② Press   to scroll through the menu

OR

press  to scroll downwards or  to scroll upwards.

③ On finding the required item, press   to access the corresponding submenu or to confirm the selection

OR

briefly press   to quit and return to the previous menu level without changing the setting; Hold down   to quit the menu function completely and go back to the display on stand-by.

Note: In some cases, after selecting an option, one of the following requests is displayed: "Security code", "Enter PIN", "Enter PIN2". In these cases, simply key in the required code and press  .





Number method



The menus, submenus and settings are marked by a number shown at the top right of the display. For example, 5-1-5 = "Contrast".









To access a menu function via the corresponding number, press  followed by the corresponding numbers of the menu and submenus.

MENU LAYOUT

The following pages show the layout of the phone's software menu that is accessed by pressing .

There are the various submenu levels within the items of the main menu: to activate the selected item, press  on the item; to move between items at the same menu level, press  (downwards only) or  and  (downwards and upwards respectively).

Starting from the main menu, the three Soft keys -    - perform additional functions depending on the symbol shown over them on the display:

-  more selections are available.
-  questions the network to find out the status of an option.
-  passes on to the next time within the same menu.
-  passes on to the next menu item.
-  sends the call to the number shown.
-  zooms in and scrolls through the information shown on the display.
-  quits the current menu level.
-  plays a tune.

The position of the current item in the menu layout is shown by the number (or set of numbers) at the top right of the display.

MAIN MENU (overall view)

- 0 Network services
- 1 Phonebook
- 2 Messages
- 3 Calls
- 4 Audio
- 5 Settings
- 6 Call control
- 7 Clock
- 8 Information
- 9 Security
- 10 Call divert
- 11 GSM networks
- 12 Internet

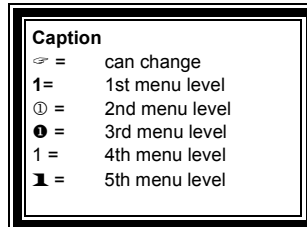

0 Network services (shown only with some SIM cards)

1 Phonebook

2 Messages

① SMS

- ① New
- ② Received
- ③ Written
- ④ Parameters
- ⑤ Del. Autom.
- ⑥ Reply Path
- ⑦ Confirm
- ⑧ Information

② Broadcast

- ① Activation
 - 1 Off
 - 2 On
- ② Subject
 - x Definable

③ Call Mailbox

- ① Mailbox No.
 - 1 Call ?

3 Calls

- ① All
- ② Unanswered
- ③ Received
- ④ Outgoing

4 Audio

① Ringer

- ① Tone
 - 1 Standard, Standard 2, Beep, Pos. empty...

Definable.

- ② Volume
 - 1 Off
 - 2 Low
 - 3 Medium
 - 4 High
 - 5 Progressive

② Key volume

- ① Off
- ② Low
- ③ High

③ Warnings

- ① On
- ② Off

④ Network tone

- ① On
- ② Only NoServ
- ③ Off

⑤ DTMF

- ① On
- ② Off

5 Settings

① Display

- ① Brightness
- ② Brightness time (light)
 - 1 Off (light always off)
 - 2 Short
 - 3 Long
- ③ Text
 - 1 Personal
 - 2 Date
- ④ Welcome
- ⑤ Contrast
- ⑥ Font selection
 - 1 Classic
 - 2 Young
- ⑦ Images
- ⑧ Animations
- ⑨ Screen saver
 - 1 Status
 - ① On
 - ② Off
 - 2 List
 - 3 Wait time

② Language

- Automatic
- English
- Italiano
- Deutsch
- Español
- Français

③ Call waiting

- ① On
- ② Off
- ③ Status

④ Keys lock

- ① On
- ② Off

⑤ Answer

- ① One key
- ② Automatic
- ③ Any key

6 Call control

① Beep every 60 seconds

- ① On
- ② Off

② Call duration

- ① Last
- ② Received
- ③ Outgoing
- ④ Total time
- ⑤ Reset

③ Costs

- ① Last
- ② All
- ③ Cost management
- ④ Reset

- ⑤ Credit
Enter PIN 2
Disabled
- Units

④ Send number

- ① Send
- ② Do not send
- ③ Automatic

7 Clock

① Adjustment

- ① Time
- ② Date
<Sunday><Monday><Tuesday><Wednesday>
<Thursday><Friday><Saturday>

② Alarm

- ① Time
 - On
 - Off

③ Date format

- dd/mm/yy
- mm/dd/yy

8 Information

- ① Own number
- ② IMEI
- ③ Software
- ④ SIM info
- ⑤ Total life

9 Security

① PIN

- ① Change PIN1
 - Enter PIN:
 - New PIN
- ② Change PIN2
 - Enter PIN2:
 - New PIN2
- ③ Use PIN
 - 1 Enabled
 - 2 Disabled

② Phone

- (Security code)
- ① Type
 - 1 On
 - 2 Off
 - 3 SIM list
 - ② Del. List
 - Sure?
 - ③ Change Code
 - New Code
 - ④ Autoblock
 - 1 On
 - 2 Off
 - 3 Change code
 - ⑤ Use default
 - Reset?

③ Block calls

- ① Outgoing
- ② Incoming
- ③ Delete
- ④ New Code

④ Fixed dial

- ① On
- ② Off

10 Call divert

① Always

- Divert to:
 - 1 Phonebook

- 2 All
- 3 Voice
- 4 Fax
- 5 Asynchronous data

② Missed calls

● Divert to:

- 1 If engaged
- 2 If cut off
- 3 No answer
- 4 All missed

③ Delete

- ① All
- ② Missed calls
- ③ If engaged
- ④ If cut off
- ⑤ No answer

11 GSM networks

① Network search

② Selection

- ① Automatic
- ② Manual

③ Network list

④ Own network

⑤ Select Band

- ① GSM900/1800
- ② GSM900/1900

12 Internet

① Home

② Settings

Profile 1

Profile 2

Profile 3

- ① Name
- ② Homepage
- ③ Proxy

- 1 IP address
- 2 IP port

④ Access

- 1 Conn. number
- 2 Call type

- ① ISDN
- ② Analogue



- 3 Login name
- 4 Password
- 5 Linger time

⑤ Set default

③ Preferred

USING THE CALL LOG

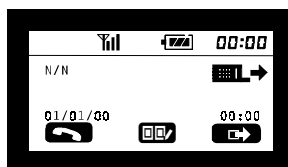

The phone can save the information on the last calls received and the missed calls. The information on the last calls sent is saved on the SIM card.

Note: When the SIM card is changed, these data are deleted from the call log. On pressing  the display shows the following information on the calls sent ():





N/N indicates the number over the total calls in the call log.





In the middle of the display there is the alternative phone number (if available) and the recipient's name, if included in the phonebook.

It is possible to save the number in the call log in the phonebook by pressing  and writing the associated name. Whereas, on briefly pressing  it is possible to copy the number on the display to change it before sending the call or saving it.

Last missed calls (Menu 3-2)





The phone can save the last 20 missed calls: unanswered calls ().

To access the list, from stand-by, press  to reach the "Calls" menu, confirm with  and then select "Unanswered".

These numbers are also displayed by pressing  when there is the message "**N. X missed**" (X = number of missed calls) and scrolling through the phone numbers with  and . To send a call to the number displayed, press ; To enter the number in the phonebook, press  and enter the associated name (see following section on using the phonebook).

Last calls sent

The phone saves the last 20 phone numbers of the sent calls (☰☛➡).

On stand-by, press , then scroll with  and  to go onto the required number among the ones saved and press  to send the call.

Press  twice from stand-by to send the call to the last number dialled.

To see the information on the 20 outgoing calls, 20 answered and missed incoming calls, refer to the section on Menu 03 “Calls” (page 63).

USING THE PHONEBOOK

With the phonebook function it is possible to save phone numbers and their associated names to the SIM card.

This phone has phonebook positions available on the SIM card. The number of positions available in the phonebook therefore varies depending on the type of SIM card used.

Saving a phone number with the associated name

- ① Key in the phone number with the relevant dialling codes, if any.
- ② Press to reach "Phonebook" and then confirm with .
- ③ Enter the name to associate with the number; press once to enter the first letter shown on the key, twice for the second one, and so on. To enter a lowercase letter, hold down the key until the character changes case (the display will show **abc**): all the following letters will appear in lowercase until a key is held down again.
- ④ Select the other letters following the same procedure. To shift the cursor to the left, press ; to the right, press . To enter a letter, shift the cursor onto the letter following the one to enter. The characters are listed below (available in lowercase too):



	space 1 , . : ; ! ? () + - * / = @ # ' \$ % & < > \ " _ \$ £ ¤ ¥ ¦ § ¨
	A B C 2 Ä Å ß Ç À Æ
	D E F 3 € É Ê Δ φ
	G H I 4 Γ { } ~
	J K L 5 Λ
	M N O 6 Ñ Ò Ó Ω
	P Q R S 7 Π Σ
	T U V 8 Ü
	W X Y Z 9 Ψ Ξ Θ
	0 +

- ⑤ Press to confirm the name or to exit the menu.
- ⑥ Press to accept ("Save to") the suggested phonebook position number or to exit the menu, or press to change the suggested phonebook position number, key in the required position and confirm with .



Note: The phone indicates supplementary network services with **(SS)** at the start of the name in the phonebook. These characters **(SS)** do not however affect name searches.

Retrieving a phone number from the phonebook





To retrieve a phone number from the phonebook with the initial of the saved name:

- ① Press  and confirm with  under "Phonebook".
- ② Key in the initial letter of the saved name.

OR



Scroll through the phonebook names listed on the SIM card with  and .

- ③ Press  to send the call.

Note: On the position saved in the phonebook, press   to move onto the position number and then onto the phone number. Briefly press  to change the digit. Make the changes, then press . When asked to "Change" confirm with  to update the phonebook.

Using the data in the phonebook

It is possible to utilize the data in the phonebook for the other services too; this function is particularly helpful when, for instance, there is a request to enter the phone number or when you want to divert incoming calls or send an EMS message to a number saved in the phonebook.

When asked to enter the number, go to the phonebook as in point ① above, select the required position with  and , then press .

Phonebook Menu

This menu is accessed by pressing  for one second within the phonebook.

The phonebook menu options are:

"Delete number": to delete the content of a phonebook position, after another request for confirmation ("Delete?").

"New": to save a new position in the phonebook.

"Fixed dial": displays and makes it possible to change (after entering the PIN2 code) the status (on or off) of the fixed dialling numbers:

FDN (Fixed Dialling Numbers) - see relevant section – "Security" menu.

“Service num.”: Access this function to use some special numbers of the single network operator, such as for instance the call mailbox number activating call waiting, which can be saved on the SIM card.

This function clearly depends on the type of SIM card and the settings defined by the network operator.



“SIM information”: provides information on the SIM card, such as the SIM phase, number of ADN (Abbreviated Dialling Numbers) number memories and MAX to indicate the maximum number of characters available to enter the name or phone number.

“Extract no.”: provides the number to change it before a call without then saving the change to the phonebook.



“Groups”: This function makes it possible to associate each of the names in the phonebook with one of the 15 groups available (5 saved as default and 10 available for the user) and then associate a ringer and an image to each one of these.

On receiving an incoming call from a number in the phonebook, the ringer associated with the group chosen, if any, will sound and the image will appear on the display, alternating with the classic screen giving the number and name of the caller.

The images that can be used are the same ones available for the EMS (see page 66 for the list), including those received from other users.

“Set”: makes it possible to associate the current name of the phonebook with one of the available groups. Scroll through the various items with the keys  and , and confirm the selection made with .

“Modify”: makes it possible to change the three typical features of each group, via the associated menu items **“Name”**, **“Melody”**, **“Image”**.

Scroll through the various items with the keys  and , then confirm with .

Select **“Empty”** to associate no sound or image to the current group.

The five default groups (“Family”, “VIP”, “Friends”, “Work”, “Other”) can be changed completely.

MANAGING CALLS

Options during a call

The phone has call management functions that can be used during a call.

During a conversation, press  for a list of commands available to manage calls.

If a new call arrives while a conversation is in progress, the display shows **“Call waiting”** accompanied by an audible warning. Pressing  brings up a menu with three options:

“Swap”: to accept the new incoming call, suspending the one in progress. Press  again to return to the previous call, putting the one in progress on hold.



“Answer”: to accept the new incoming call, ending the one in progress.



“Reject”: to reject the new incoming call, continuing with the one in progress.

Additional options available during a call in progress may be:

Close X	End call no. X (that may be multiparty)
Reject	Refuse the waiting call
Swap	Swap with the waiting call
Reply	Reply to the waiting call, ending the one in progress
Retr. Multi.	Retrieve the multiparty call
Swap to multi.	Swap with the multiparty call
Swap to X	Swap with call no. X
Return to X	Return to call no. X
Hold	Hold the current call
Hold multi.	Suspend the current multiparty call
Join multi	Joint the (current or held) call to the multiparty call
Send DTMF	To write numbers to send in DTMF
Separate X	To communicate privately with participant number X of the multiparty call
MENUSTANDARD	To access the standard menu

Turning off the ringer when the phone rings and rejecting a call

When a call arrives, it is possible to turn off the ringer by pressing   without rejecting the communication.



In addition, it is possible to reject the call by pressing   thereby sending the busy signal to the caller:







- When the divert if busy function has not been turned on, the caller will hear the busy tone.
- When the divert for missed calls function has been turned on (menu 10-2) the call is transferred to the number specified in the relevant menu.

Note: Activating the voice mailbox (service offered by network operator or service provider) may include a divert if busy service.

Sending DTMF tones

DTMF multi-frequency signals make it possible to communicate with mailboxes, computerized telephone systems, etc. Including pauses and waits in the selection of DTMF tones is therefore useful to access certain services.



The DTMF tones are active (unless disabled in menu 4-5-2) and can therefore be sent by simply pressing the corresponding key. In the case of invalid sequences, the display will show **“Wrong input”**. While sending a call containing pauses and/or waits, during these it is possible to press  or  to stop transmitting DTMF tones immediately.

If the DTMF tones have been turned off, during a call press , scroll with  , confirm **“Send DTMF”** with  , enter the required DTMF sequence and press  .

After entering at least one number, to add pause and wait tones, press  in quick succession: the display will first show **“P”** (pause) and then **“W”** (wait).

It is possible to enter a sequence of DTMF tones before sending a call: enter the phone number, then **“P”** followed by the DTMF sequence.

It is possible to dial a phone number followed by a sequence of DTMF tones to save in the phonebook or send a call.

Note: Entering **“W”** breaks off transmission of the DTMF sequence for a manual entry or for additional entries that are ended by pressing  . This function is especially helpful to enter personal passwords or phone numbers.

Note: It is extremely helpful, especially when you need to send a set of DMTF tones, to save them as a number in the phonebook.

These tone sequences are often longer than the available characters for each item in the phonebook; in this case, it suffices to split the sequence into two portions, saving them as separate items in the phonebook.

It will then be sufficient, in the phonebook item containing the first portion of the sequence, to add the command onto the end of the sequence for **number linking**, marked with bold type in the following example:

E.g., phonebook position no.102: 123456789162534**+103**.

Where **+103** is the command linking the current item (102 in this case) with the contents of item **103**, which will then be read consecutively so as to form the complete sequence.

The EMS standard

Enhanced Messaging Service

The **GM825** has a new function making it possible to enrich and make conventional SMS text messages more interesting and appealing.



EMS technology makes it possible to include sounds, images and animations in the messages, which will then be reproduced by the recipient's mobile phone (if enabled for this standard).

Note: EMS technology is a development of the conventional SMS, of which it keeps all the features. This manual therefore uses the term **EMS** to explain the meaning, even though the phone keeps the conventional term of **SMS**.



Default images and animations, already stored in the phone, are immediately available for sending to other terminals.

Some of them are transmitted as true information packs (so they take up a certain number of characters available for the message) and are reproduced by the recipient's phone exactly as the sender sees them (except, obviously, for any differences between the displays of different phones).

Images and animations of this kind, received via **EMS**, can be saved in the phone's memory and afterwards sent with other messages.

Whereas, for some animations, only the code representing them gets transmitted (e.g., moods such as joy, anger, happiness, love), which activates the display of the corresponding image on the recipient's phone; therefore, each model of mobile phone will display them differently, depending on how the manufacturer has interpreted the spirit of the message.

In this way, the message is not weighed down by transmitting a true animation, since it remains in the phone and is displayed at the command of the **EMS** received.

10 default tunes, similarly, are already included in the phone's permanent memory.

These, too, have been coded in a standard with which all **EMS** enabled terminals are compatible; of these, too, therefore only an identification code is transmitted that activates playback on the recipient's phone.

Besides these, 10 memory spaces are available for tunes that the user can compose – or receive via **EMS** – and save for future use.

Tunes, images and animations received via **EMS** can thereby be saved (except for ones that are NOT actually sent, such as full-screen animations) and reused as a ringer for the phone or included in another **EMS** to send.

The GM825 is equipped with



technology making it easier and faster to add text when writing messages.

T9 is a registered trademark of Tegic Communications, Inc. and is a patented technology in Europe, the United Kingdom and other nations.

Note: The **EMS** standard is very recent. Phones made in the past might wrongly interpret messages containing sounds/graphics and display indecipherable characters together with normal text.

Default animations: list and meanings

Animations of large dimensions stored in the phone are coded according to a standard that permits sending the recipient the command to activate the animation on their phone without sending the entire image composed of dots (which could take up a considerable amount of memory).



The EMS standard has a set of coded animations whose meaning, in the order in which they appear on the phone, is:

- Irony, winking
- Happiness
- Doubt, disbelief
- Sadness
- Enthusiasm
- Crying
- Wink
- Laughter
- Indifference
- Love – kiss
- Confusion – indecision
- Tiredness
- Anger
- Putting on glasses
- The devil

Each model of mobile phone (enabled to use EMS technology) will show different animations, but with the same meaning as the one sent by the sender.

To display the listed animations, see "**Animations**" menu **(5-1-8)** and relevant description on page 67.

MESSAGES – MENU LAYOUT

You access the EMS (Enhanced Message Service) functions menu (2-1) by pressing  to reach "Messages" and confirming twice with .

With this menu it is possible to send EMS messages and read the ones received, as well as define the parameters governing the transmission of messages.

To be able to send EMS messages, it is necessary to enter the **SMS Service Centre** number provided by the network operator or service provider.

Note: EMS and Cell Broadcast messages are services that might not be supported by your network.

2 EMS messages



- ① New
 - Send to: (Number) - (Message)
 - ① Send (Message sent)
 - ② Save
 - ③ Send and save
 - ④ Parameters
- ② Received
- ③ Written
- ④ Parameters
 - ① Definable (the parameters are taken from the SIM)
 - ② Definable
 - ③ Definable
 - ④ Definable
 - ⑤ Definable
 - ⑥ Phone parameters
 - 1 Name
 - 2 Service Centre Number
 - 3 Validity
 - 4 Destination
 - 5 Protocol
 - 6 Set default
- ⑤ Automatic deletion
 - ① On
 - ② Off
- ⑥ Reply path
 - ① On
 - ② Off
- ⑦ Confirm
 - ① On
 - ② Off
- ⑧ Information





2 Cell Broadcast

- ① Activation
 - Off
 - On
- ② Subject

3 Call mailbox

- ① Mailbox number

In this menu the Soft Keys -    - perform additional functions depending on the symbol shown above them on the display:

 pressed briefly to change the method of entering text (, , ); held down to access the "T9" submenu and to add animations/sounds/phone numbers taken from the phonebook.

 to reply to a message received or to update one saved

 to read a message and scroll through the display

 to move on to the next item at the same menu level

 to quit the menu

T9 / EMS menu

1 Add object

- ① Sounds
- ② Melodies
- ③ Images
- ④ Animations

2 Preview

3 Phonebook

4 Language

- ① English
- ② Italiano
- ③ Deutsch
- ④ Español
- ⑤ Português
- ⑥ Français
- ⑦ Ελληνικά
- ⑧ Türkçe



5 T9 help

Note: To access the T9 / EMS menu, whose diagram is shown here, hold down the  key in the text editor when composing a new message.

SMS messages (Menu 2-1)

New (Menu 2-1-1)

This function makes it possible to compose and send a new message.

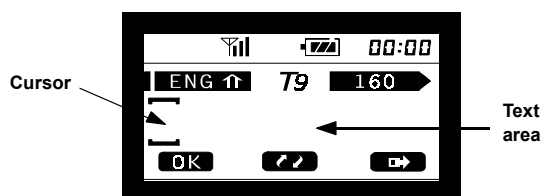

Enter the recipient's number, confirming it with , or press  to take the number from the phonebook.

You then pass on to the text editor, which appears as shown in the figure:







The band of symbols above the text area contains several elements corresponding to different functions.





In detail, from left to right:

 indicates the start of the EMS message; if there is any hidden text,  appears in its place on the left. To display the hidden text, press  several times to scroll left.





 specifies the set language to enter text in "T9" mode.



To change the language used, see the T9 menu on page 45.

 indicates the 'Shift' function (uppercase first letter, lowercase the other letters of the word); on pressing   is displayed to indicate the 'Caps lock' function (uppercase for the whole message); on pressing  again, no symbols appear, indicating the text will be lowercase.

 indicates the function of the method of entering the message. By pressing  it is possible to change the method to  (conventional message typing) and to  (entering numbers).

 is the meter indicating the number of characters still available when composing an EMS message.

On the far right  indicates there is space available for writing or, if  appears there is hidden text to the right of the display (press  to see the text to scroll the text to the right) or if  appears there is no more space available for writing.

By repeatedly pressing  e  it is possible to scroll through the text of the message to the left and right respectively.

Linked messages





With the Gm825 you can compose messages longer than 160 characters as it splits them up automatically, optimizing the division of the contents, into several single messages that will get sent to the same recipient.

The remaining character count in the text editor at top right is accompanied by a number from 1 to 5 (maximum length) indicating the number of single messages of 160 characters used to contain the current text.

Linked messages are joined automatically when they are received and the text is presented as a single unit.

Entering text with the conventional method

Each key corresponds to more than one letter. Briefly press the key once for the first letter, twice consecutively for the second, 3 consecutive times for the third, etc. (see page 31).

For instance, to write the word BUS - press  twice consecutively to key in the letter "b", wait for the cursor to move on, press  2 consecutive times to key in the letter "u", wait for the cursor to move on, and briefly press  4 times to key in "s". Then press  to create a space to continue with the message.

Entering text with method [T9]

To write a word, press the keys containing the letters of the required word just once and consecutively, irrespective of their sequence on the key, as on a typewriter. The phone will automatically form the word by offering a list of alternative words taken from a database (dictionary) of words. This is easier if you do not look at the display until you have finished keying in all the letters of the word.

For instance, to write **BUS** with T9 – press keys **2nd**, **6th** and **7th** consecutively. Then press **#** to create a space in order to continue with the message.

If the word composed automatically is not the required one, it is possible to choose a different word from the database with **6th**. After finding it, press **↵** to move on with the message. Whereas, if the word is not in the list, delete it with **⌫** and briefly press **≡** to change the method of entering text into **[ABC]**: then key in the new word with the conventional method and afterwards confirm with **↵**. Pressing **≡** twice more takes you back to the **[T9]** method. The new word formed will automatically be added to the phone's database with **[T9]** (in the future it will no longer be necessary to key it in from scratch).

NUMBERS: briefly press **≡** and select **[123]**, then key in the number. Press this key twice more to go back to **[T9]** mode.

PUNCTUATION: To add punctuation press **1st**: T9 is able to guess the punctuation needed according to the set language. If the punctuation is not as required, press **6th** to enter other symbols.

T9 / EMS menu

By holding down  while composing a message in the text editor, it is possible to access the 5 menus to manage the T9 system and to enter images and tunes in the text messages:

- 1 – “**Ins. object**” to add images and sound to the current message
- 2 – “**Preview**” to display the message as the recipient will see it – with graphics and sound – to check it is correct before sending it
- 3 – “**Phonebook**” to enter a number taken from the phonebook in the message
- 4 – “**Language**” to set the language to use in T9 mode
- 5 – “**T9 Help**” T9 system help

Ins. object

With this function it is possible to add to the message the images or sounds available in the 5 available submenus:

1 – Sounds

10 pre-coded sounds in each GSM model enabled for the EMS standard; they can neither be changed nor deleted.

2 – Melodies

The phone is supplied with 10 initially empty spaces the user can use to compose personalized tunes (see page 64) to then send via EMS or to save those received from other terminals.

3 – Images

There are 25 available images of different sizes that are transmitted and displayed by the recipient exactly as the sender sees them on his or her display (adding these objects to an **EMS** therefore takes up more space). Besides these, it is possible to save up to 10 images received from other terminals via **EMS**.

4 – Animations

15 animations of large dimensions representing moods or situations of daily life (e.g., enthusiasm, laughter, indifference, sadness, crying) and of which, instead of the entire image, only a standard code is transmitted that, on the recipient's phone, activates the corresponding image (therefore a different interpretation of the same feeling) as interpreted by the manufacturer. The image will therefore only be identical between two of the same models.

Besides these, **there are 5 small-sized and 10 larger animations**; they are transmitted and displayed exactly and not re-interpreted by the recipient.

After selecting the object to add to the message (sound or graphics), confirm the selection with ; you automatically go back to the text editor, which will display a symbol (a **musical note** or an **empty box**) showing that the object (sound or image) has been included.

EMS objects take up part of the space normally reserved for text; this consumption is indicated by a decrease in the remaining space shown by the meter at top right.



An attempt at adding an object whose size exceeds the remaining space is signalled by "No space left" and you are taken back to the text editor.

5 – Preview

This function makes it possible to display the EMS message – not to change it – in order to check the text and objects included are correct.

Animations and images appear as in reality and not represented by a symbol as in the text editor and, at the same time, the tunes included in the message are played.

Phonebook

Select this item if you want to add a phone number saved in the phonebook to the text in the message; scroll through the various items of the phonebook with  , and copy the required number, confirming with  (you are automatically taken back to the text editor).

Language

To use a different language with T9 composition (even within the same message), go onto option 1 - "Language", confirm with  and scroll to select the required language. The available languages are: ENGLISH, ITALIANO, DEUTSCH, FRANÇAIS, ESPAÑOL e PORTUGUÉS.

T9 help

The T9 help is text that automatically scrolls on the display with essential information for using the T9 composition technology.

Sending the message



To send the message, press  and choose one of the following options: "Send", "Save", "Send and save" described below.

Send (1)

To send the message.

If the message has been sent, the display will show "Message sent" or "Message not sent" (with the reason for not sending it) for a few seconds.

If the message has been sent, the display will again show "Send to:" with the same phone number.

It is then possible to send this EMS message to the same number or to a different number - by pressing  and entering the new number, or exit the menu by pressing .

Save (2)

To save the message without sending it (you can send the message later).

When  blinks on the display, the message memory is full: to receive or save others, delete some of them.

Send and save (3)

To send and save the message.

Parameters (4)



To assign the set of "Parameters" (Menu 1-4) while entering the SMS message, see the relevant paragraphs on page 50.

Received (Menu 2-1-2)

When you receive an SMS/EMS message, the display shows the following image with an audible warning:



When the image disappears, the display continues to show  until the SMS message is read.

To receive the message received press  to reach the Messages menu and confirm with ; the following message heading will appear:

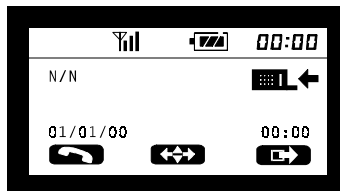

It will show: the current number over the total number of SMS messages (N/N), the sender's phone number (and name, if saved in the phonebook), the date and time when the message was received.

To scroll through the list of messages use keys  and .







To read and scroll through the content of an SMS message, press .

To go back to the message heading, press .

Receiving and reading an EMS containing sounds or images

An EMS message is presented and received as any other SMS.

The images and animations appear together with the text, just as the sender composed the message.

To scroll through the message, use  and ; if there is more than one object, shift the selection from one to another with . If there is more than one object on the same row,  shifts the selection from one to another without scrolling through the message; on selecting the last object, the symbol of the  key turns into  and the text starts scrolling.

A selected object is framed with a dotted line





When a "Melody" object is selected as in the figure,





the sound is played back.





To **save an object received via EMS**, select it and press  .



If there is sufficient space available in the phone memory, the phone will ask for confirmation ("**Save?**") - confirm with   or cancel the operation with .

If the object to save is a melody, you are asked for a name to associate with it, which will then appear in the list of available ringers (menu 4-1-1).

The images and animations saved will instead appear in the list activated by the menu Settings-Display-**Images/Animations** (menus **5-1-7** and **5-1-8**).

To delete a message press  for 1 second and then confirm the request to "**Delete?**" with key .

To reply to a message, simply press   and write the text; after confirming with , press  again when asked to send or scroll through the options with .

While the text of a message is displayed, press   to go back to display the heading.

Note: Only pictures and animations actually received via EMS (obviously not ones where only the identification code is transmitted) can be saved and afterwards deleted from the phone memory, likewise tunes composed by the user or received via EMS.

Class 0 SMS messages

Some network operators and service providers send a special type of SMS message. These class 0 SMS messages are automatically shown on the display, but **they are not saved** to the SIM card (and so are automatically deleted when the phone is switched off).

Written (Menu 2-1-3)

To read messages previously written and saved. The display is similar to that of messages received. By pressing  on the heading of a message it is possible to update its text and the number of the recipient, to then send it.

Parameters (Menu 2-1-4-X)

Before sending your first SMS message, in the following submenu it will be necessary to set all the data needed to activate the SMS message function or at least the SMS Service Centre Number provided by the network operator or service provider. If they are not changed, these parameters will hold good for the following SMS messages too.

It is possible to save several parameters on the SIM card in the “**Definable**” positions (scrolling with ). The number of parameters that can be saved depends on the SIM card. The “**Phone Parameters**” option (2-1-4-6) on the other hand saves the parameters to the phone memory and not the SIM card.

Name (2-1-4-X-1)





This function makes it possible to assign a name to the profile (for instance, that of the network operator to which the profile refers). This option turns out to be helpful when you use different network operators for each one of which there will be a specific profile, setting the parameters of the 4 submenus (Service Centre Number, Validity, Destination and Protocol).

SMS Centre Number (2-1-4-X-2)

Enter the Service Centre number provided by the network operator or service provider.

Note: Do not get this number mixed up with that of the message recipient.

Validity (2-1-4-X-3)

This network service makes it possible to set a length of time (Minutes, Hours, Days and Weeks) during which the SMS messages will be stored by the Service Centre while it tries to send them. To move between items, press  ; to change the units of time, use  and .

Note: If the maximum time entered exceeds the time laid down by the Service Centre, the message is automatically reduced to their specifications.

Destination (2-1-4-X-4)

This function makes it possible to save the phone number of the recipient of new EMS messages. The number appears automatically under **"Send to"** when you send a new EMS message, barring the opportunity of changing the number by pressing . This function is particularly helpful if you often send EMS messages to the same recipient.

Protocol (2-1-4-X-5)

This network service makes it possible to convert the EMS message into different formats, such as: ISDN and PSTN services, Pager, E-mail, Fax, etc.

Note: Change the set value "0_ Text" only after calling the network operator to check whether other formats are supported.

Set default (2-1-4-X-6)

This function sets the parameters set in the previous menus as automatic. If there is more than one profile saved, it permits choosing and applying the most suitable one (until another one is set as default) according, for instance, to the EMS Centre used, the recipient's phone number and the protocol to be used.

Automatic deletion (Menu 2-1-5)

This function makes it possible to turn SMS message automatic deletion on or off after they have been read.

Reply path (Menu 2-1-6)

This network service permits the EMS message recipient to send a reply using the same EMS Centre as the sender.

Confirm (Menu 2-1-7)

This network service lets the sender obtain confirmation from the SMS Centre that the message has been received.

Information (Menu 2-1-8)

This function provides information on the EMS messages on the SIM card. In detail: the first row shows the EMS messages present and the maximum permissible number of messages; the following two rows show, respectively, the number of messages received and the ones written and saved.

Note: Since all the EMS messages (written, saved and received) are saved on the SIM, they take space from its memory and it is therefore advisable to delete them when you no longer need them.

Cell Broadcast (Menu 2-2)

With the Cell Broadcast service, the network operator or service provider sends messages to all the subscribers in a certain area.

Note: The number and language of the Cell Broadcast subjects strictly depend on the SIM card used and change according to the type of service implemented by the network operator or service provider.

Activation (Menu 2-2-1)

This function, if activated with , displays the options "On" (2-2-1-2) and "Off" (2-2-1-1) for Cell Broadcast messages.







If the function is on, the display will automatically show the messages when on stand-by.

If necessary, the rows of the message will be displayed in succession.

To remove Cell Broadcast from the display temporarily, press .

Subject (Menu 2-2-2)



It is possible to select different Cell Broadcast message subjects.

Choose the subject by scrolling through the list with  or  and  and , or define a new subject with a 3-digit number, confirm with  or quit the function. If the first option is "All" then all subjects will be received; whereas, if it is another item, press  to delete the selection and confirm with .

Call mailbox (Menu 2-3)

This function makes it possible to listen to voice messages saved in your call mailbox or on an answering service.

To access the call mailbox service, enter the number provided by the network operator or service provider, or enter a private number to access your answering service.



Enter the **"Mailbox number"**, confirm with  **OK** and select whether to call the saved call mailbox number when asked **"Call?"** with  **OK** or press  **Cancel** to change the mailbox number.

To make full use of the functions for sending DMTF tones, often used for the call mailbox, see the relevant section on page 35 and the note on page 36.





INTERNET WITH WAP

Interned access (Menu 12-1)

Accessing and surfing the Internet with WAP is better in optimum conditions of reception of the radio signal – and these conditions need to be maintained throughout the Internet session (Ytll).

If the *Call waiting* service has been activated with the network operator and a call arrives during an Internet session, the display will show the warning: press  and choose whether to “Reply” by pressing  to accept the call and close the Internet connection (after finishing the call the phone will automatically return to the Internet session) or whether to “Reject” by pressing  and keep on browsing. If *Call waiting* is not active the Internet session will not be interrupted.

It is possible to access Internet WAP sites as follows:

Press  to access the main menu, scroll through the various menu items with ,  or  to reach “Internet”.

Confirm the request to connect to the Web by confirming with  under “Home”. At the first attempt to access the Internet, the display shows:



After a few seconds, this image disappears and is replaced by the following screens in sequence, indicating the WAP connection has been started and information is being exchanged:



The first time you access a WAP session, there may be a request to enable security; confirm with .

The following image shows a typical WAP page by way of example (specifically, a portion of the browser menu).

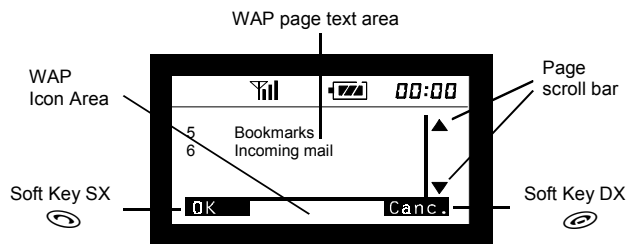

The following symbols may be displayed in the WAP icon area:

- indicates the secure connection function (only certain sites)
- indicates there is mail not yet sent
- an attempt at connection is in progress
- the phone is connected to the Internet
- the Internet 'alert' icon (warnings sent from the Internet)

When browsing the Internet some keys take on special functions:

- to scroll down (or to the right) on the WAP page
- to scroll up (or to the left) on the WAP page
- held down to access the Browser Menu;
pressed briefly to scroll down through WAP pages
- pressed briefly to move 'back';
In text editors, it works as delete and when held down it deletes all the text; in this case, to use as 'back' it is first necessary to go back to the start of the text with , then press ; held down to go back to the homepage
- as a Soft Key function (option at top left of the display)
- as a Soft Key function (option at top right of the display);
held down to end the WAP session

Internet configuration (Menu 12-2)



The configuration menu is in the main menu 12 "Internet" and it has the following layout:

② Internet

Profile 1,2,3







- ① Name
- ② Homepage
- ③ Proxy
 - 1 IP address
 - 2 IP port
- ④ Access
 - 1 Conn. number
 - 2 Call type
 - 1 ISDN
 - 2 Analogue
 - 3 Login name
 - 4 Password
 - 5 Linger time
- ⑤ Set default

The phone might already have been configured to access the Internet.

If the phone is configured, the Internet access data are already set in this menu: repeatedly press   to quit the menu and return to the display on stand-by, then access menu 12 "Internet".

If the phone is not configured (the fields are empty or contain incorrect data), refer to the subscription documentation or contact the network operator to get the data to set.

The phone can have at most three "Profiles" depending on the factory settings.



To enter the configuration data, select one parameter at a time and confirm with , enter the figure and confirm with  and then pass on to the next figure. Press  to go back by one menu level (without confirming the changes).  is used to scroll through the options;  to delete a figure. The arrow  to the left of the menu item indicates the function is active.

After entering all the data, select "Set default" (5-6-X-5) to activate and apply the current Profile.

Name (12-2-X-1): This is the name associated with each one of the three available profiles that appears at the higher menu level when the phone offers the selection of the profile whose parameters are to be displayed/changed.

Homepage (12-2-X-2): enter the URL address of the opening page (if other than the Proxy WAP it might not be accepted). It usually starts with "*http://wap...*"

Proxy (12-2-X-3): This menu item opens up two submenus where you can define the Proxy to connect to:

IP address (12-2-X-3-1): Enter the IP address (of the Proxy) using   to shift the cursor between the digits of the parameter (when a field is full the cursor automatically moves onto the next field).

IP port (12-2-X-3-2): Enter the required figure (usually 9201 or 9203).

Access (12-2-X-4): This menu takes you to the following 5 submenus:

Conn. number (12-2-X-4-1): is the number to connect to for the WAP connection (as with a normal modem connection).

Call type (12-2-X-4-2): the call to make the connection may be ISDN or Analogue.



Login name (12-2-X-4-3): enter the user name if required.

Password (12-2-X-4-4): enter the password if required.

Linger-Time (12-2-X-4-5): the connection time in seconds after which if there is no data exchange the call is ended.

Set default (12-2-X-5): to set the current Profile as the default.

Note: "X" indicates the current Profile (1, 2 or 3).

After entering all the data, repeatedly press   to quit this menu and access menu 12-1 "Home" to start the connection.

Browser menu

During a WAP Internet session hold down  to access the Browser menu (the menu layout is shown below) that provides a set of extremely useful functions to surf the Internet with the WAP.

Note: The WAP Browser uses the phone languages as regards the functions, Soft Keys and error messages even if during the Internet sessions different languages could be used.

The layout and meaning of the various Browser menu items are shown below:

- 1 Back
- 2 Home
- 3 Exit
- 4 Bookmark site
- 5 Bookmarks
- 6 Mail in
- 7 Refresh
- 8 Settings
 - ① Homepage
 - ② Circuit prompt
 - ③ Circuit wait
 - ④ Key pressure timeout
 - ⑤ Protection
 - ① Connection prompt
 - ② Protection prompt
 - ③ Current certificate
 - ④ CA certificates
 - ⑤ Authentication
 - ⑥ Coding
 - 1 Check password
 - 2 New password
 - ⑥ Advanced
 - ① Go to URL
 - ② Show URL
 - ③ Restart Browser
 - ④ Off-line services
 - ⑤ Mail out

9 SMS

? Information on...

- ① Openwave
- ② Security
 - Schlumberger
 - RSA

1 – Back

To go back to the previous page.

2 - Home

To go to the opening page.

3 – Exit

To shut down the WAP session and go back to the normal phone stand-by status.

4 - Bookmark site

This function makes it possible to add the current site to your list of bookmarks.

5 - Bookmarks (favourite WAP sites)

Shows the list of your favourite WAP Internet sites.

6 – Mail in

The main in box is displayed together with a notice if there are any new messages.

7 - Reload

To reload the current WAP page.

8 - Settings

8-1 Homepage

If enabled by the Proxy it shows the full address of the homepage and offers the possibility of changing it (the setting of this function contained in the Proxy has priority over the one contained in the user profile).

8-2 Circuit prompt

This makes it possible to enable or disable the message displayed whenever the system does not have a data circuit and needs a data call to re-establish the connection.

The text of the message displayed is

“The circuit is not operative. Start a data call?”.

8-3 Circuit wait

This makes it possible to define the length of the maximum wait before disconnecting from a data circuit. The value set by the user is stored in the phone, but some providers define a minimum limit that has priority over this value. The maximum value is 9999 seconds.

8-4 Key pressure timeout

In general, every key can be used to obtain different characters, pressing it several times in succession. Timeout is the length of time after which the last character displayed becomes final and the cursor passes on to the next position.

This function makes it possible to change the speed with which the cursor passes on to the next position, choosing it from Fast, Medium Slow (respectively 1 – 1.5 – 2 seconds).

8-5 Protection

This opens the following 6 submenus:

8-5-1 Connection prompt

To enable or disable the “Protected connection stability” warning.

8-5-2 Protection prompt

To enable or disable the message, “You are about to enter an unprotected area. OK?” that appears before you leave a protected area.

8-5-3 Current certificate

The phone utilizes digital certificates (called “CA”) issued by trusted third parties to authenticate some web sites. On accessing this function, the phone shows the available information for the certificate being used for the current session.

8-5-4 CA certificates

This function displays the list of CA certificates stored in the phone, to display the main data and enable or disable them.

8-5-5 Authentication

The phone can save the user name and password entered by the user in a local memory when you access web sites so as to then re-enter them automatically when you access them again. With this function it is possible to enable or disable this possibility. Disabling also deletes the entire memory of user names and passwords.

8-5-6 Coding

This shows the Browser coding control code (**8-5-6-1 – Check password**) or forces calculation of a new code (**8-5-6-2 – New password**).

8-6 Advanced

Confirming access with  takes you to the following 5 submenus:

8-6-1 Go to URL

To enter the address of a web site to go to. Pressing  produces a list of special characters (punctuation, etc.) that can be entered by pressing the key corresponding to the number associated with each one of them.

8-6-2 Show URL

Shows the URL of the current site.

8-6-3 Restart browser

Deletes the temporary internal memory (cache) of the browser and starts a new session with the proxy.

8-6-4 Off-line services

Shows a list of applications already loaded in the phone that can be used without accessing the GSM network.

8-6-5 Mail out

Shows the mail items in the out box.

9 SMS

Confirming this selection takes you to the SMS menu (see page 40) without ending the WAP connection.

? Information on...

The browser provides the main information (release, copyright) on Openwave (WAP management software) and the available security systems (Schlumberger and RSA).

Preferred (menu 12-3)

The link to some sites, variable depending on the software release and on the possibilities offered by the network operators, has been saved in the phone for faster use.

To access the Internet with the WAP it is necessary to use a SIM card enabled for data calls and subscribe to the service of the network operator or service provider. Contact them to obtain more detailed information on the WAP services they offer.

The WAP Internet pages displayed on the phone are formatted differently to the Internet pages on a computer. Obviously, not all the graphics normally shown on the monitor of a PC can be faithfully reproduced on the display of a mobile phone, but the GM825 makes it possible to display graphic objects that till now were excluded from WAP sessions.

Note: It is possible to access the browser menu even without a web connection by pressing the  key for longer than one second after selecting and confirming "Internet" (menu 12).

Note: The **GM825** supports the **Download for fun** function. It is possible to download tunes from some sites (**iMelody** standard) and save them in the phone to be used as ringers, as well as Screensavers (see page 66) provided the format is compatible (WBMP – 97x32 pixels).

ALL THE MENUS AND FUNCTIONS, DEFINITIONS AND USE

Network services (Menu 0)

The presence, description and configuration, number and type of services offered in this menu depend on the SIM card used.

Contact your network operator or service provider to obtain more detailed information on the services they offer.





Phonebook (Menu 1)

Confirming this menu item with  takes you straight to the phonebook. See the relevant section, "USING THE PHONEBOOK" on page 31.

Messages (Menu 2)



The "Messages" menu, via the functions described on page 40, makes it possible to send or read EMS messages, define their working parameters, manage the call mailbox and Broadcast messages (sent by the network operator).

Calls (Menu 3)



This function makes it possible to display the last 20 outgoing calls ( ) and the last 20 answered ( ) or unanswered () incoming calls.





Refer to the section, "USING THE CALL LOG".

The available options are: "All" (3-1) to display all the calls in the memory; "Unanswered" (3-2) to display the unanswered incoming calls; "Received" (3-3) to display the answered incoming calls and "Outgoing" (3-4) to display the sent calls.

To scroll through the sequence of phone calls in each option, press  and  or .

To send a call to the number displayed, press .

To associate the displayed number with a name and save it in the phonebook, press  , enter the name and confirm.

To delete a call, display it and press ; the display will show "Delete this?": confirm with   or press   - ("Delete all?") and confirm to delete ALL the calls from memory.

Audio (Menu 4)

This menu contains 5 submenus:

Ringer, Key volume, Warning tones, Network tone and DTMF.

In the "Ringer" menu (4-1) with "Tone" (4-1-1) you can set the type of warning tone when a call arrives and its "Volume" (4-1-2): "Off", "Low", "Medium", "High" and "Progressive".

By selecting "Tone" (4-1-1) (and scrolling with keys \leftarrow^* and \rightarrow^*) it is possible to define the phone's ringer, choosing it from:

19 default tunes ("Standard 1, 2, 3...Beeps 1, 2, 3...Melodies 1, 2, 3...");

10 originally empty positions ("Empty" positions) where it is possible to create and save short tunes to send also via EMS;

the "Definable" option (4-1-1-00), with which it is possible to personalize your ringer (longer than the previous personalized ones, but they cannot be transmitted).

To compose personalized tunes there are two octaves, and each of the notes is represented by a letter.

The notes of the lower octave are represented by uppercase letters

C-D-E-F-G-A-B

while the second (higher) octave is represented by the same lowercase letters:

c-d-e-f-g-a-b.

The correspondence between the keys to press and the corresponding notes is highlighted in the following drawing:

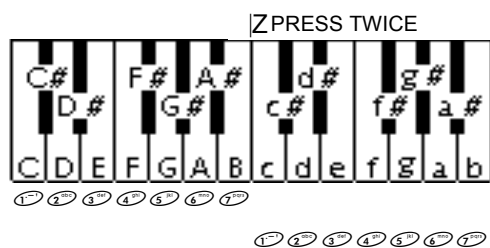

The letters representing the notes are entered with keys from 1^{st} to 9^{th} . Simply pressing one of these keys produces the uppercase letter (note of the lower octave). To obtain the corresponding note of the higher octave, press the same key TWICE in succession

To obtain the semitones (notes with a sharp, e.g., C#) the # character should be added straight after the letter representing the note by pressing key 6^{th} .

Immediately afterwards it is necessary to enter a character to define its length. Notes can have 4 different lengths; pressing key 9^{th} from one to four times in succession and obtaining the symbols j ' W c ' Z

Note: the character for the length is fundamental .

Between notes (therefore between the character for the length of one note and the letter of the next one) it is possible to add a pause by pressing key 6^{th} from one to four times and obtaining the characters q ' ' ' Y - .

Movements within the composition are made with 4^{th} and 5^{th} . Any errors or an excessively long string are signalled by a warning tone and the cursor will automatically go onto the first wrong note. 3^{rd} 2^{nd} plays back the composition that has just been written.

EXAMPLES:

C# of the 1st octave

Press 1^{st} - 6^{th} - 9^{th} (from one to four times depending on the length)

f of the 2nd octave plus pause:

Press 4^{th} twice to enter "f", then 9^{th} (from one to four times depending on the length) followed by 6^{th} (from one to four times to select the pause before the following note).

The composition therefore has the following syntax:

NOTE – [SHARP] - NOTE LENGTH – [PAUSE]

The parameters in brackets are optional

After writing the tune, confirm with

If you are composing one of the personalized melodies that can be transmitted via EMS ("Empty" item in the list of tunes), you are asked for a name to give the composition. This name will then replace "Empty" in the list.



In the other menu options it is possible to set the **"Key Volume"** (4-2) (**"Off"**, **"Low"** and **"High"**), the tones of the **"Warning tones"** (4-3) informing you of the connection, switching the phone on and off, connecting and disconnecting the battery charger, as well as the low battery charge.

With **"Network tone"** (4-4) it is moreover possible to activate warning tones informing you if there is or is no GSM network coverage, or only if there is no coverage.

The **"Active"** option in **"DTMF"** (4-5) is moreover used to immediately send the tone corresponding to the key pressed in multifrequency transmissions.

Settings (Menu 5)



Display (Menu 5-1)

This function makes it possible to change the **"Brightness"** (5-1-1) of the display, with  and , and the **"Light time"** (5-1-2) since last pressing a key. In addition, it is possible to set the **"Text"** (5-1-3) shown on the display on stand-by, choosing from **"Date"** and **"Personal"** text. The personal text, at most 40 characters long, is written with the conventional method.

The **"Welcome"** option (5-1-4) makes it possible to write the welcome message that appears for a few seconds when switching on the phone on the display instead of the network operator's name.

Note: If the personal text exceeds 16 characters, the text will scroll on the display. The maximum length is anyhow 40 characters.

With **"Contrast"** (5-1-5) it is possible to adjust the light/dark of the display and with **"Select Font"** (5-1-6) to set the font of the messages on the display.





"Images" (5-1-7) makes it possible to use   to scroll through the images stored in the phone, starting from the default ones and then passing on to the ones received via EMS, which can be deleted by briefly pressing .

"Animations" (5-1-8): similar to the situation for images, it is possible to display all the animations and delete the ones saved by the user by pressing .

"Screen saver" (5-1-9): the GM825 has a screen saver that (if activated in the relevant menu) appears in the graphic area of the display after a certain length of time has passed without any keys being pressed. Besides the screen saver installed on the phone, it is possible to save others downloaded via WAP with the Download for fun function.

The menus dedicated to managing the screen savers are, in sequence:

"Status" (5-1-9-1): to turn the Screen saver function on and off

"List" (5-1-9-2): to display the saved screen savers directly (the first one is the one resident in the phone. To scroll through the available images, press  . The saved Screen savers (except for the first one, which is stored permanently in the phone) can be deleted by pressing  and confirming with  when asked to "Delete?".

To select an image as a Screen saver, display it and confirm with ; for a few seconds the display will show "Screen saver selected" confirming the choice made.

To quit the display without making any selection, press  .

"Wait time" (5-1-9-3): in this menu it is possible to define the time in seconds after which the screen saver comes on: enter the time, then confirm with .



Language (Menu 5-2)

This function makes it possible to choose the language in which all the messages on the display are shown. By selecting "Automatic" the phone automatically recognizes the nationality of the SIM card and displays the messages in the language associated with it (if the language is stored in the phone).





Call waiting (Menu 5-3)

This network service, if turned on, makes it possible to be informed during a conversation of the arrival of another call with an audible warning. The submenu makes it possible to: turn on and off and check the service status.

Keys lock (Menu 5-4)

This function makes it possible to lock the keypad automatically approximately 30 seconds after last pressing a key. It is unlocked as for manual locking: press  for 1 second and then .

Answer mode (Menu 5-5)

This function makes it possible to set the method of answering a call: pressing , automatic (after 6 seconds without pressing any key), or pressing any key (except for ,  or .

Internet (Menu 5-6)

If the phone has already been configured for Internet access via WAP this menu contains the connection data in profiles (and it is not necessary to set anything); otherwise, it is necessary to enter the data (provided by the network operator or service provider) for the configuration in the submenus.

For more details on this subject, please read the section INTERNET WITH WAP.

Call control (Menu 6)**Beep every 60 seconds (Menu 6-1)**

This function turns on an audible warning on each minute of conversation.

Call length (Menu 6-2)

This function indicates the length of the last call (6-2-1), of all the calls received and the outgoing ones, as well as the total conversation time. This last option, if confirmed with , makes it possible to "Reset" (6-2-5) the meters.

Costs (Menu 6-3)

This network service makes it possible to know the amount charged for the "Last" (6-3-1) and for "All" (6-3-2) the calls. In addition, with the "Cost management" option (6-3-3) it is possible, after keying in the PIN 2 code, to enter the unit value and currency. With "Reset" (6-3-4) and entering the PIN 2 code you reset all the calculations, while "Credit" (6-3-5) makes it possible to limit the units to a fixed number, after which the call is cut off.

Note: This function depends on the SIM card and on the network operator.

Send number (Menu 6-4)

This network service makes it possible, for all outgoing calls, to choose whether to

“**Send**” (6-4-1), “**Not send**” (6-4-2) your phone number or, with “**Automatic**” (6-4-3), to leave the network setting unaltered.

On the contrary to calls, EMS/SMS messages ALWAYS contain the sender's number.

Clock (Menu 7)

Adjustment (7-1)

This function sets in sequence: the time (always displayed at top right of the display) and, after confirming, the date and day of the week.

To pass from one value to another, press ; change the values with and ; confirm with .

Alarm (Menu 7-2)

Use this menu to set the time for the alarm, then to turn it on or off. Increase and decrease the hours and minutes with and .

When the alarm rings, press any key; when asked “Switch on?” press to turn on the phone, or to leave it off.

Note: The alarm clearly stays in operation even with the phone switched off (you should remember this when travelling by airplane and the alarm might ring).

Date format (Menu 7-3)

This function sets the format of the date to the European system (days-months-year: menu 7-3-1) or American system (months-day-year: menu 7-3-2).

Information on the phone (Menu 8)

Personal number (Menu 8-1)

This function makes it possible to display your own phone number stored on the SIM card. If the number fails to appear or has to be changed, enter the number (or edit with) and confirm.

IMEI (Menu 8-2)

Displays the phone's serial number. If your phone gets stolen, communicate this number (printed on a label on the sales package – which should therefore be kept) to the network operator or service provider to block use of the phone on the GSM networks that provide this service.

Software (Menu 8-3)

Displays the phone's software release.

Information on the SIM card (Menu 8-4)

Displays, in succession, the phase (1 or 2) of the SIM followed by the country's code (MCC) and the GSM network code (MNC) on which the issuing operator operates.

Total life (Menu 8-5)

Displays the total time of the calls sent and received by the phone. This figure cannot be reset.

Security (Menu 9)**PIN (Menu 9-1)**

This function makes it possible, by changing PIN1 and PIN2, to personalize the PIN with 4-8 digits. If the SIM allows it, there is also the "Use PIN" option (9-1-3) to enable or disable the request for the PIN when switching on.

Phone (Menu 9-2)

Access to this submenu depends on correctly entering the security code set by the manufacturer as 000000.

On entering the security code number (shown as asterisks), confirmed with , there are the following options: "Type" (9-2-1) to turn on and off the request for the security code when switching on or to have the phone work with just one of the last 10 SIM cards inserted; "Delete List" (9-2-2) to delete the list of the last 10 SIM cards inserted; "New Code" (9-2-3) to change the code to access this menu; "Autoblock" (9-2-4) to turn automatic block on and off, changing the relevant code (factory setting 1 2 3). With the "Use default" option (9-2-5) all the factory settings are restored.

Call block (Menu 9-3)

This network service makes it possible to block "Outgoing calls" (in detail: all "Outgoing calls", calls "Abroad" and "Only domestic" calls) and "Incoming calls" (in detail: "Incoming calls" and calls "Abroad").

With the "Delete" option (9-3-3) it is possible to cancel the various types of call block set beforehand, after entering the security code and then pressing .

All attempts at activating call blocking depend on entering a 4-digit code, residing in the SIM card memory and therefore provided by the network operator.

With "New Code" (9-3-4) it is possible to enter a new code to access call blocking.



Fixed dialling numbers (Menu 9 4)

This function requires PIN2 and, after activation (9-4-1), it permits sending calls solely to the phone numbers contained in the fixed dialling number (FDN) memories. In addition, it permits calling phone numbers solely from these fixed dialling number memories.



Note: The FDN function numbers are stored solely on the SIM card and can only be changed with the PIN2 code.

Call divert (Menu 10)

Always divert (Menu 10-1)

This network service makes it possible to transfer incoming calls to another phone number. Before turning on call divert, it is necessary to enter the number on which to transfer calls. With   it is possible to divert calls according to the type of service: "All", "Voice", "Fax" and "Data".

Missed calls (Menu 10-2)

This network service makes it possible to transfer calls to which you cannot reply (if busy, cut off, no answer and all missed calls) according to the type of setting. Before turning on this function, it is necessary to enter the number on which to divert the calls: pressing   sends the network the request to display the service status.



Note: the "No answer" option has to contain the time after which transfer is turned on.

Cancel (Menu 10-3)

Cancels all diversions activated or the different types of diversion activated ("Always", "If busy", "If cut off", "No answer").

GSM networks (Menu 11)

Network search (Menu 11-1)







This function starts a search for GSM networks that can be received in the area, listing the ones found. This list also gives the status of each network marked by a symbol (📶 own network, ▲ roaming or ✖ prohibited network). Go onto the chosen network and confirm with   to start registering the phone.

Selection (Menu 11-2)

This function turns on "Automatic" or "Manual" GSM network selection.

Network list (Menu 11-3)

This function makes it possible to add GSM networks to the SIM card to create a priority list the phone will follow in searching for a GSM network when there is not the one that issued the SIM card.

Press   to scroll through the list of priorities in searching for a network. Use   to go onto "Empty" and press   to display the set networks that can be added to the priority list.

By holding down  it is possible to delete a network from the priority list.

Own network (Menu 11-4)

This function displays the name of the network operator that issued the SIM card.

Select Band (Menu 11-5)

This function makes it possible to select the frequency band - 900/1800MHz or 900/1900 MHz, so that the phone can operate in the European Union countries and in other countries that have implemented a GSM-compatible 1900 MHz network.

To select the band, enter the function, select the option and confirm with .



Internet (Menu 12)

Confirming this selection takes you to the WAP connection and the parameters for optimum management of this function. To use the associated functions in the best way, read the section, "Accessing the Internet", on page 54.

ACCESSORIES

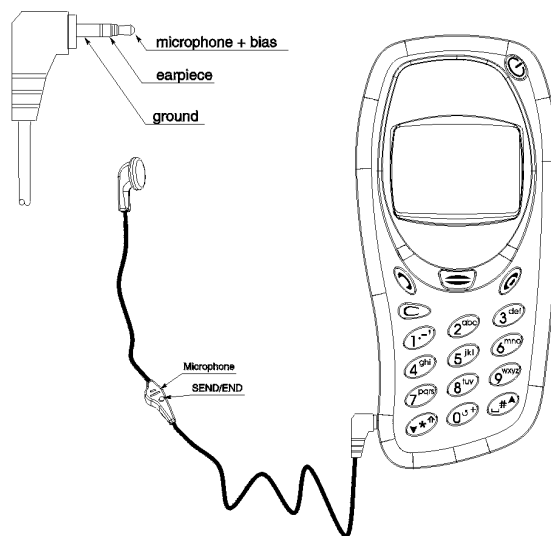

Connect the jack of the cable of the earphone (optional extra) into the socket on the side of the phone so it is fully inserted.





To answer a call with the earphone connected, press  **OK** (or briefly press the earphone key, if there is one); at the end of the call, press .

To disconnect the earphone from the phone, extract the jack from the socket

TROUBLESHOOTING

Problem	Possible cause and solution
It is not possible to switch on the phone.	Low battery charge. Recharge the battery. (Page 11) The battery is not connected correctly (page 9)
You hear an audible warning and this image appears: 	Low battery charge. The battery charger is not properly connected. Recharge the battery. (Page 10-11)
A blinking  symbol is displayed.	A problem has occurred during battery recharge. Check the battery and the charger plug are connected to the phone correctly. (Page 10-11)
While the phone is recharging the display shows this symbol 	A fault has occurred in the battery: charging temperature too high (take out the battery and leave it to cool for half an hour), damage (change the battery). Change the battery.
This message is displayed: "Insert SIM"	No card has been inserted in the phone or the card has not been inserted correctly. Insert the SIM card. (Page 8)
This message is displayed: "SIM faulty"	The SIM card is defective or has not been inserted correctly. Check that the SIM card has been inserted correctly and is clean. (Page 7-9)
This message is displayed: "PUK ►-----"	The wrong PIN has been keyed in 3 consecutive times. Unlock the SIM card with the 8-digit PUK code (Page 21).
The name of the network operator or service provider is not shown on the display in stand-by mode.	You are outside the area of coverage of the GSM signal. Change position.

Problem	Possible cause and solution
The symbol  is displayed and it is not possible to make calls.	The network operator or service provider that issued the SIM card you are using has no roaming arrangements with the GSM network to which your phone is now connected. Only emergency calls are possible. (Page 17)
You hear a three-tone warning during a call.	The GSM network is overloaded. Wait a moment and try again.
A blinking  symbol is displayed and no SMS messages are received.	The SMS memory is full: delete one or more SMS messages. (Page 49)
Weak signal ().	You are in an area with a weak GSM signal (e.g., in a building or a tunnel). Change position.
A few seconds after accessing menu 9 - Internet, an error message is displayed and there is no Internet connection.	Try connecting to the Internet later and with better radio signal reception conditions. If you still fail to connect to the Internet, check the Profile set-up in the "Internet" - "Settings" menu (12-2).
Instead of the network operator's normal logo, the display shows "X NET YY"	The phone is connected to a network that the SIM fails to recognize (for instance, a network set up after the SIM had been issued).

IMPORTANT

Read this information before using your wireless handheld phone

SAFETY INFORMATION**Exposure To Radio Frequency Signals**

Your wireless handheld portable telephone is a low power radio transmitter and receiver. When it is ON, it receives and also sends out radio frequency (RF) signals. In August 1996, the Federal Communications Commission (FCC) adopted RF exposure guidelines with safety levels for handheld wireless phones. Those guidelines are consistent with safety standards previously set by both U.S. and international standards bodies:

- American National Standards Institute (ANSI) IEEE C95.1-1992
- National Council on Radiation Protection and Measurement (NCRP) - Report 86
- International Commission on Non-Ionizing Radiation Protection (ICNIRP) 1996
- Department of Health and Welfare Canada, Safety Code 6

Those standards were based on comprehensive and periodic evaluations of the relevant scientific literature. For example, over 120 scientists, engineers, and physicians from universities, government health agencies, and industry reviewed the available body of research to develop the ANSI Standard (C95.1). The design of your phone complies with the FCC guidelines (and those standards).

If you wear a handset on your body, to maintain compliance with FCC RF exposure guidelines, use only approved carrying case, holster, or other body-worn accessory. If you do not use a body-worn accessory, ensure the antenna is at least one inch (2.5 centimeters) from your body when transmitting. Use of non-approved accessories may violate FCC RF exposure guidelines.

Antenna Care

Use only the supplied or an approved replacement antenna.

Unauthorized antennas, modifications, or attachments could damage the phone and may violate FCC regulations.

Phone Operation

Normal Operation

For the most efficient and comfortable use the phone as you would any other telephone, with the antenna pointed up and over your shoulder.

Tips on Efficient Operation

For your phone to operate most efficiently:

- Extend your antenna fully (if applicable).
- Do not touch the antenna unnecessarily when the phone is in use. Contact with the antenna affects call quality and may cause the phone to operate at a higher power level than otherwise needed.

Batteries

All batteries can cause property damage, injury or burns if a conductive material such as jewelry, keys or beaded chains touches exposed terminals. Exercise care in handling any charged battery, particularly when placing it inside your pocket, purse or other container with metal objects. When the battery is detached from the phone, your batteries are packed with a protective battery cover; please use this cover for storing your batteries when not in use.

Never throw a battery into a fire because it may explode. Since a leaking battery may corrode the telephone you need to replace it immediately with the same or equivalent type battery recommended by the manufacturer; otherwise, you risk damaging the phone, the charger or battery.

Driving

Check the laws and regulations on the use of wireless telephones in the areas where you drive and always obey them. Also, if using your phone while driving, please:

- give full attention to driving - driving safely is your first responsibility
- use hands-free operation, if available
- pull off the road and park before making or answering a call if driving conditions so require

Electronic Devices

Most modern electronic equipment is shielded from RF signals. However, certain electronic equipment may not be shielded against the RF signals from

your wireless phone.

Pacemakers

The Health Industry Manufacturers Association recommends that a minimum separation of six (6") inches (20 cm) be maintained between a handheld wireless phone and a pacemaker to avoid potential interference with the pacemaker. These recommendations are consistent with the independent research by and recommendations of Wireless Technology Research.

Persons with pacemakers:

- Should **always** keep the phone more than six inches from their pacemaker when the phone is turned ON.
- Should not carry the phone in a breast pocket.
- Should use the ear opposite the pacemaker to minimize the potential for interference.
- Should turn the phone off immediately if they have any reason to suspect that interference is taking place.

Hearing Aids

Some digital wireless phones may interfere with some hearing aids. In the event of such interference you may want to consult your hearing aid manufacturer or call the customer service line to discuss alternatives.

Other Medical Devices

If you use any other personal medical device, consult the manufacturer of your device to determine if they are adequately shielded from external RF energy. Your physician may be able to assist you in obtaining this information.

Turn your phone OFF in health care facilities when any regulations posted in these areas instruct you to do so. Hospitals or health care facilities may be using equipment that could be sensitive to external RF energy.

Posted facilities

Turn your phone OFF in any facility where posted notices so require.

Aircraft

FCC regulations prohibit using your phone while in the air. Switch OFF your phone before boarding an aircraft.

Blasting areas

To avoid interfering with blasting operations, turn your phone OFF when in a "blasting area" or in areas posted: "Turn off two way radio". Obey all signs and instructions.

Potentially explosive atmospheres

Turn your phone OFF and do not remove the battery when in any area with a potentially explosive atmosphere and obey all signs and instructions. Sparks in such areas could cause an explosion or fire resulting in bodily injury or even death. Areas with a potentially explosive atmosphere are often, but not always, clearly marked. They include fueling areas such as gasoline stations; below deck on boats; vehicles using liquefied petroleum gas; fuel or chemical transfer or storage facilities; areas where fuel odors are present; areas where the air contains chemicals or particles, such as grain, dust, or metal powders; any other area where you would normally be advised to turn off your vehicle engine.

Vehicles

RF signals may affect improperly installed or inadequately shielded electronic systems in motor vehicles that may include electronic fuel injection systems, electronic anti-skid (anti-lock) braking systems, electronic speed control systems, or air bag systems.

Check with the manufacturer or its representative regarding your vehicle. You should also consult the manufacturer of any equipment that has been added to your vehicle.

Vehicles equipped with an air bag

For vehicles equipped with an air bag, remember that an air bag inflates with great force. Do not place objects, including both installed or portable wireless equipment, in the area over the air bag or in the air bag deployment area. If in-vehicle wireless equipment is improperly installed and the air bag inflates, serious injury could result.

IMPORTANT NOTICES

- **Service stations:** It is recommended to switch off the phone when fuelling; the same precaution has to be taken when near petro-chemical plants or where explosives are used.
- **Keep the phone out of the reach of children.**
- **Use the phone while driving solely with a handsfree device. Do not stop on the hard shoulder of a motorway or dual carriageway to make or receive a phone call, unless it is an emergency. Breaching these regulations is cause for a fine under the highway code and may even be a crime.**
- **Switch the phone off on board an airplane: it may interfere with the aircraft's instrumentation. The user is obliged to ask a crew member for permission to use the phone while the plane is on the ground. Failure to observe this regulation is a crime in several countries.**
- **It is recommended not to use the phone in hospitals. Failure to observe this precaution may lead to severe liability, even of a penal nature. It is recommended to pay the utmost attention when using the phone in the field of interaction with devices such as pace-makers, hearing aids and electro-medical equipment in general. Cardiacs are advised not to keep a mobile phone near their heart to prevent any interaction between the electromagnetic waves and their heartbeat.**
- **There are no definite data on the possible harmfulness of electromagnetic waves generated by a mobile phone. In any case, exposure to electromagnetic waves can be drastically reduced by using a portable handsfree device or ear-phone.**
- **Use genuine parts and accessories only. using other components could damage the phone and forfeit warranty.**
- **Never attempt to dismantle the phone or battery: there are no parts the user can repair inside it.**
- **Prevent the phone coming into contact with any liquid: however, should this occur, disconnect the phone from the electricity supply (if being recharged) and call a technical service centre in compliance with the terms of the warranty certificate.**
- **Avoid using the phone outside the permissible temperature range: -10°C and + 55°C. Never leave the phone in direct sunlight or where there are high levels of humidity or dust.**
- **The phone can be cleaned by using a soft cloth moistened with water.**

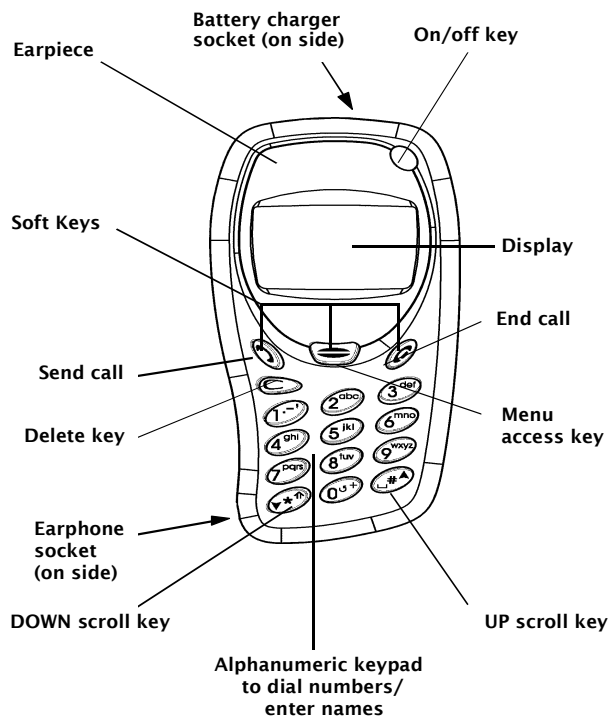

QUICK HELP

How to make your first call

Carefully read the instructions and information supplied by the network operator or service provider with the SIM card.



- ① Insert a valid SIM card into the phone when it is switched off.
- ② Insert the battery.
- ③ If necessary, charge the battery with the specific battery charger.

Note: The phone can be used while recharging, but this lengthens the recharge time.

- ④ Switch on the phone by holding down . If the display shows

PIN▶

key in the PIN provided together with the SIM card and press .

When the PIN is requested, press   to display the available languages; press  to send an **emergency call** (not available in all countries-contact the network operators for information).

(You should not misuse this service).



- ⑤ When the name of the network operator or service provider who supplied the SIM card appears, the display is on stand-by and the phone is connected to the network.
- ⑥ Key in the dialling code, then the phone number and press .

How to answer a call

- ① With the phone on and in an area covered by the GSM network, an incoming call is signalled by the ringer and the display shows:

<<CALL>>

Note: to switch off the ringer without rejecting the incoming call, press .

- ② Press  to answer and then  to end a call.

How to save a number to the phonebook

- ① With the display on stand-by, enter the phone number preceded by the local area code and the international code (with + instead of 00).

Note: the + symbol is displayed by holding down .

- ② Press  to reach the "Phonebook" menu and confirm with .
- ③ Enter the name and press .

Pressing the first time enters the first letter, the second time the next one and so on. To delete the last letter keyed in, briefly press .

- ④ Press and again to confirm the position in the phonebook.
- ⑤ Send the call to the number or delete the number by pressing .

How to retrieve a position from the phonebook















- ① With the display on stand-by press till "Phonebook" is displayed and confirm with .
- ② Scroll through the phonebook positions with and .
- ③ Press on the required phonebook position to send the call.

How to send an EMS message

- ① With the display on stand-by, press to reach "Messages" and confirm twice with .
- ② Press 3 times to go onto "Parameters" and confirm twice with .
- ③ Press and go onto "SMS Centre Number": enter the SMS Centre number supplied by the network operator or service provider) and press .
- ④ Hold down to return to the display on stand-by.
- ⑤ Press to go onto "Messages", confirm with and confirm again on "New".
- ⑥ With the request "Send to:" enter the recipient's phone number (or access the phonebook by pressing , choose a number with or and copy it to the EMS , then confirm with .
- ⑦ Compose the message and press .
- ⑧ Press with the request "Send": the SMS text message has been sent.

Note: The steps described in points ① ② ③ ④ are used solely to send the first SMS message.

How to reach the first SMS message

- ① The phone emits an audible warning and for a few seconds the display shows:
- ② Until the SMS message is read, the display on stand-by shows : press , to the "Messages" menu; the message received and never read will open automatically; scroll through it with  .
To read a message another time, go to the "Messages" menu with  and , go onto "Received" with   and confirm with .
- ③ Press   and  or  to scroll through the message.
- ④ Press   once to go back to the start of the message or twice to quit.

Note: Messages are recorded on the SIM card; so as not to use up its memory pointlessly, it is a good idea to delete SMS messages after reading them to leave room for fresh incoming SMS messages.