



# BlueMod+S50 Hardware User Guide

1VV0301505 Rev. 1 – 2018-03-12

**TELIT**  
TECHNICAL  
DOCUMENTATION

SPECIFICATIONS ARE SUBJECT TO CHANGE WITHOUT NOTICE

## **NOTICE**

While reasonable efforts have been made to assure the accuracy of this document, Telit assumes no liability resulting from any inaccuracies or omissions in this document, or from use of the information obtained herein. The information in this document has been carefully checked and is believed to be reliable. However, no responsibility is assumed for inaccuracies or omissions. Telit reserves the right to make changes to any products described herein and reserves the right to revise this document and to make changes from time to time in content hereof with no obligation to notify any person of revisions or changes. Telit does not assume any liability arising out of the application or use of any product, software, or circuit described herein; neither does it convey license under its patent rights or the rights of others.

It is possible that this publication may contain references to, or information about Telit products (machines and programs), programming, or services that are not announced in your country. Such references or information must not be construed to mean that Telit intends to announce such Telit products, programming, or services in your country.

## **COPYRIGHTS**

This instruction manual and the Telit products described in this instruction manual may be, include or describe copyrighted Telit material, such as computer programs stored in semiconductor memories or other media. Laws in the Italy and other countries preserve for Telit and its licensors certain exclusive rights for copyrighted material, including the exclusive right to copy, reproduce in any form, distribute and make derivative works of the copyrighted material. Accordingly, any copyrighted material of Telit and its licensors contained herein or in the Telit products described in this instruction manual may not be copied, reproduced, distributed, merged or modified in any manner without the express written permission of Telit. Furthermore, the purchase of Telit products shall not be deemed to grant either directly or by implication, estoppel, or otherwise, any license under the copyrights, patents or patent applications of Telit, as arises by operation of law in the sale of a product.

## **COMPUTER SOFTWARE COPYRIGHTS**

The Telit and 3rd Party supplied Software (SW) products described in this instruction manual may include copyrighted Telit and other 3rd Party supplied computer programs stored in semiconductor memories or other media. Laws in the Italy and other countries preserve for Telit and other 3rd Party supplied SW certain exclusive rights for copyrighted computer programs, including the exclusive right to copy or reproduce in any form the copyrighted computer program. Accordingly, any copyrighted Telit or other 3rd Party supplied SW computer programs contained in the Telit products described in this instruction manual may not be copied (reverse engineered) or reproduced in any manner without the express written permission of Telit or the 3rd Party SW supplier. Furthermore, the purchase of Telit products shall not be deemed to grant either directly or by implication, estoppel, or otherwise, any license under the copyrights, patents or patent applications of Telit or other 3rd Party supplied SW, except for the normal non-exclusive, royalty free license to use that arises by operation of law in the sale of a product.

## USAGE AND DISCLOSURE RESTRICTIONS

### I. License Agreements

The software described in this document is the property of Telit and its licensors. It is furnished by express license agreement only and may be used only in accordance with the terms of such an agreement.

### II. Copyrighted Materials

Software and documentation are copyrighted materials. Making unauthorized copies is prohibited by law. No part of the software or documentation may be reproduced, transmitted, transcribed, stored in a retrieval system, or translated into any language or computer language, in any form or by any means, without prior written permission of Telit.

### III. High Risk Materials

Components, units, or third-party products used in the product described herein are NOT fault-tolerant and are NOT designed, manufactured, or intended for use as on-line control equipment in the following hazardous environments requiring fail-safe controls: the operation of Nuclear Facilities, Aircraft Navigation or Aircraft Communication Systems, Air Traffic Control, Life Support, or Weapons Systems (High Risk Activities"). Telit and its supplier(s) specifically disclaim any expressed or implied warranty of fitness for such High Risk Activities.

### IV. Trademarks

TELIT and the Stylized T Logo are registered in Trademark Office. All other product or service names are the property of their respective owners.

### V. Third Party Rights

The software may include Third Party Right software. In this case you agree to comply with all terms and conditions imposed on you in respect of such separate software. In addition to Third Party Terms, the disclaimer of warranty and limitation of liability provisions in this License shall apply to the Third Party Right software.

TELIT HEREBY DISCLAIMS ANY AND ALL WARRANTIES EXPRESS OR IMPLIED FROM ANY THIRD PARTIES REGARDING ANY SEPARATE FILES, ANY THIRD PARTY MATERIALS INCLUDED IN THE SOFTWARE, ANY THIRD PARTY MATERIALS FROM WHICH THE SOFTWARE IS DERIVED (COLLECTIVELY "OTHER CODE"), AND THE USE OF ANY OR ALL THE OTHER CODE IN CONNECTION WITH THE SOFTWARE, INCLUDING (WITHOUT LIMITATION) ANY WARRANTIES OF SATISFACTORY QUALITY OR FITNESS FOR A PARTICULAR PURPOSE.

NO THIRD PARTY LICENSORS OF OTHER CODE SHALL HAVE ANY LIABILITY FOR ANY DIRECT, INDIRECT, INCIDENTAL, SPECIAL, EXEMPLARY, OR CONSEQUENTIAL DAMAGES (INCLUDING WITHOUT LIMITATION LOST PROFITS), HOWEVER CAUSED AND WHETHER MADE UNDER CONTRACT, TORT OR OTHER LEGAL THEORY, ARISING IN ANY WAY OUT OF THE USE OR DISTRIBUTION OF THE OTHER CODE OR THE EXERCISE OF ANY RIGHTS GRANTED UNDER EITHER OR BOTH THIS LICENSE AND THE LEGAL TERMS APPLICABLE TO ANY SEPARATE FILES, EVEN IF ADVISED OF THE POSSIBILITY OF SUCH DAMAGES.

## APPLICABILITY TABLE

### PRODUCTS

■ ■ BLUEMOD+S50/AI/CEN

■ ■ BLUEMOD+S50/AP/CEN

## CONTENTS

<b>1.</b>	<b>INTRODUCTION .....</b>	<b>7</b>
1.1.	Scope .....	7
1.2.	Audience .....	7
1.3.	Contact Information, Support.....	7
1.4.	Text Conventions .....	8
1.5.	Related Documents .....	8
<b>2.</b>	<b>OVERVIEW .....</b>	<b>9</b>
<b>3.</b>	<b>GENERAL PRODUCT DESCRIPTION .....</b>	<b>10</b>
3.1.	Feature Summary.....	10
3.2.	Applications .....	11
3.3.	Block Diagram .....	12
<b>4.</b>	<b>APPLICATION INTERFACE .....</b>	<b>13</b>
4.1.	Power Supply .....	13
4.2.	Reset.....	14
4.3.	Serial Interface .....	15
4.4.	General Purpose I/O (GPIO) .....	19
4.5.	I <sup>2</sup> C Interface .....	19
4.6.	SPI Serial Peripheral Interface .....	19
4.7.	Serial Wire Debug Interface.....	20
4.8.	Test Mode .....	20
4.9.	NFC Function .....	21
4.10.	Slow Clock Interface.....	22
4.11.	Analog/Digital Converter (ADC) .....	23
<b>5.</b>	<b>MODULE PINS.....</b>	<b>24</b>
5.1.	Pin Numbering.....	24
5.2.	Pin Description .....	25
5.3.	Firmware depend Functions .....	26
5.4.	Handling of Unused Signals .....	26
<b>6.</b>	<b>ELECTRICAL CHARACTERISTICS .....</b>	<b>27</b>
6.1.	Absolute Maximum Ratings .....	27
6.2.	Operating Conditions.....	27
6.3.	DC Parameter .....	28
6.4.	Power Consumption and Power-Down Modes.....	29
6.5.	RF Performance .....	30

6.6.	Antenna-Gain and Radiation Pattern for BlueMod+S50/AI .....	31
<b>7.</b>	<b>MECHANICAL CHARACTERISTICS .....</b>	<b>33</b>
7.1.	Dimensions .....	33
7.2.	Recommended Land Pattern .....	33
7.3.	Re-flow Temperature-Time Profile .....	34
7.4.	AI Layout and Placement Recommendation .....	35
7.5.	OEM Layout and Antenna Selection in Respect to RED/FCC/IC Certification .....	36
7.6.	Housing Guidelines .....	38
7.7.	Safety Guidelines .....	38
7.8.	Cleaning .....	39
<b>8.</b>	<b>APPLICATION DIAGRAM.....</b>	<b>39</b>
<b>9.</b>	<b>COMPLIANCES .....</b>	<b>40</b>
9.1.	Declaration of Conformity CE .....	40
9.2.	FCC Compliance .....	41
9.3.	IC Compliance.....	43
9.4.	Bluetooth Qualification.....	45
9.5.	RoHS Declaration.....	45
<b>10.</b>	<b>PACKING .....</b>	<b>46</b>
10.1.	Tape&Reel Packing.....	46
10.2.	Tray Packing .....	48
10.3.	Moisture Sensitivity Level .....	48
<b>11.</b>	<b>EVALUATION KIT.....</b>	<b>49</b>
<b>12.</b>	<b>SAFETY RECOMMENDATIONS.....</b>	<b>50</b>
<b>13.</b>	<b>ACRONYMS.....</b>	<b>51</b>
<b>14.</b>	<b>DOCUMENT HISTORY .....</b>	<b>52</b>

## 1. INTRODUCTION

### 1.1. Scope

This document provides information how the BlueMod+S50 can be integrated into customer systems. It addresses hardware specifications of the BlueMod+S50 and requirements of the hardware environments for the BlueMod+S50.

---



The description text “BlueMod+S50” refers to all modules listed in the Applicability Table.

---

### 1.2. Audience

This document is intended for Telit customers, especially system integrators, about to implement Bluetooth modules in their application.

### 1.3. Contact Information, Support

For general contact, technical support services, technical questions and report documentation errors contact Telit Technical Support at:

- TS-SRD@telit.com  
or your local support center
- TS-EMEA@telit.com
- TS-AMERICAS@telit.com
- TS-APAC@telit.com

Alternatively, use:

<https://www.telit.com/contact-us/>

For detailed information about where you can buy the Telit modules or for recommendations on accessories and components visit:

<https://www.telit.com/>

Our aim is to make this guide as helpful as possible. Keep us informed of your comments and suggestions for improvements.

Telit appreciates feedback from the users of our information.

## 1.4. Text Conventions

---



Danger – This information **MUST** be followed or catastrophic equipment failure or bodily injury may occur.

---

---



Caution or Warning – Alerts the user to important points about integrating the module, if these points are not followed, the module and end user equipment may fail or malfunction.

---

---



Tip or Information – Provides advice and suggestions that may be useful when integrating the module.

---

All dates are in ISO 8601 format, i.e. YYYY-MM-DD.

## 1.5. Related Documents

- [1] Bluetooth SIG Core SpecificationV5.0
- [2] UICP\_UART\_Interface\_Control\_Protocol, 30507ST10756A
- [3] BlueMod+S50 AT Command Reference, 80578ST10890A
- [4] BlueMod+S50 Software User Guide, 1VV0301506
- [5] BlueEva+S50 Evaluation Kit User Guide, 1VV03xxxxx
- [6] BlueMod+S50 Testmode Reference, 80587NT1xxxxA
- [7] OTA Measurement User Guide, 1VV03xxxxx
- [8] Nordic: nRF52\_Series\_Reference\_Manual
- [9] Nordic: nRF52832\_PS v1.x.pdf (Product Specification)



## 2. OVERVIEW

This document provides information how the BlueMod+S50 can be integrated into customer systems. It addresses hardware specifications of the BlueMod+S50 and requirements of the hardware environments for the BlueMod+S50.



The term BlueMod+S50 is used as an abbreviation and refers to both, the BlueMod+S50/AI and the BlueMod+S50/AP.

If information is related to dedicated versions, the whole product name is used.

---

The BlueMod+S50 is delivered in two different hardware versions:

- BlueMod+S50/AI: with integrated bluetooth antenna
- BlueMod+S50/AP: without integrated bluetooth antenna and with a 50Ω rf connection on pin.



The integration of the BlueMod+S50 bluetooth module within user application shall be done according to the design rules described in this manual.

---

The information presented in this document is believed to be accurate and reliable. However, no responsibility is assumed by Telit Communications S.p.A. for its use, nor any infringement of patents or other rights of third parties which may result from its use. No license is granted by implication or otherwise under any patent rights of Telit Communications S.p.A. other than for circuitry embodied in Telit products. This document is subject to change without notice.

### 3. GENERAL PRODUCT DESCRIPTION

#### 3.1. Feature Summary

- Supports Bluetooth low energy
- Qualified Bluetooth V5.0 Single Mode LE
- Supports 2 Msym/s PHY for LE
- Arm® Cortex™-M4F core for embedded profiles or application software
- RF output power -20 up to +4dBm
- RF output power -40dBm in Whisper Mode
- Supply voltage range 1,7V to 3,6V
- Internal crystal oscillator (32 MHz)
- LGA Surface Mount type. BlueMod+S50: 17 x 10 x 2.6 mm<sup>3</sup>
- Pin compatible to Telit BlueMod family +S, +S42, +S42M and +SR
- Flexible Power Management
- NFC peripheral communication signal interface type A with 106 kbps bit rate
- High-speed UART interface
- I2C Master
- SPI Master/Slave interface
- Up to 19 digital IO's for individual usage by embedded software
- Up to 8 analog inputs for individual usage by embedded software
- 8/9/10/12bit ADC
- Low power comparator
- Real Time Counter
- 128-bit AES encryption
- CE certified
- Shielded to be compliant to optional FCC full modular approval
- Manufactured in conformance with RoHS2
- Operating temperature -40 ... +85 °C
- Weight: 0,7 g

## 3.2. Applications

The BlueMod+S50 is designed to be used in low power applications, like sensor devices. Some typical applications are described in this chapter.

Supported profiles are:

- Terminal I/O
- GATT based LE-profiles



Support for any additional profile is possible on request.

---

### 3.2.1. General Cable Replacement

In case there is no standardized application specific profile available the BlueMod+S50 offers Telit's Terminal I/O profile, which allows transparent data transfer over UART and supports Secure Simple Pairing, making the pairing process easy and the connection secure. Terminal I/O is available for iOS and Android as well as implemented in Telit's dual mode module BlueMod+SR.

### 3.2.2. Industry

BlueMod+S50 can be used to monitor and control motors, actuators, valves and entire processes.

### 3.2.3. POS/Advertising

BlueMod+S50 supports iBeacon or similar applications.

### 3.2.4. Healthcare and Medical

Usage of Bluetooth is aimed mainly at devices that are used for monitoring vital data. Typical devices are blood glucose meter, blood pressure cuffs and pulse ox meters. Bluetooth BR/EDR and low energy were chosen by the Continua Health Alliance as transports for interoperable end to end communication.

### 3.2.5. Sports and Fitness

In the sports and fitness segment the BlueMod+S50 is used in devices for positioning as well as monitoring vital data. Typical devices in this market are heart rate monitors, body temperature thermometers, pedometers, cadence meters, altimeter, positioning / GPS tracking and watches displaying information from sensors.

### 3.2.6. Entertainment

Bluetooth technology is already used in a wide variety of devices in the entertainment sector, namely set-top boxes / gaming consoles. BlueMod+S50 is especially suited for use in remote controls, gaming controller and wireless mouse/keyboard applications.

### 3.3. Block Diagram

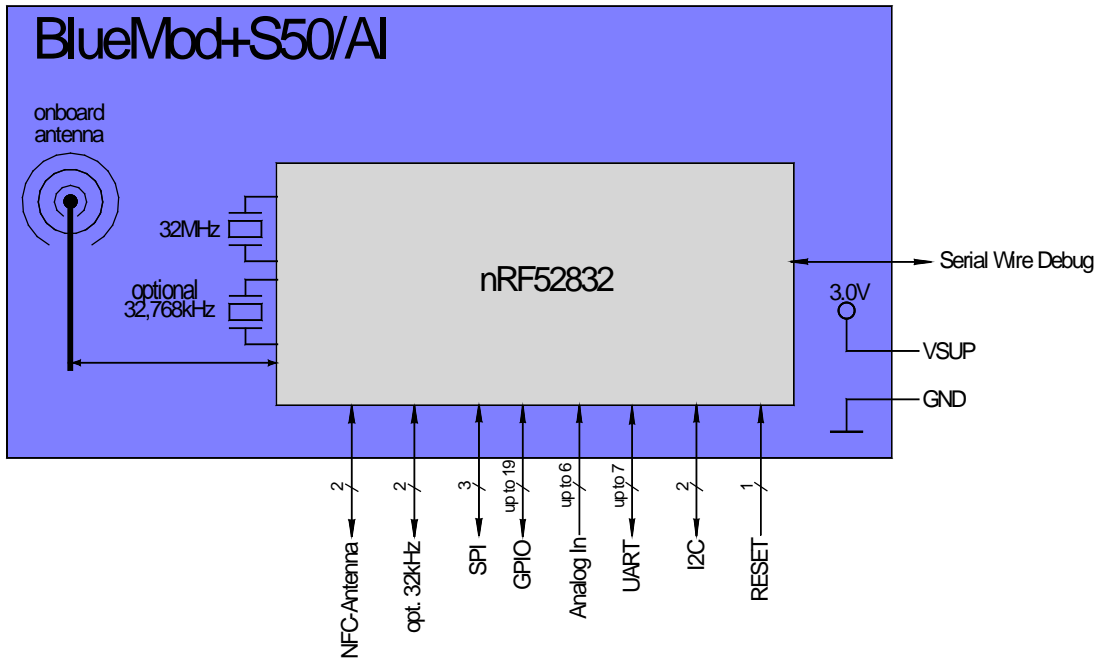

Figure 1: BlueMod+S50/AI Block Diagram

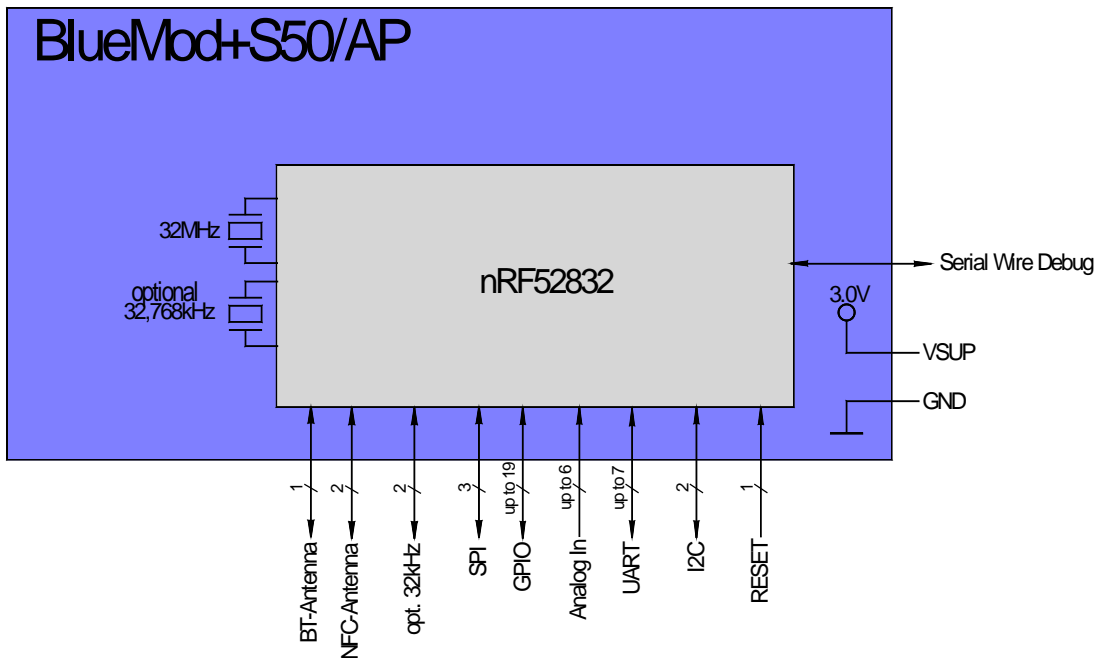

Figure 2: BlueMod+S50/AP Block Diagram

## 4. APPLICATION INTERFACE

### 4.1. Power Supply

BlueMod+S50 require a power supply with the following characteristics:

Typical: 3,0V<sub>DC</sub>, min.: 1,7V<sub>DC</sub>, max.: 3,6V<sub>DC</sub>, thereby delivering > 25 mA peak

BlueMod+S50 is designed to be powered from 3V coin cell batteries e.g. CR2032 directly, or any other power source complying with the given requirements. For optimal performance, a stable supply is recommended. Furthermore, it is recommended to place a capacitor in parallel to the CR2032 3V coin cell battery in order to prolong battery lifetime, by compensating the effects of the rising source resistance of the battery to pulsed loads. Since the isolation resistance of this capacitor will discharge the battery in a not insignificant scale, the capacitor should be chosen under consideration of the following rules:

- capacitance as small as necessary
- nominal voltage as high as possible
- case size as large as possible
- use X7R instead of X5R

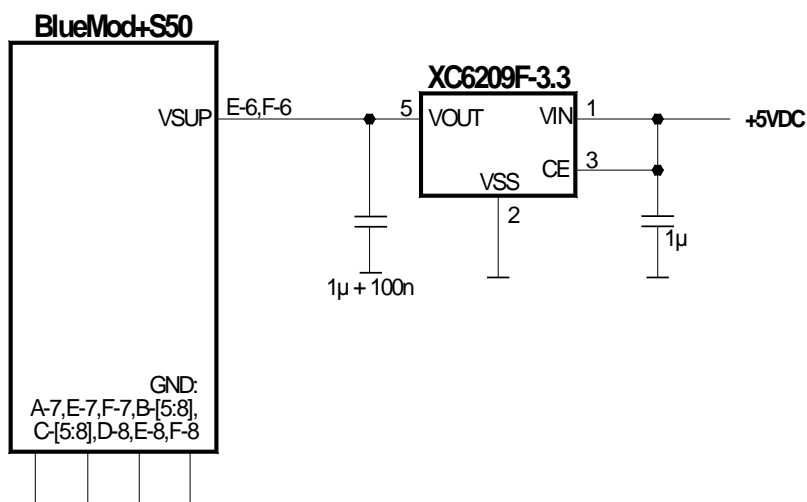

Figure 3: BlueMod+S50 Example Power Supply with LDO

**It is strongly recommended NOT to switch the module power supply on/off while other parts of the circuitry stay powered. This mostly leads to hardly controllable back-feeding issues.**



Due to the ultra-low power design a few  $\mu$ Amps are enough to raise VSUP to an undefined state, which may cause a hang-up deadlock if power is switched on again.

Any I/O pin at a voltage > 0,3V while the supply VSUP is at 0V violates the abs. max. ratings given in chapter 5.1 Absolute Maximum Ratings.

It is instead recommended to use the advanced power management features, which may reduce the supply current to 300nA.

## 4.2. Reset

BlueMod+S50 are equipped with circuitry for generating reset from two sources:

- A reset is held active, when VSUP falls below the threshold of the brownout detector ( $V_{BOR} = 1,2V \dots 1,7V$ ), and is released when VSUP rises above  $V_{BOR} + V_{HYST}$ . The brownout detector also holds the reset active during power up, until  $VSUP > V_{BOR}$ .
- A reset is generated, when VSUP is  $> V_{BOR}$  and increases 300 mV or more, within 300 ms or less.
- By holding pin B-1 (EXT-RES#) at  $\leq VSUP * 0,25V$  for  $t_{HOLDRESETNORMAL} \geq 0,2\mu s$ , an external reset (*pin reset*) is generated. This pin has a fixed internal pull-up resistor ( $R_{PU} = 11k\Omega \dots 16k\Omega$ ). EXT-RES# may be left open if not used.

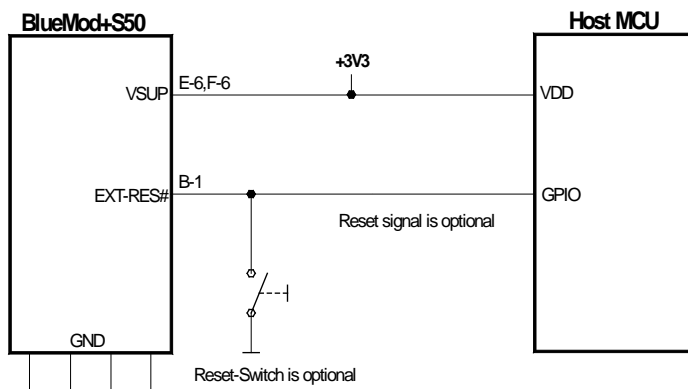

Please Note: EXT-RES# of BlueMod+S50 has approx. 13k internal pullup.

Figure 4: BlueMod+S50 Example Reset

The following table shows the pin states of BlueMod+S50 during reset active. This pin states are kept until hardware initialization has started.

Pin Name	State: BlueMod+S50
EXT-RES#	Input with pull-up <sup>(1)</sup>
XL-IN	Input floating (disconnected)
XL-OUT	Input floating (disconnected)
UART-TXD	Input floating (disconnected)
UART-RXD	Input floating (disconnected)
UART-RTS#	Input floating (disconnected) with pull-up resistor 470k $\Omega$ <sup>(2)</sup>
UART-CTS#	Input floating (disconnected)
IUR-OUT#	Input floating (disconnected)
IUR-IN#	Input floating (disconnected)
GPIO[0:14]	Input floating (disconnected)
TESTMODE#	Input floating (disconnected)
BOOT0	Input floating (disconnected)
SWDIO	Input with pull-up <sup>(1)</sup>
SWCLK	Input with pull-down <sup>(1)</sup>

<sup>(1)</sup> pull-up, pull-down:  $R_{PU}, R_{PD}$  is typ. 10k $\Omega$

Table 1: Pin States during Reset

### 4.3. Serial Interface

The serial interface of BlueMod+S50 is a high-speed UART interface supporting RTS/CTS flow control and interface-up/down mechanism according to the UICP protocol (refer to [2]).

- Electrical interfacing is at CMOS levels (defined by VSUP; see chapter 6.3.1)
- Transmission speeds are 9600 – 921600 bps and 1Mbps (asynchronous)
- Character representation: 8 Bit, no parity, 1 stop bit (8N1)
- Hardware flow-control with RTS and CTS (active low)



Transmission speed may be limited by firmware. See corresponding AT command reference [3] for further information.

#### 4.3.1. Basic Serial Interface

The basic serial interface (with RTS/CTS flow control) uses only four signal lines (UART-RXD, UART-TXD, UART-CTS#, UART-RTS#) and GND. IUR-IN# and IUR-OUT# (see below) can be left unconnected.

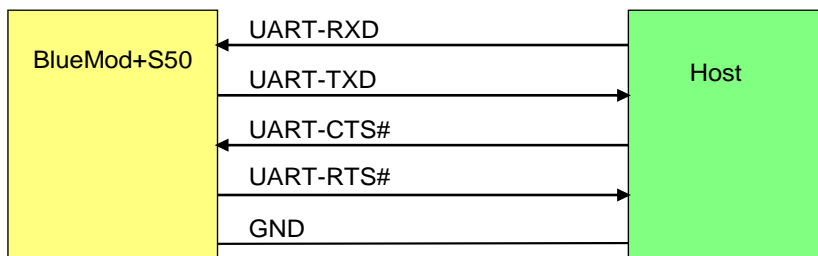

Figure 5: Basic Serial Interface



#### **A pulldown resistor is programmed to CTS# if UICP is disabled.**

If AT+SYSTEMOFF is issued while UICP is disabled, it is necessary that the host keeps CTS# at logic low or leaves this pin floating.

Otherwise the supply current drawn in the deep sleep mode increases by  $VSUP/13k\Omega$ , which would be at 3V 231 $\mu$ A, 770 times the expected 0,3 $\mu$ A. This would reduce the life time of a coin cell significantly.

### 4.3.2. 4-Wire Serial Interface

If the host in question is sufficiently fast, a four-wire scheme may be successful. Connect the serial lines UART-RXD, UART-TXD as well as UART-RTS# and GND; leave UART-CTS# open. The host is required to stop sending data within a short time after de-assertion of UART-RTS# (there is room for up to 4 more characters at the time RTS# drops).

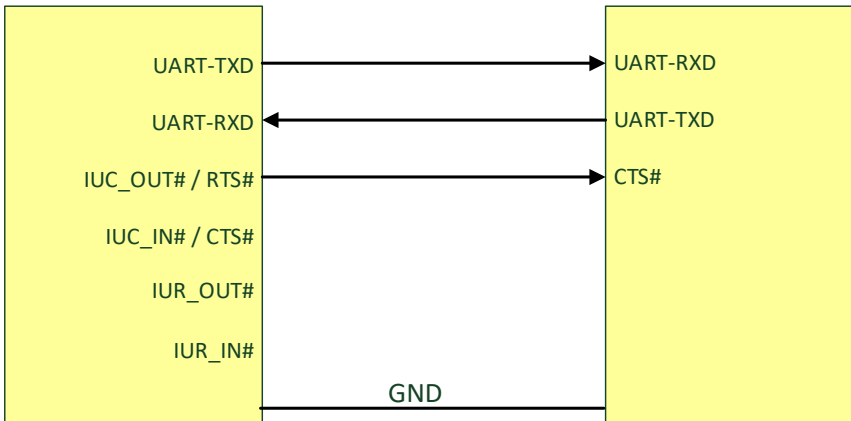

Figure 6: UART Interface without UICP Signals 4-wire (incl. GND)



UICP has to be deactivated permanently in this configuration, because signal UART-CTS# and IUR-IN# become inputs with no PU or PD if UICP is active. This would cause floating CMOS inputs.



It is strongly recommended to use hardware flow control in both directions. Not using flow control can cause a loss of data.

### 4.3.3. Serial Interface with UICP

A substantially saving of power during idle phases can be achieved (see when the UICP protocol is used (refer to [2])). This protocol should be implemented on the host side as well. Signals IUR-IN# and IUR-OUT# should be connected to the host and may be mapped to DSR and DTR, if an RS232-style (DTE-type) interface is used (see Figure 7).

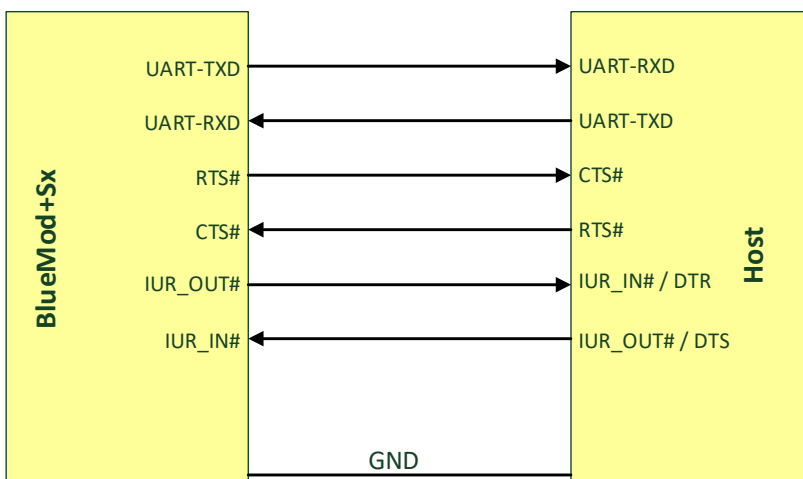

Figure 7: BlueMod+S50 Serial Interface Supporting UICP



If I/O line availability at the host side is extremely tight, 2 I/O lines could be saved by using the following scheme. This would come at the cost of

- The host is not allowed to enter sleep mode.
- The host must accept incoming data at all times and is not able to stop the BlueMod+Sx sending data. This may be difficult to control for all scenarios and adds the risk that data gets lost.
- The host doesn't implement UICP, but wake-up BT via GPIO.

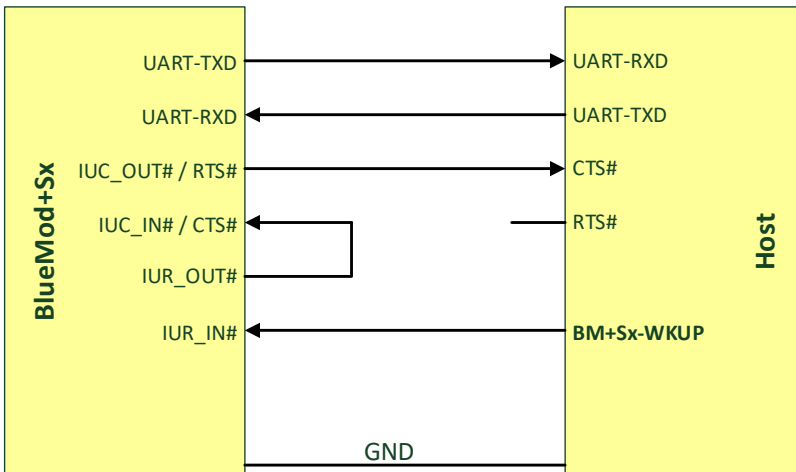

Figure 8: Five Wire Interface supporting UICP

#### 4.3.4. Dynamic I/O Signal Type Changes Depending on UICP Status

In order to reduce current consumption when using UICP, the BlueMod+S50 FW supports the following dynamic I/O signal type changes depending on the UICP activated resp. deactivated status.

Signal	UICP deactivated	UICP activated
UART-CTS#	I-PD	I-FLOAT
IUR-IN#	I-DIS	I-FLOAT
IUR-OUT#	I-DIS	O-PP

<sup>(1)</sup> I-PU: input pull-up; I-PD: input pull-down; I-FLOAT: input floating; I-DIS: input disconnected; O-PP: output push-pull

Table 2: Pin Assignments

Signal types I-PD, I-DIS and O-PP may be left open. I-FLOAT has to be driven to GND or VCC to avoid open CMOS input oscillation.

If UICP is deactivated the pull-down resistor on UART-CTS# helps to keep the serial interface active if UART-CTS# is open.

If UICP is active and the serial interface is down, UART-CTS# has to be held at VCC and thus the pull-down would cause an unwanted permanent current drain. Therefore, the pull-down is switched off in this mode.

4.3.5. UART Example Circuits

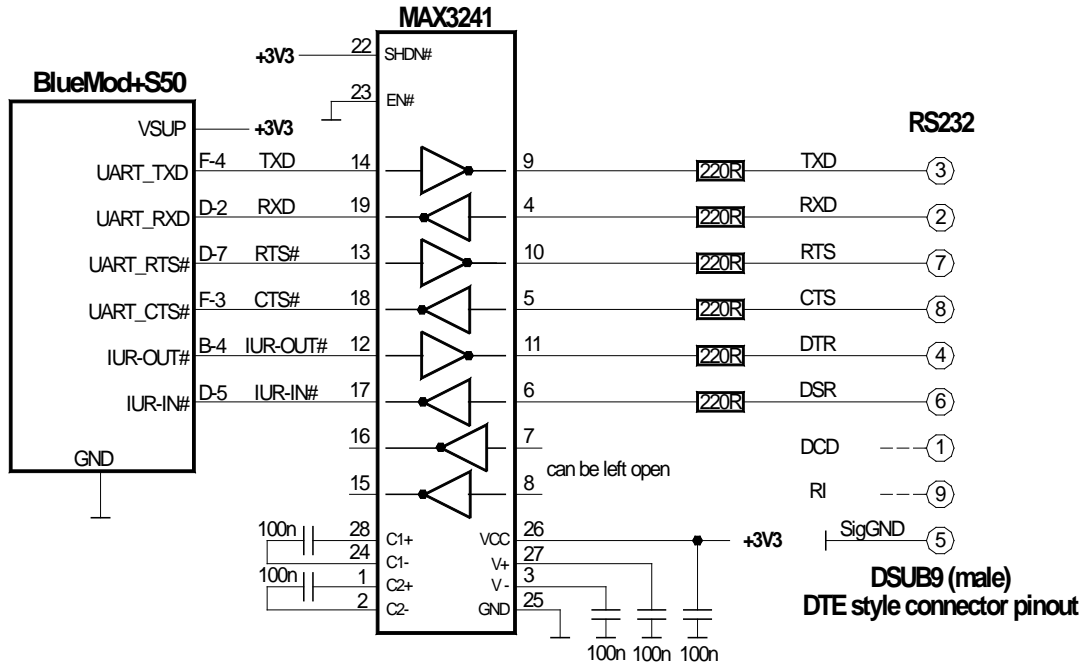

Figure 9: BlueMod+S50 Serial Interface (RS-232 COM Port) Supporting UICP

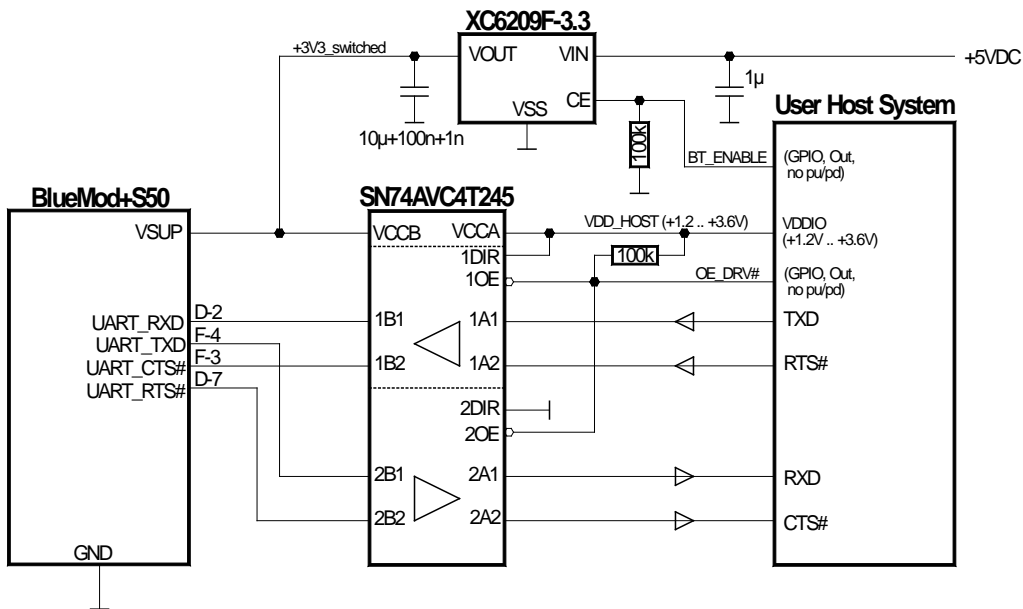

Figure 10: BlueMod+S50 Example Serial Interface (Mixed Signal Level)

#### 4.4. General Purpose I/O (GPIO)

Functionality is defined project specific in the firmware used.

It is possible to use the programmable digital I/Os GPIO[0:14] on the BlueMod+S50. Unused GPIO pins shall be left unconnected to stay compatible. There may be functions assigned to some in future versions of the firmware. Refer to 5.3

#### 4.5. I<sup>2</sup>C Interface

Functionality is defined project specific in the firmware used.

The I<sup>2</sup>C bus interface serves as an interface between the internal microcontroller and the serial I<sup>2</sup>C bus. BlueMod+S50 is the master and controls all I<sup>2</sup>C bus specific sequencing, protocol and timing. It supports standard (100kHz) and fast (400kHz) speed modes. The BlueMod+S50 as an I<sup>2</sup>C master must be the only master of the I<sup>2</sup>C bus (no *multimaster* capability). Clock stretching is supported.

SDA and SCL can be used to form an I<sup>2</sup>C interface. It is required to connect 4k7 pull-up resistors on SCL and SDA when this interface is used.

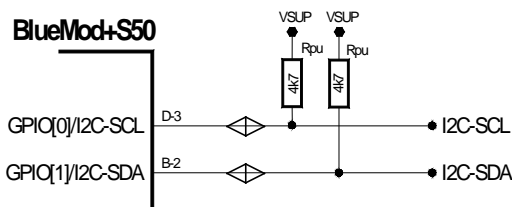

Figure 11: BlueMod+S50 I<sup>2</sup>C Interface

#### 4.6. SPI Serial Peripheral Interface

Functionality is defined project specific in the firmware used.

The serial peripheral interface (SPI) allows for full-duplex, synchronous, serial communication with external devices. The interface can be configured as the master and then provides the communication clock (SCK) to the external slave device(s), or as the slave. The SPI Interface supports SPI-modes 0 through 3. Module pins are used as follows:

- GPIO[2]: SPI-MOSI
- GPIO[5]: SPI-MISO
- GPIO[8]: SPI-SCK

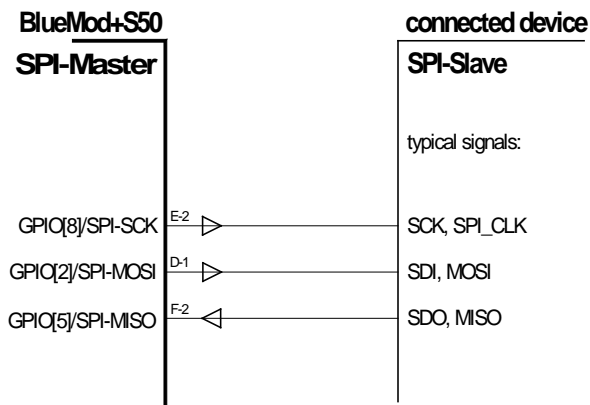

Figure 12: BlueMod+S50 SPI Interface (Example: Master Mode)

## 4.7. Serial Wire Debug Interface

The Serial Wire Debug (SWD) interface (signals SWDIO, SWCLK) is normally not used in a customer's product. It is reserved for debugging purposes.

Leave SWDIO, SWCLK unconnected. Only if you intend to use them for debugging purposes, make them available.

## 4.8. Test Mode

For regulatory approval purposes, the ability of test mode operation like "BlueMod+S50 Testmode" or "Direct two wire UART Testmode" (DTM) is mandatory. The Direct Test Mode (as defined by the Bluetooth SIG) and BlueMod+S50 Testmode are part of the BlueMod+S50 firmware. Please refer to [6] & [7].

For enabling the different test modes the BlueMod+S50 provides two IO pins.

- The pin Testmode is low active. Active means connect to GND.
- The pin Boot0 is high active. Active means connect to VSUP.
- The other two combinations start the bootloader for firmware update of the programmed firmware. These two modes are not scope of this document.

Table 3 shows the possible combinations:

Testmode#	Boot0	Mode
Active	Inactive	Testmode
Active	Active	DTM
Inactive	Active	Bootloader
Inactive	Inactive	Firmware

*Table 3: Testmode# / Boot0 Logic*

To enter and use the test modes, access to the following signals is required:

- BOOT0
- TESTMODE#
- UART-RXD
- UART-TXD
- UART-RTS#
- UART-CTS#
- GND

These pins shall be routed to some test pads on an outer layer, but can be left open during normal operation when not used.



Please note the UART is required for operation of DTM. For any regulatory approval, UART-RXD, UART-TXD, UART-RTS# and UART-CTS# must be freely accessible.

## 4.9. NFC Function

Functionality is defined project specific in the firmware used.

The NFCT peripheral supports communication signal interface type A and 106 kbps bit rate from the NFC Forum. With appropriate software, the NFC peripheral can be used to emulate the listening device NFC-A as specified by the NFC Forum.

Main features for the NFC peripheral:

- NFC-A listen mode operation
- 13.56 MHz input frequency
- Bit rate 106 kbps
- Wake-on-field low power field detection (SENSE) mode
- Frame assemble and disassemble for the NFC-A frames
- Programmable frame timing controller
- Integrated automatic collision resolution, CRC and parity functions

### 4.9.1. NFCT Antenna Recommendations

The NFCT antenna coil must be connected differential between NFCANT1 and NFCANT2 pins of BlueMod+S50.

Two external capacitors  $C_{tune1/2}$  connected between the NFCANTx pins and GND should be used to tune the resonance of the antenna circuit to 13.56 MHz.

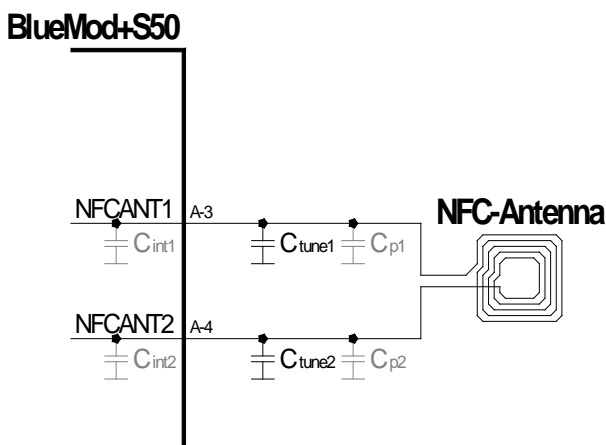

Figure 13: BlueMod+S50 NFC Antenna Tuning

$$C_{tune} = \frac{2}{(2\pi \times 13,56MHz)^2 \times L_{ant}} - C_p - C_{int}$$

$$C_{tune} = C_{tune1} = C_{tune2}$$

$$C_p = C_{p1} = C_{p2} \text{ (antenna track capacitance)}$$

$$C_{int} = C_{int1} = C_{int2} = 4pF$$

### 4.9.2. Power Back Feeding

If the NFC antenna is exposed to a strong NFC field, power back feeding may occur. That means, current may flow in the opposite direction on the supply due to parasitic diodes and ESD structures.

If a battery is used that does not tolerate return current, a series diode must be placed between the battery and the BlueMod+S50 in order to protect the battery. An ultra-low forward voltage schottky diode should be chosen to keep the battery life reduction as small as possible.

## 4.10. Slow Clock Interface

Even though an external slow clock is not required for BLE operation, consumption of power during power-down modes can be reduced by connecting an XTAL (32,768kHz) and two capacitors C1, C2 at pins XL-IN and XL-OUT.

Symbol	Item	Condition	Limit			Unit
			Min	Typ	Max	
f <sub>NOM</sub>	Crystal Frequency	T <sub>amb</sub> = 25°C		32,768		kHz
f <sub>TOL</sub>	Frequency Tolerance for BLE applications	including temperature and aging <sup>(1)</sup>			+/-250	ppm
C <sub>L</sub>	Load Capacitance				12,5	pF
C <sub>0</sub>	Shunt Capacitance				2	pF
R <sub>S</sub>	Equivalent Series Resistance				100	kΩ
P <sub>D</sub>	Drive Level				1	μW
C <sub>pin</sub>	Input Cap. On XL-IN and XL-OUT			4		pF

<sup>(1)</sup> adjust crystal frequency by choosing correct value for C1, C2 (value depends on CL of crystal and layout)

**Table 4: 32,768kHz Crystal Oscillator**

The module's firmware will detect the presence of a slow clock during the boot process and switch behavior appropriately.

### 4.10.1. Connection of an External 32,768 kHz Crystal

Connect the 32,768 kHz crystal and two capacitors C1, C2 at pins A-6 (XL-IN) and A-5 (XL-OUT). The exact value of C1 and C2 depends on the crystal and the stray capacitance of the layout. Select C1, C2 such that the slow clock oscillator operates at the exact frequency at room temperature (25°C). C1 and C2 shall be of equal capacity. The crystal and the capacitors shall be located as close as possible to pins A-5, A-6.

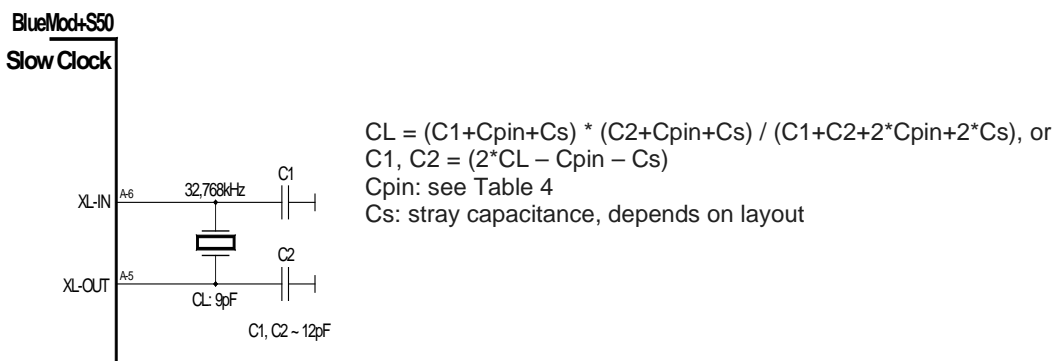

**Figure 14: BlueMod+S50 connection of external XTAL**

#### 4.11. Analog/Digital Converter (ADC)

Functionality is defined project specific in the firmware used.

The ADC supports

- 8/10/12-bit resolution, 14-bit resolution with oversampling
- full swing operation 0V to VSUP
- and up to 200kHz sample rate
- Limit event monitoring
- 2 sources for ADC reference voltage 600mV REF or VSUP/4
- Prescaler [1/6, 1/5, 1/4, 1/3, 1/2, 1, 2, 4]

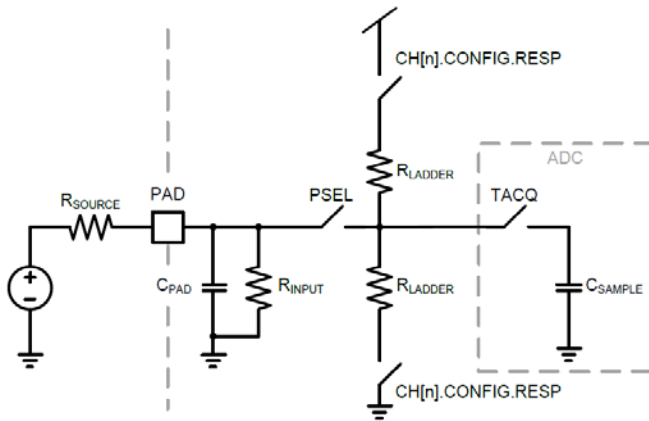

Figure 15: ADC Signal Input Structure

The ADC signal conversion is splitted into 2 phases, sample and convert. In the sampling phase the capacitor CSAMPLE is charges to the analog source voltage for  $t_{ACQ}$ , by closing the TACQ switch for the acquisition time. In the conversion phase the TACQ is opened again and the voltage on CSAMPLE is converted to a digital value. Therefore

$FSAMPLE < 1 / (t_{ACQ} + t_{CONV})$  has to be maintained.

The time necessary to load CSAMPLE with sufficient preciseness to VSOURCE depends on the values of CSAMPLE, known 2,5pF typ., and the source resistance of VSOURCE, e.g. a potentiometer.

Therefore the max. allowed source resistance of VSOURCE depends on the programmed acquisition time.

TACQ / $\mu$ s	Max. resistance VSOURCE /k $\Omega$
3	10
5	40
10	100
15	200
20	400
40	800

Table 5:  $T_{ACQ}$  versus  $R(V_{SOURCE})$  max.

## 5. MODULE PINS

### 5.1. Pin Numbering

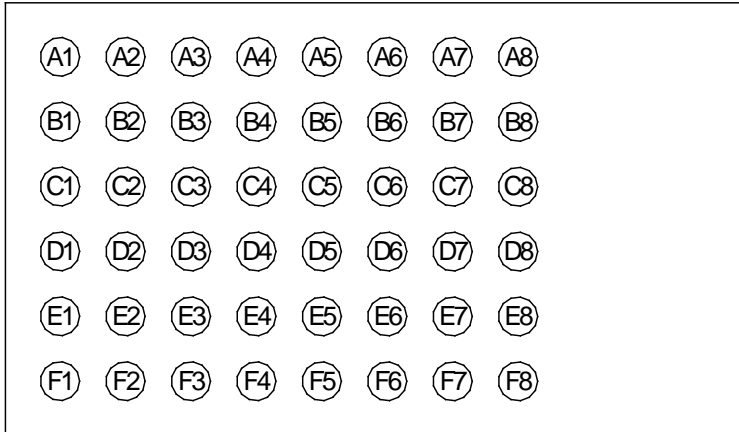

Figure 16: BlueMod+S50 Pin Numbering (Top View)



## 5.2. Pin Description

Pin Name	Signal	Alternate	Type <sup>(1)</sup>	Act	nRF52	Description
E6 F6	VSUP1		PWR		VDD	+3,0V nom.
A7 B[5-8] C[5-8] D8 E7 E8 F7 F8	GND		PWR		VSS	Ground All GND pins must be connected
A8	ANT PIN		RF		RF	AI: not connected AP: RF output (50Ω)
A3	NFCANT1		RF		P0.09	NFC-Antenna
A4	NFCANT2		RF		P0.10	NFC-Antenna
F1	TESTMODE#		I-PU <sup>(3)</sup>	L	P0.08	Enable Testmode
E1	BOOT0		I-PD <sup>(3)</sup>		P0.25	Startup with Bootloader
E3	SWDIO		I/O-PU		SWDIO	Serial Wire Debug (data)
D6	SWCLK		I-PD		SWCLK	Serial Wire Debug (clock)
B1	EXT-RES#		I-PU	L	P0.21	User Reset
A6	XL-IN		I/O		P0.00	XTAL 32,768kHz input
A5	XL-OUT		I/O		P0.01	XTAL 32,768kHz output
F4	UART-TXD		O-PP		P0.17	Serial Data OUT
D2	UART-RXD		I		P0.11 P0.13	Serial Data IN
D7	UART-RTS#		O-PU	L	P0.07	Flow Control/IUC (internally connected to a 470k pull up)
F3	UART-CTS#		I-PD <sup>(4)</sup>	L	P0.12	Flow Control/IUC
B4	IUR-OUT#		O-PP <sup>(4)</sup>	L	P0.04	UICP Control
D5	IUR-IN#		I-DIS <sup>(4)</sup>	L	P0.29	UICP Control
D3	GPIO[0]	I2C-SCL	I/O		P0.27	GPIO <sup>(2)</sup>
B2	GPIO[1]	AIN, I2C-SDA	I/O		P0.31	GPIO <sup>(2)</sup>
D1	GPIO[2]	SPI-MOSI	I/O		P0.14	GPIO <sup>(2)</sup>
E4	GPIO[3]	AIN	I/O		P0.02	GPIO <sup>(2)</sup>
D4	GPIO[4]	AIN	I/O		P0.30	GPIO <sup>(2)</sup>
F2	GPIO[5]	AIN, SPI-MISO	I/O		P0.05	GPIO <sup>(2)</sup>
C4	GPIO[6]	AIN	I/O		P0.03	GPIO <sup>(2)</sup>
C3	GPIO[7]	AIN	I/O		P0.28	GPIO <sup>(2)</sup>
E2	GPIO[8]	SPI-SCK	I/O		P0.06	GPIO <sup>(2)</sup>
A2	GPIO[9]		I/O		P0.18	GPIO <sup>(2)</sup>
A1	GPIO[10]		I/O		P0.22	GPIO <sup>(2)</sup>
B3	GPIO[11]		I/O		P0.20	GPIO <sup>(2)</sup>
E5	GPIO[12]		I/O		P0.16	GPIO <sup>(2)</sup>
C2	GPIO[13]		I/O		P0.15	GPIO <sup>(2)</sup>
F5	GPIO[14]		I/O		P0.26	GPIO <sup>(2)</sup>
C1	NC					not connected

<sup>(1)</sup> PWR: Power; I: Input; O: Output; I/O: bidir; PU: pull-up; PD: pull-down; DIS: disconnected; PP: push-pull; RF: RadioFreq

<sup>(2)</sup> Pin function depends used firmware, refer to 5.3

<sup>(3)</sup> signals sampled only at startup time, I-DIS otherwise

<sup>(4)</sup> Pin Type depends on UICP status. Refer to 4.3.4

**Table 6: Pin Assignments**

### 5.3. Firmware depend Functions

Signal	CEN	
	Type <sup>(1)</sup>	Function
GPIO[0]	DIS	none
GPIO[1]	DIS	none
GPIO[2]	DIS	none
GPIO[3]	O	IOB
GPIO[4]	I-PU	HANGUP
GPIO[5]	DIS	none
GPIO[6]	DIS	none
GPIO[7]	DIS	none
GPIO[8]	O	IOA
GPIO[9]	DIS	none
GPIO[10]	DIS	none
GPIO[11]	DIS	none
GPIO[12]	DIS	none
GPIO[13]	DIS	none
GPIO[14]	DIS	none

<sup>(1)</sup> I: Input; O: Output; I/O: bidir; PU: pull-up; PD: pull-down; DIS: disconnected; PP: push-pull;

*Table 7: Firmware depend GPIO function*

### 5.4. Handling of Unused Signals

Depending on the application, not all signals of BlueMod+S50 may be needed. The following list gives some hints how to handle unused signals.

Signal	Handling
EXT-RES#	If no external Reset is needed: Leave open
UART-RXD	add a pullup (e.g.100kΩ) to VSUP <sup>(1)</sup>
UART-TXD	leave UART-TXD open <sup>(1)</sup>
UART-RTS#, UART-CTS#	If neither flow control nor UICP is used: Leave open <sup>(1)(2)</sup>
IUR-OUT#, IUR-IN#	If UICP is not used: leave open
TESTMODE#	Leave open <sup>(1)</sup>
unused GPIOs	Leave open
SWDIO, SWCLK	Leave open. Only needed for debug purposes

<sup>(1)</sup> Signals must be accessible for regulatory approving

<sup>(2)</sup> It is strongly recommended to use hardware flow control in both directions. Not using flow control can cause loss of data.

*Table 8: Handling of Unused Signals*

## 6. ELECTRICAL CHARACTERISTICS

### 6.1. Absolute Maximum Ratings

Stresses beyond those listed under “Absolute Maximum Ratings” may cause permanent damage to the device. These are stress ratings only and functional operation of the device at these or any other conditions beyond those indicated under “Electrical Requirements” is not implied. Exposure to absolute-maximum-rated conditions for extended periods may affect device reliability.

Symbol	Item	Condition	Limit			Unit
			Min	Typ	Max	
VSUP	Supply voltage		-0,3		3,6	V
V <sub>Pin</sub>	Voltage on any pin		-0,3		VSUP+0,3 ≤ 3,6	V
P <sub>RFIn</sub>	RF input level				10	dBm
I <sub>NFC1/2</sub>	NFC antenna pin current				80	mA
T <sub>stg</sub>	Storage temperature range		-40		+125	°C

Table 9: Absolute Maximum Ratings

### 6.2. Operating Conditions

Symbol	Item	Condition	Limit			Unit
			Min	Typ	Max	
VSUP	Supply voltage	DC/DC not enabled	1,7	3,0	3,6	V <sub>DC</sub>
		DC/DC enabled	1,7	3,0	3,6	V <sub>DC</sub>
t <sub>rise</sub>	Supply rise time	0V to 1,7V			60	ms
T <sub>op</sub>	Operating temperature range		-40		+85	°C

Table 10: Operating Conditions

### 6.3. DC Parameter

All Module I/O pins are connected directly to the Nordic nRF52832 chip without signal conditioning except for some pull-up/pull-down resistors (as indicated). Therefore, the electrical characteristics are as documented in the Nordic nRF52832 data sheet [8].

#### 6.3.1. General Purpose I/O (GPIO)

$T_{amb} = 25^{\circ}\text{C}$   $VSUP = 1,7$  to  $3,6\text{V}$

Symbol	Item	Condition	Limit			Unit
			Min	Typ	Max	
$V_{IL}$	Input Low Voltage				$0,3 \cdot VSUP$	V
$V_{IH}$	Input High Voltage		$0,7 \cdot VSUP$			V
$V_{OL}$	Output Low Voltage				$VSS + 0,4$	V
$V_{OH}$	High-Level Output Voltage		$VSUP - 0,4$			V
$I_{OL}/I_{OH}$	Low and High Level Output Current	drive = std			0,5	mA
		drive = hi <sup>(1)</sup>			5	mA
$R_{PU}/R_{PD}$	pull-up/down resistor		11	13	16	k $\Omega$
$C_i$	Pad Capacitance			3,0		pF

<sup>(1)</sup> maximal number of pins (per package) with high drive is 3

*Table 11: DC Characteristics, Digital IO*

#### 6.3.2. Reset

Input EXT-RES# has a Schmitt-Trigger characteristic and an internal pull-up resistor.

$T_{amb} = 25^{\circ}\text{C}$   $VSUP = 1,7$  to  $3,6\text{V}$

Symbol	Item	Condition	Limit			Unit
			Min	Typ	Max	
$V_{IL}$	Low-Level Threshold			$0,25 \cdot VSUP$		V
$V_{IH}$	High-Level Threshold			$0,75 \cdot VSUP$		V
$R_{PU}$	pull-up resistor		11	13	16	k $\Omega$
$C_i$	Input Capacitance			3		pF

*Table 12: Reset Characteristics*

## 6.4. Power Consumption and Power-Down Modes

### 6.4.1. BlueMod+S50/AI CEN FW

The following values are typical power consumption values in different states of operation. BlueMod+S50 configured as a peripheral device.

VSUP = 3,0V, T<sub>amb</sub> = 25°C, all GPIO lines left open

Mode	Condition	Note	Current Consumption (I <sub>Avg</sub> )	Unit
			Tx power: +4dBm (max)	
AI				
System off	CPU off, Radio inactive, 32k clock off, SRAM Retention off, wakeup by RESET		0,3	μA
Reset	Device hold in Reset		0,4	mA
UICP active and serial interface down	Standby, Advertising Off (Radio inactive)		9,1	μA
	Standby, Advertising, 3 channels advertising interval: 1.28s		17,6	μA
	Connected, connection interval: 1.28s	(1)	10,4	μA
UICP not active or serial interface up	Idle, Advertising Off (Radio inactive)		1,2	mA
	Advertising, 3 channels advertising interval: 1.28s		1,2	mA
	Connected, connection interval: 1.28s	(1)	1,2	mA
	Connected, connection interval: 40ms	(1,2)	1,3	mA
	Connected, connection interval: 7,5ms	(1)	1,6	mA
	Connected, connection interval: 7,5ms, data traffic 115 kbit/s at the serial port	(1)	2,5	mA

<sup>(1)</sup> connection parameters are setup by the central device when connection is established

<sup>(2)</sup> these are a typical connection parameters used by an iPhone, iPad or iPad mini device in the central device role

Table 13: Supply Current BLE Terminal I/O Profile, Peripheral Device Role

## 6.5. RF Performance

### 6.5.1. BLE Receiver

VSUP = 3,0V, T<sub>amb</sub> = +25°C, PHY type: LE 1Msps

Receiver	Conditions	Min	Typ	Max	BT Spec	Unit
Sensitivity	PER ≤ 30,8%	-93,0			≤ -70	dBm
max received input level	PER ≤ 30,8%		0		≥ -10	dBm
max PER report integrity Wanted signal level -30dBm	2,426 Ghz		50		50 < PER < 65,4	%
Blocker Power Wanted signal level -67dBm	0,030 – 2,000	-30			-30	dBm
	2,000 – 2,400	-35			-35	
	2,500 – 3,000	-35			-35	
	3,000 – 12,75	-30			-30	
Adjacent channel Selectivity C/I	co-channel		10		≤21	dB
	F = F0 + 1 MHz		1		≤15	dB
	F = F0 - 1 MHz		1		≤15	dB
	F = F0 + 2 MHz		-25		≤-17	dB
	F = F0 - 2 MHz		-25		≤-15	dB
	F = F0 + 3 MHz		-51		≤-27	dB
	F = Fimage		-30		≤-9	dB
max intermodulation level			-36		≥-50	dBm

Table 14: RF Performance BLE Receiver @1Msps

### 6.5.2. BLE Transmitter

VSUP = 1,7V to 3,6V, T<sub>amb</sub> = +25°C, PHY type: LE 1Msps

Transmitter	Conditions	Min	Typ	Max	BT Spec	Unit
RF Transmit Power	-		4		-20 to +10	dBm
Programmable RF Transmit Power Range	-	-20		+4		dBm
RF Transmit Power "Whisper Mode"	-		-40		N/A	dBm
Adjacent Channel Power ACP	F = F0 ± 2MHz		-48		≤ -20	dBm
	F = F0 ± 3MHz		-55		≤ -30	
	F = F0 ± > 3MHz		<-60		≤ -30	
Modulation Characteristics	Δf1avg		255		225 ... 275	kHz
	Δf2max Thrsh. 185kHz		100		≥ 99,9	%
	Δf2avg / Δf1avg		1,0		≥ 0,8	
Carrier Frequency Offset and drift	Avg Fn		±20		± 150	kHz
	avg drift		5		≤ 50	kHz
	max drift rate		5		≤ 20	kHz/50μs

Table 15: RF Performance BLE Transmitter @1Msps

## 6.6. Antenna-Gain and Radiation Pattern for BlueMod+S50/AI

If BlueMod+S50/AI is integrated into an end product while the recommendations depicted in chapter 7.4 are maintained, the following typical antenna radiation patterns can be expected.

Radiation Pattern will depend on the end products PCB size, masses in the antenna environment, housing material and geometrics.

Typical antenna gain is about 2 dBi.

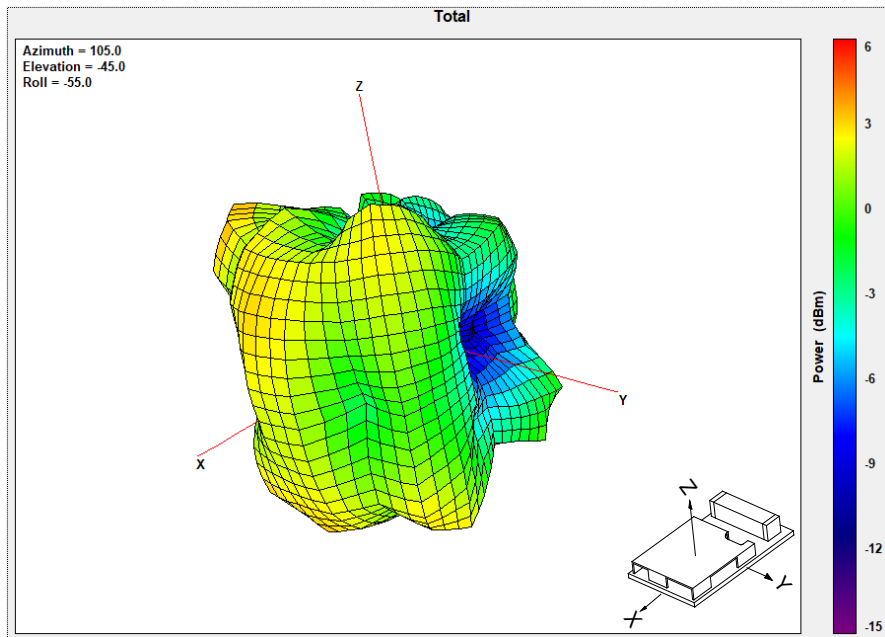

Figure 17: Typical Antenna Radiation Pattern at 2402MHz

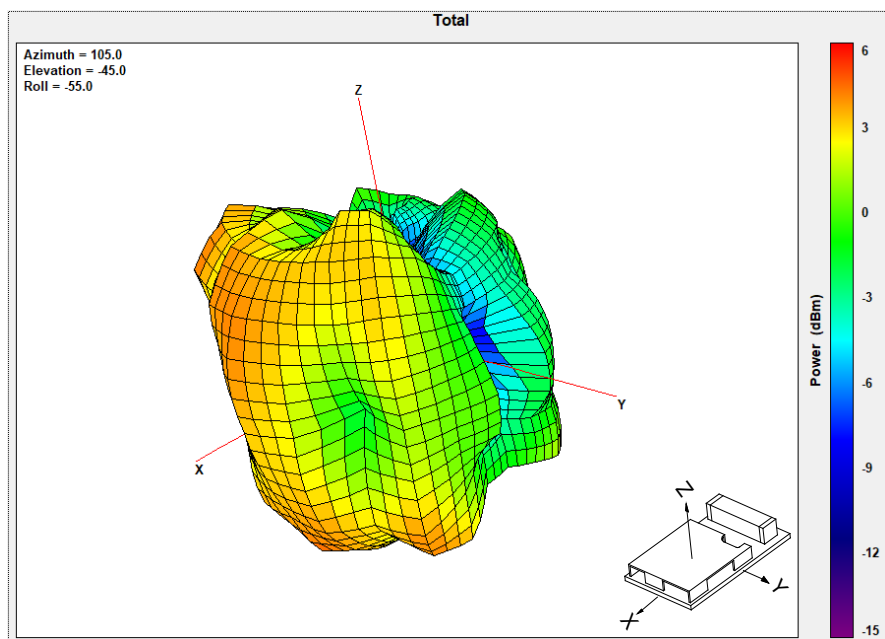

Figure 18: Typical Antenna Radiation Pattern at 2440MHz

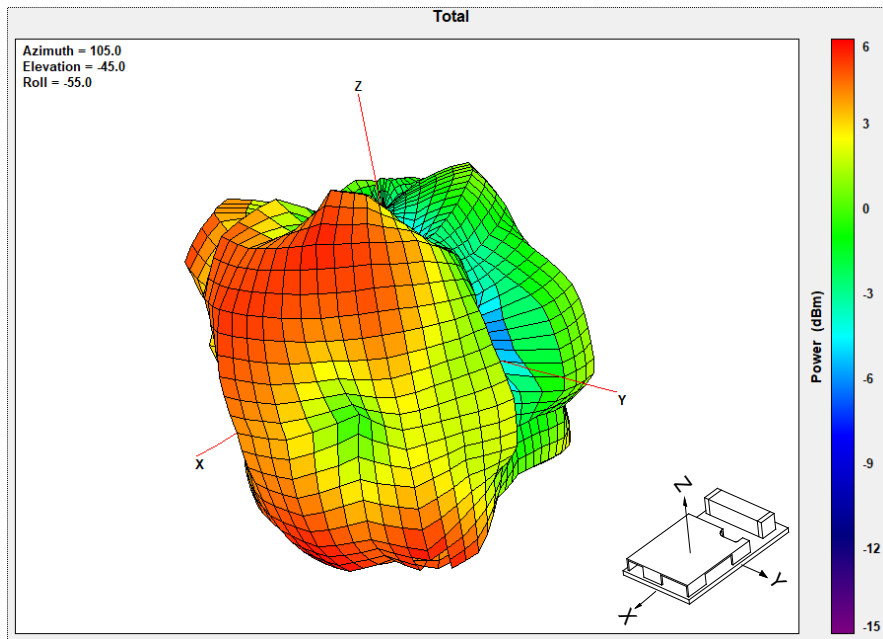

Figure 19: Typical Antenna Radiation Pattern at 2480MHz



## 7. MECHANICAL CHARACTERISTICS



All dimensions are in millimeters.

### 7.1. Dimensions

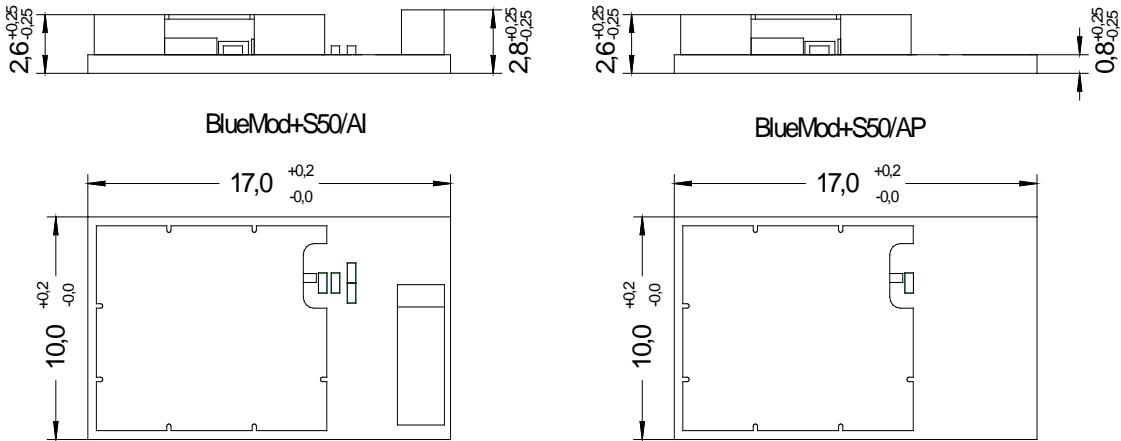

Figure 20: BlueMod+S50/AI an /AP Dimensions

### 7.2. Recommended Land Pattern

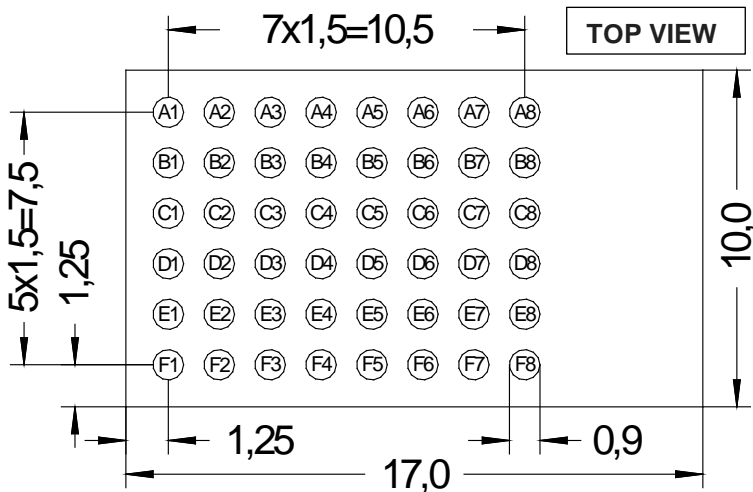

Figure 21: BlueMod+S50 Land Pattern



### 7.4. AI Layout and Placement Recommendation

BlueMod+S50/AI comprises a ceramic antenna, which as a component is soldered to the circuit board. The performance of the antenna has to be checked within the final integration environment. Adjacent PCBs, components, cables, housings etc. could otherwise influence the radiation pattern or be influenced by the radio wave energy.

To achieve best radio performance for BlueMod+S50/AI, it is recommended to use the placement and layout shown in Figure 23 and Figure 24. This is a “corner placement” meaning the module is placed such that the antenna comes close to the corner of the application PCB (red area). So, the yellow area is outside the PCB and regards to the housing, too (refer to 7.6).

Please note that for best possible performance the antenna should be directed away from the application PCB as shown in Figure 23.

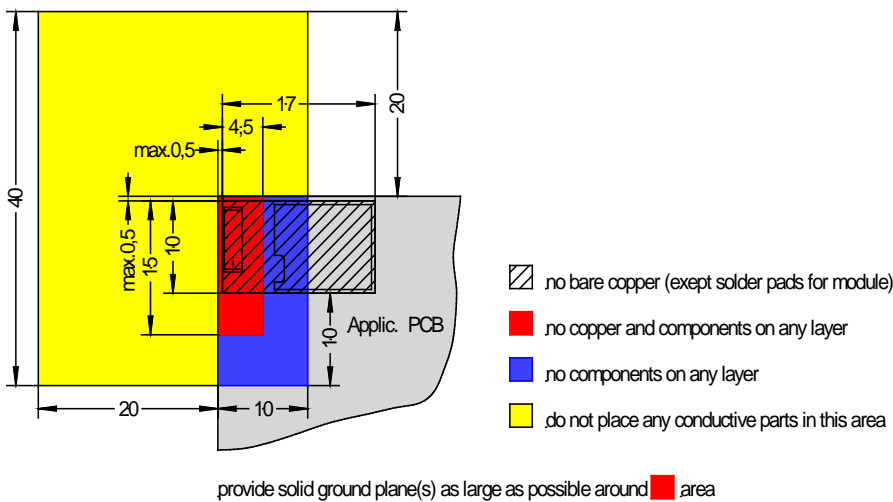

Figure 23: AI placement recommendation

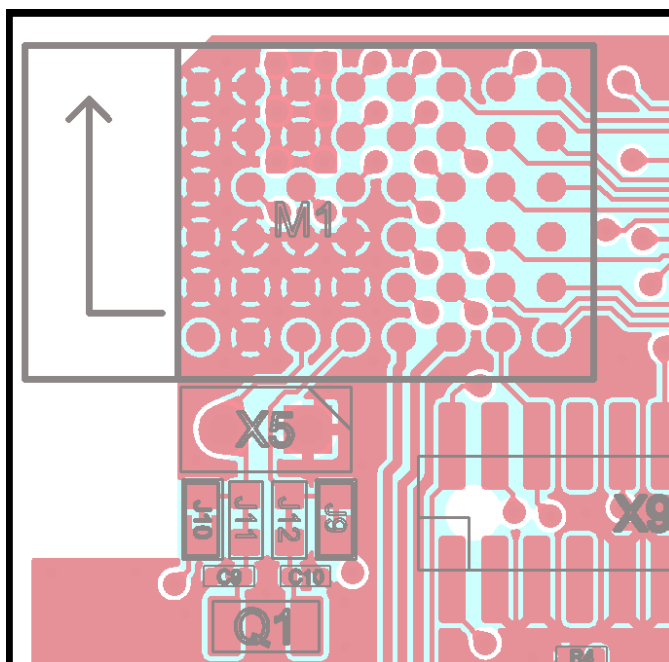

Figure 24: AI layout recommendation

## 7.5. OEM Layout and Antenna Selection in Respect to RED/FCC/IC Certification

Placement for BlueMod+S50/AP, is not restricted. For antenna port connection it is recommended to use a layout like shown in Figure 26.

To keep specified radio power values the impedance of the RF trace connected to the antenna port shall be 50 Ohms. Impedance of the RF trace depends on customer pcb. Use a calculator for coplanar waveguides e.g. "TXline" to determine track width and gap between ground and RF track.

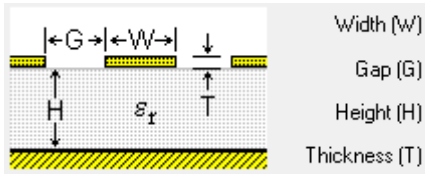

Figure 25: coplanar waveguide sample



Figure 26: AP antenna port layout recommendation

OEM integrators are free with choosing a trace design suitable for their end product and selecting an antenna according to their needs. Only if it is desired to re-use the RED/FCC and IC certification of the BlueMod+S50/AP the following restrictions apply.

- 1) Use External Antenna: antenova part no B4844-R

Please note that for FCC Certification it is mandatory to use a reverse SMA connector instead of using a standard SMA male connector on the antenna side.

- 2) Exactly follow the Trace Design with below given parameters

The RF trace on the Telit standalone testboard used for homologation lab testing is placed on the top side of a standard FR4 4 layer PCB with  $\epsilon_r \approx 4,7$  and designed as microstrip transmission line with the below given parameters.

In many cases the antenna is required to be mounted in another position on the end product. This could be achieved by using SMA/SMA coax cables.

a. Trace Design Impedance 50R Calculation

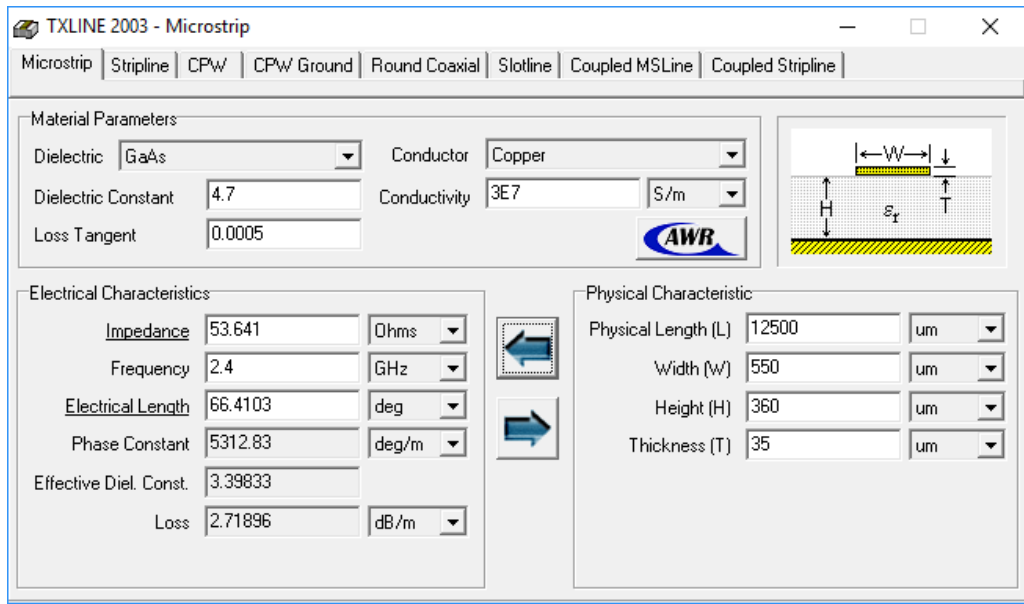

Figure 27: RF Trace Impedance Calculation Parameters

b. Trace Design Geometry

It is important to avoid coupling of noise from digital lines to the RF trace and also to avoid RF signal coupling into power supply or analogue lines. Therefore, the following RF trace design geometry has been successfully used on the Telit standalone testboard and should be followed by OEM's re-using BlueMod+S50/AP RED/FCC or IC Certifications.

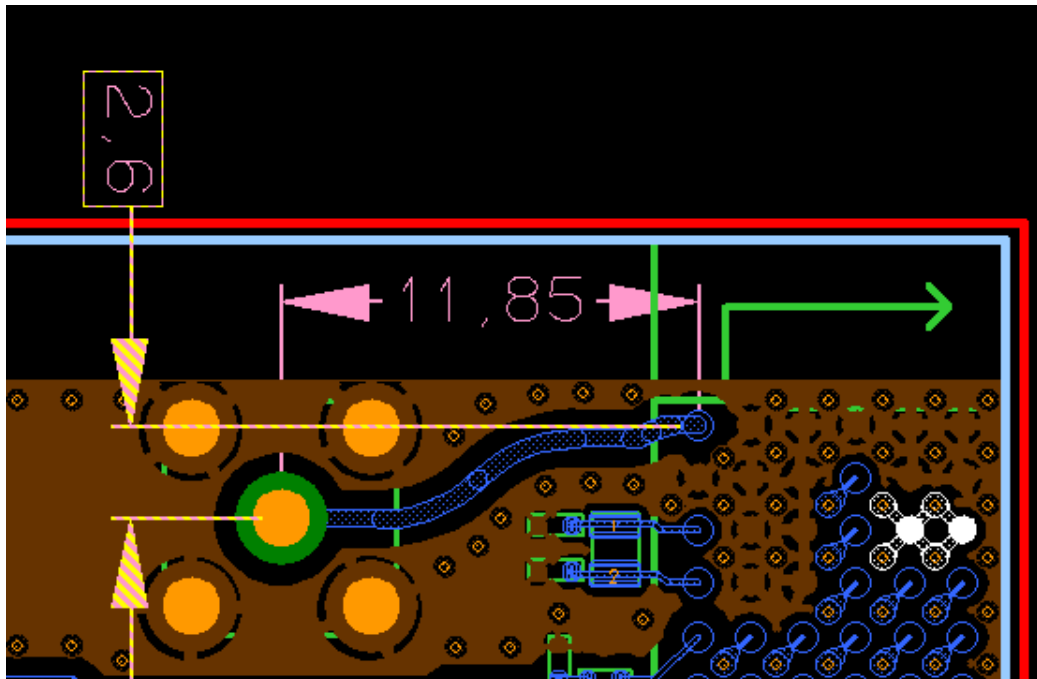

Figure 28: RF Trace Design Geometry

## 7.6. Housing Guidelines

The individual case must be checked to decide whether a specific housing is suitable for the use of the internal antenna. A plastic housing must at least fulfill the following requirements:

- Non-conductive material, non-RF-blocking plastics
- No metallic coating
- ABS is suggested

## 7.7. Safety Guidelines

According to SAR regulation EN 62479:2010 the BlueMod+S50/AI is not intended to be used in close proximity to the human body. Please refer to above-mentioned regulation for more specific information.

In respect to the safety regulation EN 62368-1:2014 + AC:2015 all conductive parts of the BlueMod+S50 are to be classified as SELV circuitry. OEM's implementing the BlueMod+S50 in their products should follow the isolation rules given in regulation EN 62368-1:2014.

The PCB material of the BlueMod+S50 is classified UL-94V0.

## 7.8. Cleaning

In general, cleaning the modules mounted on the host board is strongly discouraged. Residues between module and host board cannot be easily removed with any cleaning method.

- Cleaning with water or any organic solvent can lead to capillary effects where the cleaning solvent is absorbed into the gap between the module and the host board. The combination of soldering flux residues and encapsulated solvent could lead to short circuits between conductive parts. The solvent could also damage any labels.
- Ultrasonic cleaning could damage the module permanently. Especially for crystal oscillators the risk of damaging is very high.

## 8. APPLICATION DIAGRAM

Figure 29 shows a typical application of BlueMod+S50. The module is connected to some MCU running the application layer. MCU and BlueMod+S50 use the same 3,3V power supply. The serial interface has RTS/CTS flow control and UICP support in this example. The optional hangup feature to close down the link is provided.

All other module pins may be left unconnected.

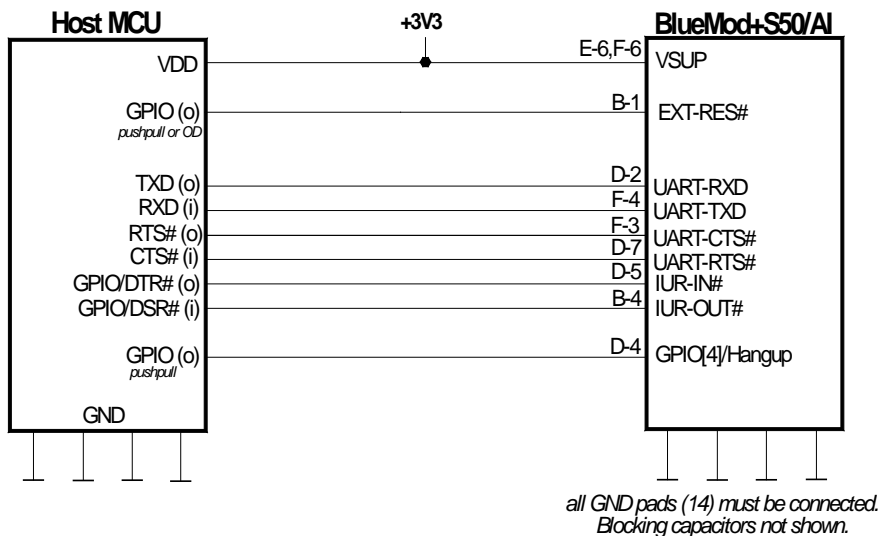

In this example BlueMod+S50/AI is connected to an MCU supporting UICP, RTS/CTS flow control and Hangup.

Figure 29: Typical Application Schematics

## 9. COMPLIANCES

The BlueMod+S50/AI and BlueMod+S50/AP have been tested to fully comply with the appropriate EU, FCC and IC directives.

CE testing is intended for end products only. Therefore, CE testing is not mandatory for a Bluetooth module sold to an OEM end product. However, Telit provides CE tested modules for customers in order to ease CE compliance assessment of end products and to minimize test effort.

OEM end product compliance assessment has to be done for every end product by the OEM's certification manager. It should be noted that compliance assessment doesn't necessarily mean re-testing in the test lab. Telit test reports are available on request and can be used to drastically reduce the test plan and compliance testing costs.



All certifications and declarations, except RoHS and Reach, are only valid for the BlueMod+S50 running with Telit FW. If the FLASH is erased and a customer specific FW is loaded all certifications have to be re-evaluated or renewed.



All measurements and certifications have been done for the BlueMod+S50/AI with internal ceramic antenna and with a specific external antenna for the BlueMod+S50/AP, which offers the RF signal on a module pin. For the BlueMod+S50/AP the RED; FCC and IC certifications stay valid if the OEM design follows exactly the standalone test board trace design and uses exactly the same antenna given in chapter 7.5 OEM Layout and Antenna Selection in Respect to RED/FCC/IC Certification.

If this trace design is not the same or the this specific antenna is not used the following actions should be done.

- RED Re-assess RED compliance
- FCC Class II Permissive Change
- IC Class II Permissive Change

---

### 9.1. Declaration of Conformity CE

The BlueMod+S50/AI and the BlueMod+S50/AP do fully comply with the essential requirements of the following EU directives:

- RED 2014/53/EU
- RoHS 2011/65/EC

The actual version of EU Declaration of Conformity (EU DoC) can be downloaded from <https://www.telit.com/RED>



## 9.2. FCC Compliance

The BlueMod+S50/AI and the BlueMod+S50/AP have been tested to fulfill the FCC requirements. Test reports are available on request.

### 9.2.1. FCC Grant

The actual version of the FCC Grant can be downloaded from the Telit Download Zone:

<https://www.telit.com/support-training/download-zone/>

Take note that you have to register to get access to the Download Zone.

### 9.2.2. FCC Statement

This device complies with 47 CFR Part 2 and Part 15 of the FCC Rules.

Operation is subject to the following two conditions:

- (1) this device may not cause harmful interference, and
- (2) this device must accept any interference received, including interference that may cause undesired operation.

### 9.2.3. FCC Caution



**WARNING:**

Changes or modifications made to this equipment not expressly approved by Telit may void the FCC authorization to operate this equipment

---

### 9.2.4. FCC Warning

This equipment has been tested and found to comply with the limits for a Class B digital device, pursuant to Part 15 of the FCC Rules. These limits are designed to provide reasonable protection against harmful interference in a residential installation. This equipment generates, uses and can radiate radio frequency energy and, if not installed and used in accordance with the instructions, may cause harmful interference to radio communications. However, there is no guarantee that interference will not occur in a particular installation. If this equipment does cause harmful interference to radio or television reception, which can be determined by turning the equipment off and on, the user is encouraged to try to correct the interference by one or more of the following measures:

- Reorient or relocate the receiving antenna.
- Increase the separation between the equipment and receiver.
- Connect the equipment into an outlet on a circuit different from that to which the receiver is connected.

Consult the dealer or an experienced radio/TV technician for help.

#### 9.2.5. FCC RF-exposure Statement

The BlueMod+S50/AI and BlueMod+S50/AP, if used with the antenna described in chapter 7.5 OEM Layout and Antenna Selection in Respect to RED/FCC/IC Certification, do comply with the FCC/IC RF radiation exposure limits set forth for an uncontrolled environment.

According to table 1B of 47 CFR 1.11310 "Limits for Maximum Permissible Exposure (MPE), Limits for General Population / Uncontrolled Exposure" the power density at 20 cm distance to the human body is well below the limit of 1mW/cm<sup>2</sup>.



For the BlueMod+S50/AI the distance to the human body may be 0cm. The same applies for the BlueMod+S50/AP if the specific antenna stated in 7.5 OEM Layout and Antenna Selection in Respect to RED/FCC/IC Certification is used. But if a different antenna is used, MPE has to be re-evaluated.

---

#### 9.2.6. FCC Labeling Requirements for the End Product

Any End Product integrating the BlueMod+S50/AI or BlueMod+S50/AP must be labeled with at least the following information:

This device contains transmitter with

FCC ID: RFR-S50

IC: 4957A-S50

### 9.3. IC Compliance

The BlueMod+S50/AI and BlueMod+S50/AP have been tested to fulfill the IC requirements. Test reports RSS-210 of Industry Canada are available on request.

#### 9.3.1. IC Grant

The actual version of the IC Grants can be downloaded from the Telit Download Zone:

<https://www.telit.com/support-training/download-zone/>

Take note that you have to register to get access to the Download Zone.

#### 9.3.2. IC Statement

(i) Ce dispositif doit être installé et exploité dans une enceinte entièrement fermée afin de prévenir les rayonnements RF qui pourraient autrement perturber la navigation aéronautique. L'installation doit être effectuée par des installateurs qualifiés, en pleine conformité avec les instructions du fabricant.

(ii) Ce dispositif ne peut être exploité qu'en régime de non-brouillage et de non-protection, c'est-à-dire que l'utilisateur doit accepter que des radars de haute puissance de la même bande de fréquences puissent brouiller ce dispositif ou même l'endommager. D'autre part, les capteurs de niveau à propos desquels il est démontré qu'ils perturbent une exploitation autorisée par licence de fonctionnement principal doivent être enlevés aux frais de leur utilisateur.

This device complies with Industry Canada license-exempt RSS standard(s). Operation is subject to the following two conditions:

- (1) this device may not cause interference, and
- (2) this device must accept any interference, including interference that may cause undesired operation of the device.

Cet appareil est conforme aux normes RSS exemptes de licence d'Industrie Canada. L'utilisation est soumise aux deux conditions suivantes:

- (1) cet appareil ne doit pas causer d'interférences, et
- (2) cet appareil doit accepter toute interférence, y compris les interférences susceptibles de provoquer un fonctionnement indésirable de l'appareil.

#### **NOTICE:**

This Class B digital apparatus complies with Canadian ICES-003.

Cet appareil numérique de la classe B est conforme à la norme NMB-003 du Canada.

### 9.3.3. IC Caution

**WARNING:**

Changes or modifications made to this equipment not expressly approved by Telit may void the IC authorization to operate this equipment.

---

### 9.3.4. IC RF-exposure Statement

This equipment is portable device. According to RSS-102 Issue 5 §2.5.1 Exemption Limits for Routine Evaluation – SAR Evaluation Table 1, the allowed distances to the human body for products implementing the BlueMod+S50/AI or BlueMod+S50/AP can be calculated as follows. If the intended use of the end product asks for smaller distances a SAR evaluation has to be repeated with the end product.

- Max. RF output power is +3.5dBm
- Antenna peak Gain is +3dBi
- Resulting max. RF output power is +6.5dBm = 4.5mW < 7mW
- Table 1 of RSS-102 Issue 5 §2.5.1 shows that for 2450MHz the distance at 7mW should be  $\geq 1\text{cm}$

If the BlueMod+S50/AP is used with a different antenna as stated in 7.5OEM Layout and Antenna Selection in Respect to RED/FCC/IC Certification, SAR evaluation has to be re-newed.

### 9.3.5. IC Labeling Requirements for the End Product

Any end product integrating the BlueMod+S50/AI or BlueMod+S50/AP must be labeled with at least the following information:

This device contains transmitter with

FCC ID: RFR-S50

IC-ID: 4957A-S50

### 9.3.6. IC Label Information BlueMod+S50

The BlueMod+S50/AI and the BlueMod+S50/AP show the IC-ID on the product label.

Model: BlueMod+S50

**The IC-ID is: 4957A-S50**

#### 9.4. Bluetooth Qualification

Bluetooth qualification is in progress.

#### 9.5. RoHS Declaration

RoHS evaluation is in progress.

## 10. PACKING

The BlueMod+S50 modules are packed either as Tape&Reel or as tray packing.

### 10.1. Tape&Reel Packing

The BlueMod+S50 modules are packed using carrier tape in this orientation.

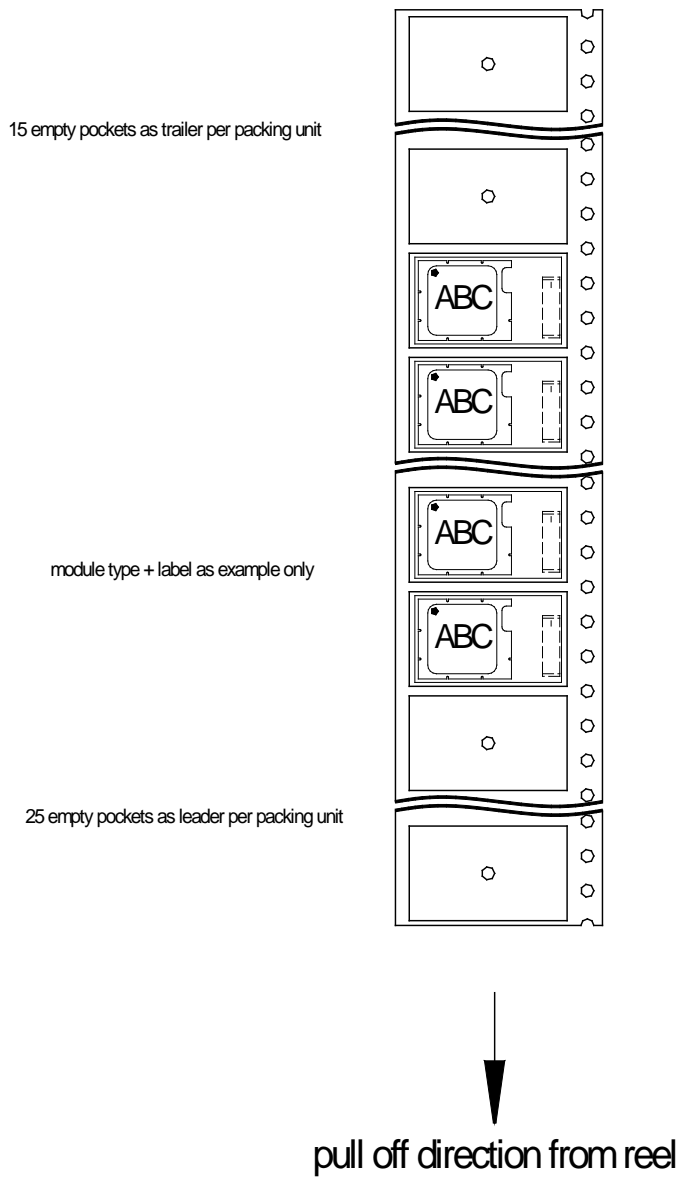

Figure 30: Module Orientation in Carrier Tape

### 10.1.1. Tape

The dimensions of the tape are shown in Figure 31 (values in mm):

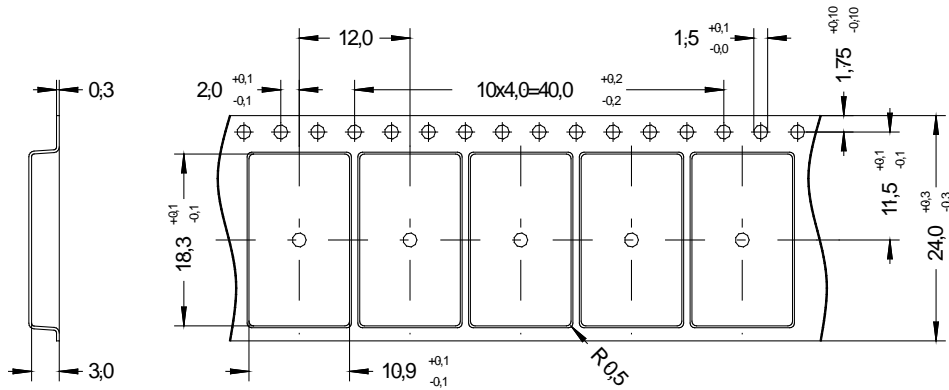

Figure 31: Carrier Tape Dimensions

### 10.1.2. Reel

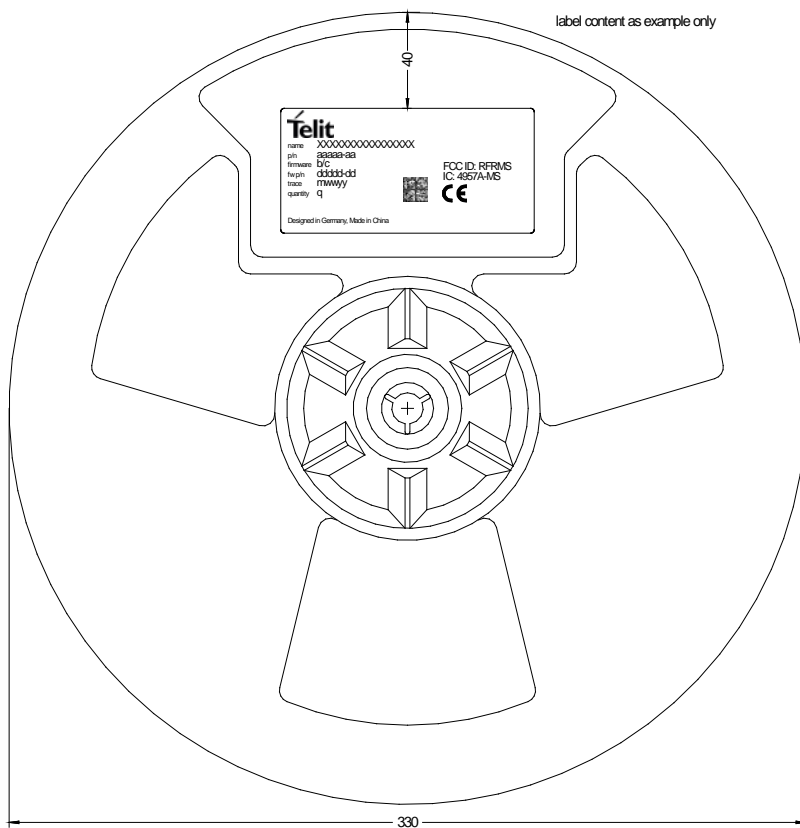

Figure 32: Reel Dimensions

## 10.2. Tray Packing

### 10.2.1. Module Orientation

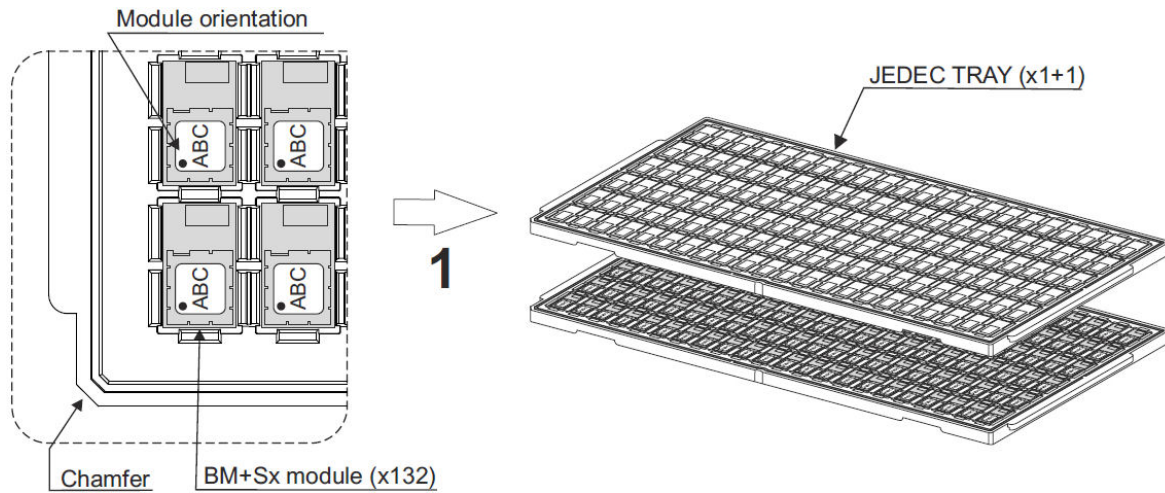

Figure 33: Module Orientation on Tray

### 10.2.2. Tray Dimensions

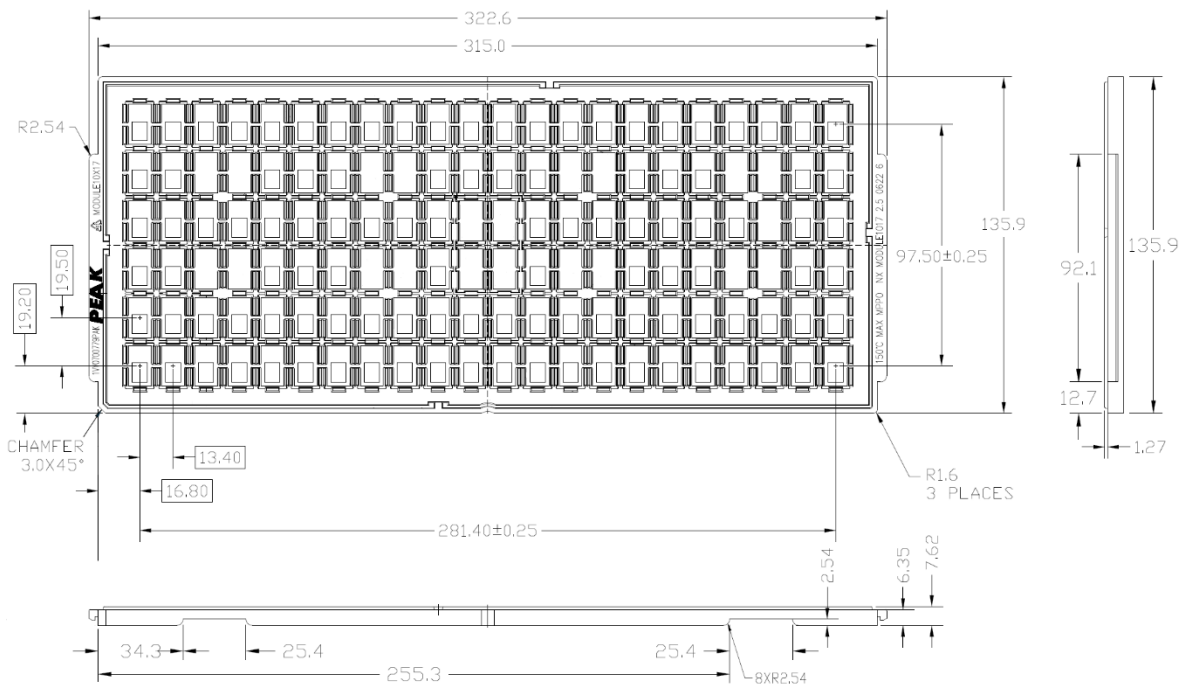

Figure 34: Tray Dimensions

## 10.3. Moisture Sensitivity Level

Moisture Sensitivity Level (MSL) for BlueMod+S50 is 3.



## 11. EVALUATION KIT

Following evaluation kits are available:

- BLUEEVA+S50/AI

Please refer to [5] for additional informations.

## 12. SAFETY RECOMMENDATIONS

---



Read carefully

---

Be sure the use of this product is allowed in the country and in the environment required. The use of this product may be dangerous and has to be avoided in the following areas:

- Where it can interfere with other electronic devices in environments such as hospitals, airports, aircrafts, etc.
- Where there is risk of explosion such as gasoline stations, oil refineries, etc. It is the responsibility of the user to enforce the country regulation and the specific environment regulation.

Do not disassemble the product; any mark of tampering will compromise the warranty validity. We recommend following the instructions of the hardware user guides for correct wiring of the product. The product has to be supplied with a stabilized voltage source and the wiring has to be conformed to the security and fire prevention regulations. The product has to be handled with care, avoiding any contact with the pins because electrostatic discharges may damage the product itself. Same cautions have to be taken for the SIM, checking carefully the instruction for its use. Do not insert or remove the SIM when the product is in power saving mode.

The system integrator is responsible for the functioning of the final product; therefore, care has to be taken to the external components of the module, as well as any project or installation issue, because the risk of disturbing the GSM network or external devices or having impact on the security. Should there be any doubt, please refer to the technical documentation and the regulations in force. Every module has to be equipped with a proper antenna with specific characteristics. The antenna has to be installed with care in order to avoid any interference with other electronic devices and has to guarantee a minimum distance from the body (20 cm). In case this requirement cannot be satisfied, the system integrator has to assess the final product against the SAR regulation.

The European Community provides some Directives for the electronic equipment introduced on the market. All of the relevant information is available on the European Community website:

<http://ec.europa.eu/enterprise/sectors/rtte/documents/>

The text of the Directive 99/05 regarding telecommunication equipment is available, while the applicable Directives (Low Voltage and EMC) are available at:

<http://ec.europa.eu/enterprise/sectors/electrical/>

## 13. ACRONYMS

TTSC	Telit Technical Support Centre
USB	Universal Serial Bus
DTE	Data Terminal Equipment
UART	Universal Asynchronous Receiver Transmitter
SPI	Serial Peripheral Interface
I/O	Input Output
GPIO	General Purpose Input Output
CMOS	Complementary Metal – Oxide Semiconductor
MOSI	Master Output – Slave Input
MISO	Master Input – Slave Output
CLK	Clock
CS	Chip Select
PCB	Printed Circuit Board
ESR	Equivalent Series Resistance
VSWR	Voltage Standing Wave Ratio
VNA	Vector Network Analyzer

## 14. DOCUMENT HISTORY

Revision	Date	Changes
0	2018-03-02	Initial release
1	2018-03-22	FCC and IC compliance updated



# SUPPORT INQUIRIES

Link to [www.telit.com](http://www.telit.com) and contact our technical support team for any questions related to technical issues.

[www.telit.com](http://www.telit.com)



---

Telit Communications S.p.A.  
Via Stazione di Prosecco, 5/B  
I-34010 Sgonico (Trieste), Italy

Telit Wireless Solutions Inc.  
3131 RDU Center Drive, Suite 135  
Morrisville, NC 27560, USA

Telit Wireless Solutions Ltd.  
10 Habarzel St.  
Tel Aviv 69710, Israel

Telit IoT Platforms LLC  
5300 Broken Sound Blvd, Suite 150  
Boca Raton, FL 33487, USA

Telit Wireless Solutions Co., Ltd.  
8th Fl., Shinyoung Securities Bld.  
6, Gukjegeumyung-ro8-gil, Yeongdeungpo-gu  
Seoul, 150-884, Korea

Telit Wireless Solutions  
Tecnologia e Servicos Ltda  
Avenida Paulista, 1776, Room 10.C  
01310-921 São Paulo, Brazil

---

Telit reserves all rights to this document and the information contained herein. Products, names, logos and designs described herein may in whole or in part be subject to intellectual property rights. The information contained herein is provided "as is". No warranty of any kind, either express or implied, is made in relation to the accuracy, reliability, fitness for a particular purpose or content of this document. This document may be revised by Telit at any time. For most recent documents, please visit [www.telit.com](http://www.telit.com)

Copyright © 2016, Telit