

BreezeCOMPACT

System Manual

Release Version:4.1
March 2013
P/N 516043





Legal Rights

© Copyright 2014 Telrad Networks Ltd. All rights reserved.

The material contained herein is proprietary, privileged, and confidential and owned by Telrad Networks or its third party licensors. No disclosure thereof shall be made to third parties without the express written permission of Telrad Networks Ltd.

Telrad Networks Ltd. reserves the right to alter the equipment specifications and descriptions in this publication without prior notice. No part of this publication shall be deemed to be part of any contract or warranty unless specifically incorporated by reference into such contract or warranty.

Trade Names

BreezeCOM[®], WALKair[®], WALKnet[®], BreezeMAX[®], BreezeLITE[®], BreezePHONE[®], 4Motion[®], and/or other products and Telrad Networks/or services referenced here in are either registered trademarks, trademarks or service marks of Telrad Networks Ltd.

All other names are or may be the trademarks of their respective owners.

“WiMAX Forum” is a registered trademark of the WiMAX Forum. “WiMAX,” the WiMAX Forum logo, “WiMAX Forum Certified”, and the WiMAX Forum Certified logo are trademarks of the WiMAX Forum.

Statement of Conditions

The information contained in this manual is subject to change without notice. Telrad Networks Ltd. shall not be liable for errors contained herein or for incidental or consequential damages in connection with the furnishing, performance, or use of this manual or equipment supplied with it.

Warranties and Disclaimers

All Telrad Networks Ltd. (“Telrad Networks”) products purchased from Telrad Networks or through any of Telrad Networks's authorized resellers are subject to the following warranty and product liability terms and conditions.

Exclusive Warranty

(a) Telrad Networks warrants that the Product hardware it supplies and the tangible media on which any software is installed, under normal use and conditions, will be free from significant defects in materials and workmanship for a period of fourteen (14) months from the date of shipment of a given Product to Purchaser (the "Warranty Period"). Telrad Networks will, at its sole option and as Purchaser's sole remedy, repair or replace any defective Product in accordance with Telrad Networks' standard R&R procedure.

(b) With respect to the Firmware, Telrad Networks warrants the correct functionality according to the attached documentation, for a period of fourteen (14) month from invoice date (the "Warranty Period)". During the Warranty Period, Telrad Networks may release to its Customers firmware updates, which include additional performance improvements and/or bug fixes, upon availability (the "Warranty"). Bug fixes, temporary patches and/or workarounds may be supplied as Firmware updates.

Additional hardware, if required, to install or use Firmware updates must be purchased by the Customer. Telrad will be obligated to support solely the two (2) most recent Software major releases.

TELRAD NETWORKS SHALL NOT BE LIABLE UNDER THIS WARRANTY IF ITS TESTING AND EXAMINATION DISCLOSE THAT THE ALLEGED DEFECT IN THE PRODUCT DOES NOT EXIST OR WAS CAUSED BY PURCHASER'S OR ANY THIRD PERSON'S MISUSE, NEGLIGENCE, IMPROPER INSTALLATION OR IMPROPER TESTING, UNAUTHORIZED ATTEMPTS TO REPAIR, OR ANY OTHER CAUSE BEYOND THE RANGE OF THE INTENDED USE, OR BY ACCIDENT, FIRE, LIGHTNING OR OTHER HAZARD.



Disclaimer

(a) The Software is sold on an "AS IS" basis. Telrad Networks, its affiliates or its licensors MAKE NO WARRANTIES, WHATSOEVER, WHETHER EXPRESS OR IMPLIED, WITH RESPECT TO THE SOFTWARE AND THE ACCOMPANYING DOCUMENTATION. TELRAD NETWORKS SPECIFICALLY DISCLAIMS ALL IMPLIED WARRANTIES OF MERCHANTABILITY AND FITNESS FOR A PARTICULAR PURPOSE AND NON-INFRINGEMENT WITH RESPECT TO THE SOFTWARE. UNITS OF PRODUCT (INCLUDING ALL THE SOFTWARE) DELIVERED TO PURCHASER HEREUNDER ARE NOT FAULT-TOLERANT AND ARE NOT DESIGNED, MANUFACTURED OR INTENDED FOR USE OR RESALE IN APPLICATIONS WHERE THE FAILURE, MALFUNCTION OR INACCURACY OF PRODUCTS CARRIES A RISK OF DEATH OR BODILY INJURY OR SEVERE PHYSICAL OR ENVIRONMENTAL DAMAGE ("HIGH RISK ACTIVITIES"). HIGH RISK ACTIVITIES MAY INCLUDE, BUT ARE NOT LIMITED TO, USE AS PART OF ON-LINE CONTROL SYSTEMS IN HAZARDOUS ENVIRONMENTS REQUIRING FAIL-SAFE PERFORMANCE, SUCH AS IN THE OPERATION OF NUCLEAR FACILITIES, AIRCRAFT NAVIGATION OR COMMUNICATION SYSTEMS, AIR TRAFFIC CONTROL, LIFE SUPPORT MACHINES, WEAPONS SYSTEMS OR OTHER APPLICATIONS REPRESENTING A SIMILAR DEGREE OF POTENTIAL HAZARD. TELRAD NETWORKS SPECIFICALLY DISCLAIMS ANY EXPRESS OR IMPLIED WARRANTY OF FITNESS FOR HIGH RISK ACTIVITIES.

(b) PURCHASER'S SOLE REMEDY FOR BREACH OF THE EXPRESS WARRANTIES ABOVE SHALL BE REPLACEMENT OR REFUND OF THE PURCHASE PRICE AS SPECIFIED ABOVE, AT TELRAD NETWORKS'S OPTION. TO THE FULLEST EXTENT ALLOWED BY LAW, THE WARRANTIES AND REMEDIES SET FORTH IN THIS AGREEMENT ARE EXCLUSIVE AND IN LIEU OF ALL OTHER WARRANTIES OR CONDITIONS, EXPRESS OR IMPLIED, EITHER IN FACT OR BY OPERATION OF LAW, STATUTORY OR OTHERWISE, INCLUDING BUT NOT LIMITED TO WARRANTIES, TERMS OR CONDITIONS OF MERCHANTABILITY, FITNESS FOR A PARTICULAR PURPOSE, SATISFACTORY QUALITY, CORRESPONDENCE WITH DESCRIPTION, NON-INFRINGEMENT, AND ACCURACY OF INFORMATION GENERATED. ALL OF WHICH ARE EXPRESSLY DISCLAIMED. TELRAD NETWORKS' WARRANTIES HEREIN RUN ONLY TO PURCHASER, AND ARE NOT EXTENDED TO ANY THIRD PARTIES. TELRAD NETWORKS NEITHER ASSUMES NOR AUTHORIZES ANY OTHER PERSON TO ASSUME FOR IT ANY OTHER LIABILITY IN CONNECTION WITH THE SALE, INSTALLATION, MAINTENANCE OR USE OF ITS PRODUCTS.

Limitation of Liability

(a) TELRAD NETWORKS SHALL NOT BE LIABLE TO THE PURCHASER OR TO ANY THIRD PARTY, FOR ANY LOSS OF PROFITS, LOSS OF USE, INTERRUPTION OF BUSINESS OR FOR ANY INDIRECT, SPECIAL, INCIDENTAL, PUNITIVE OR CONSEQUENTIAL DAMAGES OF ANY KIND, WHETHER ARISING UNDER BREACH OF CONTRACT, TORT (INCLUDING NEGLIGENCE), STRICT LIABILITY OR OTHERWISE AND WHETHER BASED ON THIS AGREEMENT OR OTHERWISE, EVEN IF ADVISED OF THE POSSIBILITY OF SUCH DAMAGES.

(b) TO THE EXTENT PERMITTED BY APPLICABLE LAW, IN NO EVENT SHALL THE LIABILITY FOR DAMAGES HEREUNDER OF TELRAD NETWORKS OR ITS EMPLOYEES OR AGENTS EXCEED THE PURCHASE PRICE PAID FOR THE PRODUCT BY PURCHASER, NOR SHALL THE AGGREGATE LIABILITY FOR DAMAGES TO ALL PARTIES REGARDING ANY PRODUCT EXCEED THE PURCHASE PRICE PAID FOR THAT PRODUCT BY THAT PARTY (EXCEPT IN THE CASE OF A BREACH OF A PARTY'S CONFIDENTIALITY OBLIGATIONS).

Radio Frequency Interference Statement

The Base Transceiver Station (BTS) equipment has been tested and found to comply with the limits for a class A digital device, pursuant to ETSI EN 301 489-1 rules and Part 15 of the FCC Rules. These limits are designed to provide reasonable protection against harmful interference when the equipment is operated in commercial, business and industrial environments. This equipment generates, uses, and can radiate radio frequency energy



and, if not installed and used in accordance with the instruction manual, may cause harmful interference to radio communications. Operation of this equipment in a residential area is likely to cause harmful interference in which case the user will be required to correct the interference at the user's own expense.



FCC and Industry Canada Radiation Hazard Warning

To comply with Industry Canada exposure requirements, and FCC RF exposure requirements in Section 1.1307 and 2.1091 of FCC Rules, the antenna used for this transmitter must be fixed-mounted on outdoor permanent structures with a separation distance of at least 200 cm from all persons.

Industry Canada Statement

Users can obtain Canadian information on RF exposure and compliance from the Canadian Representative:

Nick Dewar

Nick.Dewar@Telrad.com

Canadian Radio Standards Specifications (RSS) Compliance Statement

This device has been designed to operate with the antennas listed in [Section 1.4.7](#), and having a maximum gain of 18 dBi. Antennas not included in this list or having a gain greater than 18 dBi are strictly prohibited for use with this device.

To reduce potential radio interference to other users, the antenna type and its gain should be so chosen that the Equivalent Isotropically Radiated Power (EIRP) is not more than that permitted for successful communication.

R&TTE Compliance Statement

This equipment complies with the appropriate essential requirements of Article 3 of the R&TTE Directive 1999/5/EC.

Safety Considerations - General

For the following safety considerations, “Instrument” means the BreezeCOMPACT units' components and their cables.

Grounding

BTS chassis is required to be bonded to protective grounding using the bonding stud or screw provided with each unit.

Safety Considerations - DC Powered Equipment



CAUTION

Risk of electric shock and energy hazard.

ATTENTION

Risque de décharge électrique et d'electrocution.

Restricted Access Area: The DC powered equipment should only be installed in a Restricted Access Area.

Installation Codes: The equipment must be installed according to the latest edition of the country national electrical codes. For North America, equipment must be installed in accordance with the US National Electrical Code and the Canadian Electrical Code.

Zone d'Accès Limité: L'alimentation en courant continue doit être installée dans une zone a accès limité

Normes d'installation: les équipements doivent être installes d'après les dernières normes en vigueur. Pour l'Amérique du nord les équipements doivent être installés d'après les normes électriques nationales US et les normes électriques Canadiennes.



Overcurrent Protection: A readily accessible Listed branch circuit overcurrent protective device, rated 10A must be incorporated in the building wiring.

CAUTION: This equipment is designed to permit connection between the earthed conductor of the DC supply circuit and the grounding conductor at the equipment. See installation instructions.

- The equipment must be connected directly to the DC Supply System grounding electrode conductor.
- All equipment in the immediate vicinity must be grounded in the same way, and not be grounded elsewhere.
- The DC supply system is to be local, i.e. within the same premises as the equipment.
- There shall be no disconnect device between the grounded circuit conductor of the DC source (return) and the point of connection of the grounding electrode conductor.

Protection de surintensité: Une protection de surintensité de 10A doit être installée sur le circuit d'alimentation.

ATTENTION: Cet équipement est prévu pour permettre une mise à la terre entre le courant continu et le reste de l'installation. Voir les instructions d'installation.

- L'appareil doit être connecté à la terre de l'alimentation en courant continu.
- Tout appareil dans la proximité immédiate doit être connecté à la terre de la même manière et pas autrement.
- L'alimentation du système en courant continu doit être local et remplir les mêmes conditions que le matériel.
- Le circuit de terre doit être ininterrompu entre la source et les différents appareils

Caution

To avoid electrical shock, do not perform any servicing unless you are qualified to do so.

Pour éviter tout choc électrique ne pas intervenir sur les circuits électriques si vous n'êtes pas qualifié pour

Line Voltage

Before connecting this instrument to the power line, make sure that the voltage of the power source matches the requirements of the instrument.

Laser



CLASS 1 LASER PRODUCT

The system can be equipped with Class 1 laser products, which comply with IEC 60825-1, IEC 60825-2 and UL recognized laser or CDRH CFR Title 21, part 1040.

The system does not emit hazardous light, and the beam is totally enclosed during normal operation, as long as the equipment is operated in accordance with the applicable safety instructions

APPAREIL A` LASER DE CLASSE 1

Classe du Laser

Le système peut être équipé d'un laser de classe 1 selon la norme IEC 60825-1, IEC 60825-2 et reconnu comme UL laser ou CDRH CFR titre 21 ,partie 1040.

Le système n'émet pas de lumière apparente et le rayon est entièrement protégé pendant l'utilisation normal du système par l'utilisateur tant que les appareils sont utilisés en suivant les instructions de sécurité.



Laser Safety Statutory Warning

All personnel involved in equipment installation, operation, and maintenance must be aware that laser radiation is invisible. Therefore, although protective devices generally prevent directly exposure to the beam, personnel must strictly observe the applicable safety precautions, and in particular, must avoid staring into optical connectors, either directly or using optical instruments.

Remember that observing safety precautions is not a matter of personal choice; ignoring safety puts all people within the line-of-sight in danger.

Précautions de sécurité réglementaire pour laser

Tout personnel impliqué dans l'installation, le fonctionnement et la maintenance de l'installation doivent savoir que les radiations laser sont invisibles. Donc, bien que généralement les protections évitent tout contact direct avec les rayons émis, le personnel doit observer strictement les précautions de sécurité et en particulier, les connecteurs optiques, aussi bien directement ou avec des instruments d'optique.

Souvenez vous que remplir les précautions de sécurité n'est en aucun cas un choix personnel; ignorer les règles de sécurité mets toutes les personnes en présence en danger.

Radio

The instrument transmits radio energy during normal operation. To avoid possible harmful exposure to this energy, do not stand or work for extended periods of time in front of its antenna. The long-term characteristics or the possible physiological effects of radio frequency electromagnetic fields have not been yet fully investigated.

Outdoor Units and Antennas Installation and Grounding

Ensure that outdoor units, antennas and supporting structures are properly installed to eliminate any physical hazard to either people or property. Make sure that the installation of the outdoor unit, antenna and cables is performed in accordance with all relevant national and local building and safety codes. Even where grounding is not mandatory according to applicable regulation and national codes, it is highly recommended to ensure that the outdoor unit and the antenna mast are grounded and suitable lightning protection devices are used so as to provide protection against voltage surges and static charges. In any event, Telrad Networks is not liable for any injury, damage or regulation violations associated with or caused by installation, grounding or lightning protection.

Disposal of Electronic and Electrical Waste



Disposal of Electronic and Electrical Waste

Pursuant to the WEEE EU Directive electronic and electrical waste must not be disposed of with unsorted waste. Please contact your local recycling authority for disposal of this product.



Important Notice

This user manual is delivered subject to the following conditions and restrictions:

- This manual contains proprietary information belonging to Telrad Networks Ltd. Such information is supplied solely for the purpose of assisting properly authorized users of the respective Telrad Networks products.
- No part of its contents may be used for any other purpose, disclosed to any person or firm or reproduced by any means, electronic and mechanical, without the express prior written permission of Telrad Networks Ltd.
- The text and graphics are for the purpose of illustration and reference only. The specifications on which they are based are subject to change without notice.
- The software described in this document is furnished under a license. The software may be used or copied only in accordance with the terms of that license.
- Information in this document is subject to change without notice. Corporate and individual names and data used in examples herein are fictitious unless otherwise noted.
- Telrad Networks reserves the right to alter the equipment specifications and descriptions in this publication without prior notice. No part of this publication shall be deemed to be part of any contract or warranty unless specifically incorporated by reference into such contract or warranty.
- The information contained herein is merely descriptive in nature, and does not constitute an offer for the sale of the product described herein.
- Any changes or modifications of equipment, including opening of the equipment not expressly approved by Telrad Networks Ltd. will void equipment warranty and any repair thereafter shall be charged for. It could also void the user's authority to operate the equipment.

Some of the equipment provided by Telrad Networks and specified in this manual, is manufactured and warranted by third parties. All such equipment must be installed and handled in full compliance with the instructions provided by such manufacturers as attached to this manual or provided thereafter by Telrad Networks or the manufacturers. Non-compliance with such instructions may result in serious damage and/or bodily harm and/or void the user's authority to operate the equipment and/or revoke the warranty provided by such manufacturer.



About This Manual

This manual describes the BreezeCOMPACT solution, and details how to install, operate and manage the BTS equipment.

This manual is intended for technicians responsible for installing, setting and operating the BreezeCOMPACT BTS equipment, and for system administrators responsible for managing the system.

This manual contains the following chapters and appendices:

- **Chapter 1 - System description:** Describes the BreezeCOMPACT system.
- **Chapter 2 - Installation:** Describes how to install the BTS equipment.
- **Chapter 3 - Commissioning:** Describes how to configure basic parameters and validate units' operation.
- **Chapter 4 - Operation and Administration:** Describes how to use the Monitor program for configuring parameters, checking system status and monitoring performance.

Contents

Chapter 1 - System Description	1
1.1 About WiMAX	2
1.1.1 Introduction to WiMAX	2
1.1.2 WiMAX Network Reference Model	2
1.2 The BreezeCOMPACT Solution	9
1.2.1 BreezeCOMPACT Highlights	9
1.2.2 Network Architectures	9
1.2.3 System Topologies	10
1.2.4 Antennas	12
1.2.5 GPS	12
1.3 Element Management Systems	14
1.4 Specifications	15
1.4.1 Modem & Radio	15
1.4.2 Data Communication (Ethernet Interfaces)	15
1.4.3 Configuration and Management	17
1.4.4 Standards Compliance, General	17
1.4.5 Environmental	18
1.4.6 Mechanical and Electrical	18
1.4.7 Antennas	19
1.4.8 BMAX-4M-GPS Receiver Specifications	24
Chapter 2 - Commissioning	25
2.1 Introduction	26
2.2 BreezeCOMPACT Installation	27
2.3 System Initial Verification	28
2.4 Configuring Parameters Required for Management Connectivity	29
2.4.1 Configuring the BTS Number	29
2.4.2 Configuring the Management Interface Connectivity Mode Parameter	29
2.4.3 Configuring the IP Interfaces Parameters	29
2.4.4 Configuring the L1 and L2 Parameters (if necessary)	30

2.4.5	Configuring the SNMP Authorized Manager and Traps Manager	30
2.4.6	Applying the Configuration	31
2.5	Activating the Unit	32
2.5.1	Creating the BS	32
2.5.2	Defining the Antenna(s)	34
2.5.3	Configuring Radio Cluster Parameters	34
2.5.4	Configuring Antenna Associations	35
2.5.5	Applying the Configuration	35
Chapter 3	- Operation and Administration	36
3.1	BTS System Management	37
3.2	The Monitor Program.....	38
3.2.1	Accessing the Monitor Program.....	38
3.2.2	Using the Monitor Program.....	39
3.3	IP Addresses Configuration.....	41
3.3.1	IP Address Configuration Restrictions	41
3.3.2	IP Subnets	41
3.4	The Main Menu.....	42
3.5	BTS Menu.....	43
3.5.1	General	43
3.5.2	Connectivity	44
3.5.3	Unit Control	50
3.5.4	Management.....	54
3.6	Sector Menu	58
3.6.1	Sector Definition.....	58
3.6.2	Radio Cluster.....	58
3.6.3	Antenna Association.....	59
3.7	BS Menu	60
3.7.1	Add	60
3.7.2	Select.....	62
3.8	Chassis Menu	82
3.8.1	General	82
3.8.2	Ports Control.....	82
3.9	GPS Menu	84

3.9.1	General Configuration.....	84
3.9.2	Inventory & Statuses.....	86
3.10	RH Menu.....	88
3.10.1	General	88
3.10.2	Ports	89
3.11	Antenna Menu	90
3.11.1	Antenna Number.....	90
3.11.2	Antenna Product Type	90
3.11.3	Mechanical Down Tilt.....	90
3.11.4	Electrical Down Tilt	90
3.11.5	Longitude.....	91
3.11.6	Latitude	91
3.11.7	Tower Height	91
3.11.8	Heading.....	91
3.11.9	Cable Loss.....	91

Figures

Figure 1-1: Mobile WiMAX Network Reference Model 3

Figure 1-2: ASN Reference Model containing Multiple ASN-GWs..... 3

Figure 1-3: Centralized Network Reference Model..... 6

Figure 1-4: Distributed Network Reference Model..... 7

Figure 1-5: One Sector, One Carrier 11

Figure 1-6: One Sector, Dual Carrier 11

Figure 1-7: Two Sectors, Two Carriers (One Carrier per Sector)..... 12

Tables

Table 1-1: General Modem & Radio Specifications.....	15
Table 1-2: Data Communication (Ethernet Interfaces).....	15
Table 1-3: Configuration and Management	17
Table 1-4: Standards Compliance, General	17
Table 1-5: Environmental Specifications.....	18
Table 1-6: Mechanical & Electrical Specifications, COMPACT units.....	18
Table 1-7: Mechanical & Electrical Specifications, COMPACT HP units.....	18
Table 1-8: Attached Antenna 3.3-3.8 DDS 65° (P.N. 300726) Specifications	19
Table 1-9: ANT,BS,3.3-3.8GHz, DS,Sec.65°,16.5dBi min. (P.N. 300644) Specifications	20
Table 1-10: ANT,BS,3.3-3.8GHz, DS,Sec.90°,15.5dBi min. (P.N. 300645) Specifications	21
Table 1-11: ANT-DDP-65°-3.3-3.8GHz (P.N. 300736) Specifications	22
Table 1-12: ANT-DDP-90°-3.3-3.8GHz (P.N. 300719) Specifications	23
Table 1-13: BMAX-4M-GPS Receiver, Mechanical & Electrical Specifications.....	24
Table 2-1: BreezeCOMPACT LEDs.....	28
Table 3-1: First Zone Minimum Size Recommended Value Range.....	67
Table 3-2: Calculating the Upper Limit Value (Y) for Minimum and Maximum Size	68
Table 3-3: DL:UL Ratios	70
Table 3-4: Functionality of Allowed Ducting Mitigation Modes, 5/10 MHz BS Bandwidth	73
Table 3-5: Functionality of Allowed Ducting Mitigation Modes, 7 MHz BS Bandwidth	74

Chapter 1 - System Description

In This Chapter:

- "About WiMAX" on page 2
- "The BreezeCOMPACT Solution" on page 9
- "Element Management Systems" on page 14
- "Specifications" on page 15



1.1 About WiMAX

1.1.1 Introduction to WiMAX

Emanating from the broadband world and using all-IP architecture, mobile WiMAX is the leading technology for implementing personal broadband services. No other technology offers a full set of chargeable and differentiated voice, data, and premium video services in a variety of wireless fashions - fixed, portable and mobile - that increase revenue and reduce subscriber churn.

WiMAX technology is the solution for many types of high-bandwidth applications at the same time across long distances and will enable service carriers to converge the all-IP-based network for triple-play services data, voice, and video.

WiMAX with its QoS support, longer reach, and high data capacity is positioned for fixed broadband access applications in rural areas, particularly when distance is too large for DSL and cable, as well as in urban/suburban areas of developing countries. Among applications for residential are high speed Internet, Voice Over IP telephony and streaming video/online gaming with additional applications for enterprise such as Video conferencing, Video surveillance and secured Virtual Private Network (with need for high security). WiMAX technology allows covering applications with media content requesting more bandwidth.

WiMAX allows portable and mobile access applications, with incorporation in notebook computers and PDAs, allowing for urban areas and cities to become "metro zones" for portable and mobile outdoor broadband wireless access. As such WiMAX is the natural complement to 3G networks by offering higher bandwidth and to Wi-Fi networks by offering broadband connectivity in larger areas.

The WiMAX Forum is an organization of leading operators and communications component and equipment companies. The WiMAX Forum's charter is to promote and certify the compatibility and interoperability of broadband wireless access equipment that conforms to the Institute for Electrical and Electronics Engineers (IEEE) 802.16 and ETSI HiperMAN standards. The ultimate goal of the WiMAX Forum is to accelerate the introduction of cost-effective broadband wireless access services into the marketplace. Standards-based, interoperable solutions enable economies of scale that, in turn, drive price and performance levels unachievable by proprietary approaches, making WiMAX Forum Certified products.

1.1.2 WiMAX Network Reference Model

Figure 1-1 and Figure 1-2 show the basic mobile WiMAX network architecture, with a single ASN-GW and with multiple ASN-GWs, as defined by the WiMAX Forum NWG

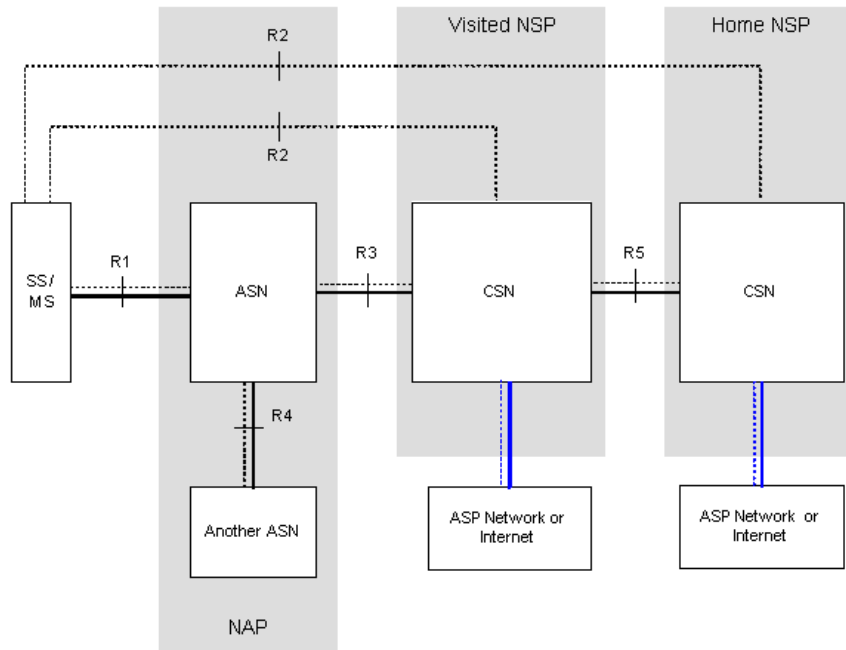

Figure 1-1: Mobile WiMAX Network Reference Model

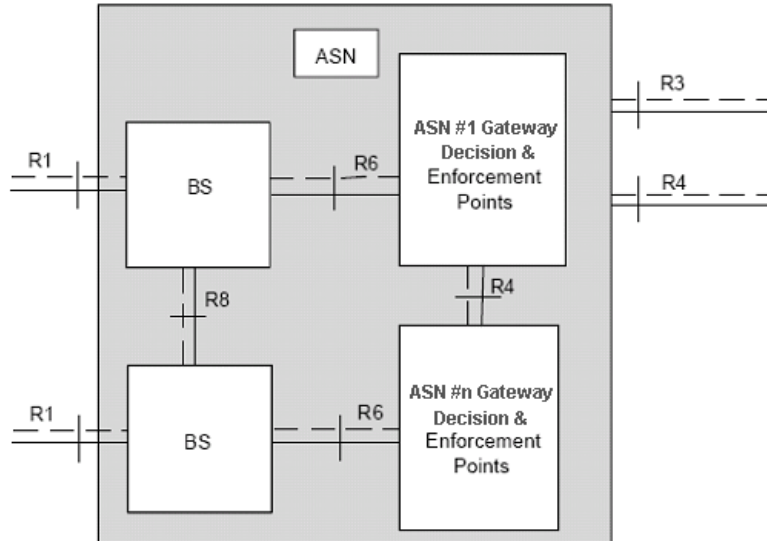

Figure 1-2: ASN Reference Model containing Multiple ASN-GWs

The various components and entities involved in the networking architecture are:

1.1.2.1 Access Service Network (ASN)

An ASN is defined as a complete set of network functions needed to provide radio access to a WiMAX subscriber. The ASN provides the following mandatory functions:



- WiMAX Layer-2 (L2) connectivity with WiMAX mobile station (MS)
- Transfer of AAA messages to the WiMAX subscriber's home network service provider (H-NSP) for authentication, authorization and session accounting for subscriber sessions
- Network discovery and selection of the WiMAX subscriber's preferred NSP
- Relay functionality for establishing Layer-3 (L3) connectivity with a WiMAX MS (i.e. IP address allocation)
- Radio resource management
- ASN-CSN tunneling
- ASN anchored mobility

An ASN is comprised of network elements such as one or more base transceiver stations and one or more ASN gateways. An ASN may be shared by more than one connectivity service network (CSN).

1.1.2.2 Connectivity Service Network (CSN)

A CSN is defined as a set of network functions that provide IP connectivity services to WiMAX subscribers. A CSN may offer the following functions:

- MS IP address and endpoint parameter allocation for user sessions
- Internet access
- AAA proxy or server
- Policy and admission control based on user subscription profiles
- ASN-CSN tunneling support
- WiMAX subscriber billing and inter-operator settlement
- WiMAX services such as location-based services, connectivity for peer-to-peer services, provisioning, authorization and/or connectivity to IP multimedia services, and facilities to support lawful intercept services such as those compliant with Communications Assistance Law Enforcement Act (CALEA) procedures

A CSN is comprised of network elements such as routers, proxy/servers, user databases, and inter-working gateway devices.

1.1.2.3 Network Access Provider (NAP)

An NAP is a business entity that provides WiMAX radio access infrastructure to one or more WiMAX network service providers (NSPs). A NAP implements this infrastructure using one or more ASNs.

1.1.2.4 Network Service Provider (NSP)

An NSP is a business entity that provides IP connectivity and WiMAX services to WiMAX subscribers compliant with the established service level agreement. The NSP concept is an extension of the Internet service provider (ISP) concept, providing network services beyond Internet access. To provide these



services, an NSP establishes contractual agreements with one or more NAPs. An NSP may also establish roaming agreements with other NSPs and contractual agreements with third-party application providers (e.g. ASP, ISP) for the delivery of WiMAX services to subscribers. From a WiMAX subscriber standpoint, an NSP may be classified as a home or visited NSP.

1.1.2.5 Base Station (BS)

The WiMAX BS is an entity that implements the WiMAX MAC and PHY in compliance with the IEEE 802.16e standard. A BS operates on one frequency assignment, and incorporates scheduler functions for uplink and downlink resources.

The basic functionality of the BS includes:

- IEEE 802.16e OFDMA PHY/MAC entity
- R6 and R8 functionality according to NWG definitions
- Extensible Authentication Protocol (EAP) relay
- Control message authentication
- User traffic authentication and encryption
- Handover management
- QoS service flow management entity

1.1.2.6 ASN Gateway (ASN-GW)

The ASN-GW is a network entity that acts as a gateway between the ASN and CSN. The ASN functions hosted in an ASN-GW may be viewed as consisting of two groups - the decision point (DP) and enforcement point (EP). The EP includes bearer plane functions, and the DP includes non-bearer plane functions.

The basic DP functionality of the ASN-GW includes:

- Implementation of EAP Authenticator and AAA client
- Termination of RADIUS protocol against the selected CSN AAA server (home or visited AAA server) for MS authentication and per-MS policy profile retrieval
- Storage of the MS policy profile
- Generation of authentication key material
- QoS service flow authorization entity
- AAA accounting client

The basic EP functionality of the ASN-GW includes:

- Classification of downlink data into generic routing encapsulation (GRE) tunnels
- Packet header suppression functionality
- DHCP functionality

■ Handover functionality

The WIMAX Forum NWG has adopted two different approaches for ASN architecture - centralized and distributed: In the centralized approach there is at least one central ASN-GW, and the BTS operates in transparent mode, as shown in [Figure 1-3](#).

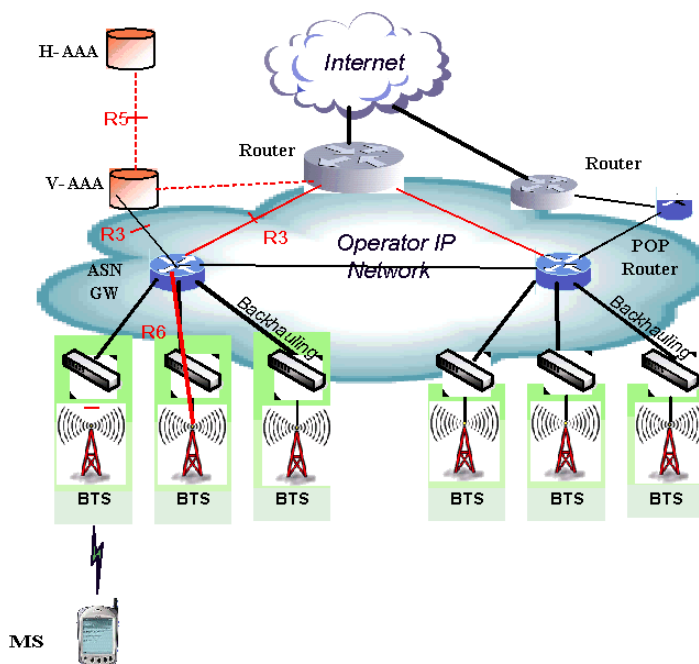

Figure 1-3: Centralized Network Reference Model

In the distributed approach, the BTS operates in ASN-GW mode, as shown in Figure 1-4.

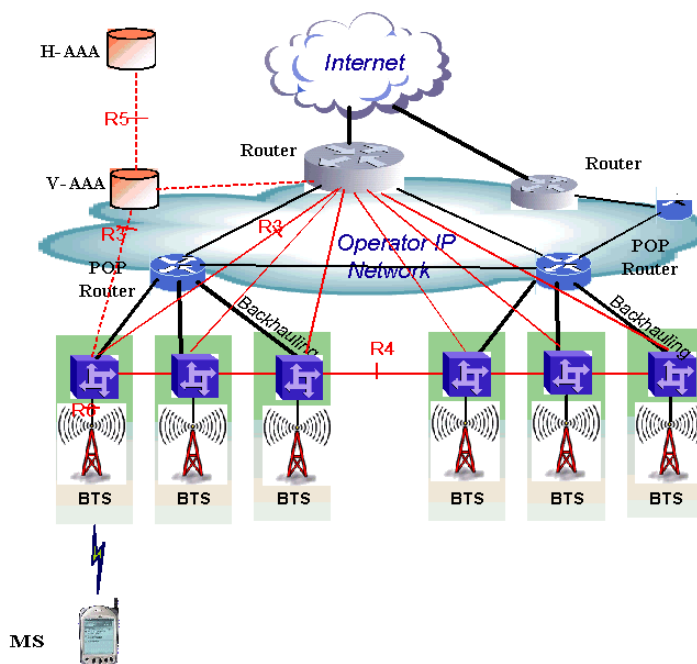

Figure 1-4: Distributed Network Reference Model

Telrad believes in providing operators with the flexibility to select the mobile WiMAX network topology that best suits their needs and existing network architecture. Therefore, 4Motion is designed to support both distributed and centralized topology approaches according to WiMAX Forum NWG profile C.

1.1.2.7 Reference Points

- **Reference point R1** consists of the protocols and procedures between the MS and ASN as per the air-interface (PHY and MAC) specifications (IEEE 802.16e).
- **Reference point R2** consists of protocols and procedures between the MS and CSN associated with authentication, services authorization and IP host configuration management. This reference point is logical in that it does not reflect a direct protocol interface between the MS and CSN. The authentication part of reference point R2 runs between the MS and CSN operated by the home NSP, however, the ASN and CSN operated by the visited NSP may partially process the aforementioned procedures and mechanisms. Reference point R2 might support IP host configuration management running between the MS and CSN (operated by either the home NSP or visited NSP).
- **Reference point R3** consists of the set of control plane protocols between the ASN and CSN to support AAA, policy enforcement and mobility management capabilities. It also encompasses the bearer plane methods (e.g. tunneling) to transfer user data between the ASN and CSN.
- **Reference point R4** consists of the set of control and bearer plane protocols originating/terminating in various functional entities of an ASN that coordinate MS mobility between ASNs and ASN-GWs. R4 is the only interoperable reference point between similar or heterogeneous ASNs.



- **Reference point R5** consists of the set of control plane and bearer plane protocols for internetworking between the CSN operated by the home NSP and that operated by a visited NSP.
- **Reference point R6** consists of the set of control and bearer plane protocols for communication between the BS and ASN-GW. The bearer plane consists of an intra-ASN data path between the BS and ASN gateway. The control plane includes protocols for data path establishment, modification and release control in accordance with the MS mobility events.
- **Reference point R8** consists of the set of control plane message flows and optional bearer plane data flows between the base stations to ensure a fast and seamless handover. The bearer plane consists of protocols that allow data transfer between base stations involved in the handover of a certain MS.

It is important to note that all reference points are logical and do not necessarily imply a physical or even direct connection. For instance, the R4 reference point between ASN-GWs might be implemented across the NAP internal transport IP network, in which case R4 traffic might traverse several routers from the source to the destination ASN-GW.



1.2 The BreezeCOMPACT Solution

1.2.1 BreezeCOMPACT Highlights

BreezeCOMPACT family includes all-outdoor single box base transceiver stations (BTSs) enabling easy installation and maintenance and reduced Total Cost of Ownership (TCO). The products family includes the small, lightweight BreezeCOMPACT supporting transmit power of up to 30 dBm and the slightly larger BreezeCOMPACT HP (High Power) supporting transmit power of up to 38 dBm.

BreezeCOMPACT enhances Telrad's 4Motion product portfolio of BreezeMAX Macro and Micro BTS systems with a compact all-outdoor platform enabling extended and flexible installation capabilities while sustaining 4Motion leading technological advantages and ecosystem.

BreezeCOMPACT is a weatherized carrier-class WiMAX 802.16e platform, based on Software Defined Radio (SDR) that is SW upgradable for new technologies such as Time-Division Long-Term Evolution (TD-LTE). It is an integral part of 4Motion end-to-end solution. BreezeCOMPACT BTS complements Telrad's Macro BTS products for coverage and capacity extension as well as rural deployment scenarios.

BreezeCOMPACT is a reliable platform utilizing the mature field-proven 4Motion modules and ecosystem elements (e.g. ASN-GW, AAA, and WiMAX™ devices), hence delivering high product availability.

Portable and mobile subscribers can connect to BreezeCOMPACT base station through various end-user terminals such as USB dongles, Self Installed (SI) Residential Gateways (RGW), and Outdoor CPEs.

Telrad's COMPACT family and 4Motion Micro and Macro solutions share similar functionality with same ecosystem, allowing flexible mix & match approach to address various operator deployment needs.

Telrad believes that compliance with standard-driven open architecture protects the infrastructure investment, and opens the system to a variety of fully interoperable end-user devices. As such, 4Motion is designed with open architecture and interfaces according to the WiMAX Forum networking working group (NWG) profile C, which supports openness and enables flat as well as hierarchical topologies. In addition, by keeping the radio resource management functionality in the Base Transceiver Station only, Profile C delivers a faster, optimized handover mechanism.

1.2.2 Network Architectures

BreezeCOMPACT supports different network architectures:

- External ASN-GW
-
- Embedded ASN-GW Centralized Authentication

INFORMATION



In the current release only External ASN-GW network architecture is supported.



Following is a description of each of these working modes:

1.2.2.1 External ASN-GW

The ASN-GW is a separate entity (centralized architecture) that communicates with the BTS over R6 interface. Service components (Service Profiles and Service Flows) are configured in the external ASN-GW. MS authentication and services provisioning are managed by a centralized AAA server, based on user credentials (user name and password).

1.2.2.2 Embedded ASN-GW Centralized Authentication

The ASN-GW functionality resides in the BTS (distributed architecture). Service components (Service Profiles and Service Flows) are configured locally in the BTS. MS authentication and service provisioning are managed centrally by an external AAA server, based on user credentials (user name and password).

1.2.3 System Topologies

BreezeCOMPACT supports different system topologies:

- One Sector, One Carrier
- One Sector, Dual Carrier
- Two Sector, Two Carriers (One Carrier per Sector)

INFORMATION



In the current release only One Sector, One Carrier topology is supported.

In all relevant topologies, COMPACT units support 4Rx by 4Tx radio configurations, and COMPACT HP units support 4Rx by 2Tx radio configurations.

Following is a description of each of these topologies:

1.2.3.1 One Sector, One Carrier

This is the basic configuration based on a single BS, supporting a single sector with a bandwidth of 5, 7, or 10 MHz.

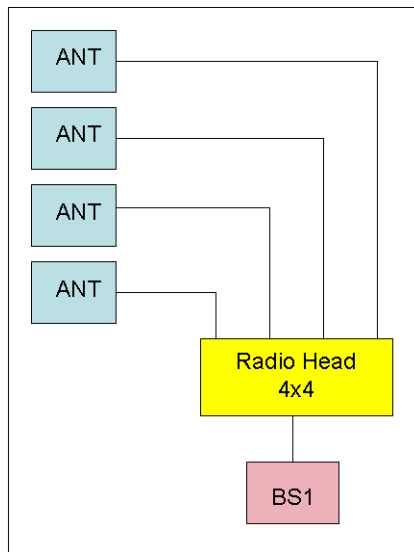

Figure 1-5: One Sector, One Carrier

1.2.3.2 One Sector, Dual Carrier

Two BSs support a single sector using two different carriers with a total bandwidth of 20 (10+10), 14 (7+7), or 10 (5+5) MHz.

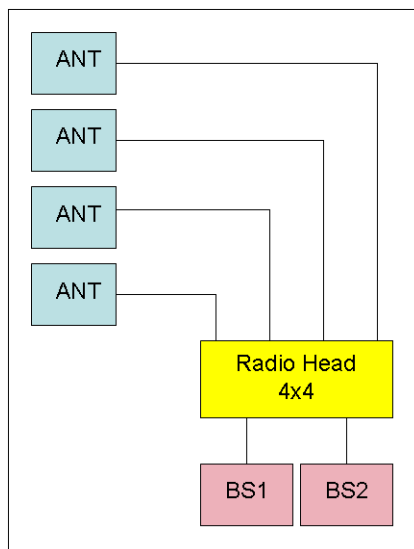

Figure 1-6: One Sector, Dual Carrier

1.2.3.3 Two Sector, Two Carriers (One Carrier per Sector)

Two BSs support two sectors, each with a bandwidth of 5, 7, or 10 MHz.

Not applicable for Compact HP.

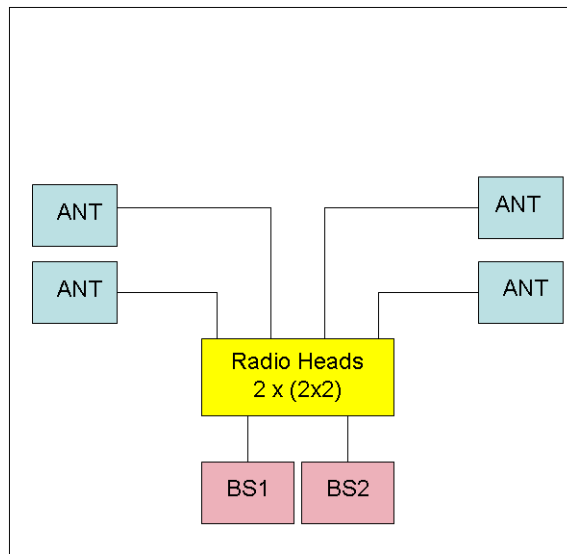

Figure 1-7: Two Sectors, Two Carriers (One Carrier per Sector)

1.2.4 Antennas

In the system architecture, the antenna is approached as an independent element. This provides the operator with the flexibility to select the antennas source according to its supplier policy. To ensure the availability of antennas that complement the solution, Telrad works closely with several antenna suppliers to ensure availability of antennas that comply with its requirements.

In cases where the operator prefers other antenna vendors, Telrad can provide a recommended antenna specification based on the required antennas types.

Antennas may support mechanical down-tilt (MDT) using a suitable mounting kit, or electrical down-tilt (EDT) that may be either fixed or adjustable using a special adjustment screw.

In addition to a range of standard commercial antennas, Telrad offers also a special attached antenna designed for convenient installation on top of the COMPACT unit. For the COMPACT HP unit, a special mounting kit allows installation of a standard antenna on top of the unit to minimize the space required for installation.

For details on antennas offered by Telrad refer to [“Antennas” on page 19](#).

1.2.5 GPS

GPS is used to synchronize the air link frames of Intra-site and Inter-site located Base Transceiver Stations to ensure that in all Base Stations the air frame will start at the same time, and that all Base Stations will switch from transmit (downlink) to receive (uplink) at the same time. This synchronization is necessary to prevent Intra-site and Inter-site interference and Base Stations saturation (assuming that all Base Stations are operating with the same frame size and with the same DL/UL ratio).



The all-outdoor GPS Receiver is a pole mountable GPS receiver and antenna in a single environmentally protected enclosure that is powered from the unit. GPS signals chaining (not supported in current release) enables using a single GPS receiver for several collocated units.



1.3 Element Management Systems

The end-to-end IP-based architecture of the system enables full management of all components, using standard management tools. An SNMP agent in the NPU implements proprietary MIBs for remote setting of operational modes and parameters of the Base Transceiver Station equipment. Security features incorporated in the equipment restrict the access for management purposes.

Telrad offers the following management tools:

- **AlvariSTAR:** A comprehensive carrier-class Element Management System (EMS) for Broadband Wireless Access systems. AlvariSTAR is designed for today's most advanced Network Operation Centers (NOCs), providing the network Operation, Administration and Maintenance (OA&M) staff and managers with all the network surveillance, monitoring and configuration and service provisioning capabilities required to effectively manage the network while keeping the resources and expenses at a minimum.

AlvariSTAR offers the network's OA&M staff with a unified, scalable and distributable management system. Utilizing distributed client-server architecture, the user is provided with a robust, scalable and fully redundant management system in which all single points of failure can be avoided.

- **AlvariCRAFT:** With all relevant feature and capabilities of AlvariSTAR, this utility simplifies the installation and maintenance of network elements by easily enabling complete management functionality for one unit at a time.



1.4 Specifications

1.4.1 Modem & Radio

Table 1-1: General Modem & Radio Specifications

Item	Description
Frequency Band, Maximum Tx Power and Ports Configuration	Medium Power Radio Heads (COMPACT): <ul style="list-style-type: none"> ■ 3400-3675 MHz, 27 dBm, 4Rx by 4Tx (first generation units) ■ 3300-3800 MHz, 30 dBm, 4Rx by 4Tx High Power Radio Heads (COMPACT HP): <ul style="list-style-type: none"> ■ 3400-3600 MHz, 4Rx by 2Tx
Central Frequency Resolution	0.125 MHz
Operation Mode	TDD
Channel Bandwidth	<ul style="list-style-type: none"> ■ 5 MHz ■ 7 MHz ■ 10 MHz
Tx Power Control Range	10 dB, in 1 dB steps
Tx Power Accuracy	+/- 1 dB
Maximum Input Power @ antenna port	-45 dBm before saturation, -35 dBm before damage
Noise Figure	5 dB
Modulation	OFDM modulation, 1024/512 FFT points; QPSK, QAM16, QAM64
Access Method	OFDMA
FEC	Convolutional Turbo Coding: 1/2, 3/4 for QPSK and QAM16. 1/2, 2/3, 3/4, 5/6 for QAM64

1.4.2 Data Communication (Ethernet Interfaces)

Table 1-2: Data Communication (Ethernet Interfaces)

Item	Description
Standard Compliance	IEEE 802.3 CSMA/CD
DAT 1 (optional, if an SFP is installed)	1000 Mbps Base-X optical fiber interface, Half/Full Duplex with Auto Negotiation.



Table 1-2: Data Communication (Ethernet Interfaces)

Item	Description
DAT 2	100/1000 Mbps Base-T twisted-pair electrical interface, Half/Full Duplex with Auto Negotiation.
DAT 3	10/100 Mbps Base-T twisted-pair electrical interface, Half/Full Duplex with Auto Negotiation.



1.4.3 Configuration and Management

Table 1-3: Configuration and Management

Item	Description
Management (Out Of Band, In Band)	<ul style="list-style-type: none"> ■ SNMP ■ Telnet
SNMP Agents	SNMP Ver. 2 client MIB II (RFC 1213), Private MIBs
Software Upgrade	Using TFTP
Configuration Upload/Download	Using TFTP

1.4.4 Standards Compliance, General

Table 1-4: Standards Compliance, General

Type	Standard
EMC	<ul style="list-style-type: none"> ■ ETSI EN 301 489-1/4 ■ FCC Part 15
Safety	<ul style="list-style-type: none"> ■ EN60950-1 (CE) ■ UL 60950-1 (US/C)
Environmental	ETS 300 019: <ul style="list-style-type: none"> ■ Part 2-1 T 1.2 & part 2-2 T 2.3 for indoor & outdoor ■ Part 2-3 T 3.2 for indoor ■ Part 2-4 T 4.1E for outdoor
Radio	<ul style="list-style-type: none"> ■ ETSI EN 302 326 ■ FCC Part 90 Subpart Z* ■ IC RSS-192 issue1* ■ IC RSS-197 issue 3* In the current release FCC and IC standards are not applicable for COMPACT HP units



1.4.5 Environmental

Table 1-5: Environmental Specifications

Type	Details
Operating Temperature	-40°C to 55°C
Operating Humidity	5%-95%, weather protected

1.4.6 Mechanical and Electrical

1.4.6.1 COMPACT

Table 1-6: Mechanical & Electrical Specifications, COMPACT units

Item	Description
Dimensions	242.7 x 343 x 166.9 mm
Weight	8.2 Kg
Power Input	-40 to -60 VDC
Power Consumption	27 dBm units: 105W maximum (at 70% Tx/Rx duty cycle), 125W peak. 30 dBm units: 118W maximum (at 70% Tx/Rx duty cycle), 142W peak.

1.4.6.2 COMPACT HP

Table 1-7: Mechanical & Electrical Specifications, COMPACT HP units

Item	Description
Dimensions	280 x 510 x 220 mm
Weight	19.5 Kg
Power Input	-40 to -60 VDC
Power Consumption	186W maximum (at 70% Tx/Rx duty cycle), 225W peak



1.4.7 Antennas

1.4.7.1 Attached, 3.3-3.8 GHz, 4 Ports 65° Double Dual Slant (xx)

Applicable only for COMPACT installations.

Table 1-8: Attached Antenna 3.3-3.8 DDS 65° (P.N. 300726) Specifications

Item	Description
Frequency Band (MHz)	3300-3800
Number of Elements	4
Polarization	Linear, +/-45°
Gain (dB)	18
Azimuth Beamwidth (degrees)	65
Elevation Beamwidth (degrees)	6.5
Maximum Power (W)	150
Cross-polarization Discrimination (dB)	>15
Front-to-Back Ratio (dB)	>30
Electrical Downtilt Range (degrees)	0
Isolation Between Ports (dB)	>30
Return Loss (dB)	>15
RF Interface Impedance (Ohm)	50
RF Connectors	4 x N-Type jacks with RF cable tails
Dimensions (mm)	720x 266 x 52
Weight (Kg)	4
Regulatory Compliance	RoHS Compliance

**1.4.7.2 3.3 -3.8 GHz, 2 Ports 65° Dual Slant (x)****Table 1-9: ANT,BS,3.3-3.8GHz, DS,Sec.65°,16.5dBi min. (P.N. 300644) Specifications**

Item	Description
Frequency Band (MHz)	3300-3800
Number of Elements	2
Polarization	Linear, +/-45°
Gain	16.5dBi +/- 0.5dB
VSWR	1.5:1 (max)
Azimuth Beamwidth (degrees)	65 +/-5
Elevation Beamwidth (degrees)	6 +/-1
Maximum Power (W)	50
Cross-polarization Discrimination (dB)	-15
Front-to-Back Ratio (dB)	>25
Isolation Between Ports (dB)	>25
RF Interface Impedance (Ohm)	50
Lightning Protection	DC grounded
RF Connectors	2 x N-Type jacks
Mounting	Fully adjustable pipe mount (1.63" to 4.5" pipe) with 0-15° down tilt
Dimensions (mm)	711 x 171 x 90
Weight (Kg)	2.6 (excluding mounting kit)
Regulatory Compliance	RoHS Compliance

**1.4.7.3 3.3 -3.8 GHz, 2 Ports 90° Dual Slant (x)****Table 1-10: ANT,BS,3.3-3.8GHz, DS,Sec.90°,15.5dBi min. (P.N. 300645) Specifications**

Item	Description
Frequency Band (MHz)	3300-3800
Number of Elements	2
Polarization	Linear, +/-45°
Gain	15.5dBi +/- 0.5dB
VSWR	1.5:1 (max)
Azimuth Beamwidth (degrees)	85 +/-5
Elevation Beamwidth (degrees)	6 +/-1
Maximum Power (W)	50
Cross-polarization Discrimination (dB)	-17
Front-to-Back Ratio (dB)	>25
Isolation Between Ports (dB)	>25
RF Interface Impedance (Ohm)	50
Lightning Protection	DC grounded
RF Connectors	2 x N-Type jacks
Mounting	Fully adjustable pipe mount (1.63" to 4.5" pipe) with 0-15° down tilt
Dimensions (mm)	711 x 171 x 90
Weight (Kg)	2.6 (excluding mounting kit)
Regulatory Compliance	RoHS Compliance



1.4.7.4 3.3 -3.8 GHz, 4 Ports 65° Double Dual Slant (xx)

Table 1-11: ANT-DDP-65°-3.3-3.8GHz (P.N. 300736) Specifications

Item	Description
Frequency Band (MHz)	3300-3800
Number of Elements	4
Polarization	Linear, 2 x +/-45°
Gain	18dBi
Azimuth Beamwidth (degrees)	65
Elevation Beamwidth (degrees)	7
Maximum Power (W)	150
Cross-polarization Discrimination (dB)	>15
Front-to-Back Ratio (dB)	>30
Isolation Between Ports (dB)	>30
Return Loss (dB)	>15
Upper Sidelobe Suppression (dB)	>18
RF Interface Impedance (Ohm)	50
Lightning Protection	DC grounded
RF Connectors	4 x N-Type jack
Electrical Downtilt	0° (fixed)
Mounting	Adjustable mounting kit (optional) for 50-115mm pole, with +2° to -10° tilt range
Dimensions (mm)	720 x 260 x 55
Weight (Kg)	7 (excluding mounting kit)

**1.4.7.5 3.3 -3.8 GHz, 4 Ports 90° Double Dual Slant (xx)****Table 1-12: ANT-DDP-90°-3.3-3.8GHz (P.N. 300719) Specifications**

Item	Description
Frequency Band (MHz)	3300-3800
Number of Elements	4
Polarization	Linear, 2 x +/-45°
Gain	17dBi
Azimuth Beamwidth (degrees)	90
Elevation Beamwidth (degrees)	7
Maximum Power (W)	150
Cross-polarization Discrimination (dB)	>15
Front-to-Back Ratio (dB)	>30
Isolation Between Ports (dB)	>30
Return Loss (dB)	>15
Upper Sidelobe Suppression (dB)	>18
RF Interface Impedance (Ohm)	50
Lightning Protection	DC grounded
RF Connectors	4 x N-Type jack
Electrical Downtilt	4° (fixed)
Mounting	Adjustable mounting kit (optional) for 50-115mm pole, with +2° to -10° tilt range
Dimensions (mm)	720 x 260 x 55
Weight (Kg)	7 (excluding mounting kit)



1.4.8 BMAX-4M-GPS Receiver Specifications

Table 1-13: BMAX-4M-GPS Receiver, Mechanical & Electrical Specifications

Item	Description
Dimensions	8.8 x 10.4 x 16 cm
Weight	0.38 Kg
Power Source	12 VDC from the BTS
Power Consumption	2W maximum
Connector	RJ-45

Chapter 2 - Commissioning

In This Chapter:

- "Introduction" on page 26
- "Configuring Parameters Required for Management Connectivity" on page 29
- "Activating the Unit" on page 32



2.1 Introduction

After completing the installation process some basic unit's parameters must be configured locally using the Monitor program to enable discovery by the Element Management System and remote management of the unit.

Refer to [“The Monitor Program” on page 38](#) for information on how to access the Monitor program using Telnet and how to use it.

It is recommended to reset the unit to its factory default values before proceeding with following configuration steps: Enter the Monitor program and select BTS>Unit Control>ShutDown Operation>Update>resettoFactoryDefault (you will be prompted to confirm the requested action).



2.2 BreezeCOMPACT Installation

For detailed installation instruction, please refer to BreezeCompact Quick Installation Guide document.



2.3 System Initial Verification

After powerup, the BTS automatically starts a self-testing procedure to verify that the BTS has been correctly assembled and installed on site, all its components are functioning properly, and that it is now ready for commissioning. During the self-test, the LEDs indicate the working status of the various components.



To perform testing:

- 1 Verify that the BTS is connected to an AC power source.
- 2 Upon completion of the internal test and boot up (up to 5 minutes), verify that the following LEDs are lit as follows:

Table 2-1: BreezeCOMPACT LEDs

Name	Description	Functionality
PWR	Power indication	<ul style="list-style-type: none"> ■ Off: There is no 4*V to the internal main power supply module ■ RED: Power is provided to the unit and the internal main power supply module is OK ■ Green: All the internal digital power supply rails are OK
ALRM	Alarm indication	<ul style="list-style-type: none"> ■ Lights at power up ■ Turns off after power up is complete ■ Lights on runtime in case of critical failure
GPS	GPS status indication	<ul style="list-style-type: none"> ■ Lights at power up ■ Turns off after power up is complete ■ Lights when the GPS is reporting at least four satellites or more reception. ■ Blinks (0.5 Sec on, 0.5 Sec off) when the number of satellites decreases from 4 to 3 or 2 satellites or the min. configured value. ■ Turns off when only one satellite is received, or the minimum configured value of GPS is not operational or not installed. ■ Lights again when the unit is regaining satellites reception of 4 satellites or more.

Upon power-up completion, the BTS is ready for basic network definition.



2.4 Configuring Parameters Required for Management Connectivity

The following section describes the minimum mandatory configuration actions required to allow remote management of the site and to enable discovery by the Element Management System:

- [Configuring the BTS Number](#)
- [Configuring the Management Interface Connectivity Mode Parameter](#)
- [Configuring the IP Interfaces Parameters](#)
- [Configuring the L1 and L2 Parameters \(if necessary\)](#)
- [Configuring the SNMP Authorized Manager and Traps Manager](#)
- [Applying the Configuration](#)

2.4.1 Configuring the BTS Number

In the Main menu of the Monitor program, select `BTS>General>Update` and configure the BTS number. The BTS Number must be unique in the Radio Access Network. The default (0) is not a legitimate value.

2.4.2 Configuring the Management Interface Connectivity Mode Parameter

The default Connectivity Mode is inband. If a different Connectivity Mode is required, select `BTS>Connectivity>Management`. You will be prompted to configure the Connectivity Mode.

2.4.3 Configuring the IP Interfaces Parameters

Note that configuration of certain parameters may depend on the value to be configured for the BS Bearer IP Address.

Select `BTS>Connectivity>IP Interfaces>Update`. You will be prompted to configure the following parameters (for some parameters you may just press Enter to keep the default value):

- Bearer Subnet Mask (the default is 255.255.255.0).
- Bearer Next Hop Gateway. Must be within the range defined by BS Bearer IP Address and Bearer Subnet Mask. The default is 0.0.0.0. Must be changed to a valid value if IP addresses of core network equipment is not within the range defined by BS Bearer IP Address and Bearer Subnet Mask.
- Bearer VLAN ID (default 11).
- Default Authenticator IP. The default is 0.0.0.0. Must be changed to a valid value if IP address of default authenticator ASN-GW is not within the range defined by BS Bearer IP Address and Bearer Subnet Mask.



- External Management IP Address. Must be unique in the managed network. The default is 192.168.1.1. Note that in Unified Connectivity Mode the External Management IP Address should be within the addresses range defined by BS Bearer IP Address and Bearer Subnet Mask.
- External Management Subnet Mask. The default is 255.255.255.0. In Unified Connectivity Mode should be configured to the value of the Bearer Subnet Mask.
- External Management Next Hop Gateway. Must be within the range defined by External Management IP Address and External Management Subnet Mask. The default is 0.0.0.0 (must be changed to a valid value if IP address of external management equipment is not within the range defined by External Management IP Address and External Management Subnet Mask). In Unified Connectivity Mode should be configured to the value of the Bearer Next Hop Gateway.
- External Management VLAN ID. The default is 12. In Unified Connectivity Mode should be configured to the value of the Bearer VLAN ID. Otherwise it must differ from the Bearer VLAN ID.
- Local Management IP Address and Local Management Subnet Mask. You may change the Local Management IP Address (the default is 172.31.0.1) and Local Management Subnet Mask (the default is 255.255.255.0). However, it is recommended to always maintain the default value to ensure availability of known IP parameters for local connectivity.

2.4.4 Configuring the L1 and L2 Parameters (if necessary)

The default Port Negotiation Mode of all ports is auto. Typically auto negotiation mode should be used. However, if manual setting of physical interface parameters is required for Data Port 2 or Data Port 3 (If Data Port 1 is Up its Port Negotiation Mode is forced to Full Duplex) :

- Select the applicable port (BTS>Connectivity>L1 & L2>Select>Port Number>2/3). Select the Update option.
- Configure the Port Negotiation Mode parameter to manual.
- Configure the required Port Speed (10/100/100 for Port Number 2, 10/100 for Port Number 3).
- Configure the required Duplex Mode.

2.4.5 Configuring the SNMP Authorized Manager and Traps Manager

2.4.5.1 Configuring the Authorized Manager

By default the unit is supplied with one SNMP Traps Manager with the following parameters:

- Manager Number: 1
- Community Read Only: public
- Community Read and Write: private

If different communities are used by the management system, you should add an SNMP Authorized Manager with the correct communities or update the existing one.



To add an Authorized Manager select `BTS>Management>Authorized Managers>Add`. You will be prompted to configure the Manager Number, the Community Read Only and the Community Read and Write.

To update the default Authorized Manager, select `BTS>Management>Authorized Managers>Select`, at the Manager Number prompt enter 1 and select the Update option. You will be prompted to configure the Community Read Only and the Community Read and Write.

2.4.5.2 Configuring the SNMP Traps Manager

By default the unit is supplied with one SNMP Traps Manager with the following parameters:

- IP Address: 192.168.1.60
- Port Number: 162 (this is the default port number used by the management system)
- Community: public
- Enable Traps Distribution: enable

If different parameters are used by the management system, you should add an SNMP Traps Manager with the correct parameters (the IP Address of an existing SNMP Traps Manager cannot be updated).

To add an SNMP Traps Manager select `BTS>Management>SNMP Traps Managers>Add`. You will be prompted to configure the IP Address, the Port Number, the Community and the Enable Traps Distribution parameter.

2.4.6 Applying the Configuration

To apply the changes, reset the unit (select `BTS>Unit Control>Shutdown operation>Update` and select the reset option).

After the unit reboots, it should be discoverable and manageable from remote by the EMS station.

INFORMATION



Once the unit can be discovered by the management system, the best way to complete the commissioning process is by using offline configuration files pre-prepared using the Mass Configuration Wizard. For more details refer to the Using the Mass Configuration Wizard section in the Management System Infrastructure Manual and to the Using the Offline Tool Wizard section in the Device Driver Manual.

If you do not use pre-prepared offline configuration files, the following section provide details on how to configure additional parameters required for activating the unit using either the management system (after discovering the unit), or the Monitor program.



2.5 Activating the Unit

To activate the unit you must:

- 1 Create the BS
- 2 Define the Antenna(s)
- 3 Configure Radio Cluster parameters
- 4 Define Antenna Associations

After properly completing the above steps the unit will start operating using default values for all other parameters. Additional parameters should be configured according to Radio Network Planning (RNP) guidelines and other instructions provided by the System Administrator.

This section includes:

- [Creating the BS](#)
- [Defining the Antenna\(s\)](#)
- [Configuring Radio Cluster Parameters](#)
- [Configuring Antenna Associations](#)
- [Applying the Configuration](#)

2.5.1 Creating the BS

2.5.1.1 Using the Monitor Program

Select BS>Add. You will be prompted to configure the following mandatory parameters:

- BS Number (must be 1)
- BS ID LSB (must be unique in the Radio Access Network)
- Operator ID
- Cell ID
- Segment Number
- Total Uplink Duration
- Basic Map Repetition
- DL Data Permutation Base
- UL Feedback zone Permutation base
- UL Data Permutation Base
- Bearer IP Address
- Paging Group ID (if other than 0, should be unique in the Radio Access Network)



Refer to [“Add” on page 60](#) for details on these parameters.

2.5.1.2 Using the Management System

1 Right-click the BS node in the navigation tree and select Create to open the New BS window. In the current release only BS Number 1 option is available for BS Number. Configure the following parameters:

- » BS ID LSB (must be unique in the Radio Access Network)
- » Operator ID (the default is 255.243.41. The same Operator ID should be used for all BSs in the Radio Access Network)).

The new BS will be added to the list of BSs available in the BS node.

2 Select the BS and configure the following parameters (for some parameters you may use the default value/option):

■ In Radio>Basic>General:

- » Idle Mode Enable: Mark the check-box to enable Idle Mode. The default is Idle Mode disabled (not checked).
- » Paging Group ID: Applicable only if Idle Mode is enabled. The default is 0 which must be changed. Paging Group ID should be unique in the Radio Access Network.
- » Click Apply.

■ In Radio>Basic>Air Frame Structure General:

- » Cell ID (the default is 0).
- » Segment Number (the default is 0).
- » Total Uplink Duration (the default is 3).
- » Click Apply.

■ In Radio>Basic>Air Frame Structure Zones:

- » First Zone-Basic Map (the default is 6).
- » Downlink Data Zone-Permutation Base (the default is 0).
- » Uplink Feedback Zone-Permutation Base (the default is 0).
- » Uplink Data Zone-Permutation Base (the default is 0).
- » Click Apply.



- In Radio>R6/R8 Bearer Interface>Bearer & Authentication:
 - » Bearer Interface-IP Address.
 - » Click Apply.

2.5.2 Defining the Antenna(s)

2.5.2.1 The Default Antenna

By default, one Antenna object exists, with the following properties:

- Antenna Number: 1
- Antenna Product Type: default4portDS
- Mechanical Down Tilt: 0
- Electrical Down Tilt: 0
- Longitude: 000.000,E
- Latitude: 00.000,N
- Height: 0
- Heading: 0
- Cable Loss: 0.5

According to actually installed antenna(s), you may update any of the existing antenna object parameters (excluding its number) and/or add antenna(s).

2.5.2.2 Using the Monitor Program

To add the Antenna Product Type of actually used antenna(s) using the Monitor program select Antenna>Add. You will be prompted to define all Antenna parameters (including the Antenna Number).

To update the parameters of the default antenna select Antenna>Select. You will be prompted to select the Antenna Number. Enter 1 and select the update option. You will be prompted to configure all parameters.

2.5.2.3 Using the Management System

In the management system, use the Equipment>External>Antenna screen to update the parameters of the default antenna and/or to add antenna(s). Click Apply after completing all configuration changes for each Antenna.

2.5.3 Configuring Radio Cluster Parameters

Using the Monitor Program

Select Sector>Radio Cluster Update and configure the following mandatory parameters:



- Bandwidth
- Center Frequency
- TX Power

Using the Management System

Select Sector 1, in the Radio Cluster section configure the Bandwidth, Center Frequency and TX Power parameters of Radio Cluster 1 and click Apply.

2.5.4 Configuring Antenna Associations

Using the Monitor Program

Select Sector>Antenna Association>Add.

You will be prompted to configure the following parameters:

- RF Port Number: Enter 1.
- Antenna Number: Enter the relevant Antenna Number as configured in the Antenna menu.
- Antenna Port Number: Enter the relevant Antenna Port Number.

Repeat the Antenna Association configuration for RF Port Number 2 to 4.

Using the Management System

In the Association section of Sector 1 screen click Add Association and enter the relevant Antenna Number and Antenna Port Number for RF Port 1.

Repeat the process for RF Port Number 2 to 4.

Click Apply.

2.5.5 Applying the Configuration

To apply the changes, reset the unit:

In the Monitor program, select BTS>Unit Control>ShutDown Operation>Update and select the reset option for the Shutdown Operation parameter.

In the management system, select the Equipment>Chassis screen. In the Shut Down Operation section select the Reset option for the Shut Down Type parameter and click Apply.

Chapter 3 - Operation and Administration

In This Chapter:

- "BTS System Management" on page 37
- "The Monitor Program" on page 38
- "IP Addresses Configuration" on page 41
- "The Main Menu" on page 42
- "BTS Menu" on page 43
- "Sector Menu" on page 58
- "BS Menu" on page 60
- "Chassis Menu" on page 82
- "GPS Menu" on page 84
- "RH Menu" on page 88
- "Antenna Menu" on page 90



3.1 BTS System Management

The BTS can be managed using any of the following options:

- SNMP based management using AlvariSTAR/AlvariCRAFT (or another network management system customized to support management of the system).
- Using Telnet to access the embedded Monitor application.

INFORMATION



Even if supported by network routing, remote management from a station behind an MS (via the wireless link) should be avoided.

This chapter describes how to manage the system using the Monitor application. For information on managing the system using AlvariSTAR/AlvariCRAFT refer to the applicable documentation.

INFORMATION



Generally, it is recommended to use the Monitor program only for initial configuration to enable remote management, and to perform additional configuration and maintenance using AlvariSTAR/AlvariCRAFT.



3.2 The Monitor Program

3.2.1 Accessing the Monitor Program



To access the Monitor program using Telnet:

1 Via the Local Management interface

- a** Direct local management using the Monitor program can be performed via the Local Management interface. The default local management IP Address is 172.31.0.1, and the default Subnet Mask for this address is 255.255.255.0.
- b** The PC used for accessing the Monitor program should be set to IP address 172.31.0.2 or any other address in the range 172.31.0.2 - 172.31.0.254.
- c** Connect the PC to the Ethernet port used for Local Management. In the current release Local Management interface is always on DAT3 port.
- d** Run the Telnet program connecting to IP address 172.31.0.1.
- e** The Enter the password message is displayed. Enter the password and press the Enter key to get to the Main menu. The default password is "installer".

2 Via the External Management interface

- a** Management using either SNMP or the Monitor program can also be performed via the External Management interface. For details on the connectivity parameters of this interface refer to "[IP Interfaces](#)" on page 45.
- b** See "[L1 & L2](#)" on page 47 for details on the Ethernet port used for External Management interface.
- c** Connection of the applicable Ethernet port to the remote management device should typically be performed via a network device configured to support the External Management Interface VLAN ID (the default is 12).
- d** If the PC is connected to the Ethernet port of the unit via a switching device, the IP address of the PC should be set to an address in the subnet of the External Management Interface (the default is IP Address 192.168.1.1 and Subnet Mask 255.255.255.0).
- e** If access is via a routing device, configure the Next Hop Gateway parameter of the External Management Interface (the default is 0.0.0.0 meaning none) to a valid value (in the subnet of the External Management Interface). Set the IP address of the routing device's port connected to the unit to the address of the Next Hop Gateway. Set the IP address of the PC according to the IP configuration of the relevant routing device's port.



To manage the BreezeCOMPACT from an external network, configure the SNMP trap manager to enable auto routing to the remote PC.

- f** Run the Telnet program connecting to the IP address of the External Management interface.
- g** The Enter the password message is displayed. Enter the password and press the Enter key to get to the Main menu. The default password is "installer".

3.2.2 Using the Monitor Program

This section describes the Monitor program structure and navigation rules.

- The header of each menu or submenu specifies the unit type, the management IP address, the running SW version and the name of the menu/submenu including the path from the Main menu.
- Each menu or submenu displays a list of numbered options. To access an option, enter the number of the required option at the > prompt.
- At any point in the program, you can use the **Esc** key to return to the previous menu (one level up) without applying any change.
- Common action options in menus associated with a single entity object (or a group of parameters associated with a single entity object) are:
 - » **Show** option, enabling to view the current configuration of the applicable parameters. For some objects some additional status information is displayed.
 - » **Update** option, enabling to update the configuration of one or more parameters:
 - ◇ Single parameter configuration: displaying a list of numbered parameters. To configure a parameter, enter the number of the required parameter at the > prompt. The availability and/or value range of certain parameters may change according to the value selected for a previous parameter belonging to the same or another group. The current value is displayed for each parameter. To keep the current value - press Enter. To change it - enter a new value and press Enter.
 - ◇ Transaction mode configuration: You will be prompted to configure all parameters one by one. The current value is displayed for each parameter. To keep the current value - press Enter. To change it - enter a new value and press Enter. The new configuration will take effect only after completing the entire configuration process for the relevant entity/group of parameters.



- Common action options in menus associated with multiple entities objects are:
 - » **Show All** option, enabling to view main details of all existing entities.
 - » **Add** option, allowing to add a new entity. You will be prompted to configure all mandatory parameters one by one. The new configuration will take effect only after completing the entire configuration process for the relevant entity.
 - » **Select** option, enabling to select a specific entity (typically by its' number). Common action options for a selected entity (or for logic parameters group of a selected entity) are:
 - ◇ **Show** option, enabling to view the current configuration of the applicable parameters. For some objects some additional status information is displayed.
 - ◇ **Update** option, allowing to update one or more parameters of the entity/group of parameters. You will be prompted to configure all parameters one by one (transaction mode configuration). The current value is displayed for each parameter. To keep the current value - press Enter. To change it - enter a new value and press Enter. The new configuration will take effect only after completing the entire configuration process for the relevant entity/group of parameters.
 - ◇ **Delete** option, enabling deletion of the specific entity from the database.
- Press the **Tab** key for context sensitive help text (where applicable).
- If an erroneous value was entered - the reason of the error or help text will be displayed, and the parameter entry text will be displayed again.
- If the Monitor program is not used for the period of time defined by the Monitor Inactivity Time-out (see "[Monitor Inactivity Timeout](#)" on page 50), the session will be terminated automatically.
- Select the Exit option in the Main menu to exit the program and terminate the session.



3.3 IP Addresses Configuration

3.3.1 IP Address Configuration Restrictions

1 The following IP addresses should not be used and will be rejected:

- 0.0.0.0
- 224.0.0.0 - 255.255.255.255 (Multicasts, RFC 3171 D, RFC 1700 E)

3.3.2 IP Subnets

In a binary representation (32 bits) a Subnet Mask string must comprise a series of contiguous binary '1's starting from the MSB, followed by a series of contiguous binary '0's.

Subnet Masks 0.0.0.0 (all zeros, meaning "nothing") and 255.255.255.255 (all ones, meaning "this address only") are illegal and will be rejected.



3.4 The Main Menu

The Main menu of the Monitor program includes the following options:

- 1 - BTS (see ["BTS Menu" on page 43](#))
- 2 - Sector (see ["Sector Menu" on page 58](#))
- 3 - BS (see ["BS Menu" on page 60](#))
- 4 - Chassis (see ["Chassis Menu" on page 82](#))
- 5 - GPS (see ["GPS Menu" on page 84](#))
- 6 - RH (see ["RH Menu" on page 88](#))
- 7 - Antenna (see ["Antenna Menu" on page 90](#))
- X - Exit (select to exit the Monitor program and terminate the Telnet session)



3.5 BTS Menu

The BTS menu includes the following options:

- [General](#)
- [Connectivity](#)
- [Unit Control](#)
- [Management](#)

3.5.1 General

The BTS General submenu enables viewing the current values and updating the general BTS parameters. The BTS General parameters are:

- [BTS Number](#)
- [BTS Name](#)
- [BTS Address](#)
- [Contact Person](#)
- [Legacy ASN-GW Mode](#)

3.5.1.1 BTS Number

A BTS identifier for management purposes. Must be unique in the entire Radio Access Network.

The range is from 1 to 999999.

The default is 0. A different number (unique in the Radio Access Network) must be configured to support proper management by the management system.

A change in BTS Number will take effect after next reset.

3.5.1.2 BTS Name

An optional descriptive parameter. A string of up to 32 printable characters.

The default is null (an empty string).

3.5.1.3 BTS Address

An optional descriptive parameter. A string of up to 70 printable characters.

The default is null (an empty string).

3.5.1.4 Contact Person

An optional descriptive parameter. A string of up to 32 printable characters.

The default is null (an empty string).



3.5.1.5 Legacy ASN-GW Mode

The Legacy ASN-GW Mode defines functionality supported by the external ASN-GW:

Select enable if using a Cisco ASN GW (supports only IP CS services). BS should support only IPv4 CS-type. It means BS should verify whether this type is received from CPE within the registration request and if so include it in the attachment request towards the ASN-GW. All other CS types supported by CPE and received in registration request will be ignored and not forwarded to the ASN-GW.

Select disable if using any other approved ASN GW. BS should support the following CS-types: IPv4, Ethernet, VLAN, IPv4-over-Ethernet, Pv4-over-VLAN. This means it should verify whether these types are received from CPE within the registration request and if so include them in the attachment request towards the ASN-GW. All other CS types supported by CPE and received in registration request will be ignored and not forwarded to the ASN-GW.

The default is disable.

A change in Legacy ASN-GW Mode will take effect after next reset.

3.5.2 Connectivity

The Connectivity submenu includes the following options:

- [Management Interface](#)
- [IP Interfaces](#)
- [L1 & L2](#)
- [ASN-GW Load Balancing Pools](#)
- [QoS Marking Rules](#)

3.5.2.1 Management Interface

The system uses different IP domains for the following traffic types:

- Bearer IP domain for subscriber data and ASN/CSN control traffic.
- External Management domain for remote management traffic.
- Local Management domain for local (direct) management traffic.

The unit supports the following IP connectivity modes:

- Out Of Band: In the Out Of Band connectivity mode different Ethernet ports are used for bearer traffic and external management traffic.
- In Band: In the In Band connectivity mode the same Ethernet port is used for both bearer traffic and external management traffic. VLANs are used to differentiate between the two traffic types. The bearer VLAN ID is used for the bearer traffic and the external management VLAN ID is used for the external management traffic.



- Unified: In the Unified connectivity mode the bearer traffic and external management traffic are unified. The same Ethernet port is used for both traffic types that share the same VLAN ID.

Refer to [“L1 & L2” on page 47](#) for details on the ports used for each traffic type according to the current Connectivity Mode.

The Management Interface submenu enables viewing the current values and updating the following parameter:

3.5.2.1.1 Connectivity Mode

The connectivity mode to be used by the system (see description above).

The available options are inband, outofband and unified.

The default is inband.

A change in Connectivity Mode will take effect after next reset.

3.5.2.1.2 Actual Connectivity Mode

The Actual Connectivity Mode is applicable only for the Show menu, indicating the current connectivity mode. The Actual Connectivity Mode affects configuration rules for Bearer and External Management parameters.

3.5.2.2 IP Interfaces

The IP Interfaces submenu enables viewing the current values and updating the IP Interfaces' parameters. The IP Interfaces parameters are:

- [Bearer Subnet Mask](#)
- [Bearer Next Hop Gateway](#)
- [Bearer VLAN ID](#)
- [Default Authenticator IP](#)
- [External Management IP Address](#)
- [External Management Subnet Mask](#)
- [External Management Next Hop Gateway](#)
- [External Management VLAN ID](#)
- [Local Management IP Address](#)
- [Local Management Subnet Mask](#)

Note that allowed value range for certain parameters may depend on the value configured (or to be configured) for the BS Bearer IP Address (see [“IP Address” on page 74](#)).

Changes in IP Interfaces parameters will take effect after next reset.

3.5.2.2.1 Bearer Subnet Mask

The subnet mask used with the BS Bearer IP Address.



The default is 255.255.255.0.

A change in Bearer Subnet Mask will take effect after next reset.

3.5.2.2.2 Bearer Next Hop Gateway

The IP Address of the Default Gateway for bearer traffic.

The Bearer Next Hop Gateway must be within the range defined by BS Bearer IP Address and Bearer Subnet Mask.

The default is 0.0.0.0 (must be changed to a valid value if IP addresses of core network equipment is not within the range defined by BS Bearer IP Address and Bearer Subnet Mask).

A change in Bearer Next Hop Gateway will take effect after next reset.

3.5.2.2.3 Bearer VLAN ID

The VLAN ID to be used with bearer traffic.

Valid values are 11-100, 110-4094.

The default is 11.

A change in Bearer VLAN ID will take effect after next reset.

3.5.2.2.4 Default Authenticator IP

The IP Address of the default authenticator ASN-GW.

The default is 0.0.0.0 (must be changed to a valid value).

A change in Default Authenticator will take effect after next reset.

3.5.2.2.5 External Management IP Address

The IP address of the External Management interface. Must be unique in the managed network.

The default is 192.168.1.1.

In Unified Connectivity Mode the External Management IP Address should be within the addresses range defined by BS Bearer IP Address and Bearer Subnet Mask.

A change in External Management IP Address will take effect after next reset.

3.5.2.2.6 External Management Subnet Mask

The Subnet Mask of the External Management interface.

The default is 255.255.255.0.

In Unified Connectivity Mode the External Management Subnet Mask should be configured to the same value as the Bearer Subnet Mask.

A change in External Management IP Address will take effect after next reset.

3.5.2.2.7 External Management Next Hop Gateway

The IP Address of the Default Gateway for external management traffic.



The External Management Next Hop Gateway must be within the range defined by External Management IP Address and External Management Subnet Mask.

The default is 192.168.1.1 (an IP address 0.0.0.0 is a valid value if IP address of external management equipment is within the range defined by External Management IP Address and External Management Subnet Mask).

In Unified Connectivity Mode the External Management Next Hop Gateway should be configured to the same value as the Bearer Next Hop Gateway.

A change in External Management Next Hop Gateway will take effect after next reset.

3.5.2.2.8 External Management VLAN ID

The VLAN ID to be used with external management traffic.

Valid values are 11-100, 110-4094.

The default is 12.

In Unified Connectivity Mode the External Management VLAN ID should be configured to the same value as the Bearer VLAN ID. Otherwise, it must differ from the Bearer VLAN ID.

A change in External Management VLAN ID will take effect after next reset.

3.5.2.2.9 Local Management IP Address

The IP address of the Local Management interface.

The default is 172.31.0.1.

It is recommended to refrain from changing the Local Management IP Address so that it can always be used as the known default address for local management.

A change in Local Management IP Address will take effect after next reset.

3.5.2.2.10 Local Management Subnet Mask

The Subnet Mask of the Local Management interface.

The default is 255.255.255.0.

It is recommended to refrain from changing the Local Management Subnet Mask.

A change in Local Management Subnet Mask will take effect after next reset.

3.5.2.3 L1 & L2

The L1 & L2 option enables viewing or updating the parameters of the following Ethernet ports:

- DAT1 (Data Port 1): An optional 1000 Base-X optical fiber interface. Applicable only if a suitable SFP (Small Form-factor Pluggable) optical interface is installed.
- DAT2 (Data Port 2): A 10/100/1000 Base-T twisted-pair electrical interface.
- DAT3 (Data Port 3): A 10/100 Base-T twisted-pair electrical interface.

Functionality of these ports depends on the Connectivity Mode (see [“IP Interfaces” on page 45](#)):

- Out of Band Connectivity Mode: Data Port 1 or Data Port 2 is used for tagged bearer traffic (see [“Port Negotiation Mode” on page 48](#) for details on selecting the active port when both port are applicable). Data Port 3 is used for tagged external management traffic and for untagged local management traffic.
- In Band Connectivity Mode: Data Port 1 or Data Port 2 is used for both bearer and external management traffic. VLANs are used to separate the two traffic types. Data Port 3 is used for untagged local management traffic.
- Unified Connectivity Mode: Data Port 1 or Data Port 2 is used for both bearer and external management traffic. Both traffic types share the same VLAN. Data Port 3 is used for untagged local management traffic.

If an SFP is installed in DAT1, the selection between Data Port 1 and Data Port 2 will be based on automatic Ethernet activity detection (only one of these ports can be active).

CAUTION

If you want to switch from Data Port 1 to Data Port 2 (or vice versa), the unit must be reset (or powered-down and then powered-up) after physically connecting to the new port.

The L1 & L2 option enables selecting any of the applicable ports for viewing or updating the following parameters:

- [Operational State](#)
- [Port Negotiation Mode](#)
- [Port Speed](#)
- [Duplex Mode](#)
- Actual Duplex Mode: Read-only. The actual duplex mode of the port (none if the port is down)
- Actual Speed: Read-only. The actual speed of the port (0 if the port is down)

3.5.2.3.1 Operational State

The Operational State parameter is applicable only for Show menu, indicating the current operational status of the port (Up or Down).

3.5.2.3.2 Port Negotiation Mode

The mode for negotiating the port speed and the duplex mode with the link partner (Auto or Manual).

The Port Speed and Duplex Mode parameters are configurable only if Port Negotiation Mode is Manual.

The default for all ports is Auto.

For Data Port 1, if the Operational State is Up Negotiation Mode is forced to Auto.

3.5.2.3.3 Port Speed

The port speed to be used for the physical interface.



Applicable only if Port Negotiation Mode is set to Manual.

For Data Port 1 (if applicable) only 1000 Mbps (1 Gigabit) is supported.

For Data Port 2 the valid values are 10, 100 or 1000 Mbps and the default is 1000 Mbps (1 Gigabit).

For Data Port 3 the valid values are 10 or 100 Mbps and the default is 10 Mbps.

3.5.2.3.4 Duplex Mode

The duplex mode for the interface (Full Duplex or Half Duplex).

Applicable only if Port Negotiation Mode is set to Manual.

The default for all ports is Full-Duplex.

For Data Port 1, if the Operational State is Up Duplex Mode is forced to Full Duplex.

3.5.2.4 ASN-GW Load Balancing Pools

The Load Balancing feature provides a WiMAX operator with the capability to build resilient ASN infrastructure using ASN-GW redundancy. Every BS is provisioned with two lists of redundant ASN-GWs (pools). The BS applies round-robin mechanism in order to pick an Authenticator for each MS that performs initial network entry (for more details refer to [“ASN-GW Load Balancing” on page 77](#)). This should eventually distribute the load between Anchor ASN-GWs. Geographical site backup can be achieved by using different priority of ASN-GW pools (Authenticator “metric”).

At the unit (BTS) level, up to two pools (with different priorities), each with up to 10 ASN-GWs, can be defined. Each BS will “inherit” these pools.

The ASN-GW Load Balancing Pools submenu includes two options: Primary Pool and Secondary Pool. Select the Primary or Secondary Pool option to view or update the pool’s content. The options available for each pool are:

- Show: Select this option to view the current content of the pool.
- Add: Select this option to add an ASN-GW address to the pool (up to a maximum of 10 addresses per pool). You will be prompted to define the Index for the entry (a unique number in the range from 1 to 10) before defining the IP Address. An IP Address must be unique per both pools. Broadcast and Multicast addresses are not legal. By default both pools are empty.
- Select: Use this option to select an existing entry in the pool by its Index. You can then view the entry’s IP Address, update the IP Address, or delete the entry.

Note that you should not populate the Secondary Pool if the Primary Pool is empty. Also, you should not delete all entries from the Primary Pool if the Secondary Pool is not empty.

A change in the content of the pools will take effect after next reset.

3.5.2.5 QoS Marking Rules

The QoS Marking Rules option enables viewing or updating the values of 802.1P Priority and/or DSCP marking for outgoing external management traffic.



The QoS Marking Rules parameters are:

- [802.1P Priority](#)
- [DSCP](#)

3.5.2.5.1 802.1P Priority

The 802.1P (VLAN) Priority of management traffic.

The range is 0-7.

The default is 0.

3.5.2.5.2 DSCP

The DSCP value of management traffic.

The range is 0-63.

The default is 0.

3.5.3 Unit Control

The Unit Control menu enables various general control functions such as resetting the BTS, managing the SW versions of the BTS and uploading/downloading configuration backup files.

The Unit Control menu includes the following options:

- [Monitor Inactivity Timeout](#)
- [SW Version Control](#)
- [ShutDown Operation](#)
- [Configuration Files Control](#)
- [TFTP Server](#)

3.5.3.1 Monitor Inactivity Timeout

The Monitor Inactivity Timeout (min.) parameter determines the amount of inactive time following which the unit automatically exits the Monitor program.

The time out duration can range from 0 to 60 minutes. 0 means no inactivity timeout.

The default value is 10 minutes.

3.5.3.2 SW Version Control

The BTS can contain two SW versions:

- **Operational:** Each time the BTS resets it will reboot using the version defined as Operational.
- **Shadow:** Normally the Shadow version is the backup version. Each time a new SW File is downloaded to the BTS, it will be stored as a Shadow version, replacing the previous Shadow Version.

The typical process of upgrading to a new SW version includes the following steps:



- 1 Download the new SW File to the BTS. It will be stored as the Shadow version.
- 2 Reset and run the BTS from its Shadow version. Note that at this stage, if a reset were to occur, the BTS will return to the previous Operational version.
- 3 If you want to continue using the new version, swap the Shadow and Operational versions. The new (currently running) version is now defined as Operational, and will be used each time the BTS reboots. The previous version is defined now as Shadow.

Each SW version includes two identifiers:

- SW File, which is the name of the downloaded SW file. This name does not necessarily include clear identification of the SW version number.
- SW Version, which provides the SW version number.

The SW Version Control menu includes the following options:

- [Show SW Versions](#)
- [Show SW Download Status](#)
- [Load to Shadow](#)
- [Reset and Run from Shadow](#)
- [Set Running Version As Operational](#)

3.5.3.2.1 Show SW Versions

Select this option to view the current available versions and the running version:

- Operational SW File
- Shadow SW File
- Running From: The Source of the current SW (Operational or Shadow)

3.5.3.2.2 Show SW Download Status

Select this option to view the status of the last requested download operation.

3.5.3.2.3 Load to Shadow

The Load to Shadow option enables initiating a process of loading a new SW file to the BTS. The loaded SW file will be stored as the new Shadow file.

The IP address of the TFTP Server holding the SW file to be loaded is defined by the TFTP Server parameter (see [“Configuration Files Control” on page 52](#)). You will be prompted to enter the **File Path And File Name** (up to 50 characters) and to confirm the requested operation.

3.5.3.2.4 Reset and Run from Shadow

Select the Reset and Run from Shadow option to reset the BTS and run the Shadow version after power up. To avoid unintentional actions you will be prompted to confirm the request.



3.5.3.2.5 Set Running Version As Operational

When the BTS is running the Shadow version (after selecting Reset and Run from Shadow), it will boot from the Operational version after the next reset. Select the Set Running Version As Operational option if you want to swap versions so that the running version will become the Operational version and will be the version to be used after reset. To avoid unintentional actions you will be prompted to confirm the request.

3.5.3.3 ShutDown Operation

The ShutDown Operation submenu enables selecting one of the following options:

- **reset**: Select this option to reset the BTS. To avoid unintentional reset, you will be prompted to confirm the reset request. Changes to some of the configurable parameters are applied only after reset.
- **resettoFactoryDefault**: Select this option to restore the factory default configuration of all BTS parameters. All parameters will revert to their default values after the next reset. To avoid unintentional action, you will be prompted to confirm the request.

NOTE!



Reset to default configuration may affect the ability for remote management of the unit.

- **noAction**: Select this option to exit the Shutdown Operation submenu without any action.
- **resettoFactoryDefaultwithConnectivity**: Select this option to restore factory default configuration without changing any of the parameters required for maintaining management connectivity to the unit. To avoid unintentional action, you will be prompted to confirm the request.

The parameters that are maintained without any change include:

- » BTS Number
- » All IP Interfaces parameters
- » All L1 & L2 parameters
- » SNMP Traps Managers configurations
- » Authorized Managers configurations

3.5.3.4 Configuration Files Control

The Configuration Files Control submenu enables viewing the backup configuration files that are currently stored in the unit's configuration backup directory, creating a backup file of the current BTS configuration, managing the optional automatic mechanism for automatically creating backup files on a daily basis, and downloading a configuration file to the BTS from either the internal configuration backup directory or an external TFTP server.



The Files Control menu includes the following menu options:

- [Automatic Configuration Backup](#)
- [Show Configuration Files](#)
- [Create Backup Configuration File](#)
- [Restore From External File](#)
- [Restore From Local File](#)

3.5.3.4.1 Automatic Configuration Backup

A configuration backup file of the device's configuration is created automatically every day. The Automatic Configuration Backup submenu enables viewing and modifying the Daily Backup Time for execution of the automatic backup process.

The format of the Daily Backup Time is HH:MM, where HH is between 0 to 23, MM is between 0 to 59.

The default is 00:00 (midnight)

3.5.3.4.2 Show Configuration Files

Select the Show Configuration Files option to view the Configuration File Name of each of the zipped configuration backup files (up to 3) stored in the unit's configuration backup directory. The file's name includes its creation date and time in the format YYYYMMDDHHMM.xml.gz.

3.5.3.4.3 Create Backup Configuration File

Select the Create Backup Configuration File to view the process status of the last request for creating a configuration backup file or to initiate a manual request for creation of a backup file. The BTS holds the last 3 backup files.

3.5.3.4.4 Restore From External File

The Restore From External File submenu includes the following options:

- **Show:** Select this option to view the details of the last request for restoring a configuration file from an external TFTP server. The displayed details include:
 - » **File Name**
 - » **TFTP Server IP Address**
 - » **Process Status**



- **Update:** Select this option to initiate a new process of restoring a configuration file from an external TFTP server. You will be prompted to define the following parameters:
 - » **File Name:** The path to and file name of the file to be downloaded. A string comprising 1 to 254 characters.
 - » **TFTP Server IP Address:** The IP address of the TFTP Server from which the file should be loaded. The default is 192.168.1.1 (same as the default for External Management IP Address).
 - » **Start Download?:** Select the download File option to initiate the process.

INFORMATION

To avoid loss of connectivity behind a router, the External Management parameters are not changed when loading a Full backup file to the BTS. The values of these parameters configured in the target BTS before the loading process, are maintained.

3.5.3.4.5 Restore From Local File

The Restore From Local File submenu includes the following options:

- **Show:** Select this option to view the details of the last request for restoring a configuration file from the unit's memory. The displayed details include:
 - » **Restore From Local Backup:** noAction or restoretoRAM
 - » **Local File Name**
- **Update:** Select this option to initiate a new process of restoring a local configuration file. You will be prompted to define the following parameters:
 - » **Restore From Local Backup: Select** noAction or restoretoRAM. If you selected restoretoRAM, you will be prompted to select the name of the local file.
 - » **Local File Name:** The name of the local backup file to be restored. A string comprising 1 to 30 characters. Must be the name of one of the existing backup file (see [“Show Configuration Files” on page 53](#)).

3.5.3.5 TFTP Server

The TFTP Server option enables viewing or updating the **TFTP Target IP Address**, which is the IP address of the TFTP server to be used for SW download. Typically the TFTP server is in the same station used for management, and the TFTP Server IP address is identical to the External Management IP Address.

The default TFTP Target IP Address is 192.168.1.1 (same as the default for External Management IP Address).

3.5.4 Management

The Management menu includes the following options:

- [SNMP Traps Managers](#)



- [Authorized Managers](#)

3.5.4.1 SNMP Traps Managers

Up to 5 SNMP Traps Managers can be defined. By default the unit is supplied with one SNMP Traps Manager with the following parameters:

- IP Address: 192.168.1.60
- Port Number: 162
- Community: public
- Enable Traps Distribution: enable

The SNMP Trap Managers menu includes the following options:

- [Show](#)
- [Add](#)
- [Select](#)

3.5.4.1.1 Show

Select this option to view the details of the currently defined SNMP Traps Managers.

3.5.4.1.2 Add

Select this option to add a new SNMP Traps Manager. The SNMP Traps Manager parameters are:

- [IP Address](#)
- [Port Number](#)
- [Community](#)
- [Enable Traps Distribution](#)

3.5.4.1.2.1 IP Address

The IP address of the Traps Manager.

3.5.4.1.2.2 Port Number

The port number on which the Trap Manager will listen for messages from the Agent. The range is from 1 to 65535. The port on which the management system listens for traps is 162.

3.5.4.1.2.3 Community

The name of the SNMP Read Community used by the Trap Manager. Traps are sent toward those Managers for which this parameter is configured. A string of up to 10 printable characters, case-sensitive. The default used by the management system is public.

3.5.4.1.2.4 Enable Traps Distribution

Indicates whether the sending of traps to the management station is enabled or disabled.



3.5.4.1.3 Select

Use this option to select one of the existing SNMP Traps Managers by its IP address. You can then view the details of the selected manager, update its parameters (excluding the IP address) or delete it.

The Selected Manager submenu includes the following options:

- **Show:** For viewing the details of the selected Manager.
- **Update:** For updating the properties of the selected Manager (for details see [Section 3.5.4.1.2](#) above).
- **Delete:** For deleting the selected Manager from the database.

3.5.4.2 Authorized Managers

An SNMP Manager comprises a pair of SNMP Communities (Community Read Only and Community Read and Write). A management station is permitted to manage the BTS using SNMP only if it uses one of the configured SNMP Communities (or a pair of SNMP Communities). A maximum of five SNMP Managers can be configured. The Authorized Managers submenu enables defining the properties of management stations that are allowed to manage the BTS using SNMP.

By default the unit is supplied with one Authorized Manager with the following parameters:

- Manager Number: 1
- Community Read Only: public
- Community Read and Write: private

The Authorized Manager submenu includes the following options:

- [Show](#)
- [Add](#)
- [Select](#)

3.5.4.2.1 Show

Select this option to view the details of all currently defined authorized managers.

3.5.4.2.2 Add

Select this option to add a new authorized manager. Up to 5 Authorized Managers can be defined. The following parameters can be configured:

- [Manager Number](#)
- [Community Read Only](#)
- [Community Read and Write](#)

3.5.4.2.2.1 Manager Number

A unique number from 1 to 5.



3.5.4.2.2.2 Community Read Only

The SNMP Read Community to be used by the Authorized Manager. A null Community Read Only means that the read (get) operation can only be performed using the Community Read and Write.

Valid Community strings: Up to 10 printable characters, case sensitive.

The default is public.

3.5.4.2.2.3 Community Read and Write

The SNMP Read/Write Community to be used by the Authorized Manager. A null Read/Write Community means that the Authorized Manager has Read Only access rights.

Valid Community strings: Up to 10 printable characters, case sensitive.

The default is private.

INFORMATION



To enable management by AlvariSTAR/AlvariCRAFT, the Read and Write Communities are mandatory and both must be defined (other than null).

Duplication of Communities pairs is not allowed (each Read/Write Community pair must be unique).

3.5.4.2.3 Select

This option enables selecting an existing authorized manager for viewing or updating its properties or for deleting it from the database. The selection is based on the authorized manager's number.

The Selected Manager submenu includes the following options:

- **Show:** For viewing the details of the selected Manager.
- **Update:** For updating the properties of the selected Manager (for details see [Section 3.5.4.2.2](#) above).
- **Delete:** For deleting the selected Manager from the database.



3.6 Sector Menu

In the current release the unit supports a single sector.

The Sector menu includes the following options:

- [Sector Definition](#)
- [Radio Cluster](#)
- [Antenna Association](#)

3.6.1 Sector Definition

The Sector Definition menu enables viewing or modifying the following informational parameters:

3.6.1.1 Name

The sector name. An optional descriptive string of up to 32 printable characters.

The default is null (an empty string).

3.6.1.2 Heading

The sector heading (the center angle of the sector), in degrees.

An optional descriptive value in the range from 0 to 359.

The default is 0.

3.6.1.3 Width

The planned sector coverage, in degrees.

A value in the range from 0 to 359.

The default is 0.

3.6.2 Radio Cluster

Radio Cluster is a virtual object enabling definition of the bandwidth, frequency and transmit power parameters. The values configured for these parameter determine the bandwidth and frequency of relevant BS(s) and the Tx power of all relevant Radio Head Tx ports. The Radio Cluster concept simplifies configuration of these parameters, especially in installations using dual-carrier operation (One Sector Dual Carrier topology, not supported in current release).

The Radio Cluster menu enables viewing or modifying the following parameters:

3.6.2.1 Bandwidth

The bandwidth of the Radio Cluster, in MHz.

Available valid options are 5 MHz (fiveMHz), 7 MHz (sevenMHz) and 10 MHz (tenMHz).



The default is none. A valid option must be selected.

A change in Bandwidth will take effect after next reset.

3.6.2.2 Center Frequency

The center downlink frequency of the Radio Cluster, in MHz. The valid values are from $f1+0.5BW$ to $f2-0.5BW$, where $f1$ is the lowest frequency of the band supported by the radio head (see [RH Menu, "General" on page 88](#)), $f2$ is the highest frequency of the band, and BW is the defined Bandwidth.

The default is 0. A valid value must be configured.

A change in Center Frequency will take effect after next reset.

3.6.2.3 TX Power

The required tx power of the Radio Cluster, in dBm.

The actually valid range depends on Installed RH Type: The upper limit is set by the Maximum Tx Power supported by the radio head (see [RH Menu, "General" on page 88](#)). The lower limit is the Maximum Tx Power supported by the radio head minus 10dBm.

The default is 0. A valid value must be configured.

3.6.3 Antenna Association

The Antenna Association menu enables viewing and updating the Antenna And Antenna Port for each antenna association entry. Actual physical connections must match the configured values and the operation mode configured for relevant ports (see ["Ports Control" on page 82](#)).

The selection key for each entry is the RF Port Number(1-4).

A change in Antenna Association will take effect after next reset.

The configurable parameters for each RF Port are:

3.6.3.1 Antenna Number

A number in the range from 1 to 4.

The default is null. The relevant Antenna Number as specified in ["Antenna Menu" on page 90](#) must be configured.

3.6.3.2 Antenna Port Number

A number in the range from 1 to 4.

The default is null. The relevant Antenna Port Number (according to the number of ports supported by the selected antenna) must be configured.

Each port cannot be used more than once (each combination of Antenna Number and Antenna Port Number must be unique).



3.7 BS Menu

In the current release a single BS is supported. The BS menu enables creating the BS, updating the BS parameters or deleting the BS (the BS ID LSB of an existing BS cannot be modified. To change the BS ID LSB, you must delete the BS and re-create it).

INFORMATION



BS parameters should be configured according to the recommendations of the Radio Network Planning

The BS menu includes three options:

- **Add:** For creating a new BS.
- **Select:** For updating the parameters of a previously created BS or deleting the BS.
- **Show:** For viewing main BS parameters.

3.7.1 Add

Select the Add option to create the BS. If the BS does not exist already, it must be created. In the current release only a single BS can be defined. If a BS already exist, you cannot add another BS.

After completing configuration of all BS mandatory parameters, reset the unit to apply the change.

You will be prompted to configure the following BS parameters:

3.7.1.1 BS Number

In the current release only BS Number 1 can be created.

3.7.1.2 BS ID LSB

The unique identifier of the BS in the network. Must be unique in the entire Radio Access Network. A number in the range 1-16777215. The BS ID LSB used in the system is in the format A.B.C where A, B, C are from 0 to 255. The BS ID used in the Monitor program is an integer that is calculated by the formula $A*65536+B*256+C$. For example, a BS ID of 1.2.5 is translated to $1*65536+2*256+5=66053$.

3.7.1.3 Operator ID

The unique identifier of the wireless network operator. The same Operator ID must be used by all BSs in the managed wireless network. A number in the range 1-16777215 (same definition principle as for BS ID LSB).

3.7.1.4 Name

An optional descriptive parameter. A string of up to 32 characters. The default is null.



3.7.1.5 Cell ID

The Cell ID (IDCell) used for preamble selection. The range is from 0 to 31.

3.7.1.6 Segment Number

The segment (BS) number in a three sector BS (0-2).

3.7.1.7 Total Uplink Duration

The total duration of the uplink in a frame, in slots (one slot equals 3 symbols).

To avoid BS-BS interference, the Total Uplink Duration must be identical in all BSs in the same geographical region.

The range is 4-7 for a BS bandwidth of 5 or 10MHz, 3-5 for a BS bandwidth of 7MHz.

3.7.1.8 Basic Map Repetition

The basic repetition used in the transmission of the maps using QPSK 1/2. The available options are 1, 2, 4 and 6. (1 means no repetitions)..

If BS BW=5MHz only values 1, 2, and 4 should be used.

3.7.1.9 DL Data Permutation Base

The permutation base used in the downlink data zone.

The valid range is from 0 to 31 for 7/10MHz channels, 0 to 17 for 5MHz Channel.

3.7.1.10 UL Feedback Zone Permutation Base

The permutation base used in the uplink feedback zone.

The valid range is from 0 to 69 for 7/10MHz channels and 0-17 On 5MHz channels

3.7.1.11 UL Data Permutation Base

The permutation base used in the uplink data zone, The valid range is from 0 to 69

3.7.1.12 IP Address

The IP address of the bearer interface of the BS. Must be unique in the network.

3.7.1.13 Paging Group ID

The Paging Group ID of the BS.

The range is from 0 to 65535. 0 means that Idle Mode is not enabled. If Idle Mode is enabled (Paging Group ID is not 0), should be unique in the Radio Access Network (different Paging Group ID for each BS). Idle Mode should be either enabled in all units in the network (Paging Group ID other than 0) or disabled in all units (Paging Group ID = 0). A combination in the same Radio Access Network of units



with Paging Group ID of 0 (Idle Mode disabled) and units with Paging Group ID other than 0 (Idle Mode enabled) should be avoided.

3.7.2 Select

Select the BS to view or update its parameters or to delete it. BS is selected by its BS Number.

The selected BS menu includes the following options:

- General
- Air Frame Structure
- Mobility
- Power Control
- Feedback
- Connectivity
- Connectivity
- Management Thresholds
- Keep Alive
- Scheduler

3.7.2.1 General

The selected BS General parameters menu includes the following options:

- Show: Select to view the current values of the BS General parameters.
- Update: Select to update the configured values of the BS General parameters.
- Delete: Select to delete the BS (the BS ID LSB of an existing BS cannot be modified. To change it you must delete the BS and re-define it).

The BS General parameters are:

- BS ID LSB
- Operator ID
- Name
- Calculated Center Frequency
- Calculated Bandwidth
- Paging Group ID

3.7.2.1.1 BS ID LSB

Available only in Show menu (the BS ID LSB of an existing BS cannot be modified). The unique identifier of the BS in the network. Can be configured only during BS creation (see [Section 3.7.1.2](#)).



3.7.2.1.2 Operator ID

The unique identifier of the wireless network operator. The same Operator ID must be used by all BSs in the managed wireless network. A number in the range 1-16777215. The Operator ID used in the system is in the format A.B.C where A, B, C are from 0 to 255. The Operator used in the Monitor program is an integer that is calculated by the formula $A*65536+B*256+C$. For example, an Operator ID of 1.1.1 is translated to $1*65536+1*256+1=65793$.

A change in Operator ID will take effect after next reset.

3.7.2.1.3 Name

The name of the BS. An optional descriptive parameter. A string of up to 32 printable characters.

3.7.2.1.4 Calculated Center Frequency

Available only in Show menu. The center of the frequency band in which the BS will transmit, in MHz. Calculated according to the Center Frequency configured for the Radio Cluster and the Topology Type. In the current release (supporting only One Sector One Carrier topology) the BS Calculated Center Frequency equals the Radio Cluster's Center Frequency.

3.7.2.1.5 Calculated Bandwidth

Available only in Show menu. The BS channel bandwidth (5 MHz, 7 MHz, 10MHz).

Calculated according to the Bandwidth configured for the Radio Cluster and the Topology Type. In the current release (supporting only One Sector One Carrier topology) the BS Calculated Bandwidth equals the Radio Cluster's Bandwidth.

3.7.2.1.6 Paging Group ID

The Paging Group ID of the BS.

The single sector Idle Mode capability provides the benefits of MS power savings and manageable total sector active and non active users, together with reduced overhead on the backhaul network.

Idle Mode (IM) mechanism allows an MS to become unavailable on the air interface, and thus freeing operational resources and preserving MS power. During IM operation, an MS switch off its transmission and reception capabilities, and becomes available for DL broadcast control messaging, i.e., MS Paging, in a periodically manner. Using paging broadcast, BS can indicate (if necessary) the MS to exit from IM and return into normal operation mode. The paging control message is sent over the DL of a set of BSs simultaneously. This set is called Paging group (PG). In the current release, each Paging Group includes a single BS.

During IM, MS performs location updates when moving from one PG to another. While in the same PG, MS does not need to transmit in the UL and can be paged in the DL if there is traffic targeted at it.

The range is from 0 to 65535. 0 means that Idle Mode is not enabled. If Idle Mode is enabled (Paging Group ID is not 0), should be unique in the Radio Access Network (different Paging Group ID for each BS). Idle Mode should be either enabled in all units in the network (Paging Group ID other than 0) or disabled in all units (Paging Group ID = 0). A combination in the same Radio Access Network of units with Paging Group ID of 0 (Idle Mode disabled) and units with Paging Group ID other than 0 (Idle Mode enabled) should be avoided.



A change in Paging Group ID will take effect after next reset.

3.7.2.2 Air Frame Structure

The Air Frame Structure menu includes the following options:

- [Zones](#)
- [General](#)
- [DL Diversity Mode](#)

3.7.2.2.1 Zones

The Air Frame Structure - Zones menu includes the following options:

- [Uplink Data Zone](#)
- [Downlink Data Zone](#)
- [First Zone](#)
- [Uplink Feedback Zone](#)
- [Frame Structure Mode](#)

3.7.2.2.1.1 Uplink Data Zone

The Uplink Data Zone menu enables viewing/updating the values configured for the following parameters:

- [Uplink Basic Rate](#)
- [UL Permutation Base](#)

3.7.2.2.1.1.1 Uplink Basic Rate

The uplink basic rate:

- [ctcQpskOneOverTwoTimesSix](#) (QPSK 1/2 Repetition 6)
- [ctcQpskOneOverTwoTimesFour](#) (QPSK 1/2 Repetition 4)
- [ctcQpskOneOverTwoTimesTwo](#) (QPSK 1/2 Repetition 2)
- [ctcQpskOneOverTwo](#) (QPSK 1/2)
- [ctcQpskThreeOverFour](#) (QPSK 3/4)
- [ctcQamSixteenOneOverTwo](#) 16-QAM 1/2
- [ctcQamSixteenThreeOverFour](#) (16-QAM 3/4)
- [ctcQamSixtyFourOneOverTwo](#) (64-QAM 1/2)
- [ctcQamSixtyFourTwoOverThree](#) (64-QAM 2/3)
- [ctcQamSixtyFourThreeOverFour](#) (64-QAM 3/4)
- [ctcQamSixtyFourFiveOverSix](#) 64-QAM 5/6



The default is `ctcQpskOneOverTwo` (QPSK 1/2).

A change in Uplink Basic Rate will take effect after next reset.

3.7.2.2.1.1.2 UL Permutation Base

The permutation base used in the uplink data zone.

The valid range is from 0 to 69.

A change in UL Permutation Base will take effect after next reset.

3.7.2.2.1.2 Downlink Data Zone

The Downlink Data Zone menu enables viewing/updating the values configured for the following parameters:

- [Basic Rate for Management](#)
- [Basic Rate for Data](#)
- [DL Data Permutation Base](#)

3.7.2.2.1.2.1 Basic Rate for Management

The downlink basic rate for unicast and broadcast management traffic (non-HARQ traffic in reuse 1 region):

- `ctcQpskOneOverTwoTimesSix` (QPSK 1/2 Repetition 6)
- `ctcQpskOneOverTwoTimesFour` (QPSK 1/2 Repetition 4)
- `ctcQpskOneOverTwoTimesTwo` (QPSK 1/2 Repetition 2)
- `ctcQpskOneOverTwo` (QPSK 1/2)
- `ctcQpskThreeOverFour` (QPSK 3/4)
- `ctcQamSixteenOneOverTwo` 16-QAM 1/2
- `ctcQamSixteenThreeOverFour` (16-QAM 3/4)
- `ctcQamSixtyFourOneOverTwo` (64-QAM 1/2)
- `ctcQamSixtyFourTwoOverThree` (64-QAM 2/3)
- `ctcQamSixtyFourThreeOverFour` (64-QAM 3/4)
- `ctcQamSixtyFourFiveOverSix` 64-QAM 5/6

The default is `ctcQpskOneOverTwo` (QPSK 1/2).

A change in Basic Rate for Management will take effect after next reset.

3.7.2.2.1.2.2 Basic Rate for Data

The downlink basic rate for HARQ data traffic in reuse 1 region:

- `ctcQpskOneOverTwoTimesSix` (QPSK 1/2 Repetition 6)
- `ctcQpskOneOverTwoTimesFour` (QPSK 1/2 Repetition 4)



- ctcQpskOneOverTwoTimesTwo (QPSK 1/2 Repetition 2)
- ctcQpskOneOverTwo (QPSK 1/2)
- ctcQpskThreeOverFour (QPSK 3/4)
- ctcQamSixteenOneOverTwo 16-QAM 1/2
- ctcQamSixteenThreeOverFour (16-QAM 3/4)
- ctcQamSixtyFourOneOverTwo (64-QAM 1/2)
- ctcQamSixtyFourTwoOverThree (64-QAM 2/3)
- ctcQamSixtyFourThreeOverFour (64-QAM 3/4)
- ctcQamSixtyFourFiveOverSix 64-QAM 5/6

The default is ctcQpskOneOverTwo (QPSK 1/2).

A change in Basic Rate for Data will take effect after next reset.

3.7.2.2.1.2.3 DL Data Permutation Base

The permutation base used in the downlink data zone.

The valid range is from 0 to 31.

A change in DL Data Permutation Base will take effect after next reset.

3.7.2.2.1.3 First Zone

The First Zone menu enables viewing/updating the values configured for the following parameters:

- [Basic Map Repetition](#)
- [Minimum Size](#)
- [Maximum Size](#)
- [Maximum Map Size](#)

3.7.2.2.1.3.1 Basic Map Repetition

The basic repetition used in the transmission of the maps using QPSK 1/2. The available options are 1, 2, 4 and 6. (1 means no repetitions).

If BS BW=5MHz only values 1, 2, and 4 should be used.

The default is 6 (rate QPSK 1/2 repetition 6).

A change in Basic Map Repetition will take effect after next reset.

3.7.2.2.1.3.2 Minimum Size

The initial size (in symbols) of the first zone.

The available options are 2, 4, ..., 34 (2xN where N=1-17) or -1 for No Limitation. The default is -1 (No Limitation), meaning that the actual size will be set dynamically according to the configuration.

See limitations in [First Zone Minimum Size Recommended Value Range](#) table below. Other values should be avoided.



The default (no limitation) means that the actual size will be set dynamically according to the configuration.

A change in Minimum Size will take effect after next reset.

3.7.2.2.1.3.3 Maximum Size

Maximum size (in symbols) for first zone. Used mainly for performance control capability within frame.

The available options are 2, 4, ..., 34 ($2 \times N$ where $N=1-17$) or -1 for No Limitation. The default is -1 (No Limitation).

Maximum Size cannot be lower than Minimum Size.

A change in Maximum Size will take effect after next reset.

Recommended values for First Zone Minimum Size and Maximum Size:

Table 3-1: First Zone Minimum Size Recommended Value Range

BS Bandwidth (MHz)	Basic Map Repetition	Minimum Size (symbols) (up to a maximum of Y as defined below)
7/10	6	No Limitation or $8+2N$
	4	No Limitation or $6+2N$
	2	No Limitation or $4+2N$
	1	No Limitation or $4+2N$
5 MHz	6	N/A
	4	No Limitation or $8+2N$
	2	No Limitation or $6+2N$
	1	No Limitation or $4+2N$

For First Zone Maximum Size the values are:

- If First Zone Minimum Size is set to No Limitations, the value range for Maximum Size is the same as for Minimum Size.
- Else, the value range is No Limitations or First Zone Minimum Size+ $2N$, up to a maximum of Y as defined below.

The value of Y (which is actually the number of slots available for DL data) that sets the upper limit for the Minimum and Maximum Size parameters depends on the Maximum Cell Radius and Total Uplink Duration parameters, using the following formula:

$$Y = A - 3 * (\text{Total Uplink Duration}) - (\text{Extra TTG}),$$

where $A=46$ for BW of 5 or 10 MHz, and 32 for BW of 7 MHz.

**Table 3-2: Calculating the Upper Limit Value (Y) for Minimum and Maximum Size**

BS Bandwidth (MHz)	Maximum Cell Radius	Total Uplink Duration (slots)	Extra TTG (symbols)	Upper Limit (Y)
5/10	1, 2, 4, 8	4	0	34
		6	0	28
	1, 2, 4, 8, 15, 23	5	1	30
		7	1	24
	15, 23, 30	4	2	32
		6	2	26
	30	5	3	28
		7	3	22
7	1, 2, 4, 8, 15, 23	4	0	20
	1, 2, 4, 8, 15, 23, 30	3	1	22
		5	1	16
	30	4	2	18

3.7.2.2.1.3.4 Maximum Map Size

Limits the maximum size of maps (in slots).

The available options are 10, 20...300 (10xN where N=1-30) or -1 for No Limitation. The default is -1 (No Limitation).

A change in Maximum Map Size will take effect after next reset.

3.7.2.2.1.4 Uplink Feedback Zone

The Uplink Feedback Zone menu enables viewing/updating the values configured for the following parameter:

3.7.2.2.1.4.1 Uplink Feedback Zone Permutation Base

The permutation base used in the uplink feedback zone.

The valid range is from 0 to 69.

A change in Uplink Feedback Zone Permutation Base will take effect after next reset.

3.7.2.2.1.5 Frame Structure Mode

The Frame Structure Mode menu enables viewing/updating the values configured for the following parameter:



3.7.2.2.1.5.1 FFR Mode

- The currently supported Fractional Frequency Reuse (FFR) option is None: All downlink and uplink transmissions are with reuse 1 (full load):
 - » First downlink zone includes FCH and maps transmitted using reuse 1 (full load PUSC). May include also broadcasts.
 - » Second downlink zone includes HARQ and Non-HARQ data traffic transmitted using reuse 1 (full load PUSC). May include management messages.
 - » The uplink subframe includes a single zone transmitted using reuse 1 (full load PUSC).

3.7.2.2.2 General

The Air Frame Structure - General Tmenu enables viewing/updating the values configured for the following parameters:

- Cell ID
- Preamble Group
- Segment Number
- Preamble Index
- Total Uplink Duration
- Operational Status Channel 1
- Operational Status Channel 2
- Operational Status Channel 3
- Operational Status Channel 4

3.7.2.2.2.1 Cell ID

The Cell ID (IDCell) used for preamble selection. The range is from 0 to 31.

A change in Cell ID will take effect after next reset.

3.7.2.2.2.2 Preamble Group

The preamble group (1 or 2). A value of 2 is applicable only for the following combinations of Segment Number and Cell ID values:

Segment Number=0, Cell ID=0, 3, 6, 9, 12, 15.

Segment Number=1, Cell ID=1, 4, 7, 10, 13, 16.

Segment Number=2, Cell ID=2, 5, 8, 11, 14, 17

The default is 1.

A change in Preamble Group will take effect after next reset.

3.7.2.2.2.3 Segment Number

The segment (BS) number in a three sector BS (0-2).



A change in Segment Number will take effect after next reset.

3.7.2.2.2.4 Preamble Index

Read-only. The Preamble Index used by the BS (0-113).

3.7.2.2.2.5 Frame Number Offset

Controls the offset applied between the internal frame count and the reported frame number. The available options are Zero and Random. If Random is selected, the device will choose a random number between 0 to 15. The default is zero (0).

A change in Frame Number Offset will take effect after next reset.

3.7.2.2.2.6 Total Uplink Duration

The total duration of the uplink in a frame, in slots (one slot equals 3 symbols).

To avoid BS-BS interference, the Total Uplink Duration must be identical in all BSs in a geographical region.

The range is 4-7 for a BS bandwidth of 5 or 10MHz, 3-5 for a BS bandwidth of 7MHz.

A change in Total Uplink Duration will take effect after next reset.

The table below provides details on DL:UL ratio as a function of BS Bandwidth and Total Uplink Duration.

Table 3-3: DL:UL Ratios

BS Bandwidth (MHz)	Total Uplink Duration (slots)	DL:UL Ratio
5/10	4	35:12
	5	32:15
	6	29:18
7 MHz	3	24:9
	4	21:12

3.7.2.2.2.7 Operational Status Channel 1

Read-only. The operational status of Channel 1.

3.7.2.2.2.8 Operational Status Channel 2

Read-only. The operational status of Channel 2.

3.7.2.2.2.9 Operational Status Channel 3

Read-only. The operational status of Channel 3.

3.7.2.2.2.10 Operational Status Channel 4

Read-only. The operational status of Channel 4.

3.7.2.2.3 DL Diversity Mode

The DL Diversity Mode option includes the DL Diversity Mode parameter. In the current release only Matrix A or B is supported.



In MIMO Matrix A or B mode the system can use either MIMO Matrix A or MIMO Matrix B. The selection between Matrix A and Matrix B is performed automatically for each MS according to link conditions and supported MS capabilities.

- **MIMO Matrix A for Coverage Gain:** In configuration with multiple transmit/receive antennas, a single data stream is transmitted in parallel over multiple paths. A mathematical algorithm known as Space Time Codes (STC) is used to encode the data streams to make them orthogonal to each other. This improves the signal to noise ratio at the receiver side, resulting in increased range and better throughput for subscribers that are difficult to reach (e.g. deep indoors).
- **MIMO Matrix B for Increased Capacity:** This flavor of MIMO, also known as Spatial Multiplexing MIMO (SM-MIMO), sends an independent data stream over each antenna. Thus, in case signal conditions are good, the data rate is increased and in excellent conditions may be doubled.

3.7.2.3 Mobility

The Mobility menu enables viewing/updating the value configured for the following parameter:

3.7.2.3.1 Deployment

The type of deployment in the area served by the BS: Fix or Mobile. To support proper handover, should be set to Fix only if mobile MSs are not expected. The default is Fix.

A change in the Deployment parameter will take effect after next reset.

3.7.2.4 Power Control

The Power Control menu enables viewing/updating the values configured for the following parameters:

- [Target Ni](#)
- [Allowed Interference Level](#)

3.7.2.4.1 Target Ni

The target noise and interference level for the PUSC zone, in dBm.

The range is from -130 to -110 in steps of 1 (dBm). The default is -127.

3.7.2.4.2 BS Transmit Power

Available only in Show menu. The Transmit Power of transmissions from the BS. Calculated according to the TX Power configured for the Radio Cluster and the Topology Type. In the current release (supporting only One Sector One Carrier topology) the BS Transmit Power is the same as the Radio Cluster's TX Power.

3.7.2.4.3 Allowed Interference Level

This parameter defines the correction of maximum allowed UL SINR based on measured DL SINR.

The options are Very High, High, Medium, Low.

The default is High.

A change in Allowed Interference Level will take effect after next reset.



3.7.2.5 Feedback

The Feedback menu enables viewing/updating the values configured for the following parameters:

- [IR CDMA Allocations Period](#)
- [Start of Ranging Codes Used](#)
- [Maximum Cell Radius](#)
- [Ducting Mitigation Mode](#)

3.7.2.5.1 IR CDMA Allocations Period

The period of IR CDMA allocations (Initial Ranging Interval), in frames.

The available options are 1, 2, 4, 6, 8, 10. The default is 2.

A change in IR CDMA Allocations Period will take effect after next reset.

3.7.2.5.2 Start of Ranging Codes Used

The starting number of the group of codes used for the uplink.

The available options are 0, 64, 128, 192. The default is 0.

A change in Start of Ranging Codes Used will take effect after next reset.

3.7.2.5.3 Maximum Cell Radius

The maximum cell radius (in km).

The available values are 1, 2, 4, 8, 15, 23, 30. The default is 2.

A change in Maximum Cell Radius will take effect after next reset.

3.7.2.5.4 Ducting Mitigation Mode

Sudden changes in the atmosphere's moisture and temperature profiles can on random occasions make radio signals propagate hundreds of kilometers and even more, far beyond the normal radio-horizon. When a BS suffers from such tropospheric ducting phenomena causing reception of a relatively strong signal transmitted by a very far BTS, the Ducting Mitigation feature enables increasing the time period between DL and UL transmissions to reduce potential interference effects. This is achieved by adding DL Silenced Symbols and, if necessary, changing the number of Extra TTG slots (see below). This results in reducing the actual UL Duration by 1 slot (Medium Ducting Mitigation Mode) or 2 slots (High Ducting Mitigation Mode) without affecting the number of DL symbols (for the same combination of Configured Total Uplink Duration and Maximum Cell Radius).

Note that for certain values of configured Total Uplink Duration the High and/or Medium options are not available since the minimum uplink duration is 4 slots for a BS bandwidth of 5/10 MHz or 3 slots for a BS bandwidth of 7 MHz.

The options are None, Medium or High.

The default is None.

Table 3-4: Functionality of Allowed Ducting Mitigation Modes, 5/10 MHz BS Bandwidth

Configured Total Uplink Duration (slots)	Mitigation Mode	Maximum Cell Radius (Km)	Extra TTG (symbols)	Added DL Silenced Symbols	Actual Uplink Duration (slots)	DL Symbols
4	None	1, 2, 4, 8	0	0	5	34
		15, 23, 30	2	0	4	32
	Medium	N/A				
	High	N/A				
5	None	1, 2, 4, 8, 15, 23	1	0	5	30
		30	3	0	5	28
	Medium	1, 2, 4, 8	0	4	4	30
		15, 23	2	2	4	30
		30	2	4	4	28
	High	N/A				
6	None	1, 2, 4, 8	0	0	6	28
		15, 23, 30	2	0	6	26
	Medium	1, 2, 4, 8	1	2	5	28
		15, 23	1	4	5	26
		30	3	2	5	26
	High	1, 2, 4, 8	0	6	4	28
15, 23, 30		2	6	4	26	
7	None	1, 2, 4, 8, 15, 23	1	0	7	24
		30	3	0	7	22
	Medium	1, 2, 4, 8	0	4	6	24
		15, 23	2	2	6	24
		30	2	4	6	22
	High	1, 2, 4, 8, 15, 23	1	6	5	24
30		3	9	5	22	

Table 3-5: Functionality of Allowed Ducting Mitigation Modes, 7 MHz BS Bandwidth

Configured Total Uplink Duration (slots)	Mitigation Mode	Maximum Cell Radius (Km)	Extra TTG (symbols)	Added DL Silenced Symbols	Actual Uplink Duration (slots)	DL Symbols
3	None	1, 2, 4, 8, 15, 23, 30	1	0	3	22
	Medium	N/A				
	High	N/A				
4	None	1, 2, 4, 8, 15, 23	0	0	4	20
		30	2	0	4	18
	Medium	1, 2, 4, 8, 15, 23	1	2	3	20
		30	1	4	3	18
	High	N/A				
5	None	1, 2, 4, 8, 15, 23, 30	1	0	5	16
	Medium	1, 2, 4, 8, 15, 23	0	4	4	16
		30	2	2	4	16
	Long	1, 2, 4, 8, 15, 23, 30	1	6	3	16

3.7.2.6 Connectivity

The Connectivity menu includes the following options:

- [Bearer Interface](#)
- [Authentication](#)
- [QOS Marking Rules](#)
- [ASN-GW Load Balancing](#)

3.7.2.6.1 Bearer Interface

The Bearer Interface menu enables viewing/updating the values configured for the following parameters:

- [IP Address](#)
- [Default Gateway Connectivity Status](#)

3.7.2.6.1.1 IP Address

The IP address of the bearer interface of the BS. Must be unique in the network.

A change in Bearer IP Address will take effect after next reset.



3.7.2.6.1.2 Default Gateway Connectivity Status

Read-only. The status of connectivity with the default authenticator: unknown, up, down. The keep-alive mechanism starts only after first registration at the ASN-GW. Until then this mechanism is disabled and connectivity status is unknown.

3.7.2.6.2 Authentication

The Authentication menu enables viewing/updating the values configured for the following parameter:

3.7.2.6.2.1 Threshold - Active MSs

The threshold for the number of MSs in active operation state (not Idle) served by the BS. Exceeding this threshold sets the alarm "Excessive MS number".

The range is 0-512. When set to 0, the alarm is disabled. The default is 512.

3.7.2.6.3 QoS Marking Rules

The QoS Marking Rules menu includes the following options:

- [Internal ASN Traffic QoS Rules](#)
- [Internal Management Traffic QoS Rules](#)
- [QoS Rules](#)

3.7.2.6.3.1 Internal ASN Traffic QoS Rules

The Internal ASN Traffic QoS Rules menu enables viewing/updating the values configured for the following parameters:

- [Intra ASN DSCP](#)
- [802.1p Priority](#)

3.7.2.6.3.1.1 Intra ASN DSCP

DSCP priority value to be used for marking of intra-ASN (R8/R6) traffic. The range is 0-63. The default is 0.

A change in Diffserve Code Point will take effect after next reset.

3.7.2.6.3.1.2 802.1p Priority

802.1p priority value to be used for marking of intra-ASN (R8/R6) traffic. The range is 0-7. The default is 0.

A change in 802.1p Priority will take effect after next reset.

3.7.2.6.3.2 Internal Management Traffic QoS Rules

The Internal Management Traffic QoS Rules menu enables viewing/updating the values configured for the following parameters:

- [Diffserv Code Point](#)
- [802.1p Priority](#)



3.7.2.6.3.2.1 Diffserv Code Point

DSCP priority value to be used for marking of internal management traffic. The range is 0-63. The default is 0.

A change in Diffserve Code Point will take effect after next reset.

3.7.2.6.3.2.2 802.1p Priority

802.1p priority value to be used for marking of internal management traffic. The range is 0-7. The default is 0.

A change in 802.1p Priority will take effect after next reset.

3.7.2.6.3.3 QOS Rules

The QOS Rules menu includes the following options:

- Show: Use the Show option to view the main parameters (Rule Status, Marking Rule Name, Service Flow Data Delivery Type, Service Flow Traffic Priority) of each of the existing QoS Rules.
- Add: Use the Add option to add a new QoS Rule. The change will take effect after next reset.
- Select: Use the Select option to select a specific QoS Rule by its Rule Number. You can then select one of the following:
 - » Use the Show option to view all parameters of the selected rule.
 - » Use the Update option to update one or several parameters of the selected rule. Rule is selected by the Rule Number. Change in a QoS Rule will take effect after next reset.
 - » Use the Delete option to remove the selected rule from the database. The change will take effect after next reset.

The QOS Rule parameters are:

3.7.2.6.3.3.1 Rule Number

The index number of the rule. A number in the range 1-16383. The Rule Number of an existing rule cannot be modified.

3.7.2.6.3.3.2 Rule Status

The status of the rule (Enable or Disable).

3.7.2.6.3.3.3 Marking Rule Name

The name of the QoS Marking Rule. An optional string of up to 32 characters.

A change in Marking Rule Name will take effect after next reset.

3.7.2.6.3.3.4 Service Flow Data Delivery Type

The Service Flow Type for data delivery services: ugs, rtvr, nrtvr, be, ertvr, or any.

A change in Service Flow Data Delivery Type will take effect after next reset.

3.7.2.6.3.3.5 Service Flow Traffic Priority

The priority of Service Flow traffic. 0-7 or ANY (255).



A change in Service Flow Traffic Priority will take effect after next reset.

3.7.2.6.3.3.6 Service Flow Media Flow Type

The Service Flow Media Flow Type, as defined in ASN-GW or AAA server. Optional parameter (depending on value configured for Enable Service Flow Media Flow Type below), up to 32 characters.

A change in Service Flow Media Flow Type will take effect after next reset.

3.7.2.6.3.3.7 Enable Service Flow Media Flow Type

Indicates whether the condition for Service Flow Media Flow Type is enabled or disabled. If true, the Service Flow Media Flow Type will be considered. when looking for a match.

A change in Enable Service Flow Media Flow Type will take effect after next reset.

3.7.2.6.3.3.8 Outer DSCP Marking

The DSCP value to be used for marking the outer IP header (IP/GRE). The range is 0-63.

A change in Outer DSCP Marking will take effect after next reset.

3.7.2.6.3.3.9 802.1p Priority Marking

The 802.1p priority to be used for marking traffic. The range is 0-7.

A change in 802.1p Priority Marking will take effect after next reset.

3.7.2.6.4 ASN-GW Load Balancing

At the BTS level, up to two pools (with different priorities), each with up to 10 ASN-GWs, can be defined (see [“ASN-GW Load Balancing Pools” on page 49](#)). The BS will “inherit” these pools. It should be noted the ASN-GW defined in the BS as the Default Authenticator will be automatically added to the Primary Pool that is the higher priority pool (although it will not be shown as belonging to the pool).

At the BS level, you can enable/disable the use of each of the two pools. The Secondary Pool can be enabled only if the Primary Pool is enabled and includes at least one entry. Note that if both pools are disabled, or if the enabled pool(s) are empty, the ASN-GW load balancing feature is disabled and only the Default Authenticator will be used.

The ASN-GW Load Balancing menu includes the following options:

- [Pools Availability](#)
- [Primary Pool](#)
- [Secondary Pool](#)

3.7.2.6.4.1 Pools Availability

The Pools Availability option enables viewing/updating the status (Enabled/Disabled) of each of the pools. The Secondary Pool can be enabled only if the Primary Pool is enabled.

A change in a Pool Availability will take effect after next reset.

3.7.2.6.4.2 Primary Pool

The Primary Pool option enables viewing the IP Address and current Connectivity Status for each of the ASN-GWs in the pool, based on selection of the ASN-GW Index.



3.7.2.6.4.3 Secondary Pool

The Secondary Pool option enables viewing the IP Address and current Connectivity Status for each of the ASN-GWs in the pool, based on selection of the ASN-GW Index.

3.7.2.7 Management Thresholds

The Management Thresholds menu includes the following option:

- [Noise and Interference Level Thresholds](#)

3.7.2.7.1 Noise and Interference Level Thresholds

The Noise and Interference Level Thresholds menu enables viewing/updating the values configured for the following parameters:

- [Uplink Median Noise](#)
- [Throughput Active Second Threshold](#)

3.7.2.7.1.1 Uplink Median Noise

The uplink median noise level represents the median value of the noise floor histogram. If the uplink median noise level exceeds this value, an excessive uplink median noise alarm will be generated.

The value is in dBm/ton. The default value of -124 is set to 3 dB above the default value of the Target NI parameter.

The range is from -135 to -100 (dBm).

3.7.2.7.1.2 Throughput Active Second Threshold

The BS Traffic Performance Parameters counters collected by the file collection mechanism include throughput counters (bsDIMimoABfActualThroughput, bsDIMimoBActualThroughput, bsUIActualThroughput). These counters collect the number of bytes transmitted/received during each 15 minutes collection interval using different modulation techniques, and the relevant numbers of "active" seconds. "Active seconds are defined as seconds during which the relevant throughput was not below a the threshold defined by the Throughput Active Second Threshold.

The range is from 0 to 2147483647 bytes per second.

The default is 0.

3.7.2.8 Keep Alive

The Keep Alive menu enables viewing/updating the values configured for the following parameters of the keep-alive mechanism between the BS and the relevant ASN-GWs:

- [Enable Keep Alive](#)
- [Polling Period](#)
- [Number of Retransmissions](#)
- [Retransmissions Time Out](#)



3.7.2.8.1 Enable Keep Alive

Enable/disable the keep-alive mechanism. The default is Enable.

The following parameters are applicable only if Keep Alive is enabled.

3.7.2.8.2 Polling Period

The period in seconds between polling sessions.

The range is from 10 to 1000 seconds. The default is 60 seconds.

Polling Period x 1000 (value in milliseconds) cannot be lower than (Retransmissions Time Out) x (Number of Retransmissions+1).

3.7.2.8.3 Number of Retransmissions

Maximum number of retries if Retransmission Timeout has expired without getting a response.

The range is from 0 (none) to 10. The default is 5.

3.7.2.8.4 Retransmissions Time Out

Time in milliseconds to wait for a response before initiating another polling attempt or reaching a decision that the polled entity has failed (if the maximum number of retries set by Number of Retransmissions has been reached).

The range is from 5000 to 10000 milliseconds (5 to 10 second). The default is 5000.

3.7.2.9 Scheduler

Scheduling uncommitted (above the maximum reserved rate) traffic can be done using one of the following options:

- Equal Time (ET) scheduling mode, in which air resources are being scheduled in a fair manner proportional to the users' excess traffic (maximum sustained rate - maximum reserved rate) SLAs.
- Equal Rate (ER) scheduling mode, in which air resources are allocated to users aiming at ensuring data rate fairness between users proportional to their excess traffic SLAs.

Assuming a sector with diversity (different channels conditions) of active users, ET scheme enables higher aggregate sector throughput at the expense of data-rate fairness among users, while ER scheduling scheme ensures maximum data-rate fairness among users at the expense of lower aggregate sector throughput.

Using ER scheduling scheme exposes the system to excessive allocation of air resources to highly active users having relatively poorer channel conditions. To ensure data-rate fairness, more resources will be allocated to these users compared to users with relatively good channel conditions. The effect of a small number of such users within the sector will be reflected by reduced aggregate sector throughput as well as degradation of achievable rates for all users.

To protect against "abusing" users, an instantaneous rate threshold can be defined within the scheduling scheme in which the amount of air resources for users with continuous instantaneous rate below the threshold is being limited. The more the abusing users' instantaneous rate is below the threshold, the more resource allocations limitation is applied.



Three levels of dynamic protection are available:

- No protection.
- Low protection level - Protection against users with very poor channel conditions. Should be used where the abusing users instantaneous rates are far below the average instantaneous rate within the sector.
- Medium protection - Protection against users with relatively poor or very poor channel conditions. Should be used where the abusing users instantaneous rates are below or far below the average instantaneous rate within sector.

A dynamic protection mechanism is implemented, in which the mechanism of limiting resource allocations is automatically and dynamically activated when needed.

The Scheduler menu enables viewing/updating the values configured for the following parameters:

- [Scheduler Mode](#)
- [Scheduler DL Abuse Protection Level](#)
- [Scheduler UL Abuse Protection Level](#)

3.7.2.9.1 Scheduler Mode

The basis for allocating excess bandwidth among relevant users:

- Equal Rate: Throughput Fairness
- Equal Time: Resource Fairness

The selected mode is applicable for both uplink and downlink schedulers.

The default is Equal Rate.

A change in Scheduler Mode will take effect after next reset.

3.7.2.9.2 Scheduler DL Abuse Protection Level

Applicable only if the selected Scheduler Mode is Equal Rate.

- None: No Protection
- Low: Limit the DL resources allocated to MSs with very low DL transmission Rate.
- Medium: Limit the DL resources allocated to MSs with low and very low DL transmission Rate.

The default is None.

A change in Scheduler DL Abuse Protection Level will take effect after next reset.

3.7.2.9.3 Scheduler UL Abuse Protection Level

Applicable only if the selected Scheduler Mode is Equal Rate.

- None: No Protection
- Low: Limit the UL resources allocated to MSs with very low UL transmission Rate.
- Medium: Limit the UL resources allocated to MSs with low and very low UL transmission Rate.



The default is None.

A change in Scheduler UL Abuse Protection Level will take effect after next reset.



3.8 Chassis Menu

The Chassis menu includes the following options:

- [General](#)
- [Ports Control](#)

3.8.1 General

The Chassis General menu enables viewing the following read-only general Chassis properties and status:

- HW Version
- Serial Number
- Temperature (°C)
- Operational SW Version
- Shadow SW Version
- Running SW Version: The source of the current running SW version (operational/Shadow)
- Boot SW Version
- Active Data Port MAC Address: The MAC address of the active Data port
- Data Three MAC Address: The MAC address of Data Port 3
- Topology Type: The Topology Type used by the unit. In the current release only One Sector One Carrier topology (see [“One Sector, One Carrier”](#) on page 10) is supported.
- Maximal Frame Size (see details below)
- SFP Product Type: The installed SFP type (in any) in DAT1 port. The available options include approved SFP types, none (SFP not installed), notVerified (a non-approved SFP).

The Chassis General menu also enables viewing/updating the following parameter:

3.8.1.1 Maximal Frame Size

The maximal size (excluding preamble) of frames on the Ethernet port.

The range is from 1400 to 9000 Bytes.

The default is 1578 Bytes.

A change in Maximal Frame Size will take effect after next reset.

3.8.2 Ports Control

The Chassis Ports Control menu enables controlling the operation mode of each RF port.



For each of the four ports, the following options for the Shutdown Power Port # (1-4) parameter are available:

- **shutDown**: Select to shut down power to the port.
- **noShutDown**: Normal operation.
- **rxOnly**: Disable transmission on the port (enable only receive functionality).

The default status for all ports is normal operation (noShutDown).

A change in Shutdown Power Port # parameter will take effect after next reset.

In the current release the following configuration options are applicable:

- 1** 4Rx by 4Tx -: All 4 ports should be configured for Tx/Rx operation (noShutDown).
- 1** 4Rx by 2Tx (4x2) configuration: 2 ports should be configured for Tx/Rx operation (noShutDown), and the 2 other ports should be configured for Rx Only operation (rxOnly). Different antenna polarities should be connected to the 2 Tx/Rx ports.
- 2** 2Rx by 2Tx (2x2) configuration (applicable for both COMPACT and COMPACT HP): 2 ports should be configured for Tx/Rx operation (noShutDown), and the 2 other ports should be disabled (shutDown). Different antenna polarities should be connected to the 2 Tx/Rx ports.

Refer to Installed RH Type (in [“RH Menu” on page 88](#)) for details on ports configuration supported by each Radio Head.



3.9 GPS Menu

The GPS menu includes the following options:

- [General Configuration](#)
- [Inventory & Statuses](#)

3.9.1 General Configuration

The GPS General Configuration menu enables viewing/updating the following parameters:

3.9.1.1 GPS Type

The type of time synchronization source to be used. The currently available options are None and TrimbleLassen.

The default is TrimbleLassen.

A change in GPS Type will take effect after next reset.

3.9.1.2 Longitude

The longitude of the site. The format is ll.mmm,a: ll.is longitude in degrees (between 000 to 179); mmm is in minutes (between 000 and 999); a - is E (east) or W (west). The default is 000.000,E.

Configurable only if GPS Type set to None. Otherwise it is read-only, displaying the value calculated by the GPS receiver.

3.9.1.3 Latitude

The latitude of the site. The format is ll.mmm,a: ll.is latitude in degrees (between 00 to 89); mmm is in minutes (between 000 and 999); a - is N (north) or S (south). The default is 00.000,N.

Configurable only if GPS Type set to None. Otherwise it is read-only, displaying the value calculated by the GPS receiver.

3.9.1.4 Altitude

The altitude in meters of the site in meters, from -300.0 to 9000.0. The default is 0.

Configurable only if GPS Type set to None. Otherwise it is read-only, displaying the value calculated by the GPS receiver.

3.9.1.5 UTC Time and Date

The UTC (Coordinated Universal Time) date and time. Configurable only if the GPS Type is set to None. Otherwise it is the read-only data received from the GPS receiver.

The format is hh: mm: ss,dd/mm/yyyy

hh (hours) between 0 and 23, mm (minutes) between 0 and 59, ss (seconds) between 0 and 59, dd/mm with usual date and month rules, yyyy is the year.



3.9.1.6 Time Zone Offset From UTC

The offset of the local time from the UTC.

The range is -12:00 to +13:00 in 30 minutes resolution. The default is +00.00.

3.9.1.7 Local Time and Date

A read-only display of the local date and time (using 24-hour clock) as calculated using the UTC Time and Date and taking into account the Time Zone Offset From UTC and Daylight Saving Time parameters. The format is: hh:mm:ss; dd/mm/yyyy.

3.9.1.8 Daylight Saving Mode

The Daylight Saving Mode parameter is used to enable or disable the daylight saving feature using the following Start Date, Stop Date and Advance Hour Factor parameters. The default is Disable.

A change in Daylight Saving Mode will take effect after next reset.

3.9.1.9 Advance Hour Factor

When Daylight Saving is enabled, this parameter defines the amount of time by which the clock should be advanced during the daylight saving period.

The available values are 0 (daylight saving disabled), 1 and 2 (hours). The default is 0.

3.9.1.10 Start Date

When Daylight Saving is enabled, this parameter defines the date for starting the daylight saving feature. At the beginning of this date (midnight at the beginning of this date), the clock will be advanced by the amount of hours specified by the Advance Hour Factor.

Use the format dd.mm to define the date and month at which to start activating the Daylight Saving feature.

A change in Start Date will take effect after next reset.

3.9.1.11 Stop Date

When Daylight Saving is enabled, this parameter defines the date for ending the daylight saving feature (at "Advance Hour Factor" hours after midnight at the end of this date).

Use the format dd.mm to define the date and month at which to end activating the Daylight Saving feature.

A change in Stop Date will take effect after next reset.

3.9.1.12 External 1PPS

Indicates whether the external 1PPS clock is enabled or disabled.



If the External 1PPS clock is enabled, synchronization of air frames for inter-site and intra-site sectors should be managed by the external 1PPS clock. If the External 1PPS clock is disabled, it indicates that the internal 1PPS clock is used to synchronize air frames for inter-site and intra-site sectors.

When using a GPS, External 1PPS clock must be enabled for proper operation of the system.

The default is Enable.

A change in External 1PPS will take effect after next reset.

3.9.1.13 Hold Over Passed Timeout

Applicable only when External 1PPS is enabled. Defines the period, in minutes, for which the device provides holdover using its internal 1PPS clock after loss of the external 1PPS signal. This parameter is not relevant if Stop TX After Hold Over Timeout (see below) is disabled.

The range is from 0 to 120 minutes. The default is 120 minutes.

3.9.1.14 Stop TX After Hold Over Timeout

Applicable only when External 1 PPS is enabled. Indicates whether the BTS should stop data transmission if the unit does not receive an external 1 PPS signal and the holdover passed timeout has occurred. When enabled, the BTS will stop transmitting after being in holdover state for more than Hold Over Passed Timeout.

The default is Enable.

3.9.2 Inventory & Statuses

The Inventory & Statuses menu, enables viewing the following read-only properties and status parameters:

3.9.2.1 Navigation Processor SW Version

The software version of the navigation processor of the GPS receiver (if GPS is used and operates properly).

3.9.2.2 Signal Processor SW Version

The software version of the signal processor of the GPS receiver (if GPS is used and operates properly).

3.9.2.3 Number Of Satellites

The number of satellites currently acquired by the GPS receiver (if GPS is used and operates properly).

3.9.2.4 External 1PPS failure

The status of External 1PPS clock (received from the GPS receiver when synchronized if a GPS receiver is used).



3.9.2.5 4 Satellites and more

Indicating whether 4 (the minimum required for initial synchronization) or more satellites are received by the GPS receiver (if GPS is used and operates properly).

3.9.2.6 2 Satellites and more

Indicating whether 2 (the minimum number required for maintaining synchronization after establishing initial synchronization) or more satellites are received by the GPS receiver (if GPS is used and operates properly).

3.9.2.7 GPS communication failure

Indicating the status of communication with the GPS receiver (if GPS is used and operates properly).

3.9.2.8 Hold Over Entered

Indicating whether the device has entered into Hold Over state.

3.9.2.9 Hold Over timeout passed

Indicating whether Hold Over Timeout has passed (applicable only after entering Hold Over state).

3.9.2.10 BS stopped to transmit

Indicating whether the BSs stopped transmitting due to being in Hold Over state for a period longer than Hold Over Timeout.

3.9.2.11 Internal 1PPS failure

The status of the Internal 1PPS clock.



3.10 RH Menu

The RH (Radio Head) menu includes the following options:

- General
- Ports

3.10.1 General

The RH General menu enables viewing the following read-only general radio head properties:

- **Installed RH Type:** RH Type is in the format rhAAAABBBBZZZWPPRbyTCO, where:
 - » AAAA = Lower bound of frequency band in MHz, rounded up to the nearest integer.
 - » BBBB = Upper bound of frequency band in MHz, rounded down.
 - » ZZZ = always 000 in TDD systems.
 - » W = always N in TDD systems.
 - » PP = maximum transmit power in dBm, rounded down.
 - » R = number of receive channels.
 - » T = number of transmit channels.
 - » C = Y if cavity filter or a gap in the band is present, N if not.
 - » O = Reserved (0).

INFORMATION In the current release the following Radio Head Types are supported:



- COMPACT -
 - » rh34003675000N274by4N0 (3400-3675 MHz, 27 dBm, 4Rx by 4Tx)
 - » rh34003600000N304by4N0 (3400-3600 MHz, 30 dBm, 4Rx by 4Tx)
 - » rh33003800000N304by4N0 (3300-3800 MHz, 30 dBm, 4Rx by 4Tx)
 - » rh34003700000N304by4N0 (3400-3700 MHz, 30 dBm, 4Rx by 4Tx)
 - » rh33003500000N304by4N0 (3300-3500 MHz, 30 dBm, 4Rx by 4Tx)
 - » rh36003800000N304by4N0 (3600-3800 MHz, 30 dBm, 4Rx by 4Tx)
- COMPACT HP (High Power):
 - » rh34003600000N384by2N0 (3400-3600 MHz, 37 dBm, 2Rx by 2Tx)

- **Serial Number**

The RH General menu also enables viewing/updating the following parameter:



3.10.1.1 External Cavity Filter Existence

Informational parameter indicating whether an external cavity filter exists (true/false). The default is false (external filter does not exist).

3.10.2 Ports

The RH Ports menu enables viewing the general port status parameters for all ports or for a selected radio ports:

3.10.2.1 Calculated TX Power

The required Tx power at the radio port, in dBm. Calculated according to the Tx Power configured for the Radio Cluster and the Topology Type. In the current release (supporting only One Sector One Carrier topology) the RH Port Calculated Tx Power equals the Radio Cluster's Tx Power.

3.10.2.2 RH Status Mask

Read-only. A decimal number representing the value of a 32-bits mask (bits 0-31) indicating possible failures. Applicable only for an installed and associated RH. For a No Failure status the value is 0. If the value is other than 0 contact Customer Support.



3.11 Antenna Menu

Up to 4 antennas can be defined. The Antenna menu enables viewing parameters of all defined antennas, adding an antenna, and selecting an antenna for viewing/updating its parameters or deleting it.

If an antenna is associated to a Sector, it cannot be deleted.

When adding a new antenna, you will be prompted to configure all parameters.

By default, one Antenna object exists, with the following properties:

- Antenna Number: 1
- Antenna Product Type: default1portV
- Mechanical Down Tilt: 0
- Electrical Down Tilt: 0
- Longitude: 000.000,E
- Latitude: 00.000,N
- Height: 0
- Heading: 0
- Cable Loss: 0.5

The Antenna parameters are:

3.11.1 Antenna Number

A unique number in the range 1-4.

3.11.2 Antenna Product Type

The identification name of the antenna. The available options includes a list of default and standard antennas. The default is default1portV.

If the Antenna is associated to a Sector, the Antenna Product Type cannot be modified.

3.11.3 Mechanical Down Tilt

The downwards mechanical tilt of the antenna (in degrees) as opposed to the electrical tilt already integrated in the antenna (and thus taken as reference; instead of the horizontal plane). The range is from -90.0 to 90.0 using 0.1 degree resolution. Used only for information (inventory) purposes.

3.11.4 Electrical Down Tilt

The downwards electrical tilt of the antenna, in degrees. The range is from -90.0 to 90.0 using 0.1 degree resolution. Used only for information (inventory) purposes.



3.11.5 Longitude

The longitude of the antenna. The format is `lll.mmm,a`: `lll` is longitude in degrees (between 000 to 179); `mmm` is in minutes (between 000 and 999); `a` - is E (east) or W (west) Used only for information (inventory) purposes.

3.11.6 Latitude

The latitude of the antenna. The format is `ll.mmm,a`: `ll` is longitude in degrees (between 00 to 89); `mmm` is in minutes (between 000 and 999); `a` - is S (south) or N (north). Used only for information (inventory) purposes.

3.11.7 Tower Height

The height of the antenna above the ground in meters. The range is from 0 to 500. Used only for information (inventory) purposes.

3.11.8 Heading

The the azimuth angle (in degrees) between the center of the horizontal antenna beamwidth and the true north; counting clockwise. The range is from 0 to 359. Used only for information (inventory) purposes.

3.11.9 Cable Loss

The attenuation (in dB) of the cable between the radio port and antenna port. The range is from 0 to 20 in 0.1 dB steps. Used only for information (inventory) purposes.