



**PHONECELL® SX6P-200C CDMA**

---

**Fixed Cellular Phone**

***USER MANUAL***



## QUICK CONNECTION GUIDE

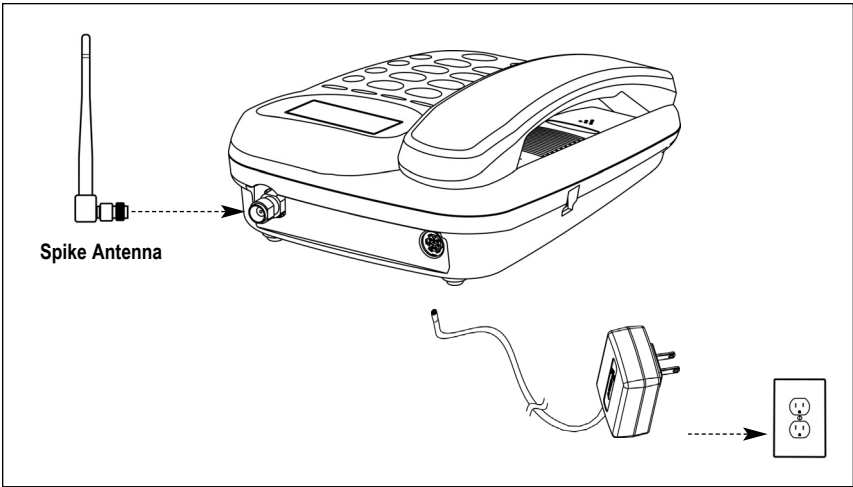

Phonecell SX6P-200C Fixed Cellular Phone

## LIST OF COMPONENTS



Phonecell® SX6P  
Desktop Phone



Spike Antenna



AC Power Cube

Before installing your **Phonecell® SX6P**, carefully remove the contents from the shipping carton and check for evidence of shipping damage. **If damage is found, contact your Authorized Telular Distributor or shipping agent immediately.**

# SX6P MENU STRUCTURE

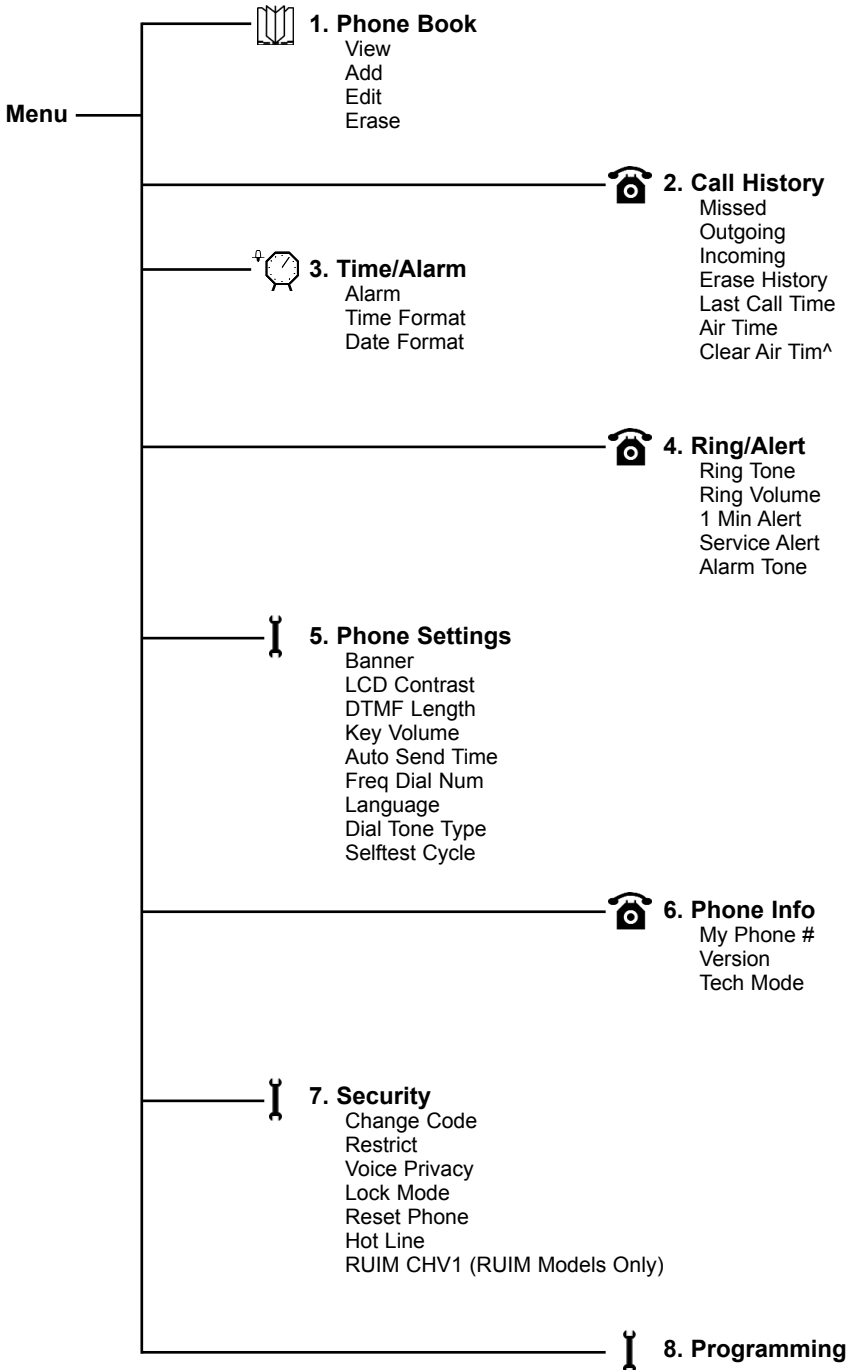

## **SAFE OPERATION INSTRUCTIONS**

**IMPORTANT!** Before installing or operating this product, read the **SAFETY INFORMATION** section of this manual.

- Install unit indoors.
- Install unit on hard, flat surface for proper ventilation.
- Do not expose unit to rain or moisture.
- Do not place unit on or close to sources of heat.

Please see the **IMPORTANT NOTICES**, **SAFETY INFORMATION**, and **WARRANTY** sections of this manual for important information on use, warranty, and indemnification.

## **IMPORTANT NOTICES**

### **TERMS AND CONDITIONS FOR USE OF PHONECELL® PRODUCTS ("Product")**

These Terms and Conditions are a legal contract between you and Telular Corporation for the title to and use of the Product. BY RETAINING AND USING THE PRODUCT AFTER RECEIPT OF IT, YOU AGREE TO THE TERMS AND CONDITIONS INCLUDING WARRANTY DISCLAIMERS, LIMITATIONS OF LIABILITY AND INDEMNIFICATION PROVISIONS BELOW. IF YOU DO NOT AGREE TO THE TERMS AND CONDITIONS, DO NOT USE THE PRODUCT AND IMMEDIATELY RETURN THE UNUSED PRODUCT FOR A COMPLETE REFUND. You agree to accept sole responsibility for any misuse of the Product by you; and, in addition, any negligent or illegal act or omission of your or your agents, contractors, servants, employees, or other users of the Product so long as the Product was obtained from you, in the use and operation of the Product.

### **INDEMNIFICATION OF TELULAR CORPORATION ("TELULAR")**

**YOU SHALL INDEMNIFY, DEFEND AND HOLD HARMLESS TELULAR FOR ANY OF THE COST, INCLUDING REASONABLE ATTORNEYS' FEES, AND FROM CLAIMS ARISING OUT OF YOU, YOUR CLIENTS' OR OTHER THIRD PARTIES' USE OR OPERATION OF THE PRODUCT: (i) FOR MISUSE OR IN A MANNER NOT CONTEMPLATED BY YOU AND TELULAR OR INCONSISTENT WITH THE PROVISIONS OF THIS MANUAL; (ii) IN AN ILLEGAL MANNER OR AGAINST PUBLIC POLICY; (iii) IN A MANNER SPECIFICALLY UNAUTHORIZED IN THIS MANUAL; (iv) IN A MANNER HARMFUL OR DANGEROUS TO THIRD PARTIES; (v) FROM CLAIMS BY ANYONE RESPECTING PROBLEMS, ERRORS OR MISTAKES OF THE PRODUCT; OR (vi) COMBINATION OF THE PRODUCT WITH MATERIAL, MODIFICATION OF THE PRODUCT OR USE OF THE PRODUCT IN AN ENVIRONMENT NOT PROVIDED, OR PERMITTED, BY TELULAR IN WRITING. THE PARTIES SHALL GIVE EACH OTHER PROMPT NOTICE OF ANY SUCH COST OR CLAIMS AND COOPERATE, EACH WITH THE OTHER, TO EFFECTUATE THIS INDEMNIFICATION, DEFENSE AND HOLD HARMLESS.**

**TELULAR CORPORATION**  
**Corporate Headquarters**  
647 North Lakeview Parkway  
Vernon Hills, Illinois 60061, USA  
<http://www.telular.com>

# Table of Contents

<b>Quick Connection Guide</b> .....	<b>i</b>
<b>List of Components</b> .....	<b>i</b>
<b>SX6P Menu Structure</b> .....	<b>ii</b>
<b>Safe Operation Instructions</b> .....	<b>iii</b>
<b>Important Notices</b> .....	<b>iii</b>
<b>SX6P Setup</b> .....	<b>1</b>
RUIM Card Installation (RUIM Model Only) .....	1
Battery Installation .....	2
Battery Operation .....	2
Location and Setup .....	2
Connecting the Handset .....	3
Wall Mounting .....	3
Connecting the SX6P to AC Power .....	4
RUIM Usage (RUIM Models Only) .....	5
<b>Getting to Know Your SX6P</b> .....	<b>6</b>
Function Keys .....	6
LCD Screen Icons .....	7
Service Indication .....	7
<b>Call Functions</b> .....	<b>8</b>
Making Calls .....	8
Receiving Calls .....	8
Ending Calls .....	8
In-Call Functions .....	8
Voicemail Access .....	9
Reading Text (SMS) Messages .....	9
Sending a Text Message .....	10
Deleting All Text Messages .....	10
Using Message Lock .....	10
Activating Message Alert .....	10
<b>Phone Book</b> .....	<b>11</b>
Speed Dialing by Location .....	11
Searching the Phone Book and Dialing a Phone Book Entry .....	11
Adding a New Phone Book Entry .....	11
Editing a Phone Book Entry .....	12
Erasing a Phone Book Entry .....	12
<b>Call History</b> .....	<b>12</b>
Viewing Missed Calls .....	12
Viewing Outgoing Calls .....	12
Viewing Incoming Calls .....	12
Erasing All Call History .....	12
Viewing Last Call Time .....	13
Viewing Total Air Time .....	13
Clearing Air Time .....	13
<b>Time / Alarm</b> .....	<b>13</b>
Alarm .....	13
Time Format .....	13
Date Format .....	13
<b>Ring / Alert</b> .....	<b>14</b>
Ring Tone .....	14
Ring Volume .....	14
One Minute Alert .....	14
Service Alert .....	14
Alarm Tone .....	14

<b>Phone Settings</b> .....	<b>15</b>
Banner .....	15
LCD Contrast .....	15
DTMF Length .....	15
Key Volume .....	15
Auto Send Time .....	15
Frequently Dialed Number .....	15
Change Language Displayed On LCD .....	16
Dial Tone Type .....	16
Self Test Cycle .....	16
<b>Phone Info</b> .....	<b>16</b>
My Phone # (display only) .....	16
Software Version Information .....	16
Tech Mode .....	16
<b>Security</b> .....	<b>17</b>
Change Code .....	17
Restrict Outgoing Calls .....	17
Voice Privacy .....	17
Lock Mode .....	17
Reset Phone .....	18
Hotline .....	18
RUIM CHV1 (RUIM Models Only) .....	18
<b>SX6P Troubleshooting</b> .....	<b>20</b>
<b>Conformance Statements</b> .....	<b>21</b>
<b>Safety Information</b> .....	<b>21</b>





## **SX6P Setup**

### **RUIM Card Installation (RUIM Model Only)**

Consult your service provider to determine if your unit requires the use of a RUIM (Removable User Identity Module). If it is a RUIM model, your SX6P will only be able to place emergency calls until you install a RUIM card. It will not receive calls or allow non-emergency outgoing calls without the RUIM card installed. For an explanation of how to configure your RUIM once your SX6P is set up, see **RUIM Usage** on page 5.

1. Remove the power cord if it has already been connected. The power cord must be removed whenever a RUIM Card is removed or installed.
2. Remove the RUIM compartment cover. - **see Figure 1.**
3. Open the RUIM compartment holder.
4. Line up the RUIM card with the arrow on the RUIM card holder - **see Figure 2.**
5. Gently insert the RUIM card in the slot of the RUIM card holder.
6. Close the RUIM card holder.

**Note:** Do not force the RUIM card holder shut. Make sure the RUIM card is aligned properly with the directional arrow on the holder.

7. Reattach the RUIM compartment cover, closing it with the separate cover screw provided.

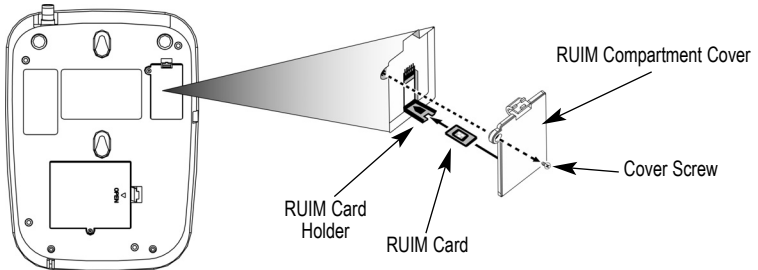

**Figure 1** - RUIM compartment cover.

**Figure 2** - RUIM card installation.

## Battery Installation

**Note:** The battery is an optional accessory that may or may not be available. Consult your service provider.

1. If necessary, remove the screw that may be holding the battery access door located on the bottom of the unit - **see Figure 3**.
2. Press the battery access door tabs and remove the battery access door.
3. Install the Telular rechargeable battery pack into the battery pack area and connect wires.
4. Reinstall the battery access door using the screw - **see Figure 4**.

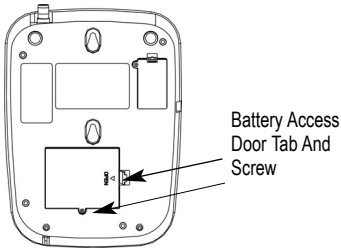

Figure 3 – Battery access door.

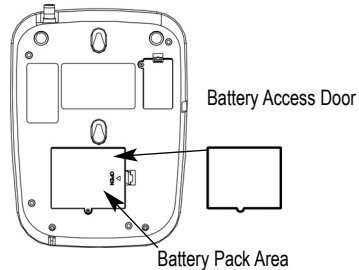

Figure 4 - Battery installation.



### **WARNING!**

*Do not use batteries other than the Telular battery pack included with the SX6P. Using any other batteries may result in fire and/or other damage to the unit.*

## Battery Operation

The SX6P will recharge its battery pack when connected to AC power. If AC power is interrupted, the SX6P will continue to operate, using power from the battery.

## Location and Setup

The SX6P comes with a standard spike antenna (TNC – Terminal Node Controller).

1. Attach and finger-tighten the antenna - **see Figure 5**. Do not over-tighten the antenna.
2. Select a location that is above ground and as close to windows (or exterior walls) as possible to get the best signal - **see Figure 6**.

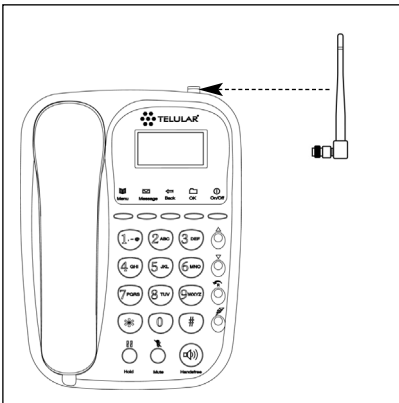

Figure 5 - Attach the antenna.

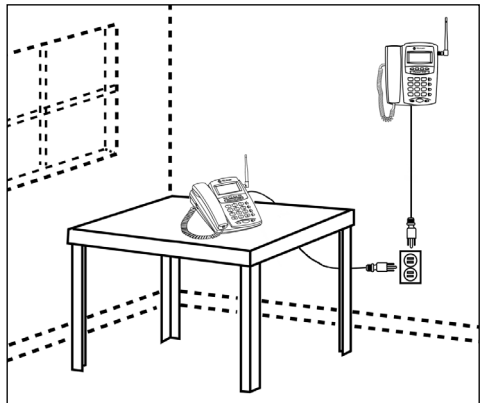
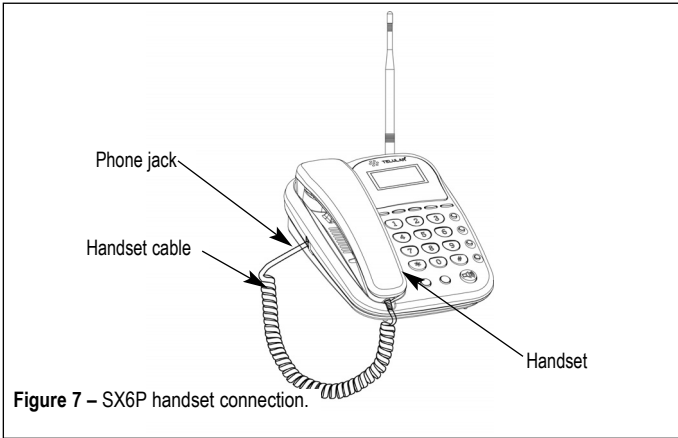

Figure 6 - SX6P location.

## Connecting the Handset

Before you use can use the SX6P, you must connect the handset cable.

1. Connect the handset cable to the phone jack - **see Figure 7.**
2. Connect the handset cable to the handset - **see Figure 7.**



## Wall Mounting

1. Remove the mounting clip from the cradle and re-insert it with the tab pointing up - **see Figures 8 and 9.**

Mounting Clip in  
Cradle (tab up)

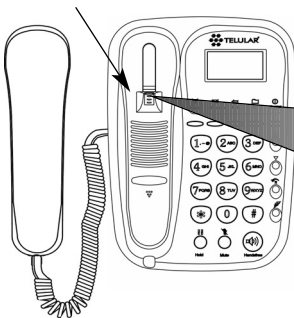

**Figure 8 – Handset mounting clip assembly.**

Remove  
Mounting Clip  
from the Cradle  
(tab down)

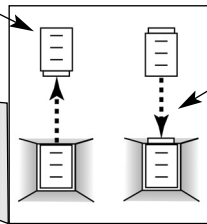

Insert  
Mounting  
Clip into  
the Cradle  
(tab up)

**Figure 9 – Handset mounting clip for wall-mount.**

2. Mark two hole locations 83 mm (3-1/4 inches) vertically apart and drill two holes into the wall.

3. Install the screws (not supplied) into the wall, leaving a gap of approximately 3 mm (1/8 inches) between the screw head and the wall.
4. Align the mounting holes with the screws and mount the SX6P onto the screws - **see Figures 10 and 11.**

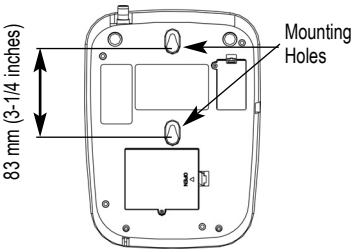

Figure 10 – SX6P mounting hooks.

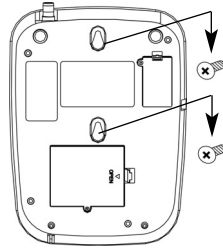

Figure 11 – Mount the SX6P onto the screws.

### Connecting the SX6P to AC Power

1. Connect the DIN connector of the AC power cord into the AC power input on the rear panel of the SX6P - **see Figure 12.**
2. Plug the AC power cube into the wall socket.
3. Check the cellular signal strength and move the unit until the best signal possible is achieved - see the **Service Indication** section of this manual on page 7.

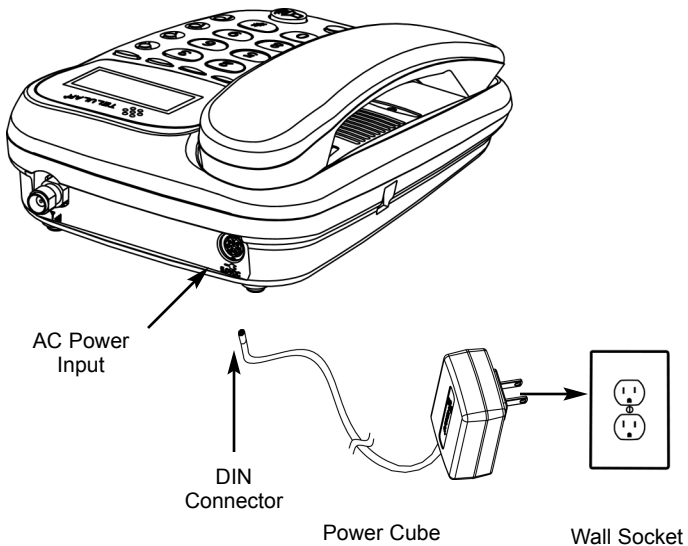

Figure 12 – SX6P AC power connection

## **RUIM Usage (RUIM Models Only)**

Your service provider may require you to install a RUIM (Removable User Identity Module) in your SX6P for it to operate normally (see **RUIM Card Installation** on page 1 for details). Without a RUIM, these SX6P models will reject incoming calls and allow only emergency outgoing calls.

Once a RUIM-using SX6P is operating normally, you can use it to set its RUIM to require a PIN (Personal Identification Number, also called Cardholder Verification, or CHV), not require a PIN, or change the existing PIN. See **Security** (page 17) for details.

### **Starting Your SX6P with a RUIM PIN**

**If your RUIM requires a PIN, follow these steps:**

1. Power on your SX6P.
2. The SX6P will prompt you to enter your PIN. Enter the PIN for your RUIM, then press  [Store].
3. If you enter the wrong PIN, the SX6P will display an error message and ask you to reenter the PIN.
4. Entering an incorrect PIN three times will cause the SX6P to block the inserted RUIM. If your RUIM is blocked due to incorrect PIN use, it will prompt you to enter the unblocking code. You must contact your service provider to obtain this unblocking code. Do not guess at the block code or use your own PIN to attempt to unblock the SX6P; entering wrong codes will eventually cause the RUIM to become permanently blocked.
5. If you are unable to enter the correct PIN for the inserted RUIM, the SX6P will not operate normally. It will reject incoming calls and permit only emergency outgoing calls.

### **Starting Your SX6P if Your RUIM Requires No PIN**

Power on your SX6P. No additional steps are necessary.

### **Starting Your SX6P if it is Bonded to a RUIM**

An SX6P may be bonded to a specific RUIM. Once it has been bonded, the SX6P will not operate normally with any other RUIM installed in it. It will reject incoming calls and permit only emergency outgoing calls. The same holds true for any other SX6P that the bonded RUIM is installed into: it will not operate normally.

To start a bonded SX6P, power it on. No additional steps are necessary if the correct RUIM is inserted into the SX6P.

If you want to bond an SX6P to an RUIM, contact your service provider.

# Getting to Know Your SX6P

## Function Keys

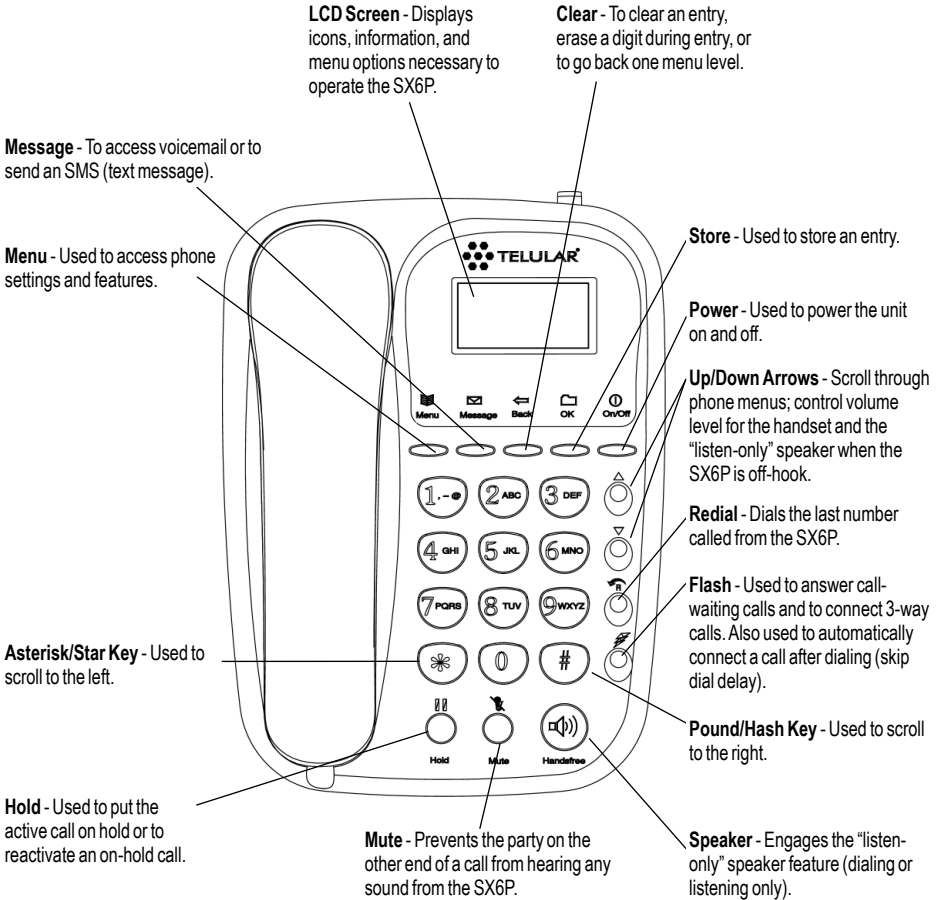

Figure 13 – SX6P keypad and function keys.

## LCD Screen Icons

Icons displayed on the LCD screen indicate the features that are in use, the status of the phone, signal strength and battery status - *see Figure 14*.

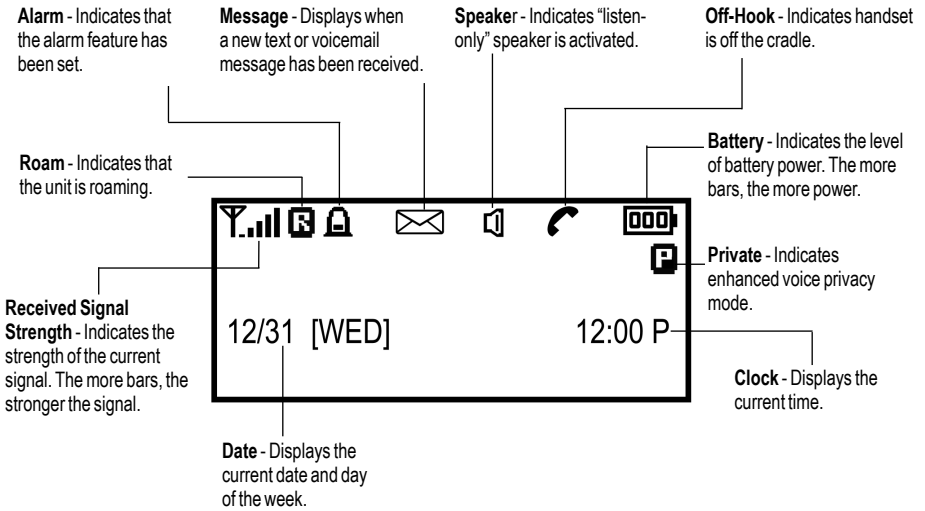

Figure 14 – SX6P LCD screen icons.

## Service Indication

### Full Service

When powered on, the banner and current date and time will display. If service is available, the antenna icon will display indicator bars. The number and height of the indicator bars increases as the signal grows stronger (the more bars, the better the signal).

### No Service



When no service is available, the antenna icon will not display indicator lines. Contact your service provider to verify cellular service is activated. No calls can be made in this condition.

# Call Functions



## **Making Calls**

1. Pick up the handset or press  [Speaker] (listening only). The SX6P is now “off-hook.”
2. Listen for dial tone.
3. Dial the phone number. The dialed number will be displayed. The name will also be displayed if it is stored in the phone book.

## **Correcting Dialing Errors**

- To erase one digit, press  [Clear] once.
- To erase all digits, press and hold down  [Clear] until all digits are erased.

## **Redialing the Last Telephone Number Dialed**

1. Pick up the handset or press  [Speaker] (listening only). The SX6P is now “off-hook.”
2. Press  [Redial].

## **Receiving Calls**

When there is an incoming call, the SX6P rings, an incoming call notification displays the call type and Caller ID information (if available).

### **To answer an incoming call:**

- Pick up the handset and begin talking.  
– or –  
Press  [Speaker] (listening only).

## **Receiving a Call When Caller ID Is Activated**

The Caller ID feature displays the caller’s number when the SX6P rings. If the caller’s name and number are stored together in the SX6P phone book, the caller’s name and number will be displayed. Contact your service provider to activate this feature.



<b>Note:</b>	If there are missed calls (calls not answered), <b>MISSED CALLS</b> will be displayed with the number of calls missed. See the Call History section of this manual on page 12 for more information.
--------------	---

## **Ending Calls**



- To end a call, hang up the phone by placing the handset back onto the SX6P cradle.  
– or –  
Press the speaker key again to end the call (if the phone is in listening only mode).

## **In-Call Functions**

### **Muting a Call**

1. During a call, press  [Mute]. A notification will display in the upper right corner of the LCD screen.
2. Press  [Mute] again to un-mute the microphone.

### **Using Call Waiting**

- To answer an incoming call while you’re on another call, press  [Flash]. Press  [Flash] again to switch between calls. Contact your service provider regarding the availability of the call waiting feature.



## Placing a Call on Hold

1. During a call, press **II** [Hold]. (A notification will display in the upper right corner of the LCD display.)
2. To reactivate the call, press **II** [Hold] again.

## 3-Way Calling

Contact your service provider regarding the availability of 3-way calling.

To perform a 3-way call:

1. Place the first call and wait until it connects.
2. After the first call is connected, dial the second number.
3. Press **⚡** [Flash]. This connects the second call and puts the first call on hold.
4. Wait for the second call to connect.
5. After you are connected to the second call, press **⚡** [Flash], which then connects the first call and completes the 3-way call.

## Adjusting the Handset or Speaker Volume

- During a call, press the up/down arrows to raise ( **▲** ) or lower ( **▼** ) the handset/speaker volume.

**Reminder:** The Speaker is a "listen-only" feature; you must use the handset to speak with your callers.

## Voicemail Access

Contact your service provider regarding the availability of voicemail.













1. Press **✉** [Message].
2. Select **1: Voice Mail**.
3. To listen to your voicemail, select **1: Listen**.
4. If you have deleted all your messages and the message indicator does not go away after an hour, press **2: Clr Msg Ind**.

## Reading Text (SMS) Messages



When you receive a new text message, the envelope icon will appear on the display. To access messages:

1. Press **✉** [Message].
2. Select **2: Read Msgs**.
3. Use the up/down arrows ( **▲ / ▼** ) to select the desired message. Press **☐** [Store] to read it.
4. Once you have read the message, you can do the following:
  - 1: Delete**
  - 2: Forward**
  - 3: Reply**
    - ⚡ [Flash]: Call: dials the callback number in the message (if available)

## Sending a Text Message

1. Press  [Message].
2. Select **3: Create Message**.
3. Select **1: New Message** or **2: Sent Messages**.
4. Select **1: From Phonebook** or **2: Enter Number**.  
(If you select **From Phonebook**, your phone book entries will be displayed alphabetically. Select an entry and press  [Store] to initiate a message to that number.)  
(If you select **Enter Number**, use your keypad to enter a number and press  to continue.)
5. Type the message using the keypad. Press  [Store] when you are finished writing the message.  
To erase one character, press  [Clear] once; to erase the entire screen, press and hold .  
# and down arrow (  ): move forward one character.  
\* and up arrow (  ): move backward one character.  
**MSG** key: switch between uppercase, lowercase, and special characters.
6. Enter the callback number that you want included with the message and press  [Store].  
If you do not want a callback number, press  [Store].
7. Select the message priority as **Normal** or **Urgent**, then press  [Store].
8. Select **Send & Save**, then press  [Store] if you want to send the message immediately and save a copy to the Sent Messages folder.  
– or –  
Select **Send**, then press  [Store] if you want to send the message immediately without saving a copy.



## Deleting All Text Messages

1. Press  [Message].
2. Select **4: Delete Msgs**.
3. Use the up and down arrows to select whether you would like to delete all messages, then press  [Store].

**Note:** Individual messages can be deleted from the **Read Msgs** option.



## Using Message Lock

Message Lock adds password protection to the voicemail/SMS menu. If the message lock is active and you press  [Message] from the idle screen, the unit will prompt you for a password (which is your lock code; the default is 0000).

1. Press  [Message].
2. Select **5: Message Option**.
3. Select **1: Message Lock**.
4. Select the desired option using the up/down arrows and press  [Store] to save.

## Activating Message Alert

Message Alert turns on and off the message alert tone. When off, the envelope icon will still be displayed on the LCD but there is no alert tone.

1. Press  [Message].
2. Select **5: Message Option**.
3. Select **2: Message Alert**.
4. Select the desired option using the up/down arrows and press  [Store] to save.

## Phone Book

The SX6P can be programmed to store frequently called numbers via an electronic phone book. The SX6P phone book can hold up to 99 entries.

### Speed Dialing by Location



To speed dial a phone book entry:

- **For entries 1-9** – Lift the handset and hold down the location number until it dials.
- **For entries 10-99** – Lift the handset, press the first digit and then hold down the 2nd digit until it dials.







### Searching the Phone Book and Dialing a Phone Book Entry

1. Press  [Menu] to access the main menu.
2. Select **1: Phonebook**.
3. Select **1: View**.



There are two options for browsing the electronic phone book:

1. **Name** - View all entries sorted alphabetically. To narrow your search, use your keypad to enter the first letter of the entry you're looking for (for example, press **5** once to display the "J" listings; press **5** three times to display the "L" listings).
  2. **Location** - View all entries sorted by their 2-digit location 01 through 99.
- To dial the selected entry, press  [Flash]. Then pick up the handset if desired. (You can also press  [Store] to view the selected entry's phone number.)

### Adding a New Phone Book Entry

1. Enter the phone number to be stored.
2. Press  [Store].
3. Enter the name to be stored, then press  [Store] again.
  - To enter a letter, press the phone button with that letter on it, pressing it multiple times to cycle through the available letters. (Press  [Clear] to erase a character; press and hold  to erase an entire entry.)
  - \* **key** = backspace
  - # **key** = space
  -  **[Message]** = shift between UPPERCASE and lowercase letters and special characters
  -  **[Clear]** = press once to erase a character; press and hold to erase an entire entry
4. When the unit displays, "**Location auto=XX**", press  [Store] to save the entry.

– or –

Use your keypad or the up/down arrows (  /  ) to select the desired location number, then press  [Store] to save the entry.

**Note:** You can also add an entry to the phone book through the **Phonebook Add** option: (MENU > 1: Phonebook > 2: Add).

## Editing a Phone Book Entry

1. Press  [Menu] to access the main menu.
2. Select **1: Phone Book**.
3. Select **3: Edit**.

There are two options to locate an entry for editing:

1. **Name** - View all entries sorted alphabetically. To narrow your search, use your keypad to enter the first letter of the entry you're looking for (for example, press **5** once to display the "J" listings; press **5** three times to display the "L" listings).
2. **Location** - View all entries sorted by their two-digit location 01 through 99.

## Erasing a Phone Book Entry

1. Press  [Menu] to access the main menu.
2. Select **1: Phonebook**.
3. Select **4: Erase**.





There are two options for locating an entry to erase:

1. **Name** - View all entries sorted alphabetically. To narrow your search, use your keypad to enter the first letter of the entry you're looking for (for example, press **5** once to display the "J" listings; press **5** three times to display the "L" listings).
2. **Location** - View all entries sorted by their two-digit location 01 through 99.





## Call History

The SX6P saves a log of the last 10 missed, outgoing, and incoming calls.





### Viewing Missed Calls

1. Press  [Menu] to access the main menu.
2. Select **2: Call History**.
3. Select **1: Missed**.
4. Use the up/down arrows (  /  ) to select the desired call and press  [Store] to view it.
  - To dial the selected entry, press  [Flash]. Then pick up the handset if desired.

### Viewing Outgoing Calls

1. Press  [Menu] to access the main menu.
2. Select **2: Call History**.
3. Select **2: Outgoing**.
4. Use the up/down arrows (  /  ) to select the desired call and press  [Store] to view it.
  - To dial the selected entry, press  [Flash]. Then pick up the handset if desired.

### Viewing Incoming Calls

1. Press  [Menu] to access the main menu.
2. Select **2: Call History**.
3. Select **3: Incoming**.
4. Use the up/down arrows (  /  ) to select the desired call and press  [Store] to view it.
  - To dial the selected entry, press  [Flash]. Then pick up the handset if desired.

### Erasing All Call History

1. Press  [Menu] to access the main menu.
2. Select **2: Call History**.

3. Select **4: Erase History** and use the up arrow (▲) to select **Erase**.
4. Press  [Store] to erase the Call History.

## Viewing Last Call Time

To display the duration of the previous call:

1. Press  [Menu] to access the main menu.
2. Select **2: Call History**.
3. Select **5: Last Call Time**.

## Viewing Total Air Time

To display the total air time used by the phone since its memory was last cleared:

1. Press  [Menu] to access the main menu.
2. Select **2: Call History**.
3. Select **6: Air Time**.

**Note:** The airtime displayed is based on a calculation performed by the phone; your actual airtime as determined by the network may vary.

## Clearing Air Time

To clear the phone's airtime memory and reset it to zero:

1. Press  [Menu] to access the main menu.
2. Select **2: Call History**.
3. Select **7: Clear Air Tim**.

## Time / Alarm

### Alarm

The SX6P allows you to set an alarm clock that can be used one time or for every day.

1. Press  [Menu] to access the main menu.
2. Select **3: Time / Alarm**.
3. Select **1: Alarm**.

### Time Format

To select a time format for your SX6P (12-hour or 24-hour):

1. Press  [Menu] to access the main menu.
2. Select **3: Time / Alarm**.
3. Select **2: Time Format**.

**Note:** The current time is set by the network; you cannot set the time on the phone. You may elect not to display the time and date.

### Date Format



To select a date format (MM/DD or DD/MM):

1. Press  [Menu] to access the main menu.
2. Select **3: Time / Alarm**.
3. Select **3: Date Format**.



## **Ring / Alert**

The SX6P is capable of supporting multiple ring tones and types of alerts. To adjust these settings, follow these instructions.

### **Ring Tone**



1. Press  [Menu] to access the main menu.
2. Select **4: Ring/Alert**.
3. Select **1: Ring Tone**.
4. Use the up/down arrows ( ▲ / ▼ ) to select the desired ring tone and press  [Store] to save.

### **Ring Volume**

1. Press  [Menu] to access the main menu.
2. Select **4: Ring/Alert**.
3. Select **2: Ring Volume**.
4. Use the up/down arrows ( ▲ / ▼ ) to select a setting and press  [Store] to save.



### **One Minute Alert**

The one-minute alert beep alerts the user after every minute during a call.

1. Press  [Menu] to access the main menu.
2. Select **4: Ring/Alert**.
3. Select **3: 1 Min Alert**.
4. Use the up/down arrows ( ▲ / ▼ ) to select **ON** or **OFF** and press  [Store].



### **Service Alert**

The Service Alert is an alert that sounds when entering or leaving a service area.

1. Press  [Menu] to access the main menu.
2. Select **4: Ring / Alert**.
3. Select **4: Service Alert**.
4. Use the up/down arrows ( ▲ / ▼ ) to select the desired option and press  [Store] to save your setting.

### **Alarm Tone**

The alarm tone is the sound that the alarm clock makes when it rings.



1. Press  [Menu] to access the main menu.
2. Select **4: Ring / Alert**.
3. Select **5: Alarm Tone**.
4. Use the up/down arrows ( ▲ / ▼ ) to select the desired ring tone and press  [Store] to save your setting.

## **Phone Settings**



### **Banner**

The banner is the text displayed on the screen when the phone is not in use. This can be used to personalize your phone.

To set your phone's banner display:



1. Press  [Menu] to access the main menu.
2. Select **5: Phone Settings**.
3. Select **1: Banner**.
4. Use your keypad to enter your desired banner and press  [Store] to save.

### **LCD Contrast**

1. Press  [Menu] to access the main menu.
2. Select **5: Phone Settings**.
3. Select **2: LCD Contrast**.
4. Select the desired setting and press  [Store] to save.



### **DTMF Length**

Some applications may require changing the DTMF (Dual Tone Multi-Frequency) tone length.

1. Press  [Menu] to access the main menu.
2. Select **5: Phone Settings**.
3. Select **3: DTMF Length**.
4. Select the desired option and press  [Store] to save.



### **Key Volume**

The key volume is the loudness of the tones generated when you press the phone's keys.

1. Press  [Menu] to access the main menu.
2. Select **5: Phone Settings**.
3. Select **4: Key Volume**.
4. Select the desired setting and press  [Store] to save.



### **Auto Send Time**

The auto send time is the amount of time the unit waits after you have stopped entering digits before dialing the number.

1. Press  [Menu] to access the main menu.
2. Select **5: Phone Settings**.
3. Select **5: Auto Send Time**.
4. Enter the desired setting and press  [Store] to save.



### **Frequently Dialed Number**

If you dial a phone number twice and stay connected for at least 15 seconds, the unit will remember that phone number and automatically send it without delay. This feature may be enabled or disabled.

1. Press  [Menu] to access the main menu.
2. Select **5: Phone Settings**.
3. Select **6: Freq Dial Number**.
4. Select the desired setting and press  [Store] to save.

## Change Language Displayed On LCD



The SX6P is capable of displaying multiple languages on the LCD screen.

1. Press  [Menu] to access the main menu.
2. Select **5: Phone Settings**.
3. Select **7: Language**.
4. Select the desired setting and press  [Store] to save.

## Dial Tone Type

Your SX6P can produce the corresponding dial tones for phone systems in several countries.



To select a regional dial tone type:

1. Press  [Menu] to access the main menu.
2. Select **5: Phone Settings**.
3. Select **8: Dial Tone Type**.
4. Select the desired setting and press  [Store] to save.
  1. North America (low 350 Hz, high 440 Hz)
  2. Latin America (low 425 Hz, high 425 Hz)
  3. East Europe (low 425 Hz, high 425 Hz)
  4. China (low 450 Hz, high 450 Hz)
  5. Nicaragua (low 450 Hz, high 450 Hz)
  6. India (low 375.5 Hz, high 412.5 Hz)

## Self Test Cycle

The unit will perform a periodic self test to ensure the proper operation of the phone. The default setting is 180 minutes (3 hours).

To set the self test cycle interval:

1. Press  [Menu] to access the main menu.
2. Select **5: Phone Settings**.
3. Select **9: Selftest Cycle**.
4. Select between 0 (disables self test) and 65535 minutes and press  [Store] to save.

## Phone Info

### My Phone # (display only)

1. Press  [Menu] to access the main menu.
2. Select **6: Phone Info**.
3. Select **1: My Phone #**.

### Software Version Information

1. Press  [Menu] to access the main menu.
2. Select **6: Phone Info**.
3. Select **2: Version**.

### Tech Mode

1. Press  [Menu] to access the main menu.
2. Select **6: Phone Info**.
3. Select **3: Tech Mode**.





## **Security**

### **Change Code**



The lock code is a 4-digit password used to prevent unauthorized access to the phone. This setting allows you to change your phone's lock code. The default lock code is **0000**.

**Note:** The phone's default lock code is **0000**.

**To change your phone's lock code:**

1. Press  [Menu] to access the main menu.
2. Select **7: Security**.
3. Enter the current lock code. (The default lock code is 0000.)
4. Select **1: Change Code**.
5. Enter your new lock code and press  [Store] to save the new setting.



### **Restrict Outgoing Calls**

1. Press  [Menu] to access the main menu.
2. Select **7: Security**.
3. Enter the current lock code.
4. Select **2: Restrict**.
5. Select the desired option and press  [Store] to save.

### **Voice Privacy**



The cellular CDMA network offers inherent voice privacy. Check with your service provider for the availability of enhanced voice privacy mode. If Enhanced is selected, the phone will request Enhanced Voice Privacy and a "P" will be shown on the display (if Enhanced Voice Privacy has been granted by the network).

**To set your Voice Privacy level:**

1. Press  [Menu] to access the main menu.
2. Select **7: Security**.
3. Enter the current lock code.
4. Select **3: Voice Privacy**.
5. Select the desired option and press  [Store] to save.



### **Lock Mode**

The Lock Mode setting determines whether the phone will automatically lock. If Lock Mode is enabled, you are required to enter your lock code before being able to access the phone.



1. Press  [Menu] to access the main menu.
2. Select **7: Security**.
3. Enter the current lock code.
4. Select **4: Lock Mode**.
5. Select the desired option and press  [Store] to save.

## Reset Phone

This setting is used to reset the SX6P's settings to the user default values.

1. Press  [Menu] to access the main menu.
2. Select **7: Security**.
3. Enter the current lock code.
4. Select **5: Reset Phone**.
5. Select **RESET** and press  [Store] to save.



## Hotline

1. Press  [Menu] to access the main menu.
2. Select **7: Security**.
3. Enter the current lock code.
4. Select **6: Hot Line**.
5. Select **Enable** (followed by phone number to dial automatically) or **Disable** and press  [Store].

## RUIM CHV1 (RUIM Models Only)

If your SX6P requires an RUIM, this setting allows you to enable, disable, or change its PIN (Personal Identification Number, also called the CHV1 [Card Holder Verification 1]).



This menu option is not available if your SX6P is bonded to a RUIM.

1. Press  [Menu] to access the main menu.
2. Select **7: Security**.
3. Enter the current lock code.
4. Select **7: RUIM CHV1**.
5. Select the desired option and press  [Store].
6. Enter the SX6P's PIN.
7. If you are changing the PIN, enter the new PIN.

## Programming

If your phone number has not been programmed into your SX6P, the programming menu allows you to enter your phone number, or MIN (Mobile Identification Number), into the phone.

**To program your phone number into your SX6P:**

1. Press  [Menu] to access the main menu.
2. Select **8: Programming**.
3. Enter the current lock code.
4. Enter the phone number (or MIN) and press  [Store].

## **BONDING AN SX6P TO A RUIIM**

You can bond an SX6P to the RUIIM that is inserted in it. Once an SX6P has been bonded to a RUIIM, the SX6P will not operate normally with any other RUIIM installed in it. It will reject incoming calls and permit only emergency outgoing calls. The same holds true for any other SX6P the bonded RUIIM is installed into; it will not operate normally.

Bonding an SX6P to a RUIIM can only be done once. It cannot be undone by the user.

Before you can bond the SX6P to a RUIIM, the RUIIM must have a PIN enabled. See **Security** (page 17) for details.

1. Press  [Menu] to access the main menu.
2. Select **6: Phone Info**.
3. Select **3: Tech Mode**.
4. Enter your Tech User Password.
5. Select **8: Bonding PIN**.
6. Enter the inserted RUIIM's PIN.
7. Cycle your SX6P's power. After the unit reboots, it will be bonded to the RUIIM.

## **SX6P Troubleshooting**

### **Telephone Service is Not Working (Cannot place or receive calls)**

- Make sure the SX6P powered on properly.
- Make sure any equipment that is externally connected to the SX6P is correctly connected.
- Test any externally connected equipment on a known system to verify operation.
- Make sure the antenna is properly connected.
- Make sure your wireless account is activated and service is established.

### **Unable to Receive Calls**

- Is the handset on the cradle? If not, place the handset on the cradle and try again.
- Is the SX6P making a loud repetitive tone (ROH - Receiver Off-Hook)? If so, either the speaker or the handset is off-hook. Hang up and try again.

### **Unable to Place Calls**

- If you do not hear a standard dial tone when the phone is off-hook, then there may be a problem with your service. Contact your service provider if you think the issue is service-related.

### **Moisture or Ventilation Problems**

- Is moisture forming on or around the SX6? Remove any moisture with a clean dry towel and move the unit to a well ventilated area. Review the Temperature and Environment section of this manual (page 21) for more information.

### **No Power**

- Is the power supply connected to the unit? Make sure power is available and that the power supply is properly connected to the SX6P.
- The power supply is connected but the unit still has no power. Make sure the circuit is functioning to the power supply. Check breakers and contact your power company. The power may be off at your location.

## **Conformance Statements**

### **FCC Part 15 Class B Compliance**

This Phonecell® SX6P model has been tested and found to comply with the limits for a Class B digital device, pursuant to Part 15 of the FCC rules. Changes or modifications not expressly approved by Telular Corporation will void your authority to operate the equipment per FCC part 15 paragraph 15.21. These limits are designed to provide reasonable protection against harmful interference in a residential installation. This equipment generates, uses and can radiate radio frequency energy and, if not installed and used in accordance with the instructions, may cause harmful interference to radio communications. However, there is no guarantee that interference will not occur in a particular installation. If this equipment does cause harmful interference to radio or television reception, which can be determined by turning the equipment OFF and ON, the user is encouraged to try to correct the interference by one or more of the following measures:

- Reorient or relocate the antenna.
- Increase the separation between the equipment and the terminal.
- Connect the equipment into an outlet on a circuit different from that to which the terminal is connected.
- Consult your Authorized Telular Distributor or an experienced radio/TV technician for help.

## **Safety Information**

The Phonecell® SX6P functions as both a radio transmitter and receiver. When it is ON, the SX6P receives and sends out radio frequency (RF) energy. The SX6P CDMA unit operates in the frequency ranges of 824 MHz to 894 MHz and / or 1850 MHz to 1910 MHz. When you use the SX6P, the cellular system handling your call controls the power level at which the unit transmits.

### **Exposure to RF (Radio Frequency) Energy**

In 1991, the Institute of Electrical and Electronics Engineers (IEEE), and in 1992, the American National Standards Institute (ANSI), updated the 1982 ANSI Standard for safety levels with respect to human exposure to RF energy. After reviewing the available body of research, more than 120 scientists, engineers and physicians from universities, government health agencies and industry developed this updated Standard. In March, 1993, the U.S. Federal Communications Commission (FCC) proposed the adoption of this updated Standard.

The design of your Telular Phonecell® SX6P complies with this updated Standard. Of course, if you want to limit RF exposure even further than the updated ANSI Standard, you may choose to control the duration of your calls and operate your phone in the most power-efficient manner.

### **Safe Operation Requirement**

The Phonecell® SX6P must be either wall mounted or desk mounted and should not be operated when any person is within 203 mm (8 inches) of the antenna.

### **Temperature and Environment**

**Operating Temperature:** From -10°C to +50°C ; Up to 95% relative humidity (non-condensing).

**Storage Temperature:** From -40°C to +60°C; Up to 95% relative humidity (non-condensing).

### **Antenna Care and Replacement**

Do not use the Phonecell® SX6P with a damaged antenna. If a damaged antenna comes into contact with the skin, a minor burn may result. Have your antenna replaced by a qualified technician immediately. Use only a manufacturer-approved antenna. Unauthorized antennas, modifications, or attachments could damage the Phonecell® SX6P.

## **Driving**

Check the laws and regulations on the use of cellular products in the areas where you drive. Some jurisdictions prohibit your using a cellular device while driving a vehicle. Even if your jurisdiction does not have such a law, we strongly suggest that, for safety reasons, the driver use extreme caution when operating the cellular device while the vehicle is in motion. Always obey the law.

## **Electronic Devices**

Most modern electronic equipment is shielded from RF energy. However, RF energy from cellular devices may affect inadequately shielded electronic equipment.

RF energy may affect improperly installed or inadequately shielded electronic operating and entertainment systems in motor vehicles. Check with the manufacturer or its representative to determine if these systems are adequately shielded from external RF energy. You should also check with the manufacturer of any equipment that has been added to your vehicle.

Consult the manufacturer of any personal medical devices (such as pacemakers, hearing aids, etc.) to determine if they are adequately shielded from external RF energy.

Turn your Phonecell® SX6P OFF in health care facilities when any regulations posted in the areas instruct you to do so. Hospitals or health care facilities may be using equipment that could be sensitive to external RF energy.

## **Aircraft**

Turn OFF your Phonecell® SX6P before boarding any aircraft.

- Use it on the ground only with crew permission.
- Do not use it in the air.

To prevent possible interference with aircraft systems, U.S. Federal Aviation Administration (FAA) regulations require you to have permission from a crew member to use your cellular phone (or any other cellular product) while the plane is on the ground. To prevent interference with aircraft systems, FCC regulations prohibit using your cellular device while the plane is in the air.

## **Children**

Do not allow children to play with your Phonecell® SX6P to prevent damage to the unit.

## **Blasting Areas**

Construction crews often use remote control RF devices to set off explosives. Therefore, to avoid interfering with blasting operations, turn your Phonecell® SX6P OFF when in a "blasting area" or in areas posted: "Turn off two-way radio."

## **Potentially Explosive Atmospheres**

Turn your Phonecell® SX6P OFF when in any area with a potentially explosive atmosphere. It is rare, but your Phonecell® SX6P or its accessories could generate sparks. Sparks in such areas could cause an explosion or fire resulting in bodily injury or even death.

Areas with a potentially explosive atmosphere are often, but not always, clearly marked. They include fueling areas such as gas stations; below deck on boats; fuel or chemical transfer or storage facilities; areas where the air contains chemicals or particles, such as grain, dust, or metal powders; and any other area where you would normally be advised to turn off your vehicle engine.

Do not transport or store flammable gas, liquid or explosives in the area of your Phonecell® SX6P or accessories.

Vehicles using liquefied petroleum gas (such as propane or butane) must comply with the National Fire Protection Standard (FPA-58). For a copy of this standard, contact the National Fire Protection Association, One Batterymarch Park, Quincy, MA 02269, Attn: Publications Sales Division.

**Patents:**

Telular Corporation products are protected and manufactured under one or more of the following U.S. patents and related international patents and patents pending relating thereto: 4,658,096; 4,737,975; 4,775,997; 4,868,519; 4,922,517; 5,134,651; 5,361,297; 5,469,494; 5,046,085; 5,715,296.

**Trademarks:**

Telular Corporation owns the following registered trademarks: TELULAR and design, TELULAR, CELJACK, MAXJACK, TELCEL, HEXAGON LOGO, PHONECELL, CELSERV, TELGUARD, CPX, and AXCELL.

"Licensed by QUALCOMM Incorporated under one or more of the following Patents:

4,901,307	5,490,165	5,056,109	5,504,773	5,101,501	5,778,338
5,506,865	5,109,390	5,511,073	5,228,054	5,535,239	5,710,784
5,267,261	5,544,196	5,267,262	5,568,483	5,337,338	5,659,569
5,600,754	5,414,796	5,657,420	5,416,797	6,775,522	6,785,517



647 North Lakeview Parkway  
Vernon Hills, Illinois 60061, USA  
Tel: 847-247-9400 • Fax: 847-247-0021  
E-mail: [support@telular.com](mailto:support@telular.com)  
<http://www.telular.com>