

TEMPRIS User Manual

TEMPRIS LAB and TEMPRIS PRO Temperature Measurement Systems
TEMPRIS DataServer Version 7.0 User Guide

TEMPRIS User Manual

TEMPRIS LAB and TEMPRIS PRO Temperature Measurement Systems
TEMPRIS DataServer Version 7.0 User Guide

Document Version: 7.0.009

Last printing: October 2012

Published by: iQ-mobil solutions GmbH, Holzkirchen, Germany

The information contained in this documentation as well as the products and/or programs described therein are subject to change without notice and should not be construed as a commitment by iQ-mobil solutions GmbH.

Although iQ-mobil have gone to great effort to verify the integrity of the information provided with the TEMPRIS documentation, this documentation could contain technical inaccuracies or typographical errors. iQ-mobil shall not be liable for errors contained therein or for incidental consequential damages in connection with the furnishing, performance or use of this material. iQ-mobil appreciate readers' and/or users' comments in order to improve this documentation and/or the products described therein. Changes are periodically made to the information therein. These changes will be incorporated in new editions of the TEMPRIS documentation.

All rights reserved. No part of the TEMPRIS documentation may be reproduced, stored in a retrieval system, translated, transcribed or transmitted, in any form or by any means manual, electric, electronic, electromagnetic, mechanical, chemical, optical or otherwise without prior express written permission from iQ-mobil solutions GmbH.

TEMPRIS® is a registered trademark of iQ-mobil solutions GmbH. TEMPRIS DataServer™ is a trademark of iQ-mobil solutions GmbH. All other products or services mentioned in this publication are identified by the trademarks or service marks of their respective companies or organizations.

Copyright © 2009-2012 iQ-mobil solutions GmbH.
All Rights Reserved.

Contents

1	Important Information	7
1.1	Using this Documentation	7
	Compilation and Publication Notice	7
	Organization of this Documentation	7
	Illustrations	8
	Copyright	8
	Trademarks	8
1.2	Symbols and Conventions	9
	Terms and Notations	9
	Acronyms	9
	Symbolic Conventions	10
	Safety Symbols	11
1.3	Intended Use	12
1.4	Operators and Users	12
1.5	Operator Obligations	12
1.6	User Obligations	12
1.7	Safety Instructions	13
	1.7.1 Important Safety Instructions	13
	1.7.2 CE Compliance	15
	1.7.3 United States FCC Compliance	16
	1.7.4 Industry Canada (IC) Compliance	17
1.8	Related Documentation	18
1.9	Addresses	18
2	Introduction	19
2.1	TEMPRIS - Wireless Temperature Monitoring without Batteries	19
2.2	TEMPRIS Operational Principle	20
2.3	TEMPRIS Applications	21
3	TEMPRIS System Setup	23
3.1	TEMPRIS System Components	23
3.2	Required Cable Connections	25
	3.2.1 TEMPRIS PRO Connections and Interfaces	25
	3.2.2 TEMPRIS LAB Connections and Interfaces	28
3.3	TEMPRIS DataServer Installation	31
	3.3.1 TEMPRIS DataServer System Requirements	31
	3.3.2 New Installation	32
	3.3.3 Update Installation	32
4	TEMPRIS DataServer User Interface and Function Reference	33
4.1	TEMPRIS DataServer Features	34
4.2	Program Start	35
	4.2.1 TEMPRIS LAB Start-up Screen	35
	4.2.2 TEMPRIS PRO Start-up Screen	36
4.3	Status Bar	37
4.4	Interface Configuration	38
4.5	Establishing the Data Connection between PC and TEMPRIS Interrogation Unit	39
4.6	Config View	41
	4.6.1 Config View - General	42
	4.6.2 Config View - Channel / Antenna Configuration	45
	4.6.3 Config View - Measurement	51
4.7	Text View	52
4.8	Graphics View	55
4.9	Signal View	65
4.10	Clearing the Current Data Screen	67
4.11	Recording Incoming Measuring Data onto Log Files	67
4.12	Print and Plot Output	70
4.13	Loading Log Files for Offline Data Visualization	71
4.14	Data Export to CSV	73
4.15	Copying Screens to the Windows Clipboard	75
4.16	Retrieving the Current Configuration Settings	76
4.17	Exiting the TEMPRIS DataServer	76

5 TEMPRIS Options..... 77
5.1 Modbus TCP/IP Interface.....77
5.1.1 TEMPRIS Modbus TCP/IP Interface Setup78
5.1.2 TEMPRIS Modbus TCP/IP Channel Configuration.....79

Tables

Table 3-1: TEMPRIS DataServer System Requirements.....31
Table 4-1: TEMPRIS DataServer Status Bar Elements.....37

Figures

Figure 3-1: TEMPRIS Configuration with Single Antenna23
Figure 3-2: TEMPRIS Configuration with Multiple Antennas24
Figure 3-3: TEMPRIS PRO Connections with Labels.....25
Figure 3-4: TEMPRIS PRO Antenna Connection A126
Figure 3-5: Torque Wrench26
Figure 3-6: TEMPRIS PRO Antenna Multiplexer Connection X.....27
Figure 3-7: TEMPRIS LAB Connections and Interfaces28
Figure 3-8: TEMPRIS LAB Antenna Connection A129
Figure 3-9: TEMPRIS LAB Virtual Keyboard29
Figure 4-1: TEMPRIS LAB Start-up Screen35
Figure 4-2: TEMPRIS PRO Start-up Screen36
Figure 4-3: TDS Status Bar Elements37
Figure 4-4: TDS Options - Connection38
Figure 4-5: TDS Toolbar - Stop Logging.....39
Figure 4-6: TDS Toolbar - Stop Measure39
Figure 4-7: TDS File - Connect Submenu.....39
Figure 4-8: TDS Status Bar - Connect Indicators40
Figure 4-9: TDS Status Bar - Receive Data Indicators40
Figure 4-10: TDS Config View41
Figure 4-11: TDS Config View - General42
Figure 4-12: TDS Config View - General - Select Config43
Figure 4-13: TDS Config View - General - Save Config44
Figure 4-14: TDS Config View - Channel / Antenna Configuration45
Figure 4-15: TDS Config View - Channel / Antenna Configuration - Active Channels45
Figure 4-16: TDS Config View - Channel / Antenna Configuration - Channel Setup46
Figure 4-17: TDS Config View - Channel / Antenna Configuration - Channel Tooltips47
Figure 4-18: TDS Config View - Channel / Antenna Configuration - Channel Settings48
Figure 4-19: TDS Config View - Channel / Antenna Configuration - Change Sensor49
Figure 4-20: TDS Config View - Channel / Antenna Configuration - Channel Properties50
Figure 4-21: TDS Config View - Measurement51
Figure 4-22: TDS Text View52
Figure 4-23: TDS Text View - Fahrenheit Temperature Display54
Figure 4-24: TDS Graphics View55
Figure 4-25: TDS Graphics View - Channel Toolbar.....56
Figure 4-26: TDS Graphics View - Channel Buttons56
Figure 4-27: TDS Graphics View - Channel Button Context Menu.....56
Figure 4-28: TDS Graphics View - Channel Display Settings.....57
Figure 4-29: TDS Graphics View - Show All Data58
Figure 4-30: TDS Graphics View - Marker Function59
Figure 4-31: TDS Graphics View - Zoom Window Selection60
Figure 4-32: TDS Graphics View - Zoom Window Display60
Figure 4-33: TDS Graphics View - Time Label Settings.....61
Figure 4-34: TDS Graphics View - Temperature Label Settings.....62
Figure 4-35: TDS Graphics View - Graphics Area Context Menu.....63
Figure 4-36: TDS Graphics View - Show Second Trace S/N.....64
Figure 4-37: TDS Signal View - Signal Strength65
Figure 4-38: TDS Signal View - Antenna Matching66
Figure 4-39: Start Logging - Log File Name Selection67
Figure 4-40: Start Logging - Log File Info68
Figure 4-41: Save Current Data.....69
Figure 4-42: Print Page Setup70
Figure 4-43: Loaded Log File Info71

Figure 4-44: Loaded Log File Info - Data.....72
Figure 4-45: TEMPRIS CSV Data in Microsoft Excel.....73
Figure 4-46: Copy Screen to Clipboard75
Figure 4-47: Current Configuration Settings.....76
Figure 5-1: TEMPRIS Modbus TCP/IP to PLC Interface Setup77
Figure 5-2: TEMPRIS Sensor Data and Sensor Status Output to PLC.....77
Figure 5-3: TEMPRIS DataServer Config – System – Automation78
Figure 5-4: TEMPRIS DataServer Channel Properties - Automation80

1 Important Information

This documentation is part of the TEMPRIS system. It describes how to use the TEMPRIS system and the TEMPRIS DataServer software. Please read this documentation carefully before using the TEMPRIS system.

The TEMPRIS system may only be used by persons who have been appropriately trained.

1.1 Using this Documentation

Compilation and Publication Notice

This documentation has been compiled and published by iQ-mobil solutions GmbH. It covers the latest product descriptions and technical specifications. iQ-mobil solutions GmbH reserves the right to make changes without notice to this documentation and the specifications of the products described in this documentation. iQ-mobil solutions GmbH shall not be responsible for any damages (including consequential) caused by reliance on the materials presented, including but not limited to typographical and other errors relating to this documentation.

Organization of this Documentation

- [Chapter 1](#) provides important information about this documentation and the products described therein.
- [Chapter 2](#) provides general information about wireless temperature monitoring with TEMPRIS, the TEMPRIS operational principle and TEMPRIS applications.
- [Chapter 3](#) provides details about the interfaces and connections of the TEMPRIS LAB and TEMPRIS PRO systems and contains information about how to set up these systems and how to install the TEMPRIS DataServer software.
- [Chapter 4](#) describes the user interface and the functions of the TEMPRIS DataServer software and provides detailed information about how to use the TEMPRIS DataServer software.
- [Chapter 5](#) describes optional TEMPRIS features and how to use them.

Illustrations

The images used in the TEMPRIS documentation (photos, screenshots, etc.) may differ from the original as long as the correct description of the illustrated functions is not affected.

Copyright

All rights reserved. No part of the TEMPRIS documentation may be reproduced, stored in a retrieval system, translated, transcribed or transmitted, in any form or by any means manual, electric, electronic, electromagnetic, mechanical, chemical, optical or otherwise without prior express written permission from iQ-mobil solutions GmbH.

Trademarks

TEMPRIS® is a registered trademark of iQ-mobil solutions GmbH. TEMPRIS DataServer™ is a trademark of iQ-mobil solutions GmbH. All other products or services mentioned in this publication are identified by the trademarks or service marks of their respective companies or organizations.

1.2 Symbols and Conventions

Terms and Notations

The following terms and notations are used throughout the TEMPRIS documentation:

Menu Bar	Horizontal pull-down menu function bar at the top of the TEMPRIS DataServer screen.
Function Tab	Tab controls under the Menu Bar for switching between different views in the centered of the TEMPRIS DataServer screen.
Status Bar	Horizontal bar with status message and indicator controls at the bottom of the TEMPRIS DataServer screen.
Toolbar	Horizontal bar above the Status Bar with large touch-screen command buttons for frequently used commands and/or functions.
Config View	Center screen area for displaying and setting configuration parameters.
Text View	Center screen area for displaying incoming TEMPRIS measuring data using temperature value text controls.
Graphics View	Center screen area for displaying incoming TEMPRIS measuring data using graphic plots.
Signal View	Center screen area for displaying radio signal quality and antenna assignment information during for the currently connected TEMPRIS system.

Acronyms

The following acronyms are used throughout the TEMPRIS documentation:

TLAB	Type/model name for TEMPRIS LAB, the laboratory version of the TEMPRIS systems.
TIRU	Type/model name for TEMPRIS IRU-2, the TEMPRIS interrogation unit.
IRU	Acronym for I nter R ogation U nit of the TEMPRIS system.
TDS	Acronym for TEMPRIS DataServer, the Windows software for communicating with TEMPRIS interrogation units and for monitoring, logging, archiving and visualizing TEMPRIS measuring data.

Symbolic Conventions

The following symbolic conventions are used throughout the TEMPRIS documentation:

Lineprint	Lineprint font represents text output generated by the system.
Boldface	Boldfaced words or characters in format or command descriptions represent topic definitions or syntactic terminals, i.e., commands or keywords to be inserted directly.
<i>Emphasize</i>	<i>Emphasized</i> text is used for optical accentuation.
" "	Double quotes denote names and/or path names or enclose characters and/or character sequences directly to be inserted.
[]	Square brackets enclose optional items in format or command descriptions or physical unit designators in normal text.
{ }	Braces enclose a list of items in format or command description, from which one has to be chosen.
	A vertical bar separates items in a list of choices.
< >	Angle brackets enclose the logical name of a key on the keyboard. In format or command descriptions, angle brackets enclose values to be supplied.
>	Boldfaced greater signs in line print font are used for denoting prompts on operating system level.
...	Horizontal ellipsis points indicate either optional repetition of the preceding element in format or command descriptions or absence of irrelevant parts of a figure or example.
:	Vertical ellipsis points indicate absence of irrelevant parts of a figure, an example or a format or command description.
a b ...	Keyboard (input) - standard key(s)
F1 F2 ...	Keyboard (input) - function key(s)
filename	File or directory path name.
keyword	Topic definitions or syntactic terminals, i.e., commands or keywords to be inserted directly.
message	TEMPRIS DataServer / system status or error message display.
Menu	TEMPRIS DataServer function menu.
Menu Function	TEMPRIS DataServer menu function.
Menu Option	TEMPRIS DataServer menu option.
Button	TEMPRIS DataServer dialog button.

The character sequences mentioned above may regain original meaning when used in programming languages, interpreter languages, specification languages, syntax description languages, etc.

Safety Symbols

1.3 Intended Use

TEMPRIS is a wireless and battery-free temperature measurement system for measuring the product temperature in pharmaceutical lyophilization processes. TEMPRIS measurement data can be used for lyo-cycle development and optimization, hot and cold spot detection, lyo-cycle scale-up and lyo-cycle transfer.

Notes

Functions or applications not listed in the range are excluded of the intended use. Modifications of the TEMPRIS products which are possible to be done by a skilled person leading to additional or modified functions or applications are excluded of the intended use.

1.4 Operators and Users

The TEMPRIS system may only be installed, operated and used by persons who have the necessary training or knowledge and experience to do so.

TEMPRIS system fittings, extensions, adjustments, modifications or repairs may only be carried out by the manufacturer or personnel authorized by the manufacturer.

The TEMPRIS user should be familiar with the use of his Windows operating system in a network environment. A basic understanding of wireless data transmission technology is beneficial.

1.5 Operator Obligations

The operator of TEMPRIS system is responsible for ensuring that

- national or local regulations for installation, operation, use and maintenance are met,
- the accident prevention regulations are complied with,
- the TEMPRIS system is in a proper and safe condition,
- the TEMPRIS documentation required for the operation of the system is readily accessible at all times.

1.6 User Obligations

When entering parameters, note the following:

- The input parameters must be verified by the user, i.e., the user must verify the correctness of the entered values.
- If during this test deviations between the desired and/or required values and values displayed on the unit can be found, then the setting must be corrected before the function is activated.
- The actual values must be compared with predetermined target values.

1.7 Safety Instructions

1.7.1 Important Safety Instructions

- Read these instructions.
- Keep these instructions.
- Heed all warnings.
- Follow all instructions.
- The TEMPRIS system must be installed by iQ-mobil solutions GmbH. The TEMPRIS system installation must be formally accepted by the customer.
- Formally accepted TEMPRIS installations must not be modified by the customer.
- Do not use the TEMPRIS system if the security is no longer guaranteed due to damage.
- Do not use the TEMPRIS system near water or if any of its components are damp or wet.
- The TEMPRIS system cables must be wired in such a way as to avoid any safety hazards. Legally required workplace precautions must be followed.
- Do not touch the power cable of the TEMPRIS system with damp or wet hands.
- Do not block any ventilation openings or cooling fins of any of the TEMPRIS components. The installation and fitting instructions must be followed.
- The operating temperature for the TIRU, TLAB, HF-MUX and Outbox components ranges from 0 °C to +35 °C. Do not install or place these components near any heat sources such as radiators, heat registers, stoves, or apparatus that produce heat. Protect these components from direct sunlight.
- Only use attachments/accessories specified by iQ-mobil solutions GmbH.
- Uninterrupted Power Systems (UPS) are recommended if TEMPRIS is used in productive environments.
- All TEMPRIS components except for TIRU, TLAB and HF-MUX must be cleaned and sterilized before being used in a productive lyophilization system (appropriate procedures: steam sterilization up to 135 °C, 1% ETO solution).
- TEMPRIS temperature sensors must be replaced after a maximum of 20 sterilization cycles.
- Refer all servicing to qualified service personnel authorized by iQ-mobil solutions GmbH. Servicing is required when the apparatus has been damaged in any way, such as power-supply cord or plug is damaged, liquid has been spilled or objects have fallen into the apparatus, the apparatus has been exposed to rain or moisture, does not operate normally, or has been dropped.

Power Source Warning

Labels on the TEMPRIS components indicate the correct power source. Operate the components only from electrical outlets with the voltage and frequency indicated on the labels. If you are uncertain of the type of your power supply, consult your service provider or your local power company.

The AC inlets on the TEMPRIS unit must remain accessible and operable at all times.

Commissioning Requirements

The TEMPRIS system must be in perfect condition. The TEMPRIS system must not be put in operation if any of its components are mechanically damaged. Damaged components must be replaced.

Repair

The installation of the TEMPRIS system and extensions, adjustments, alterations or repairs to the TEMPRIS system may only be performed by the manufacturer or persons authorized by him.

1.7.2 CE Compliance

Declaration of Conformity with Regard to the EU Directive 1999/5/EC (R&TTE Directive)

This declaration is only valid for configurations (combinations of software, firmware and hardware) supported or provided by iQ-mobil solutions GmbH for use within the EU. The use of software or firmware not supported or provided by iQ-mobil solutions GmbH may result in the equipment no longer being compliant with the regulatory requirements.

Deutsch [German]	Dieses Gerät entspricht den grundlegenden Anforderungen und den weiteren entsprechenden Vorgaben der Richtlinie 1999/5/EU.
English	This equipment is in compliance with the essential requirements and other relevant provisions of Directive 1999/5/EC.

Note: The full declaration of conformity for this product is available from iQ-mobil solutions GmbH.

The following standards were applied during the assessment of the product against the requirements of the Directive 1999/5/EC:

- Radio: ETSI EN 300 328, EN 62311, 1999/519/EC
- EMC: EN 61000-6-2, EN 61000-6-4, EN 301 489-1, EN 301 489-17
- Safety: EN 60950-1

The CE mark and class-2 identifier are affixed to the product and its packaging. This product conforms to the following European directives:



National Restrictions

This product is for indoor use only.

Note: The regulatory limits for maximum output power are specified in EIRP. The EIRP level of a device can be calculated by adding the gain of the antenna used (specified in dBi) to the output power available at the connector (specified in dBm).

Antennas

Use only the antenna(s) supplied with the product.

1.7.3 United States FCC Compliance

FCC Declaration of Conformity

This device complies with Part 15 of the FCC Rules. Operation is subject to the following two conditions: 1) this device may not cause harmful interference, and 2) this device must accept any interference received, including interference that may cause undesired operation.

Caution: Changes or modifications not expressly approved by the party responsible for compliance could void the user's authority to operate the equipment.

Note: This equipment has been tested and found to comply with the limits for a Class A digital device, pursuant to part 15 of the FCC Rules. These limits are designed to provide reasonable protection against harmful interference when the equipment is operated in a commercial environment. This equipment generates, uses, and can radiate radio frequency energy and, if not installed and used in accordance with the instruction manual, may cause harmful interference to radio communications. Operation of this equipment in a residential area is likely to cause harmful interference in which case the user will be required to correct the interference at his own expense.

Note: This equipment complies with FCC radiation exposure limits set forth for an uncontrolled environment. This equipment should be installed and operated with minimum distance 20 cm between the radiator and your body.

This transmitter must not be co-located or operating in conjunction with any other antenna or transmitter.

1.7.4 Industry Canada (IC) Compliance

Industry Canada (IC) Compliance Statement

This device complies with Industry Canada licence-exempt RSS standard(s). Operation is subject to the following two conditions: (1) this device may not cause interference, and (2) this device must accept any interference, including interference that may cause undesired operation of the device.

Under Industry Canada regulations, this radio transmitter may only operate using an antenna of a type and maximum (or lesser) gain approved for the transmitter by Industry Canada. To reduce potential radio interference to other users, the antenna type and its gain should be so chosen that the equivalent isotropically radiated power (e.i.r.p.) is not more than that necessary for successful communication.

Industrie Canada (IC) Déclaration de conformité

Le présent appareil est conforme aux CNR d'Industrie Canada applicables aux appareils radio exempts de licence. L'exploitation est autorisée aux deux conditions suivantes : (1) l'appareil ne doit pas produire de brouillage, et (2) l'utilisateur de l'appareil doit accepter tout brouillage radioélectrique subi, même si le brouillage est susceptible d'en compromettre le fonctionnement.

Conformément à la réglementation d'Industrie Canada, le présent émetteur radio peut fonctionner avec une antenne d'un type et d'un gain maximal (ou inférieur) approuvé pour l'émetteur par Industrie Canada. Dans le but de réduire les risques de brouillage radioélectrique à l'intention des autres utilisateurs, il faut choisir le type d'antenne et son gain de sorte que la puissance isotrope rayonnée équivalente (p.i.r.e.) ne dépasse pas l'intensité nécessaire à l'établissement d'une communication satisfaisante.

Industry Canada (IC) Radiation Exposure Statement

This equipment complies with IC RSS-102 radiation exposure limits set forth for an uncontrolled environment. This equipment should be installed and operated with minimum distance 20cm between the radiator and your body.

Industrie Canada (IC) Déclaration d'exposition aux radiations

Cet équipement est conforme aux limites d'exposition aux rayonnements IC établies pour un environnement non contrôlé. Cet équipement doit être installé et utilisé avec un minimum de 20 cm de distance entre la source de rayonnement et votre corps.

1.8 Related Documentation

As TEMPRIS customer you will receive project-specific TEMPRIS documentation such as specific installation guides and user manuals, SOP's, IQ/OQ documentation, etc. as per your requirements and/or according to agreements with us. Please contact TEMPRIS support if you have any queries in relation to project-specific TEMPRIS documentation. Check the [iQ-mobil Website](http://www.iq-mobil.com) at www.iq-mobil.com for our contact details.

1.9 Addresses

We appreciate comments from the people who are using the TEMPRIS system, and we are particularly thankful for suggestions on how to improve the TEMPRIS system and/or the TEMPRIS DataServer software by introducing new or improving existing features and functions. If you have questions or problems related to the use of TEMPRIS, please contact:

iQ-mobil solutions GmbH

Industriestrasse 7
83607 Holzkirchen
Germany

Phone...: +49-(0)8024-47447 0
Fax: +49-(0)8024-47447 10
E-Mail ..: tempris@iqmobil.com
Web: www.iqmobil.com

2 Introduction

2.1 TEMPRIS - Wireless Temperature Monitoring without Batteries

Temperature is an important physical parameter measured in many scientific and technical fields such as chemistry, pharmacology, medicine, physics, electronics, mechanical engineering, etc. In many cases, it is particularly important to measure and record temperature

- as accurately as possible,
- as genuinely as possible,
- as reproducible as possible,
- as immediate as possible (real-time, online),
- in the widest possible measurement range,
- through long periods of time.

Frequently, these objectives are only partially achieved.

This is due to the use of conventional temperature sensors (thermometer, thermo elements, thermo resistors, etc.), which tend to falsify and delay (sensor response versus time hysteresis) measurement results because of

- the sensor's thermal capacity (thermal mass),
- the electrical energy required for sensor operation,
- heat transmission / thermal conduction through power and/or data cables.

These problems were and still are commonly tackled by either using "local data loggers" or by deploying battery-powered (radio) data transmission facilities to avoid trouble-prone cables. However, these methods cause a significant if not inadmissible thermal capacity increase in the measurement set-up with the aforementioned undesired consequences. Batteries frequently prove to be inadequate, undesirable, or even forbidden in specific measurement environments

The real-time availability of measuring data (e.g. for process control purposes) usually is another important aspect of the application. The use of wired sensors is particularly costly in environments with moving measurement objects and devices (translatory or rotatory motion; e.g. assembly lines, centrifuges, shafts, bearings, etc.). Not only are wired sensors difficult and costly to install in such environments (trailing cables, slip rings, etc.), they inflict further disadvantages when in operation (susceptibility to interference, high maintenance costs, etc.).

An "ideal" temperature measurement system should include the following features:

- wireless (without cable supply)
- battery-free (no need for integrated energy / power supply)

TEMPRIS (Temperature Remote Interrogation System) by iQ-mobil solutions GmbH is such a system. TEMPRIS works wirelessly and without batteries.

2.2 TEMPRIS Operational Principle

The TEMPRIS system is used for wireless temperature measurement and monitoring of up to 16 sensors without batteries. Radio wave transmission is used to supply the sensors with power and to query the sensor measurement data.

The TEMPRIS temperature sensors work on the principle of temperature-regulated resonators, i.e. small electrical circuits with special quartz crystals which are oscillated by an external electromagnetic field (carrier frequency 2.4 GHz, modulation frequencies approx. 10 MHz).

A temperature sensor query cycle starts with a receiving channel detection phase, followed by an excitation with a modulated signal. The excitation signal is demodulated by the receiving sensor, and the energy from this signal is preserved as oscillation energy by the sensor. The preserved sensor oscillation energy is then used to modulate the carrier frequency sent by the interrogation unit and to transmit the modulated signal back through the sensor antenna. The TEMPRIS interrogation unit receives this "backscatter" signal, converts it into digital data and calculates the temperature value contained in this data. The calculated temperature is transmitted via LAN connection to the TEMPRIS DataServer software on the connected PC where the temperature data is logged and visualized.

The TEMPRIS system is available in different configurations. Aside from a set of up to 16 wireless temperature sensors, each TEMPRIS system comes with an interrogation unit with either a single antenna for simultaneous transmit and receive operation or a multiplexer switch for operating up to 6 antennas simultaneously.

2.3 TEMPRIS Applications

TEMPRIS is especially suitable where the following requirements have to be met:

- wireless data transmission (measurement object in translatory or rotatory motion)
- battery-free data transmission (energy-saving, environment-friendly, low heat capacity)
- reproducible high precision of data measurement
- "real-time" data availability

TEMPRIS is available for a range of applications:

- Chemistry, Pharmacology, Medicine:
 - Reactors
 - Rotary mixers
 - Freeze dryers
 - Sterilizers
 - Medical monitoring
 - Handling of toxically / radioactive substances
- Industrial Plants:
 - Paper mills (calenders, etc.)
 - Transmissions
 - Anti-friction bearings
 - Flow furnaces
 - Engine development
 - Measurement of temperature distributions and gradients
 - High voltage overhead lines, transformer stations

3 TEMPRIS System Setup

3.1 TEMPRIS System Components

A typical TEMPRIS measurement system consists (at least) of the following system components:

- Interrogation Unit IRU-2 (PRO or LAB)
- External power supply
- HF Antenna(s)
- HF Antenna Cable
- up to 16 Sensors
- TEMPRIS DataServer software (recommended, but not required in case of direct control of the plant through PLC)

The following block diagram shows the TEMPRIS configuration with a single antenna.

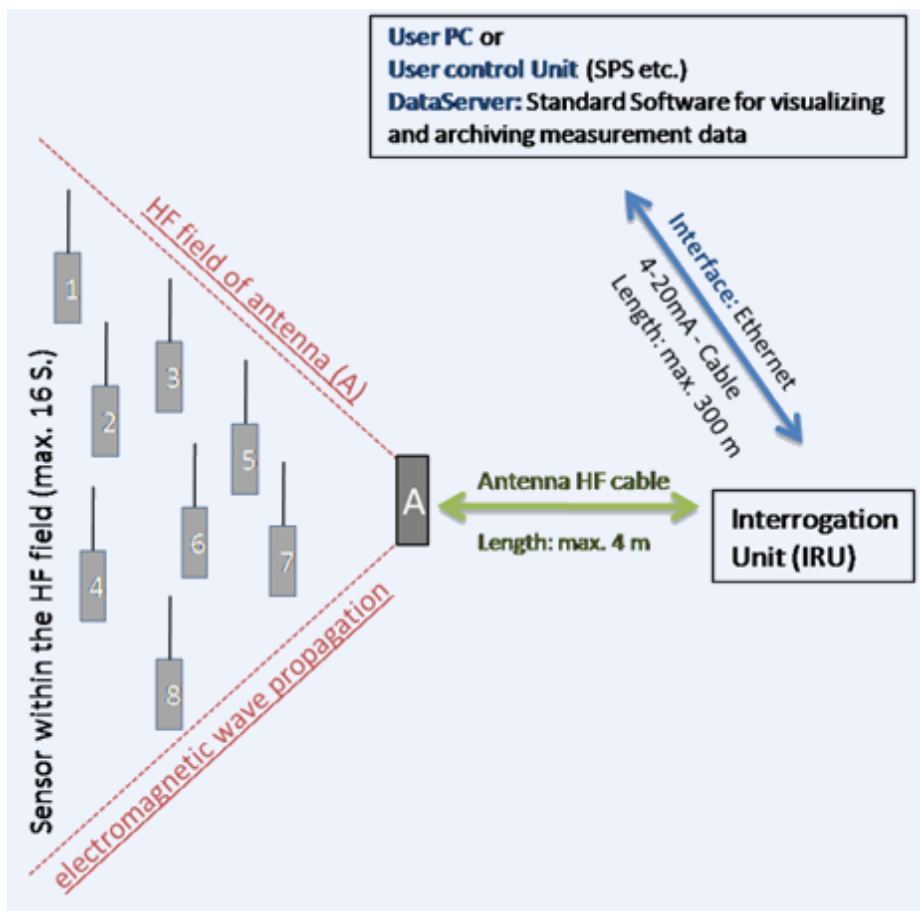

Figure 3-1: TEMPRIS Configuration with Single Antenna

The following block diagram shows the TEMPRIS configuration with multiple antennas.

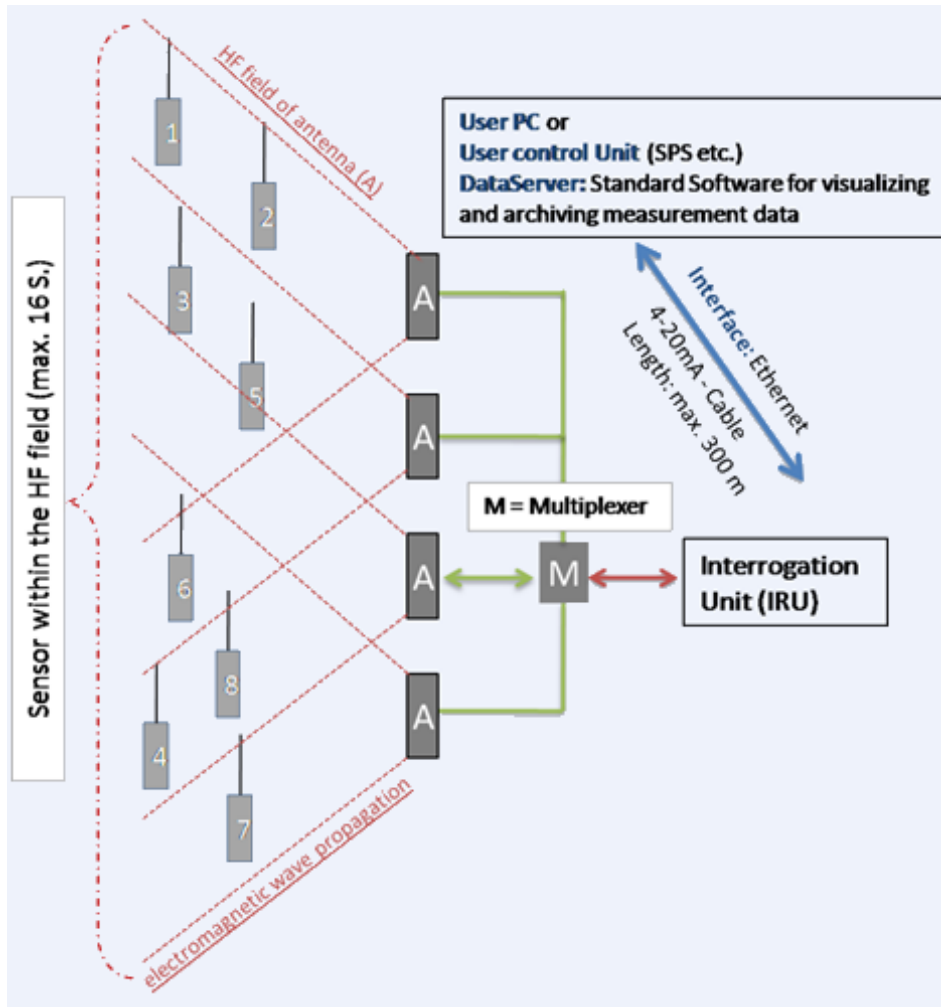

Figure 3-2: TEMPRIS Configuration with Multiple Antennas

3.2 Required Cable Connections

3.2.1 TEMPRIS PRO Connections and Interfaces

The sockets of the TEMPRIS PRO interrogation unit are labelled to limit the risk of incorrectly connecting the TEMPRIS device. The following image shows the power supply (label "P") and Ethernet (label "E") connections of the TEMPRIS PRO interrogation unit. The "C", "S" and "IO" connections are unused or for service purposes only.



Figure 3-3: TEMPRIS PRO Connections with Labels

The following image shows the TEMPRIS PRO antenna connection (label "A1").

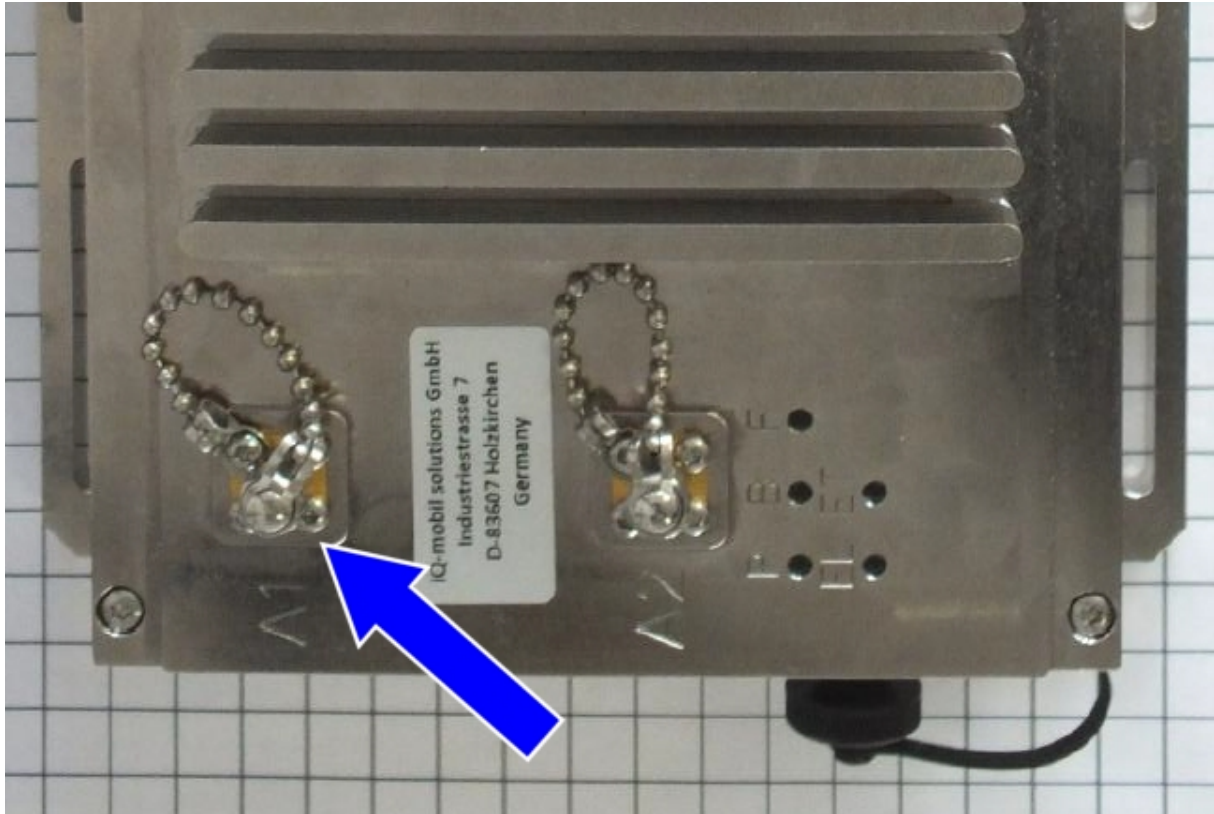

Figure 3-4: TEMPRIS PRO Antenna Connection A1

Note

You have to screw the antenna cable connection fully into the antenna socket A1 on the TEMPRIS interrogation unit. We recommend that you use a torque wrench to avoid any damage to the antenna cable.



Figure 3-5: Torque Wrench

The following image shows the (optional) TEMPRIS PRO antenna multiplexer connection (label "X").

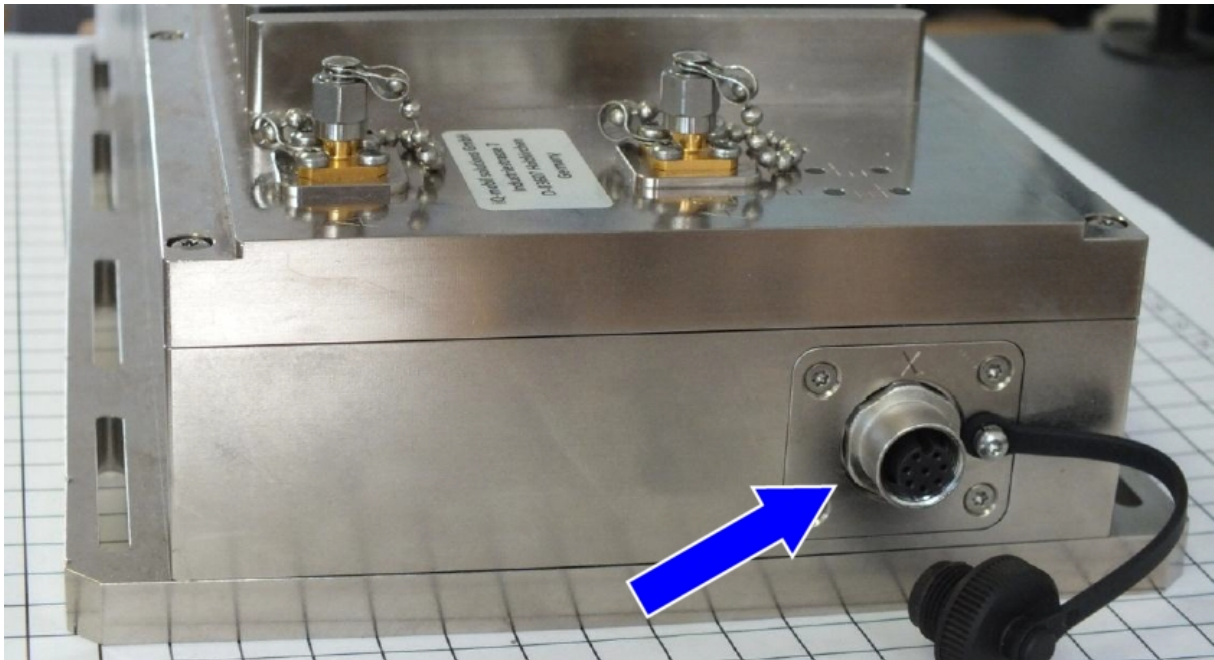
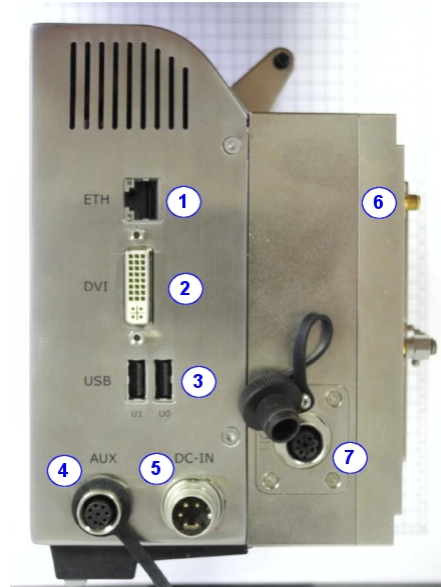

Figure 3-6: TEMPRIS PRO Antenna Multiplexer Connection X

3.2.2 TEMPRIS LAB Connections and Interfaces

The following image shows the TEMPRIS LAB connections and interfaces. TEMPRIS LAB provides two USB interfaces which can be used to connect peripheral USB devices such as keyboard, mouse, USB memory drive, external hard drive, etc.

- 1 External Ethernet connection
- 2 VGA Interface
- 3 USB-connections
- 4 AUX connection (optional)
- 5 Power Supply
- 6 SMA Antenna connection
- 7 Antenna Multiplexer connection (optional)



- 8 Data Storage
(only for service purposes)

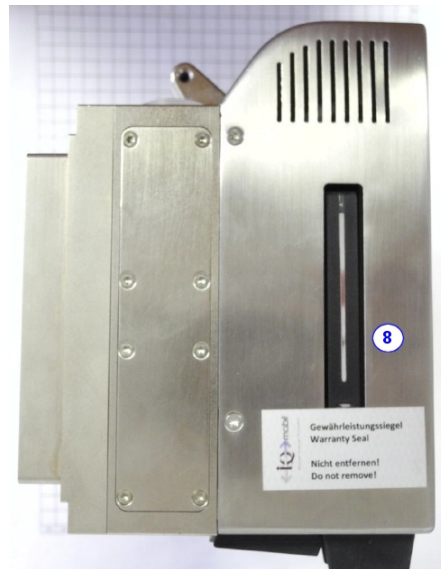

Figure 3-7: TEMPRIS LAB Connections and Interfaces

The following image shows the TEMPRIS LAB antenna connection (label "A1"). You have to screw the antenna cable connection fully into the antenna socket A1 on the TEMPRIS LAB interrogation unit. Take care not to damage the antenna cable in the process. We recommend that you use a torque wrench (see Figure 6-5).

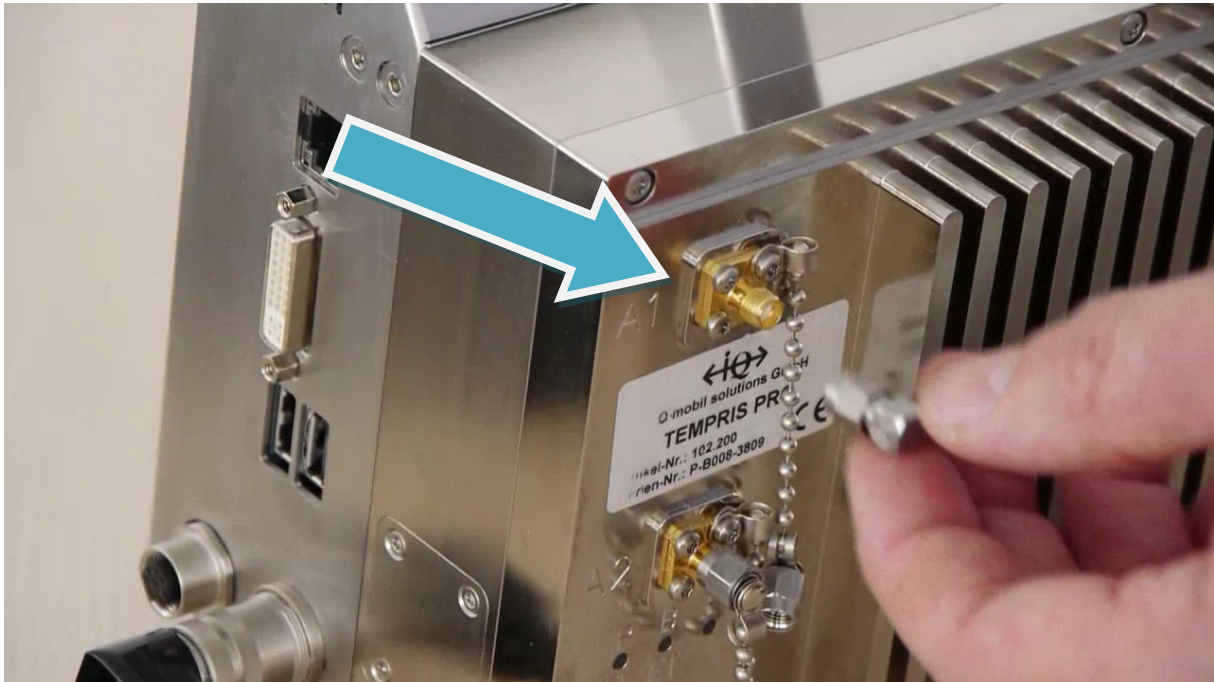

Figure 3-8: TEMPRIS LAB Antenna Connection A1

The TEMPRIS LAB system is equipped with touch screen functionality and a virtual keyboard option.

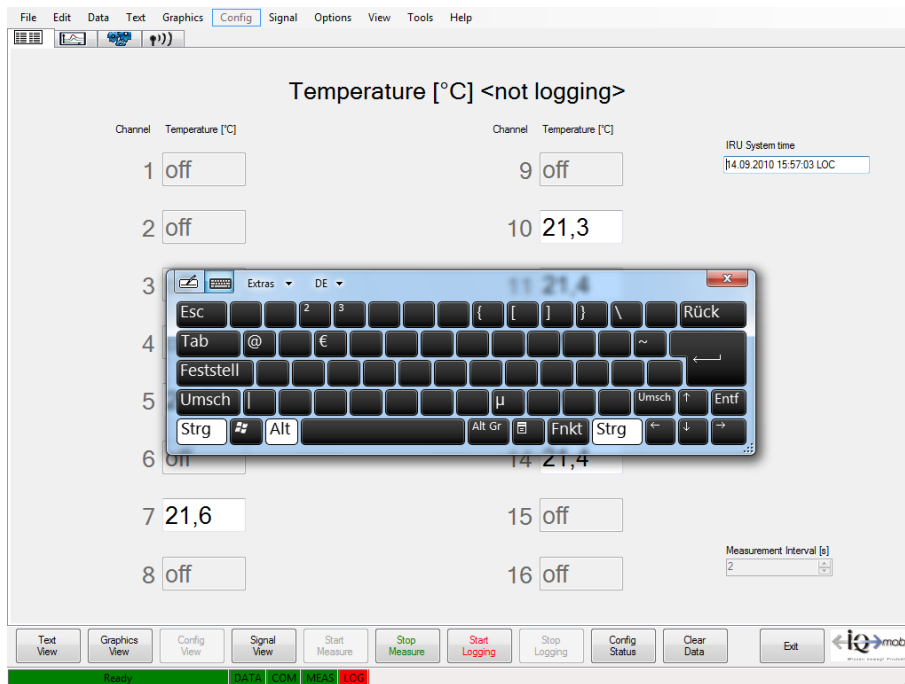

Figure 3-9: TEMPRIS LAB Virtual Keyboard

3.3 TEMPRIS DataServer Installation

TEMPRIS LAB systems are delivered with a valid TEMPRIS DataServer software installation. I.e., a TEMPRIS DataServer installation is usually only necessary for software updates and/or on computers for TEMPRIS PRO systems.

3.3.1 TEMPRIS DataServer System Requirements

The TEMPRIS DataServer software runs on different hardware platforms.

TEMPRIS LAB (laboratory system) comes with an integrated Windows 7 PC, which meets the system requirements listed in table 3-1. Please see [chapter 3.2.2](#) for external TEMPRIS LAB connections.

TEMPRIS PRO (production system) can be operated with a PC/laptop provided by iQ-mobil (recommended) or with your own PC/laptop with the system requirements listed in the table below. Please see [chapter 3.2.1](#) for the required cable connections.

Table 3-1: TEMPRIS DataServer System Requirements

Operating system	Microsoft Windows 7 / Vista / XP
Processor	>= 1 GHz
Main Memory (RAM)	>= 1 Gigabyte
Hard disk space	>= 10 Gigabytes
Screen / graphic resolution	Colour screen Resolution: 1280x1024 or higher Graphic enhancement recommended
Adobe Reader	for accessing/reading the supplied TEMPRIS DataServer User Manuals which are available in PDF format through Help - Manual
Web Browser (e.g. Internet Explorer)	For accessing/reading the supplied supplementary documentation which is available in HTML format through Help - Tutorial

3.3.2 New Installation

The TEMPRIS DataServer software is delivered with a memory-stick. Please navigate to the following directory on the memory stick:

`\DataServer`

Start the TEMPRIS DataServer setup program from the above directory:

`setup.exe`

Follow the instructions of the TEMPRIS DataServer setup program to complete the software installation.

Unless otherwise specified during setup, the TEMPRIS DataServer software is installed in the "Program Files" directory on drive C. The TEMPRIS DataServer setup program creates a TEMPRIS DataServer program icon on your desktop and in the Windows Start menu through All Programs - iQ-mobil - TEMPRIS DataServer.

3.3.3 Update Installation

If an old version of the TEMPRIS DataServer is already installed on your system, then you must remove the old version before installing the new version.

Once the old TEMPRIS DataServer is removed, you can proceed with the installation of the new version as described in [chapter 5.1](#).

4 TEMPRIS DataServer User Interface and Function Reference

This section describes the TEMPRIS DataServer software. I.e., the information in this section refers to PC-based TEMPRIS systems, and does not necessarily apply to PLC-based TEMPRIS systems. In case of PLC-based systems, it is, however, possible to operate the TEMPRIS DataServer software without any restrictions simultaneously with the TEMPRIS interrogation unit as data logger and/or visualization tool through a PC, laptop or Ethernet interface.

Please consider the following advice before starting TEMPRIS DataServer:

- Please deactivate any features, which could trigger automated Windows restarts (such as, e.g., "Restart after automatic updates"), as this will interrupt any active data logging and might result in the loss of valuable measuring data.
- In principle, there are no lock-ups of access to the TEMPRIS DataServer operation. Access is, however, logged in a special activity log, so that the use of the TEMPRIS DataServer is traceable. In case of sensitive data situations, it is, therefore, recommended to set up different access accounts (with PASSWORD) under Windows. These will then be logged, and will make the respective user recognizable in chronological order.

In a TEMPRIS system, the following important definition is valid:

The term "channel" indicates the assignment ("mapping") of a TEMPRIS sensor to a TEMPRIS data stream (data record). Sensor to channel assignments allow for measurement data from different sensors to be distinguished. TEMPRIS supports up to 16 sensor assignments, thus supporting simultaneous monitoring of up to 16 temperature measurement data channels. Sensors with different frequencies are assigned to different channels unless a special setup (e.g., with antenna multiplexing) is being used. The sensor assignments are stored in TEMPRIS configuration files. The "**Config View**" (see chapter 6.5.) provides functions for saving and loading TEMPRIS configuration files for different sensor sets, antenna configurations, etc.

4.1 TEMPRIS DataServer Features

With TEMPRIS DataServer, you can

- configure your TEMPRIS system according to your requirements:
 - Select the number of active sensors (1 to 16) – Load/set sensor calibration coefficients (polynomial)
 - Select the desired interface(s)
 - Select the desired data rate
 - Select the sensor measurement range
 - Optionally assign sensors to different antennas (“multiplexing”)
- save TEMPRIS measuring data permanently (“logging”):
 - Select log directory and log file name
 - Activate and deactivate data logging
- visualize TEMPRIS measuring data online or offline:
 - Temperature sequences in graphic form (“Plots”)
 - Temperature representation in numeric form (“Listings”)
 - Representation of the measuring data quality (S/N, signal to noise-ratio)
 - Selection and windowing of measuring data (zoom functions)
 - Representation of temperature distributions (3D)
- distribute and retrieve TEMPRIS measuring data over a network via:
 - Ethernet
 - Modbus 4 to 20 mA Current Loop interface
- print TEMPRIS measuring data (“hardcopy” function)
- organize data access and system configurations:
 - Password protection, “traceability”
 - Protection of log files against manipulation (“21 CFR Part 11”)

4.2 Program Start

The TEMPRIS DataServer can be started by double-clicking the TEMPRIS DataServer program icon on the desktop or in the Windows **Start** menu.

Please note that the TEMPRIS DataServer start-up procedure can last up to some 20 seconds.

4.1.1 TEMPRIS LAB Start-up Screen

TEMPRIS LAB automatically runs the **Connect** command (see [chapter 7.4](#)) upon start-up, thus triggering the display of the "Current Configurations Setup" dialog as shown in the following screenshot.

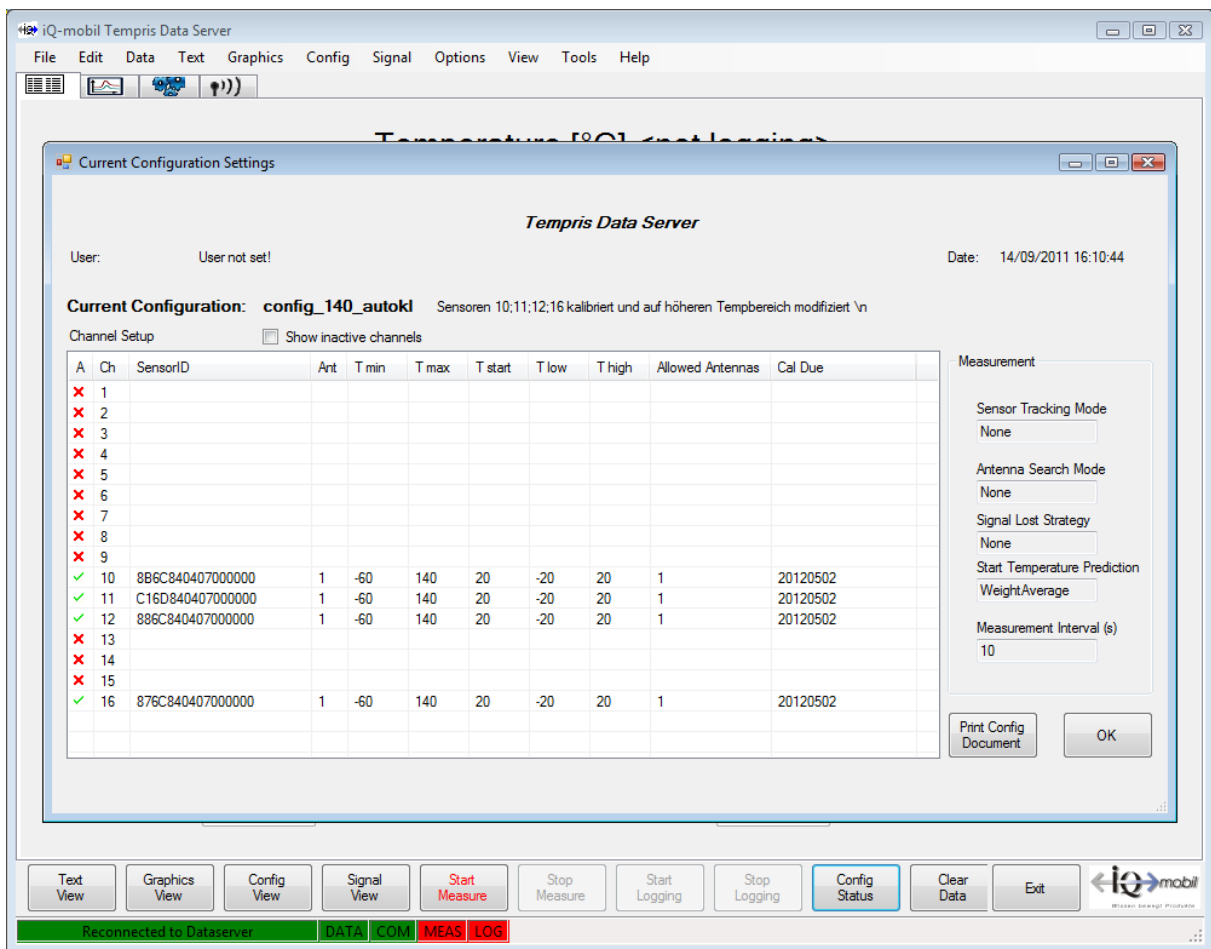

Figure 4-1: TEMPRIS LAB Start-up Screen

4.1.2 TEMPRIS PRO Start-up Screen

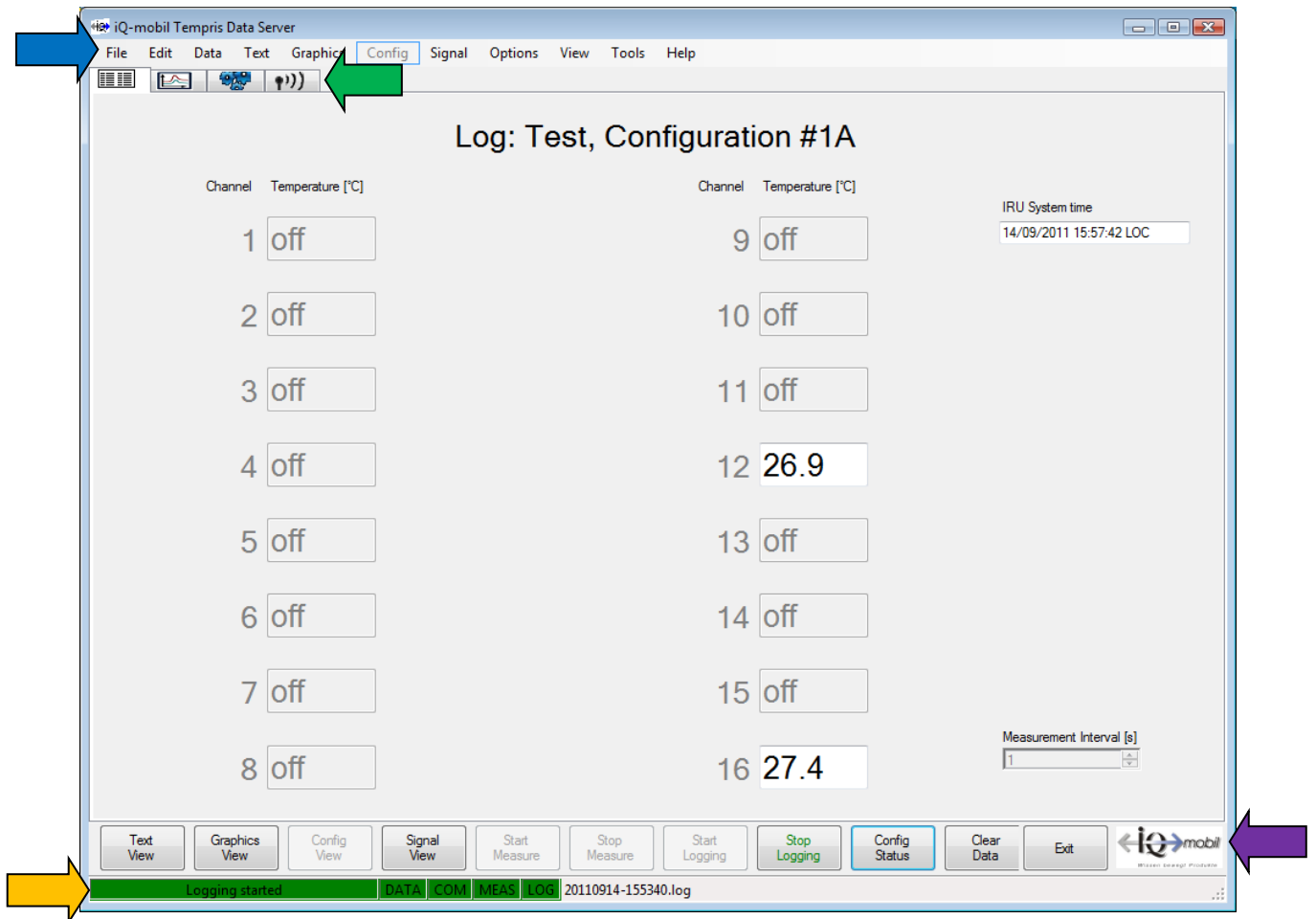





Figure 4-2: TEMPRIS PRO Start-up Screen

The TEMPRIS DataServer user interface includes of the following special areas:

-  Menu Bar
-  Function Tab
-  Toolbar with Command Buttons
-  Status Bar

The respective menu items and command buttons are described in the following chapters.

The function tab contains **View** commands for selecting different views. For easier touchscreen operation, these commands are also provides through large command buttons in the toolbar at the bottom.

4.3 Status Bar

The following figure shows the TEMPRIS DataServer status bar elements.

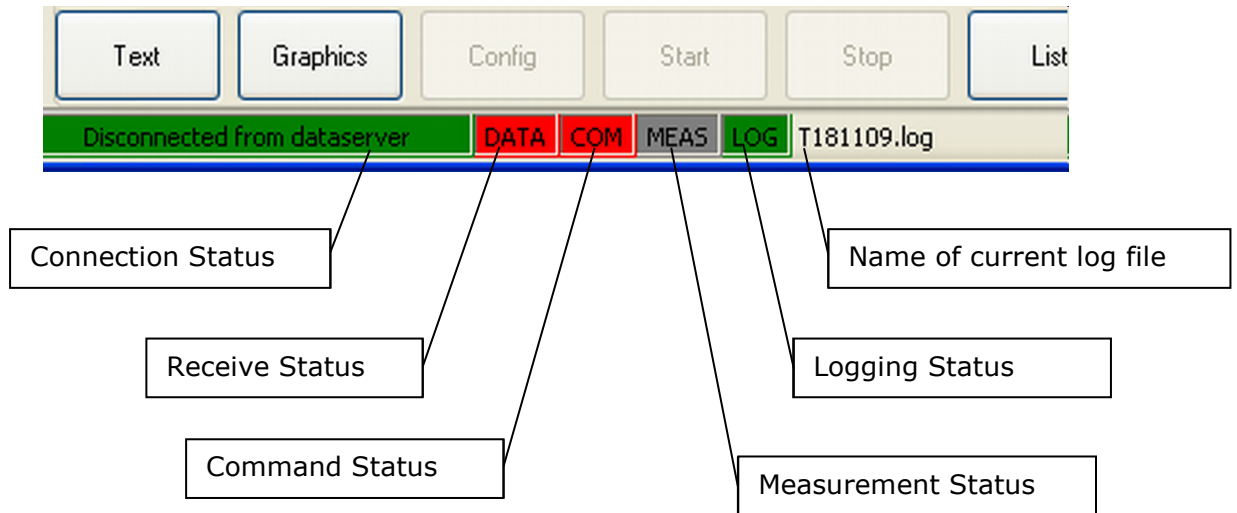

Figure 4-3: TDS Status Bar Elements

Table 4-1 provides an overview of TEMPRIS DataServer status bar elements and messages.

Table 4-1: TEMPRIS DataServer Status Bar Elements

Status Bar Element	Display
Connection Status	Ready Connected Disconnected from DataServer Error message
Receive Status	DATA = data link connected DATA = data link disconnected
Command Status	COM = command link connected COM = command link disconnected
Measurement Status	MEAS = measuring started MEAS = measuring stopped MEAS = measuring status undefined
Logging Status	LOG = logging on log file switched on LOG = logging on log file switched off

4.4 Interface Configuration

The TEMPRIS DataServer communicates with the TEMPRIS interrogation unit through an Ethernet connection. The **Options** - **Connection** function activates a dialog for configuring the Ethernet connection.

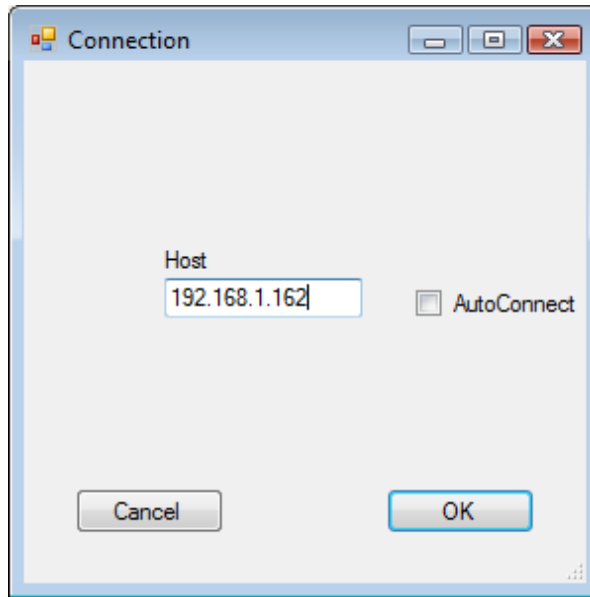

Figure 4-4: TDS Options - Connection

The “Host” field in the **Connection** dialog displays the IP address of your TEMPRIS interrogation unit. In most cases the factory setting for the IP address should work. However, the IP address can be changed should this be necessary to resolve an address conflict with another device on your network.

The **AutoConnect** option causes the TEMPRIS DataServer software to connect automatically to the specified IP address upon program start-up. We recommend to activate the **AutoConnect** option on TEMPRIS LAB systems.

Clicking the **OK** button activates the current dialog settings and stores them permanently on your computer.

Notes

- Make sure that the provided Ethernet cable is plugged in between the TEMPRIS interrogation unit and your computer or laptop.
- In accordance with your data, the IP address has been preset by factory in correspondence with the IP address of your computer / laptop. You can find the preset IP address on a label of the TEMPRIS controller casing. This IP address is temporary, the user has the possibility of changing this address later (see documentation IRU-2 maintenance), e.g. in case of computer replacement, etc. It is recommended to note the changed IP address and to change the label on the casing accordingly.
- Your interface selection and configuration is stored on your computer and is automatically loaded when the TEMPRIS DataServer is started the next time.

4.5 Establishing the Data Connection between PC and TEMPRIS Interrogation Unit

Note

The TEMPRIS DataServer of the TEMPRIS LAB version automatically connects to the TEMPRIS interrogation unit upon start-up.

In case of current measurement / logging operation, you have to stop both logging with **Stop Logging** (see Figure 7-5) and the measurement with **Stop Measure** (see Figure 7-6).



Figure 4-5: TDS Toolbar - Stop Logging

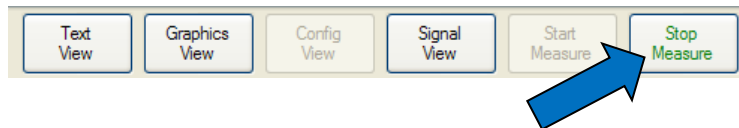

Figure 4-6: TDS Toolbar – Stop Measure

After configuring the Ethernet interface (see [chapter 4.4](#)), the PC or laptop can connect to the TEMPRIS interrogation unit with the **Connect** or the **Receive Data** function from the **File** – **Connect** submenu.

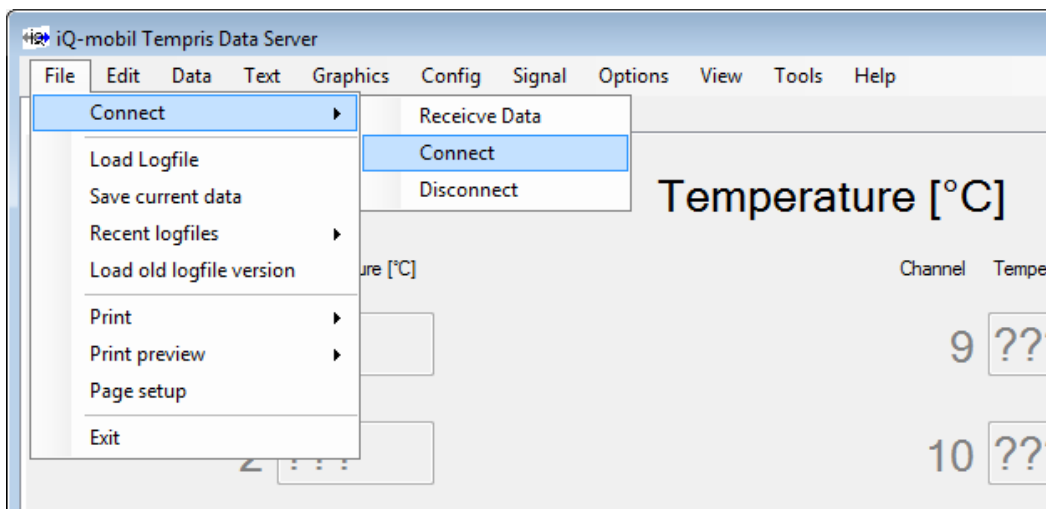

Figure 4-7: TDS File – Connect Submenu

Connect All enables both data and command communications (bi-directional). **Connect All** mode is indicated in the status bar as follows:

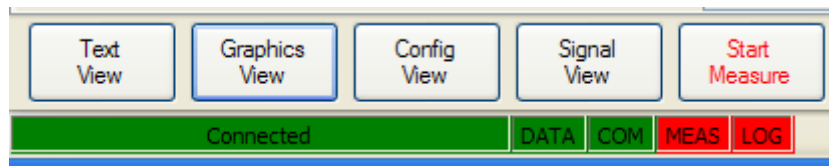

Figure 4-8: TDS Status Bar – Connect Indicators

Receive Data enables data communications only (only **DATA** receipt, no **COM**mands). **Receive Data** mode is indicated in the status bar as follows:

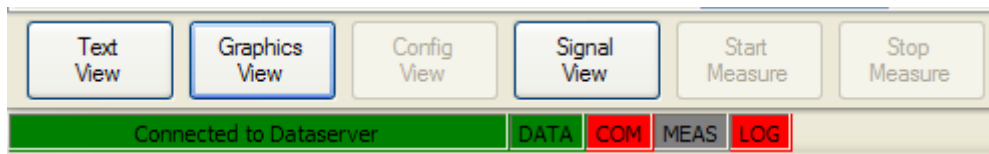

Figure 4-9: TDS Status Bar – Receive Data Indicators

The **Disconnect** function from the **File** – **Connect** submenu stops any active logging and measurement on the PC and closes the existing interrogation unit.

4.6 Config View

The „**Config View**“ for displaying and configuring the TEMPRIS system settings can be activated with the **Config View** function from the **View** menu or by clicking the corresponding function index tab. Please note that the **Config View** function is only available if a connection between the TDS software and the TEMPRIS interrogation unit is established (with the **Connect** function from the **File – Connect** menu and neither logging nor measuring is active).

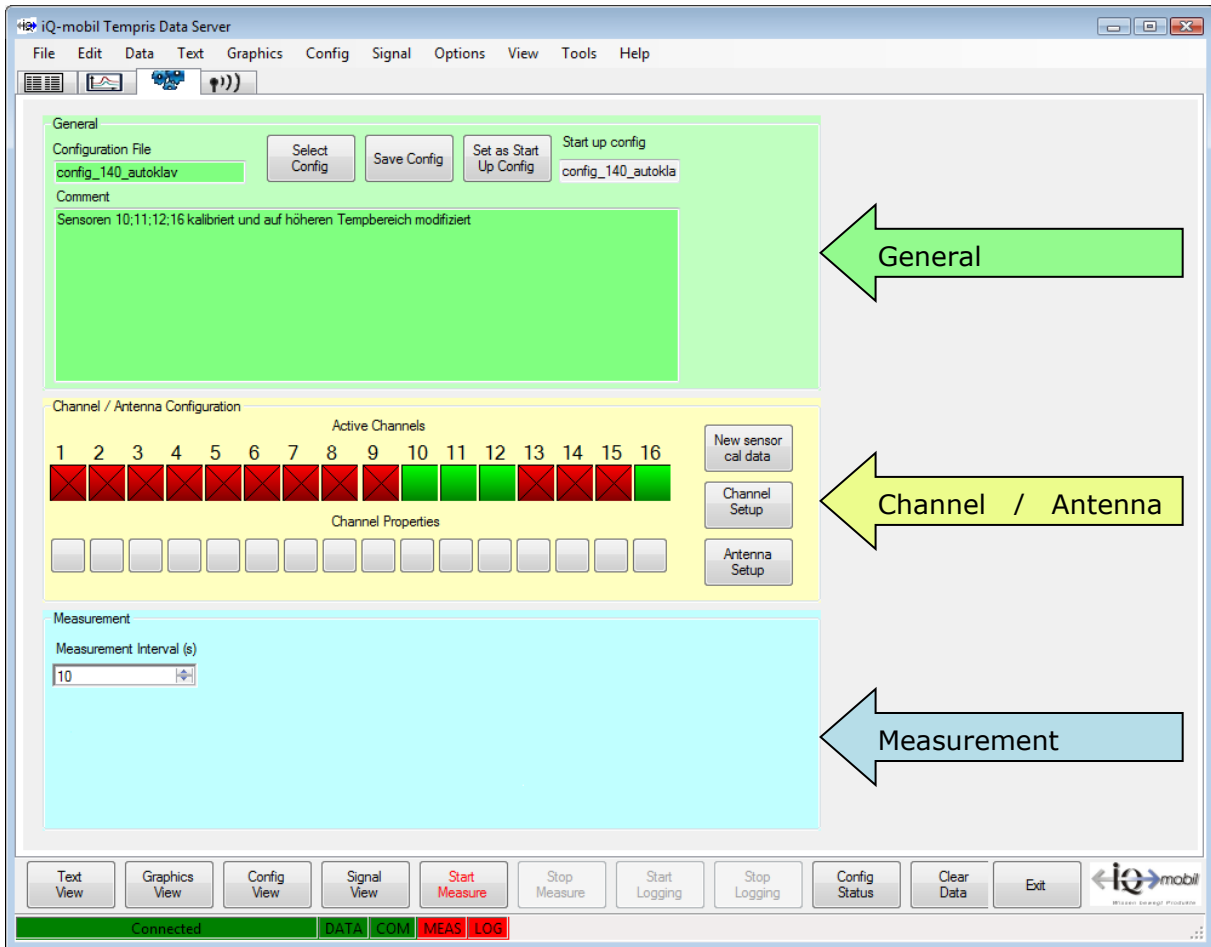

Figure 4-10: TDS Config View

The TDS “Config View” consists of several blocks which are described in the following sections.

4.6.1 Config View - General

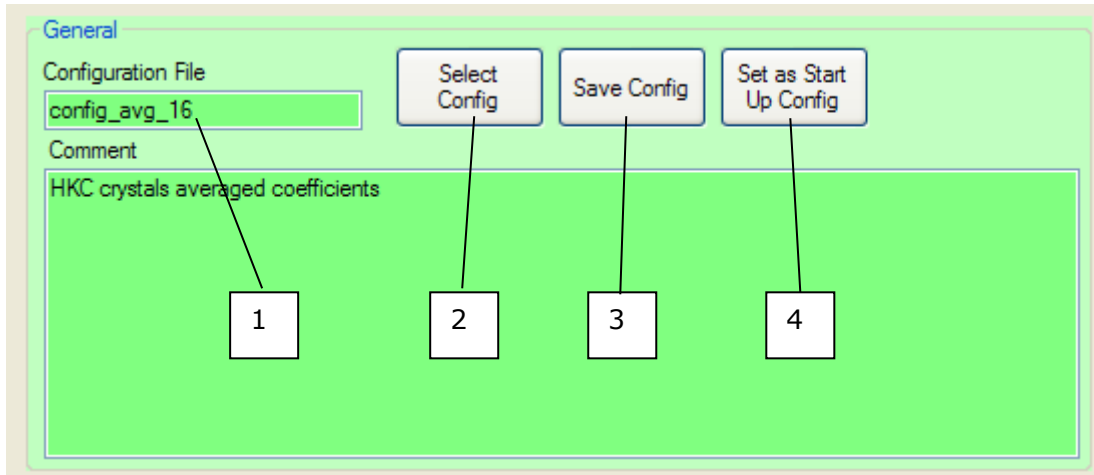

Figure 4-11: TDS Config View - General

The "General" block of the "Config View" provides the following controls and functions:

- The currently loaded configuration file **(1)**
- Button Select Config for selecting/loading a saved configuration **(2)**
- Button Save Config for saving the current configuration **(3)**
- Button Set as Start Up Config for selecting an existing configuration file as default configuration to be loaded upon start-up **(4)**

“Select Config” (2):

The **Select Config** function activates a dialog for selecting and loading an existing configuration file:

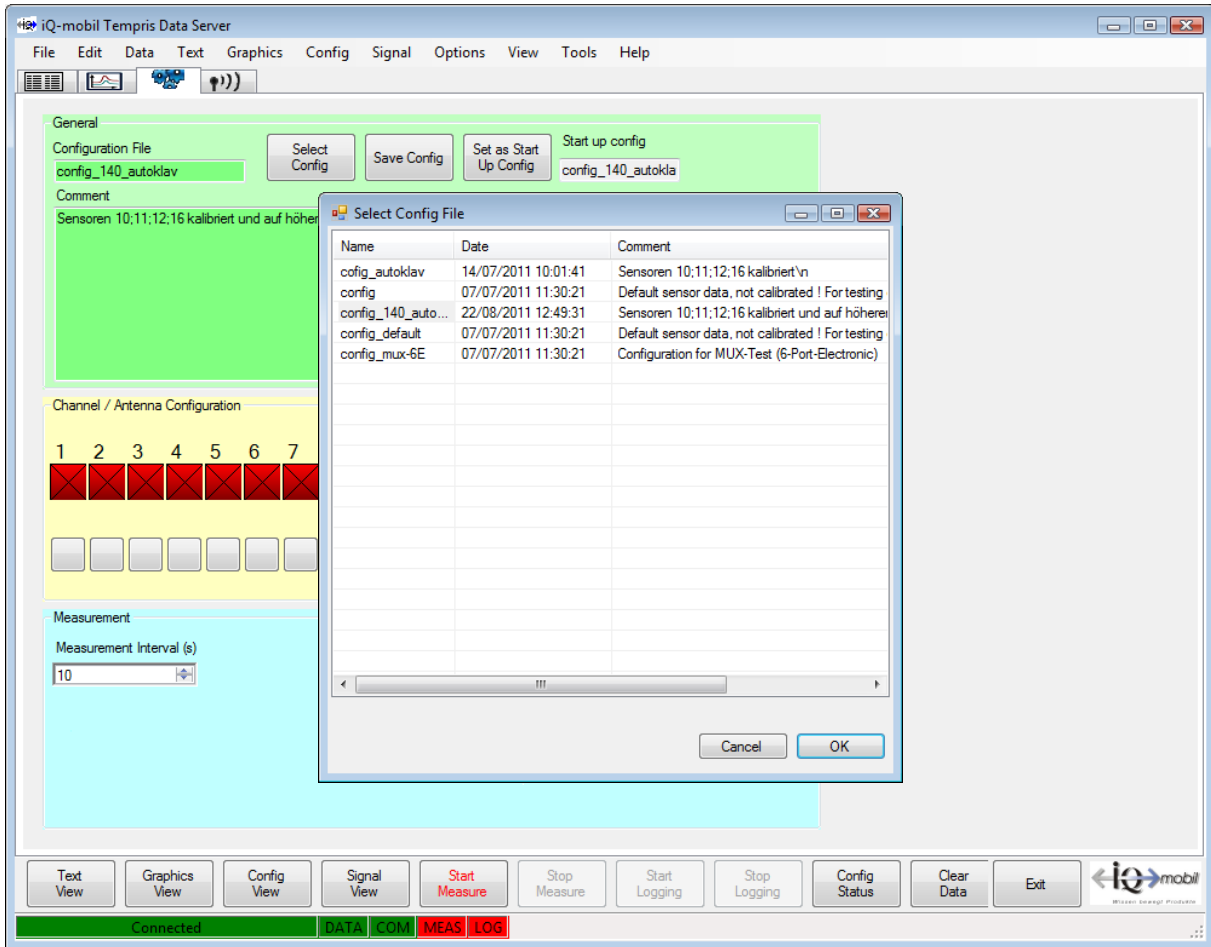

Figure 4-12: TDS Config View – General – Select Config

Save Config (3):

The **Save Config** function activates a dialog for saving the current configuration to a configuration file. Selecting an existing configuration file overwrites the configuration in that file. The **New** option allows for the creation of a new configuration file with user-defined name and optional comments.

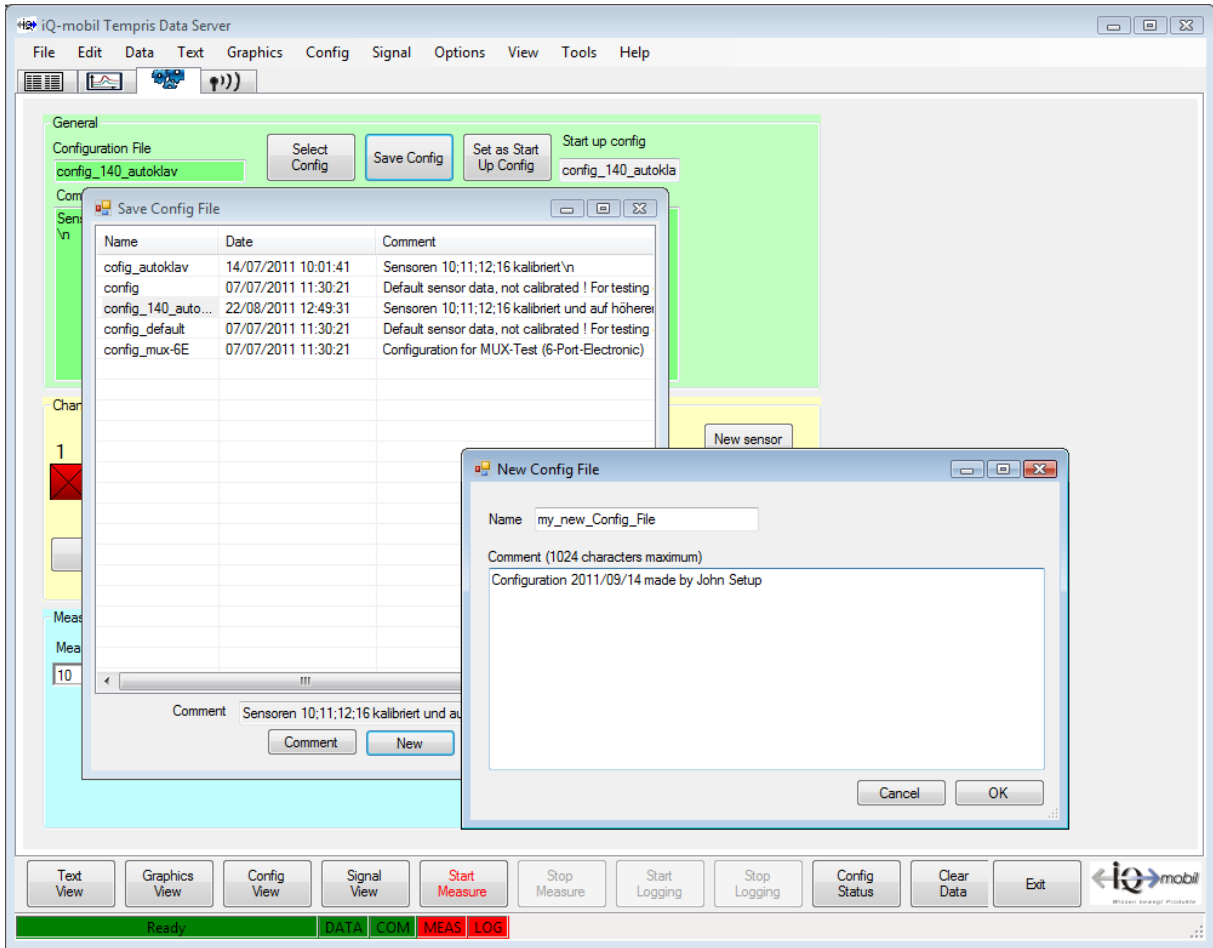

Figure 4-13: TDS Config View – General – Save Config

4.6.2 Config View - Channel / Antenna Configuration

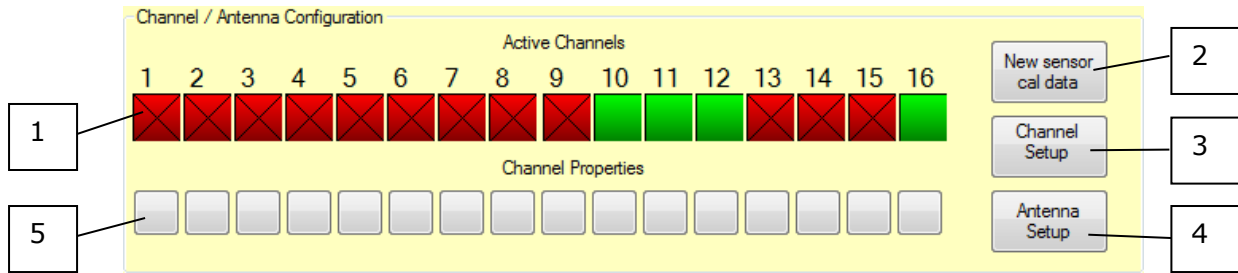

Figure 4-14: TDS Config View – Channel / Antenna Configuration

The “Channel / Antenna Configuration” block of the “Config View” provides the following controls and functions:

- Activation / Deactivation of measurement channels **(1)**
- **New sensor cal data** loads sensor calibration data **(2)**
- **Antenna Setup** assigns antennas to channels **(3)**
- **Channel Setup** displays the channel assignments **(4)**

(1) Active Channels

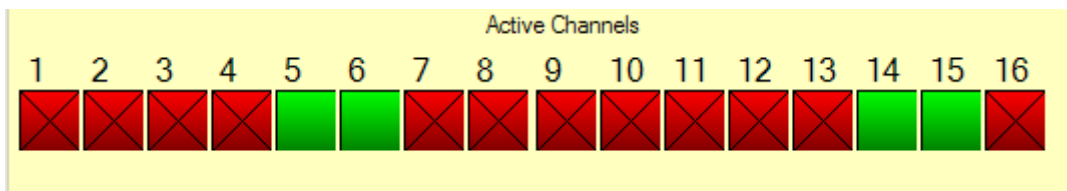

Figure 4-15: TDS Config View – Channel / Antenna Configuration – Active Channels

Green channel buttons are used to indicate activated channels. I.e., only the green marked channels, respectively the sensors assigned to these channels, are activated for measurement. Clicking a channel button toggles between channel “activated” (green) and channel “deactivated” (red) mode. In the example above, the channels 5, 6, 14 and 15 are selected for measurement.

(2) New sensor cal data

The **New Sensor cal data** function allows (after recalibration or the use of new / additional sensors) the loading of the corresponding calibration data from the PC / laptop on the interrogation unit and their storage.

(3) Antenna Setup

The **Antenna Setup** function allows the corresponding assignment in case of antenna multiplexing.

(4) Channel Setup

The **Channel Setup** function allows querying the current activation status of individual channels (sensors) and corresponding measuring ranges.

The following screenshot shows a channel setup query with channels 5, 6, 14 and 15 activated.

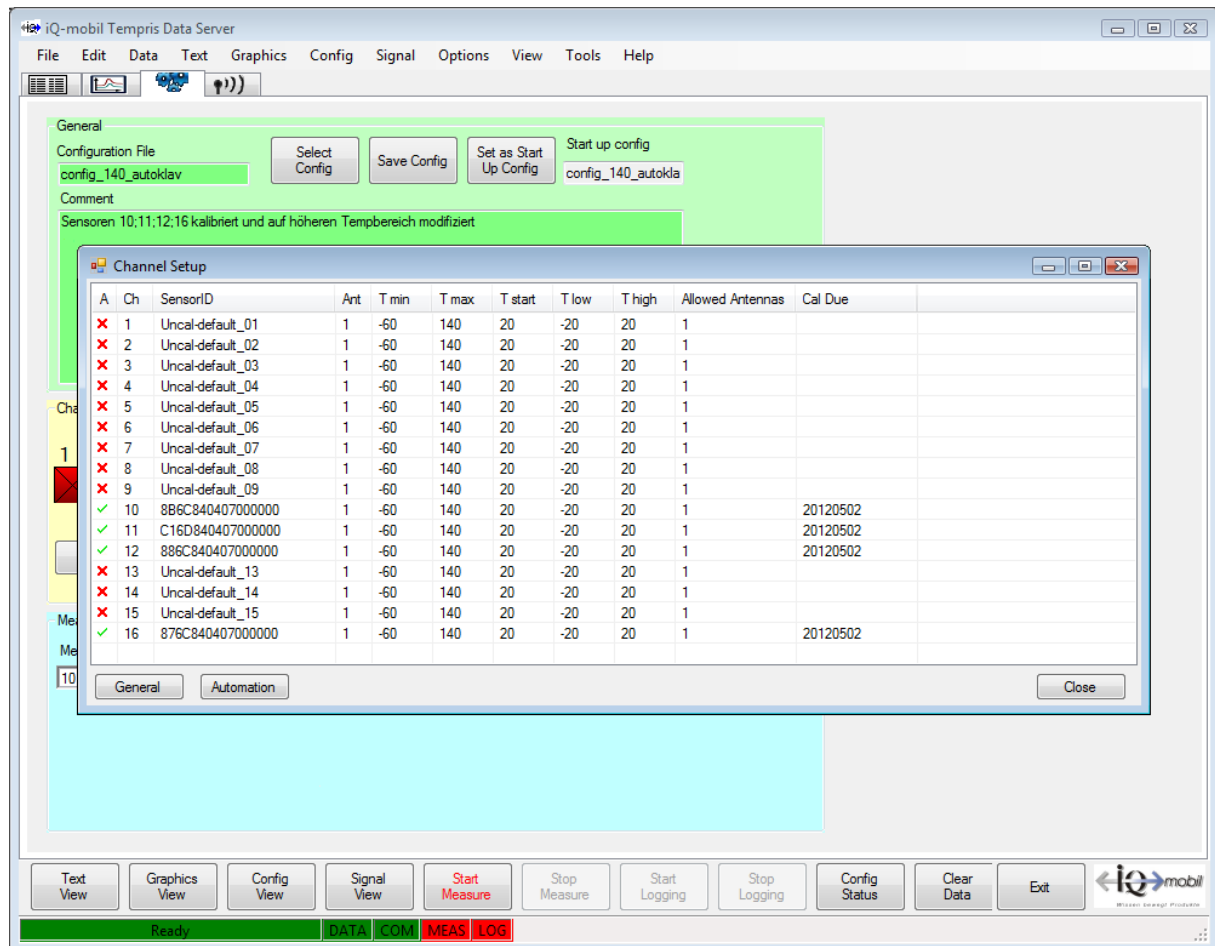

Figure 4-16: TDS Config View – Channel / Antenna Configuration – Channel Setup

The TEMPRIS data collection process supports different search strategies for finding the sensors in the antenna field of the TEMPRIS interrogation unit. The TEMPRIS sensor search procedure is similar to an automated channel scan on a car radio tuner. In order to search as efficiently as possible, a search area has to be selected (similar to the FM, VHF, etc. band selection on the car radio tuner).

The TEMPRIS search area is defined through the following temperature parameters:

- **Tmin** Temperature measuring range lower limit [°C]
- **Tmax** Temperature measuring range upper limit [°C]
- **Tstart** Temperature search start value [°C]
- **Tlow** Temperature search range lower limit [°C]
- **Thigh** Temperature search range upper limit [°C]

The assignment status of a channel is displayed in a tool tip when the mouse pointer is moved over the channel indicator as illustrated in the following screenshot.

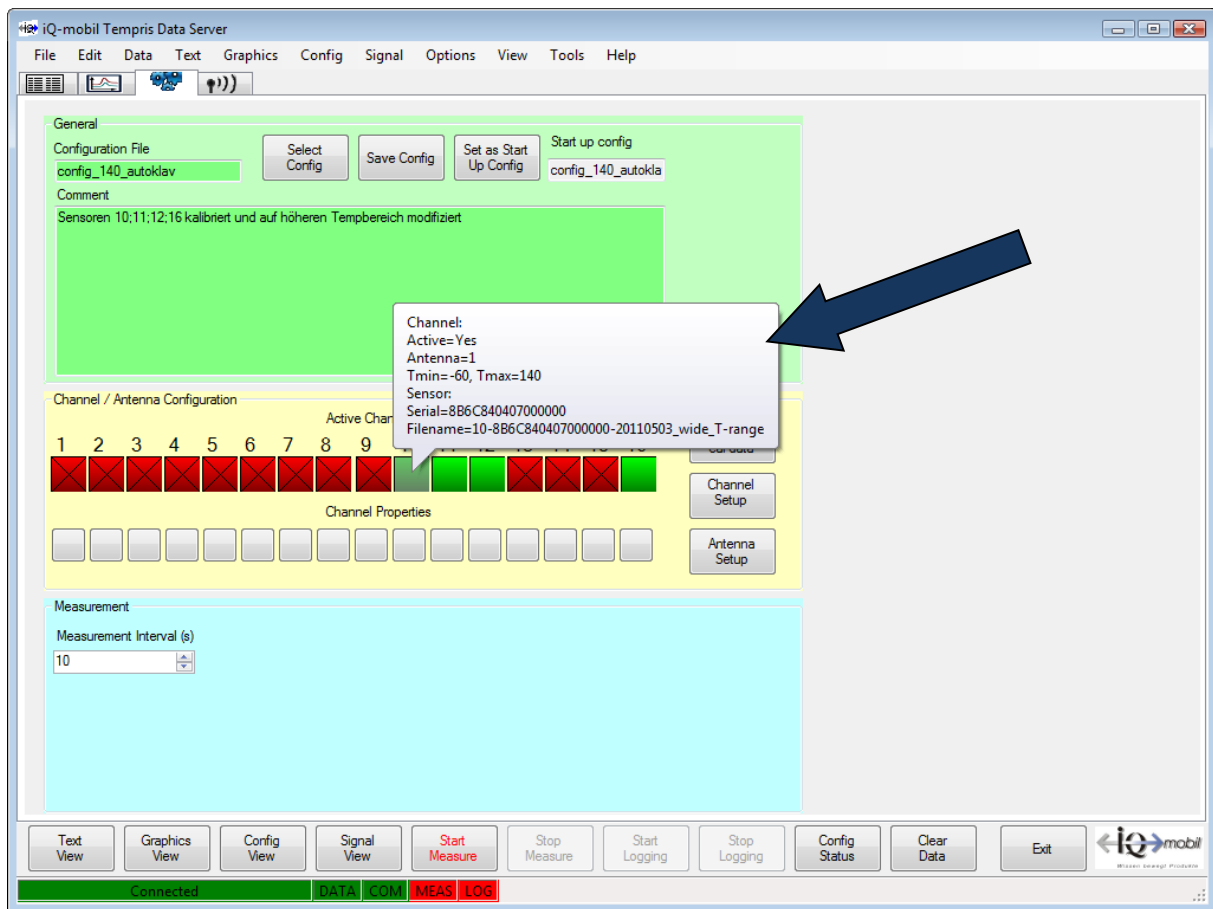

Figure 4-17: TDS Config View – Channel / Antenna Configuration – Channel Tooltips

The measuring range and search parameters can be adjusted for each channel by clicking the channel indicator with the right mouse button:

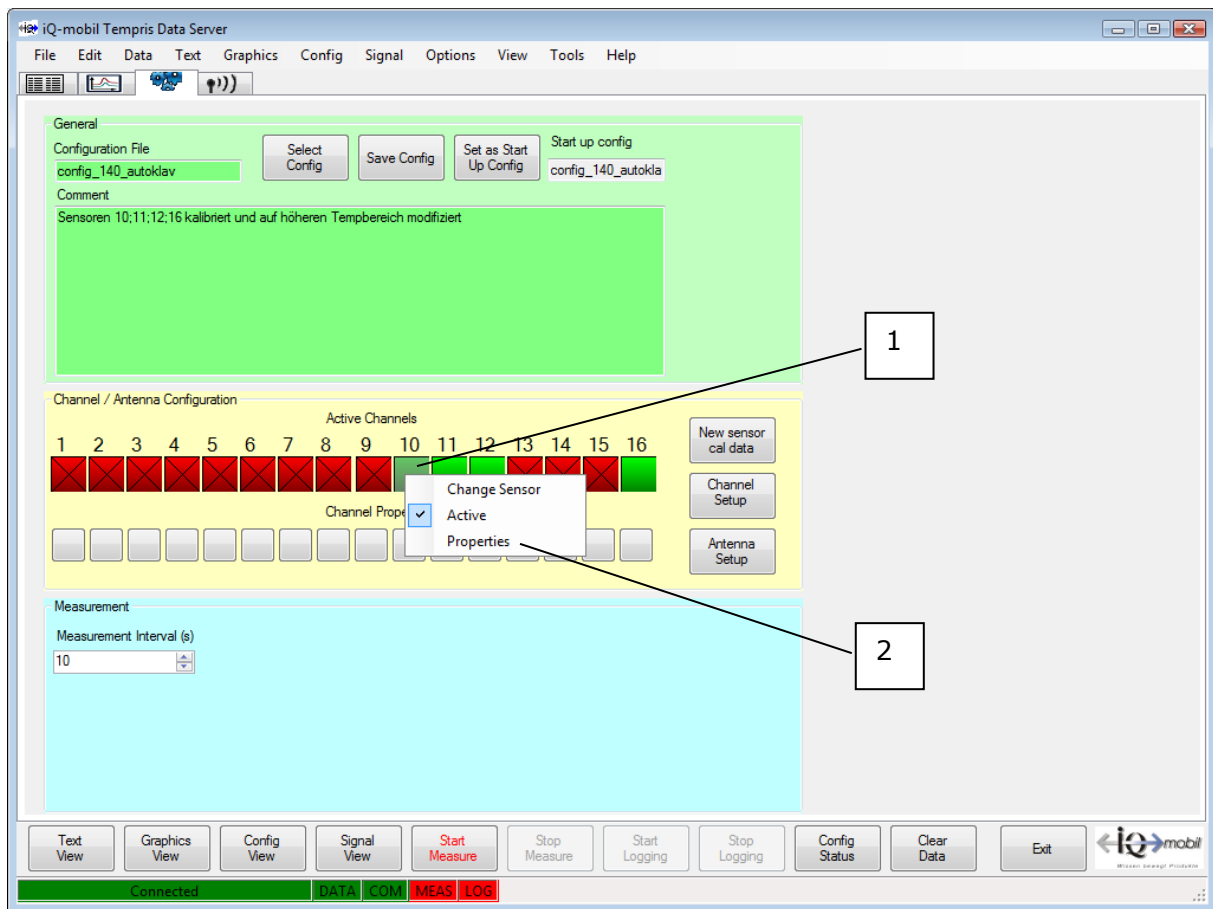

Figure 4-18: TDS Config View – Channel / Antenna Configuration – Channel Settings

(1) Active Channels - Change Sensor:

The **Change Sensor** button activates a dialog for loading a sensor calibration file for the selected channel/sensor.

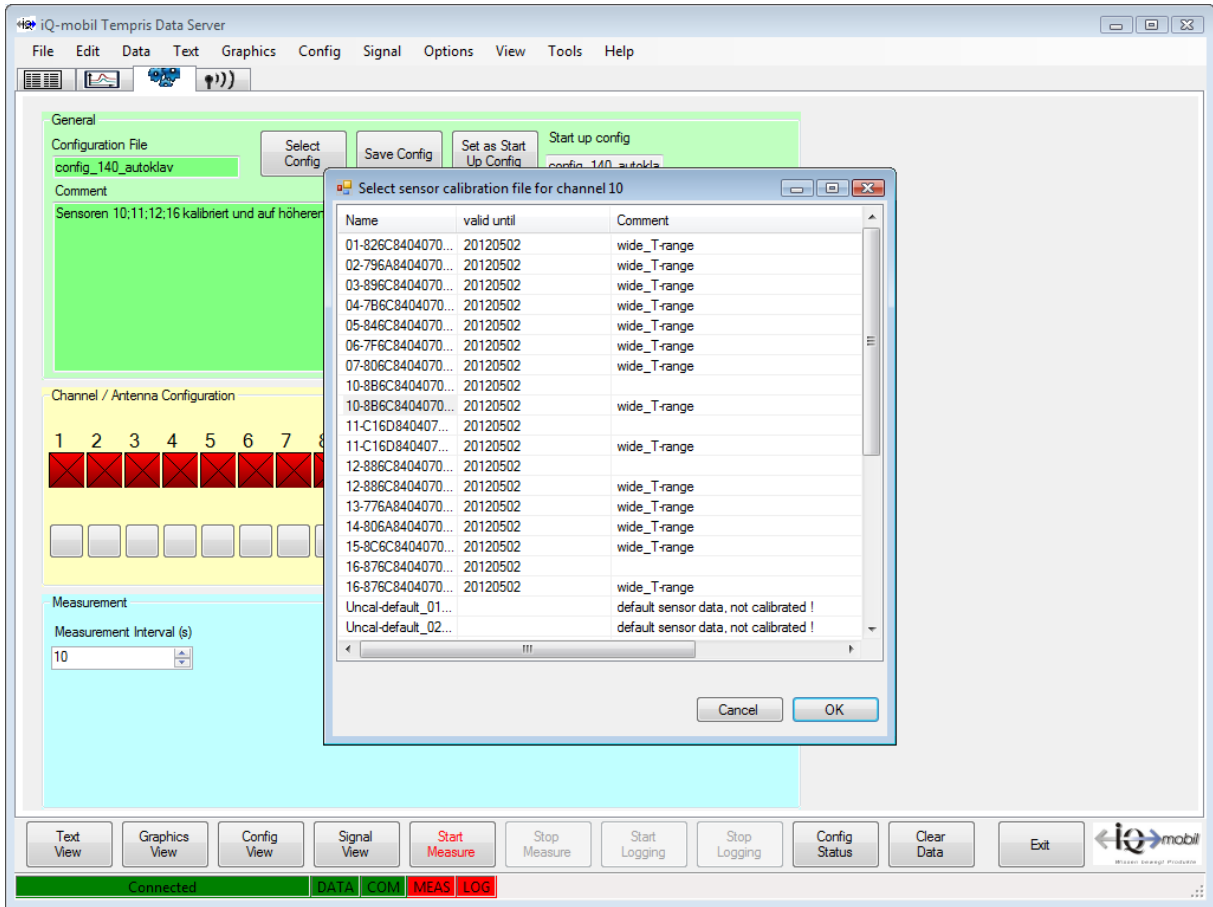

Figure 4-19: TDS Config View – Channel / Antenna Configuration – Change Sensor

(2) Active Channels – Channel Properties:

The **Properties** button activates a dialog for displaying and specifying the measuring range limits and search parameters for the selected channel/sensor. The **Apply all...** button assigns the currently entered parameters to all channels/sensors.

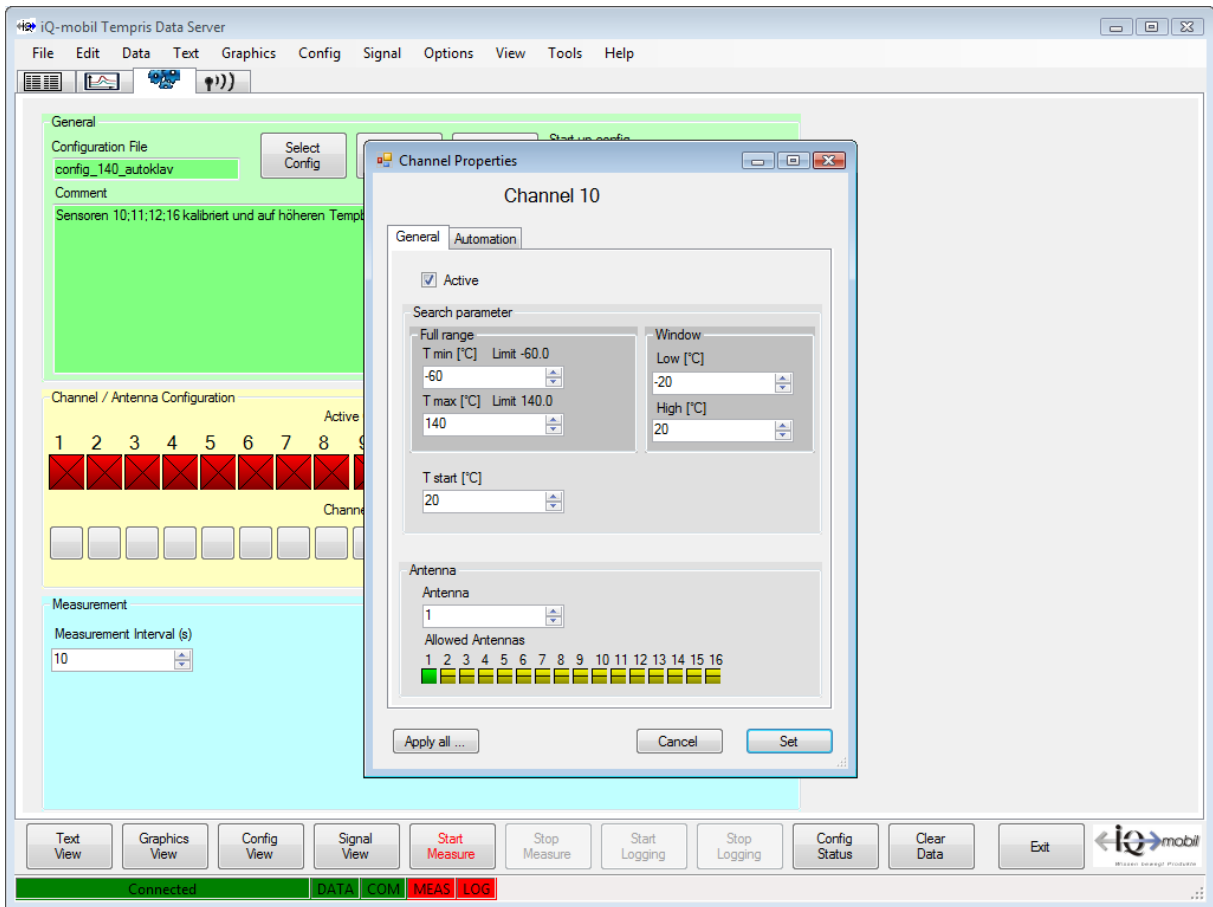

Figure 4-20: TDS Config View – Channel / Antenna Configuration – Channel Properties

4.6.3 Config View - Measurement



Figure 4-21: TDS Config View - Measurement

The "Measurement Interval(s)" control sets the time resolution (time interval of measurement points) for the active channels.

4.7 Text View

As soon as the controller is connected, data from the activated channels is delivered if these are in reachable distance in the antenna field of the controller. During active measurement, the TEMPRIS interrogation unit continuously carries out a so-called sensor search over the frequency ranges of the activated sensors. The duration of the search period depends on various parameters (number of activated sensors, size of the search window/range, signal quality, etc.).

You can switch between different views for displaying incoming data.

The „Text View“ for displaying the monitored temperature values can be activated with the **Text View** function from the **View** menu or by clicking the corresponding function index tab.

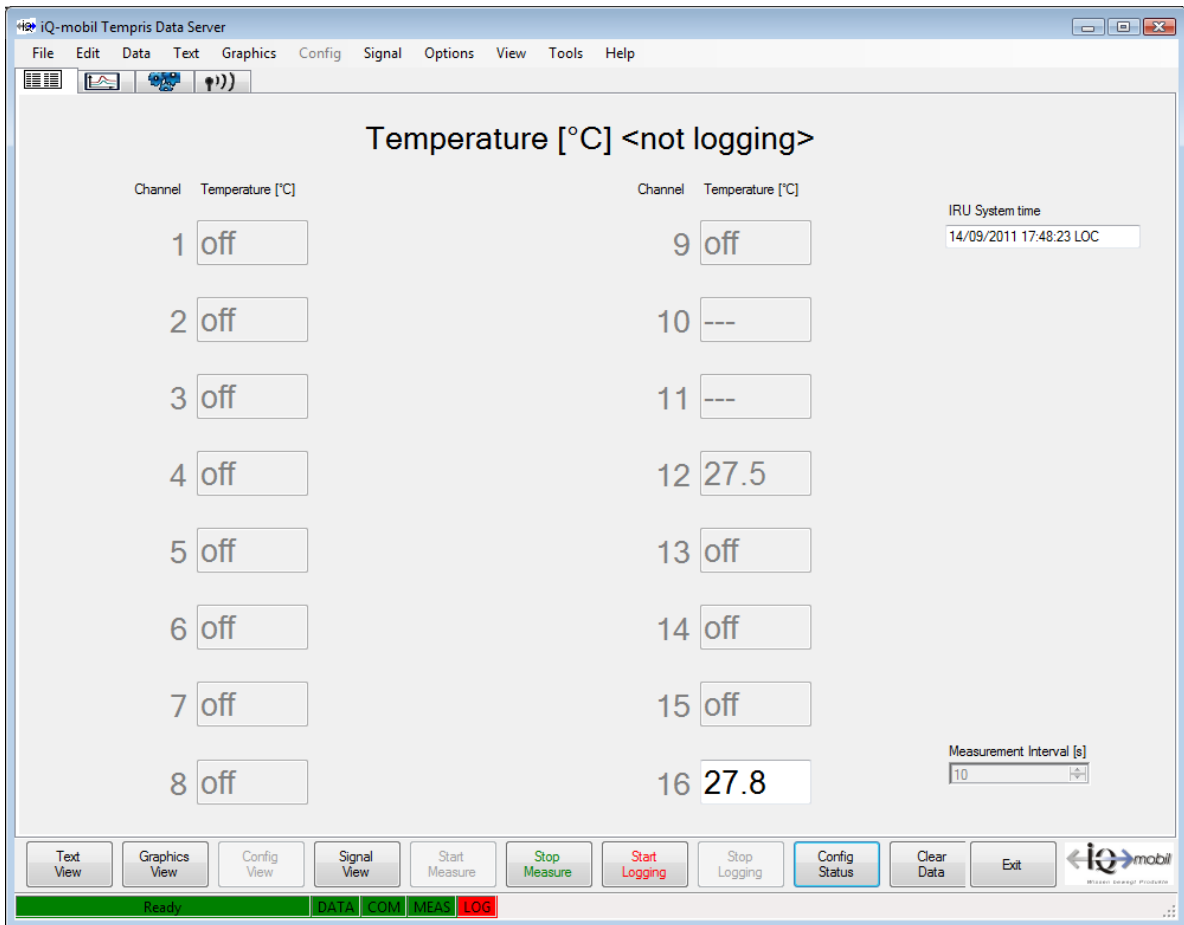

Figure 4-22: TDS Text View

“Text View” displays the incoming values of the active measuring channels in the selected temperature units (Celsius, Fahrenheit, Kelvin). Please note that the temperature values are displayed with one decimal digit, yet the internal precision for storing the temperature values in the TEMPRIS log files is much higher (<0.01° Kelvin).

The text view displays the temperature values in two columns. Channels 01 through 08 are displayed in the left column, and channels 09 through 16 are displayed in the right column.

Inactive channels are greyed and marked with **“off”**.

If a channel (sensor) temporarily disappears out of the antenna field (in the example above, the channel 14 has been briefly removed from the field), the last measured temperature value (in the example 22.6°C) is represented in grey writing. As soon as a “grey” channel (sensor) re-enters the antenna field, the currently measured temperature value reappears in normal (black) writing.

In the right upper field of the screen, the time of the last measurement is updated.

The following temperature display units can be selected thorough **Options** – **Preferences** (see below):

- **Celsius**
- **Fahrenheit**
- **Kelvin**

The following screenshot shows a text view display with Fahrenheit temperature units.

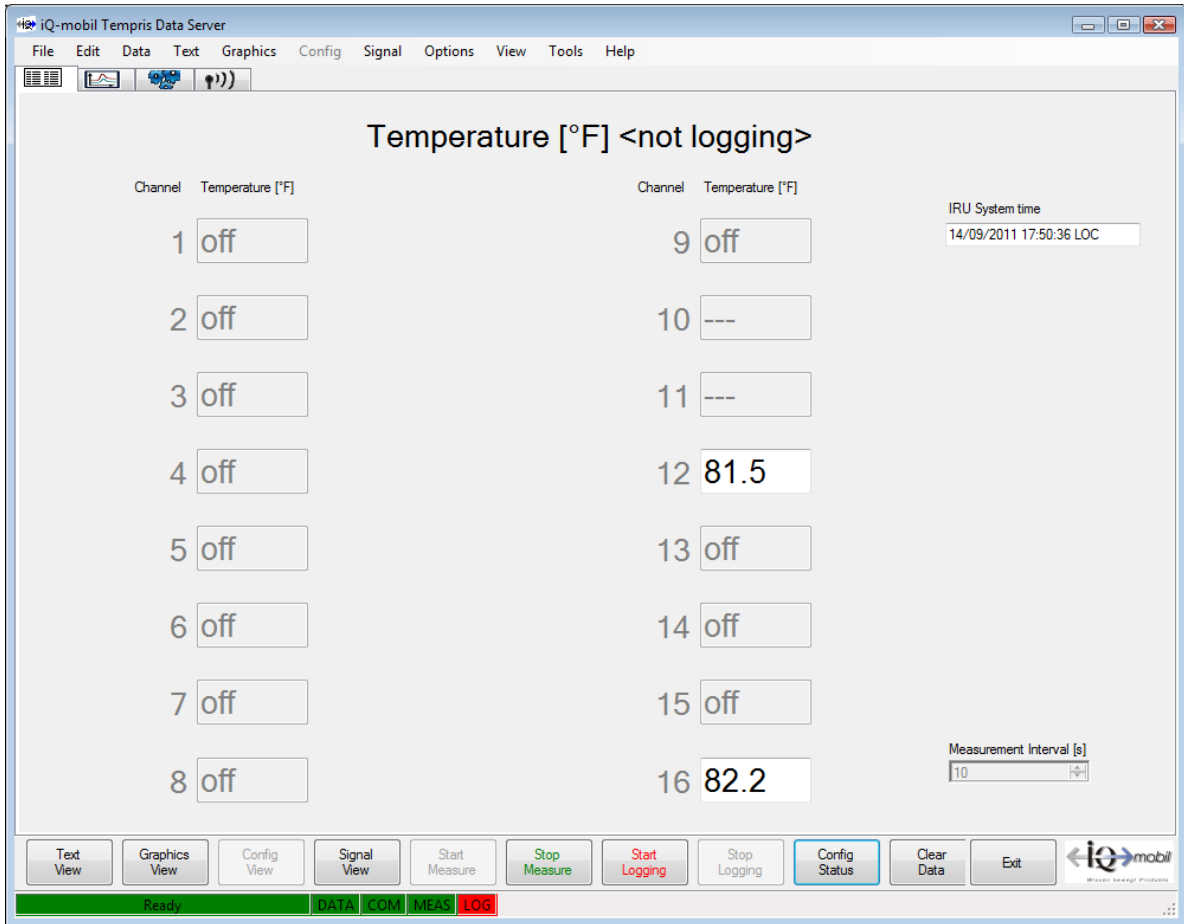

Figure 4-23: TDS Text View – Fahrenheit Temperature Display

4.8 Graphics View

The „**Graphics View**“ displays a plot data view of the monitored data. The graphics view can be activated through the **Graphics View** function from the **View** menu or by clicking the corresponding function index tab.

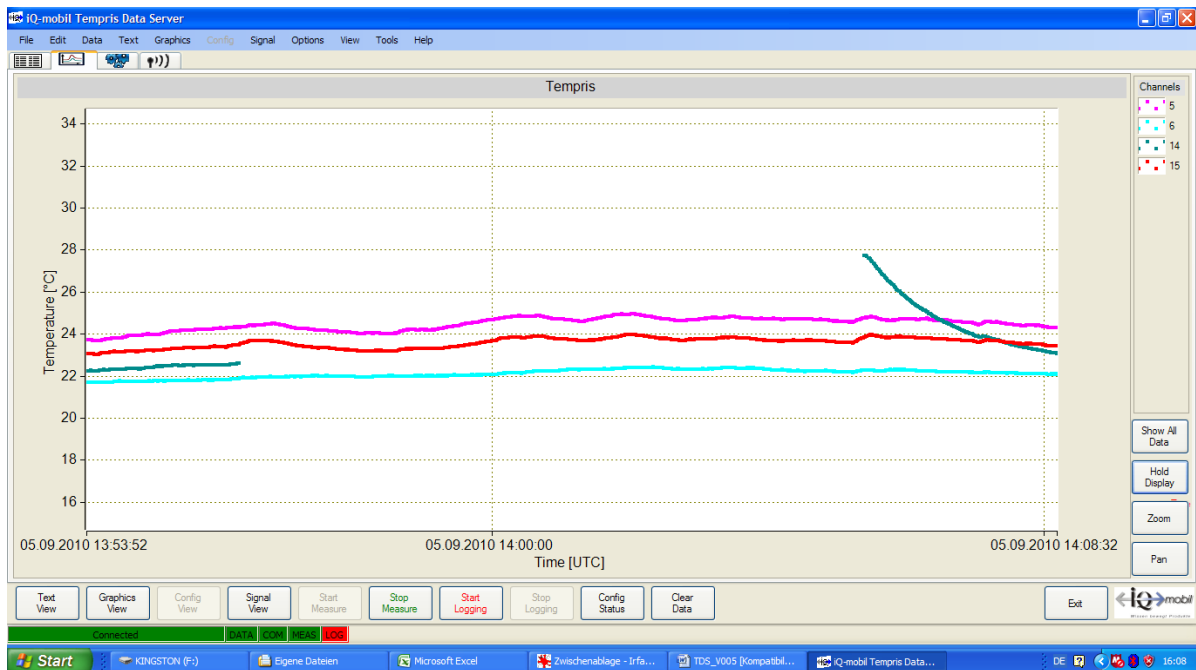

Figure 4-24: TDS Graphics View

The ordinate (y-axis) of the graph represents the temperature in the chosen temperature unit (Celsius, Fahrenheit, Kelvin). The abscissa (x-axis) represents the time in UTC (Coordinated Universal Time; "Time [UTC]") or local time ("Time [local]") as selected through **Options** – **Show Local Time**.

On default, the graphic output scales adaptively. I.e., the value range in the graphics view corresponds with the currently measured maximum and minimum temperature values. Optionally, a fixed scale can be selected.

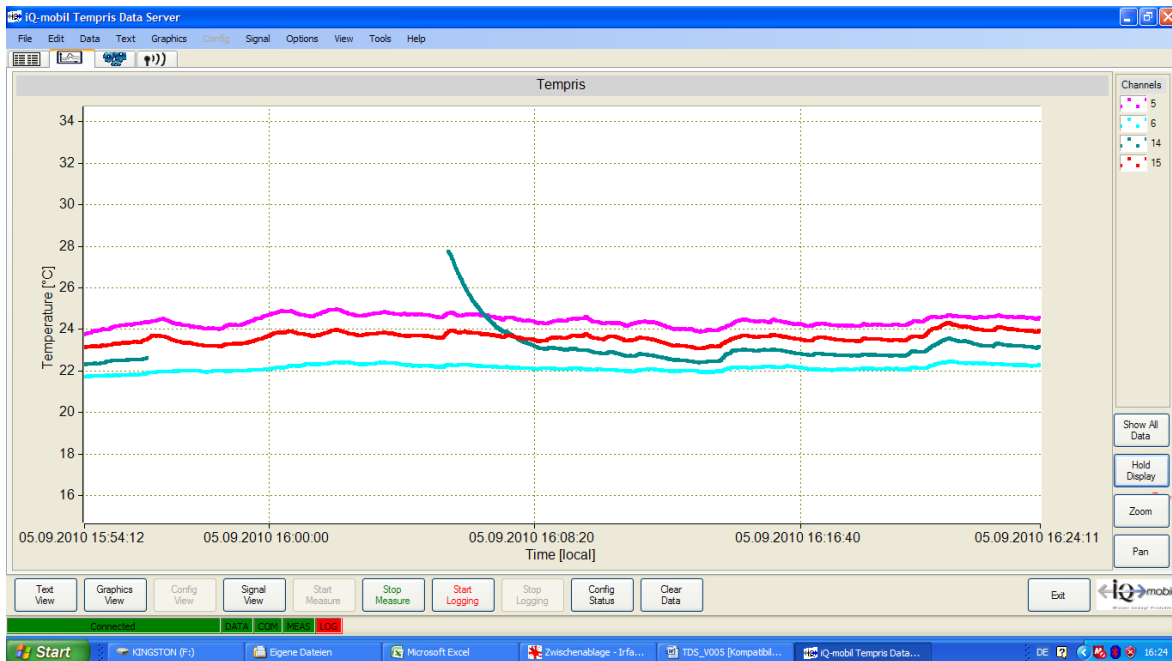

Figure 4-25: TDS Graphics View – Channel Toolbar

In the right upper “Channels” field of the graphics screen, buttons for the currently active channels are listed and assigned to the respective channel colour.

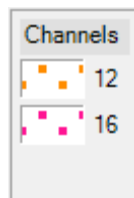

Figure 4-26: TDS Graphics View – Channel Buttons

You can toggle the visibility of channels in the graphics view by double-clicking the channel buttons. Right-clicking the channel buttons activates a channel button context menu for changing channel display parameters such as display colour, display of additional information, etc.

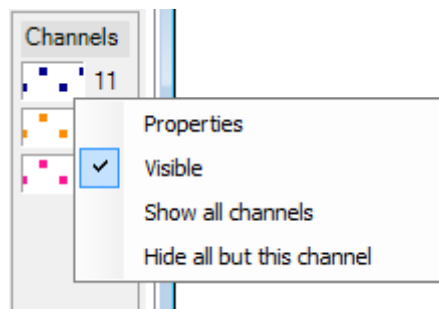

Figure 4-27: TDS Graphics View – Channel Button Context Menu

The **Properties** function of the channel button context menu activates a dialog for channel display settings where you can toggle the visibility of the selected channel and set channel display properties such as the colour, the "Point Style", the point "Width", the "Line-Style" and the line "Width" for both the temperature plot display and the secondary channel trace (signal quality "S/N" or antenna assignment; see below).

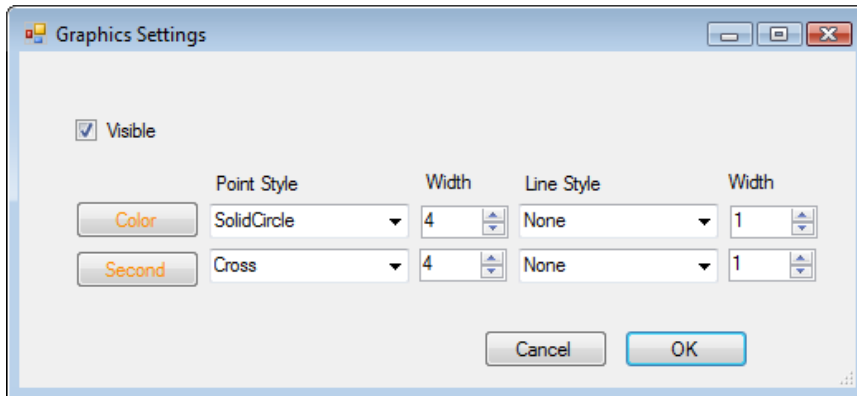

Figure 4-28: TDS Graphics View – Channel Display Settings

The **Hold Display** function is used to suspend (and resume) graphic updates (data recording keeps running in the background):



Figure 4-29: TDS Graphics View – Show All Data

The **Show All Data** function displays all data recorded since the start of the monitoring process (with compressed time axis if necessary).

Note

Show All Data can take a few moments to complete if the TEMPRIS DataServer holds a large amount of measuring data.

The **Hold Display** function resumes the real-time display (with data for the last 30 minutes being shown).

The graphics view also offers a marker function for displaying a cross-hair graphic cursor with a time-value pair at the selected position:

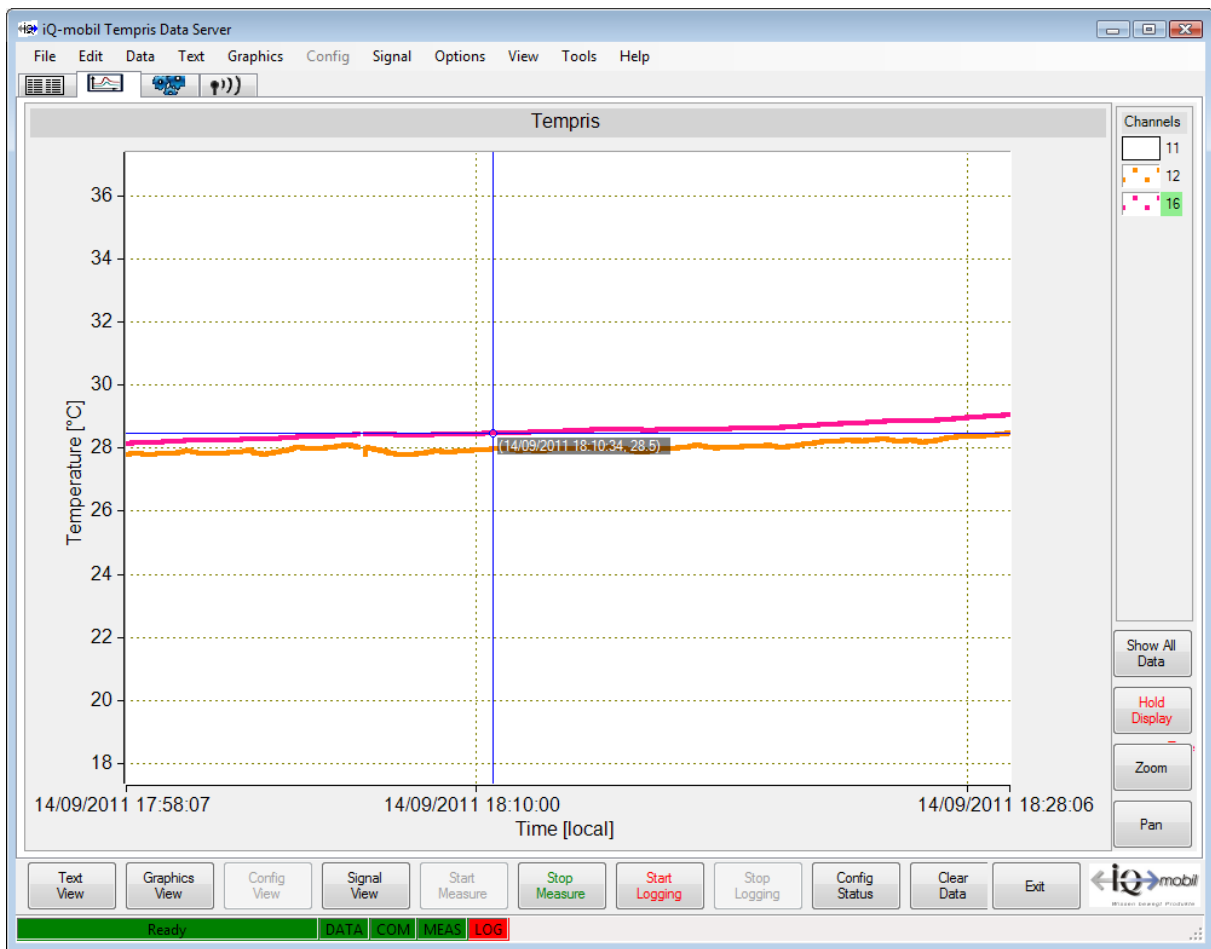

Figure 4-30: TDS Graphics View – Marker Function

It is recommended to use the marker function only while real-time display is suspended. Use **Hold Display** to suspend and resume real-time display.

The **Zoom** function can be used for interactively selecting a zoom window. It is recommended to use the **Zoom** function only while real-time display is suspended. Use **Hold Display** to suspend and resume real-time display.

The following screenshot illustrates a zoom window selection:

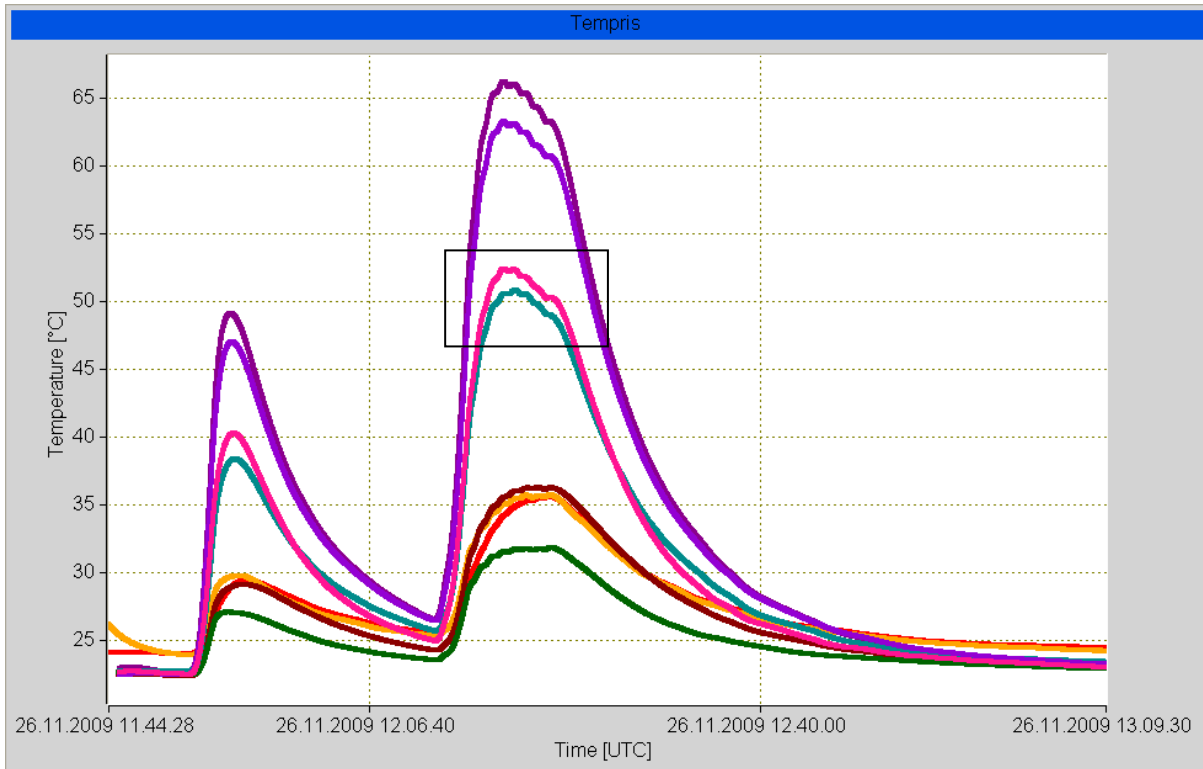

Figure 4-31: TDS Graphics View – Zoom Window Selection

The following screenshot shows the selected zoom window display:

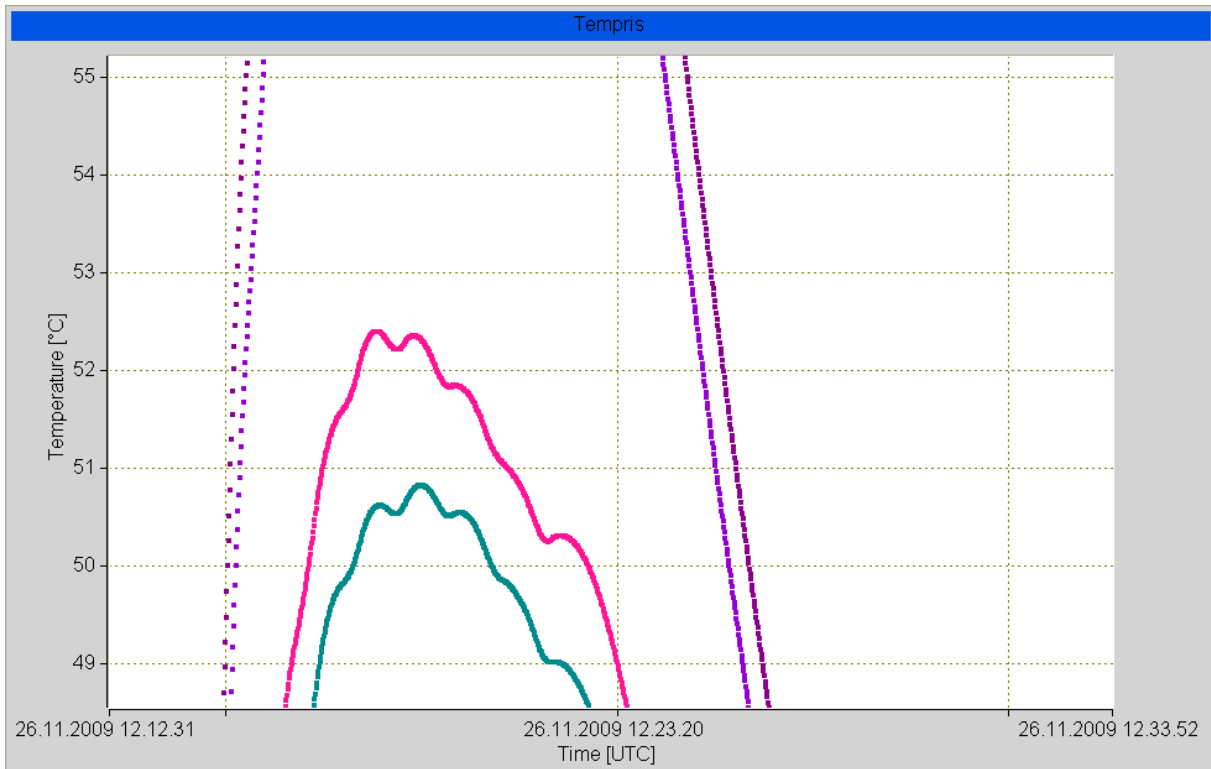

Figure 4-32: TDS Graphics View – Zoom Window Display

The **Pan** function can be used to move the graphic display in both x and y direction. It is recommended to use the **Pan** function only while real-time display is suspended. Use **Hold Display** to suspend and resume real-time display.

A right-click on the "Time" label activates a context menu with the following options:

- **Date / Time** - Display date and time
- **Time only** - Display time only
- **Zero-based time span** - Display relative time since the start of the measurement



Figure 4-33: TDS Graphics View – Time Label Settings

A right-click on the "Temperature" label activates a context menu with the following options:

- **Units** - Temperature units selection:
 - **Celcius**
 - **Fahrenheit**
 - **Kelvin**

- **Range** - Choice of ordinate scale:
 - **Automatic scaling** (adaptive)
 - **Manual scaling** (permanent, according to maximum/minimum value selections)

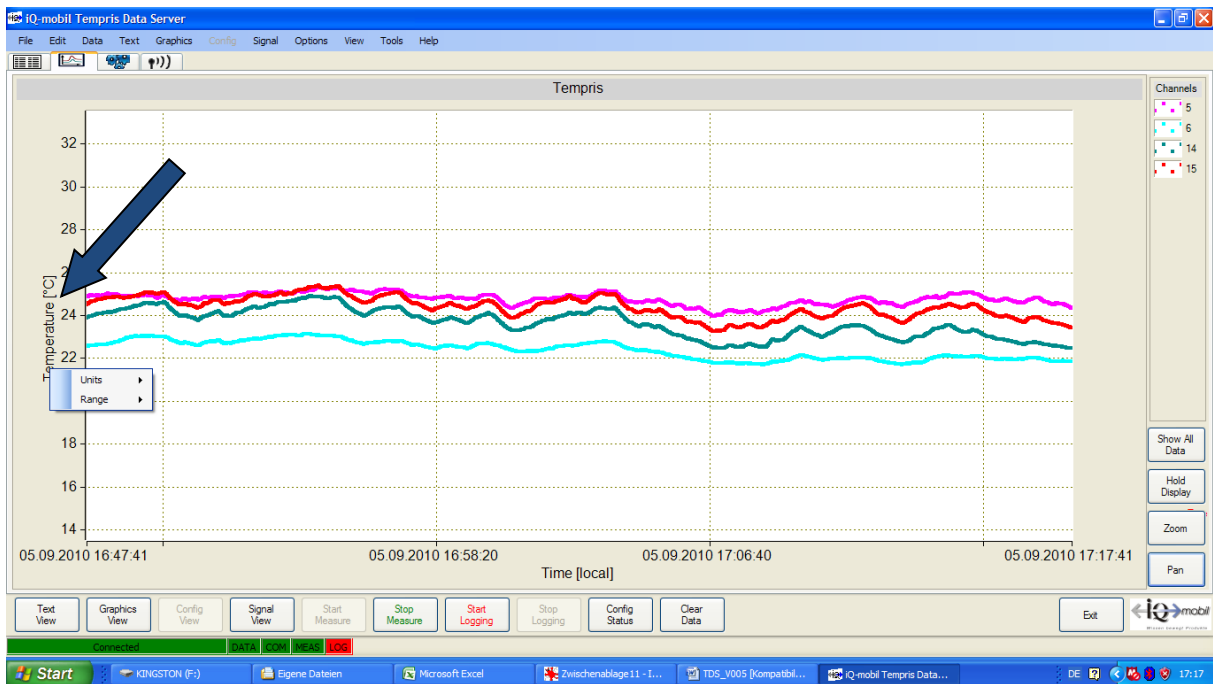

Figure 4-34: TDS Graphics View – Temperature Label Settings

A right-click anywhere in the graphics area activates the following context menu:

- **Show Second Trace** – options for displaying an additional data graph:
 - **None** – no additional data graph
 - **S/N** – display signal-to-noise ratio (signal quality; see below) data graph
 - **Antenna** – display assigned antenna data graph(s)

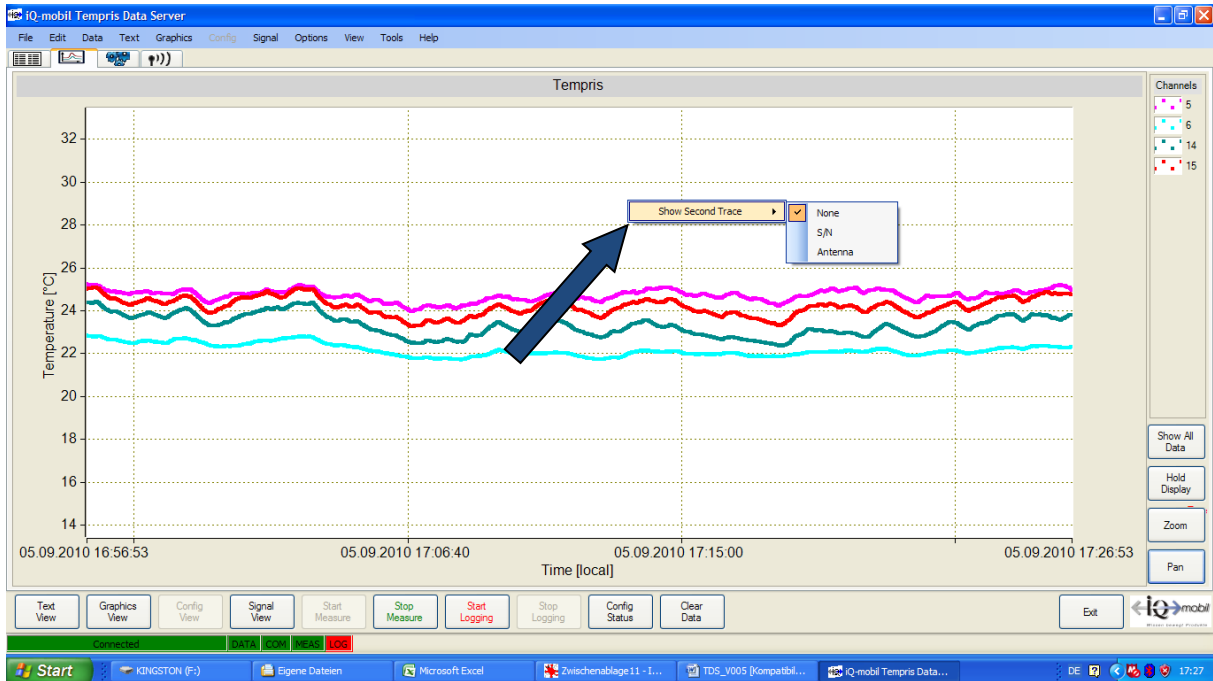

Figure 4-35: TDS Graphics View – Graphics Area Context Menu

The following screenshot shows a graphic view with **Show Second Trace** – **S/N** activated (see chapter 6.8 for more information on S/N):

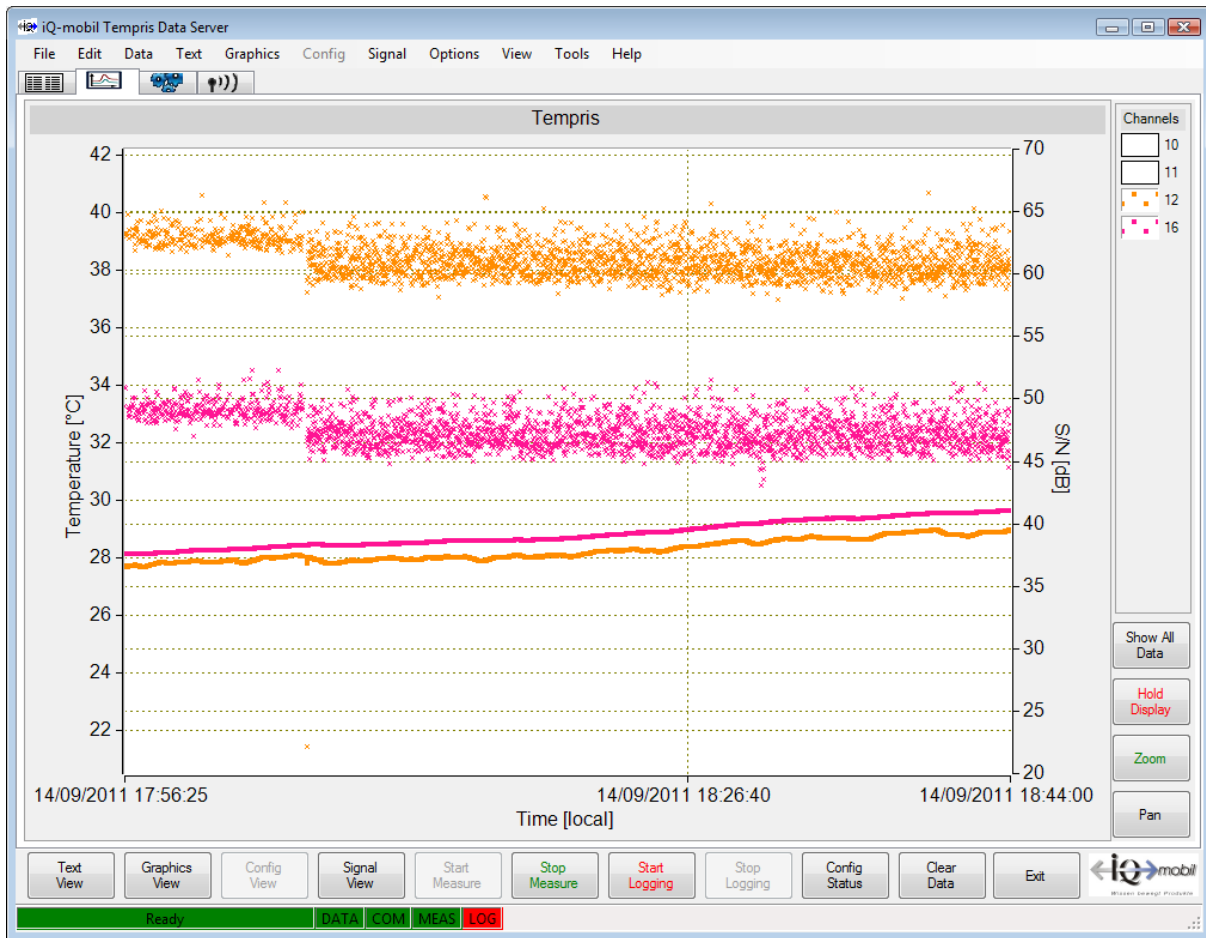

Figure 4-36: TDS Graphics View – Show Second Trace S/N

4.9 Signal View

In the “**Signal Strength**” tab of the Signal View, the current data quality of the incoming data is visualized. The data quality is displayed using S/N values (signal-to-noise ratio; spoken “S to N”), a logarithmic measure for the signal quality.

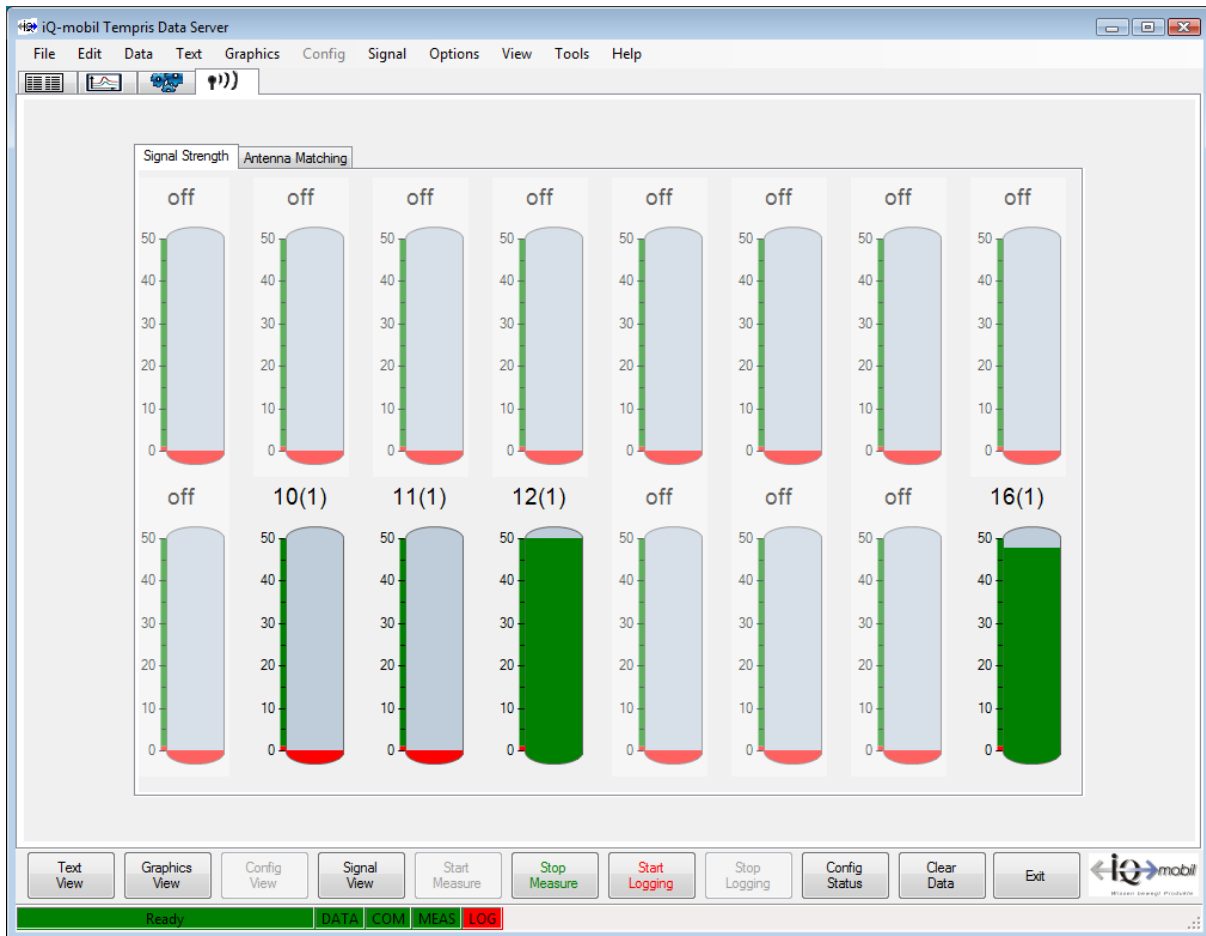

Figure 4-37: TDS Signal View – Signal Strength

The "Antenna Matching" tab of the Signal View displays indicators for channel to antenna matching quality.

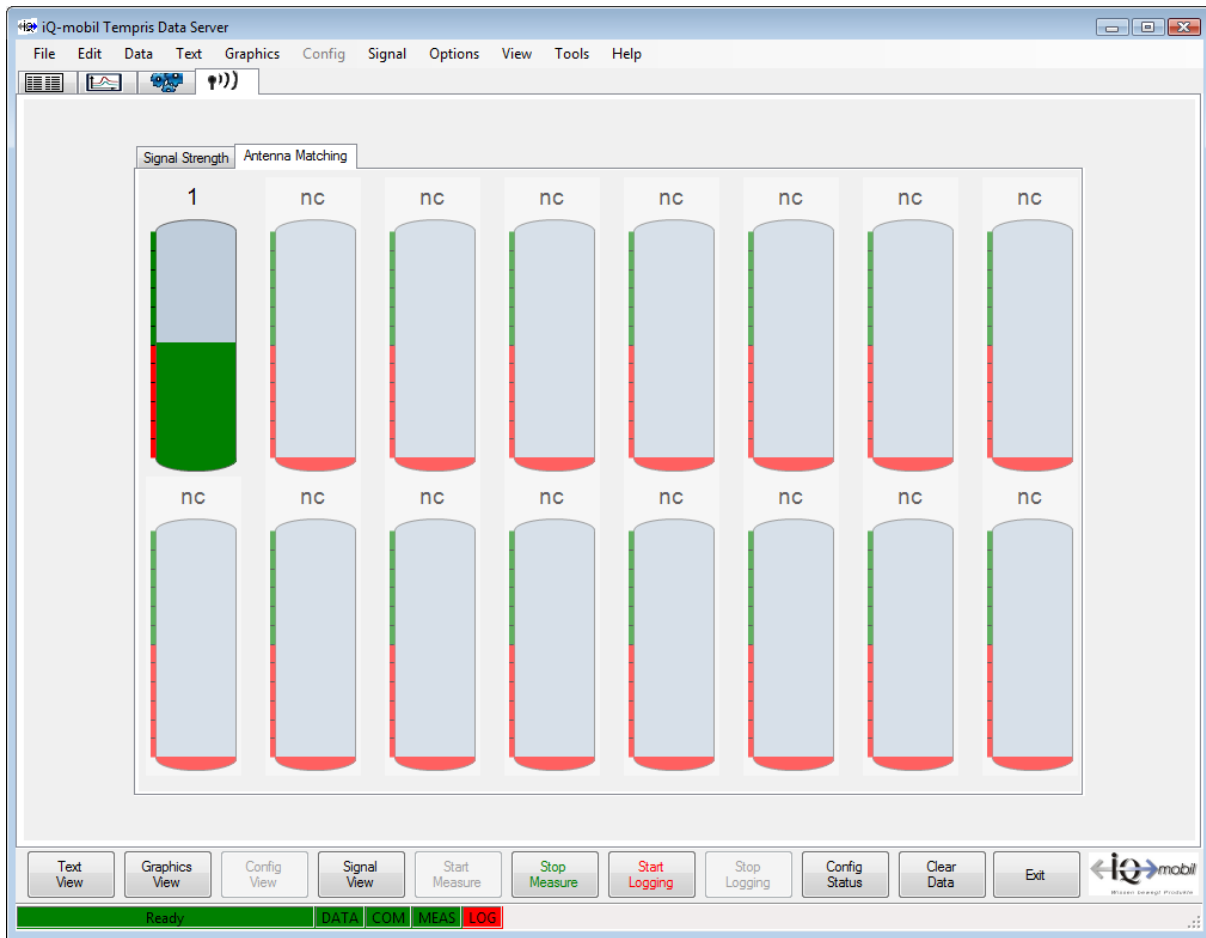

Figure 4-38: TDS Signal View – Antenna Matching

4.10 Clearing the Current Data Screen

The **Clear Data** command from the **Data** menu or the graphics view toolbar clears the current graphic screen and restarts graphic output and/or display without affecting any active data logging on the TEMPRIS interrogation unit.

4.11 Recording Incoming Measuring Data onto Log Files

The **Start Logging** and **Stop Logging** commands from the toolbar are used to activate and/or deactivate the recording of incoming measuring data onto a log file.

The **Start Logging** command activates a dialog for specifying the desired log file name:

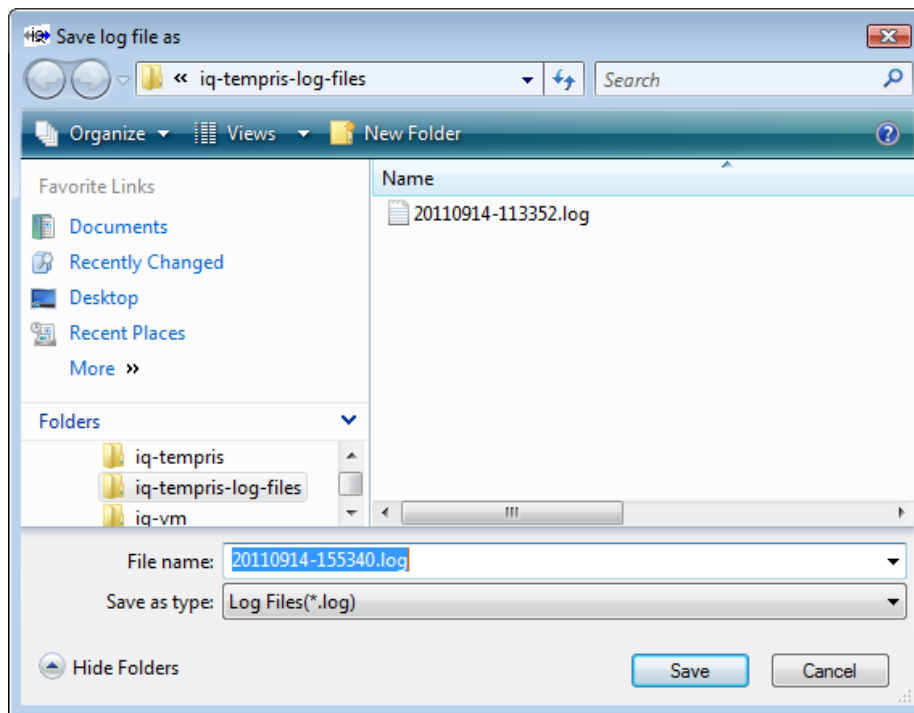

Figure 4-39: Start Logging - Log File Name Selection

Note

Please make sure to specify a non-existing log file name to prevent the **Start Logging** function from overwriting any existing log file with the same (default) log file name which previously may have been created with **Start Logging** and **Stop Logging** during the same TEMPRIS DataServer session.

After specifying a log file name, the following dialog for specifying log file information is activated:

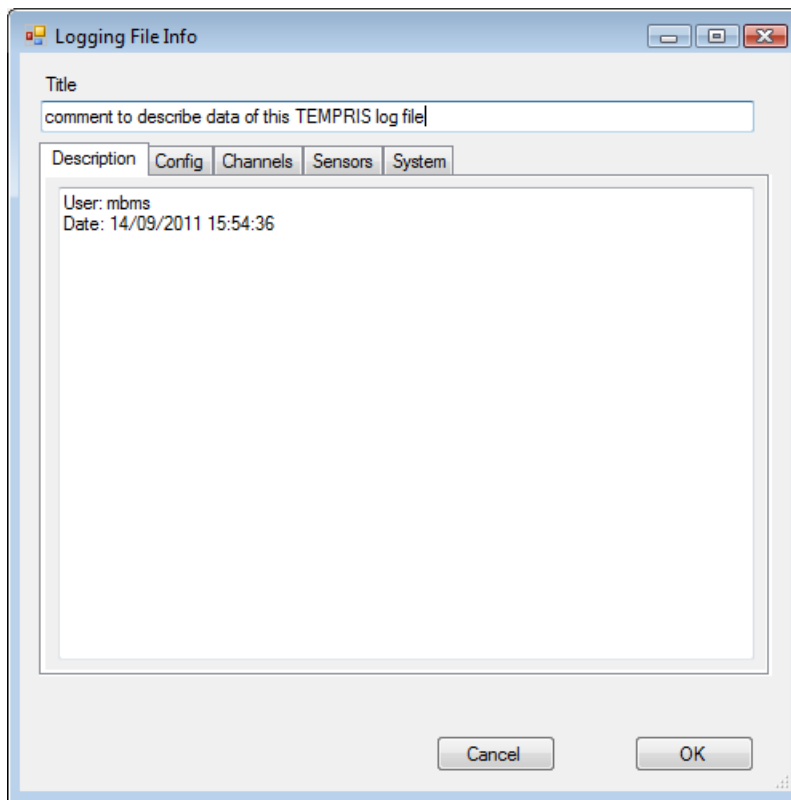

Figure 4-40: Start Logging – Log File Info

The **“Title”** input field allows for a title for the logged data to be entered. The **“Description”** text field allows for a descriptive text (notes, comments, etc.) for the logged data to be typed in. This information is permanently stored in the log file header of the log file and may be helpful when examining and/or processing the log file data at a later stage.

TEMPRIS log files can become very large (several 100 MB) depending on the duration of the measurement and/or the selected data rate. This may pose handling problems when processing such large log files on computers with limited processor capacity, main memory or hard disk space. We therefore recommend that you choose the data rate with this in mind and according to your actual time resolution requirements.

Log files can be exported to CSV (“Comma Separated Values”) files for subsequent processing in spread sheet applications such as Microsoft Excel.

Since the measuring data is stored internally within the program during a measuring run, a later permanent saving of data is also possible with the **File** – **Save Current Data** function.

The **Save Current Data** function saves the currently displayed data to a log file (`/*.log`). The **Save Current Data** function offers you the choice between **Signal Only** and **Signal Details**. The **Signal Only** option saves temperature data only. The **Signal Details** option saves the temperature data and additional data such as S/N (signal-to-noise ratio, signal quality) values.

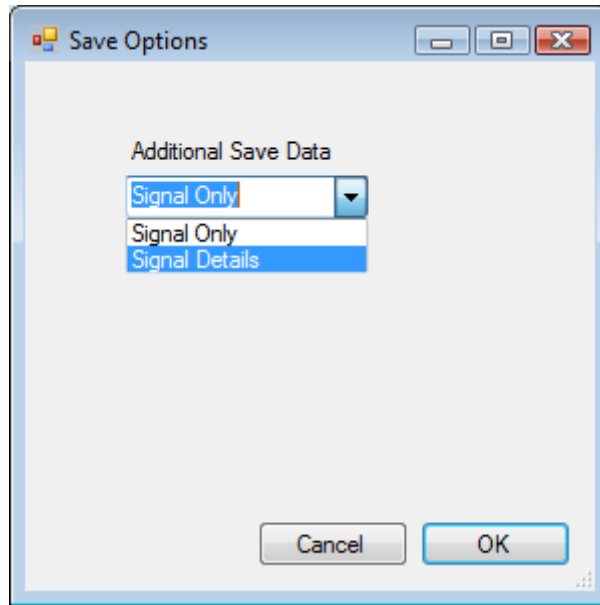

Figure 4-41: Save Current Data

Please note that cached data is cleared if you use either the **Clear Data** command (from the **Data** menu or the graphics view) or the **Exit** command (from the **File** menu or the toolbar). At the beginning of a measurement, you should take the precaution of using the **Start Logging** command to generate a log file as this provides a backup in case you accidentally use **Clear Data** or **Exit** without having saved your measurement data.

4.12 Print and Plot Output

The TEMPRIS DataServer program provides a number of functions for generating print and plot outputs.

The **File** - **Page Setup** function activates a dialog for selecting printer settings such as paper size, paper source/feed, page orientation (**Portrait** or **Landscape**) and page/print margins:

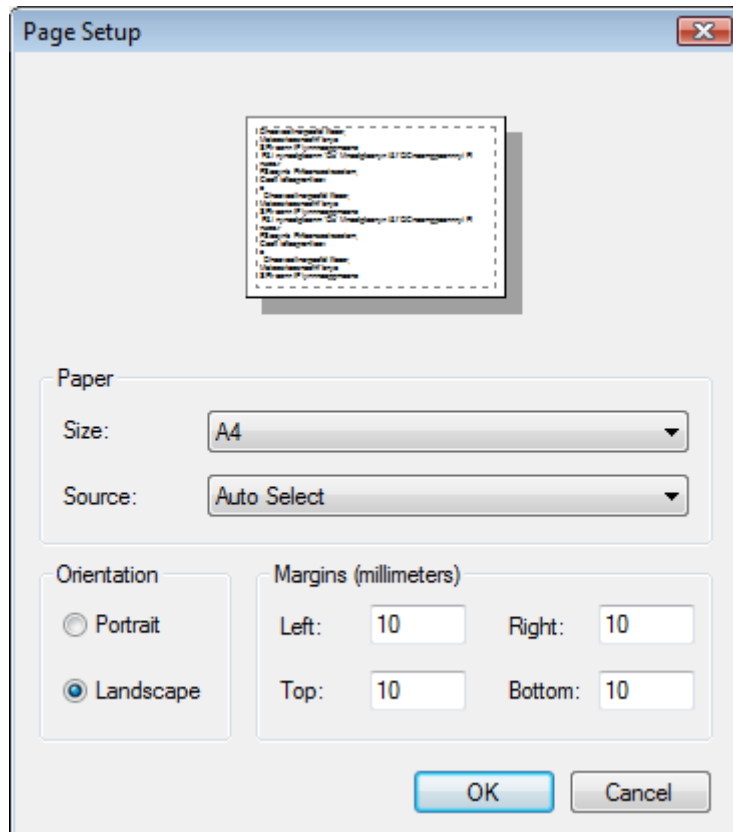

Figure 4-42: Print Page Setup

The **File** - **Print Preview** - **Current View** function displays preview of the expected print result for the total current screen. This function is available in all data view modes.

The **File** - **Print Preview** - **Graphics** function displays a preview of the expected print result of the current graphics area without command / status bar. This function is only available in graphics view mode.

The **File** - **Print** - **Current View** function prints the total current screen. This function is available in all data view modes.

The **File** - **Print** - **Graphics** function prints the current graphics area without command and status bar. This function is only available in only in graphics view mode.

4.13 Loading Log Files for Offline Data Visualization

The **File** - **Load Log File** function can be used to load log files from previous TEMPRIS measurements for offline processing (visualization, measurement with cross hairs, detail view with zoom function, documentation with "Print", etc.). If necessary, multiple log files can be superimposed.

The **Data** - **Loaded Log File Info** function displays the names of the loaded log files together with start and end time of the loaded data and an indication of the activated channels:

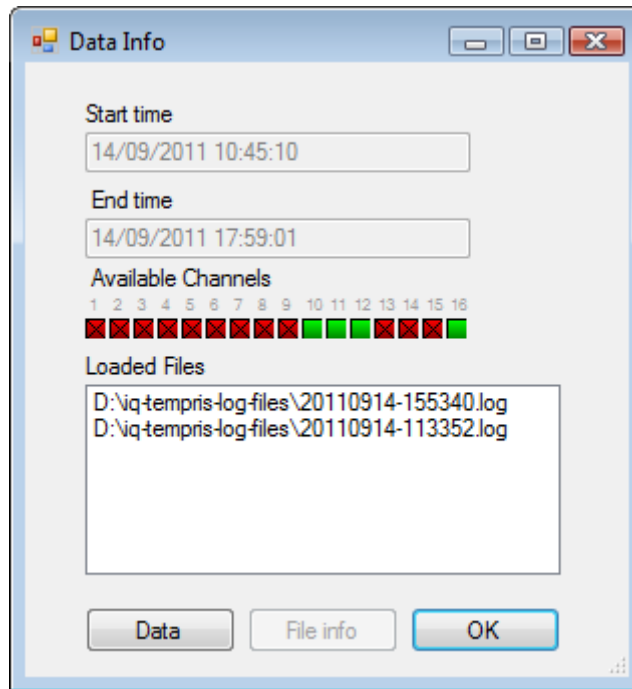
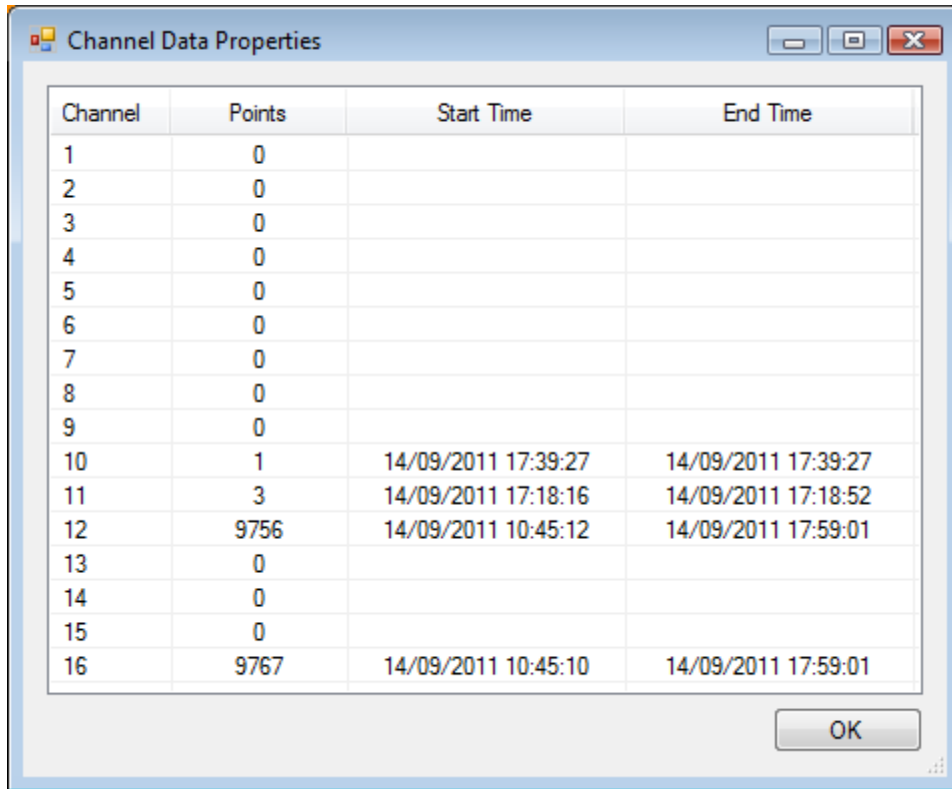

Figure 4-43: Loaded Log File Info

The **Data** button in the **Loaded Log File Info** dialog activates a channel data properties dialog with additional log file information about stored channels, data volume, and recording time.



Channel	Points	Start Time	End Time
1	0		
2	0		
3	0		
4	0		
5	0		
6	0		
7	0		
8	0		
9	0		
10	1	14/09/2011 17:39:27	14/09/2011 17:39:27
11	3	14/09/2011 17:18:16	14/09/2011 17:18:52
12	9756	14/09/2011 10:45:12	14/09/2011 17:59:01
13	0		
14	0		
15	0		
16	9767	14/09/2011 10:45:10	14/09/2011 17:59:01

Figure 4-44: Loaded Log File Info - Data

Note

The TEMPRIS interrogation unit needs not be connected for the **Load Log File** function to work. I.e., you can use the TEMPRIS DataServer software on a PC or laptop without a connection to a TEMPRIS interrogation unit to load and analyse TEMPRIS measurement data from a previously stored TEMPRIS log file. We also make sure that the TEMPRIS log file format is forward compatible. This means that your TEMPRIS DataServer software can load TEMPRIS log files which were saved with older TEMPRIS DataServer versions.

4.14 Data Export to CSV

The **Data** - **Export Current Data to CSV** function is used to export the currently loaded measuring data to a CSV file (CSV = "Comma Separated Values") for further processing in spread sheet applications such as Microsoft Excel.

Export Current Data to CSV generates two CSV file columns for each active channel/sensor. The first of these columns contains the timestamp (in country-specific format), and the second column contains the temperature value in country-specific decimal notation. Up to 16 channels are exported with each channel having its own timestamp column.

The following screenshot shows a Microsoft Excel session with an imported TEMPRIS CSV file.

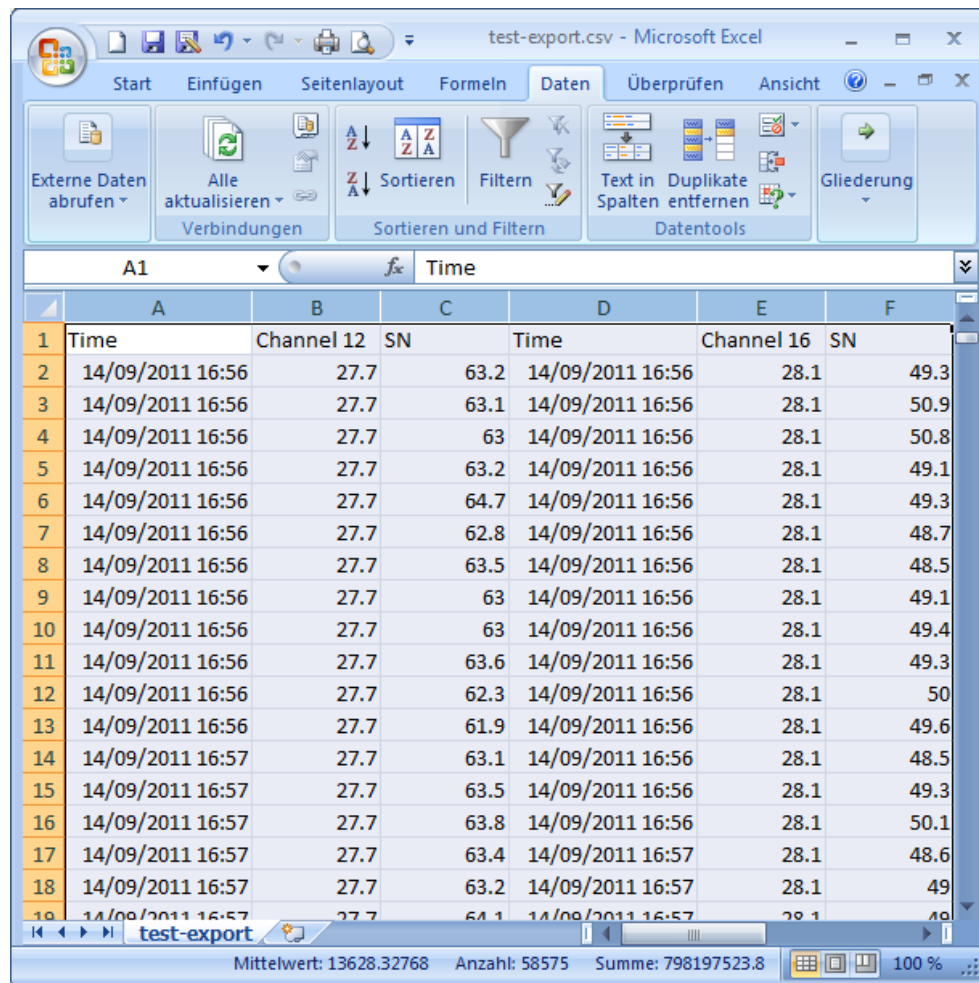

Figure 4-45: TEMPRIS CSV Data in Microsoft Excel

The **Export Current Data to CSV** function exports date/time values and numerical values using the format which is currently activated through your Windows **Control Panel** - **Regional and Language Options** settings. Certain Microsoft Excel versions are limited to a maximum of 32000 data rows per spread sheet. To overcome this potential problem you can either log your TEMPRIS data at a reduced data rate (see 6.5 Configuring the system settings, "Measurement Interval(s)") or create appropriate excerpts from the data stock using the **File** - **Save Current Data** function.

The TEMPRIS interrogation unit needs not be connected for the **Export to CSV** function to work. I.e., you can use the TEMPRIS DataServer software on a PC or laptop without a connection to a TEMPRIS interrogation unit to load TEMPRIS measurement data from a previously stored TEMPRIS log file with the **Load Log File** function and export this data to a CSV file with the **Export to CSV** function.

For an easier handling of large log files, you can use the compression tools **Compress Log file** and **Decompress Log file** from the **Tools** menu.

4.15 Copying Screens to the Windows Clipboard

The commands **Copy Graphics**, **Copy Signal Info** and **Copy Current View** commands from the **Edit** menu can be used to copy the corresponding screens as bitmap image (without the actual data) to the Windows Clipboard for further processing (pasting/inserting) in word processor and desktop publishing applications such as Microsoft Word.

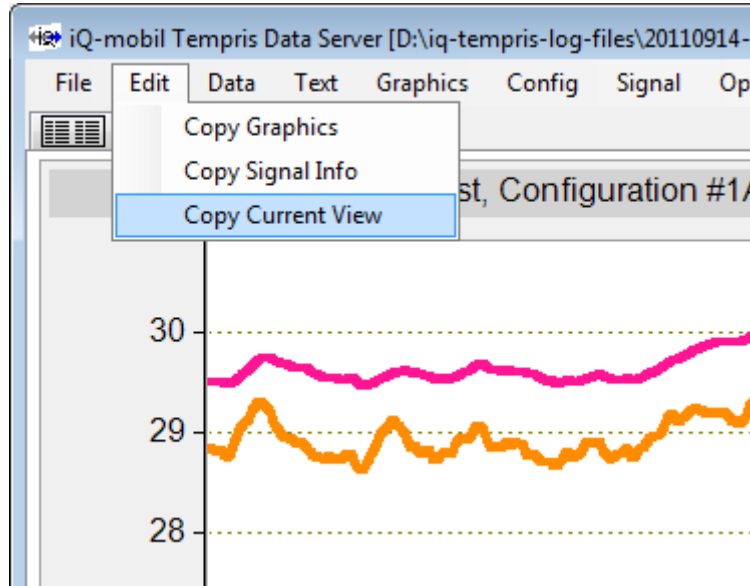

Figure 4-46: Copy Screen to Clipboard

4.16 Retrieving the Current Configuration Settings

The **Config Status** command toolbar button retrieves and displays the current TEMPRIS DataServer and TEMPRIS interrogation unit configuration status. The **Config Status** command can only be activated if a connection to a TEMPRIS interrogation unit is active.

The **Print Config Document** button in the **Config Status** window can be used to print the configuration status.

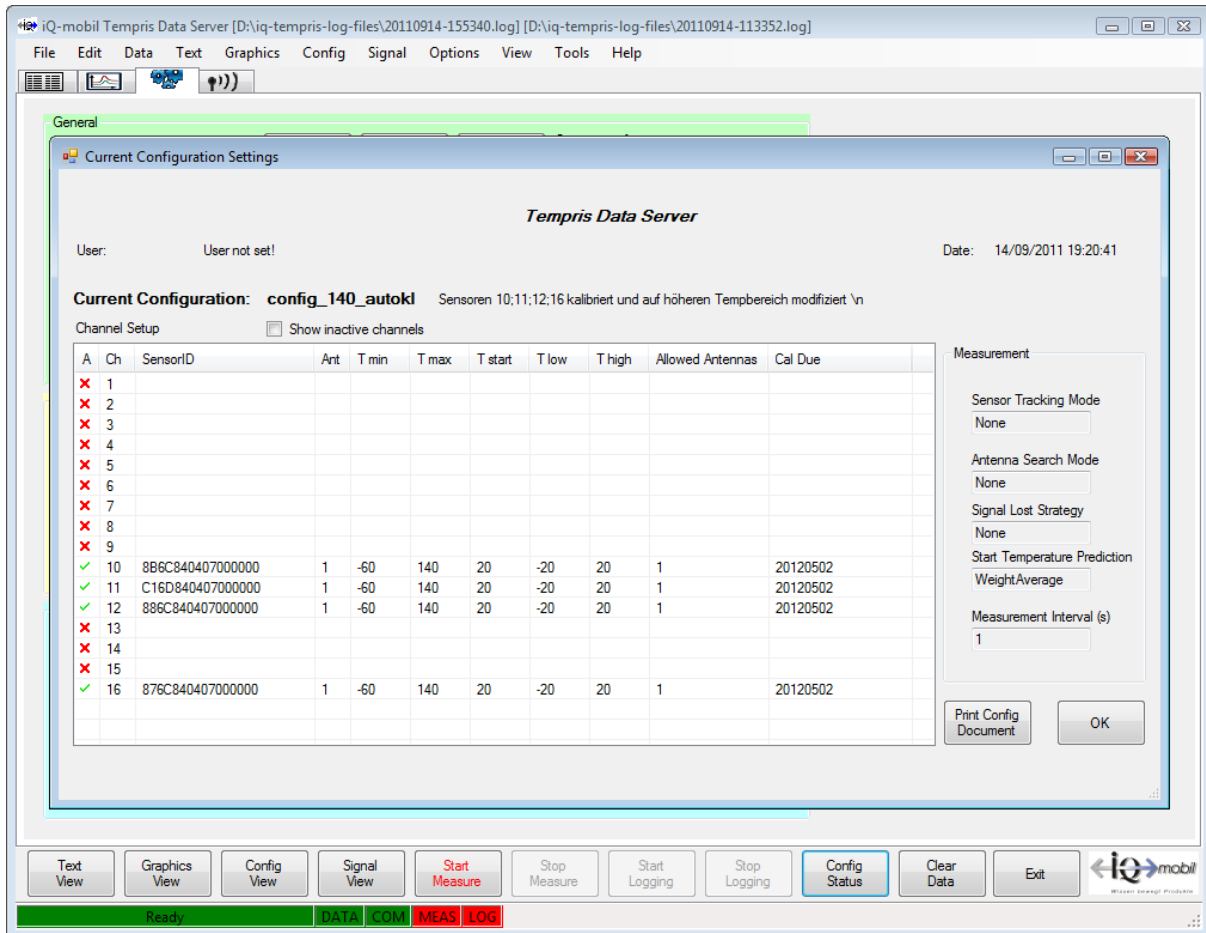

Figure 4-47: Current Configuration Settings

4.17 Exiting the TEMPRIS DataServer

The **Exit** command from the toolbar or the **File** menu is used to terminate the TEMPRIS DataServer session.

Note

Exiting the TEMPRIS DataServer software does not affect the activities of the TEMPRIS interrogation unit. I.e., the TEMPRIS interrogation unit keeps supplying a connected PLC / SCADA system with data, even though the TEMPRIS DataServer program which started the measurement on that TEMPRIS interrogation unit has been closed.

5 TEMPRIS Options

5.1 Modbus TCP/IP Interface

The TEMPRIS system comes with a Modbus TCP/IP interface. The TEMPRIS Modbus TCP/IP interface is integrated to the TEMPRIS IRU-2 interrogation unit and can be configured with the TEMPRIS DataServer software.

The TEMPRIS Modbus TCP/IP interface allows for TEMPRIS data to be transmitted over 4-20mA or 0-20mA current loops to Programmable Logic Controllers (PLCs) for process-control use.

The following block diagram shows a typical setup of a TEMPRIS Modbus TCP/IP to PLC interface.

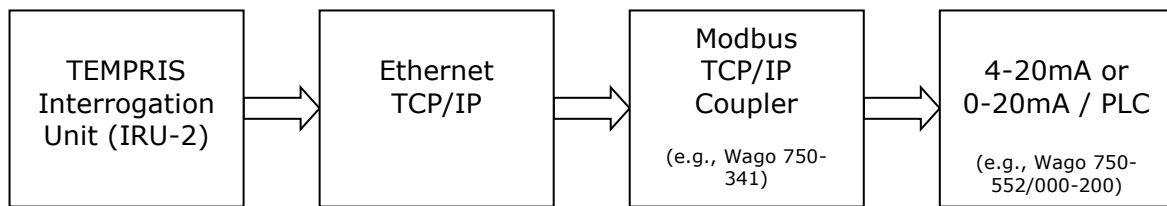

Figure 5-1: TEMPRIS Modbus TCP/IP to PLC Interface Setup

The following figure illustrates the principle of the TEMPRIS temperature sensor data and sensor status output to the PLC. The TEMPRIS sensor temperature value is transmitted with "Write Single Register" (function code FC6) or "Write Multiple Registers" (function code FC16) to the Modbus register. The TEMPRIS sensor status flag ("Sensor missing/not found") is transmitted with "Write Single Coil" (function code FC5) or "Write Multiple Coils" (function code FC15) to the Modbus "coil".

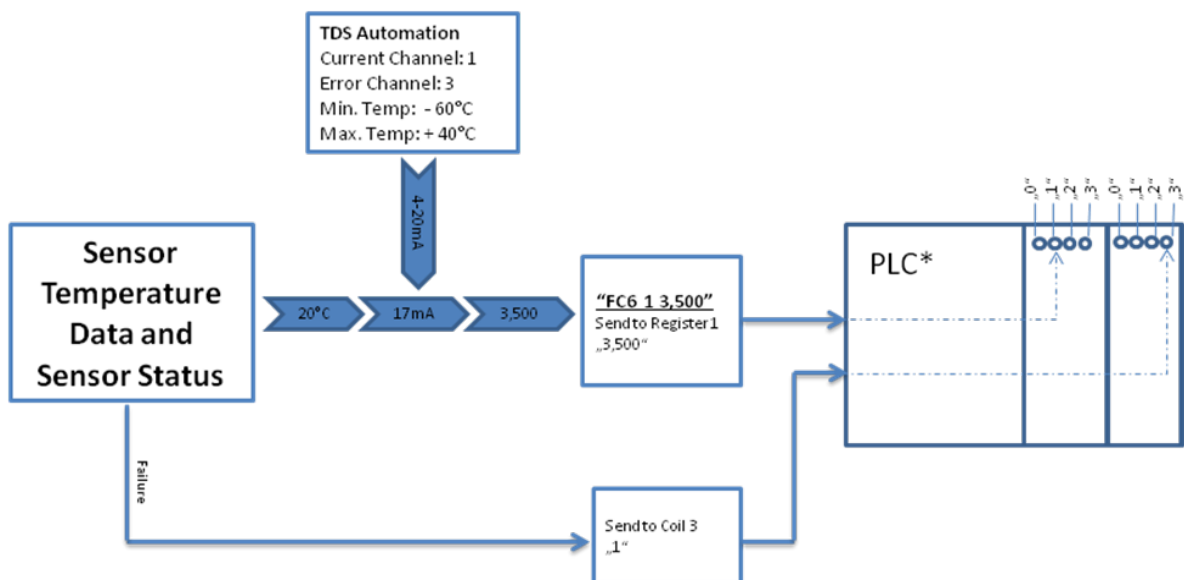

Figure 5-2: TEMPRIS Sensor Data and Sensor Status Output to PLC

5.1.1 TEMPRIS Modbus TCP/IP Interface Setup

General Modbus interface settings are carried out through the TEMPRIS DataServer "Automation Setup" dialog which can be activated with the **Config** - **System** - **Automation** function. The "Automation Setup" dialog provides controls for:

- setting the Modbus "IP Address",
- specifying the "Number of Digital Outputs" for transmitting TEMPRIS status flags to Modbus "Coils",
- specifying the "Number of Current Outputs" for transmitting temperature values to Modbus "Registers",
- enabling/activating the TEMPRIS Modbus TCP/IP interface.

The following figure shows the "Automation Setup" dialog. When pressing the **OK** or **Apply** button, the "Automation Setup" interface configuration is not only activated but also saved to the TEMPRIS interrogation unit for future use.

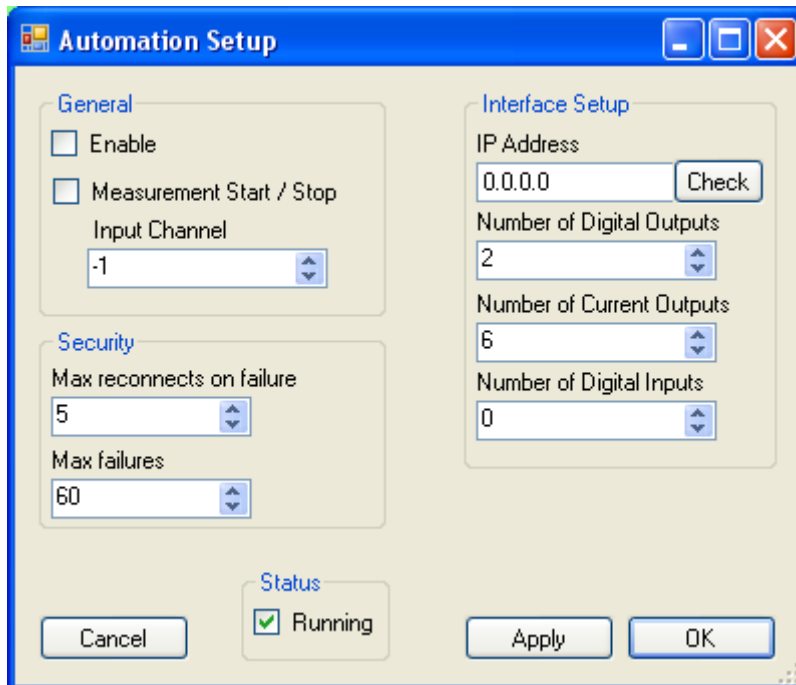

Figure 5-3: TEMPRIS DataServer Config – System – Automation

5.1.2 TEMPRIS Modbus TCP/IP Channel Configuration

The "Automation" tab in the **Channel Properties** dialog of the TEMPRIS DataServer is used for the configuration of channel-specific Modbus outputs. The **Channel Properties** dialog for a specific TEMPRIS channel is activated by clicking the channel button in the "Channel / Antenna Configuration" block of the TEMPRIS DataServer "Config View".

Channel Properties dialog controls:

- **"Current Output Index"**
Sets the Modbus "Register" for transmitting the channel/sensor temperature values. The "Current Output Index" is zero-based and limited by the "Number of Current Outputs" specified through "Automation Setup" (see above).
- **"T min" and "T max"**
Specifies the channel temperature range for the "Current Output Index" to be mapped to the 4-20mA current loop range.
(Typical setting for lyophilisation processes: $T_{\min} = -60^{\circ}\text{C}$; $T_{\max} = 40^{\circ}\text{C}$)
- **"T error"**
Specification of an error temperature value to be transmitted if no valid channel temperature value is available.
- **"Error Output Index"**
Sets the Modbus "Coil" for transmitting "Sensor missing / not found" status flags. The "Error Output Index" is zero-based and limited by the "Number of Digital Outputs" specified through "Automation Setup" (see above).
- **"4-20mA"**
Current loop range selection. Tick "4-20mA" box for 4-20mA range, or leave box unticked for 0-20mA range.

The following figure displays the "Automation" tab of the Channel Properties dialog. When pressing the **OK** or **Apply** button, the "Automation" channel properties are not only activated but also saved to the TEMPRIS interrogation unit for future use.

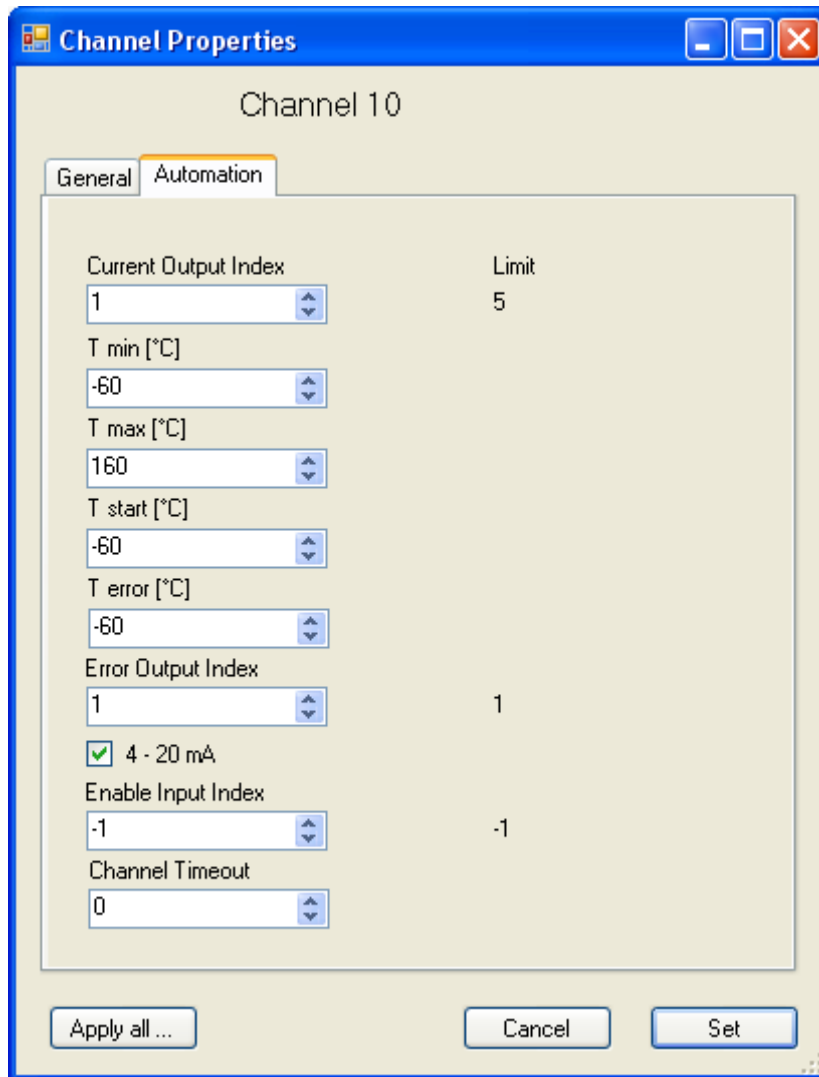

Figure 5-4: TEMPRIS DataServer Channel Properties - Automation