

THALES

OPERATION AND INSTALLATION MANUAL AHV1600 RADAR ALTIMETER SYSTEM

TRANSMITTAL SHEET

TO: HOLDERS OF OPERATION AND INSTALLATION MANUAL P/N: 36719226-AB, revision No. 1, dated NOV 25/09 is attached and covers all components held by every operator.

P/N: 36719226-AB.

The OIM revision No. 1, dated NOV 25/09 is attached and covers all components held by every operator.

FILING INSTRUCTIONS

Revision 1 replaces original issue.

Original issue is deleted.

HIGHLIGHTS:

To correct the OIM P/N: 36719226-AA Original issue.

THALES

OIM

AHV1600 SYSTEM

THIS PAGE INTENTIONALLY LEFT BLANK

THALES

THALES Communications

**OPERATION
AND
INSTALLATION MANUAL**

**AHV1600
Radar Altimeter System**

ORIGINAL ISSUE : July 16/09
REF : 36719226-AB
REVISION No : 01

TP Page 1/2
Nov 25/09

THALES

THALES Communications

**OIM
AHV1600-SYSTEM**

RECORD OF REVISIONS

REVISION N°	REVISION DATE	INSERTION		REVISION N°	REVISION DATE	INSERTION	
		DATE	BY			DATE	BY
01	2009/11/25						

THALES

THALES Communications

**OIM
AHV1600-SYSTEM**

THALES

THALES Communications

**OIM
AHV1600-SYSTEM**

SERVICE BULLETIN LIST

SERVICE BULLETIN N°	REVISION N°	REVISION DATE	SUBJECT

THALES

THALES Communications

**OIM
AHV1600-SYSTEM**

LIST OF EFFECTIVE PAGES

SUBJECT	PAGE	DATE	SUBJECT	PAGE	DATE	
Title Page	R 1	NOV 25/09		105	JULY 16/09	
	2	BLANK		106	JULY 16/09	
Record of Revisions	R 1	NOV 25/09		107	JULY 16/09	
	2	BLANK		108	JULY 16/09	
Record of Temporary Revisions	1	JULY 16/09		109	JULY 16/09	
	2	BLANK		110	JULY 16/09	
Service Bulletin List	1	JULY 16/09		111	JULY 16/09	
	2	BLANK		112	JULY 16/09	
List of Effective Pages	R 1	NOV 25/09		113	JULY 16/09	
	2	BLANK		114	JULY 16/09	
Table of Contents	1	JULY 16/09		115	JULY 16/09	
	2	JULY 16/09		116	JULY 16/09	
Table of Figures	1	JULY 16/09		117	JULY 16/09	
	2	BLANK		118	JULY 16/09	
Introduction	1	JULY 16/09		119	JULY 16/09	
	2	JULY 16/09		120	JULY 16/09	
	3	JULY 16/09		121	JULY 16/09	
	4	JULY 16/09		122	JULY 16/09	
Identification sheet	1	JULY 16/09		123	JULY 16/09	
	R 2	NOV 25/09				
General	1	JULY 16/09		Installation	201	JULY 16/09
	2	JULY 16/09		202	JULY 16/09	
	3	JULY 16/09		203	JULY 16/09	
	4	JULY 16/09	204	JULY 16/09		
Presentation	101	JULY 16/09	205	JULY 16/09		
	102	JULY 16/09	206	JULY 16/09		
	103	JULY 16/09	207	JULY 16/09		
	104	JULY 16/09	208	JULY 16/09		
			209	JULY 16/09		
			210	JULY 16/09		
			211	JULY 16/09		
			Operation	301	JULY 16/09	
			302	JULY 16/09		

THALES

THALES Communications

**OIM
AHV1600-SYSTEM**

TABLE OF CONTENTS

	PAGES
INTRODUCTION.....	1
1. GENERAL INFORMATION	1
2. BLOCK PAGE NUMBERS FOR SECTIONS.....	1
3. UPDATING	1
4. ADVISORIES.....	2
A. SAFETY INSTRUCTIONS / ELECTROSTATIC DISCHARGE PRECAUTIONS.....	2
B. SHORT - CIRCUIT PRECAUTIONS.....	2
5. UNCOMMON ABBREVIATIONS AND ACRONYMS	3
GENERAL.....	1
1. AHV1600 RADAR ALTIMETER MAIN FUNCTION.....	1
2. AHV1600 BASIC PRINCIPLE.....	1
3. BUILT IN TEST FUNCTION.....	3
A. POWER-UP BUILT IN TEST (PBIT).....	3
B. INITIATED BUILT IN TEST (IBIT)	3
C. CONTINUOUS BUILT IN TEST (CBIT)	3
4. AIRCRAFT INTERFACE	3
PRESENTATION.....	101
1. AHV1600 RADAR ALTIMETER SYSTEM GENERAL DESCRIPTION.....	101
2. AHV1600 TRANSCEIVER.....	102
A. EXTERNAL CHARACTERISTICS.....	103
B. INTERNAL SUB-ASSEMBLIES	106
C. FUNCTIONAL CHARACTERISTICS	106
3. OPERATIONAL INTERFACES	117
A. POWER SUPPLY	117
B. DIGITAL ARINC429 INTERFACE	117
C. AID SIGNALS INTERFACE	118
D. ENVIRONMENTAL CONDITIONS	119
E. IN FLIGHT CONDITIONS	120
4. ANTENNA ANT-140A.....	120
A. GENERALITIES ON ANTENNA ANT-140A	120
B. PHYSICAL CHARACTERISTICS	120
C. FUNCTIONAL CHARACTERISTICS.....	122
5. COAXIAL CABLES LENGHT	122
INSTALLATION	201
1. GENERAL CONDITIONS.....	201
A. POWER SUPPLY	201
B. LOCATION.....	201
C. WATER, SAND, AND DUST TIGHTNESS.....	201
D. MOUNTING.....	201
E. INSTALLATION CONDITIONS.....	201
2. STEP BY STEP TRANSCEIVER INSTALLATION.....	202
A. CHOICE OF ANTENNAE LOCATION	203
B. ANTENNA MOUNTING	204
C. CONNECTION.....	205
3. VERIFICATION.....	205
A. GROUND TESTS	205
B. IN FLIGHT TESTS	205

	PAGES
4. FUNCTIONAL CONNECTIONS WITH RELATED EQUIPMENT	205
A. INTERFACES CONNECTIONS	205
B. GROUNDING AND BONDING	206
C. COOLING OF THE EQUIPMENT	207
D. HANDLING	207
5. EQUIPMENT INPUTS / OUTPUTS	207
A. MAIN CONNECTOR J1	207
B. RX/TX ANTENNA	210
OPERATION	301
1. RADAR ALTIMETER ENERGIZATION	301
2. FUNCTIONAL TEST	301
3. NORMAL OPERATING MODE	301
4. OUT OF RANGE OPERATION	301
5. FAILURE MODE	301
6. DEFAULT OPERATING INSTRUCTIONS	302
7. OPERATIONAL LEVEL MAINTENANCE TASK	302
A. REMOVING THE TRANSCEIVER	302
B. INSTALLING THE SPARE TRANSCEIVER	302

TABLE OF FIGURES

	PAGES
Figure 1 – AHV1600 TRANSCEIVER SYSTEM.....	4
Figure 101 – AHV1600 RADAR ALTIMETER SYSTEM BLOCK DIAGRAM	101
Figure 102 – AHV1600 TRANSCEIVER - GENERAL VIEW	102
Figure 103 – OVERALL DIMENSIONS	103
Figure 104 – MANUFACTURING SERIAL NUMBER LABEL	104
Figure 105 – THALES IDENTIFICATION LABEL.....	104
Figure 106 – AMENDMENT LABEL	105
Figure 107 – SPECIFIC LABEL.....	105
Figure 108 – ORGANIZATION OF HEIGHT DATA WORD LABEL “164”	108
Figure 109 – ORGANIZATION OF STATUS DATA WORD LABEL “271”	110
Figure 110 – ORGANIZATION OF STATUS DATA WORD LABEL “272”	112
Figure 111 – ORGANIZATION OF FIRST EQUIPMENT IDENTIFIER DATA WORD LABEL “371”	112
Figure 112 – ORGANIZATION OF INTERMEDIATE EQUIPMENT IDENTIFIER DATA WORD LABEL “371”	113
Figure 113 – ORGANIZATION OF LAST EQUIPMENT IDENTIFIER DATA WORD LABEL “371”	113
Figure 114 – ORGANIZATION OF STATUS DATA WORD LABEL “377”	114
Figure 115 – ORGANIZATION OF HEIGHT DATA WORD LABEL “165”	116
Figure 116 – ANT-140A INNER SIDE	121
Figure 117 – ANT-140A OUTER SIDE.....	121
Figure 201 – ANT-140A – ANTENNAE SEPARATION AND ORIENTATION	204
Figure 202 – SURFACES BONDING CONTACT OUTLINES	206
Figure 203 – INTERCONNECTIONS.....	211

THALES

THALES Communications

**OIM
AHV1600-SYSTEM**

INTRODUCTION

1. GENERAL INFORMATION

The manual contains the information for the installation and the operation of the AHV1600 Radar Altimeter P/N: AHV1600-01-01 00 A for Aircraft.

2. BLOCK PAGE NUMBERS FOR SECTIONS

Each section has a separate block page number:

- 1- 99 : General
- 101 - 199 : Presentation
- 201 - 299 : Installation
- 301 - 399 : Operation

All values have been given in the units (or multiples or sub-multiples of these units) of the International System (S.I.). It is possible that the values are given in more usual units. The English equivalents are given into brackets.

3. UPDATING

In case of update of the manual, detailed instructions for the insertion and deletion of applicable pages will be given.

Revised texts, new texts or deleted texts will be located with a vertical black line in the margin.

4. ADVISORIES

A. SAFETY INSTRUCTIONS / ELECTROSTATIC DISCHARGE PRECAUTIONS



This graphic symbol showing a hand on a dark background (to IEC 747-1 standard) means that the equipment on which it appears (assembly or subassembly) contains components sensitive to electrostatic discharges.

The following rules shall be complied with when carrying out any type of servicing on equipment bearing this symbol:

- The equipment shall be placed on a conducting or antistatic-working surface grounded through a resistance of between 250 kohm and 1 Mega-ohm.
- The operator shall wear a cotton smock and shall be linked with the working surface by a conducting wristband through a resistance of 1 Mega-ohm.
- Soldering iron shall be grounded.
- The transport and storage of parts removed from the equipment (printed board assemblies, modules, hybrid circuits, etc.) shall be done with conductive or antistatic packaging.

B. SHORT - CIRCUIT PRECAUTIONS

The inputs/outputs (I/O) are protected from short circuits but, by precautions no servicing shall be performed on any active or passive components while the equipment is energized.

5. UNCOMMON ABBREVIATIONS AND ACRONYMS

The following abbreviations, acronyms, and symbols are used in this manual:

Abbreviation/Acronym	Identification
A/D	Analogical/Digital
AGL	Above Ground Level
AID	Aircraft Installation Delay
ANT	ANTenna
AU	Altimeter Unit
BIT	Built In Test
CBIT	Continuous Built In Test
CR	Carriage Return
CSCI	Computer Software Configuration Item
CTZ	Coastal Transition Zone
CW	Continuous Wave
D/A	Digital/Analogical
dB	deciBel
dBm	deciBel milliwatt
DC	Direct Current
DMB	Digital and Management Board
EMC	ElectroMagnetic Compatibility
Fb	Beat Frequency
FM	Frequency Modulation
FT	Functional Test
Fore	Forward
HI	Hlgh
HIRF	High Intensity Radiated Fields (Lightning)
IBIT	Initiated Built-In-Test
IEC	International Electronical Commission
I/O	Input /Output
LO	Low
LRU	Line Replaceable Unit
LSB	Lower Significant Bit
MAX	MAXimum
MIN	MINimum
MPC	Multi Purpose Computer
NCD	No height Computer Data
NO	Normal Operation
PBIT	Power On Built In Test
PC	Printed Card
P/N	Part Number
R/A or RA	Radar Altimeter
RET	RETurn
RF	Radio Frequency
RL	Return Loss
Rx	Reception

Abbreviation/Acronym	Identification
S.I.	International System
ST	Saw Tooth
SWR	Standing Wave Ratio
Tx	Transmission
USB	Upper Significant Bit
VCO	Voltage Controlled Oscillator

EQUIPMENT IDENTIFICATION SHEET						
F0057		AHV1600_RADAR ALTIMETER SYSTEM				
<div style="text-align: center;"> <p>The diagram shows three components: the AHV1600 Transceiver (a rectangular metal box with various connectors and a lens), the Antenna ANT-140A (a circular antenna mounted on a square base), and a Coaxial cable (a flexible cable with connectors at both ends).</p> </div>						
PHYSICAL CHARACTERISTICS						
MAIN COMPONENTS	Qty	DIMENSIONS (mm)			WEIGHT (kg)	P/N
		Length	Width	Height		
Transceiver: AHV1600	1	190 max	90 max	95 max	≤ 2 kg	AHV1600-01-01 00 A
Antenna: ANT140A	2	105.41 max	90.17 max	33 max	0.130 ± 20 g	9599-607-12352
Coaxial cables not provided						

AHV1600 TRANSCEIVER TECHNICAL CHARACTERISTICS

- 1- Nominal power supply: 28 Vdc
 - 2- Power consumption: 20 W max (18 W typical)
 - 3- Power input interruption : ≤ 2 ms
 - 4- Connection: MIL C 39012 (TNC / RF connectors), MIL C38999 (main connectors)
 - 5- Performance:
 - Transmission : FM/CW.
 - Frequency Range : 4.2 GHz to 4.4 GHz.
 - Frequency Deviation : 123 MHz typical.
 - Transmitted Power : + 18 dBm (63 mW) max typical.
 - Height range accuracy : The maximum error, at every simulated height and within the temperature range - 40°C / + 70°C is : $\pm(2 \text{ ft} + 2 \% \text{ H})$
 - 6- Environmental conditions:
- DO160E Cat. [(B4)X]BBB[RG]XWFDIFSZZAZ[ZC][HF]M[(A4G33)(A3J33)]XXAX

AHV1600 TRANSCEIVER FUNCTIONAL CHARACTERISTICS

- FUNCTIONS OF THE EQUIPMENT:
 - Provide height Above Ground Level (AGL).
- EQUIPMENT INTERFACE:
 - Transmission antenna.
 - Reception antenna.
 - 28 Vdc supply
 - Main connector

GENERAL

1. AHV1600 RADAR ALTIMETER MAIN FUNCTION

The main function of the AHV1600 Radar Altimeter is to provide the height information, via an ARINC 429 digital bus, to the aircraft navigation system, in a range from 0 ft up to 5000 ft.

It uses the fact that the electromagnetic waves propagate through the air at a constant speed c , which is the speed of the light.

The height information is defined as the shortest distance to the "terrain" (ground or sea).

2. AHV1600 BASIC PRINCIPLE

The AHV1600 Transceiver measures altitude above ground as a function of elapsed time from the transmission of the electromagnetic wave to its return after reflection from the ground. The transmission time is directly proportional to the height above ground level.

It measures the shortest delay τ_0 between the transmitted wave and the received wave, linked to the minimum distance to the terrain H_0 by the formula:

$$\tau_0 = \frac{2.H_0}{c}$$

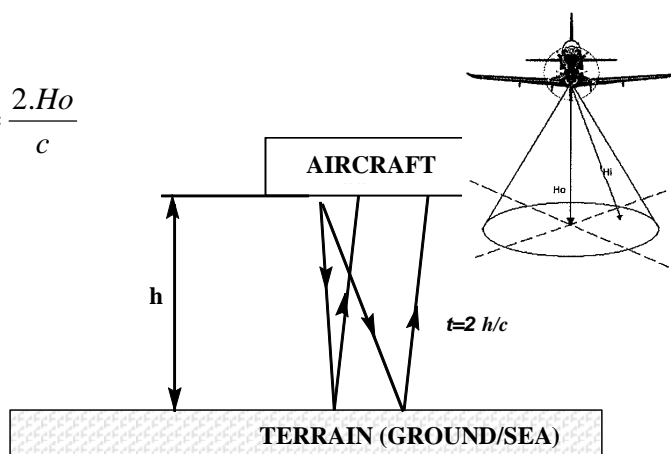

The AHV1600 Transceiver principle of operation is the FM/CW (Frequency Modulation / Continuous Wave) with variable slope modulation. The basic principle of this technique is to generate a saw tooth waveform with a slope of modulation varying as a function of altitude as shown on the figure below. The transmitted wave is linearly modulated in frequency by the saw tooth.

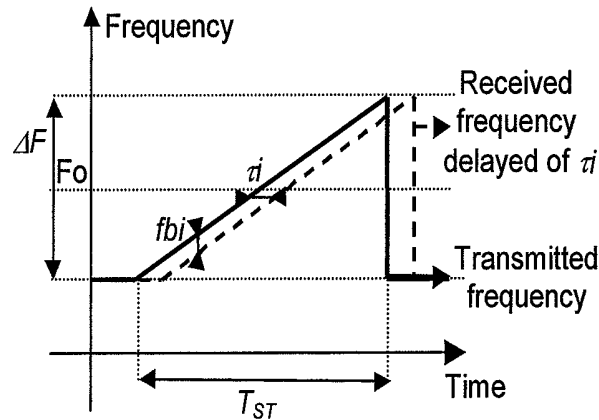

The AHV1600 Transceiver performs FM/CW modulation transmissions that are beat against the received reflection. The variable slope modulation allows the beat frequency to be maintained in a given bandwidth (window of 60 kHz to 110 kHz around centre frequency of 80 kHz). The window is then analysed through the equivalent of a 1 kHz bandwidth filter sweeping from 15 kHz to 110 kHz. The evaluation of the aircraft altitude is based on the measurement of the saw tooth duration and the position of the echo frequency in the window. The detection of the beat frequency spectrum is performed by a digital signal processing function.

The transmitted wave is linearly modulated in frequency by a saw tooth.

A beat signal is then obtained by mixing the transmitted waves $F(t)$ and received waves $F(t-\pi)$. At every instant, the frequency f_{bi} of this signal is equal to: $f_{bi} = F(t) - F(t-\pi)$

As the modulation is linear f_{bi} is linked to π and then to H_i by the formulae:

$$\frac{f_{bi}}{\Delta F} = \frac{\pi}{T_{ST}} = \frac{2 \cdot H_i}{c \cdot T_{ST}}$$

The f_{bi} frequencies form the beat signal spectrum.

This spectrum is constituted of all the frequencies from the ground and the thermal noise as well.

To enable a measurement of f_{bo} with a probability of noise detection compatible with the integrity requirements of the Radio Altimeter, a detection level is defined.

Only frequencies, which appear in the beat signal with energy above this level are taken into account.

As the frequencies f_{bi} and the heights H_i are proportional, the minimum distance to the ground H_0 is linked to the minimum frequency f_{bo} of the spectrum.

The Radio Altimeter then measures this frequency f_{bo} , the leading edge of the spectrum.

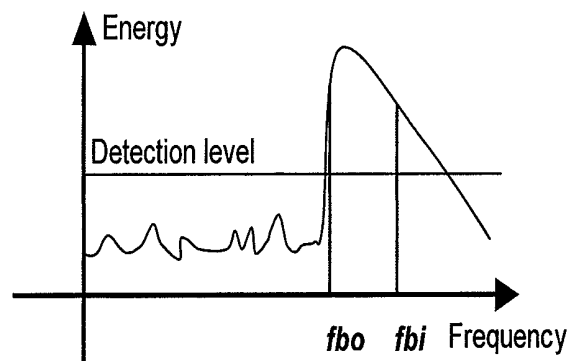

In the case of the Radio Altimeter, the frequency excursion ΔF is fixed and T_{ST} is made proportional to H_0 by a feedback loop that keeps f_{bo} in a constant frequency range. The accurate measurement of the minimum f_{b}

in the beat signal spectrum provides an accurate height measurement, and a T_{ST} for the feedback loop to keep fbo in its defined frequency range from one measurement to the other. Hence the relationship :

$$Ho = K \cdot fbo \quad \text{where} \quad K = \frac{c \cdot T_{ST}}{2 \cdot \Delta F}$$

3. BUILT IN TEST FUNCTION

The AHV1600 Transceiver implements an operational built-in test (BIT) in the following steps:

A. POWER-UP BUILT IN TEST (PBIT)

The AHV1600 Transceiver is capable of carrying out a performance test upon completion of the initialization sequence after power up to confirm the serviceability of the assembly. This test is performed in 3 s.

B. INITIATED BUILT IN TEST (IBIT)

The AHV1600 Transceiver is capable of carrying out a performance test to confirm the serviceability of the Transceiver upon receipt of the discrete input signal "FCT_TST". This test is performed in 3s.

C. CONTINUOUS BUILT IN TEST (CBIT)

The AHV1600 Transceiver is carrying out a continuous test of performance of the system as a background task. Continuous BIT provides coverage to the minimum extent possible without interfering with the normal Transceiver operation.

The BIT is controlled by the software embedded by the equipment.

4. AIRCRAFT INTERFACE

The AHV1600 transceiver interfaces with the following equipment :

- Airborne navigation computer,
- Airborne power supply,
- Two antennae.

The figure 1 shows a block diagram of the AHV1600 radar altimeter system:

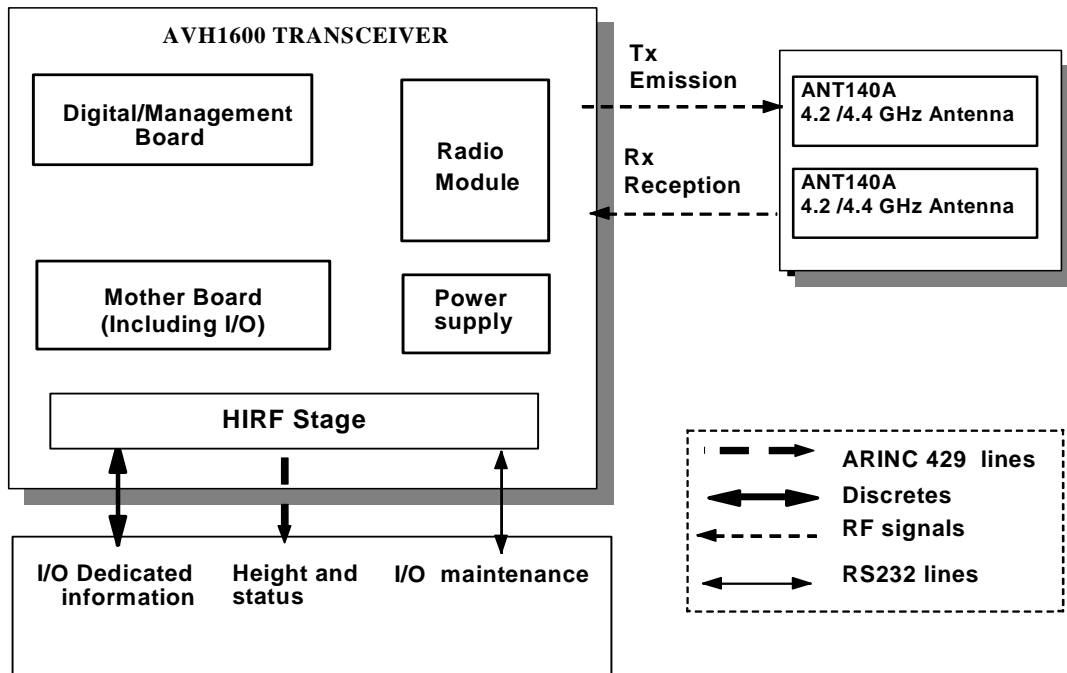

Figure 1 – AHV1600 RADAR ALTIMETER SYSTEM

PRESENTATION

1. AHV1600 RADAR ALTIMETER SYSTEM GENERAL DESCRIPTION

The Radar Altimeter System, named AHV1600, consists of three LRU (Line Replaceable Unit) and is composed of:

- one AHV1600 transceiver,
- one antenna ANT-140A to transmit radio frequency (RF) signal,
- one antenna ANT-140A to receive radio frequency (RF) signal.

Two coaxial cables (not provided) are necessary:

- one transmission cable, to connect the transmission antenna to the transceiver,
- one reception cable, to connect the reception antenna to the transceiver.

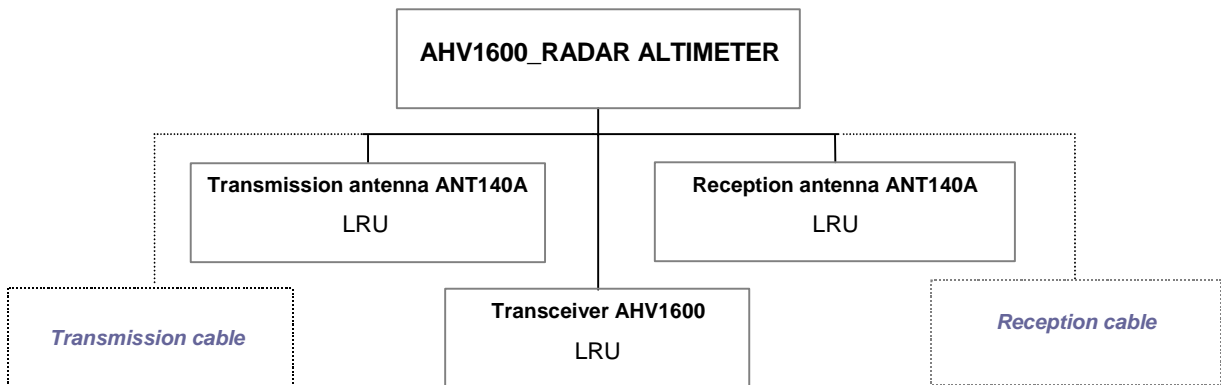

Figure 101 – AHV1600 RADAR ALTIMETER SYSTEM BLOCK DIAGRAM

The AHV1600 is an autonomous system mounted on an aircraft and connected to:

- 28 Vdc power supply line:
 - “P28V” and “RET28V” signals.
- Transmit and receive antennae for Radio Frequency (RF) signals through coaxial cables (“TX and RX” signals).
- Navigation and guidance systems through:
 - Dual differential ARINC429 digital output serial line (“TX429_HI_1, TX429_LO_1 and TX429_HI_2, TX429_LO_2” signals).

- Two discrete inputs (“FCT_TST and TST_INH” signals).
- Configurable inputs (“AID<2..0>, AID_P and SDI_SEL” signals).

2. AHV1600 TRANSCEIVER

The AHV1600 Transceiver is a compact and very light system. It is intended to fit the aircraft.

It is fixed on the aircraft structure by means of four M6 screws.

The unit is made up of a chassis with a front panel. The front panel is equipped with:

- one main connector,
- two coaxial connectors:
 - one reception connector« Rx »,
 - one transmission connector« Tx ».

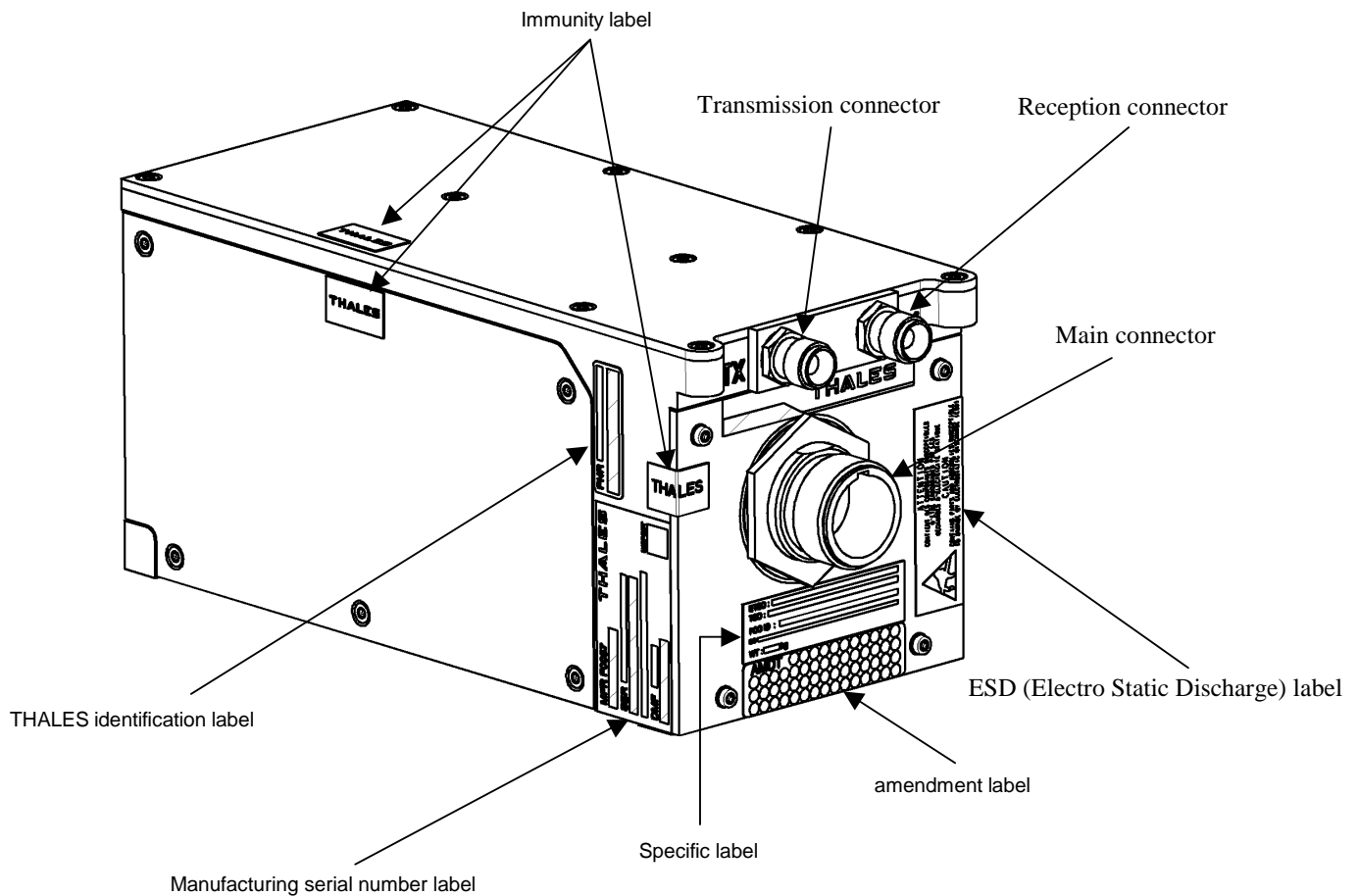

Figure 102 – AHV1600 TRANSCEIVER - GENERAL VIEW

A. EXTERNAL CHARACTERISTICS

(1) PHYSICAL CHARACTERISTICS

Dimensions (see figure 103): max. 190 x 90 x 95 mm.

The weight of the unit is < 2 kg.

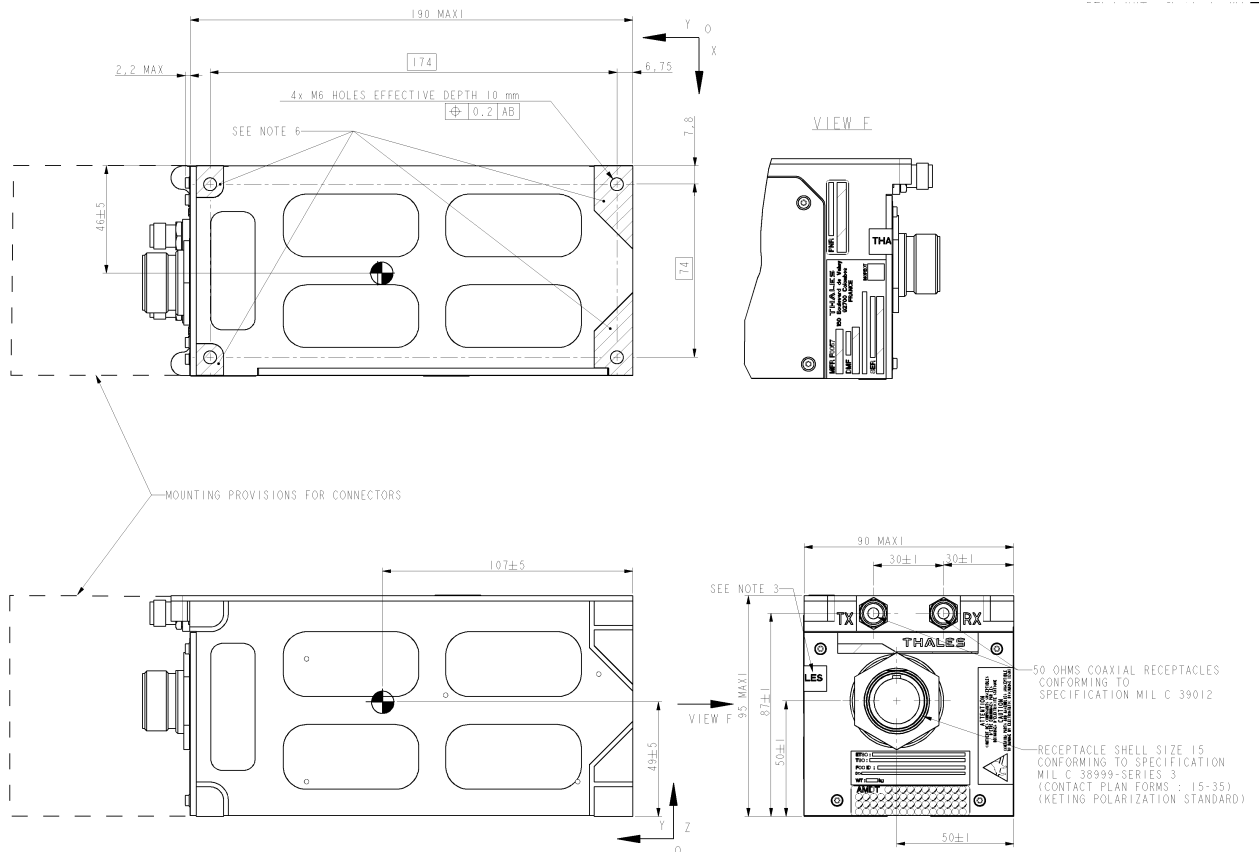

Figure 103 – OVERALL DIMENSIONS

Note: all dimensions are in mm

(2) FRONT PANEL

The front panel bears the antennae connectors, the main connectors, the specific label, the amendment label, the ESD label and the immunity label.

All connectors are equipped with special caps provided electrical shielding as well as mechanical protection.

(3) IDENTIFICATION

(a) Manufacturing Serial Number Label

The manufacturing serial number label is stuck on the left side (refer to Figure 102). It is divided into four fields, which provide the following indications:

Field Number	Field
1	Serial number
2	LRU Description
3	Date of manufacturing
4	Inspection stamp

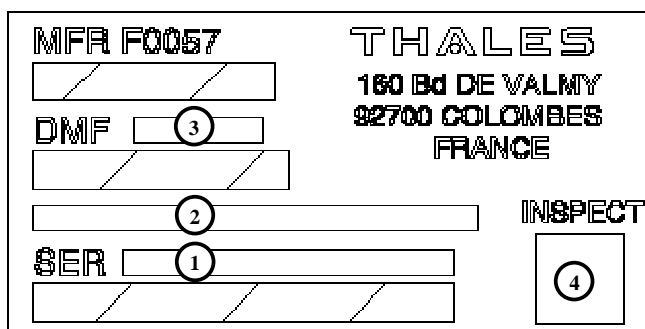

Figure 104 – MANUFACTURING SERIAL NUMBER LABEL

(b) THALES Identification Label

The THALES identification label is stuck on the left side (refer to Figure 102). One field provides the following indication:

Field Number	Field
1	THALES commercial part number

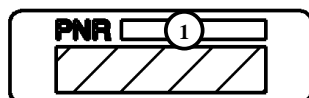

Figure 105 – THALES IDENTIFICATION LABEL

(c) Amendment label

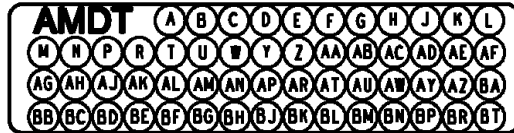

Figure 106 – AMENDMENT LABEL

(d) Specific label

The specific label is stuck on the front panel (refer to Figure 102). It is divided into five fields, which provide the following indications:

Field Number	Field
1	ETSO certification number
2	TSO certification number
3	FCC ID designation
4	DO designation
5	Weight

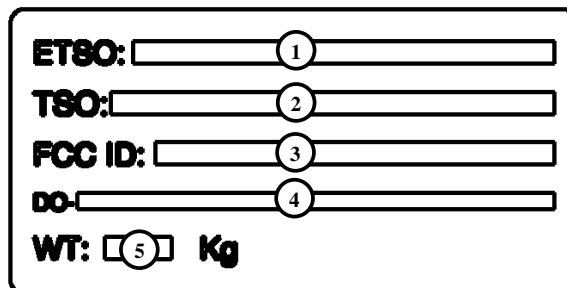

Figure 107 – SPECIFIC LABEL

B. INTERNAL SUB-ASSEMBLIES

The AHV1600 Transceiver contains the following sub-assemblies:

- The Digital chassis:
 - Performs the High Intensity Radiated Field (HIRF) protection, internal module interconnection, digital and management processor capacity and power supply distribution,
 - Provides the helicopter with the mechanical and electrical interfaces,
 - Provides the hardware support of the downloaded software's.
- The radio module:
 - Performs the Radio Frequency (RF) signal emission, the Radio Frequency (RF) signal reception and the Beat Frequency (BF) signal extraction.

C. FUNCTIONAL CHARACTERISTICS

(1) OPERATION DATA

- Output signals characteristics : ARINC 429 standard
 - Radar Altimeter height : ARINC word label 164 and 165 (BNR and BCD)
 - Radar Altimeter Status : ARINC word label 272
 - Timing between both word labels is described hereafter:
 - First ARINC 429 output (serial) : IRS1 TX HI (+) / IRS1 TX LO (-)
 - Second ARINC 429 output (serial) : IRS2 TX HI (+) / IRS2 TX LO (-)
 - ARINC 429 specification:
 - Exchange: unidirectional asynchronous
 - Word format: 32 bits data transfer with LSB transmitted in first
 - Label format: 8 bits in octal coding from LSB position of the word
 - Parity format: 1 odd parity bit at MSB position of the word
 - Inter word gap: 4 bits minimum

Note: on each word, the odd parity bit is always computed from the first 31 data bits of the word.

- Bit duration : $80 \mu\text{s} \pm 2 \mu\text{s}$
- Bit form factor : $40 \mu\text{s} \pm 2 \mu\text{s}$

Note : the bit duration corresponds to a low speed operation at 12.5 kbps.

- ARINC signals Transmission speed : 12.5 kbps
- Input signals : AID0, AID1, AID2, AID_P
 - Low level voltage $\leq +3.5$ VDC with sink current < 2 mA (logic state 1).
 - High level voltage $\geq +15.3$ VDC with sink current < 1 mA (logic state 0).
 - Maximum level voltage $\leq +32.2$ V_{DC}.

when measured to the “M_GND” reference signal.

- Frame structure on IRSx TX HI/LO differential output serial line:
 - six words transmitted in accordance with the following chronological order:
 - 1- Height data word label 164
 - 2- Status data word label 271
 - 3- Status data word label 272
 - 4- Data word label 371 (first equipment identifier data word)
 - 5- Height data word label 377
 - 6- Height data word label 165

- Frame rate on IRSx TX HI/LO differential output serial line: 40 ms ± 1 ms

(2) DATA WORD ORGANIZATION

(a) height data word label 164 description :

Label data field:

<i>Bits<8..1></i>	<i>Label value</i>
001 011 10	164 _{OCT}

Source Destination Identifier (SDI) data field :

<i>Bits<10..9></i>	<i>Discrete input “SDI_SEL”</i>
00	Undefined
01	Discrete grounded
10	Discrete open
11	Not used

Functional Test Inhibit (FTI) data:

<i>Bits<11></i>	<i>Discrete input “TST_INH”</i>
0	Discrete open
1	Discrete grounded

Height data field:

Bits<29..13>Height value
Height range from 0 ft up to + 5500 ft LSB value 0.125 ft Height value coded in 2 complement on 17 bits (Sign bit<29> - LSB bit<13>)

Status Matrix data field (BNR numeric data word):

Bits<31..30>	Validity
00	Failure warning (FW)
01	No Computed Data (NCD)
10	Functional Test (FT)
11	Normal Operation (NO)

32	31	30	29	28	27	26	25	24	23	22	21	20	19	18	17	16	15	14	13	12	11	10	9	8	7	6	5	4	3	2	1	
Parity	SM	Sign	Height data value in BNR format coded in two's complement																	LSB	Spare	FTI	SDI	LSB	Label « 164 »							MSB
																									0				0	0	1	

Figure 108 – ORGANIZATION OF HEIGHT DATA WORD LABEL “164”

(b) Status data word label 271 description

Label data field:

Bits<8..1>	Label value
100 111 01	271 _{OCT}

Source Destination Identifier (SDI) data field :

<i>Bits<10..9></i>	<i>Discrete input "SDI_SEL"</i>
00	Undefined
01	Discrete grounded
10	Discrete open
11	Not used

Aircraft Installation delay (AID) data field :

<i>Bits<14..11></i>		<i>AID Value (fte)</i>
<i>AID_P</i>	<i>AID<2..0></i>	
0	111	Reserved
1	111	Configurable input value not authorized
0	110	Configurable input value not authorized
1	110	Reserved
0	101	Configurable input value not authorized
1	101	Reserved
0	100	Reserved
1	100	Configurable input value not authorized
0	011	Configurable input value not authorized
1	011	Reserved
0	010	Reserved
1	010	Configurable input value not authorized
0	001	46.625fte
1	001	Configurable input value not authorized
0	000	Reserved
1	000	Undefined

Functional Test data:

<i>Bits<17></i>	<i>Discrete input "FCT_TST"</i>
0	Discrete grounded
1	Discrete open

Test inhibit data:

Bits<18>	Discrete input "TST_INH"
0	Discrete grounded
1	Discrete open

Status Matrix data field (discrete data word):

Bits<31..30>	Validity
00	Normal Operation (NO)
01	Not used
10	Not used
11	Failure warning (FW)

32	31	30	29	28	27	26	25	24	23	22	21	20	19	18	17	16	15	14	13	12	11	10	9	8	7	6	5	4	3	2	1
Parity	SM	Spare	Spare	Spare	Spare	Spare	Reserved	Reserved	Reserved	Reserved	Reserved	Reserved	TST_INH	FCT_TST	Reserved	Reserved	AID_P	AID2	AID1	AID0	SDI	Label « 271 »						MSB			
		0	0	0	0	0																1	0	0	1	1	1	0	1		

Figure 109 – ORGANIZATION OF STATUS DATA WORD LABEL "271"

(c) Status data word label 272 description

Label data field:

Bits<8..1>	Label value
010 111 01	272 _{OCT}

Source Destination Identifier (SDI) data field :

Bits<10..9>	Discrete input "SDI_SEL"
00	Undefined
01	Discrete grounded
10	Discrete open
11	Not used

AHV1600 Transceiver function data field :

Bits<18..17>	AU Transceiver function"
00	Search
01	Track
10	No function
11	Reserved

PBIT / IBIT data :

Bits<19>	PBIT / IBIT
0	BIT in progress
1	BIT not required

AHV1600 Transceiver mode data field:

Bits<21..20>	AU Transceiver mode
00	Reserved
01	Operational
10	Reserved
11	Reserved

Failure data field:

Logic state	Bit<29..24>					
	Tx antenna	Rx antenna	PSU	I/O	CPU	Radio
0	Failure					
1	No failure					

Radio failure: Problem detected on radio board

CPU failure: Problem detected on CPU board

I/O failure: Problem detected on I/O board

PSU failure: Problem detected on PSU board

Rx antenna failure: Impedance on RX antenna fail (50 ohms not detected)

Rx antenna failure: Impedance on TX antenna fail (50 ohms not detected)

Status Matrix data field (discrete data word):

Bits<31..30>	Validity
00	Normal Operation (NO)
01	Not used
10	Not used
11	Failure warning (FW)

32	31	30	29	28	27	26	25	24	23	22	21	20	19	18	17	16	15	14	13	12	11	10	9	8	7	6	5	4	3	2	1							
Parity	SM		Tx_ANT failure	Rx_ANT failure	PSU failure	I/O failure	CPU failure	Radio failure	Spare	Spare	AU Transceiver mode		PBIT / IBIT	AU Transceiver function		Reserved	Reserved	Reserved	Reserved	Reserved	Spare	SDI	Label « 272 »															MSB
									0	0												0			0	1	0	1	1	1	0	1						

Figure 110 – ORGANIZATION OF STATUS DATA WORD LABEL “272”

(d) Status data word label 371 description

Several words label “371” are required to transmit the equipment identifier data. These words label “371” are encapsulated by the “STX” and “EOT” words label “371” to form the global transmission of the equipment identifier data.

32	31	30	29	28	27	26	25	24	23	22	21	20	19	18	17	16	15	14	13	12	11	10	9	8	7	6	5	4	3	2	1
Parity	STX						Spare						MSB	Block Word Count				LSB	Label « 371 »										MSB		
0	0	0	0	0	0	1	0	0	0	0	0	0	0	0	0	0	X	X	X	X	X	X	X	1	0	0	1	1	1	1	1

Figure 111 – ORGANIZATION OF FIRST EQUIPMENT IDENTIFIER DATA WORD LABEL “371”

“Name” data field defined as per three characters:

Name>	Discrete input “SDI_SEL”
RA	Undefined
RA1	Discrete grounded
RA2	Discrete open

“Part Number” data field defined as per ten characters. e.g. “61778974AC”

“Serial Number” data field defined as all characters from Part Number plus five number characters. e.g. “61778974AC11111”

32	31	30	29	28	27	26	25	24	23	22	21	20	19	18	17	16	15	14	13	12	11	10	9	8	7	6	5	4	3	2	1
Parity	MSB Character = 3 LSB							Spare	MSB Character = 2 LSB							Spare	MSB Character = 1 LSB							LSB Label « 371 » MSB							
																								1	0	0	1	1	1	1	1

Figure 112 – ORGANIZATION OF INTERMEDIATE EQUIPMENT IDENTIFIER DATA WORD LABEL “371”

The last equipment identifier data word label “371” shall indicate the end of transmission of equipment identifier data by transmitting the “EOT” character.

32	31	30	29	28	27	26	25	24	23	22	21	20	19	18	17	16	15	14	13	12	11	10	9	8	7	6	5	4	3	2	1
Parity	EOT							Spare														LSB Label « 371 » MSB									
0	0	0	0	0	1	0	0	0	0	0	0	0	0	0	0	0	0	0	0	0	0	0	0	1	0	0	1	1	1	1	1

Figure 113 – ORGANIZATION OF LAST EQUIPMENT IDENTIFIER DATA WORD LABEL “371”

(e) Height data word label 377 description

Label data field:

<i>Bits<8..1></i>	<i>Label value</i>
111 111 11	377 _{OCT}

Source Destination Identifier (SDI) data field :

<i>Bits<10..9></i>	<i>Discrete input "SDI_SEL"</i>
00	Undefined
01	Discrete grounded
10	Discrete open
11	Not used

Equipment identification data field:

<i>Bits<22..11></i>	<i>Equipement identification</i>
111 111 11	007 _{HEX}

Status Matrix data field (discrete data word):

<i>Bits<31..30></i>	<i>Validity</i>
00	Normal Operation (NO)
01	Not used
10	Not used
11	Failure warning (FW)

32	31	30	29	28	27	26	25	24	23	22	21	20	19	18	17	16	15	14	13	12	11	10	9	8	7	6	5	4	3	2	1		
Parity	SM	No data								MSB	Equipment Identification Code											LSB	SDI	LSB	Label « 377 »								MSB
		0	0	0	0	0	0	0	0		0	0	0	0	0	0	0	0	0	0	0				1	1	1	1	1	1	1	1	

Figure 114 – ORGANIZATION OF STATUS DATA WORD LABEL "377"

(f) Height data word label 165 description

Label data field:

Bits<8..1>	Label value
101 011 10	165 _{OCT}

Source Destination Identifier (SDI) data field :

Bits<10..9>	Discrete input "SDI_SEL"
00	Undefined
01	Discrete grounded
10	Discrete open
11	Not used

Height data field:

Bits<29..11>Height value
Height range from 0 ft up to + 5500 ft LSB value 0.1 ft Height value in binary coded decimal on 19 bits (MSB bit<29> - LSB bit<11>)

Status Matrix data field (BCD numeric data word) :

Bits<31..30>	Validity"
00	Normal Operation
01	No computer Data (NCD)
10	Functional Test (FT)
11	Not used

32	31	30	29	28	27	26	25	24	23	22	21	20	19	18	17	16	15	14	13	12	11	10	9	8	7	6	5	4	3	2	1				
Parity	SM	MSB	Height data value in BCD format																			LSB	SDI	LSB	Label « 165 »										MSB
			0	0	0	0	0	0	0	0	0	0	0	0	0	0	0	0	0	0	1				1	1	1	1	0	1	0	1	0	1	

Figure 115 – ORGANIZATION OF HEIGHT DATA WORD LABEL “165”

(3) DISCRETE INPUT SIGNAL

(a) Discrete input signal “FCT_TST”

The AHV1600 transceiver receives the discrete input signal “FCT_TST” from the navigation and guidance systems to activate its “Built In Test (BIT)” function.

The “FCT_TST” discrete input signal shall initiate the following function of the AHV1600 transceiver:

- Built In Test function initiated when it is set to low level voltage (discrete grounded).
- Built In Test function not initiated when it is set to high level voltage (discrete open).

To initiate the internal Built In Test function of the AHV1600 transceiver, the minimum time duration of “FCT_TST” discrete input signal shall be 200ms when measured at 50% level of the electrical changing voltage.

In the AHV1600 transceiver, the “FCT_TST” discrete input signal shall be in accordance with the following electrical characteristics:

- Low level voltage $\leq + 3.5$ VDC with sink current < 2 mA (discrete grounded).
- High level voltage $\geq +15.3$ VDC with sink current < 1 mA.
- Maximum level voltage $\leq +32.2$ VDC.

when measured to the “M_GND” reference signal.

In the AHV1600 transceiver, the discrete input signal “FCT_TST” shall be protected against the indirect effect of lightning.

(b) Discrete input signal “TST_INH”

The AHV1600 transceiver receives the discrete input signal “TST_INH” from the navigation and guidance systems to inhibit its “Built In Test (BIT)” function.

The “TST_INH” discrete input signal shall inhibit the following function of the AHV1600 transceiver:

- Initiated Built In Test (IBIT) function inhibited when it is set to low level voltage (discrete grounded).
- Initiated Built In Test (IBIT) function enabled when it is set to high level voltage (discrete open).

In the AHV1600 transceiver, the discrete input signal "TST_INH" shall be in accordance with the following electrical characteristics:

- Low level voltage $\leq + 3.5$ VDC with sink current < 2 mA (discrete grounded).
- High level voltage $\geq +15.3$ VDC with sink current < 1 mA.
- Maximum level voltage $\leq +32.2$ VDC.

when measured to the "M_GND" reference signal.

To inhibit the internal Built In Test function of the AHV1600 transceiver, the minimum time duration of "TST_INH" discrete input signal shall be 200ms when measured at 50% level of the electrical changing voltage.

In the AHV1600 transceiver, the discrete input signal "TST_INH" shall be protected against the indirect effect of lightning.

3. OPERATIONAL INTERFACES

A. POWER SUPPLY

The Transceiver shall be powered with a 28 Vdc ± 5 %.

The voltage transients shall be:

- range 21 V to 32 V for up to 2 ms,
- range 21 V to 38 V for up to 1 ms.

The Transceiver shall be not damaged in unusual conditions:

- 50 V during 50 ms.

B. DIGITAL ARINC429 INTERFACE

This digital interface outputs the altitude information exchanged between the Transceiver and the navigation computer. There is no ARINC 429 input.

All information is through the Main receptacle J1.

ARINC 429 outputs are differential output signals:

- first ARINC429 output (IRS1 TX HI / IRS1 TX LO),
- second ARINC 429 output (IRS2 TX HI / IRS2 TX LO).*

(1) ELECTRICAL CHARACTERISTICS

(a) When measured to the AID ground reference signal in open circuit

- differential low level voltage : - 10 Vdc ± 1 Vdc
- differential high level voltage : + 10 Vdc ± 1 Vdc

- differential null level voltage : 0 Vdc \pm 0.5 Vdc
- differential output impedance : 75 Ω \pm 5 Ω

(b) When measured to the AID ground reference signal in loaded circuit

- differential low level voltage : between $\geq - 11$ Vdc and $\leq - 7.25$ Vdc
- differential high level voltage : between $\geq + 7.25$ Vdc and $\leq + 11$ Vdc
- differential null level voltage : between $\geq - 0.5$ Vdc and $\leq + 0.5$ Vdc

(2) LIGHTNING PROTECTION

Both differential output signals are protected against the indirect effect of lightning.

(3) TIMING CHARACTERISTICS

- Differential rise time : 10 μ s \pm 5 μ s.
- Differential fall time : 10 μ s \pm 5 μ s.

When measured from 10% to 90% level of the differential changing voltage in open circuit.

C. AID SIGNALS INTERFACE**(1) CONFIGURABLE INPUT SIGNALS**

The transceiver receives the configurable input signals "AID_P" and "AID <2..0>" from the Navigation computer to code the Aircraft Installation Delay. To select the Aircraft Installation Delay, each dedicated "AID_P" and "AID <2..0>" configurable input signal must be connected as short as possible to the "AID GROUND" reference signal (or left open).

(2) ELECTRICAL CHARACTERISTICS

- Low level voltage : $< + 3.5$ Vdc with sink current < 2 mA (logic state 1),
- High-level voltage : $> + 15.3$ Vdc with sink current < 1 mA (logic state 0),
- Maximum level voltage $\leq + 32.2$ Vdc.

When measured to the "M_GND" reference signal.

(3) LIGHTNING PROTECTION

- Configurable input signals are protected against the indirect effect of lightning.

(4) FUNCTIONAL CHARACTERISTICS

- AID length definition: from TX transceiver output to TX antenna through coaxial cable and from TX antenna to ground through the air and from ground to RX antenna through the air and from RX antenna to RX input transceiver through coaxial cable
- AID is coded by the "AID_P" and "AID <2..0>" configurable input signals.

(5) PERFORMANCE

- Altitude: 5000 ft
- Height accuracy: (± 2 ft + 2% of the true height)

D. ENVIRONMENTAL CONDITIONS

DO160E Cat. [(B4)X]BBB[RG]XWFDZSZZA[ZC][HF]M[(A4G33)(A3J33)]XXAX

Environmental Condition DO160E	DO160E section	Description of conducted test
Temperature and altitude	4	Category B4
Temperature variation	5	Category B
Humidity	6	Category B
Operational shocks and crash safety	7	Category B
Vibration	8	Category R curve G
Explosive atmosphere	9	Not required Category X
Waterproofness	10	Category W
Fluids susceptibility	11	Category F
Sand and dust	12	Category D
Fungus resistance	13	Category F
Salt Fog	14	Category S
Magnetic effect	15	Category Z
Power input	16	Category Z TCF declares that the AHV1600 Transceiver is able to withstand momentary power interruption up to 2ms (Test condition 1 of table 16-3).
Voltage spike	17	Category A
Audio frequency conducted susceptibility – power inputs	18	Category Z
Induced signal susceptibility	19	Category ZC
Radio frequency susceptibility (radiated and conducted)	20	Category H for Conducted Susceptibility Category F for Radiated Susceptibility
Emission of radio frequency energy	21	Category M
Lightning induced transient susceptibility	22	Pin Injection Tests : Equipment tested to Category (A4) for power lines and (A3) for interconnecting lines. Cable Bundle Tests : Equipment tested to Category (G33) for power lines and (J33) for interconnecting lines.
Lightning direct effects	23	Not required Category X
Icing	24	Not required Category X
Electrostatic discharge	25	Category A
Fire, Flammability	26	Not required Category X

E. IN FLIGHT CONDITIONS

In-flight conditions are defined in the following table:

Height range domain	From 0 ft to 5000 ft	ED-30 height range category B
Horizontal velocity	From 0 ft/s to 500 ft/s up to H = 500 ft From 0 ft/s to 1000 ft/s up to H = 500 ft	ED-30 in-flight condition category L/P
Height variation velocity	From 0 ft/s to 20 ft/s up to H = 50 ft From 0 ft/s to 50 ft/s at 50 ft < H < 500 ft From 0 ft/s to 500 ft/s at 500 ft < H < 800 ft From 0 ft/s to 2000 ft/s above H = 800 ft	
Pitch angle	Range of 0 to $\pm 25^\circ$ (at - 3 dB)	
Roll angle	Range of 0 to $\pm 45^\circ$ (at - 3 dB)	ED-30 in-flight condition category L

Radar Altimeter in-flight conditions

4. ANTENNA ANT-140A

A. GENERALITIES ON ANTENNA ANT-140A

The ANT140A antenna is a flat antenna for AHV1600 Radar Altimeter.

The complete installation of the Radar Altimeter requires two identical antennae ANT-140A: one for transmission (Tx) and one for reception (Rx). These two antennae must be suitably located and connected by coaxial cables to the transceiver.

The antenna is certified by the DO160B certification.

B. PHYSICAL CHARACTERISTICS

- Dimensions: 105.41 x 90.17 x 33 mm,
- Weight: 130 \pm 20 g,

The antenna is fitted with a female TNC 50 ohms coaxial connector. The connector is protected with a special cap that must be removed before connecting the antenna.

Two labels equip the antenna: an identification label and an amendment label.

A red ink marking indicates antenna orientation into aircraft.

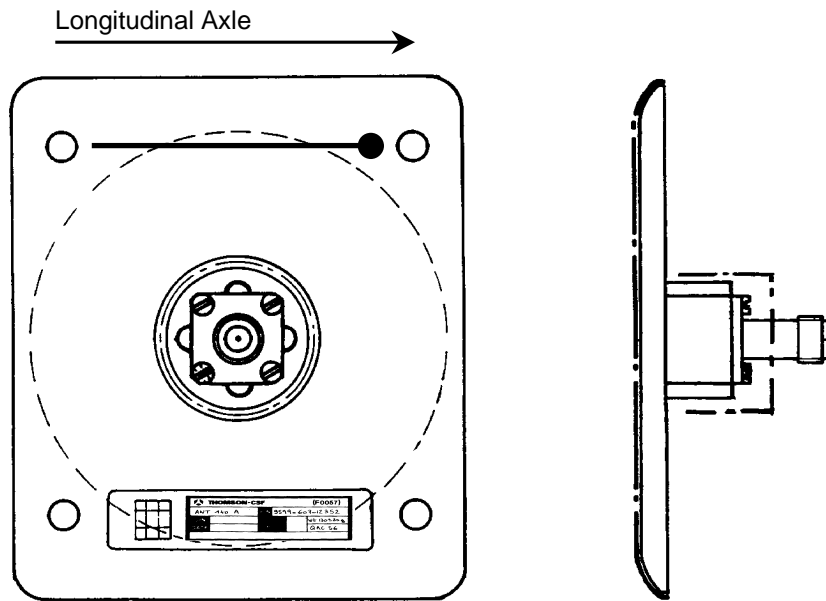

Figure 116 – ANT-140A INNER SIDE

The outside bears the inscription “DO NOT PAINT”, as well as an antenna-positioning symbol.

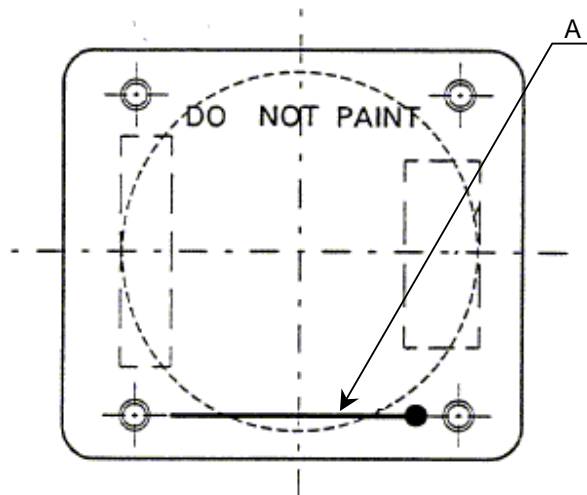
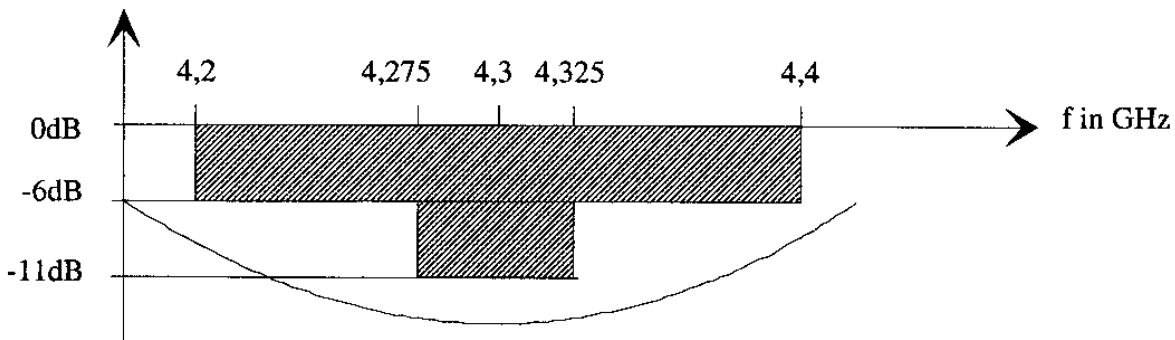

Figure 117 – ANT-140A OUTER SIDE

A: Antenna-positioning symbol

C. FUNCTIONAL CHARACTERISTICS

- Operating frequency band: 4.2 GHz – 4.4 GHz.
- Match:
 - The return loss on 50 ohms complies with the following diagram



- Isotropic gain:
 - ≥ 7 dBi from 4.2 GHz to 4.4 GHz
- Radiation pattern:

Half-power beamwidth (- 3 dB):

 - Roll (E-Plane) : $60^\circ \pm 7^\circ$
 - Pitch (H-Plane) : $50^\circ \pm 5^\circ$

NOTE:

The E-plane is perpendicular to the direction of the straight line painted on the external antenna front face.

The H-plane is parallel to the direction of the straight line.

- Decoupling:
 - The decoupling value for a distance of 0.4 m between antenna centres is ≥ 72 dB.
- Grounding:
 - The resistance between connector core and its shielding is < 0.05 ohm.

5. COAXIAL CABLES LENGHT

(1) RECOMMENDED CABLE TYPE (ACCORDING TO MIL.C 17F SPECIFICATION)

Double screened coaxial is essential to avoid RF leakage.

(2) AID DEFINITION

Installation Delay (AID) is the total electrical length from the transceiver transmitting output port to the aircraft skin, via the transmitting antenna the add to the distance from the antenna to the ground, add to the distance from ground to receive antenna and back to the transceiver receiving output via the receiving antenna.

$L_1 + L_2$ Electrical length (in feet) of the coaxial cables between the transceiver and transmitting and receiving antennas respectively.

$L_3 + L_4$ Distance (in feet) between transmitting and receiving antennas to the ground when the aircraft is on the ground

ANT_1 and ANT_2 are the electrical length (in feet) of antennas (1.5 ft per antenna)

The formula for cable mechanical length calculation is:

$$Le + Lr = \frac{[AID - 2 \sqrt{((\frac{D}{2})^2 + H^2)} - ANT_1 - ANT_2]}{\sqrt{\epsilon}}$$

Where,

- $Le + Lr$ Mechanical length (in feet) of cables
with $L_1 = Le \sqrt{\epsilon}$ and $L_2 = Lr \sqrt{\epsilon}$
- D Center-to-center distance (in feet) between antennas
- H Antennas height (in feet) over the ground
- ϵ Dielectric constant of cables
- $\sqrt{\epsilon}$ Velocity factor of cable

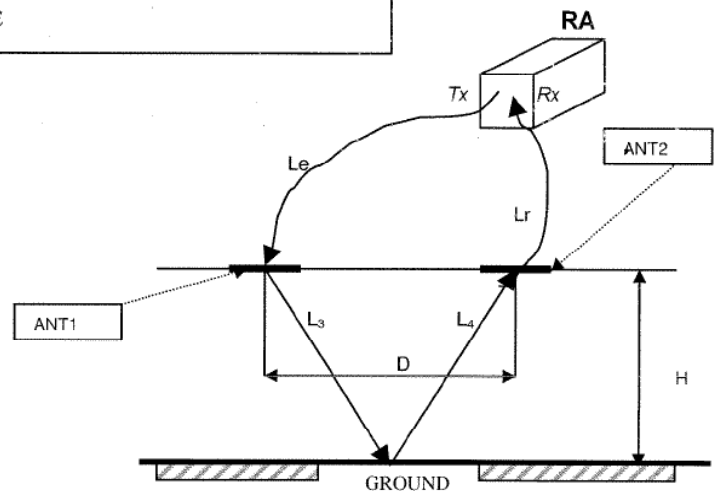

INSTALLATION

1. GENERAL CONDITIONS

A. POWER SUPPLY

A nominal voltage of 28 Vdc powers the equipment.

It can nevertheless operate within a DC power supply range of 22 V to 30.3 V.

The absorbed power at 28 V is less than 20 W. It is typically 18 W.

The primary power supply circuit is isolated from the secondary circuit.

B. LOCATION

When selecting a location for equipment and working out the details for installation in the platform, the objectives should be easy implementation and replacement of the equipment and radar altimeter as close as possible from the antennae.

C. WATER, SAND, AND DUST TIGHTNESS

Although the equipment is designed to withstand salt spray and a high degree of humidity, it is not waterproof and precautions should be taken to protect it against trickling or sprayed water (according to its specifications).

D. MOUNTING

The AHV1600 Transceiver is fixed on the platform by means of four M6 screws, without any preferred orientation.

E. INSTALLATION CONDITIONS

The AHV1600 Radar altimeter normal installation conditions are described hereafter:

- Radio Frequency (RF) isolation between the transmission and reception antennae > 75 dB.
- Adaptation of each antenna 50 ohms, over the frequency range (4.2 GHz to 4.4 GHz).
- Gain of each antenna at least 7 dBi and 11 dBi maximum, over the frequency range 4.2 GHz to 4.4 GHz.
- Aperture angles of the antennae are at - 3 dB (with ANT-140A):
 - in pitch $\pm 25^\circ \pm 2.5^\circ$.
 - in roll $\pm 30^\circ \pm 3.5^\circ$.

- VSWR 3 to 1 of each antenna (return loss of - 6 dB or less) over the frequency range 4.2 GHz to 4.4 GHz.
- All sides lobes of each antenna must be down 40 dB or better.
- Coax cable 50 ohms double shielded type RG400 or equivalent.
- Losses in both the transmission and reception coaxial cables are of 4 dB minimum and 7 dB maximum.
- Each antenna shall be grounded on the aircraft frame, on a common metallic grounded structure for both antennae. The dimension of this structure being at least 15 cm around each antenna.
- No conductive features between antennae or within at least 30 cm around each antenna should be accepted. Furthermore no conductive features should be seen in a cone of $\pm 70^\circ$ centered on each antenna.
- Avoid antennae to be fitted close to landing gear doors, landing gear or skids.
- Antennae should be preferably installed on a flat and horizontal surface. In any cases two antennae of a given system shall have no more than a 5° angle between their planes. Furthermore, users have to take into account the fact that tilting any antenna with respect to the aircraft horizontal plane will affect the system performances in terms of capability to withstand aircraft's attitudes.
- The residual resistance between the structure of the aircraft and the structure of each antenna (body of the coaxial connector) shall not exceed 2.5 milliohm.
- The residual resistance between the structure of the aircraft and the structure of the transceiver (body of the coaxial connector, main connector or specific reference mechanical ground pins in the main connector) shall not exceed 2.5 milliohm.

2. STEP BY STEP TRANSCEIVER INSTALLATION

The AHV1600 Transceiver is fitted with a main MIL-C-38999 series III, 37 contacts connector and two female MIL-C-39012/TNC coaxial connectors.

Two antennae ANT140A – transmission and reception – are required for the AHV1600 Transceiver. They are connected by means of two coaxial cables to the AHV1600 Transceiver.

Recommended installation flowcharts:

- control the Transceiver visual aspect,
- secure the Transceiver,
- connect the Main connector,
- connect the coaxial cables.

Warning: before connecting Main connector, be sure 28 Vdc Transceiver supply is inhibited.

A. CHOICE OF ANTENNAE LOCATION

- Choose the location of the antennae carefully. On it will depend the operation of the Transceiver in all flight configurations.
- Antennae are generally mounted:
 - Under the fuselage.
 - Such that the H fields are collinear - this configuration corresponds to maximum decoupling between antennae. The antennae centre line should be preferably parallel to the aircraft Fore and AFT axis.
 - Along a plane parallel to the ground for a normal aircraft flight attitude; if it is not possible to mount the antennae horizontally, a maximum angle of 5 degrees may be tolerated.

CAUTION: Pitch and roll performances may be degraded for angles exceeding this figure.

- At a location that is preferably perfectly clear of any obstacles in order to avoid hindrance of the Transceiver by fixed obstacles (landing gear, fuel tanks, other antennae).
- The distance between antennae should be chosen on the basis of two criteria:
 - Sufficiently large distance to ensure proper decoupling.
 - Sufficiently small distance to ensure proper overlapping of radiation lobes for the minimum height of the antennae above the ground (touchdown or parking position).
- The distance between antennae should be the following (see Figure 201).

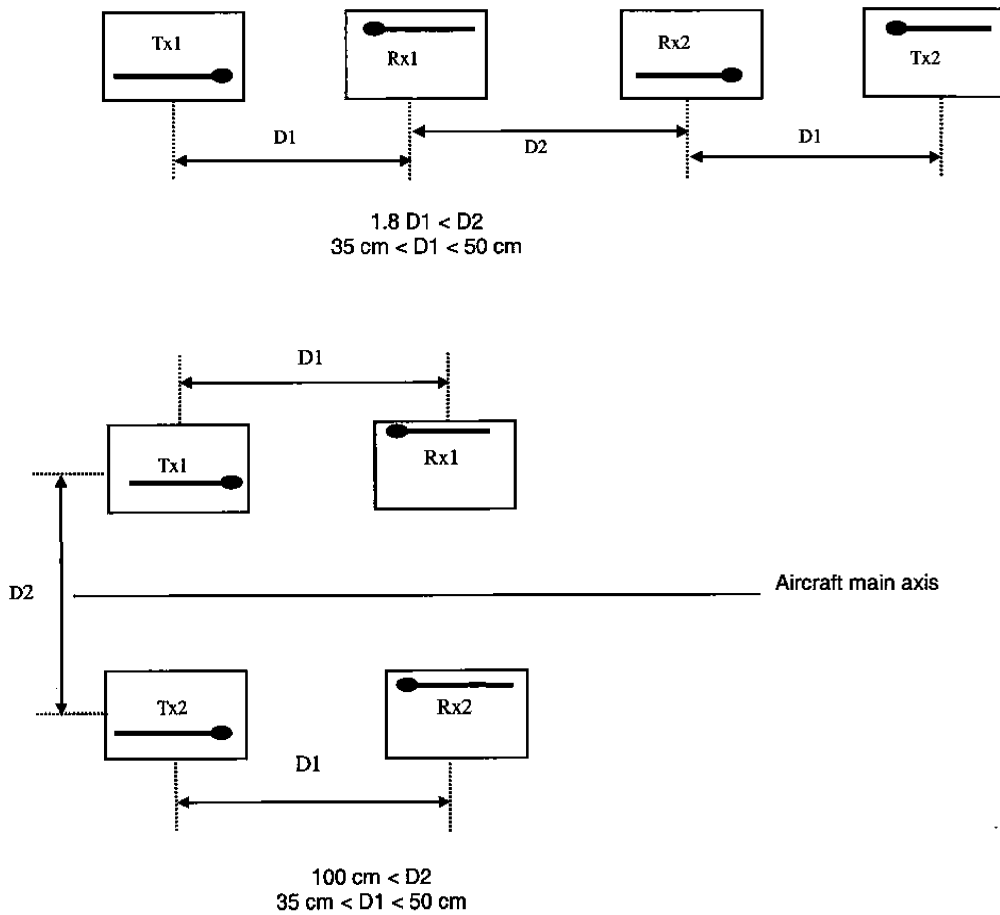

Figure 201 – ANT-140A – ANTENNAE SEPARATION AND ORIENTATION

B. ANTENNA MOUNTING

Antennae must be flush-mounted, from below, in the lower part of the aircraft fuselage.

Antennae connectors must imperatively face:

- forwards for the front antenna,
- rearwards for the rear antenna.

Each antenna bears a red ink marking to indicate assembly orientation into aircraft.

C. CONNECTION

The electrical connection for operational use of each antenna is made by means of a single coaxial connector.

Type of connector mounted on antenna: 50 ohm female coaxial type TNC connector conforming to specification MIL-C-39012.

3. VERIFICATION

When the AHV1600 Transceiver is installed, a verification of the operation must be done using the PBIT. This verification must be done in operational conditions.

A. GROUND TESTS

- Prior to install the transceiver, check all interfering for continuity and isolation,
- Install and connect the transceiver,
- Energise the equipment and check that the ARINC output message contains an altitude close to 0ft. Antenna to ground distance may differ in parked situation from the touch down, so this test altitude may vary slightly around 0 ft,
- Proceed to Functional Test, the ARINC output message shall contain an altitude of 0 ft exactly,
- Check that the coupling to other systems is correct.

B. IN FLIGHT TESTS

- Sensitivity versus altitude: check that the "loss track" altitude of the radio altimeter is greater than 5000 ft (No Computed Data indication on ARINC output message),
- Sensitivity versus attitude: Check that the track is not loss for ROLL and PITCH angles as defined by the half power antennae beamwidth.
- Immunity from track to landing gear down and the helicopter structure: when flying at an altitude higher than 1000 ft, impose the Functional Test mode. At release of the Functional Test, check that the track mode is recovered and the transceiver outputs a correct altitude different of 0 ft.
- 0 ft accuracy: at touch down landing, check that the radio altimeter indicates 0 ft.

4. FUNCTIONAL CONNECTIONS WITH RELATED EQUIPMENT**A. INTERFACES CONNECTIONS**

The following table displays the connector labels, the function, and the connector reference for all connectors used for the AHV1600 transceiver.

CONNECTOR LABEL	FUNCTION	CONNECTOR REFERENCE	MATING CONNECTOR REFERENCE
J1	Main connector	MIL C- 38999 / MS27468 T 15 B-35 PN (*)	MT934-T15B35P-M112
J2	To Antenna TX	MIL C 39012	34MMBX-TNC-50-1/1-2-NE
J3	To Antenna RX	MIL C 39012	34MMBX-TNC-50-1/1-2-NE

(*) Note: The MIL reference designates a connector including the main external characteristics:

- 37 pins,
- Shell size 15,
- Drab olive green finish,
- Male contacts,
- Normal polarization.

B. GROUNDING AND BONDING

The bottom part of the chassis is used as mechanical and electrical contact with the aircraft fuselage.

Figure 202 shows the surfaces providing bonding contact between the Transceiver chassis and the platform structure.

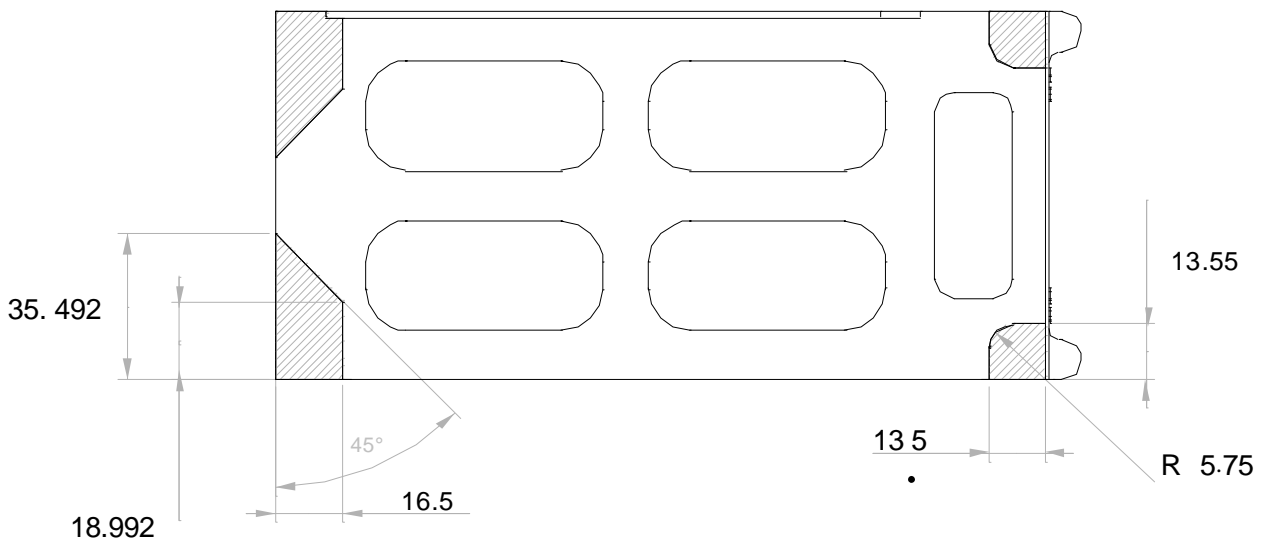

Nota : All dimensions are in mm.

Figure 202 – SURFACES BONDING CONTACT OUTLINES

C. COOLING OF THE EQUIPMENT

The AHV1600 on platform installation must take into account that heat dissipation for the Transceiver is partially accomplished through natural convection requiring a minimum space between the Transceiver and the next equipment of 10 mm.

The remained part of the heat is dissipated by conduction between the bottom part of the Transceiver chassis and the platform frame. The maximum heat dissipation is 20 watts.

D. HANDLING

No specific tools or support are required to handle or carry the Transceiver due to its small and prehensile dimensions and its lightweight.

The Transceiver is equipped with caps, which are plugged on each I/O connector, and which protect them from ESD, sand and dust.

5. EQUIPMENT INPUTS / OUTPUTS

A. MAIN CONNECTOR J1

Socket Contact	Contact Gauge	Input (I) / Output (O)	Signal Name	Wire Type	Installation Requirements
1	22D				Reserved
2	22D				Reserved
3	22D				Reserved
4	22D				Reserved
5	22D	I	FCT_TST	Simple see note 4	Discrete input signal
6	22D	I	TST_INH	Simple see note 4	Discrete input signal
7	22D				Reserved
8	22D				Reserved
9	22D	O	TX429_HI_1	Twisted/Shielded see note 2&3	Differential output serial line
10	22D	O	TX429_HI_1	Twisted/Shielded see note 2&3	Differential output serial line
11	22D				Reserved

Socket Contact	Contact Gauge	Input (I) / Output (O)	Signal Name	Wire Type	Installation Requirements
12	22D				Reserved
13	22D	O	TX429_HI_2	Twisted/Shielded see note 2&3	Differential output serial line
14	22D	O	TX429_HI_2	Twisted/Shielded see note 2&3	Differential output serial line
15	22D				Reserved
16	22D	I	AID2	Simple (as short as possible) see note 4	Configurable input signal
17	22D	I	P28V_1	Twisted see note 1	Power supply input 1
18	22D	I	P28V_2	Twisted see note 1	Power supply input 2
19	22D	I	RET28V_2	Twisted see note 1	Power supply return 2
20	22D	I	AID_P	Simple (as short as possible) see note 4	Configurable input signal
21	22D				Reserved
22	22D				Reserved
23	22D	I	AID 0	Simple (as short as possible) see note 4	Configurable input signal
24	22D	I	AID 1	Simple (as short as possible) see note 4	Configurable input signal
25	22D				Reserved
26	22D				Reserved
27	22D				Reserved
28	22D				Reserved
29	22D				Reserved
30	22D	I	RET28V_1	Twisted see note 1	Power supply return 1

Socket Contact	Contact Gauge	Input (I) / Output (O)	Signal Name	Wire Type	Installation Requirements
31	22D				Reserved
32	22D				Reserved
33	22D	O	E_GND		Electrical reference ground
34	22D	I	SDI_SEL	Simple (as short as possible) see note 4	Configurable input signal
35	22D				Reserved
36	22D				Reserved
37	22D				Reserved

Note 1 :Twisted wire type

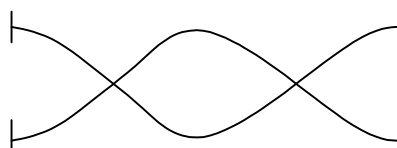

Note 2 : Twisted + Shielded wire type (shield shall be terminated at the connector EMI backshell)

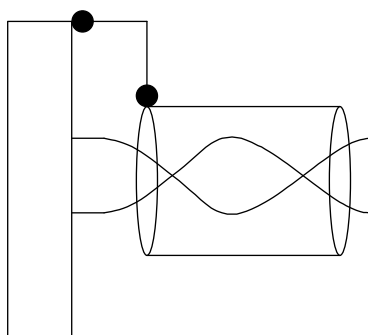

Note 3 :ARINC data bus A2 (12.5 KHz)

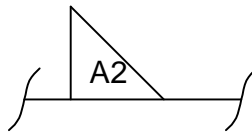

Note 4 : Simple wire type

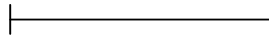

Note 5: The M_GND reference signal must be connected to the mechanical reference ground of the carrier

B. RX/TX ANTENNA

Connector Contact	Contact Gauge	Input (I) / Output (O)	Signal Name	Wire Type	Installation Requirements
RX	TNC	I	RX	Coaxial cable	Length according to AID selection
TX	TNC	O	TX	Coaxial cable	

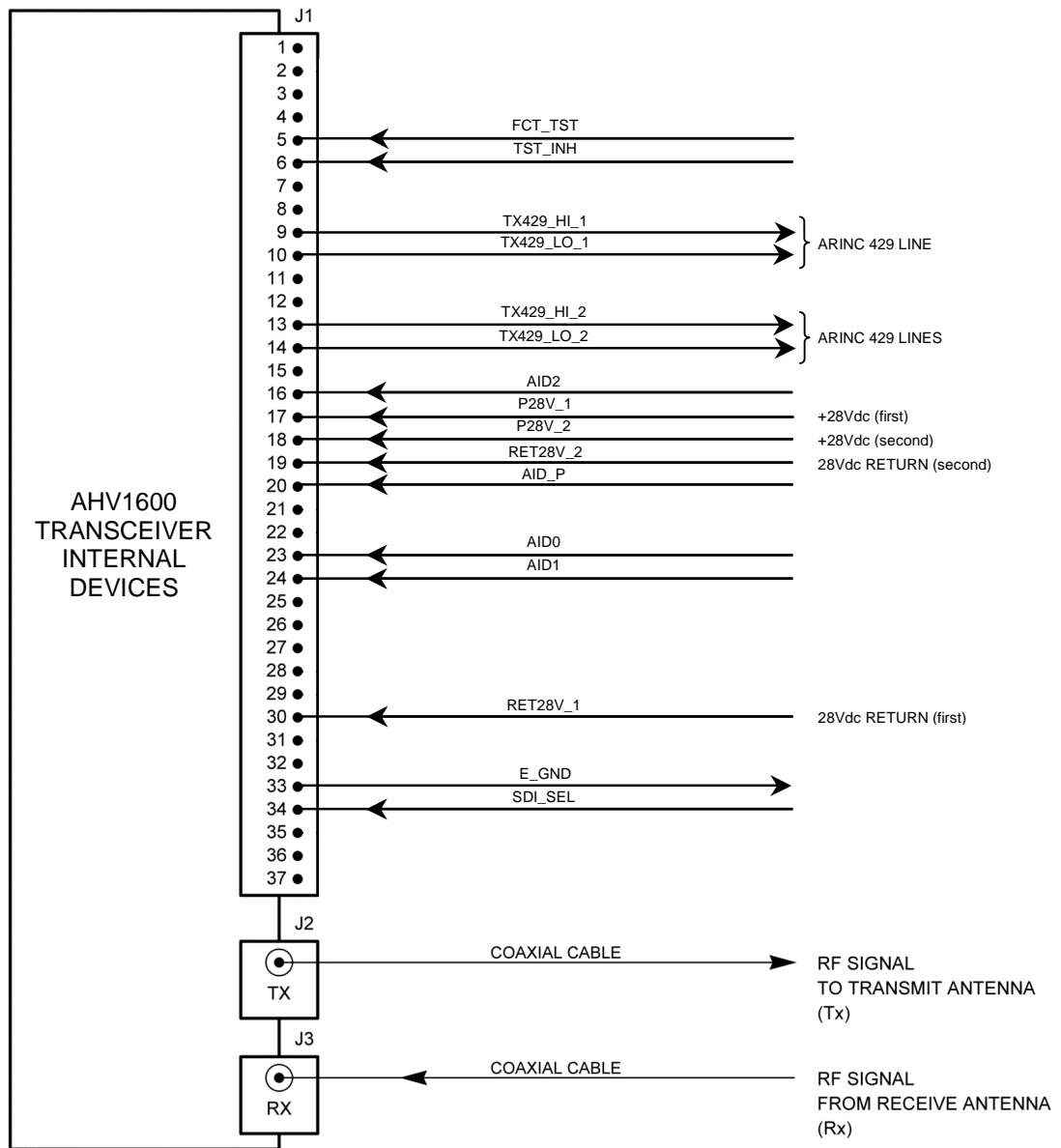

Figure 203 – INTERCONNECTIONS

OPERATION

1. RADAR ALTIMETER ENERGIZATION

The AHV1600 radar altimeter is not provided with an "ON-OFF" switch. The equipment starts operating as soon as the + 28 VDC power supply is applied by a circuit breaker or other mean located on the helicopter front panel.

2. FUNCTIONAL TEST

When the functional test is requested, the system shall outputs a 100 ft test height and functional test is indicated in the status matrix of word labels 164 and 165.

3. NORMAL OPERATING MODE

When on ground or flying in the system range, the radar altimeter shall output the helicopter height above the ground with the specified accuracy. Alarms shall be out of view.

The status matrix of ARINC 429 words shall indicate the Normal Operation status.

4. OUT OF RANGE OPERATION

When the helicopter is flying outside the system range (above 5000 ft), the radar altimeter shall enters in the loss of track mode (search mode).

The status matrix of ARINC 429 words shall indicate the No Computed Data status.

5. FAILURE MODE

When a failure is detected by the radar altimeter monitoring, when the helicopter is either on ground or flying, it is signalled.

The status matrix of ARINC 429 words shall indicate the Failure Warning status.

6. DEFAULT OPERATING INSTRUCTIONS

Default	Possible cause	Corrective action
No output data	- Radar altimeter not powered - Radar altimeter power supply failure - wiring	- Check circuit breaker - Change power supply module - Check wiring
Output data with Failure Warning status	- Radar altimeter failure	- Change transceiver
Output data with No Computed Data indication	- Loss of system sensitive when helicopter on ground or flying in the equipment operating range	- Check antennae installation - Change transceiver

7. OPERATIONAL LEVEL MAINTENANCE TASK

The Operational level maintenance task consists in removing and replacing the transceiver (LRU) in case of failure.

A. REMOVING THE TRANSCEIVER

Recommended removing flowchart:

- power-off the transceiver,
- disconnect the three cables from front panel,
- remove the four M6 screws which secure the unit onto the aircraft structure,
- remove the unit.

B. INSTALLING THE SPARE TRANSCEIVER

Refer to INSTALLATION § 2

Before installing the spare Transceiver, ensure the Transceiver location on aircraft structure is clean.