 THOMSON-CSF COMMUNICATIONS	Département Communications Hyperfréquences	ORIGINE / ISSUED	
		Etablissement / Plant	Emetteur / By
		TOULOUSE	DCH

HYP E R X

INSTALLATION MANUAL

Modular Readers

LML_3013 ; LML_3033 ; LVM_4033

Rédigé par / Written by : <i>W. Löbert</i> Service / Department : <i>Engineering</i> Signature / Sign : <i>W. Löbert</i> Approuvé par / Approved by : <i>Ph. Gobrecht</i> Service / Department : Signature / Sign : <i>Ph. Gobrecht</i> Autorisé par / Authorized by : Service / Department : Signature / Sign :	Nom / Name : Service / Department : Signature / Sign : Nom / Name : Service / Department : Signature / Sign : Nom / Name : Service / Department : Signature / Sign :	
Date de l'édition : Issue date : 19/06/1998	Archive :	Total pages 41

CLASSIFICATION SOCIETE/ CLEARANCE LEVEL NON	REFERENCES DU DOCUMENT / DOCUMENT REFERENCES					PAGE
	Code Fabricant / Manufact. Code	Numéro / Number	Code Doc / Doc. Code	Tome / Volume	Indice / Revision Index	

	Département Communications Hyperfréquences	ORIGINE / ISSUED	
		Etablissement / Plant	Emetteur / By
		TOULOUSE	DCH

EVOLUTIONS SUCCESSIVES / SUCCESSIVE CHANGES

INDICE / REVISION INDEX	DATE	MODIFIE PAR / CHANGED BY	OBJET / DESCRIPTION
A	06/98	W. Löbert	Création

--	--	--	--

CLASSIFICATION SOCIETE/ CLEARANCE LEVEL	REFERENCES DU DOCUMENT / DOCUMENT REFERENCES						PAGE
NON	Code Fabricant / Manufact. Code	Numéro / Number	Code Doc / Doc. Code	Tome / Volume	Indice / Revision Index	Langue Language	



	Département Communications Hyperfréquences	ORIGINE / ISSUED	
		Etablissement / Plant	Emetteur / By
		TOULOUSE	DCH

TABLE OF CONTENTS

1. GENERAL INFORMATION	5
1.1 CHARACTERISTICS AND PERFORMANCE	5
1.2 SPECIFICATIONS	5
1.3 INSTALLATION	6
1.3.1 Reader constituents	7
1.3.2 Module mounting	8
1.3.3 Mounting the antenna	9
1.4 EXTERNAL CONNECTIONS	11
1.4.1 Connection of microwave signals	11
1.4.2 Connecting power supply and communications to host	15
1.4.3 Power-up	18
1.5 INSTALLATION AND CONNECTION PROCEDURES FOR THE ASYNCHRONOUS LINKS	19
1.5.1 Electrical specifications	19
1.5.2 Cables	19
1.5.3 Line Termination	20
1.5.4 Electrical connections	20
1.5.5 Networking	20
1.6 OUTPUT CIRCUIT FOR OPEN-COLLECTOR INTERFACE	21
1.7 FCC NOTICE	23
2. VISUAL INTERFACE	24
2.1 CONTROL LAMPS	24
2.1.1 Module FSM	24
2.1.2 Module SHF	24
2.1.3 Module SAM or LAM	25
2.1.4 SPI Module	26
2.1.5 Antenna AT1 (LML_3013)	27
2.2 BUZZER	28
2.3 RESET BUTTON	28
3. READER CONFIGURATION	29
3.1 TTL INTERFACES : ISO2 ET WIEGAND	30
3.1.1 ISO2 Interface	30
3.1.2 Interface WIEGAND	30
3.1.3 Tag persistence	30
3.1.4 Minimum Time Between Messages (MTBM)	30
3.1.5 Tag message repetition	31
3.2 ASYNCHRONOUS SERIAL LINK	31
3.2.1 Address	31
3.2.2 Character Format and Baud rate	32
3.2.3 Protocol : polling or interrupt	32
3.2.4 Frame format	32
3.3 MESSAGE MODE	33
3.4 RELAY OPERATION	34
3.5 BUZZER OPERATION	35
3.6 CODE FILTERING WITH THE DISTRIBUTOR CODE	35
3.7 ELECTRICAL INTERFACE	35
3.8 READING RANGE	35
3.9 OPERATING CHANNEL	36

CLASSIFICATION SOCIETE/ CLEARANCE LEVEL NON	REFERENCES DU DOCUMENT / DOCUMENT REFERENCES						PAGE iii
	Code Fabricant / Manufact. Code	Numéro / Number	Code Doc / Doc. Code	Tome / Volume	Indice / Revision Index	Langue Language	

 THOMSON-CSF COMMUNICATIONS	Département Communications Hyperfréquences	ORIGINE / ISSUED	
		Etablissement / Plant	Emetteur / By
		TOULOUSE	DCH

4. ANNEXE A : SWITCH SETTINGS..... 38

5. ANNEXE B : SPECIAL MODES (TEST MODE AND MINITEL MODE) 40

CLASSIFICATION SOCIETE/ CLEARANCE LEVEL	REFERENCES DU DOCUMENT / DOCUMENT REFERENCES						PAGE
NON	Code Fabricant / Manufact. Code	Numéro / Number	Code Doc / Doc. Code	Tome / Volume	Indice / Revision Index	Langue Language	

1. General Information

1.1 Characteristics and Performance

HYPERX™ is a multi-tag dynamic identification system using microwaves. A 'reader' emits microwaves up to a distance of one or more meters, depending on model. When a tag enters this zone, it modulates this radiation, thereby sending its code back to the reader, which then processes the received signal and extracts the code.

The readers LML_3013 , LML_3033 and LVM_4033 are modular readers comprising of electronic modules assembled within a chassis. The antenna is external to the chassis, connected with two coaxial cables. The principal characteristics are :

- Hands-free Reader LML_3013, range 2 m (7 feet) and passing speeds up to 20 Km/h (15 mph).
- Hands-free Reader LML_3033, range 8 m (25 feet) and passing speeds up to 20 Km/h (15 mph).
- Hands-free Reader LVM_4033, range 5 m (16 feet) and passing speeds up to 100 Km/h (60 mph).
- Range adjustment by potentiometer
- Directive Microwave beam :
 - ◊ Virtually insensitive to environmental interference
 - ◊ Can be pointed to illuminate a particular area
 - ◊ Installation on metallic surface with no performance reduction
- Simultaneous identification of 5 tags in 1 second
 - ◊ Several tags can be present in identification zone, intentionally or not
- Identification in nearly all tag positions:
 - ◊ Back / Front
 - ◊ Horizontal / Vertical.
- Coexistence of 31 readers in same zone
 - ◊ access with successive access
 - ◊ access points close together
- Précautions
 - ◊ Human bodies and metallic objects between tag and antenna can obstruct identification
 - ◊ Close contact (<5 mm) between tag and body or with metallic surface can reduce reading range

1.2 Specifications

- | | |
|--|--------------------|
| • Chassis dimensions | 240 x 170 x 170 mm |
| • Chassis weight (with modules) LML_3013; LML_3033; LVM_4033 | 4,2 kg |
| • Antenna weight for LML_3013 (AT1) | 0,8 kg |
| • Antenna weight for LML-3033 ; LVM_4033 | 3 kg |
| • Power Supply | 12 VDC |

CLASSIFICATION SOCIETE/ CLEARANCE LEVEL	REFERENCES DU DOCUMENT / DOCUMENT REFERENCES						PAGE
	Code Fabricant / Manufact. Code	Numéro / Number	Code Doc / Doc. Code	Tome / Volume	Indice / Revision Index	Langue Language	
NON							

• Power consumption (max)	900 mA
• Band centre frequency	2,450 GHz
• Reading channels	31
• Data transmission rate between tag and reader	30 000 bits/s
• Error detection	HDLC
• Error rate of incorrect identifications	1 E-7
• Identification failure rate (dans les conditions normales d'utilisation)	1 E-4
• Radiated Power LML_3013	20 mW E.I.R.P.†
• Radiated Power LML_3033	75 mW E.I.R.P.
• Radiated Power LVM_4033	75 mW E.I.R.P.
• Performance LML_3013	2 meters / 15Km/h
• Performance LML_3033	8 meters / 40Km/h
• Performance LVM_4033	5 meters / 100Km/h
• Réglage de portée	yes
• Antenna beamwidth LML_3013	90°
• Antenna beamwidth LML_3033	45°
• Antenna beamwidth LVM_4033	45°
• Relay	24 VDC et 1 A

† : E.I.R.P. : Equivalent Isotropic Radiated Power

Environment :

• Operating temperature	-20°C à +70°C
• Storage temperature	-25°C à +80°C
• Relative humidity	90% non condensing
• Water Protection	IP55

1.3 Installation

The HYPER X™ modular readers consist of a watertight enclosure containing different combinations of modules depending on the model. The reading antenna is connected to the enclosure via two cables. The enclosure has a door and is equipped with a lock and key.

The modules in the box perform all the main functions : power supply, microwave emission and reception, signal processing.

The box can be fixed to a wall or mounted on a mast by means of four 6mm holes.

CLASSIFICATION SOCIETE/ CLEARANCE LEVEL	REFERENCES DU DOCUMENT / DOCUMENT REFERENCES						PAGE
	Code Fabricant / Manufact. Code	Numéro / Number	Code Doc / Doc. Code	Tome / Volume	Indice / Revision Index	Langue Language	
NON							

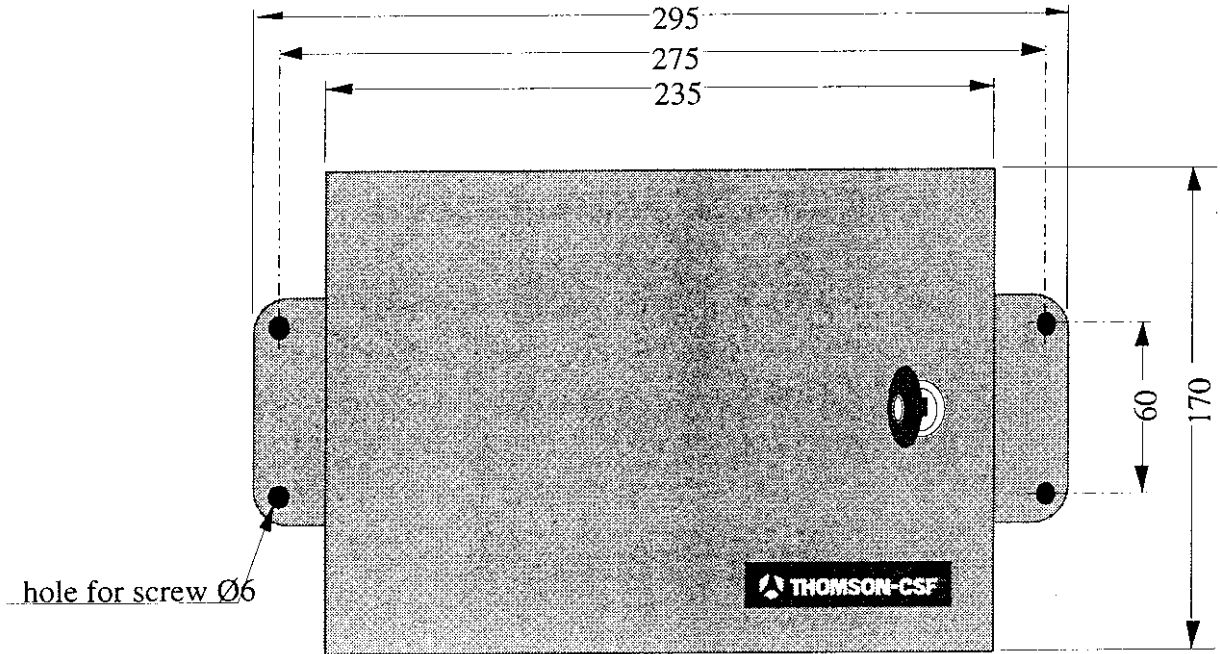

Chassis installation, in particular the electrical connection, must comply with appropriate standards in destination country. Dimensions are in mm.

1.3.1 Reader constituents

1.3.1.1 Modular reader LML_3013

Comprises :

- 1 antenna AT1_2709
- 1 chassis CHS_2019
- 1 microwave source SHF_2339
- 1 receiver module SAM_2419
- 1 CPU + communications interface SPI_2110
- 1 power supply module FSM_2550

1.3.1.2 Modular reader LML_3033

Comprises :

- 1 antenna AT3_2749
- 1 chassis CHS_2019

- 1 microwave source SHF_2339
- 1 receiver module SAM_2419
- 1 CPU + communications interface SPI_2110
- 1 +12 Vdc power supply module FSM_2550

1.3.1.3 Modular reader LML_4033

Comprises :

- 1 antenna AT3_2749
- 1 chassis CHS_2019
- 1 microwave source SHF_2339
- 1 receiver module LAM_2429
- 1 CPU + communications interface SPI_2110
- 1 +12 Vdc power supply module FSM_2550

1.3.2 Module mounting

1.3.2.1 Inserting modules into rack

The modules consist of printed circuit boards perpendicularly mounted behind a metallic front panel.

The enclosure contains a standard-size rack for Europe-size boards. To insert a module into the desired position, place the board edges in the guiding rails and push slowly until contact is made with the back panel. Push firmly home to insure correct contact. The front panel is now aligned with the top and bottom horizontal rack bars and can be fixed in place with 2 or 4 screws (depending on module).

In general, the modules are already installed upon delivery.

1.3.2.2 Module positions

The rear panel is divided into two halves :

- a left half for the power supply module
- the right half for the remaining modules

The **FSM** module must be in the left-most position.

All other modules must be situated to the right of the FSM module as follows :

- LML_3013 and LML_3033
- SHF** to the right of FSM
- SAM** to the right of SHF

SPI to the right of SAM.

- LVM_4033

SHF to the right of FSM

LAM to the right of SHF

SPI to the right of LAM.

1.3.3 Mounting the antenna

The antenna emits and receives microwaves for the purpose of tag identification, so the antenna must be correctly oriented towards an obstacle-free identification zone.

1.3.3.1 Antenna AT1_2709

The antenna has two parts :

- a plastic enclosure containing the printed circuit board, connected to two coaxial cables
- a wall-mounting plate in chromed steel

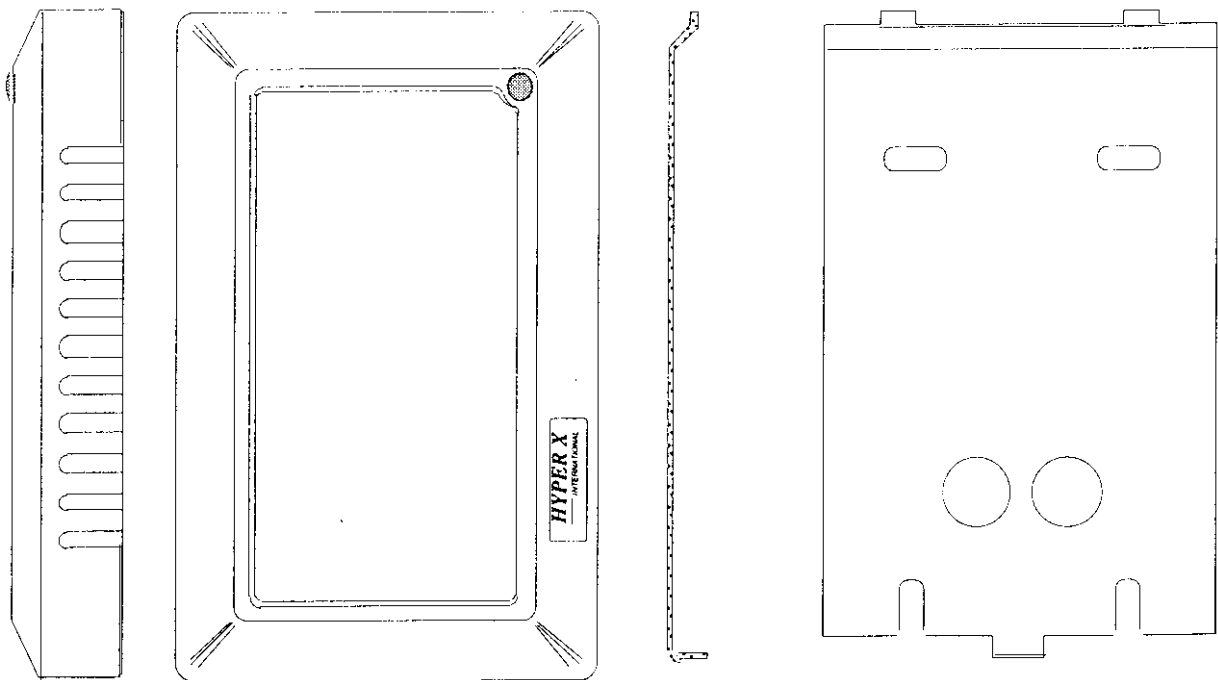

Antenna enclosure and mounting plate

CLASSIFICATION SOCIETE/ CLEARANCE LEVEL	REFERENCES DU DOCUMENT / DOCUMENT REFERENCES						PAGE
	Code Fabricant / Manufact. Code	Numéro / Number	Code Doc / Doc. Code	Tome / Volume	Indice / Revision Index	Langue Language	
NON							

The antenna cables are 5 m long and can leave the box at the bottom (if the cables are to run along the wall) or leave out the back through the two holes in the mounting plate (if the cables are to pass through a wall).

The antenna must be positioned so that the front-panel lamp is in the upper right-hand corner.

The mounting plate is first fixed with 2 or 4 screws (not supplied). Once this is in place, then the housing is attached and fixed into place with a small screw on the underside.

1.3.3.2 Antenna AT3_2749

This is an antenna in a watertight enclosure with two 5 m cables exiting at the rear.

Four Ø8 mm bolts with nuts for mounting are provided at the rear of the antenna.

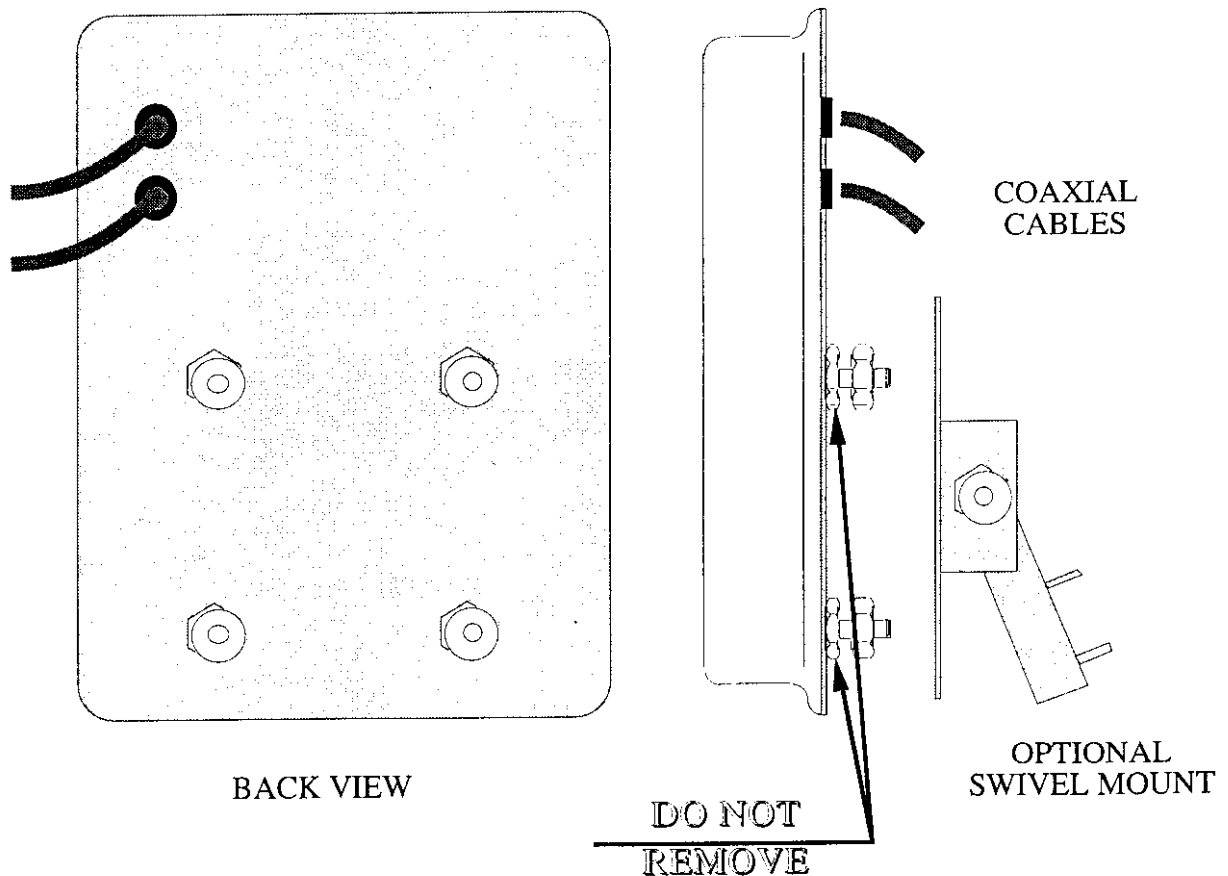

The antenna can be fixed to a Ø 50 mm mast using a swivel mount (option ACS-2733) which is attached to the four bolts. This allows optimal pointing adjustment (azimuth and elevation).

The use of this swivel mount is strongly recommended.

CLASSIFICATION SOCIETE/ CLEARANCE LEVEL	REFERENCES DU DOCUMENT / DOCUMENT REFERENCES						PAGE
	Code Fabricant / Manufact. Code	Numéro / Number	Code Doc / Doc. Code	Tome / Volume	Indice / Revision Index	Langue Language	
NON							

It is however possible to mount the antenna on any appropriate support. The four bolts are located at the corners of a 120 mm square.

Warning: Do not remove the lower nuts which fix the bolts onto the metal plate. Only the upper nuts must be used for antenna mounting.

1.4 External Connections

Connections to the reader are of two types :

- coaxial cables with BNC connectors for microwave signals
- small-gauge wire with screw-terminal connectors for DC supply and data signals

1.4.1 Connection of microwave signals

1.4.1.1 Cables

All cables for microwaves, for connections between modules and between chassis and antenna, are supplied with the reader.

These coaxial cables have a fixed known impedance, are relatively stiff and must not be bent (restrictions on bending radius).

1.4.1.2 BNC Connectors

Cable ends have male BNC connectors. Modules are equipped with female BNC connectors.

The two connectors must be properly locked together (push in then turn) in order to insure a good connection.

The enclosure door should be locked (with key) in order to prevent cable disconnection.

PAGE 11	CLASSIFICATION SOCIETE/ CLEARANCE LEVEL		REFERENCES DU DOCUMENT / DOCUMENT REFERENCES				
	NON		PROTEGE				
Code Fabricant / Manufact. Code		Numéro / Number		Code Doc / Doc. Code		Tome / Volume	
F0057		46 322 782		108		E	
		Langue		Revision Index / Indice /		Langue	

1.4.1.3 Connection of modules SHF and SAM (or LAM)

The SHF module must be connected to the SAM module (or LAM depending on the model) using the short coaxial cable supplied. The two connectors are identified with a white "RF" marking in a black circle (see diagram below).

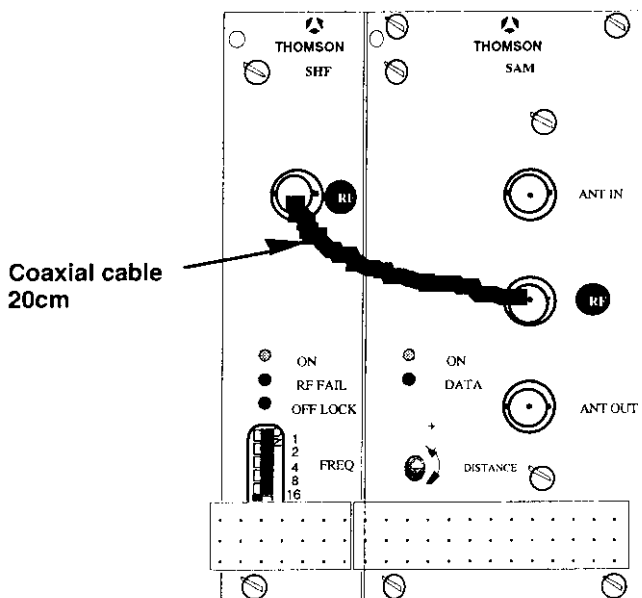

1.4.1.4 Connection of antenna to module SAM or LAM

The antenna has 2 cables terminated in male BNC connectors. The cable ends bear the following inscriptions :

For reception : "ANT IN" or "I"

For emission : "ANT OUT" or "O"

The corresponding BNC connectors on the SAM (LAM) front panel are also labelled "ANT IN" and "ANT OUT".

Be sure to make the right connections : "ANT IN" on cable to "ANT IN" on front panel.

In case the cable markings are not present or have come off, the "ANT IN" cable has a black ring at its end and the "ANT OUT" cable a red ring.

Inverting the cables will cause the reader to malfunction.

CLASSIFICATION SOCIETE/ CLEARANCE LEVEL	REFERENCES DU DOCUMENT / DOCUMENT REFERENCES						PAGE
NON	Code Fabricant / Manufact. Code	Numéro / Number	Code Doc / Doc. Code	Tome / Volume	Indice / Revision Index	Langue Language	

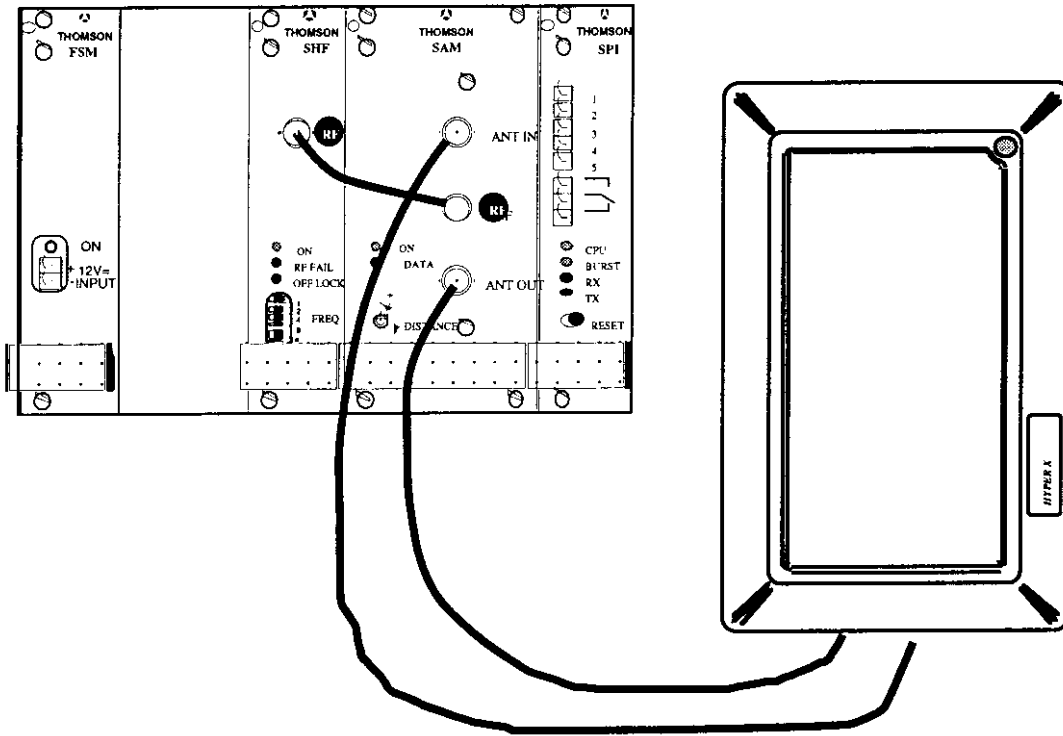

Coaxial cable connections

Before connecting the antenna cables, they must be passed through the appropriate holes in the bottom of the reader enclosure. After connecting the cables to the BNC connectors on the modules, the cable grommets must be positioned on the cable so that they can be covered by the wire mesh shielding. The cable is then manoeuvred into place with the grommet firmly in place in the enclosure hole and the mesh sticking out as shown in the diagram below.

CLASSIFICATION SOCIETE/ CLEARANCE LEVEL	REFERENCES DU DOCUMENT / DOCUMENT REFERENCES						PAGE
	Code Fabricant / Manufact. Code	Número / Number	Code Doc / Doc. Code	Tome / Volume	Indice / Revision Index	Langue Language	
NON							12

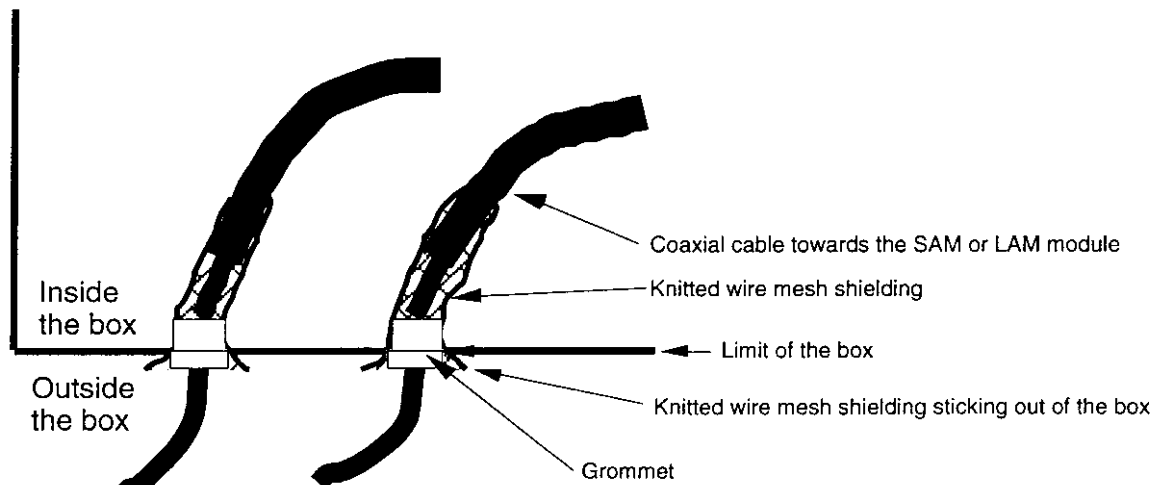
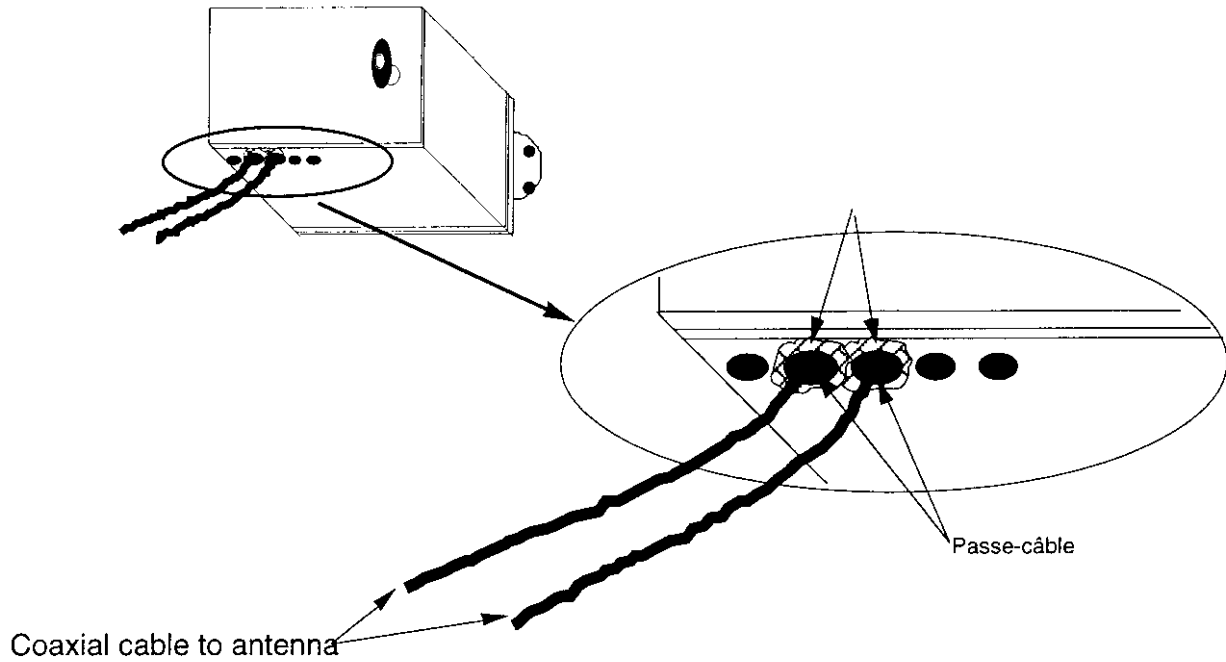

With all modules in place and connected to their cables, the door must be closed and locked so that the antenna cannot be disconnected.

CLASSIFICATION SOCIETE/ CLEARANCE LEVEL	REFERENCES DU DOCUMENT / DOCUMENT REFERENCES						PAGE
	Code Fabricant / Manufact. Code	Numéro / Number	Code Doc / Doc. Code	Tome / Volume	Indice / Revision Index	Langue Language	
NON							

1.4.2 Connecting power supply and communications to host

1.4.2.1 12V Power Supply

Power is supplied via a 2-pin plug (supplied). The plug has screw terminals to which the two wires are connected :

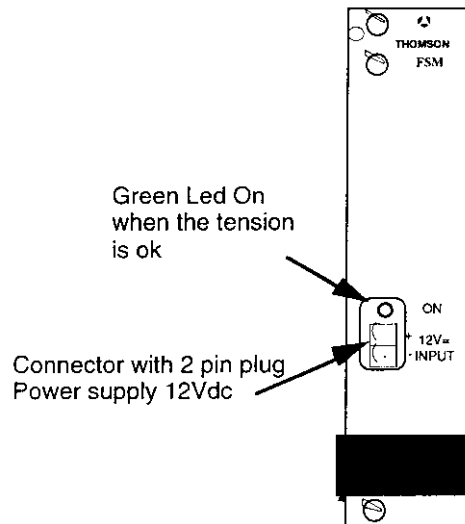

Pin	Name
+	+12Vdc
-	0V

Power consumption for the whole reader is typically 700 mA / 12 V .

Wires (copper) used must be minimum 1.5 mm₂ (AWG 15).

For long wires, voltage drop may be significant. It should be checked that input voltage at the FSM connector lies within 11.5 V and 15 V. Noise and hum should be less than 50 mVrms.

For the readers LML_3033 and LVM_4033, the supply wires must be equipped with a ferrite bead, located on the cable portion inside the enclosure (ref Steward : 28B2029-0A0 or equivalent).

CLASSIFICATION SOCIETE/ CLEARANCE LEVEL	REFERENCES DU DOCUMENT / DOCUMENT REFERENCES						PAGE
	Code Fabricant / Manufact. Code	Numéro / Number	Code Doc / Doc. Code	Tome / Volume	Indice / Revision Index	Langue Language	
NON							

1.4.2.2 Connection of relay on SPI module

Relay connection is via a 3-pin plug (supplied). The plug has screw terminals to which the three wires are connected :

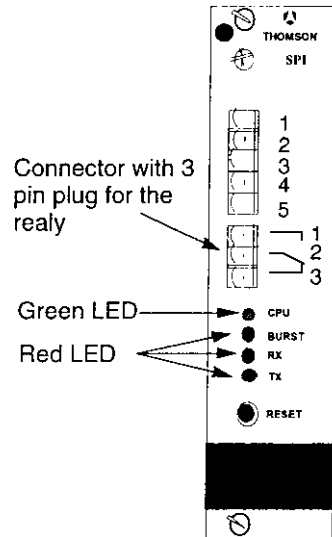

Pin	Name	I/O
1	Make	O
2	Common	I
3	Break	O

The relay is energised by on-board software. When it is not energised, pins 2 and 3 are connected, when it is energised, pins 1 and 2 are connected.

NOTE: This relay is designed to switch only 24 VDC / 1 A. In order to switch mains circuits, an external relay must be used.

1.4.2.3 Link from SPI to host

The reader end of the cable connection to host is made with a 5-pin screw-terminal plug (supplied). This cable type typically uses AWG22 wire and must be shielded.

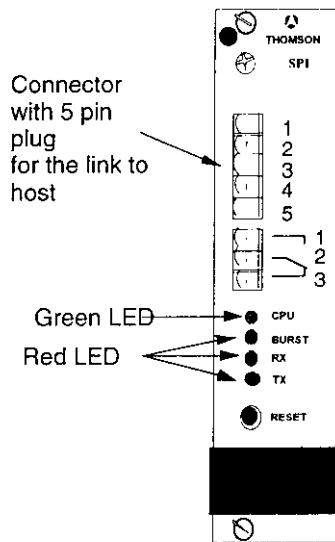

Pin	Name	I/O
1	O1	I/O
2	O2	I/O
3	O3	I/O
4	O4	I
5	GND	

Pins O1 to O4 are associated with different signals depending on the type of link :

Name	RS-232	RS-422	RS485	ISO2	WIEGAND
O1	TX	TX+	+V	STROBE	DATA '1'
O2	--	TX-	-V	MDATA	DATA '0'
O3	--	RX+	--	PRES BADGE	--
O4	RX	RX-	--	--	--
O5	GND	GND	GND	GND	GND

The shielding braid must be connected to the chassis with a terminal of type 'fast-on' doubly-crimped.

CLASSIFICATION SOCIETE/ CLEARANCE LEVEL	REFERENCES DU DOCUMENT / DOCUMENT REFERENCES						PAGE
	Code Fabricant / Manufact. Code	Numéro / Number	Code Doc / Doc. Code	Tome / Volume	Indice / Revision Index	Langue Language	
NON							

For the readers LML_3013, LML_3033 and LVM_4033, this cable must be equipped with a ferrite bead, located on the cable portion inside the enclosure (ref Steward : 28B2029-0A0 or equivalent).

1.4.3 Power-up

Power may be applied once all modules are inserted and all cables connected.

Correct operation of each module can be determined by checking the lamps on each module's front panel :

For the LML 3013 :

FSM	lamp "ON" is green
SHF	lamp "ON" is green
SAM	lamp "ON" is green
SPI	lamp "CPU" is green and slowly blinking
AT1	green and regular blinking

For the LML 3033 :

FSM	lamp "ON" is green
SHF	lamp "ON" is green
SAM	lamp "ON" is green
SPI	lamp "CPU" is green and slowly blinking

For the LML 3033 :

FSM	lamp "ON" is green
SHF	lamp "ON" is green
LAM	lamp "ON" is green
SPI	lamp "CPU" is green and slowly blinking

CLASSIFICATION SOCIETE/ CLEARANCE LEVEL	REFERENCES DU DOCUMENT / DOCUMENT REFERENCES						PAGE
NON	Code Fabricant / Manufact. Code	Numéro / Number	Code Doc / Doc. Code	Tome / Volume	Indice / Revision Index	Langue Language	

1.5 Installation and connection procedures for the asynchronous links

1.5.1 Electrical specifications

- Interface RS-232 :

Input (RX)	Input voltage range	- 30V min, + 30V max
	V _{IL} threshold	1,2V typ
	V _{IH} threshold	1,7V typ
Output (TX)	Output voltage	± 5V min, ± 9V typ

- Interface RS-422 :

Input (RX)	Common-mode voltage	± 7V max
	Differential-mode voltage	± 12V max
	V _{IH} threshold	2V min
	V _{IL} threshold	0,8V max
Output (TX)	V _{OH} (I _{OL} = -20mA)	2.5V min
	V _{OH} (I _O = 0)	5V
	V _{OL} (I _{OL} = 48mA)	0.5V max
	V _{OL} (I _O = 0)	0V
	Differential voltage V _{OD1} (I _O = 0)	2V min, 5V max
	Differential voltage (R _L = 100Ω)	0.5V _{OD1} (2V min)
	Common-mode voltage (R _L = 100Ω)	±3V max

- Interface RS-485 : Identical to RS-422

1.5.2 Cables

The reader end of the cable connection to host is made with a 5-pin screw-terminal plug (supplied). This cable type typically uses AWG22 wire and must be shielded.

The cable's shielding braid must be fastened to the chassis with a doubly-crimped 'fast-on' terminal.

CLASSIFICATION SOCIETE/ CLEARANCE LEVEL	REFERENCES DU DOCUMENT / DOCUMENT REFERENCES						PAGE
	Code Fabricant / Manufact. Code	Numéro / Number	Code Doc / Doc. Code	Tome / Volume	Indice / Revision Index	Langue Language	
NON							

For the readers LML_3013, LML_3033 and LVM_4033, this cable must be equipped with a ferrite bead, located on the cable portion inside the enclosure (ref Steward : 28B2029-0A0 or equivalent).

1.5.3 Line Termination

For a simplex link, the termination (if present) should be placed at the receiving end of the line.

For a duplex link, the termination (if present) should be placed at the each end of the line.

For baud rates less than 1200 bauds, no termination is necessary. For baud rates greater than 9600 bauds and line lengths greater than 1000 metres, a resistor equal to the line impedance (120 ohms) is usually necessary. For cases in-between, there is no clear-cut rule and depends on individual installations (combination of baud-rate, line-length, cable quality, emitter/receiver characteristics).

1.5.4 Electrical connections

For an RS-232 link, wiring up is straightforward, the TX and RX lines of both equipments are connected together.

For a differential link (RS-422 or RS-485), the polarities are not always clearly defined. Normally the "+" line is at a high level at rest and is active low. For the "-" line, the opposite is true. This is the case for the differential interface for the HYPERX readers. However if the differential signals are generated by a converter acting on RS-232 signals, then the "+" line can be at a low level at rest and active high. In this case, the "+" line of one equipment must be connected to the "-" line of the other equipment.

Connection of 0V

Whether this is necessary or not, depends on the installation. If host and reader are distant with different local ground potentials, then an RS-232 link may not work if the 0V references are not connected. However connecting them will cause ground currents to circulate. In general, for large link lengths, a differential link should be used. This also tolerates a large common-mode voltage difference.

1.5.5 Networking

1.5.5.1 Topologies

The preferred topology is the bus.

CLASSIFICATION SOCIETE/ CLEARANCE LEVEL	REFERENCES DU DOCUMENT / DOCUMENT REFERENCES						PAGE
NON	Code Fabricant / Manufact. Code	Numéro / Number	Code Doc / Doc. Code	Tome / Volume	Indice / Revision Index	Langue Language	

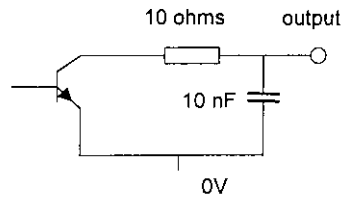

These links require the connection of an external resistance at the receiving end of the link.

For connecting to a +5V supply, use a 470 Ω resistor.

For connecting to a +12V supply, use a 1 K Ω resistor.

CLASSIFICATION SOCIETE/ CLEARANCE LEVEL	REFERENCES DU DOCUMENT / DOCUMENT REFERENCES						PAGE
	Code Fabricant / Manufact. Code	Numéro / Number	Code Doc / Doc. Code	Tome / Volume	Indice / Revision Index	Langue Language	
NON							
PROTEGE							

2. Visual Interface

2.1 Control Lamps

If one or more front-panel lamps are on, then the reader is powered up.

2.1.1 Module FSM

A green lamp indicates that the reader is correctly powered.

2.1.2 Module SHF

The SHF module has 3 lamps :

- a green lamp 'ON' indicating that power is on
- a red lamp 'RF FAIL' indicating that microwave power out is incorrect
- a red lamp 'OFF LOCK' indicating that there is a problem with the microwave frequency channel

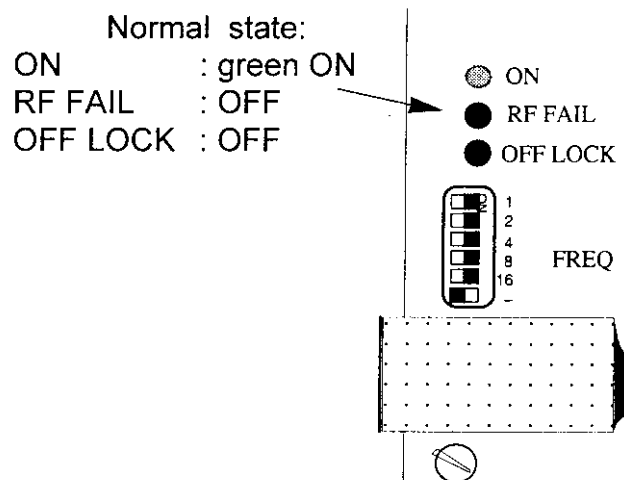

For correct operation :

- the 'ON' lamp is on (green)
- the 'RF FAIL' lamp is off
- the 'OFF LOCK' lamp is off

CLASSIFICATION SOCIETE/ CLEARANCE LEVEL	REFERENCES DU DOCUMENT / DOCUMENT REFERENCES						PAGE
NON	Code Fabricant / Manufact. Code	Numéro / Number	Code Doc / Doc. Code	Tome / Volume	Indice / Revision Index	Langue Language	

2.1.3 Module SAM or LAM

The SAM (or LAM) module has 2 lamps :

- a green lamp 'ON' indicating that power is on
- a red lamp 'DATA' indicating the presence of a data signal

Normal state:
ON : Green ON

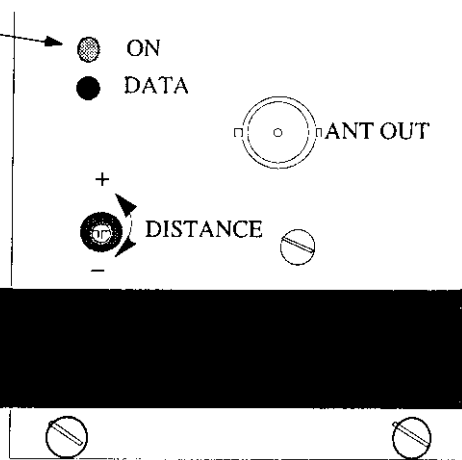

For correct operation :

- the 'ON' lamp is on (green)
- the 'DATA' lamp can be on or off (this lamp presents no useful user information)

CLASSIFICATION SOCIETE/ CLEARANCE LEVEL	REFERENCES DU DOCUMENT / DOCUMENT REFERENCES						PAGE
NON	Code Fabricant / Manufact. Code	Numéro / Number	Code Doc / Doc. Code	Tome / Volume	Indice / Revision Index	Langue Language	

2.1.4 SPI Module

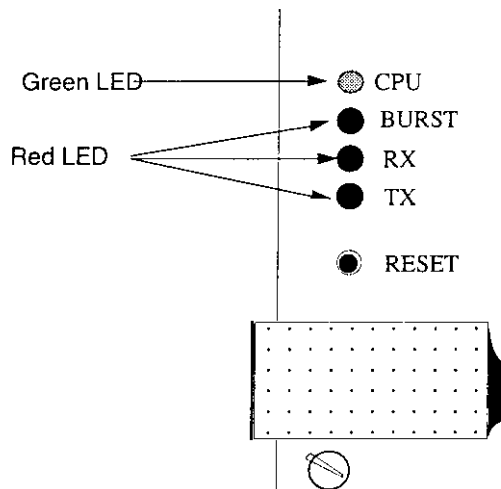

Four leds indicate the state of the module and tag activity.

- **Processor LED (CPU)**

This green LED can have one of two flashing rates :

- ◊ slow, roughly 0.5s on 0.5s off, indicating all modules are working normally.
- ◊ fast, roughly 0.05s on 0.05s off, indicating a problem with one of the modules in the rack.

Any other behaviour indicates faulty processor operation.

NB : If the reset button is held down, this LED should be on.

- **Tag activity (BURST)**

This red LED flashes (50 ms) to indicate that a tag has been detected by the reader.

- **Sending message (TX)**

This red LED indicates electrical activity on the front panel connector line 01 (TX for the RS-232/422/485 link). It is permanently on in the case of the interfaces ISO2 and WIEGAND.

- **Receiving message (RX)**

This red LED indicates electrical activity on the front panel connector line 04 (RX for the RS-232/422/485 link).

CLASSIFICATION SOCIETE/ CLEARANCE LEVEL	REFERENCES DU DOCUMENT / DOCUMENT REFERENCES						PAGE
NON	Code Fabricant / Manufact. Code	Numéro / Number	Code Doc / Doc. Code	Tome / Volume	Indice / Revision Index	Langue Language	

2.1.5 Antenna AT1 (LML_3013)

The antenna AT1 has a two-coloured lamp in the upper right corner. When the reader box is closed, this is the only visible signal that the user perceives. The lamp is under reader-software control, either in automatic mode or controlled by the host via the serial link.

Normal operation is a slow blink (0.5 s on, 0.5 s off) with the lamp remaining off for 1 second when a tag is first detected.

The state diagram below shows the different possible states during power-up (or after a processor rest) and their meaning.

State Diagram :

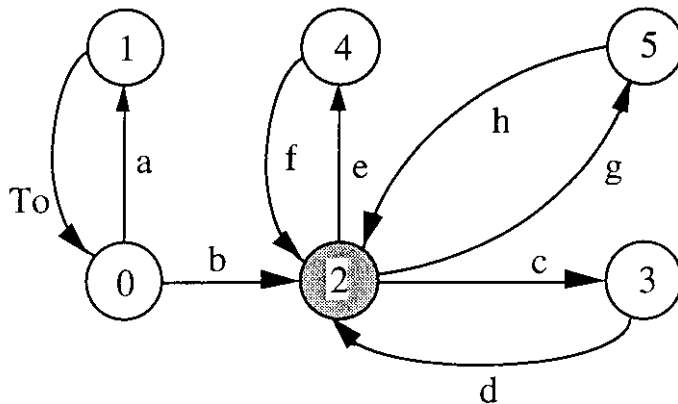

Events :

- a. internal hardware fault detected
- b. autotest OK
- c. module fault detected
- d. module fault disappears
- e. internal hardware fault detected
- f. internal hardware fault disappears
- g. received command "turn reader off"
- h. received command "turn reader on"

State	Name	Antenna LED	Emission	CPU LED	status word	
					ds	dm
0	Test	red, fixed	off	on	nd ²	nd
1	Hardware fault	see note 1	off	fast blink	0	nd
2	Normal	green, regular blink	on	slow blink	1	1
3	Module fault	green, irregular blink	on	fast blink	1	0
4	Reader not ready	red, slow blink	off	fast blink	0	x ³
5 ⁴	Reader OFF	off	off	slow blink	x	x
6 ⁵	Tag detected	off	off	x	1	x

CLASSIFICATION SOCIETE/ CLEARANCE LEVEL	REFERENCES DU DOCUMENT / DOCUMENT REFERENCES						PAGE
	Code Fabricant / Manufact. Code	Numéro / Number	Code Doc / Doc. Code	Tome / Volume	Indices / Revision index	Langue Language	
NON PROTEGE	E0057	46 322 782	108			F	27

3.1.5 Tag message repetition

Position 3 of J3 must be as follows :

3	Repetition
OFF	disabled
ON	enabled

3.2 Asynchronous serial link

3.2.1 Address

The module's physical address is the logical slave address that the host application software uses to address the module.

The four positions 1 to 4 of J4 determine the physical address:

4	3	2	1	Address
ON	ON	ON	ON	MINITEL
ON	ON	ON	OFF	1
ON	ON	OFF	ON	2
ON	ON	OFF	OFF	3
ON	OFF	ON	ON	4
ON	OFF	ON	OFF	5
ON	OFF	OFF	ON	6
ON	OFF	OFF	OFF	7
OFF	ON	ON	ON	8
OFF	ON	ON	OFF	9
OFF	ON	OFF	ON	10
OFF	ON	OFF	OFF	11
OFF	OFF	ON	ON	reserved use
OFF	OFF	ON	OFF	ISO2
OFF	OFF	OFF	ON	WIEGAND
OFF	OFF	OFF	OFF	ISO2

NB : A JBUS command message which has a slave address equal to 0 corresponds to a broadcast message, which explains why a reader cannot have an address of 0 for polling applications.

CLASSIFICATION SOCIETE/ CLEARANCE LEVEL	REFERENCES DU DOCUMENT / DOCUMENT REFERENCES						PAGE
	Code Fabricant / Manufact. Code	Numéro / Number	Code Doc / Doc. Code	Tome / Volume	Indice / Revision Index	Langue Language	
NON PROTEGE	F0057	46 322 782	108			F	31

3.2.2 Character Format and Baud rate

Baud rate is chosen using positions 5 and 6 of **J4**:

6	5	Baud rate
ON	ON	9600 Baud
ON	OFF	4800 Baud
OFF	ON	1200 Baud
OFF	OFF	19200 Baud

Format is chosen using positions 7 and 8 of **J4**:

8	7	Format
ON	ON	7 bits data 1 bit even parity
ON	OFF	7 bits data 1 bit odd parity
OFF	ON	8 bits data no parity
OFF	OFF	not used

3.2.3 Protocol : polling or interrupt

The type of protocol, polled or by interrupt, is chosen with position 5 on **J3** :

5	Protocol
OFF	Interrupt
ON	Polling

3.2.4 Frame format

Position 8 on **J3** determines the frame format, ASCII text or JBUS (binary).

	frame format
OFF	Test - ASCII text
ON	Normal - JBUS frame

The test format allows connection to a dumb terminal for easy on-site display.

3.3 Message mode

The mode is chosen using positions 1 and 2 on J3 . The mode determines in what cases the detection of a tag causes a message to be transmitted to the host.

Type 0 - Each time a tag is detected, a timer is armed (nominal value = 1s). Tag detection only causes a message to be transmitted if this timer is not active. Each tag detected has a timer associated with it.

Type 1 - This mode is no longer supported

Type 2 - At each tag detection, a message is transmitted to host. During message transmission, microwave emission is switched off. Only available for the ISO2 interface and the asynchronous start/stop interface in the interrupt mode.

Type 3 - When a tag "disappears" (is removed from internal memory), an extra message is transmitted to host which includes the tag's code as well as the number of times that the badge was detected. This number cannot be greater than 99. Not available for the Wiegand interface. Otherwise identical to type 0.

2	1	message mode
OFF	OFF	Type 3
OFF	ON	Type 2
ON	OFF	Type 1 - no longer supported
ON	ON	Type 0

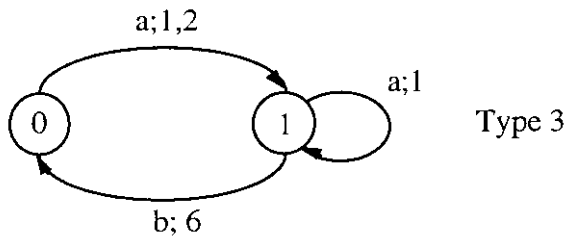
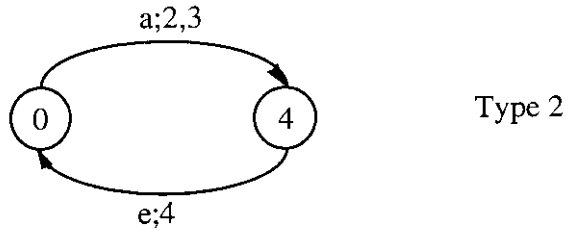
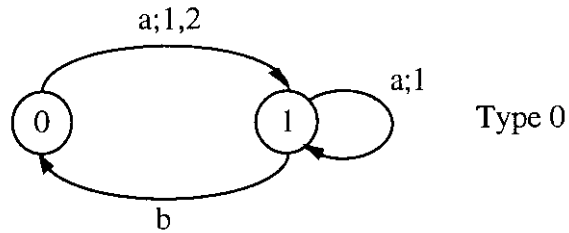

Events

a : tag is detected
 b : timeout anti reread
 e : message is sent

Actions

1 : arm anti reread timer
 2 : start message transmission
 3 : turn off reader
 4 : turn on reader
 6 : send tag disappearance message

Flow Graph describing the three message transmission modes

3.4 Relay operation

When a tag is detected, the relay operates. The switch in position 3 on J3 determines one of two modes of deactivation (for ISO2 and Wiegand, deactivation is automatic) :

- automatic relay deactivation after 2 second delay
- relay deactivation controlled by host via JBUS

CLASSIFICATION SOCIETE/ CLEARANCE LEVEL	REFERENCES DU DOCUMENT / DOCUMENT REFERENCES						PAGE
	Code Fabricant / Manufact. Code	Numéro / Number	Code Doc / Doc. Code	Tome / Volume	Indice / Revision Index	Langue Language	
NON							24

J3 n°3	Deactivation
OFF	Automatic
ON	Under host control via J-BUS

3.5 Buzzer operation

The switch in position 4 on **J3** activates or deactivates the buzzer on tag detection. When enabled, the buzzer emits a short sound (duration 50 ms) each time a tag is read.

J3 n°4	Buzzer
OFF	Enabled
ON	Disabled

When enabled, the buzzer sounds for 50 ms at every tag detection.

3.6 Code filtering with the Distributor code

The switch in position 6 on **J3** enables or disables this feature. A description is given in chapter ?. Applies only to ISO2 and asynchronous interfaces. For the WIEGAND interface this feature is automatically enabled.

6	Filtering
OFF	Disabled
ON	Enabled

3.7 Electrical interface

The switch in position 7 on **J3** enables or disables this feature. A description is given in chapter ?. This feature must be disabled for single readers.

Type	Position J1 and J2
RS-232	1, 11
RS-422	2, 4, 9, 10, 12
RS-485	2, 4, 6, 7, 12
ISO2	3, 5, 8
WIEGAND	3, 5, 8
Minitel	2

3.8 Reading range

This can be performed but is not recommended, the factory setting is for the maximum reading range.

3.9 Operating Channel

Example :
Channel '0'

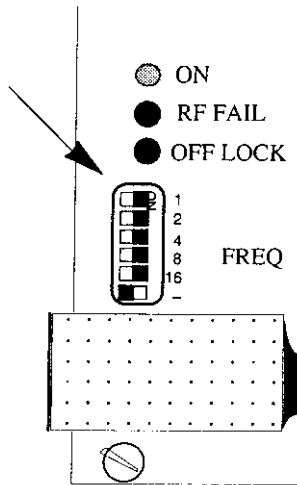

The reader can operate using 31 different channels. Each channel corresponds to a separate microwave frequency band. This is useful when several readers must be positioned close together. Using different channels on each reader eliminates mutual interference. The SHF module has 6 small switches on the front panel allowing a selection of 31 different channels (switch 6 is not used and 2 channels - 0 and 9 - are identical and use the same frequency).

Channel selection for the module SHF_2339 (the OFF position for switches are indicated by a blank in order to make the table more readable):

CLASSIFICATION SOCIETE/ CLEARANCE LEVEL	REFERENCES DU DOCUMENT / DOCUMENT REFERENCES						PAGE
	Code Fabricant / Manufact. Code	Numéro / Number	Code Doc / Doc. Code	Tome / Volume	Indice / Revision Index	Langue Language	
NON							

-	16	8	4	2	1	Channel
x	ON	ON	ON	ON	ON	0
x	ON	ON	ON	ON	-	1
x	ON	ON	ON	-	ON	2
x	ON	ON	ON	-	-	3
x	ON	ON	-	ON	ON	4
x	ON	ON	-	ON	-	5
x	ON	ON	-	-	ON	6
x	ON	ON	-	-	-	7
x	ON	-	ON	ON	ON	8
x	ON	-	ON	ON	-	9
x	ON	-	ON	-	ON	10
x	ON	-	ON	-	-	11
x	ON	-	-	ON	ON	12
x	ON	-	-	ON	-	13
x	ON	-	-	-	ON	14
x	ON	-	-	-	-	15
x	-	ON	ON	ON	ON	16
x	-	ON	ON	ON	-	17
x	-	ON	ON	-	ON	18
x	-	ON	ON	-	-	19
x	-	ON	-	ON	ON	20
x	-	ON	-	ON	-	21
x	-	ON	-	-	ON	22
x	-	ON	-	-	-	23
x	-	-	ON	ON	ON	24
x	-	-	ON	ON	-	25
x	-	-	ON	-	ON	26
x	-	-	ON	-	-	27
x	-	-	-	ON	ON	28
x	-	-	-	ON	-	29
x	-	-	-	-	ON	30
x	-	-	-	-	-	31

CLASSIFICATION SOCIETE/ CLEARANCE LEVEL	REFERENCES DU DOCUMENT / DOCUMENT REFERENCES						PAGE
NON	Code Fabricant / Manufact. Code	Número / Number	Code Doc / Doc. Code	Tome / Volume	Indice / Revision Index	Langue Language	

4. Annexe A : Switch Settings

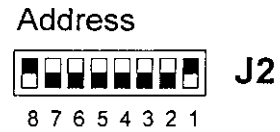
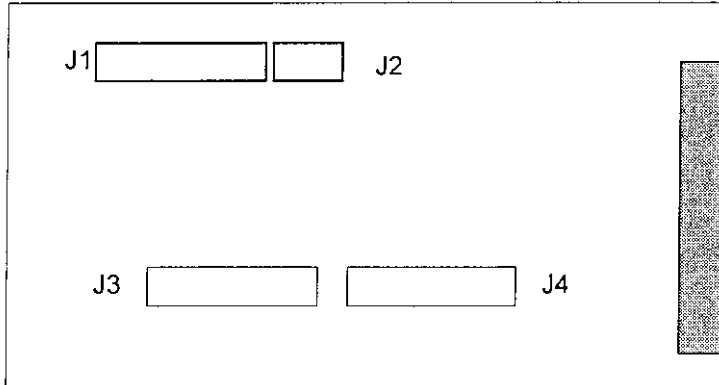

ASYNCHRONOUS

ISO2 /
WIFGAND

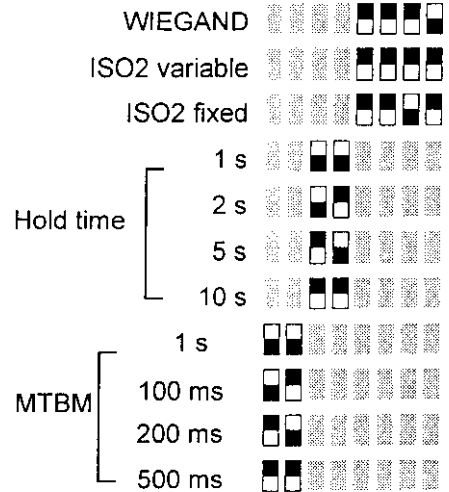
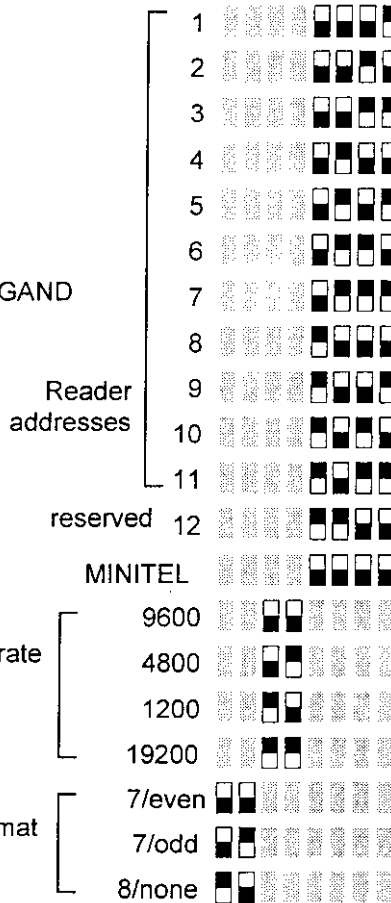
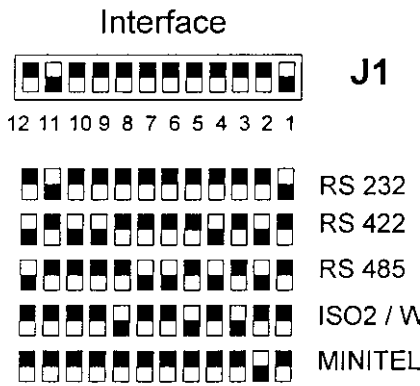

Note : Switch is OFF
 Switch is ON

CLASSIFICATION SOCIETE/ CLEARANCE LEVEL	REFERENCES DU DOCUMENT / DOCUMENT REFERENCES						PAGE
	Code Fabricant / Manufact. Code	Numéro / Number	Code Doc / Doc. Code	Tome / Volume	Indice / Revision Index	Langue Language	
NON PROTEGE	F0057	46 322 782	108			E	38

Mode



ISO2 /
WIEGAND

ASYNCHRONOUS

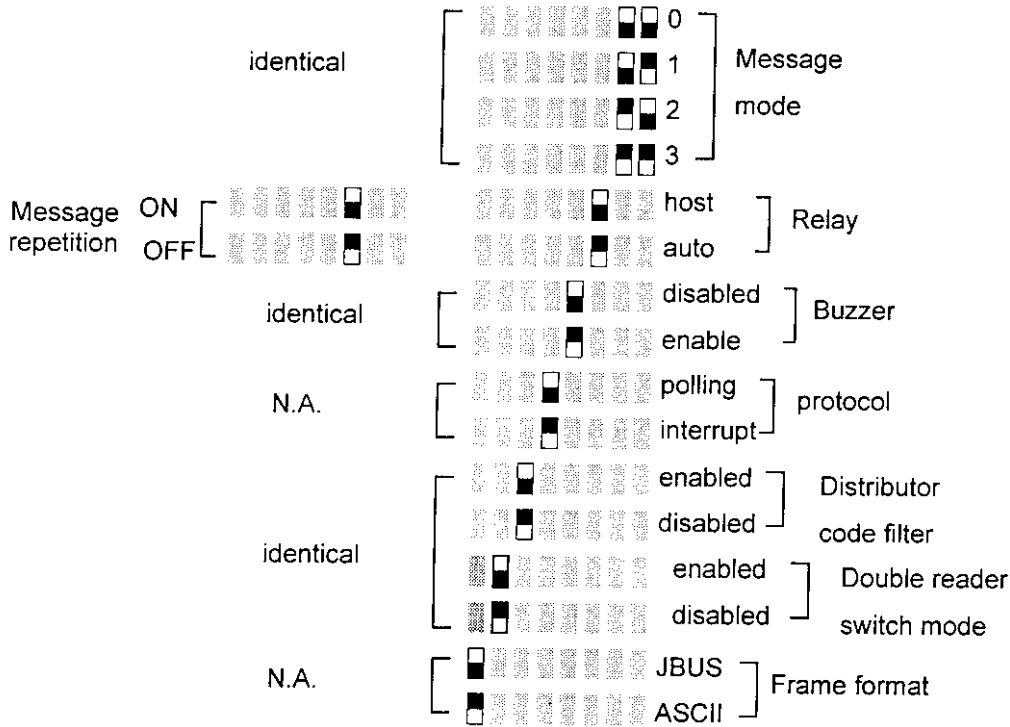

Note : Switch is OFF
 Switch is ON

CLASSIFICATION SOCIETE/ CLEARANCE LEVEL	REFERENCES DU DOCUMENT / DOCUMENT REFERENCES						PAGE
	Code Fabricant / Manufact. Code	Numéro / Number	Code Doc / Doc. Code	Tome / Volume	Indice / Revision Index	Langue Language	
NON PROTEGE	F0057	46 322 782	108			E	39

5. Annexe B : Special Modes (Test Mode And Minitel Mode)

Test Mode

This mode is configured using switch 8 of J3 (see 3.2.4)

The information transmitted from the reader to the host normally uses a JBUS frame format. During system installation, the host computer may not yet be connected or available. For this reason, an ASCII transmission mode exists, allowing the connection of a dumb terminal in order to visualise the messages sent and thus to verify correct system operation. This is called **test** mode and is enabled using a board jumper configuration

This mode has the following characteristics :

- interrupt mode is used (the tag-code is sent immediately)
- tag persistence = 1 second
- frame structure = 24H / status tag / 20H / code / 0DH / 0AH
- transmission characteristics (baud rate and character format) must be configured

Example:

During system installation, the reader is put into test mode. A terminal is connected to the reader via an RS-232 link. Transmission characteristics of reader and terminal are matched, and tags are held in front of antenna. The terminal will display messages of the type :

\$0 001ABCDEF-100
\$2 XYZHYPER X.007

The messages have the following structure :

\$ <status badge>(space) <distributor code> <user code>

where status badge : 0 = antenna 1, tag battery good
 1 = antenna 1, tag battery low
 2 = antenna 2, tag battery good
 3 = antenna 2, tag battery low

distributor code : nnn where n is a digit (0 à 9)

user code : from 1 to 30 characters

message	antenna	battery	distr. code	user code
0 001ABCDEF-100	1	good	001	ABCDEF-100
2 XYZHYPER X.007	2	good	XYZ	HYPER X.007

CLASSIFICATION SOCIETE/ CLEARANCE LEVEL	REFERENCES DU DOCUMENT / DOCUMENT REFERENCES						PAGE
	Code Fabricant / Manufact. Code	Numéro / Number	Code Doc / Doc. Code	Tome / Volume	Indice / Revision Index	Langue Language	
NON PROTEGE	F0057	46 322 782	108			E	40

Mode Mintel

This mode is configured using switches 1 to 4 of J4 (see §3.2.1)

This mode is similar to test mode, in that the messages sent have the same format (see above), yet it takes the specific nature of mintel operation into account. On a reader reset, special codes are sent which :

- clear the screen
- position the cursor in the upper left corner
- configure the mintel in scroll mode

Additionally, transmission characteristics are fixed independently of switches 5 to 8 of J4 : 1200 baud, 7 bits data, even parity. Only switches 1 to 4 of J4 need to be set.

This is a simplex link, reader to mintel, and needs switch 2 of J1 to be ON.

PAGE 41	CLASSIFICATION SOCIETE/ CLEARANCE LEVEL		REFERENCES DU DOCUMENT / DOCUMENT REFERENCES								
	NON	PROTEGE	Code Fabricant / Manufact. Code	F0057	Numéro / Number	46 322 782	Code Doc / Doc. Code	108	Tome / Volume	Index / Revision Index	E



THOMSON-CSF
COMMUNICATIONS

Département
Communications
Hyperfréquences

ORIGINE / ISSUED

Etablissement / Plant

Emetteur / By

TOULOUSE

DCH

INTERFACE MANUAL

FOR HYPERX READERS

Rédigé par / Written by : W. Löbert

Service / Department : Engineering

Signature / Sign :

Approuvé par / Approved by : P. Gobrecht

Service / Department : Product Manager

Signature / Sign :

Autorisé par / Authorized by :

Service / Department :

Signature / Sign :

Nom / Name :

Service / Department :

Signature / Sign :

Nom / Name :

Service / Department :

Signature / Sign :

Nom / Name :

Service / Department :

Signature / Sign :

Date de l'édition
Issue date : 02 Dec 1997

Archive :

Total
pages iv / 52

CLASSIFICATION SOCIETE/
CLEARANCE LEVEL

NON

REFERENCES DU DOCUMENT / DOCUMENT REFERENCES

Code Fabricant /
Manufact. Code

Numéro / Number

Code Doc /
Doc. Code

Tome /
Volume

Indice /
Revision Index

Langue
Language

PAGE

EVOLUTIONS SUCCESSIVES / SUCCESSIVE CHANGES

INDICE / REVISION INDEX	DATE	MODIFIE PAR / CHANGED BY	OBJET / DESCRIPTION
A	05 Nov 1997	W. Löbert	Création (fichier MAN_INT.DOC)
B	02 Dec 1997	W. Löbert	Corrections mineures, modif MTBM §3.1.4

Empty space reserved for document content or additional notes.

CLASSIFICATION SOCIETE/ CLEARANCE LEVEL	REFERENCES DU DOCUMENT / DOCUMENT REFERENCES						PAGE
	Code Fabricant / Manufact. Code	Numéro / Number	Code Doc / Doc. Code	Tome / Volume	Indice / Revision Index	Langue Language	
NON							ii

TABLE OF CONTENTS

1. GENERAL INFORMATION	5
1.1. DESCRIPTION OF THE HYPERX READERS	5
1.2. BASIC OPERATION.....	5
1.3. POWER SUPPLY.....	6
2. OVERVIEW.....	7
2.1. CONNECTORS	7
2.2. FRONT PANEL.....	7
2.3. ANTENNA INDICATOR LIGHT.....	9
3. CONFIGURING THE MODULAR READER.....	11
3.1. ISO2 AND WIEGAND INTERFACES	12
3.2. ASYNCHRONOUS SERIAL LINK.....	13
3.3. MESSAGE MODE.....	15
3.4. RELAY OPERATION.....	16
3.5. BUZZER OPERATION	16
3.6. CODE FILTERING WITH THE DISTRIBUTOR CODE	17
3.7. SWITCHING MODE FOR DOUBLE READER	17
3.8. ELECTRICAL INTERFACE	17
4. CONFIGURING THE COMPACT READER.....	18
4.1. ISO2 AND WIEGAND INTERFACES	18
4.2. ASYNCHRONOUS SERIAL LINK.....	19
4.3. MESSAGE MODE.....	21
4.4. RELAY OPERATION.....	21
4.5. BUZZER OPERATION	22
4.6. CODE FILTERING WITH THE DISTRIBUTOR CODE	22
4.7. ELECTRICAL INTERFACE	22
4.8. READING RANGE	22
4.9. OPERATING CHANNEL	22
5. OPEN-COLLECTOR INTERFACES.....	24
5.1. MAGNETIC STRIPE CARD INTERFACE «ISO2»	24
5.2. WIEGAND COMPATIBLE INTERFACE.....	26
6. COMMUNICATION PROTOCOL FOR ASYNCHRONOUS INTERFACE.....	28
6.1. INTRODUCTION.....	28
6.2. TRANSMISSION CHARACTERISTICS	29
6.3. READER IN POLLED MODE	29
6.4. READER COMMANDS	32
6.5. READER IN INTERRUPT MODE.....	39
7. EXTERNAL CONNECTIONS.....	40
7.1. 5-PIN CONNECTOR - LINK TO HOST	40
7.2. 3-PIN CONNECTOR - RELAYED CIRCUIT	40
7.3. INSTALLATION AND CONNECTION PROCEDURES FOR THE ASYNCHRONOUS LINKS	41
7.4. OUTPUT CIRCUIT FOR OPEN-COLLECTOR INTERFACE.....	43
8. APPENDIX A : JUMPER SETTINGS FOR MODULAR READER OLD VERSION.....	44
9. APPENDIX B : SWITCH SETTINGS FOR MODULAR READER NEW VERSION.....	46

CLASSIFICATION SOCIETE/ CLEARANCE LEVEL	REFERENCES DU DOCUMENT / DOCUMENT REFERENCES						PAGE
NON	Code Fabricant / Manufact. Code	Numéro / Number	Code Doc / Doc. Code	Tome / Volume	Indices / Revision Index	Langue Language	
							iii



10. APPENDIX C : SWITCH SETTINGS FOR COMPACT READER.....48

11. APPENDIX D : DESCRIPTION OF TEST MODE.....50

12. APPENDIX E : ALGORITHM FOR CALCULATING THE CRC1651

13. APPENDIX F : CHANNEL FREQUENCIES FOR COMPACT READER.....52

CLASSIFICATION SOCIETE/
CLEARANCE LEVEL

NON

REFERENCES DU DOCUMENT / DOCUMENT REFERENCES

Code Fabricant /
Manufact. Code

Numéro / Number

Code Doc /
Doc. Code

Tome /
Volume

Indice /
Revision Index

Langue
Language

PAGE

1. GENERAL INFORMATION

1.1. Description of the HYPERX readers

HYPERX™ is a multi-tag dynamic identification system using microwaves. A 'reader' emits microwaves up to a distance of one or more meters, depending on model. When a tag enters this zone, it modulates this radiation, thereby sending its code back to the reader, which then processes the received signal and extracts the code.

There are two types of readers, modular (different modules assembled in a rack) and compact. For the modular readers, SPI is the reader module which provides the host interface. SPI performs digital processing of the signal received from the microwave receiver module (SAM or LAM) and communication functions with a host. It plugs into a custom rack for single-Europe size boards, taking up a slot of width 6E. A custom backplane provides interconnection between the modules. The compact reader is a compact version of the basic modular reader in the form of a single box. It performs basically the same functions as the modular reader, with differences in performance (see the appropriate product specifications).

Basic functions performed are :

- tag detection
- relay 24V/1A for external circuit-switching (controlled via host),
- communication interfaces:
 - asynchronous serial link (RS 232, RS 422 or RS 485) using JBUS™ / MODBUS™ protocol (polled or interrupt)
 - or
 - compatible magnetic stripe card format "ISO-7811/2"
 - or
 - compatible WIEGAND tags

Certain functions described in this document are only relevant to recent firmware versions. Identify the version you are equipped with and make sure the desired function is supported.

1.2. Basic operation

Tags are encoded with a HYPERX™ programming device. They can contain a user code of up to 30 characters (digits, uppercase letters and some punctuation symbols). They also contain a 3-character distributor code.

When a tag is first detected, it is stored in an internal buffer and remains present for a time T_r . After this time, the tag is removed from memory. At first detection, a message for the host interface is generated and the relay is activated. In most cases (ISO2, Wiegand, asynch link interrupt mode) this message is immediately sent, in one case (asynch link polling mode) the message is only sent on request by the host. If a tag is detected by the reader and it is still in memory (two detections of same tag within the time T_r), a new message is not normally generated (exception is message mode 2, see chapter 3.3). The timer associated with this tag is then reset so that the tag remains present for a further time T_r . Thus, for a tag which is presented to the reader and remains there, only one message is generated after the initial detection. The tag must be removed for a time greater than T_r in order for a second message to be generated.

In the case of an asynchronous link to the host, the default value for T_r is 1 second, however this value can be changed via a JBUS command. In the case of an ISO2 or Wiegand interface, the value is determined by board jumper settings. The time T_r is hereafter referred to as the tag persistence time.

CLASSIFICATION SOCIETE/ CLEARANCE LEVEL	REFERENCES DU DOCUMENT / DOCUMENT REFERENCES						PAGE
	Code Fabricant / Manufact. Code	Numéro / Number	Code Doc / Doc. Code	Tome / Volume	Indice / Revision Index	Langue Language	
NON PROTEGE	F0057	46 322 790	104		B	E	5

2. OVERVIEW

2.1. Connectors

There are several PHOENIX - type connectors:

- The 5-pin connector is for the serial link to a host.
- The 3-pin connector allows switching (using the internal relay) of an external circuit
- For the compact reader only, a 2-pin connector is for the DC power supply

(See chapter 7 for the wiring instructions)

For the modular reader, the connectors are accessible on the front panel of the SPI module. For the compact reader, the connectors are accessible from the back at the top.

2.2. Front Panel

2.2.1. Modular reader

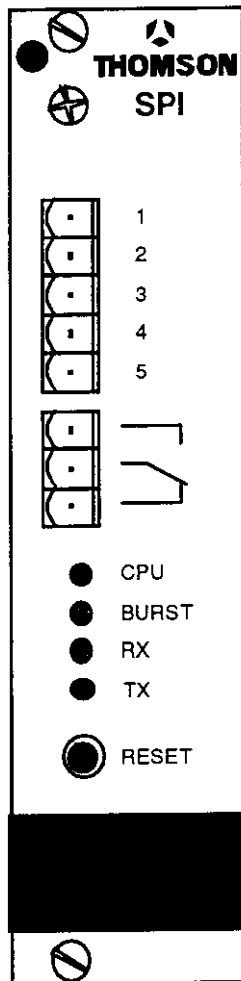

Figure 2-1: Front Panel of module SPI, comprising 2 Connecteurs, 4 leds and 1 Reset button

CLASSIFICATION SOCIETE/ CLEARANCE LEVEL	REFERENCES DU DOCUMENT / DOCUMENT REFERENCES						PAGE
	Code Fabricant / Manufact. Code	Numéro / Number	Code Doc / Doc. Code	Tome / Volume	Indice / Revision Index	Langue Language	
NON		12 822 700	104		P	E	7

2.2.2. Compact reader

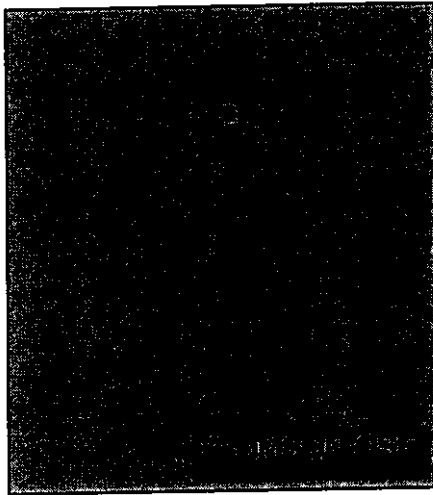

Figure 2-2 : Front panel of Compact reader

A single red/green light is situated in the top-centre of the panel (see chapter 2.3 below).

2.3. Antenna Indicator Light

The LED on the antenna (or in the case of the compact readers, on the front panel) indicates the state of the reader. It is under reader software control. It can also be controlled by the host using the JBUS protocol on an asynchronous serial link. The state diagram below shows the different possible states during power-up (or after a processor reset).

State Diagram :

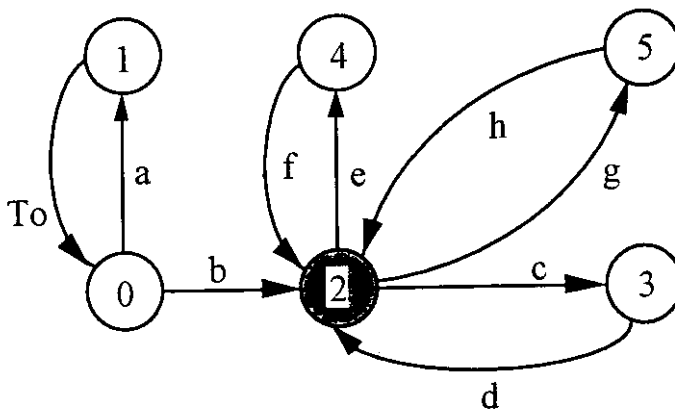

Events :

- a. internal hardware fault detected
- b. autotest OK
- c. module fault detected
- d. module fault disappears
- e. internal hardware fault detected
- f. internal hardware fault disappears
- g. received command "turn reader off"
- h. received command "turn reader on"

CLASSIFICATION SOCIETE/ CLEARANCE LEVEL	REFERENCES DU DOCUMENT / DOCUMENT REFERENCES						PAGE
	Code Fabricant / Manufact. Code	Numéro / Number	Code Doc / Doc. Code	Tome / Volume	Indice / Revision Index	Langue Language	
NON							

3. CONFIGURING THE MODULAR READER

There are two versions of the module currently available, for simplicity hereafter referred to as the **old** version and the **new** version. The old version consists of a mother board and a smaller daughter board using traditional through-hole technology. Configuring is done using jumpers. The new version consists of a single board using surface-mount technology. Configuring is done using miniature switches. In order to correctly configure the module, you must identify the version you are installing. In the following paragraphs, text in *italics* refers to the old version.

For old versions only - some jumpers do not change position :

- J1 - must be in position 2-3*
- J6 - must be present*
- J7 - must be absent*
- J13 - must be present in position 2-3*

These four jumpers no longer exist on the new version.

The different operating modes are selected using switches/*jumpers* which are either :

- ON (*present*) or
- OFF (*absent*)

They are identified by their positions on four connectors:

- J1 (8 positions 1 to 8) / J3 (10 positions 1 to 10)
- J2 (4 positions 9 to 12) / J8 (2 positions 11 to 12)
- J4 (8 positions 1 to 8) / J4 (8 positions 1 to 8)
- J3 (8 positions 1 to 8) / J5 (8 positions 9 to 16)

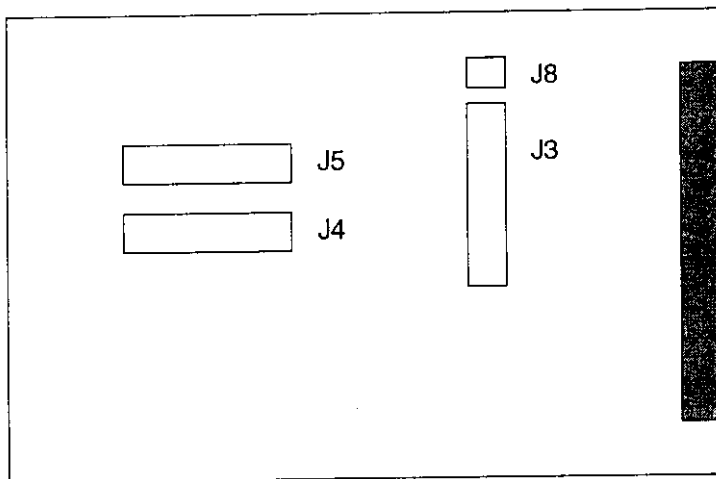

Figure 3-1 : Connector locations for SPI module - old board

CLASSIFICATION SOCIETE/ CLEARANCE LEVEL	REFERENCES DU DOCUMENT / DOCUMENT REFERENCES						PAGE
	Code Fabricant / Manufact. Code	Numéro / Number	Code Doc / Doc. Code	Tome / Volume	Indice / Revision Index	Langue Language	
NON	F0057	46 322 790	104		B	E	11



3.1.3. Tag persistence

Positions 5 and 6 of J4 must be as follows :

6	5	Persistence
ON	ON	1 s
ON	OFF	2 s
OFF	ON	5 s
OFF	OFF	10 s

3.1.4. Minimum Time Between Messages (MTBM)

Positions 7 and 8 of J4 must be as follows :

8	7	MTBM
ON	ON	1000 ms
ON	OFF	100 ms
OFF	ON	200 ms
OFF	OFF	500 ms

3.1.5. Tag message repetition

Position 3 of J3 / 11 of J4 must be as follows :

	repetition
OFF	disabled
ON	enabled

3.2. Asynchronous serial link

3.2.1. Address

The module's physical address is the logical slave address that the host application software uses to address the module (see 6.3).

CLASSIFICATION SOCIETE/ CLEARANCE LEVEL	REFERENCES DU DOCUMENT / DOCUMENT REFERENCES						PAGE
	Code Fabricant / Manufact. Code	Numéro / Number	Code Doc / Doc. Code	Tome / Volume	Indice / Revision Index	Langue Language	
NON PROTEGE	F0057	46 322 790	104		B	E	13



The four positions 1 to 4 of J4 determine the physical address:

4	3	2	1	Address
ON	ON	ON	ON	reserved use
ON	ON	ON	OFF	1
ON	ON	OFF	ON	2
ON	ON	OFF	OFF	3
ON	OFF	ON	ON	4
ON	OFF	ON	OFF	5
ON	OFF	OFF	ON	6
ON	OFF	OFF	OFF	7
OFF	ON	ON	ON	8
OFF	ON	ON	OFF	9
OFF	ON	OFF	ON	10
OFF	ON	OFF	OFF	11
OFF	OFF	ON	ON	12
OFF	OFF	ON	OFF	see 3.1.1 ISO2
OFF	OFF	OFF	ON	see 3.1.2 WIEGAND
OFF	OFF	OFF	OFF	see 3.1.1 ISO2

NB : A JBUS command message which has a slave address equal to 0 corresponds to a broadcast message, which explains why a reader cannot have an address of 0 for polling applications.

3.2.2. Character Format and Baud rate

-- Baud rate is chosen using positions 5 and 6 of J4:

6	5	Baud rate
ON	ON	9600 Bauds
ON	OFF	4800 Bauds
OFF	ON	1200 Bauds
OFF	OFF	19200 Bauds

Format is chosen using positions 7 and 8 of J4:

8	7	Format
ON	ON	7 bits data 1 bit even parity
ON	OFF	7 bits data 1 bit odd parity
OFF	ON	8 bits data no parity
OFF	OFF	not used

3.2.3. Protocol : polling or interrupt

The type of protocol, polled or by interrupt, is chosen with position 5 on J3 / 13 on J5 :

	protocol
OFF	interrupt
ON	polling

3.2.4. Frame format

Position 8 on J3 / 16 on J5 determines the frame format, test (ASCII) or JBUS (binary).

	frame format
OFF	Test - ASCII message
ON	Normal - JBUS frame

The test format allows connection to a dumb terminal for easy on-site display. For a description see chapter 11.

3.3. Message mode

The mode is chosen using positions 1 and 2 on J3 / 9 and 10 on J5. The mode determines in what cases the detection of a tag causes a message to be transmitted to the host.

Type 0 - Each time a tag is detected, a timer is armed (nominal value = 1s). Tag detection only causes a message to be transmitted if this timer is not active. Each tag detected has a timer associated with it.

Type 1 - This mode is no longer supported

Type 2 - At each tag detection, a message is transmitted to host. During message transmission, microwave emission is switched off. Only available for the ISO2 interface and the asynchronous start/stop interface in the interrupt mode.

Type 3 - When a tag "disappears" (is removed from internal memory), an extra message is transmitted to host which includes the tag's code as well as the number of times that the badge was detected. This number cannot be greater than 99. Not available for the Wiegand interface. Otherwise identical to type 0.

2 (10)	1 (9)	message mode
OFF	OFF	Type 3
OFF	ON	Type 2
ON	OFF	Type 1 - no longer supported
ON	ON	Type 0

PAGE 16	CLASSIFICATION SOCIÉTÉ/ CLEARANCE LEVEL		REFERENCES DU DOCUMENT / DOCUMENT REFERENCES					
	NON		Code Fabricant / Manufact. Code	Numéro / Number	Code Doc / Doc. Code	Tome / Volume	Indice / Revision Index	Langue
	PROTEGE		F0057	46 322 790	104	B	E	

-Les informations contenues dans ce document demeurent la propriété du groupe THOMSON - CSF et ne doivent pas être divulguées par l'utilisateur à des tiers sans l'accord écrit de Thomson-CSF Communications -

The switch / jumper in position 4 on J3 / 12 on J5 activates or deactivates the buzzer on tag detection. When enabled, the buzzer emits a short sound (duration 50 ms) each time a tag is read.

3.5. Buzzer operation

Deactivation	
OFF	automatic
ON	under host control

When a tag is detected, the relay operates. The switch / jumper in position 3 on J3 / 11 on J5 determines one of two modes of deactivation (for ISO2 and Wiegand, deactivation is automatic) :

- automatic relay deactivation after 2 second delay.
- relay deactivation controlled by host via JBUS

3.4. Relay operation

Figure 3-3 : Flow Graphs describing the three message transmission modes

- | | |
|----------------|--------------------------------|
| Events | a : tag is detected |
| b : | timeout anti read |
| e : | message is sent |
| Actions | 1 : arm anti read timer |
| 2 : | start message transmission |
| 3 : | turn off reader |
| 4 : | turn on reader |
| 6 : | send tag disappearance message |

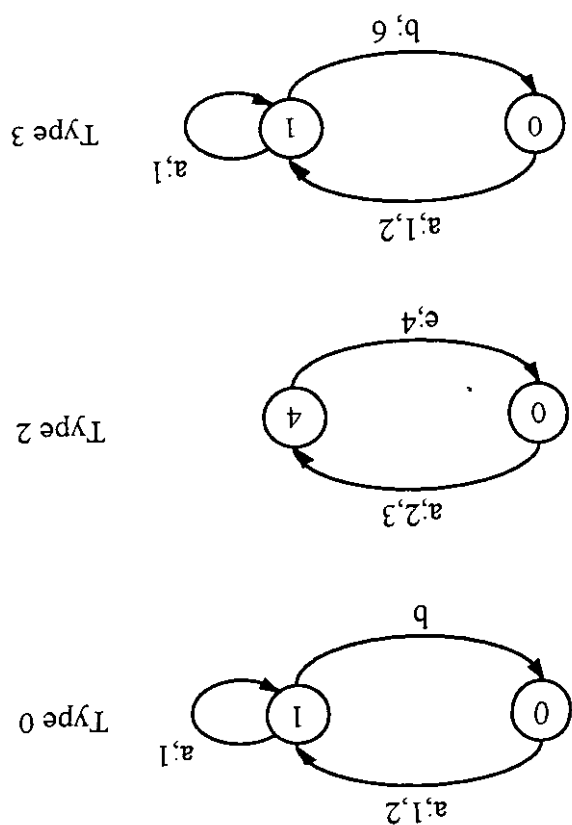



	Buzzer
OFF	Enabled
ON	Disabled

When enabled, the buzzer sounds for 50ms at every tag detection.

3.6. Code filtering with the Distributor code

The switch / *jumper* in position 6 on J3 / 14 on J5 enables or disables this feature. A description is given in chapter 5.2.3. Applies only to ISO2 and Asynchronous interfaces. For the WIEGAND interface this feature is automatically enabled.

	Filtering
OFF	Disabled
ON	Enabled

3.7. Switching mode for Double reader

The switch / *jumper* in position 7 on J3 / 15 on J5 enables or disables this feature. A description is given in chapter 1.2. This feature must be disabled for single readers.

	Switch mode
OFF	Disabled
ON	Enabled

3.8. Electrical Interface

The following positions on J1 and J2 / J3 and J8 determine the electrical interface to the host, by fixing which lines are physically routed through to the front-panel connector.

Type	Position
RS-232	1, 11
RS-422	2, 4, 9, 10, 12
RS-485	2, 4, 6, 7, 12
ISO2	3, 5, 8
WIEGAND	3, 5, 8

CLASSIFICATION SOCIETE/ CLEARANCE LEVEL	REFERENCES DU DOCUMENT / DOCUMENT REFERENCES						PAGE
	Code Fabricant / Manufacturer Code	Numéro / Number	Code Doc / Doc. Code	Tome / Volume	Indice / Revision Index	Langue Language	
NON							

4. CONFIGURING THE COMPACT READER

The different operating modes are selected using switches which are either :

- ON or
- OFF

They are identified by their positions on four connectors:

- J1 (12 positions 1 to 12)
- J2 (8 positions 1 to 8)
- J3 (8 positions 1 to 8)
- J4 (8 positions 1 to 8)

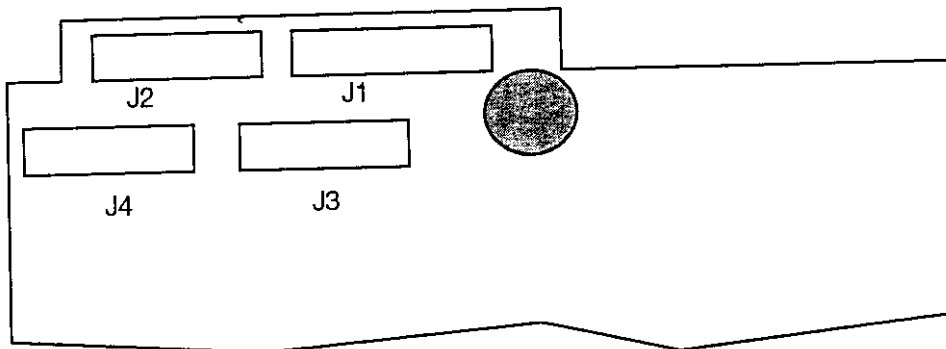

Figure 4-1 : Switch locations for configuration of Compact reader

The serial link to a host can be one of two types :

- Open-Collector (ISO2 or Wiegand)
- Asynchronous RS 232, RS 422 and RS 485.

NB: Only one of these interfaces can be active at a time

Certain switch combinations are forbidden. If these combinations are detected during the initialisation period (immediately following a reset), an internal reset is generated after a period of 4 seconds. The following combinations are forbidden :

- Message mode 3 together with WIEGAND interface
- Message mode 2 together with POLLING mode

4.1. ISO2 and WIEGAND Interfaces

4.1.1. ISO2 Interface

Positions 1 to 4 of J2 must be as follows :

4	3	2	1	message length
OFF	OFF	OFF	OFF	variable
OFF	OFF	ON	OFF	fixed

4.1.2. WIEGAND Interface

Positions 1 to 4 of J2 must be as follows :

4	3	2	1
OFF	OFF	OFF	ON

4.1.3. Tag persistence

Positions 5 and 6 of J2 must be as follows :

6	5	Persistence
ON	ON	1 s
ON	OFF	2 s
OFF	ON	5 s
OFF	OFF	10 s

4.1.4. Minimum Time Between Messages (MTBM)

Positions 7 and 8 of J2 must be as follows :

8	7	MTBM
ON	ON	1000 ms
ON	OFF	100 ms
OFF	ON	200 ms
OFF	OFF	500 ms

4.1.5. Tag message repetition

Position 3 of J3 must be as follows :

	repetition
OFF	disabled
ON	enabled

4.2. Asynchronous serial link

4.2.1. Address

The module's physical address is the logical slave address that the host application software uses to address the module (see 6.3).

The four positions 1 to 4 of J2 determine the physical address:

4	3	2	1	Address
ON	ON	ON	ON	MINITEL
ON	ON	ON	OFF	1
ON	ON	OFF	ON	2
ON	ON	OFF	OFF	3
ON	OFF	ON	ON	4
ON	OFF	ON	OFF	5
ON	OFF	OFF	ON	6
ON	OFF	OFF	OFF	7
OFF	ON	ON	ON	8
OFF	ON	ON	OFF	9
OFF	ON	OFF	ON	10
OFF	ON	OFF	OFF	11
OFF	OFF	ON	ON	12
OFF	OFF	ON	OFF	see 3.1.1 ISO2
OFF	OFF	OFF	ON	see 3.1.2 WIEGAND
OFF	OFF	OFF	OFF	see 3.1.1 ISO2

NB : A JBUS command message which has a slave address equal to 0 corresponds to a broadcast message, which explains why a reader cannot have an address of 0 for polling applications.

4.2.2. Character Format and Baud rate

Baud rate is chosen using positions 5 and 6 of J2:

6	5	Baud rate
ON	ON	9600 Bauds
ON	OFF	4800 Bauds
OFF	ON	1200 Bauds
OFF	OFF	19200 Bauds

Format is chosen using positions 7 and 8 of J2:

8	7	Format
ON	ON	7 bits data 1 bit even parity
ON	OFF	7 bits data 1 bit odd parity
OFF	ON	8 bits data no parity
OFF	OFF	not used

4.2.3. Protocol : polling or interrupt

The type of protocol, polled or by interrupt, is chosen with position 5 on J3:

	protocol
OFF	interrupt
ON	polling

4.2.4. Frame format

Position 8 on J3 determines the frame format, test (ASCII) or JBUS (binary).

	frame format
OFF	Test - ASCII message
ON	Normal - JBUS frame

The test format allows connection to a dumb terminal for easy on-site display. For a description see chapter 11.

4.3. Message mode

The mode is chosen using positions 1 and 2 on J3. The mode determines in what cases the detection of a tag causes a message to be transmitted to the host.

Type 0 - Each time a tag is detected, a timer is armed (nominal value = 1s). Tag detection only causes a message to be transmitted if this timer is not active. Each tag detected has a timer associated with it.

Type 1 - This mode is no longer supported

Type 2 - At each tag detection, a message is transmitted to host. During message transmission, microwave emission is switched off. Only available for the ISO2 interface and the asynchronous start/stop interface in the interrupt mode.

Type 3 - When a tag "disappears" (is removed from internal memory), an extra message is transmitted to host which includes the tag's code as well as the number of times that the badge was detected. This number cannot be greater than 99. Not available for the Wiegand interface. Otherwise identical to type 0.

2	1	message mode
OFF	OFF	Type 3
OFF	ON	Type 2
ON	OFF	Type 1 - no longer supported
ON	ON	Type 0

For a graphical representation of how the modes work, see Figure 3-3.

4.4. Relay operation

When a tag is detected, the relay operates. The switch in position 3 on J3 determines one of two modes of deactivation (for ISO2 and Wiegand, deactivation is automatic) :

- automatic relay deactivation after 2 second delay.
- relay deactivation controlled by host via JBUS

	Deactivation
OFF	automatic
ON	under host control

4.5. Buzzer operation

The jumper in position 4 on J3 activates or deactivates the buzzer on tag detection. When enabled, the buzzer emits a short sound (duration 50 ms) each time a tag is read.

	Buzzer
OFF	Enabled
ON	Disabled

4.6. Code filtering with the Distributor code

The switch in position 6 on J3 enables or disables this feature. A description is given in chapter 5.2.3. Applies only to ISO2 and Asynchronous interfaces. For the WIEGAND interface this feature is automatically enabled.

	Filtering
OFF	Disabled
ON	Enabled

4.7. Electrical Interface

The following positions on J1 and J2 determine the electrical interface to the host, by fixing which lines are physically routed through to the connector.

Type	Position
RS-232	1, 11
RS-422	2, 4, 9, 10, 12
RS-485	2, 4, 6, 7, 12
ISO2	3, 5, 8
WIEGAND	3, 5, 8

4.8. Reading Range

The reading range can be coarsely adjusted using switches 6 and 7 on J4. Three ranges are possible :

7	6	range
OFF	OFF	short
ON	OFF	short
OFF	ON	medium
ON	ON	long (normal)

4.9. Operating channel

The compact reader can operate using 29 different channels. Each channel corresponds to a separate microwave frequency band. This is useful when several readers must be positioned close together. Using different channels on each reader eliminates mutual interference. Positions 1 to 5 of J4 are used. The OFF position for switches are indicated by a blank in order to make the table more readable.

5	4	3	2	1	Channel
ON	ON	ON	ON		1
ON	ON	ON		ON	2
ON	ON	ON			3
ON	ON		ON	ON	4
ON	ON		ON		5
ON	ON			ON	6
ON	ON				7
ON		ON	ON	ON	8
ON		ON	ON		9
ON		ON		ON	10
ON		ON			11
ON			ON	ON	12
ON			ON		13
ON				ON	14
ON					15
	ON	ON	ON	ON	16
	ON	ON	ON		17
	ON	ON		ON	18
	ON	ON			19
	ON		ON	ON	20
	ON		ON		21
	ON			ON	22
	ON				23
		ON	ON	ON	24
		ON	ON		25
		ON		ON	26
		ON			27
			ON	ON	28
			ON		29

Table 4-1 : Microwave Channel selection

CLASSIFICATION SOCIETE/ CLEARANCE LEVEL	REFERENCES DU DOCUMENT / DOCUMENT REFERENCES						PAGE
	Code Fabricant / Manufact. Code	Numéro / Number	Code Doc / Doc. Code	Tome / Volume	Indice / Revision Index	Langue Language	
NON	50057	16 322 790	104		B	E	23

5. OPEN-COLLECTOR INTERFACES

5.1. Magnetic Stripe Card Interface «ISO2»

5.1.1. Description

Using this interface allows the reader to take the place of a standard magnetic stripe card reader. This interface consists of three signals, **MDATA** (negative logic) for the data, **STROBE** (active low) indicates when data are valid, and **PRES_BADGE** (active low) a signal encompassing message transmission as shown below. The characters are transmitted synchronously in a frame format at a rate of roughly 1000 bits/s.

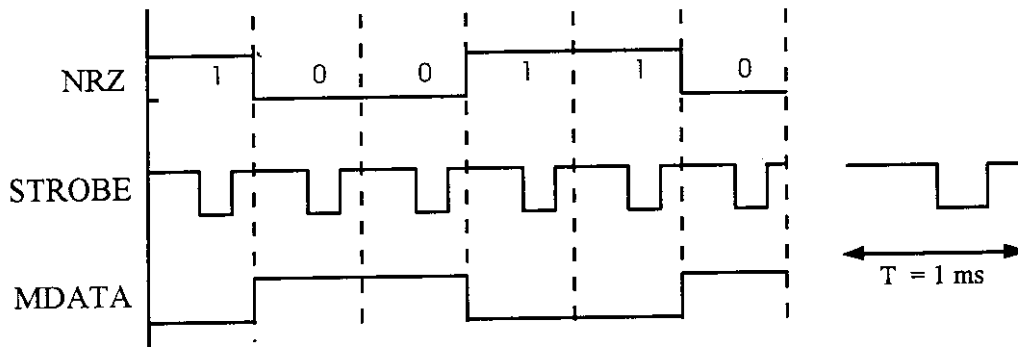

Figure 5-1: Signal timing for the ISO2 interface. Period for NRZ data is roughly 1 ms

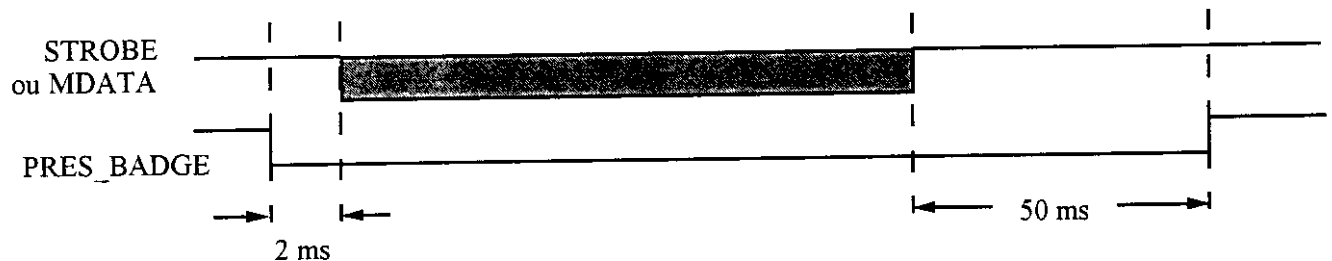

Figure 5-2 : Timing showing the signal "Presence Badge".

The STROBE and MDATA signals are open-collector outputs (circuit shown in Figure 7-3). For proper operation a pull-up resistor of about 1K ohm should be used.

5.1.2. Message format

A message consists of a preamble of 15 zeros (for receiver synchronisation), the data frame as described below, and a postamble of 10 zeros. The data (digits 0 to 9 only) are formatted into characters of 5 bits - 4 bits for a BCD coding plus one bit for odd parity. The data is framed as shown below.

1 Character	1 Character	1 Character
START	data	END LRC

The checksum (LRC) is the result of an exclusive-or function performed on all the preceding characters.

CLASSIFICATION SOCIETE/ CLEARANCE LEVEL	REFERENCES DU DOCUMENT / DOCUMENT REFERENCES						PAGE
	Code Fabricant / Manufact. Code	Numéro / Number	Code Doc / Doc. Code	Tome / Volume	Indice / Revision Index	Langue Language	
NON PROTEGE	F0057	46 322 790	104		B	E	24

START character = 0BH
END character = 1FH.

The contents of the data field depend upon the message mode chosen and the length. For a variable length frame, this field begins with a three-character distributor code, if no distributor-code filtering is enabled, followed by the user-code. For the fixed length frame, this field contains exactly 37 characters, the characters after the user-code, if there are less than 37, are all equal to 0DH.

In the case of message mode 3, the data also contains the number of times the tag was detected, a two-character field. The special separation character 0CH precedes this number.

The order of bit transmission for each character is LSB first.

Typical examples of the data field for a user code of length n digits :

message mode 0, length variable

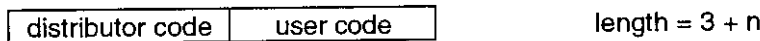

message mode 3, length variable

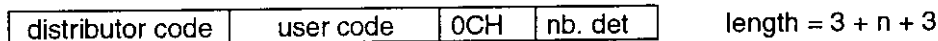

message mode 3, length variable, distributor-code filtering

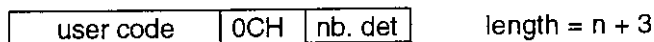

message mode 0, length fixed

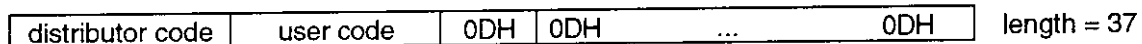

message mode 3, length fixed

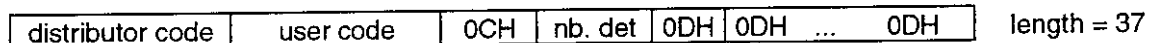

message mode 3, length fixed, distributor-code filtering

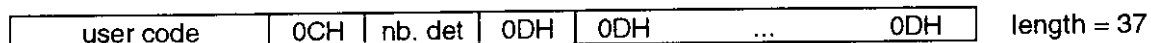

5.1.3. Tag persistence

The tag persistence (the time that a tag is stored in internal memory) can be set to one of four values using the board configuration (see 3.1.3) : 1 s, 2 s, 5 s and 10 seconds.

5.1.4. Tag code transmission

Two separate parameters can be set using the board configuration.

CLASSIFICATION SOCIETE/ CLEARANCE LEVEL	REFERENCES DU DOCUMENT / DOCUMENT REFERENCES						PAGE
NON	Code Fabricant / Manufact. Code	Numéro / Number	Code Doc / Doc. Code	Tome / Volume	Indice / Revision Index	Langue Language	
		10 000 700	101		P	E	25

The first is the minimum time between consecutive tag code transmissions (MTBM, see 3.1.4). This can be set to one of four values, 100 ms, 200 ms, 500 ms and 1 s, allowing interconnection to readers with different reaction times.

The second is the possibility of repeating the transmission of the tag code (see 3.1.5). This may be desirable in certain cases. If this option is enabled, the tag code is sent a second time after a time MTBM.

5.2. Wiegand compatible interface

5.2.1. Description

Using this interface allows the reader to take the place of a Wiegand-effect card reader. This interface comprises two signals, **DATA "0"** and **DATA "1"**. A logical 0 produces a negative pulse on the DATA_0 line and a logical one produces a negative pulse on the DATA_1 line. The timing is given in figure 5 below. The data is transmitted synchronously in a frame format at a rate of roughly 2000 bits/s

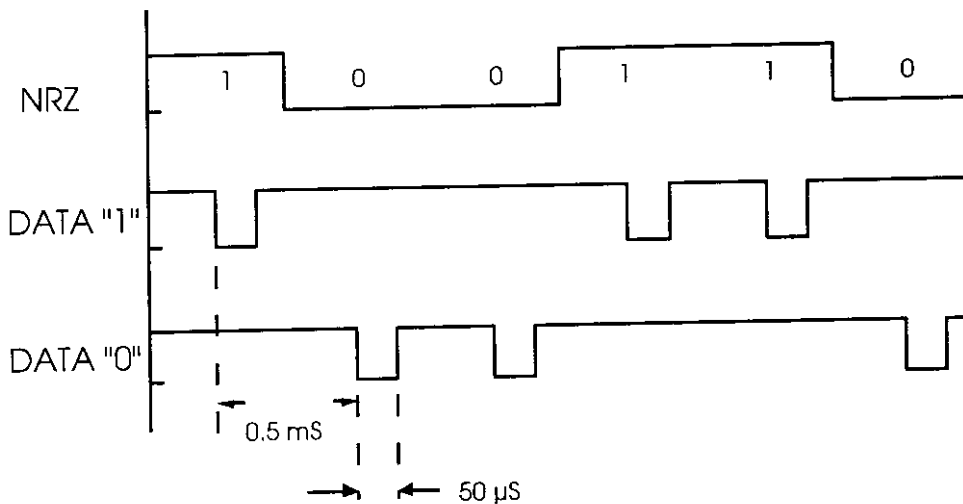
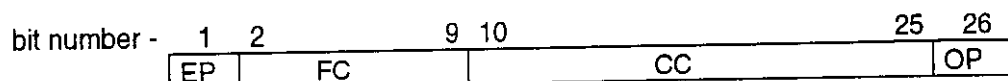

Figure 5-3 : Timing for WIEGAND Interface.

The DATA_0 and DATA_1 signals are open-collector outputs (circuit shown in Figure 7-3). For proper operation a pull-up resistor of about 1K ohm should be used.

5.2.2. Message format

The Wiegand message has a fixed length of 26 bits, and the following structure :



EP - Even parity bit

If the number of ones in the bits 2 to 13 is odd, then this bit is equal to 1, otherwise it is equal to 0.

FC - Facility Code

CLASSIFICATION SOCIETE/ CLEARANCE LEVEL	REFERENCES DU DOCUMENT / DOCUMENT REFERENCES						PAGE
	Code Fabricant / Manufact. Code	Numéro / Number	Code Doc / Doc. Code	Tome / Volume	Indice / Revision Index	Langue Language	
NON PROTEGE	F0057	46 322 790	104		B	E	26

length = 8 bits (bits 2 to 9)
A number, 0 to 255, binary-coded using 8 bits, MSB is bit 2.

CC - Card Code

length = 16 bits (bits 10 to 25)
A number, 0 to 65535, binary-coded using 16 bits, MSB is bit 10.

OP - Odd parity bit

If the number of ones in the bits 14 to 25 is even, then this bit is equal to 1, otherwise it is equal to 0.

Message transmission begins with bit 1.

5.2.3. Distributor code autq-learn mode

This facility is automatically enabled if the Wiegand interface is selected. However, it can also be enabled for the other interfaces if desired.

As well as the user data field, which for Wiegand corresponds to the 26 bit frame described above, the HYPERX tag contains a three character distributor code which is unique for each installation. This code is automatically added when the tag is first programmed.

The distributor code contained in the first tag which is detected after a processor reset becomes the reference distributor code. It is memorized, and the distributor codes of all succeeding tags are compared to this reference. If they are the same, the tag is allowed, if not the tag is rejected. In the former case, the message transmitted to the host does not contain this distributor code.

The distributor code consists of three ASCII digits, 0 - 9, allowing 1 000 combinations.

5.2.4. Tag persistence

The tag persistence (the time that a tag is stored in internal memory) can be set to one of four values using the board configuration (see 3.1.3) : 1 s, 2 s, 5 s and 10 seconds.

5.2.5. Tag code transmission

Two separate parameters can be set using the board configuration.

The first is the minimum time between consecutive tag code transmissions (MTBM, see 3.1.4). This can be set to one of four values, 100 ms, 200 ms, 500 ms and 1 s, allowing interconnection to readers with different reaction times.

The second is the possibility of repeating the transmission of the tag code (see 3.1.5). This may be desirable in certain cases. If this option is enabled, the tag code is sent a second time after a time MTBM.

CLASSIFICATION SOCIETE/ CLEARANCE LEVEL	REFERENCES DU DOCUMENT / DOCUMENT REFERENCES						PAGE
	Code Fabricant / Manufact. Code	Numéro / Number	Code Doc / Doc. Code	Tome / Volume	Indice / Revision Index	Langue Language	
NON PROTEGE	F0057	46 322 790	104		B	E	27

6. COMMUNICATION PROTOCOL FOR ASYNCHRONOUS INTERFACE

6.1. Introduction

Readers can be connected to a host using either a point-to-point configuration or a multipoint (bus) configuration. Furthermore, two types of protocol are possible : polling by host or interrupt.

The interrupt protocol uses either the JBUS™ frame format or the test mode format.

NB :

- (1) The interrupt protocol can only be used on a point to point link.
- (2) JBUS™ is registered by APRIL , MODBUS™ is registered by GOULD MODICON

A multipoint or network configuration using the standards for differential data transmission RS-485 (2-wire, 2-way) or RS-422 (4-wire, 2 for each way), is used if several readers are to be interconnected. In this case the polled JBUS protocol is implemented

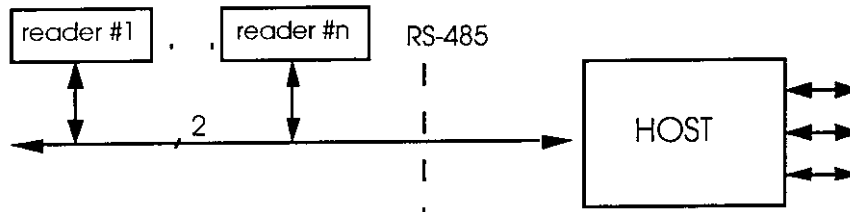

Figure 6-1 : Network topology using RS-485

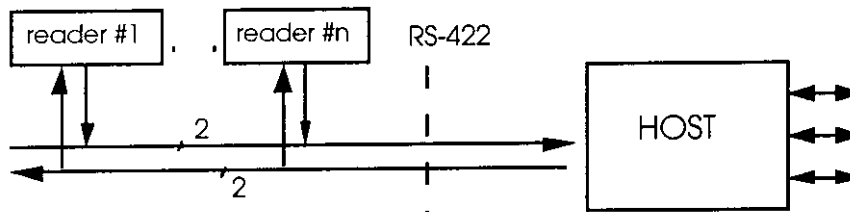

Figure 6-2 : Network topology using RS-422

If only one reader is to be connected, either of the three standards can be used. In this case either of the two protocols, polled (see chapter 6.3) or interrupt (see chapter 6.5), are possible.

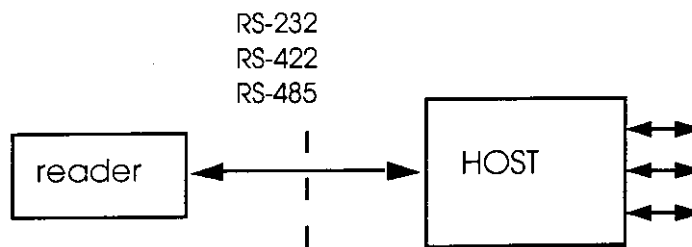

Figure 6-3 : Point-to-point topology

CLASSIFICATION SOCIETE/ CLEARANCE LEVEL	REFERENCES DU DOCUMENT / DOCUMENT REFERENCES						PAGE
	Code Fabricant / Manufact. Code	Numéro / Number	Code Doc / Doc. Code	Tome / Volume	Indice / Revision Index	Langue Language	
NON	50057	46 322 790	104		B	E	28

The table below summarizes the different combinations :

Protocol	Type of connection	
	point-to-point	multipoint
Interrupt	RS-232/422/485	—
Polling	RS-232/422/485	RS-422 or RS-485

6.2. Transmission characteristics

All protocols are character-oriented. The character formats are :

- 7 bits even parity / 1 stop bit
- 7 bits odd parity / 1 stop bit
- 8 bits no parity / 1 stop bit

Four baud-rates are possible :

- 1 200 bauds
- 4 800 bauds
- 9 600 bauds.
- 19 200 bauds

Choices are configured by user (see chapter 3.2.2).

NB : In practice, the JBUS protocol requires 8 bits / no parity. The other formats are used for special situations.

6.3. Reader in Polled Mode

This is a master/slave protocol. Each exchange is initiated by the master and consists, except in one case (broadcast message), an exchange of two frames - a command issued by the master and a reply from the slave. All frames have the following structure :

Slave no.	function code	data	control
-----------	---------------	------	---------

NB : A HYPER X reader is a JBUS™ slave.

The commands issued by the master are either addressed to one slave (identified by its number or address) or to all slaves on the network (broadcast).

The four fields have the following meanings :

- Slave number (1 byte) :
Specifies the destination, from 1 to 12. If the number is 0, it is a broadcast message. In this case there is no reply.
- function code (1 byte) :
Command : Determines the type of action to be performed (read, write, bit, word).
Reply : Result (success or error).
- data field (n bytes):
Contains the parameters associated with the function : command code, number of bytes, values.

CLASSIFICATION SOCIETE/ CLEARANCE LEVEL	REFERENCES DU DOCUMENT / DOCUMENT REFERENCES						PAGE
	Code Fabricant / Manufact. Code	Numéro / Number	Code Doc / Doc. Code	Tome / Volume	Indice / Revision Index	Langue Language	
NON	E0057	46 322 790	104		B	E	29



6.3.2. Write one word

- Command

		2 bytes		2 bytes		2 bytes
Address reader	06	command code	value*	CRC 16		

* A word consists of two bytes, msb first

- Reply

		2 bytes		2 bytes		2 bytes
Address reader	06	command code	value*	CRC 16		

The 'Reply' frame is identical to the 'Command' Frame.
If the address is 00H, all the readers process the command without sending a reply.

6.3.3. Write n words

- Command

		2 bytes		2 bytes		1 byte		n bytes		2 bytes
Address reader	10H	command code	nbr of words	nbr of characters	values *	CRC 16				

* words to be written, in order

- Reply

		2 bytes		2 bytes		2 bytes
Address reader	10H	command code	nbr of words	CRC 16		

If the address is 00H, all the readers process the command without sending a reply.

6.3.4. Read n words

- Command

		2 bytes		2 bytes
Address reader	03	command code	nbr of words	CRC 16

- Reply

		1 byte		n bytes
Address reader	03	nbr characters read [†]	values *	CRC 16

* bytes read, in order

† number of characters read = 2 X number of words in Command (always even)

CLASSIFICATION SOCIETE/ CLEARANCE LEVEL	REFERENCES DU DOCUMENT / DOCUMENT REFERENCES						PAGE
	NON	Code Fabricant / Manufact. Code	Numéro / Number	Code Doc / Doc. Code	Tome / Volume	Indice / Revision Index	
							31

6.4. Reader commands

The following commands can be sent to the reader by the host :

N°	Commands	function code	command code	command parameter	reply parameter
1	Get reader status	3	0040	nb words = 1	1 word status_l
2	Get modules status	3	0041	nb words = 1	1 word status_m
3	Get tag	3	0042	nb words = n	n words
4‡	Turn reader ON / OFF	6	0043	1 word emis	1 word emis
5	Relay control	5	0044	1 bit (0 =enable)	1 bit (0 =enable)
6	Reset reader	5	0045	1 bit (0 =reset)	1 bit (0 =reset)
7	Anti-reread time	6	0046	1 word time	1 word time
8	Antenna LED control	6	0047	1 word led	1 word led
9	Retransmit previous tag	3	0048	nb words = n	n words
10	Get init errors	3	004F	nb words = 1	1 word status_e
11*	Get EPROM version	3	0049	nb words = 1	1 word version (*)
12*	Get config	3	004A	nb words = 1	1 word config (*)
13†	Select channel	6	0050	1 word channel	1 word channel

Table 6-1 : Reader commands.

(*) Commands 11 and 12 are available as of EPROM version 4.00

(†) Command 13 is only available for the compact reader

(‡) Command 4 is only available for the modular reader

In order to read a tag (in polled mode), the host must first issue the command **get reader status**. The status word informs the host if a tag has been read, and if so, the length of the tag-code in bytes (see 6.4.3 below). In the latter case, the host then issues a second command **get tag**, indicating the number of words to be read.

NB : In interrupt mode, the command **get tag** is not used, since all tag-codes are sent immediately..

The words **status_l**, **status_m**, **status_e**, **led**, **emis**, **time**, **version**, **channel** and **config** are 16 bit words arranged as two bytes, msb first, lsb last.

6.4.1. Get reader status

This is a command of type **read n words**, code = 0040H. If the command parameter nb words is not equal to 1, the reader replies with the JBUS error 3 (Data incorrect).

The reader returns one word **status_l** (two bytes, MSbyte first).

status_l

D15												D8	D7						D0
BA	0	N5	N4	N3	N2	N1	N0	UC	AM	DP	MS	DM	E2	E1	RE				

bit	name	modular reader	compact reader
D15	BA	0 = 1 tag has been read, 1 = two or more tags have been read	
D13-D8	N5 .. N0	number of characters in tag (1 to 34), binary-coded in 6 bits	
D7	UC	User config, one or more parameters have been changed via a JBUS command (active 1)	
D6	AM	Fault in Power supply module	1
D5	DP	Tag memory overflow	
D4	MS	Fault with CPU	
D3	DM	Fault in one of the external modules	
D2	E2	Radio reception enabled for Antenna 2	1
D1	E1	Radio reception enabled for Antenna 1	
D0	RE	Relay activated	

- NB : When not specified, the bits are active low.

The length specified by the bits N5 ... N0 includes one byte for the tag's status, three for the distributor code and the rest for the user-code (see chapter 6.4.3). This number may be even or odd. However, when using the command **read n words** in order to read a tag-code, an even number of words must be specified and the reply always contains an even number of bytes, the last of which may not be significant.

If either of the bits AM or DM are active, the host should issue the command **read modules status** (chapter 6.4.2) in order to determine the cause. If the bit MS is active, the host should issue the command **read init errors** (chapter 6.4.10).

Example :

```

PC → reader  01 03 00 40 00 01 85 DE
reader → PC  01 03 02 00 7D 78 65
    
```

6.4.2. Get modules status

This is a command of type **read n words**, code = 0041H. If the command parameter nb words is not equal to 1, the reader replies with the JBUS error 3 (Data incorrect).

The reader returns one word **status_m** (two bytes, MSbyte first).

status_m

bit	name	modular reader	compact reader
D15	DCH	Battery-charger fault	1
D14	DAC	Mains fault	1
D13	DDC	Battery backup fault	1
D12	DTE	External DC input voltage fault	1
D11	PSHF2	Microwave source module HF2 present	1
D10	PSHF1	Microwave source module HF1 present	0
D9	PCMR2	Module SAM2 present	1
D8	PCMR1	Module SAM1 present	0
D7	unused	1	1
D6	unused	1	1
D5	ERV2	Phase-lock error source HF 2	1
D4	ERV1	Phase-lock error source HF 1	1
D3	ERS2	Fault in module HF 2	1
D2	ERS1	Fault in module HF 1	1
D1	PEM2	Microwave power present on SAM2	1
D0	PEM1	Microwave power present on SAM1	

- NB : All bits are active low.

Example :

```
PC -> reader  01 03 00 41 00 01 D4 1E
reader -> PC  01 03 02 FA FE 7B 64
```

6.4.3. Get tag

This is a command of type **read n words**, code = 0042H. If the number of words to be read (see 6.4.1) is different from the number of words available (see command **get reader status**), the reader replies with the JBUS error 8 (execution failure). This error is also produced if no tags are present.

The data field structure of the 'reply' frame is as follows :

1 byte	3 bytes	1 to 30 bytes
status_tag	distributor_code	user_code

The length of this field can vary from a minimum of 5 to a maximum of 34. The distributor code may not be present if distributor-code filtering is enabled.

Only two bits of **status_tag** are used :

D0 : tag battery (0 = OK, 1 = low)
D1 : Antenna number (0 = antenna 1 / SAM1, 1 = antenna 2 / SAM2) - for modular reader only
D4, D5 : 1
D6, D7 : 0

For modular readers :

- Antenna 1 is connected to the receiver module SAM1 (immediately to left of SPI in rack)
- Antenna 2 is connected to the receiver module SAM2 (leftmost SAM in a double rack).

The user-code can vary in length from 1 to 30 characters. It consists of any ASCII characters whose ASCII codes lie between 20H and 5FH.

Example :

```
PC -> reader  01 03 00 42 00 04 E4 1D
reader -> PC  01 03 08 30 31 32 33 39 39 39 39 B8 C5
```

6.4.4. Turning reader ON / OFF

This command is only available for the modular reader.

This command turns the microwave emission on or off. This is a command of type **write one word**, code = 0043H. One word (two bytes) must be sent, the most significant byte first.

emis

D15													D8 D7	D0	
NA	x	x	x	x	x	x	x	x	x	x	x	x	x	x	VE

NA : N°. antenna (0 = antenna 1, 1 = antenna 2)
VE : Enable emission (0 = enable, 1 = disable)

If this command is successfully executed by the reader, then the UC bit in the status word **status_I** is set to 1.

CLASSIFICATION SOCIETE/ CLEARANCE LEVEL	REFERENCES DU DOCUMENT / DOCUMENT REFERENCES						PAGE
NON	Code Fabricant / Manufact. Code	Numéro / Number	Code Doc / Doc. Code	Tome / Volume	Indice / Revision Index	Langue Language	
	50057	46 222 700	104		B	E	
							34

Example :

```
PC → reader  01 06 00 43 00 01 B9 DE
reader → PC  01 06 00 43 00 01 B9 DE
```

6.4.5. Relay control

This is a command of type **write one bit**, code = 0044H. If the parameter byte contains 0 the relay is energised, if it contains FFH, the relay is de-energised.

If this command is successfully executed by the reader, then the UC bit in the status word **status_1** is set to 1.

Example :

```
PC → reader  01 05 00 44 00 00 8D DF      (energise relay)
reader → PC  01 05 00 44 00 00 8D DF
```

6.4.6. Reset reader

This is a command of type **write one bit**, code = 0045H. If the parameter byte contains 0, an internal processor reset is generated. Any other value produces the JBUS error 3 (data incorrect).

This command resets all user configurable parameters to their default values and resets the UC bit in the status word **status_1** to 0 :

Parameter	Default value
Antenna light	green, slow blink
Anti reread time	1 second
Relay	de-energised
Microwave emission	ON

Example :

```
PC → reader  01 05 00 45 00 00 DC 1F      (reset)
reader → PC  01 05 00 45 00 00 DC 1F
```

6.4.7. Tag Persistence

This is a command of type **write one word**, code = 0046H. One word (two bytes) must be sent, the most significant byte first.

This time is expressed as a multiple of 50ms and binary-coded using 11 bits, giving a range from 50ms to 100 seconds.

time

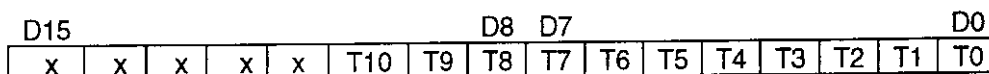

If a value of 0 is programmed, then the reader will send the tag-code at each detection. This is incompatible with several reader configurations and must be used with caution.

If this command is successfully executed by the reader, then the UC bit in the status word **status_1** is set to 1.

CLASSIFICATION SOCIETE/ CLEARANCE LEVEL	REFERENCES DU DOCUMENT / DOCUMENT REFERENCES						PAGE
	Code Fabricant / Manufact. Code	Numéro / Number	Code Doc / Doc. Code	Tome / Volume	Indice / Revision Index	Langue Language	
NON	50057	46 322 790	104		B	E	35

Example :

```

PC → reader  01 06 00 46 00 28 68 01      (time = 2s)
reader → PC  01 06 00 46 00 28 68 01
    
```

6.4.8. Antenna LED control

This is a command of type **write one word**, code = 0047H. One word (two bytes) must be sent, the most significant byte first.

led

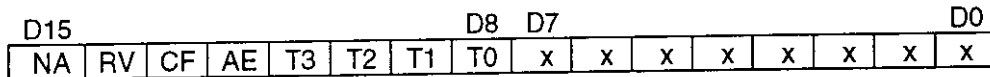

NA : N° antenna (0 = antenna 1, 1 = antenna 2) (=0 for compact reader)
 RV : 0 = LED red, 1 = LED green
 CF : 0 = blink, 1 = fixed
 AE : 0 = on, 1 = off
 T3 .. T0 : Blink period (on or off-time) as multiple of 50ms binary-coded using 4 bits. Thus :
 0001 : 50ms / 50 ms
 0010 : 100ms / 100 ms
 0011 : 150ms / 150 ms
 1111 : 750ms / 750 ms

If this command is successfully executed by the reader, then the UC bit in the status word **status_1** is set to 1.

Example :

```

PC → reader  01 06 00 47 05 00 3A 8F      (led ant 1 blinks red 250/250ms)
reader → PC  01 06 00 47 05 00 3A 8F
    
```

6.4.9. Retransmit previous tag

This is a command of type **read n words**, code = 0048H. If the number of words to be read (chapter 6.4.1) is different from the number of words available, the reader replies with the JBUS error 8 (execution failure). This error is also produced if no tags are present.

This command makes the reader retransmit the previous tag code, providing no other transmission has occurred since. It is used in polling mode if the reader's reply contains errors and the host wishes a retransmission. In such a case, repeating the command **read tag** is of no use, this command must be used. The number of words to be read must be the same as that used in the previous **read tag** command.

Example :

```

PC → reader  01 03 00 42 00 03 A5 DF      (read 3 words)

reader → PC  01 03 06 01 02 03 04 05 16 9B B3      (CRC incorrect)

PC → reader  01 03 00 48 00 03 85 DD      (retransmit 3 words)

reader → PC  01 03 06 01 02 03 04 05 06 9B B3      (CRC OK)
    
```

6.4.10. Get Init Errors

This is a command of type **read n words**, code = 004FH. If the command parameter nb words is not equal to 1, the reader replies with the JBUS error 3 (Data incorrect).

The reader returns one word **status_e** (two bytes, MSbyte first).

After a manual reset, the reader performs an internal test of its major hardware elements. If an error is detected, the **MS** bit in the reader status word is set (see 6.4.1) and the reader resets itself after 4 seconds and continues to do so until the fault disappears. This command, if sent after the end of the test (the buzzer sounds while the test is in progress), will determine the nature of the fault. One word **status_e** is to be read:

Only the 5 bits D0 to D4 are used :

status_e

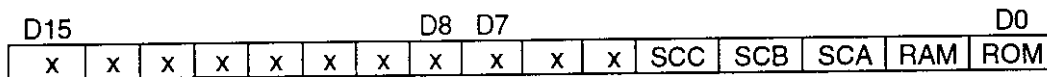

- ROM : EPROM checksum is incorrect
- RAM : RAM failure
- SCA : SCC channel A failure
- SCB : SCC channel B failure
- SCC : SCC bus access failure

The bits are active at 1.

Example :

PC → reader	01	03	00	4F	00	01	B5	DD	
reader → PC	01	03	02	00	00	B8	44		(no errors)

6.4.11. Get EPROM version

This is a command of type **read n words**, code = 0049H. If the command parameter nb words is not equal to 1, the reader replies with the JBUS error 3 (Data incorrect).

The reader returns one word **version** (two bytes, MSbyte first).

version

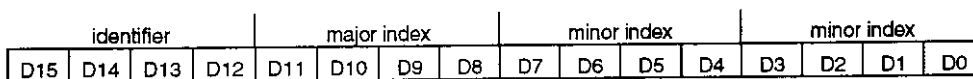

For the modular reader, the identifier has a fixed value equal to 0. For the compact reader, this value is equal to 5.

Thus, version = 0401H indicates a modular reader with EPROM version 4.01.
Version = 5403H indicates a compact reader with EPROM version 4.03.



6.5. Reader in Interrupt Mode

In this mode, as soon as a reader has a message to send to the host (i.e. a tag that has been detected), it sends it, rather than waiting for an invitation, as is the case in the polled mode. The host replies with an ACK or a NAK. The message sent has the following structure :

		1 byte		n bytes	
STX	04	nb characters		values	CRC 16

This structure is the same as that of a 'reply' frame to the command **read n words**. The first field, the reader number, is fixed at 2 and the second field, the code function, is fixed at 4.

Example :

			11 bytes											
02	04	0B	30	41	42	43	33	34	35	36	37	38	39	CRC 16

Here, the badge status = '0', the code read is 'ABC3456789'

The data field contains 11 bytes.

See chapter 6.4.3 for details of the structure of the data field.

The same message is retransmitted up to three times in case an ACK is not received. If a NAK is received the message is sent again immediately, if no reply is received the message is sent after a 100ms timeout. After three failed attempts, transmission for that message is abandoned.

This protocol is enabled using reader configuration (See chapter 3.2.3.).

NB :

In this mode of operation, the host can send all of the normal commands using the JBUS protocol (as defined in chapter 6.4 above), except for the one command **read tag** which would make no sense. The reader sends a reply just as if it were in polled mode. However, the reader cannot send a reply straight away if it has just detected a tag and has started to send this message, and vice versa. The host must decide if and when it can safely interrogate the reader.

CLASSIFICATION SOCIETE/ CLEARANCE LEVEL	REFERENCES DU DOCUMENT / DOCUMENT REFERENCES						PAGE
	Code Fabricant / Manufact. Code	Numéro / Number	Code Doc / Doc. Code	Tome / Volume	Indice / Revision Index	Langue Language	
NON							
PROTEGE	F0057	46 322 790	104		B	E	39

**7. EXTERNAL CONNECTIONS**

7.1. 5-pin Connector - link to Host

pin	Name	I/O
O1	O1	I/O
O2	O2	I/O
O3	O3	I/O
O4	O4	I
O5	GND	

Pins O1 to O4 are associated with different signals, depending on the type of link used (Board configuration: see chapter 3.8).

Name	RS-232	RS-422	RS-485	ISO2	WIEGAND
O1	TX	TX+	+ V	STROBE	DATA "1"
O2	—	TX-	- V	MDATA	DATA "0"
O3	—	RX+	—	PRES_BADGE	—
O4	RX	RX-	—	—	—
O5	GND	GND	GND	GND	GND

Signals on front panel 5-pin connector

Connector reference :

Brand :	PHOENIX	WAGO
5 pin	MSTB 2,5/5-ST-5,08	231-305/026-000

7.2. 3-pin Connector - relayed circuit

pin	Name	I/O
1	Make	O
2	Common	I
3	Break	O

Signals on front panel 3-pin connector

This connection allows a signal to be switched using the on-board relay. When the relay is not energized, pins 2 and 3 are connected together, when it is, pins 1 and 2 are connected together.

Connector reference :

Brand :	PHOENIX	WAGO
3 pin	MSTB 2,5/3-ST-5,08	231-303/026-000

CLASSIFICATION SOCIETE/ CLEARANCE LEVEL	REFERENCES DU DOCUMENT / DOCUMENT REFERENCES						PAGE
	Code Fabricant / Manufact. Code	Numéro / Number	Code Doc / Doc. Code	Tome / Volume	Indice / Revision Index	Langue Language	
NON PROTEGE	F0057	46 322 790	104		B	E	40

7.3. Installation and connection procedures for the asynchronous links

7.3.1. Electrical specifications

• Interface RS-232 :

Input (RX)	Input voltage range - 30V min, + 30V max V _{IL} threshold 1,2V typ V _{IH} threshold 1,7V typ	Output (TX)	Output voltage ± 5V min, ± 9V typ
------------	---	-------------	--------------------------------------

• Interface RS-422 :

Input (RX)	Common-mode voltage ± 7V max ± 12V max V _{IH} threshold 2V min V _{IL} threshold 0,8V max	Output (TX)	$V_{OH}(I_{OL} = -20mA)$ $V_{OH}(I_{OL} = 0)$ $V_{OL}(I_{OL} = 48mA)$ $V_{OL}(I_{OL} = 0)$ Differential voltage V_{OD1} ($I_O = 0$) Differential voltage ($R_L = 100\Omega$) Common-mode voltage ($R_L = 100\Omega$) $2,5V$ min $5V$ $0,5V$ max $0V$ $2V$ min, $5V$ max $0,5V_{OD1}$ ($2V$ min) $\pm 3V$ max
------------	--	-------------	--

• Interface RS-485 : identical to RS-422

7.3.2. Cables for RS-422 and RS-485

- Clean environments - twisted pairs, without screen.
- Noisy environments - twisted pairs, individual screen for each pair

Each cable is characterised by :

- its characteristic impedance (Z_0 in ohms)
- its distributed capacity (C_L in pF/m).
- its distributed resistance (R_L in ohms/m)

For short cable lengths, normal cables are satisfactory.

For cable lengths greater than 100 metres, high quality cables (low C_L and R_L) should be used for all baud rates.

7.3.3. Line Termination

For a simplex link, the termination (if present) should be placed at the receiving end of the line.

For a duplex link, the termination (if present) should be placed at the each end of the line.

CLASSIFICATION SOCIETE/ CLEARANCE LEVEL	PROTEGE					
	NON					
REFERENCES DU DOCUMENT / DOCUMENT REFERENCES	Code Fabricant / Manfact. Code	Numéro / Number	Code Doc / Doc. Code	Tome / Volume	Index / Revision Index	Langue
	F0057	46 322 790	104		B	E
PAGE	41					

For baud rates less than 1200 bauds, no termination is necessary. For baud rates greater than 9600 bauds and line lengths greater than 1000 metres, a resistor equal to the line impedance (120 ohms) is usually necessary. For cases in-between, there is no clear-cut rule and depends on individual installations (combination of baud-rate, line-length, cable quality, emitter/receiver characteristics).

7.3.4. Electrical connections

For an RS-232 link, wiring up is straightforward, the TX and RX lines of both equipments are connected together.

For a differential link (RS-422 or RS-485), the polarities are not always clearly defined. Normally the "+" line is at a high level at rest and is active low. For the "-" line, the opposite is true. This is the case for the differential interface for the HYPERX readers. However if the differential signals are generated by a converter acting on RS-232 signals, then the "+" line can be at a low level at rest and active high. In this case, the "+" line of one equipment must be connected to the "-" line of the other equipment.

Connection of 0V

Whether this is necessary or not, depends on the installation. If host and reader are distant with different local ground potentials, then an RS-232 link may not work if the 0V references are not connected. However connecting them will cause ground currents to circulate. In general, for large link lengths, a differential link should be used. This also tolerates a large common-mode voltage difference.

7.3.5. Networking

7.3.5.1. Topologies

The preferred topology is the bus.

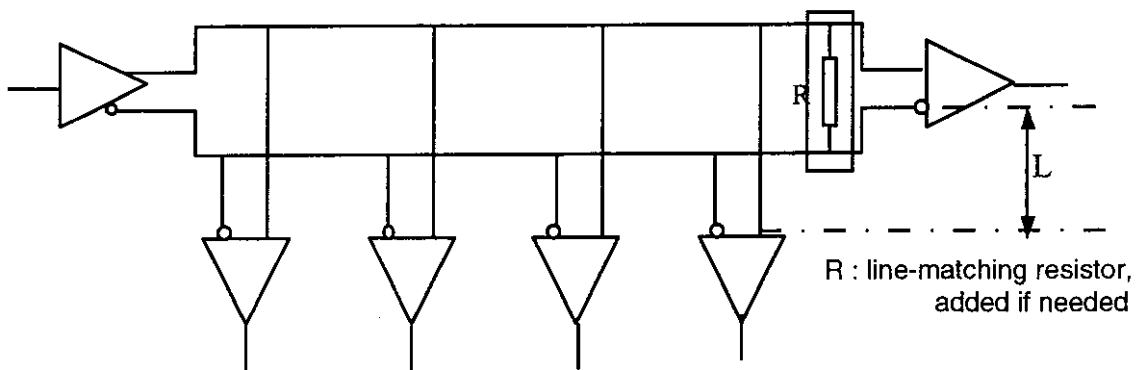

Figure 7-1 : Simplex link

CLASSIFICATION SOCIETE/ CLEARANCE LEVEL	REFERENCES DU DOCUMENT / DOCUMENT REFERENCES						PAGE
	Code Fabricant / Manufact. Code	Numéro / Number	Code Doc / Doc. Code	Tome / Volume	Indice / Revision Index	Langue Language	
NON	50057	46 200 700	104		P	E	42

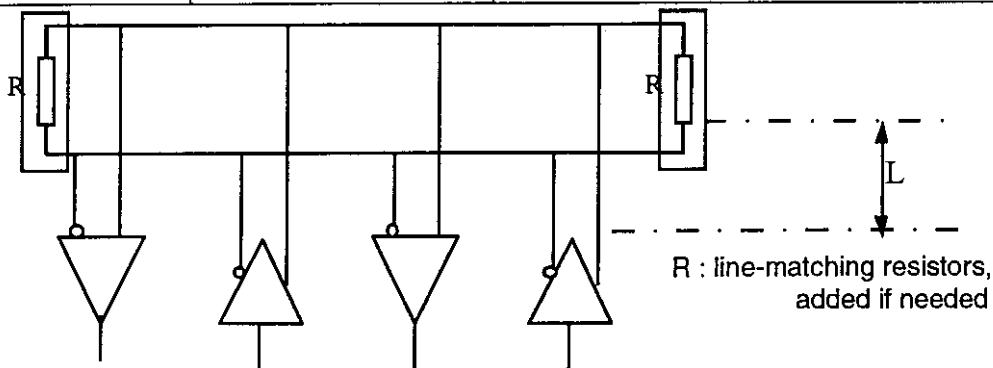

Figure 7-2 : Half duplex link

The length of the derivation should be as short as possible (< 30 cm).
The maximum length allowed can be calculated from the cable characteristics using the equation below.

$$L < 1300 / (Z_0 \times C_L) \quad L \text{ in metres, } Z_0 \text{ in ohms and } C_L \text{ in pF/m}$$

7.3.5.2. Line biasing

For RS-422 and RS-485, line biasing may prove necessary and must be done externally and only at one point on the line.

- The line "+" is connected to +5V via a 4K7 resistor.
- The line "-" is connected to 0V via a 4K7 resistor.

7.4. Output circuit for Open-collector interface

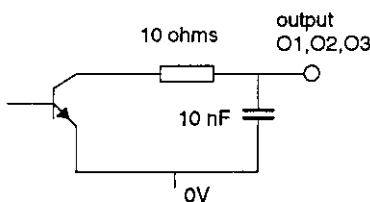
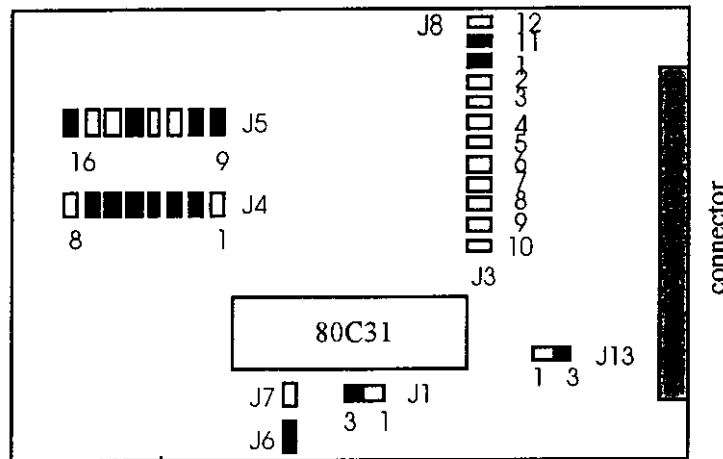

Figure 7-3 : Open-collector interface output circuit

CLASSIFICATION SOCIETE/ CLEARANCE LEVEL	REFERENCES DU DOCUMENT / DOCUMENT REFERENCES						PAGE
	Code Fabricant / Manufact. Code	Numéro / Number	Code Doc / Doc. Code	Tome / Volume	Indice / Revision Index	Langue Language	
NON							40

8. APPENDIX A : JUMPER SETTINGS FOR MODULAR READER OLD VERSION

Asynchronous serial interface



Fixed jumpers :

- J1 - position 2-3
- J6 - present
- J13 - position 2-3
- J7 - absent

Configuration shown :

RS-232, polling
 9600 bauds, 8 bits
 address = 1
 relay = auto
 buzzer = active
 serial mode = 0

Configuring the operating mode :

Connectors J4 (8 positions) and J5 (8 positions)

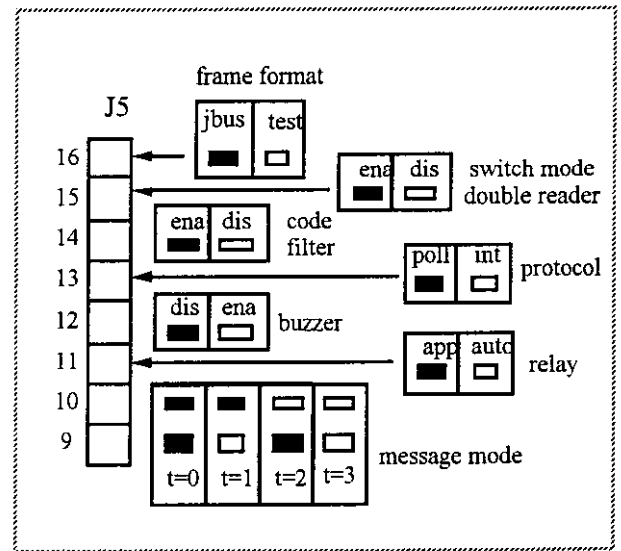
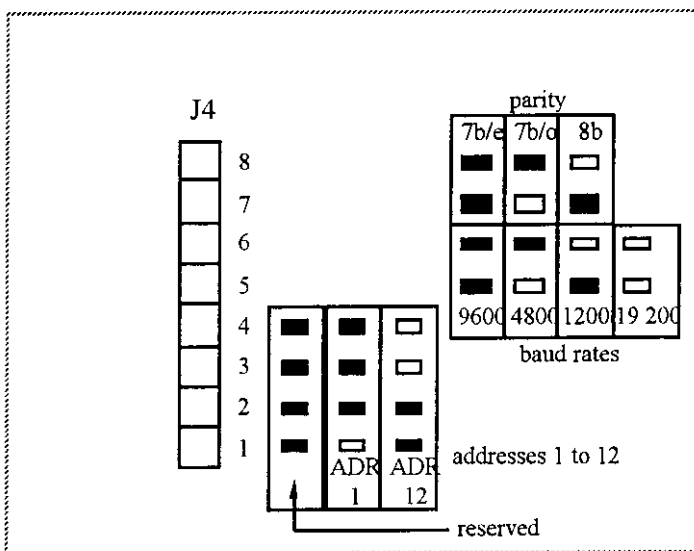

Configuring the electrical interface :

Jumpers for connectors J3 (10 positions, 1 to 10) and J8 (2 positions, 11 and 12) must be positioned as indicated below :

interface	positions J3	positions J8
RS-232	1	11
RS-422	2, 4, 9, 10	12
RS-485	2, 4, 6, 7	12

Modular reader old version - ISO2 and WIEGAND interfaces

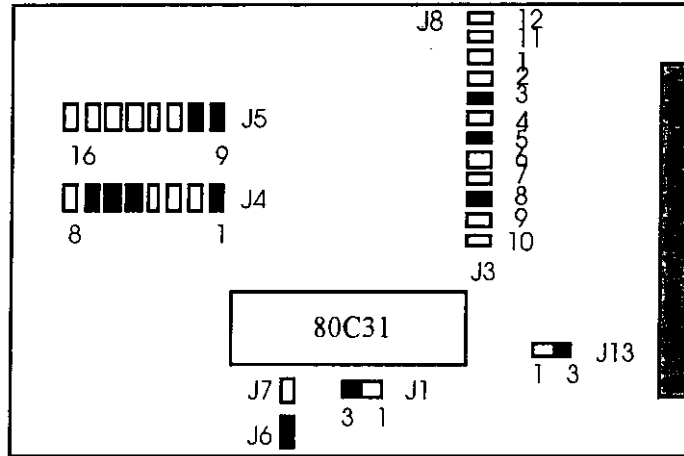

Fixed jumpers :

- J1 - position 2-3
- J6 - present
- J13 - position 2-3
- J7 - absent

Configuration shown :

Wiegand
Persistence = 1s
MTBM = 0.2s
buzzer = active

Configuring the operating mode :

Connectors J4 (8 positions) and J5 (8 positions)

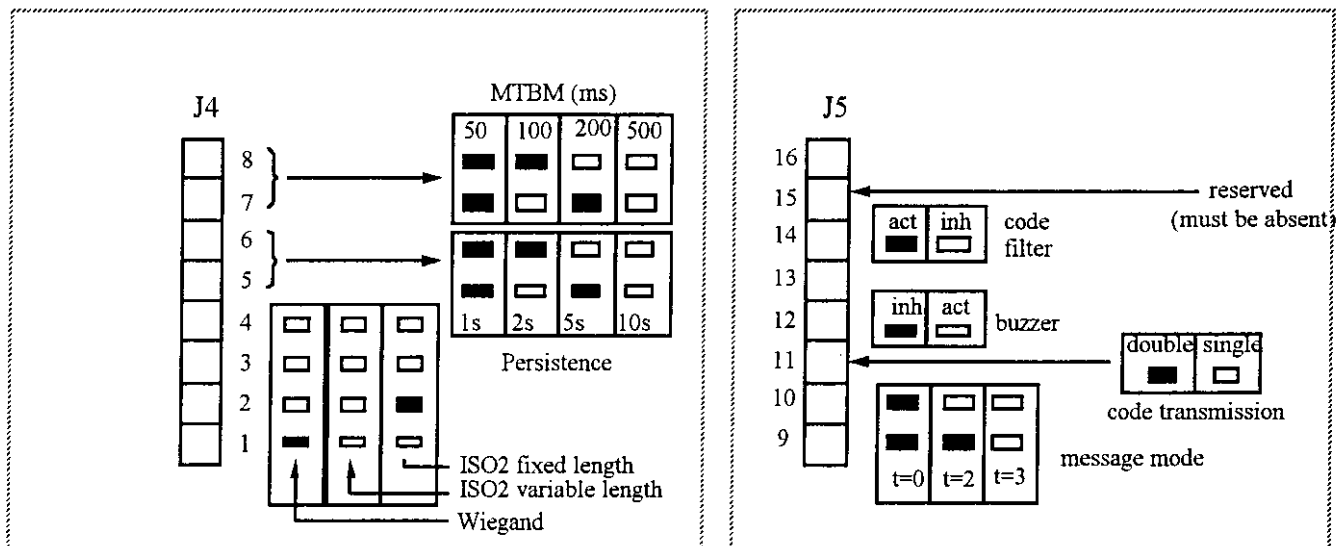

Configuring the electrical interface :

Jumpers for connectors J3 (10 positions, 1 to 10) and J8 (2 positions, 11 and 12 !) must be positioned as indicated below :

interface	positions J3	positions J8
ISO2/WIEG	3, 5, 8	—

9. APPENDIX B : SWITCH SETTINGS FOR MODULAR READER NEW VERSION

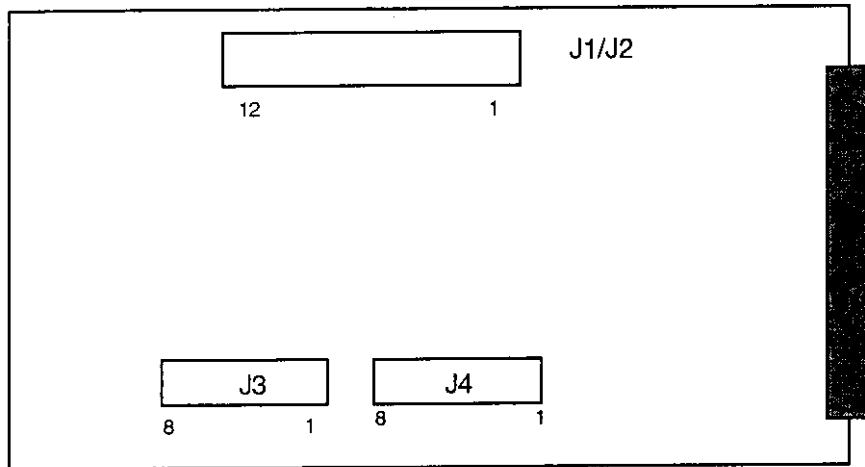

Interface J1

12 11 10 9 8 7 6 5 4 3 2 1

Address J4

8 7 6 5 4 3 2 1

ASYNCHRONOUS

ISO2 / WIEGAND

Interface Settings:

- RS 232
- RS 422
- RS 485
- ISO2 / WIEGAND
- MINITEL

Reader addresses:

- 1
- 2
- 3
- 4
- 5
- 6
- 7
- 8
- 9
- 10
- 11
- 12

Hold time:

- 1 s
- 2 s
- 5 s
- 10 s

MTBM:

- 1 s
- 100 ms
- 200 ms
- 500 ms

Baud rate:

- 9600
- 4800
- 1200
- 19200

character format:

- 7/even
- 7/odd
- 8/none

WIEGAND ISO2 variable ISO2 fixed

Note :

- Switch is OFF
- Switch is ON

CLASSIFICATION SOCIETE/ CLEARANCE LEVEL	REFERENCES DU DOCUMENT / DOCUMENT REFERENCES						PAGE
	Code Fabricant / Manufact. Code	Numéro / Number	Code Doc / Doc. Code	Tome / Volume	Indice / Revision Index	Langue Language	
NON							46

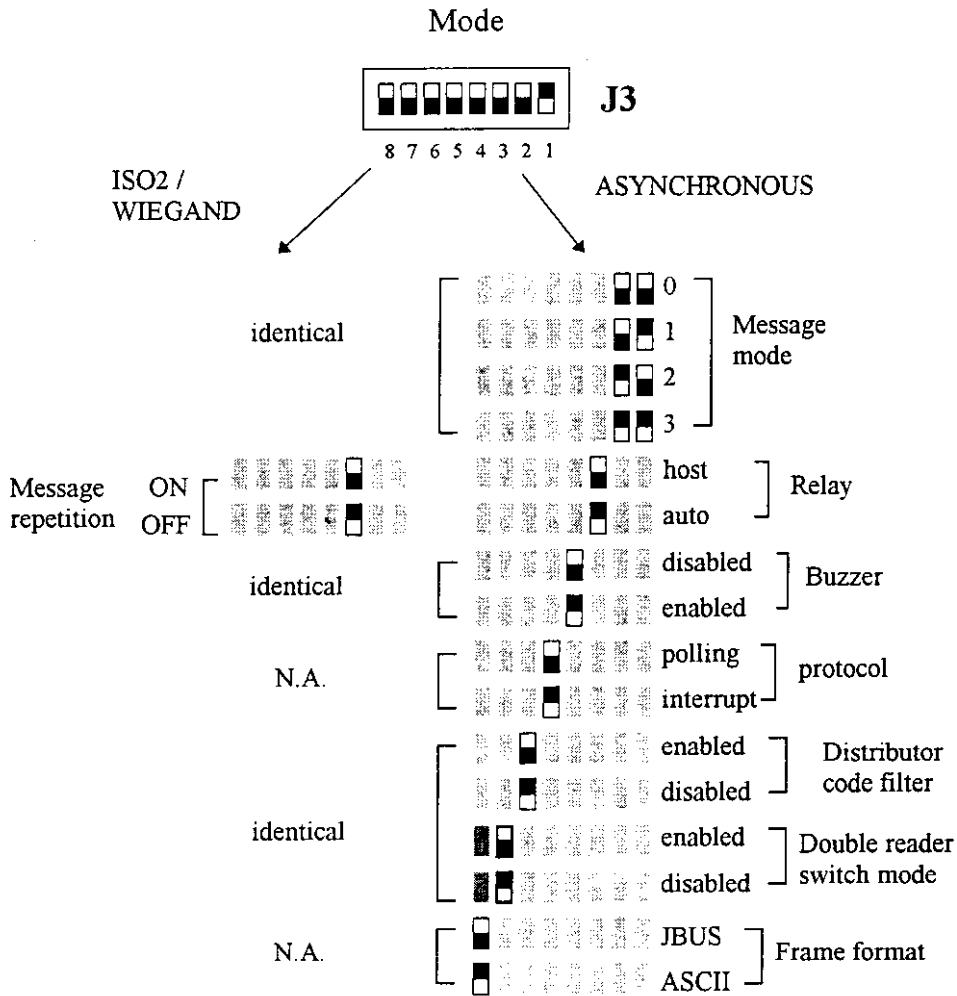

Note :

Switch is OFF

Switch is ON

CLASSIFICATION SOCIETE/ CLEARANCE LEVEL	REFERENCES DU DOCUMENT / DOCUMENT REFERENCES						PAGE
NON PROTEGE	Code Fabricant / Manufact. Code	Numéro / Number	Code Doc / Doc. Code	Tome / Volume	Indice / Revision Index	Langue Language	
	F0057	46 322 790	104		B	E	47

10. APPENDIX C : SWITCH SETTINGS FOR COMPACT READER

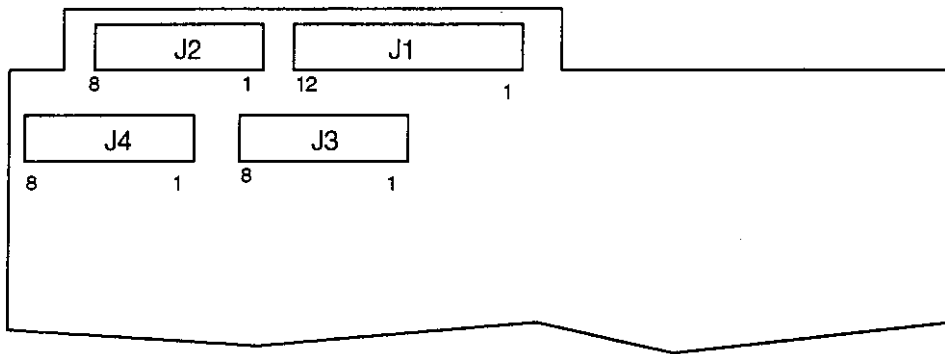

Interface **Address**

J1

12 11 10 9 8 7 6 5 4 3 2 1

ASYNCHRONOUS

J2

8 7 6 5 4 3 2 1

ISO2 / WIEGAND

Interface

- RS 232
- RS 422
- RS 485
- ISO2 / WIEGAND
- MINITEL

Reader addresses

- 1
- 2
- 3
- 4
- 5
- 6
- 7
- 8
- 9
- 10
- 11
- 12

WIEGAND

ISO2 variable

ISO2 fixed

Baud rate

- 9600
- 4800
- 1200
- 19200

Hold time

- 1 s
- 2 s
- 5 s
- 10 s

MTBM

- 1 s
- 100 ms
- 200 ms
- 500 ms

character format

- 7/even
- 7/odd
- 8/none

Note : Switch is OFF

Switch is ON

CLASSIFICATION SOCIETE/ CLEARANCE LEVEL	REFERENCES DU DOCUMENT / DOCUMENT REFERENCES						PAGE
NON	Code Fabricant / Manufact. Code	Numéro / Number	Code Doc / Doc. Code	Tome / Volume	Indice / Revision Index	Langue Language	
PROTEGE	50057	46 322 790	104		P	E	49

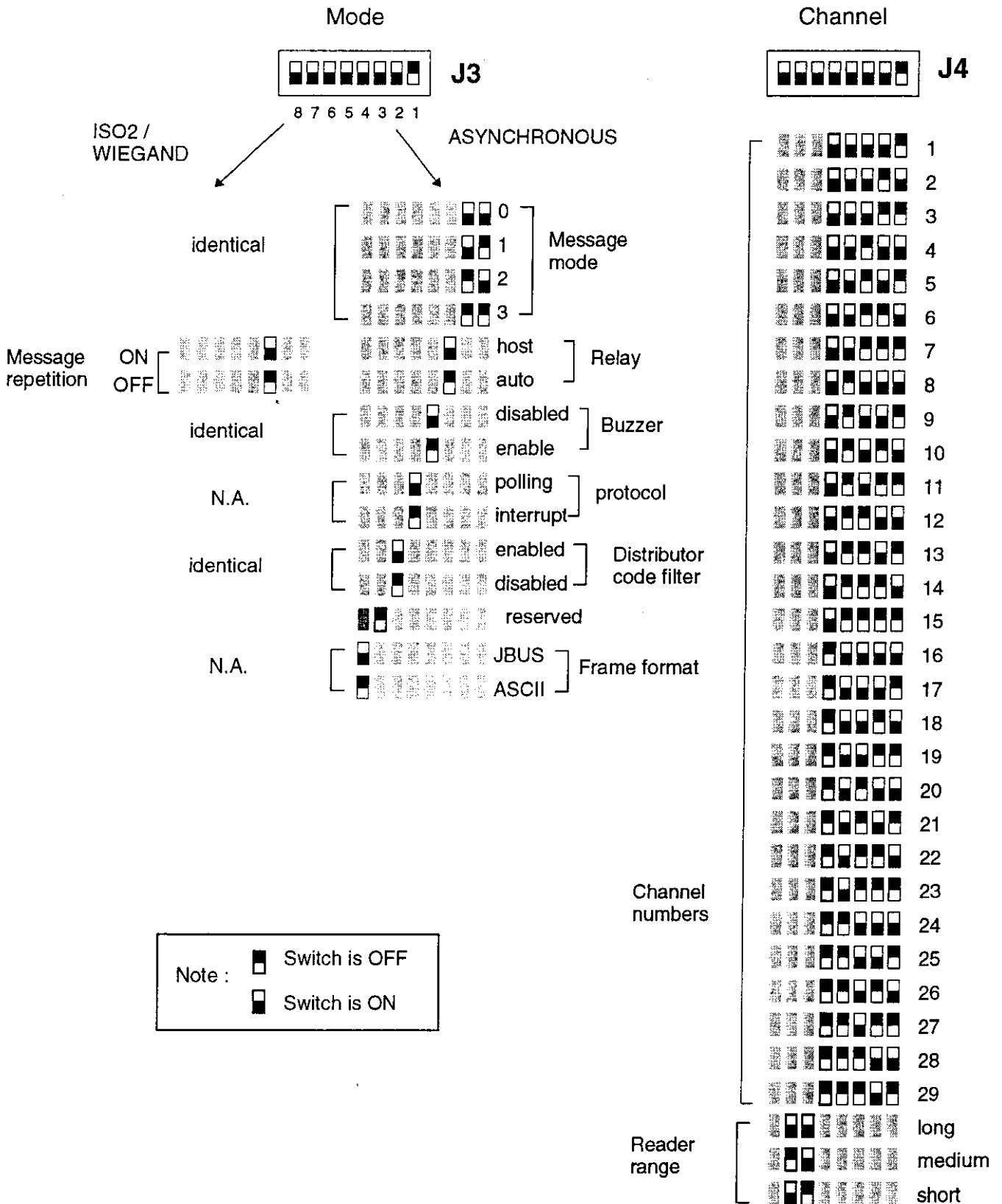

CLASSIFICATION SOCIETE/ CLEARANCE LEVEL	REFERENCES DU DOCUMENT / DOCUMENT REFERENCES						PAGE
NON PROTEGE	Code Fabricant / Manufact. Code	Número / Number	Code Doc / Doc. Code	Tome / Volume	Indice / Revision Index	Langue Language	
	F0057	46 322 790	104		B	E	49

11. APPENDIX D : DESCRIPTION OF TEST MODE

The information transmitted from the reader to the host normally uses a JBUS frame format.. During system installation, the host computer may not yet be connected or available. For this reason , an ASCII transmission mode exists, allowing the connection of a dumb terminal in order to visualize the messages sent and thus to verify correct system operation. This is called **test** mode and is enabled using a board jumper configuration

This mode has the following characteristics :

- interrupt mode is used (the tag-code is sent immediately)
- tag persistence = 1 second
- frame structure = 24H / status tag / 20H / code / 0DH / 0AH
- transmission characteristics (baud rate and character format) must be configured

Example:

During system installation, the reader is put into test mode. A terminal is connected to the reader via an RS-232 link. Transmission characteristics of reader and terminal are matched, and tags are held in front of antenna. The terminal will display messages of the type :

```
$0 001ABCDEF-100
$2 XYZHYPER X.007
```

The messages have the following structure :

\$ <status badge>(space) <distributor code> <user code>

where status badge : 0 = antenna 1, tag battery good
 1 = antenna 1, tag battery low
 2 = antenna 2, tag battery good
 3 = antenna 2, tag battery low

distributor code : nnn where n is a digit (0 à 9)

user code : from 1 to 30 characters, see chapter 6.4.3.

message	antenna	battery	distr. code	user code
0 001ABCDEF-100	1	good	001	ABCDEF-100
2 XYZHYPER X.007	2	good	XYZ	HYPER X.007

CLASSIFICATION SOCIETE/ CLEARANCE LEVEL	REFERENCES DU DOCUMENT / DOCUMENT REFERENCES						PAGE
	Code Fabricant / Manufact. Code	Numéro / Number	Code Doc / Doc. Code	Tome / Volume	Indice / Revision Index	Langue Language	
NON PROTEGE	F0057	46 322 790	104		B	E	50

12. APPENDIX E : ALGORITHM FOR CALCULATING THE CRC16

It is a 16 bit field. The calculation is performed on all bytes preceding the field.

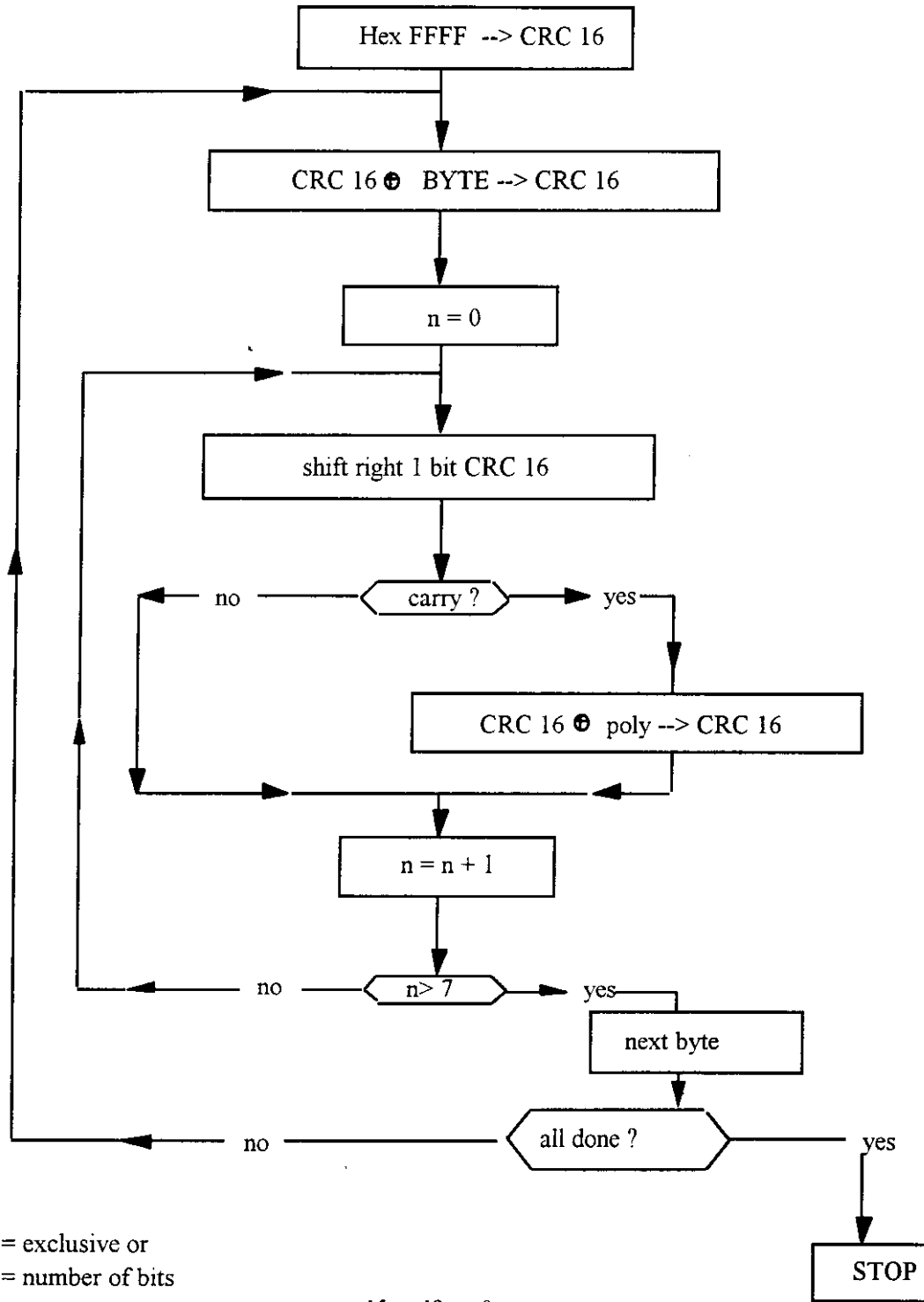

CLASSIFICATION SOCIETE/ CLEARANCE LEVEL	REFERENCES DU DOCUMENT / DOCUMENT REFERENCES						PAGE
	Code Fabricant / Manufact. Code	Numéro / Number	Code Doc / Doc. Code	Tome / Volume	Indice / Revision Index	Langue Language	
NON	50057	46 202 700	104		B	E	51

