



OWNER'S MANUAL

28" GRIDDLE COOKING STATION

MODEL # 1554



FOR OUTDOOR USE ONLY
PLEASE READ MANUAL CAREFULLY BEFORE ASSEMBLY
RETAIN THIS MANUAL FOR FUTURE REFERENCE

WARNING:

Hazardous fire or explosion may result if instructions are ignored.

It is the consumer's responsibility to see that the grill is properly assembled, installed, and taken care of. Failure to follow the instructions in this manual could result in bodily injury and/or property damage.

FOR YOUR SAFETY IF YOU SMELL GAS:

1. Turn off gas supply at bottle.
2. Extinguish all open flames; do not operate any electrical appliances.
3. Ventilate the area.
4. Check for leaks as detailed in this manual.

PRECAUTIONS:

1. Leak test all connections after each tank refill.
2. Never check for leaks with a match or open flame.
3. Do not store gasoline or other flammable vapors and liquids in the vicinity of this or any other appliance.
4. Any LP cylinder not connected for use should not be stored in the vicinity of this or any other appliance.

ASSEMBLY

WARNING: The manufacturer has made every effort to eliminate any sharp edges. However, you should handle all components with care to avoid accidental injury.

Tools required: Blackstone griddles have been manufactured in such a convenient fashion that there no tools necessary for assembly.

ASSEMBLY:

Please read all instructions thoroughly before proceeding. Find a large, clean area in which to assemble your grill. Please refer to the assembly diagram as necessary. Assembly of the grill involves large components; it is advised to have two people assemble the unit.

NOTICE: Make sure all the plastic protection is removed before assembling!

EXPANDED VIEW

- 1- Griddle Top
- 2- Griddle drip dish
- 3- Side Shelf
- 4- Cross Bar
- 5- Cross Bar Thumb Screw
- 6- Removable Drip tray

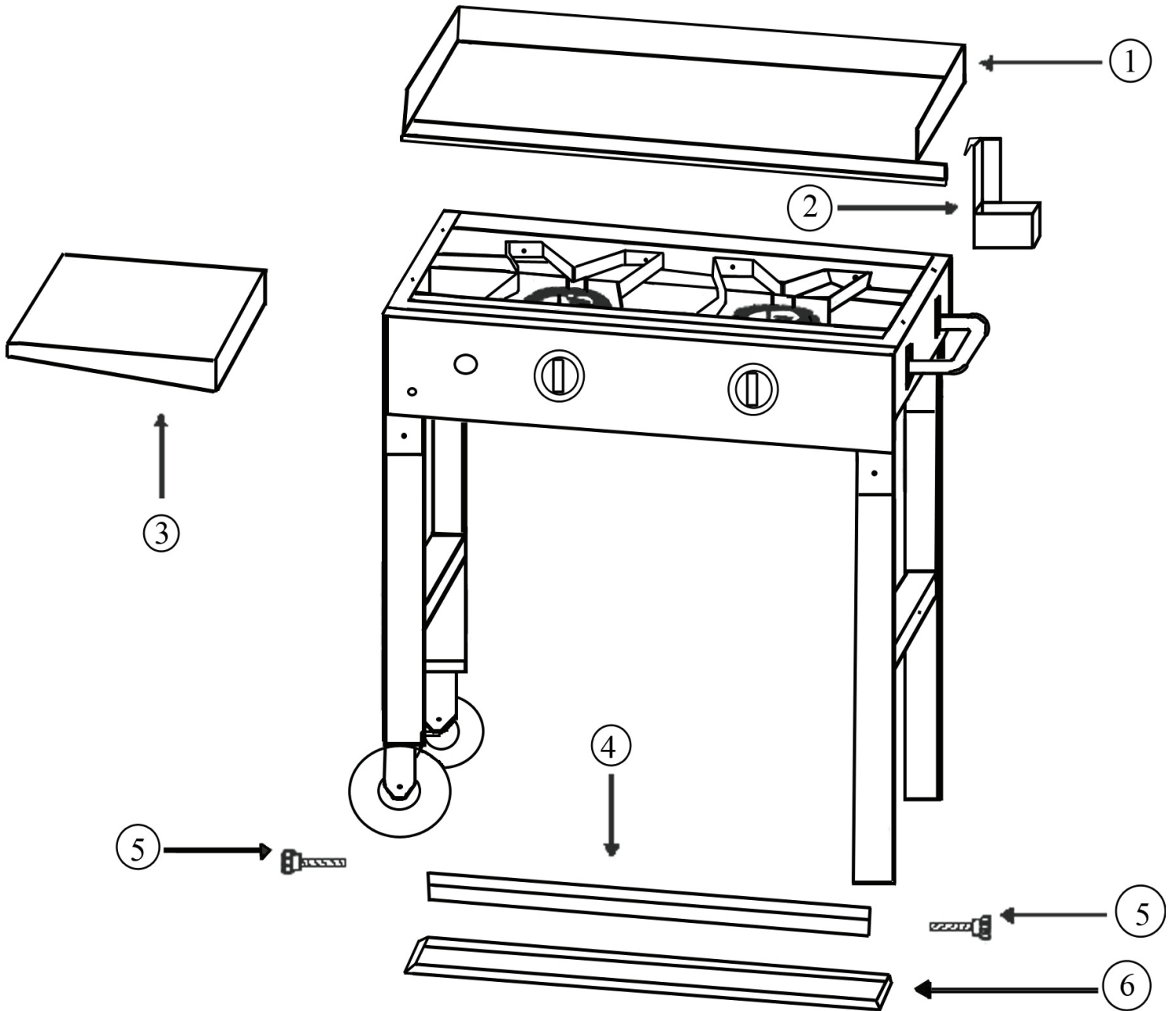

ASSEMBLY

Step 1

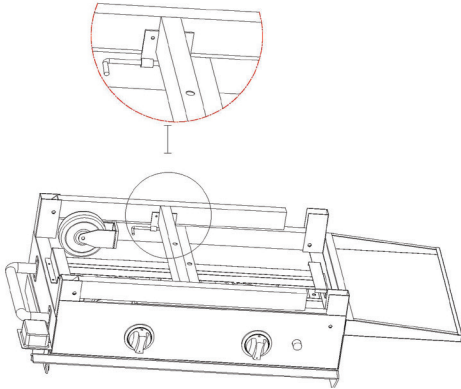

**Actual locking mechanism may vary from picture*

Step 2

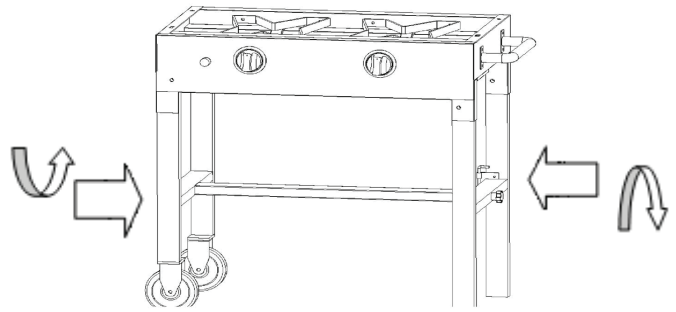

Step 3

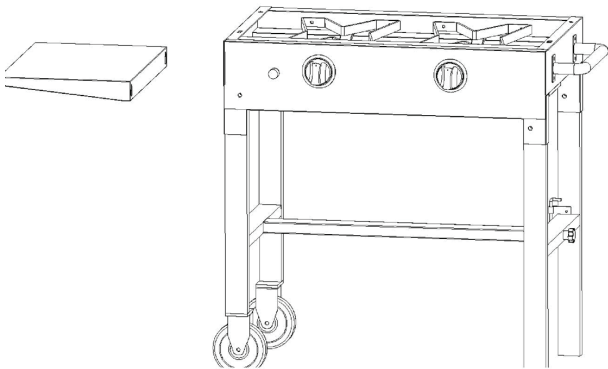

Step 4

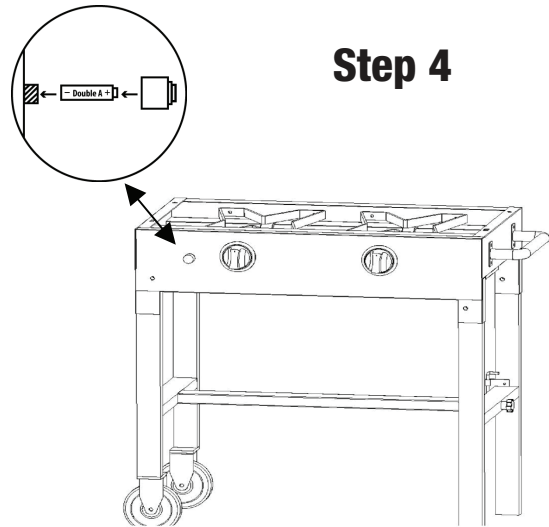

Step 5

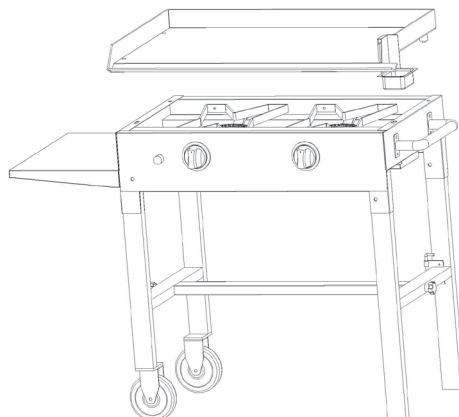

IMPORTANT INFORMATION

Please read these instructions carefully before assembly and use.

- Retain these instructions for future reference.
- For **outdoors** only-do not use indoors.
- For use with LPG bottled gas only.
- Do not use in an area with flammable structures or surface.
- LPG gas cylinders must not be stored and used in a upright position. A leak would be very serious and liquid could enter the gas line.
- Do not move the grill while it is in use.
- This grill must not be left unattended when it is being used.
- Parts of this grill become very hot. Care must be taken when children, elderly people, and animals are present.
- Always turn off the gas bottle when the grill is not in use.
- Never cover a grill until it has completely cooled.
- Leak test annually and whenever the gas bottle is removed or replaced.
- Do not store flammable materials near this grill.
- Do not use aerosols near this grill.
- Failure to follow these instructions could result in serious injury and/or damage.
- If you have any queries regarding these instructions, contact your local dealer.

GAS AND REGULATOR:

This grill can use either propane or butane LPG bottle gas. You must have the proper regulator and bottle in order for the grill to operate safely and efficiently. Use of an incorrect or faulty regulator is dangerous and will invalidate any warranty. Please consult your local gas dealer for the most suitable gas bottles and regulators.

INSTALLATION

LOCATION:

This grill is for **outdoor** use only and should be placed in a well-ventilated area. Take care to ensure that it is not placed under any combustible surface. The sides of the grill should **NEVER** be closer than 2 feet from any combustible surface. Keep this grill away from any flammable materials!

PRECAUTIONS

Do not obstruct any ventilation openings in the body of the grill. Position the gas supply bottle on level ground next to the grill and safely away from any source of heat. Should you need to change the gas bottle, confirm that the grill is turned off and that there are no sources of ignition (cigarettes, open flame, sparks, etc) nearby. Before proceeding, inspect the gas hose to ensure it is free of any twisting or tension.

The hose should hang freely with no bends, folds, or kinks that could obstruct free flow of gas. Apart from the connection point, no part of the hose should touch any hot grill parts. Always inspect the hose for use with LPG and meet the national standards for the country of use.

FIXING THE REGULATOR TO THE GAS BOTTLE:

Confirm all grill control knobs are in the off position. Connect the regulator to the gas bottle according to your regulator and bottle dealer's instructions.

Leak testing

Confirm that you are in a well-ventilated area and that all grill control knobs are in the off position. Open the gas control valve on the bottle or regulator. Check for leaks by brushing a solution of ½ water and ½ soap over all gas system joints, including all valve connections, hose connections, and regulator connections.

NEVER USE AN OPEN FLAME to test for leaks at anytime. If bubbles form over any of the joints, there is a leak. Turn off the gas supply and retighten all joints. Repeat test. If bubbles form again, do not use the grill and contact customer service. Leak test annually, and whenever the gas bottle is removed or replaced. Always remember that before use, take care to ensure that no bubbles have formed over any of the joints.

OPERATION

WARNINGS:

- Before proceeding, make certain that you understand the IMPORTANT INFORMATION section of this manual.

Preparation before cooking:

To prevent foods from sticking to the cooking grill, please use a long handled brush to apply a light coat of cooking or vegetable oil before each grilling session. (Note: when cooking for the first time, paint colors may change slightly as a result. This is normal and should be expected.)

Lighting the grill:

1. In order for the igniter switch to work, please make sure the battery is properly installed.
2. Ensure all knobs are in the "OFF" position. Open the gas control valve on the gas bottle or regulator.
3. Open the gas control valve at the cylinder.
4. From "OFF" position, push down the front left control knob and keep pressing while turning counter clockwise to the "HIGH" position and pressing the ignition button (you will hear a clicking sound), this will light the left hand burner.
5. If burner fails to light, turn to "OFF" position and wait five minutes. Then begin again with step 3.

If burner still fails to light after several attempts, try the manual ignition procedure below.

6. When the left hand burner is lit the remaining burner can be lit by repeating steps 3 and 4.
7. To preheat the griddle, place the knob on “HIGH” position for 3-5 minutes.
8. After use, turn all control knobs to the “OFF” position and turn off the gas control valve at the cylinder.

MANUAL IGNITION PROCEDURE:

1. Take out removable grease drip tray.
2. Open the gas control valve at the cylinder.
3. Insert lit match through the space vacated by grease drip tray on the left side of the burner.
4. Push and turn the knob closest to the piazza lighter counter clockwise to the “HIGH” position and light with match.
5. If the burner fails to light after 5 seconds, turn to “OFF” position and wait 5 minutes. Then begin again from step 2. If the burner fails to light after several attempts, go to step 6, and call customer service.
6. After successfully lighting the first burner, turn next control knob to the “HIGH” position. The gas will ignite from lit burner on the left. Follow the same procedure for each successive burner. Light the remaining burners from left to right.
7. After use, turn all control knobs to the “OFF” position and turn off the gas control valve at the cylinder. **NOTE:** If the flame of the burner has a yellow hue, adjust the aeration screw located on the neck of the burner. The burner flame should be blue. Blue hued flames are confirmation that the burner is burning properly. Turning the screw counter clockwise will increase the amount of blue and clockwise will increase the amount of yellow.

End of cooking session:

Do not allow your grill to overheat. After each cooking session, turn the grill burners to the “HIGH” position and burn for 5 minutes. This procedure will burn off cooking residue, thus making cleaning easier.

Turning off your grill:

When you have finished using your grill, turn all of the control valves fully clockwise to the “OFF” position, then turn off the gas at the bottle. Wait until the grill is sufficiently cool before storing.

CARE AND MAINTENANCE

Regularly clean your grill between uses and especially after extended periods of storage. Ensure that the grill and its components are sufficiently cool before cleaning.

- Never handle hot parts with unprotected hands.
- In order to extend and maintain the life and condition of your grill, we strongly recommend that the unit be covered when left outside for any length of time, especially during the winter months.

Care and Cleaning:

1. A good grill scraper is essential for easy clean up.
2. Most foods can be cleaned up by scraping and wiping down the griddle with a paper towel and cooking oil to prevent rust.
3. To remove tough food residue you can use a mild cream cleaner and pad. You can also use soapy water or a paper towel and ¼ cup of table salt as another method of cleaning your griddle. Rinse well and dry to prevent rusting. Since the griddle surface is steel, you should protect it from moisture. To do this, spray the griddle with a light coating of vegetable oil and store in a dry area.
4. Periodically, griddle should be cleaned with a griddle brick or SOS pad.

Burner maintenance:

In most circumstances, burning off the residue after cooking will keep the burner clean. The burners should be removed and cleaned annually or whenever heavy build-up is found, to ensure that there are no signs of blockage (debris, insects) in either the burner portholes or the venture tubes. Use a pipe cleaner to clear obstructions. A wire brush can be used to remove corrosion from the burner surfaces. When refitting the burner, be careful to check that the venture tubes of the burner fit over the valve outlets.

Grill body:

Regularly remove excess grease or fat from the grill body with a soft plastic or wood scraper. It is not necessary to remove all of the grease from the body. If you need to clean fully, use hot soapy water and a cloth, or nylon-bristled brush only. Remove cooking surfaces and burners before cleaning. Do not immerse the gas controls or manifold in water. Check burner operation after carefully refitting into the body.

Fittings and Storage:

Annual checking and tightening of metal fittings is recommended. Store the grill in a cool dry place. Cover the burners with aluminum foil in order to prevent insects or other debris from collecting in the burner holes. If the grill is to be stored indoors, the gas bottle must be disconnected and left outside. The gas bottle should always be stored outside, out of reach of children, and in a dry, well-ventilated area away from any sources of heat or ignition.

TROUBLE SHOOTING

PROBLEM	POSSIBLE CAUSE	SOLUTION
Burner will not light using the ignition system.	<ol style="list-style-type: none"> 1. Check battery. 2. LP gas cylinder is empty. 3. Faulty regulator. 4. Obstructions in the burner. 5. Obstructions in gas jets or gas hose. 6. Electrode wire is loose or disconnected on electrode or ignition unit. 7. Electrode or wire is damaged faulty pushbutton igniter. 	<ol style="list-style-type: none"> 1. Replace with a good battery. 2. Replace with full cylinder. 3. Have the regulator checked or replaced. 4. Clean burner. 5. Clean jets and gas hose. 6. Reconnect wire. 7. Change electrode and wire change igniter.
Burner will not light with a match.	<ol style="list-style-type: none"> 1. LG gas cylinder is empty. 2. Faulty Regulator. 3. Obstructions in burner. 4. Obstructions in gas jets or gas hose. 	<ol style="list-style-type: none"> 1. Replace with full cylinder. 2. Have the regulator checked or replaced. 3. Clean Burner. 4. Clean jets and gas hose.
Fire in burner tube has a low flame or flashback (a hissing or roaring noise may be heard)	<ol style="list-style-type: none"> 1. LP gas cylinder is empty. 2. Obstructions in burner. 3. Obstructions in gas jets or gas hose. 4. Windy conditions. 	<ol style="list-style-type: none"> 1. Use larger cylinder. 2. Clean burner. 3. Clean jets and gas hose. 4. Use grill in a more sheltered position.

North Atlantic Imports 90-Day Warranty

North Atlantic Imports the manufacturer, will warranty for 90 days from purchase all parts, workmanship, and finishes (against rust).

It will be the manufacturer's option as to whether to repair or replace any of the above items.

All warranties are limited to the original purchaser only. This warranty does not cover any liability on the part of North Atlantic Imports, its agents or employees, for any indirect or consequential damages for breach of warranty.

The purchaser must follow the manufacturer's usage instructions.

Under no circumstances is the manufacturer responsible for damages from the failure to operate the grill/griddle properly.

It is the responsibility of the purchaser to establish the warranty period by verifying the original purchase date with original sales receipt.

For more detailed explanation of the warranty, read below:

North Atlantic Imports warrants to the owner that the product covered by this agreement is free from defects in material and workmanship under normal use and service for which it was intended if, but only if, it has been operated in accordance with North Atlantic Imports instructions exclusively for domestic use, and not for private or public club, institutional, or commercial purposes. North Atlantic Imports obligation under this warranty is limited to replacing or repairing, free of charge, any part or parts that may prove, to the satisfaction in North Atlantic Imports, to be defective under normal home use and service within the following stated periods of time from the date of purchase; a) for ninety (90) days from purchase, all parts, finish, and workmanship. Should any failure to conform to this warranty become apparent during applicable warranty periods stated above, the original purchaser must notify North Atlantic Imports of breach or warranty within the applicable warranty period. North Atlantic Imports shall upon notice and compliance by the original purchaser with such instructions, correct such nonconformity by repair or replacement of the defective part or parts. Correction in the manner provided above shall constitute a fulfillment of all obligations of North Atlantic Imports with respect to the quality of the product.

North Atlantic Imports does not warrant this equipment to meet the requirement of any safety code of any state, municipality or other jurisdiction, and the original purchaser assumes all risk and liability whatsoever resulting from the use thereof, whether used in accordance with North Atlantic Imports instructions or otherwise. This warranty does not cover and is intended to exclude any liability on the part of North Atlantic Imports its agents, servants or employees whether under this warranty or implied by law for any indirect or consequential damages for breach on any warranty. The purchaser must establish all applicable warranty periods pursuant to this warranty by verifying the original purchase date by producing the dated sales receipt. This warranty shall not apply to this product or any other part thereof which has been subject to accident, negligence, alteration, abuse, or misuse or which has been repaired or altered without Cache Sales written consent, outside of North Atlantic Imports factory. North Atlantic Imports makes no warranty whatsoever in respect to accessories or parts not supplied with it. This warranty shall apply only within the boundaries of the United States of America. This warranty gives the original purchaser specific rights, and the original purchaser may also have other rights, which vary from state to state.

Our Customer Service staff is here to help you. You may contact us at:

(435) 252-3030

or

support@blackstoneproducts.com

We're pleased to help you with any questions concerning replacement parts or your warranty. Our customer service staff can be reached Monday through Friday from 8:00 am to 5:00 pm Mountain Time. If all operators are busy or you call after hours, you may leave a message and your call will be returned.

Optional Blackstone Accessories

Carry Bag



Cover

