



SAL-2 Series Wireless Clock Installation Manual (v1)

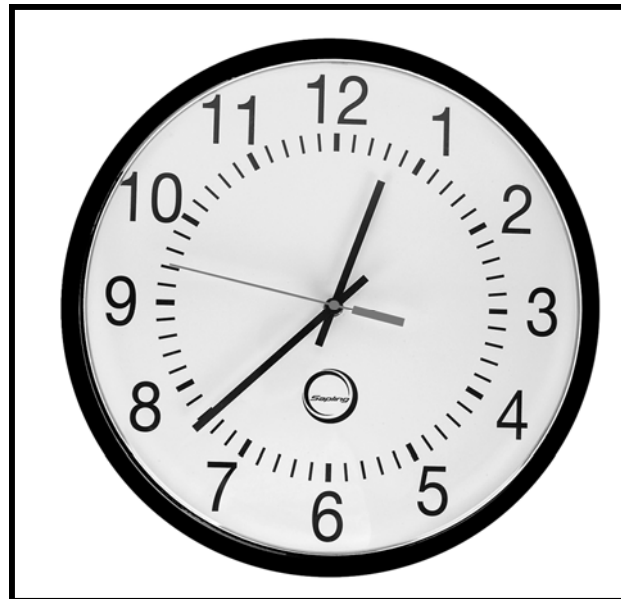

Table of Contents

MOUNTING

Wall Mount Installation..... Page 2

Double Mount Installation..... Page 3

WIRING INFORMATION

Wiring Information..... Page 4

OPERATION

Operational Instructions..... Pages 5 - 8

FREQUENTLY ASKED QUESTIONS

SAL Frequently Asked Questions..... Page 9

TROUBLESHOOTING

SAL Troubleshooting..... Page 10

DIAGNOSTIC TESTING

Diagnostic Tests Procedures..... Pages 11 - 13

FCC INFORMATION

FCC Information..... Page 14



SAL-2 Series Wireless Clock Installation Manual (v1)

Wall Mount Installation

24 Volt/110 volt options shown in diagrams

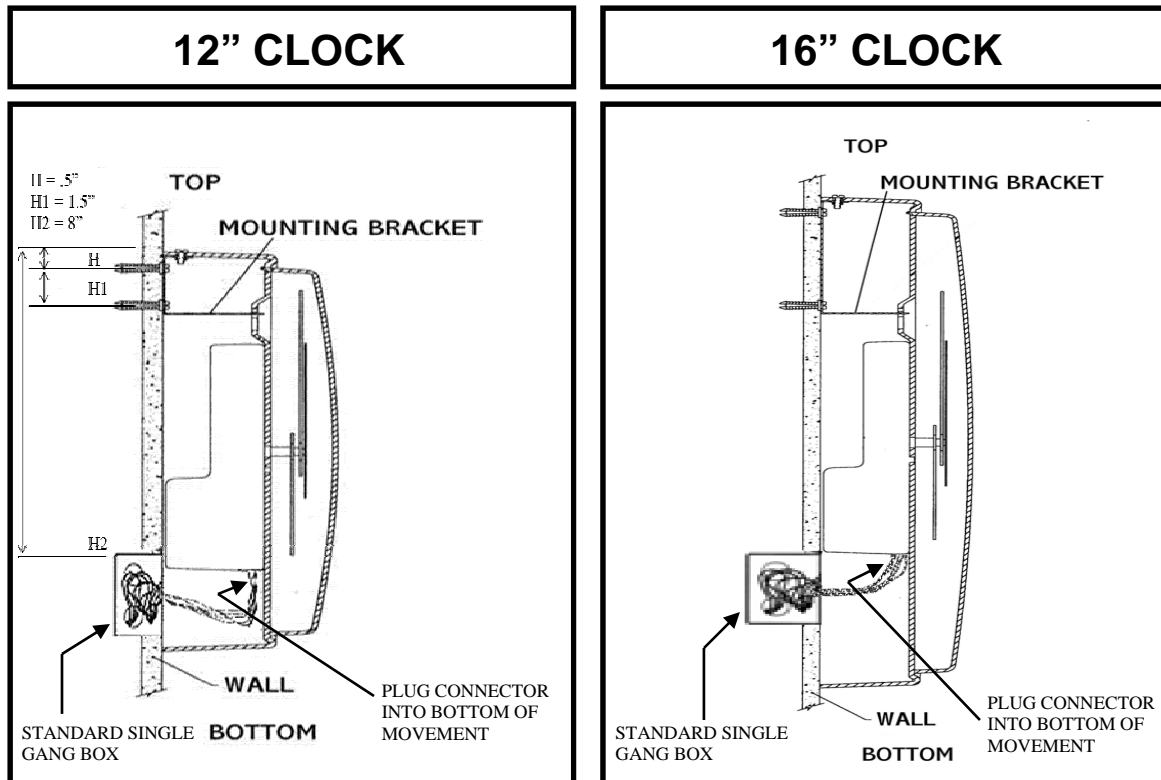

INSTRUCTIONS

1. Connect the wiring as shown on the wiring diagram (**110V or 24V ONLY**).
2. Mount both plastic anchors in the wall.
3. Insert the sheet metal screws (#10) through the mounting bracket into the plastic anchors.
4. Plug the connector into the movement (**110V or 24V ONLY**).
5. Hang the clock on the mounting bracket.
6. Put the screw (4mm) through the hole on the top of the clock into the hole at the top of the mounting bracket.



SAL-2 Series Wireless Clock Installation Manual (v1)

Double Mount Installation

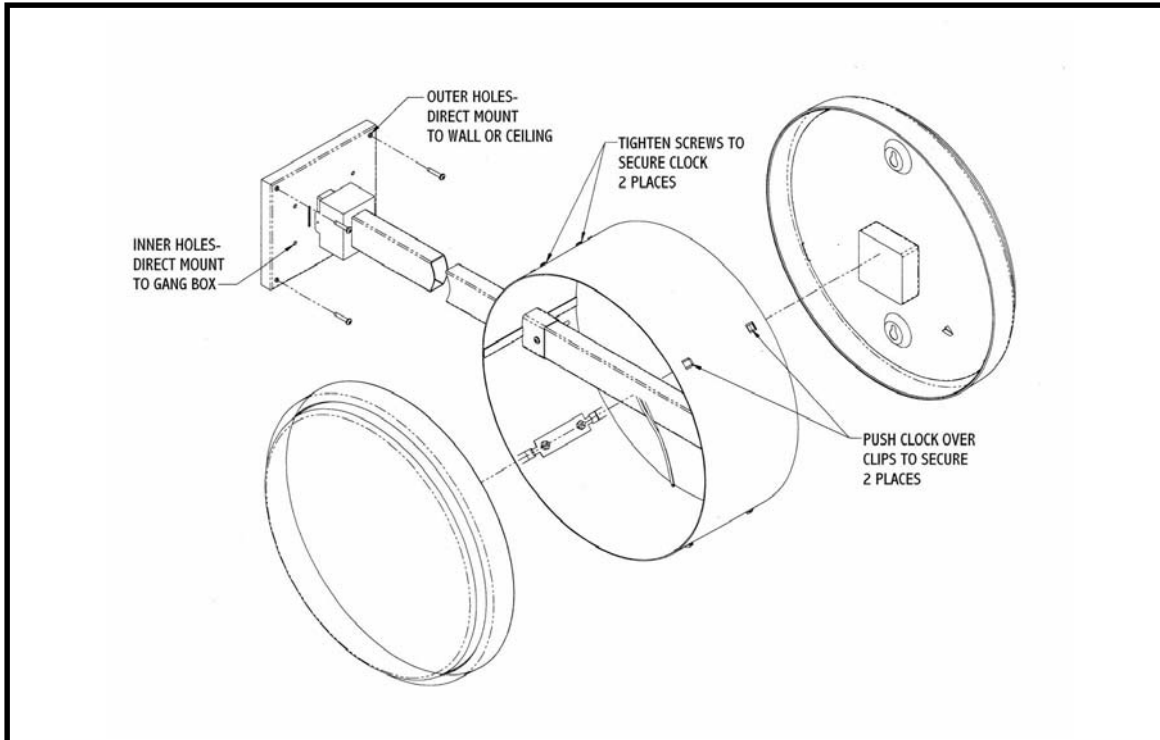

INSTRUCTIONS

1. Screw the mounting bracket to the double gang box using four (4) inner holes on mounting bracket, or mount the mounting bracket directly to the wall or ceiling using the four (4) outer holes.
2. Insert the wires through the mounting bracket (**110V or 24V ONLY**).
3. Fish the wires through the clock hanging rod.
4. Secure hanging rod to mounting bracket with screws supplied, and place cover over connection.
5. Connect the wiring as shown on the wiring diagrams.
6. Plug the connectors into the movements (**110V or 24V ONLY**).
7. Place the clocks on the double mount housing and tighten the screws to secure clocks as shown above.



SAL-2 Series Wireless Clock Installation Manual (v1)

Wiring Information

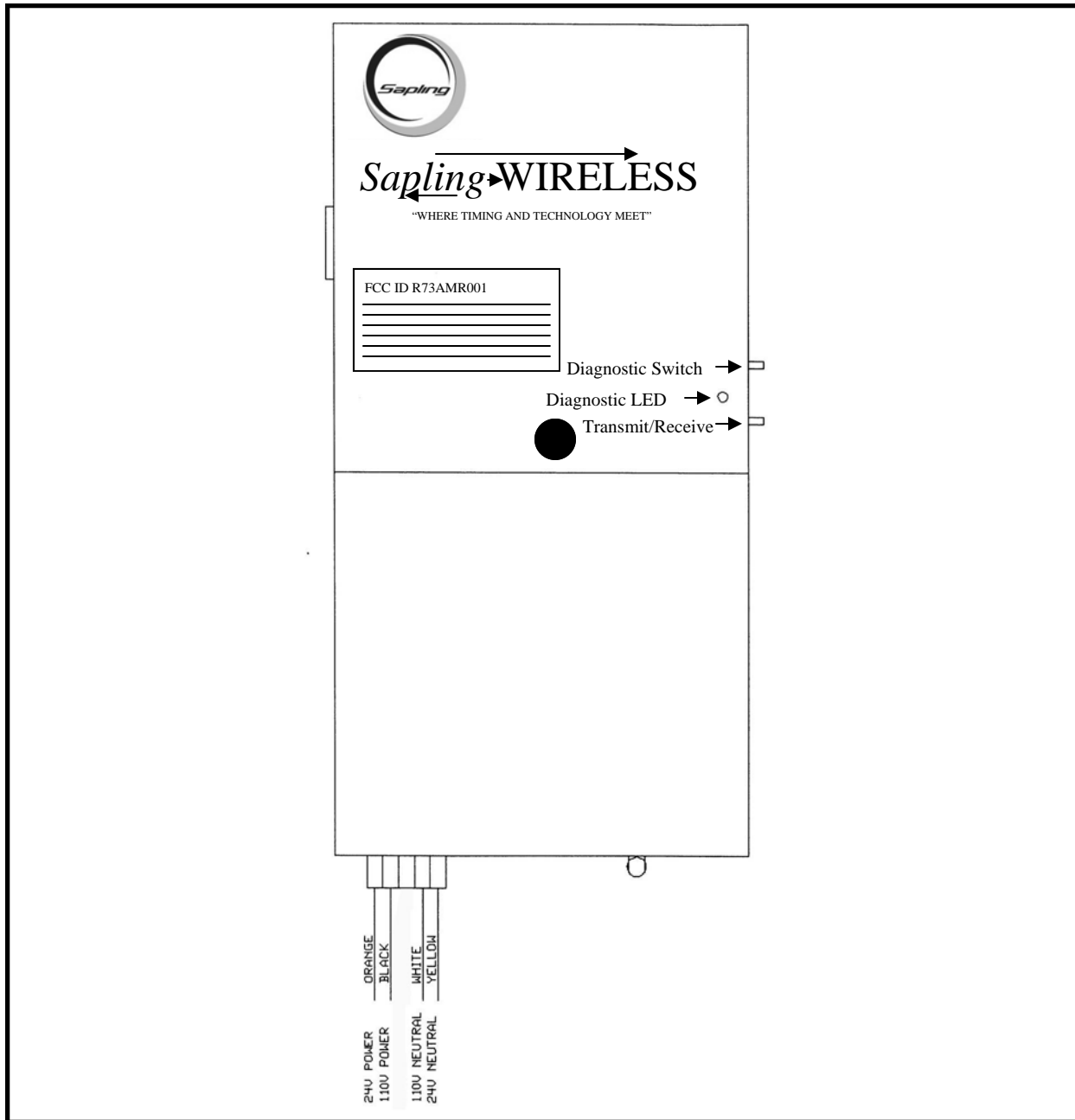

The Sapling SAL-2 Series clock can be powered by 2 “D” cell batteries, 24 volts AC, or 110 volts AC.



SAL-2 Series Wireless Clock Installation Manual (v1)

Operational Instructions

IMPORTANT: We highly recommend installing the main transceiver before the installation of the SAL Series clocks.

In order to install the clock, simply remove the battery cover, and install two (2) D cell batteries (recommended battery type: Duracell PROCELL; can be purchased through Sapling (Part # E-DBATT)). After installation of the battery, replace the battery cover and the clock should start correcting within five (5) minutes.

Normal Mode/Economy Mode

The SAL-2 Series clocks have two different modes in which they will operate. Normal mode allows the clock to transmit/receive every two (2) hours. This mode will allow the clock to have a 5 year battery life (provided good reception). Economical mode allows the clock to transmit/receive every four (4) hours. This mode will allow the clock to have a 8 year battery life (provided good reception).

Normal mode is defaulted when shipped from the factory.

To toggle this mode, push and release the Diagnostic Switch and the Transmit/Receive switch simultaneously. If 5 year mode is selected, the LED will be solid RED for one minute and the second hand will go to 5 (25 seconds). If 8 year mode is selected, the LED will be solid GREEN for one minute and the second hand will go to 8 (40 seconds).

IMPORTANT: If a clock is being added to an existing system, it must be in normal mode.

There are three (3) ways to operate Sapling's SAL Series Wireless System. The user can choose any of the combinations listed below, or any combination of the three (3).

Option #1:

There is a main high powered transceiver in the building and repeaters as needed to cover the entire premise. In this option, the system does not depend on the clock for transmission.

Option #2:

There is at least one (1) high powered transceiver in the building and in order to cover the entire premise, the **battery** operated clocks are used as transceivers/repeaters.

Option #3:

There is at least one (1) high powered transceiver in the building and in order to cover the entire premise, the **power (24V or 110V)** operated clocks are used as transceivers/repeaters.



Operational Instructions

Installation Option #1

There is a main high powered transceiver in the building and high powered transceivers or repeaters as needed to cover the entire premise. In this option, the system does not depend on the clock for transmission.

OPTION 1A: Transceivers or repeaters are synchronized wirelessly to the main transceiver.

1. Place the main transceiver in a central location (hallway recommended).
2. Pick the location of the second transceiver or repeater.
3. Place the transceiver/repeater in a location where the signal is available from the main transceiver. In order to verify that the transceiver is receiving a signal from the main transceiver, power up the transceiver and within five (5) minutes, it shall show the main transceiver time. If the transceiver did not correct to the main transceiver time, choose a different location for the transceiver.
4. Repeat the above mentioned steps with the corresponding transceivers or repeaters. Please note that the corresponding transceivers or repeaters can receive a signal from another transceiver or repeater, and not only from the main transceiver.

OPTION 1B: Transceivers or repeaters are synchronized via wire to the main transceiver.

1. Place the main transceiver in a central location (hallway recommended).
2. Run two (2) conductive wires between the main transceiver and the corresponding transceivers or repeaters in order to transmit the time between the units.

Installation Option #2

There is at least one (1) high powered transceiver in the building and in order to cover the entire premise, the **battery** operated clocks are used as transceivers/repeaters.

Clock Operational Overview (Battery Operation Version)

In order to reserve battery consumption, the receiver of the clock is enabled for ten (10) minutes upon power up. During normal operation, the clock enables its transceiver every two (2) hours (in normal mode). The clock also has the capability to transmit/receive during normal operation every four (4) hours (in economy mode).

There is a manual option, by pressing the Transmit/Receive switch twice to enable the receiver for ten (10) minutes in order to receive the time signal. In this case, the second hand will move to the twenty (20) second location until the signal is received, and then the clock will resume normal operation.



Operational Instructions

Installation Option #2 (continued)

There is another manual option, by pressing the Transmit/Receive switch once, to enable the clock transceiver for ten (10) minutes in order to transmit the time signal. The transceiver can be enabled only if the clock receives a time signal within the last twelve (12) hours. In this case, the second hand will move to the forty (40) second location, and after ten (10) minutes, the clock will resume normal operation.

IMPORTANT: We highly recommend installing the main transceiver before the installation of the SAL Series clocks.

The transceiver should be located in a central location, preferably in a hallway, so that there are a minimum number of walls between the transceiver and the clocks. After the installation of the transceiver, begin installing the clocks nearest to the transceiver; continue installing remaining clocks working from the transceiver as the central point. In order to install the clock, simply remove the battery cover, and install two (2) D cell batteries (recommended battery type: Duracell PROCELL; can be purchased through Sapling (Part # E-DBATT)). After installation of the battery, replace the battery cover and the clock should start correcting within five (5) minutes. If correction is not received within the first five (5) minutes, please follow these instructions. The steps on the following pages are recommended in order to synchronize the clock system for the first time. The steps are critical due to the fact that the clock receives and transmits every two (2) hours.

Option 2A

Go to the nearest clock (clock #1) that has received correction and press the Transmit/Receive switch once. The second hand should move to forty (40) seconds, and the clock should stop running. This is an indication that the clock is in transmission mode.

1. Go to the clock (clock #2) that did not receive transmission, and press the Transmit/Receive switch twice. The second hand should move to twenty (20) seconds until the clock receives signal from clock #1. Then clock #2 will display the master time within a five (5) minute period. Within ten (10) minutes of Step 1, clock #1 will resume operation and will go to the correct time.
2. Continue with the same process with all of the other clocks. Please note while one (1) clock is transmitting, you are not limited to the number of clocks that can go through the Step 2 process.

When moving further from the transceiver, you can repeat Step 1 and Step 2 using the clock that most recently received signal.

Option 2B (This option does not test that the distances between the clocks are sufficient)

1. Install the batteries in the clocks in the same area as the main transceiver.
2. After the clock has received signal from the transceiver and adjusted to the main transceiver time, place the battery cover on.
3. Take each clock, while running, to its designated area and install the clock.



Operational Instructions

Installation Option #3

There is at least one (1) high powered transceiver in the building in order to cover the entire premises. The *power (24V or 110V)* operated clocks are used as transceivers/repeaters.

Clock Operational Overview (Power Operation 24V or 110V Version)

The clock enables its receiver for ten (10) minutes upon power up and during normal operation every minute. The clock also has the capability to transmit every minute during normal operation or during power up once data is received.

We highly recommend installing the main transceiver before the installation of the SAL Series clocks. The transceiver should be located in a central location preferably in a hallway so that there are a minimum number of walls between the transceiver and the clock. After the installation of the transceiver, begin installing the clocks nearest to the transceiver; continue installing remaining clocks working from the transceiver as the central point. In order to install the clock, simply connect power to the clock using our pigtail connector.

Installation Option #4

This option allows the user to use multiple transmitters on a campus-like environment.

If a situation arises where the need is to have multiple buildings be synchronized with the wireless system, there are two options.

Option 4a

There is one transmitter and the clocks or repeaters send the signal to the other buildings.

This option is when the transmitter or the clocks are in range to the repeater in the other buildings. If the transmitter reaches the repeaters or clocks in the other building(s), the clocks will correct off of the repeater's transmission of the signal.

Option 4b

There is a transmitter in each building.



Frequently Asked Questions

What battery size do I use for the wireless clock?

The batteries required are two (2) "D" cell battery. The recommended battery type is "Duracell: Procell [D] size".

Will the clock cause interference with any of my other wireless devices?

No, the SAL Series wireless clock works on 915 - 928 MHz frequency-hopping technology. The clock switches frequencies automatically when the receiver and transceiver is open, thus interference is avoided.

Is there any advantage to a powered clock system as opposed to a battery operated system, assuming a single transceiver is in the building?

The powered wireless clock receives and transmits every minute and in locations where the signal is marginal, the likelihood of receiving a signal increases because of the frequent transmission rate.

What is the advantage of having multiple transceivers on a powered clock system?

Assuming the distances between the clocks is sufficient to receive the signal with an analog clock, there is no advantage of multiple transceivers on a powered system.

How long does it take for the clock to receive a signal?

Upon power up of the clock, the receiver will be turned on for a ten (10) minutes until the signal is acquired. If the user wishes to manually look for the signal, press the Transmit/Receive switch twice on the movement.

Can the clocks be set manually to display the correct time at installation (as a temporary measure until the master clock is installed)?

SAL clocks can NOT be set manually.



Troubleshooting

What happens if I power up the clock and the clock is not moving?

The clock should move at normal speed upon power up. If it does not move at normal speed, check the battery and make sure the clock receives power. Also, be sure to remove the pin prior to starting up the clock. If the clocks are 24 volt or 110 volt, please verify the wiring on page 4 of this manual.

What happens if the clock does not receive the signal?

Take the clock within close proximity to the transceiver and power up the clock. If the clock is battery operated, remove the battery and put the battery back in again.

Also, press the Transmit/Receive switch once on the clock closest to the clock that isn't working. The second hand will go to 8 notifying the user that the clock is transmitting the signal. Then go to the clock that isn't working and press the Transmit/Receive switch twice. The second hand will go to 4 notifying the user it is looking for the signal. This should get the signal to the clock.

If the clock does not correct, call Sapling technical support.

What happens if the clock shows the wrong time?

Move the clock to Diagnostic #1 in order to find the last time that it received the signal.

Perform a Diagnostic #3 to check the gears for the clock.

How do you know if the clock receives a good signal?

Perform Diagnostic #2. See page 12 for detailed instructions.

I have a location with a marginal signal. What should I do?

- a. Try to install the transceiver in a nearby area.
- b. If budget is an issue, install one (1) powered clock.

What can I do if I have a clock in a location where the distance is too far away from the last clock?

Install a repeater to give additional distance to the clock system.



Diagnostic Testing

Overview

The number of times that the switch is pressed will determine the diagnostic mode. After determining the diagnostic mode, the LED between the two (2) switches will start flashing a green light. The number of flashes will display the diagnostic number.

DIAGNOSTIC #1

This diagnostic will determine how long (# of hours) since the clock last received the communication signal.

In order to enter diagnostic one (1) mode, push the Diagnostic Switch once which is indicated by the green LED flashing one (1) time with a three (3) second break.

- A. While in diagnostic modes, hour and minute hands continue to run normally.
- B. The second hand will display how long since the clock received time signal (please see below table for details)
- C. After three (3) minutes, the clock will resume normal operation.

Second Hand Position	Time Since Clock Last Received a Communication Signal
12	Clock has received communication within the past hour
1	“ “ “ between one and two hours ago
2	“ “ “ between two and three hours ago
3	“ “ “ between three and four hours ago
4	“ “ “ between four and five hours ago
5	“ “ “ between five and six hours ago
6	“ “ “ between six and seven hours ago
7	“ “ “ between seven and eight hours ago
8	“ “ “ between eight and nine hours ago
9	“ “ “ between nine and ten hours ago
10	“ “ “ between ten and eleven hours ago
11	“ “ “ more than eleven hours ago



Diagnostic Testing

DIAGNOSTIC #2

This diagnostic will determine the quality of the time signal.

In order to enter Diagnostic #2 mode, push the Diagnostic Switch twice which is indicated by the green LED flashing twice with a three (3) second break.

- A. While in diagnostic modes, hour and minute hands continue to run normally.
- B. The second hand will display the quality of the time signal. (The signal percentage is displayed on the dial of the clock. It goes from 1 – 10, with 1 being the best signal strength and 10 being the least signal strength.
- C. After three (3) minutes, the clock will resume normal operation.

DIAGNOSTIC #3

This diagnostic will test the mechanical portion and some of the electronic components of the clock.

In order to enter Diagnostic #3 mode, push the Diagnostic Switch three times which is indicated by the green LED flashing three (3) times with a three (3) second break.

If an error occurs, the clock will flash the red LED to signal the error code number (please see table below) While in Diagnostic #3, the clock will perform the following steps:

- A. Clock moves second hand to 00.
- B. Clock moves second hand again to 00, to verify that the hands arrived after sixty (60) pulses.
- C. Clock moves minute and hour hands to the next known position.
- D. Clock moves minute and hour hands again to the same known position in order to verify that the hands reach the position after 720 pulses.
- E. Clock moves the hour and minute hands to 12:00:00.
- F. Test frequency, if battery it shall be D/C, other 60Hz/50Hz.

# of red Flashes	Diagnosis of Error Code
1,2	Clock detected problem with second hand. Check hands to see if they are hitting each other. Repeat test.
3,4,5	Clock detected problem with hour/minute hand. Check to see if they are hitting each other. Repeat test.
6	Call technical support



Diagnostic Testing

DIAGNOSTIC #4

This diagnostic will test the battery level of the clock.

In order to enter Diagnostic #4 mode, push the Diagnostic Switch four (4) times which is indicated by the LED flashing four times every three seconds.

The second hand will display the battery level by stopping one of the numbers on the clock's face.

For example:

- If the second hand lands on 2, the battery level 2.2V.
- If the second hand lands on 5, the battery level is 2.5V.
- If the second hand lands on 9, the battery level is 2.9V.
- If the second hand lands on 10, the battery level is 3V.
- If the second hand lands on 11, the battery level is more than 3V.



FCC Wants You to Know

This equipment has been tested and found to comply with the limits for a Class B digital device, pursuant to Part 15 of the FCC rules. These limits are designed to provide reasonable protection against harmful interference in a commercial installation. This equipment generates, uses and can radiate radio frequency energy and, if not installed and used in accordance with the instructions, may cause harmful interference to radio communications. However, there is no guarantee that interference will not occur in a particular installation. If this equipment does cause harmful interference to radio or television reception, which can be determined by turning the equipment off and on, the user is encouraged to try to correct the interference by one or more of the following measures:

- a) Reorient or relocate the receiving antenna.
- b) Increase the separation between the equipment and receiver.
- c) Connect the equipment to an outlet on a circuit different from which the receiver is connected.
- d) Consult the dealer or an experienced radio/TV technician.

FCC WARNING

Modifications not expressly approved by the manufacturer could void the user authority to operate the equipment under FCC Rules.

Note: For precautionary measures, FCC recommends a distance of 10cm from the clock to constant human physical exposure.