

28871(draft)

Digital Cordless Telephone and
Corded Speakerphone with Answering
System User's Guide

Equipment Approval Information

Your telephone equipment is approved for connection to the Public Switched Telephone Network and is in compliance with parts 15 and 68, FCC Rules and Regulations and the Technical Requirements for Telephone Terminal Equipment published by ACTA.

1 Notification to the Local Telephone Company

On the bottom of this equipment is a label indicating, among other information, the US number and Ringer Equivalence Number (REN) for the equipment. You must, upon request, provide this information to your telephone company.

The REN is useful in determining the number of devices you may connect to your telephone line and still have all of these devices ring when your telephone number is called. In most (but not all) areas, the sum of the RENs of all devices connected to one line should not exceed 5. To be certain of the number of devices you may connect to your line as determined by the REN, you should contact your local telephone company.

A plug and jack used to connect this equipment to the premises wiring and telephone network must comply with the applicable FCC Part 68 rules and requirements adopted by the ACTA. A compliant telephone cord and modular plug is provided with this product. It is designed to be connected to a compatible modular jack that is also compliant. See installation instructions for details.

Notes

- This equipment may not be used on coin service provided by the telephone company.
- Party lines are subject to state tariffs, and therefore, you may not be able to use your own telephone equipment if you are on a party line. Check with your local telephone company.
- Notice must be given to the telephone company upon permanent disconnection of your telephone from your line.
- If your home has specially wired alarm equipment connected to the telephone line, ensure the installation of this product does not disable your alarm equipment. If you have questions about what will disable alarm equipment, consult your telephone company or a qualified installer.

US Number is located on the cabinet bottom.

REN Number is located on the cabinet bottom.

2 Rights of the Telephone Company

Should your equipment cause trouble on your line which may harm the telephone network, the telephone company shall, where practicable, notify you that temporary discontinuance of service may be required. Where prior notice is not practicable and the circumstances warrant such action, the telephone company may temporarily discontinue service immediately. In case of such temporary discontinuance, the telephone company must: (1) promptly notify you of such temporary discontinuance; (2) afford you the opportunity to correct the situation; and (3) inform you of your right to bring a complaint to the Commission pursuant to procedures set forth in Subpart E of Part 68, FCC Rules and Regulations.

The telephone company may make changes in its communications facilities, equipment, operations or procedures where such action is required in the operation of its business and not inconsistent with FCC Rules and Regulations. If these changes are expected to affect the use or performance of your telephone equipment, the telephone company must give you adequate notice, in writing, to allow you to maintain uninterrupted service.

Interference Information

This device complies with Part 15 of the FCC Rules. Operation is subject to the following two conditions: (1) This device may not cause harmful interference; and (2) This device must accept any interference received, including interference that may cause undesired operation.

This equipment has been tested and found to comply with the limits for a Class B digital device, pursuant to Part 15 of the FCC Rules. These limits are designed to provide reasonable protection against harmful interference in a residential installation.

This equipment generates, uses, and can radiate radio frequency energy and, if not installed and used in accordance with the instructions, may cause harmful interference to radio communications. However, there is no guarantee that interference will not occur in a particular installation.

Privacy of Communications may not be ensured when using this product.

If this equipment does cause harmful interference to radio or television reception, which can be determined by turning the equipment off and on, the user is encouraged to try to correct the interference by one or more of the following measures:

- Reorient or relocate the receiving antenna (that is, the antenna for radio or television that is “receiving” the interference).
- Reorient or relocate and increase the separation between the telecommunications equipment and receiving antenna.
- Connect the telecommunications equipment into an outlet on a circuit different from that to which the receiving antenna is connected.

If these measures do not eliminate the interference, please consult your dealer or an experienced radio/television technician for additional suggestions. Also, the Federal Communications Commission has prepared a helpful booklet, “How To Identify and Resolve Radio/TV Interference Problems.” This booklet is available from the U.S. Government Printing Office, Washington, D.C. 040. Please specify stock number 004-000-00345-4 when ordering copies.

Notice: The changes or modifications not expressly approved by the party responsible for compliance could void the user's authority to operate the equipment.

Hearing Aid Compatibility (HAC)

This telephone system meets FCC standards for Hearing Aid Compatibility.

Licensing

Licensed under US Patent 6,427,009.

FCC RF Radiation Exposure Statement

This equipment complies with FCC RF radiation exposure limits set forth for an uncontrolled environment. This equipment should be installed and operated with a minimum distance of 20 centimeters between the radiator and your body. This transmitter must not be co-located or operated in conjunction with any other antenna or

transmitter.”

For body worn operation, this phone has been tested and meets the FCC RF exposure guidelines when used with the belt clip supplied with this product. Use of other accessories may not ensure compliance with FCC RF exposure guidelines.

Information for DECT Product



This telephone is compliant with the DECT 6.0 standard which operates in the 1.92GHz to 1.93GHz frequency range.

Battery Safety Precautions

- Do not burn, disassemble, mutilate, or puncture. Like other batteries of this type, toxic materials could be released which can cause injury.
- To reduce the risk of fire or personal injury, use only the battery listed in User’s Guide.
- Keep batteries out of children.
- Remove batteries if storing over 30 days.
- Do Not Use Alkaline or Non Rechargeable Batteries.



CAUTION:

Danger of explosion if battery is incorrectly replaced. Replace only with **5-2826 2.4V 600mAh** rechargeable battery or equivalent. Only use rechargeable batteries with exactly the same specifications as those supplied with the product. Using non-rechargeable or non-conforming batteries can damage the product. The batteries could split or leak if incorrectly inserted, opened or exposed to heat. Never dispose of batteries in a fire: the cell could explode. Check with local code for possible special disposal instruction.

Note: To ensure the battery charging properly, clean the charging contacts on the handset and charger with a soft, dry cloth once a

month. Clean more often if the unit is subject to grease, dust or high humidity.

Installation

Packaging Contents

Packaging contents	Single pack	Twin pack	Triple pack
Handset Base Stations	1	1	1
Cordless Handset	1	2	3
Mains Adaptor	2	3	4
Telephone Line Cord	1	1	1
Batteries, type AAA, 2.4V 600mAh”	1	2	3
Charging station	1	2	3
Operating instructions	1	1	1

Please check the contents of the package carefully. If anything is missing or shows signs of transport damage, do NOT put the telephone into service! In such a case, contact either your sales outlet with the purchase receipt.

Connecting the Base Station and Power Plug

Connecting the plugs to the corresponding sockets in the base station (they can not be connected incorrectly because the sockets and plugs are designed prevent reverse poling). Plug the telephone line in the telephone connection socket. Insert the power plug at the other end in the power outlet. The base station is now ready to operate.

Only use the connection cable supplied.

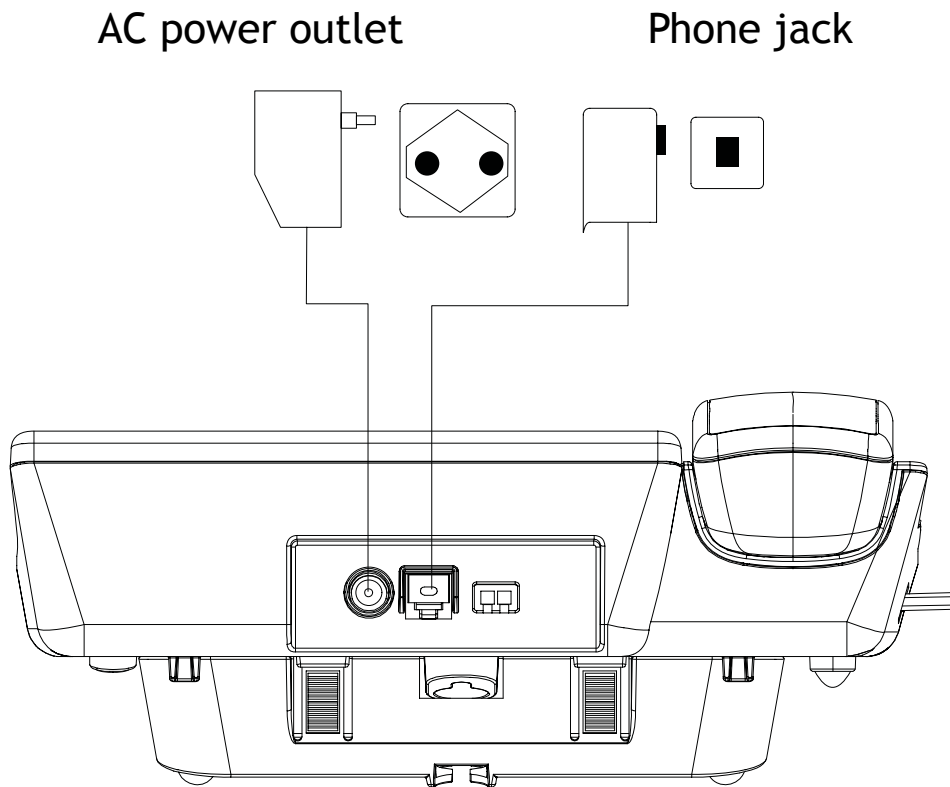

CAUTION:

Plug the adapter to the socket outlet that near the equipment and shall be easily accessible. Use only the Thomson Telecom power supply that came with this unit. Using other power supplies may damage the unit.

Connecting the charging station

Insert the power plug in the socket on the rear side of the charging station. Insert the power plug at the other end in the power outlet. The charging station is now ready to operate.

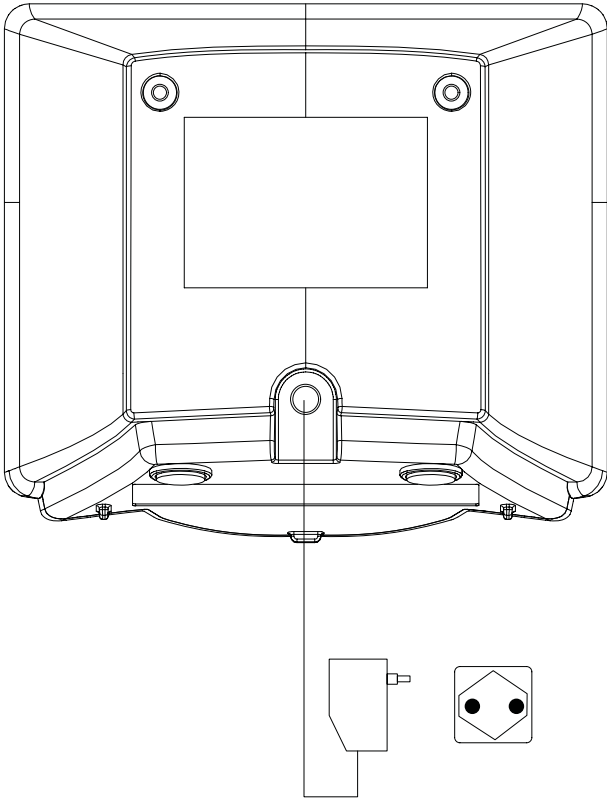

AC power outlet

Getting Started

Install and Charge the Batteries

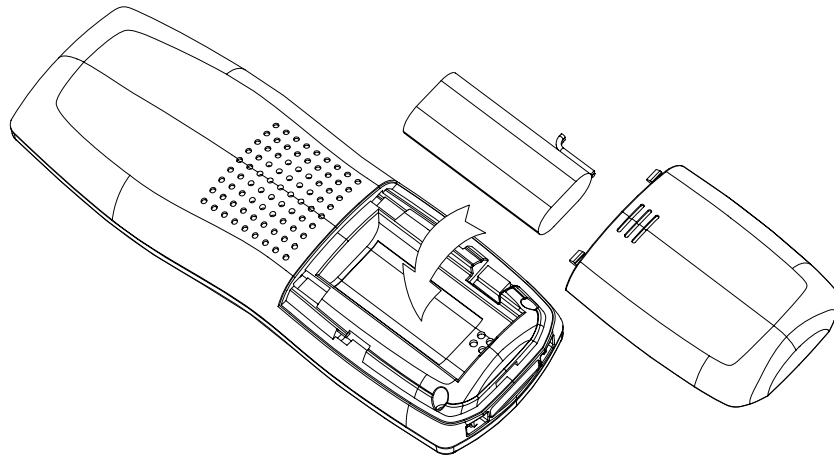

Insert **one AAA battery pack** in the compartment, ensuring correct polarity and close the compartment.

Place the handset in the remote charge unit to charge for 14 hours prior for first use. If you don't properly charge the phone, battery performance will be compromised.

Warning: The handset does not work and damaged if the wrong batteries are inserted.

Use Only Rechargeable batteries supplied (charge at least 14 hours before use).

Do Not use Alkaline or Non Rechargeable batteries.

If batteries are empty, handset LCD will not has any display and the handset will not response to any key. Handset is then required to put back on Base Station / Charger cradle to charge. Handset cannot be used until handset name and aerial icon appear. If handset does not charged full before use, handset may emit battery low alert tone and battery level indicator shows empty.

Corded Base Station Set Up

Ringer Switch Setting

Ringer volume level  /  /  (HIGH/LOW/OFF) can be selected by a switch at the rear side of base station. Default is HI.

Note:

Base intercom ring tone level can't be turn OFF.

Handset ringer volume setting is refer to section of Headset Settings - Ring Volume.

Features

This cordless telephone is equipped with the following features:

Handset Base Station

- Digital sound quality (DECT)
- Large mono display with backlight

- 50 Name and number phone book
- Handsfree
- Caller ID* and Caller ID* with Call Waiting
- Incoming 30 name/number call log
- Multi-language menu.
- 8 level LCD contrast, user changeable
- 10 Last number redial
- Microphone mute
- Conference call+ (1 external with 2 internal)
- Call forwarding/transfer+
- Message waiting indicator*
- Separate base and handset ringers
- 4 Level earpiece volume
- Real time clock display
- Call timer
- Key tone on/off
- Page Handset from base station
- Flash/Pause/Hold function
- Tone and Pulse dialing
- Digital Answering Machine with 12 minutes recording time,59 messages capacity

DECT Cordless Handset

- Large mono display with backlight
- 50 Name and number phone book
- Hands free
- Caller ID * and Caller ID* with Call Waiting
- Incoming 30 name/number call log
- Multi-language menu.
- 5 Ring tone melodies
- Ringer on/off
- 5 level LCD contrast
- 5 level ring volume
- Real time clock display
- Handset naming
- Automatic call answering
- Key input tone on/off
- Battery status inc low battery warning
- Tone and pulse dialing
- Up to 100 hours standby

- Up to 10 hours continuous talk time
- Out of range warning
- Recall/Pause/Hold
- Line in use indication



+ More than one handset required



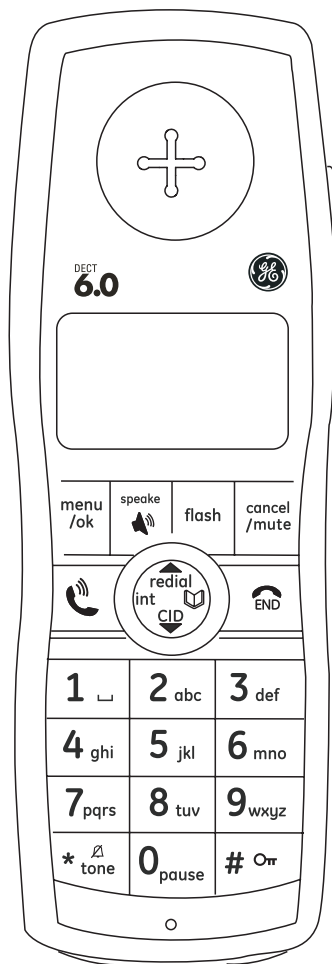

* Subscription may be required. Please contact your network provider.

DECT: Digitally Enhanced Cordless Telecommunication - Standard for Cordless telephones.

Handset Layouts











 redial	Redial / up key
CID 	Caller ID / down key
menu /ok	Menu / OK key

cancel /mute	Cancel / mute key
flash	Flash key
int	Intercom key
	Phone book key
speaker 	Speakerphone key
	Off key
	Talk key
*  tone	Asterisk / ring off / temporary tone dialing key
•	Hash key/Keypad lock key
pause	Pause key

Handset LCD Display





	Speakerphone icon
	Phone icon
	Key lock icon
	Mute icon
	Ring off icon
	Battery icon

	Aerial icon
	Internal call
NEW	Missed call icon
RPT	Repeated call icon
AM	AM icon
PM	PM icon

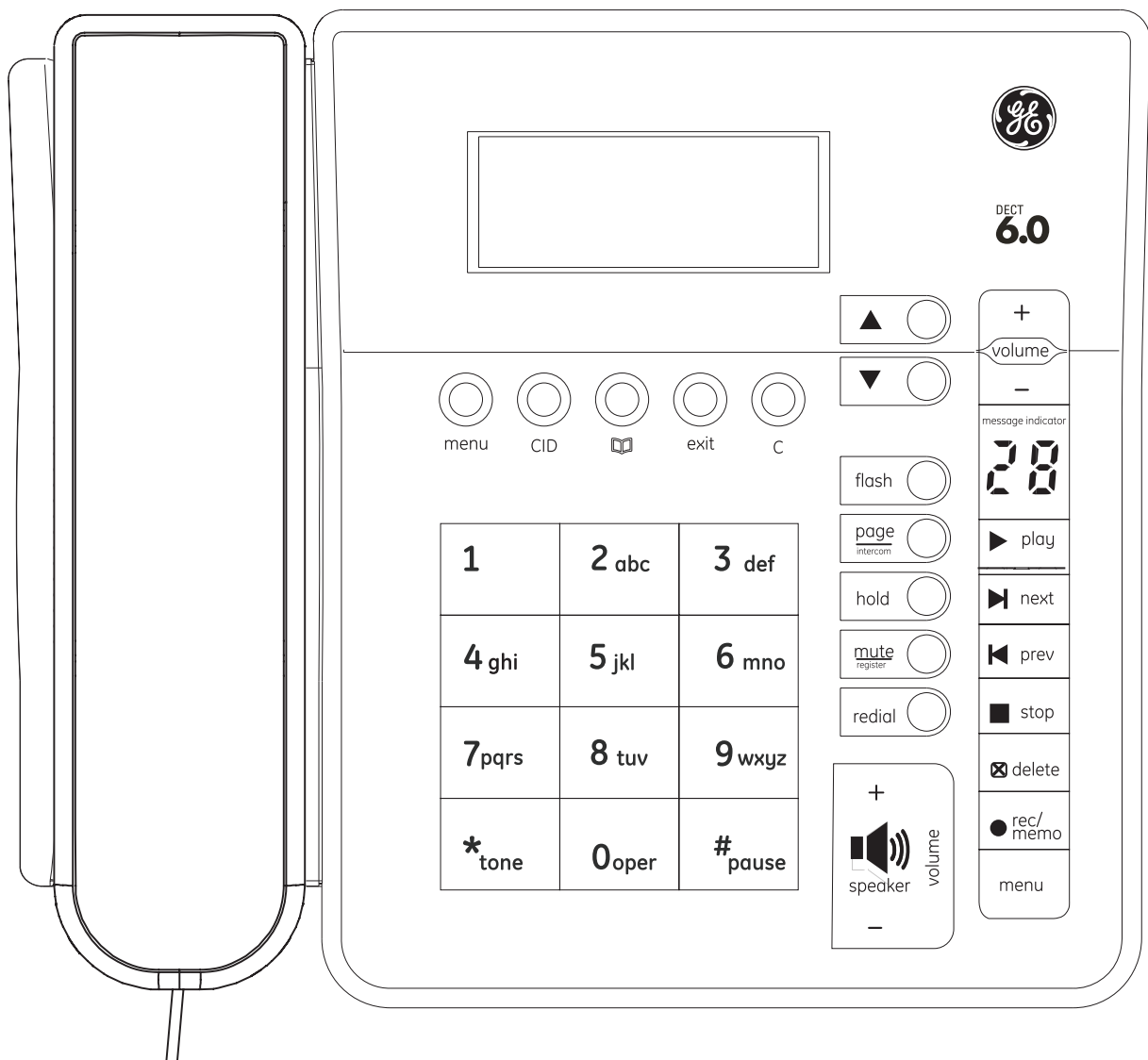

Corded Base Layouts



menu	Menu / OK key
▲ / ▼	Up / down key
C	Cancel key
exit	Exit key





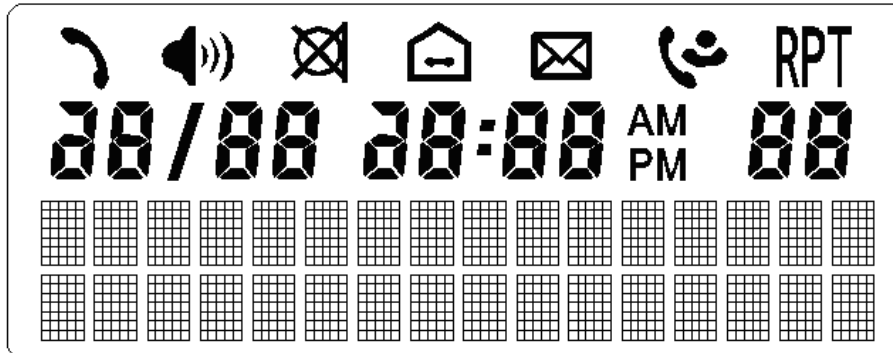

CID	Caller ID key
redial	Redial key
page intercom	Intercom/page key
	Phone book key
hold	Hold key
flash	Flash key
mute register	Mute / register key
	Speaker key
Vol+ / vol-	Volume up / down key
# pause	Hash key / Pause key
*/tone	Asterisk / temporary tone dialing key

Answer Machine

MENU	Menu key
VOL+	Volume up
VOL-	Volume down
 next	Next key
 play	Play key
 stop	Stop key
 prev	Replay/previous key
 delete	Delete key
 rec memo	Record/Memo key

Base LCD



	Phone icon
	Speakerphone icon
	Mute icon
	Internal call icon
	Missed call icon
	(Voice) Message Waiting icon
RPT	Repeated call icon
AM	AM icon
PM	PM icon

Menu Operation

Base menu

Selecting the Language

Different languages display are available for selection.

- Press **menu** key.
- “Language” is displayed and press **menu** key.
- Press **▲** or **▼** key to select the desired language.
- Press **menu** key to confirm the setting.
- Press the exit key to return to idle mode.

Area Code

- Press **menu** key.
- Press ▲ or ▼ key to select “Area Code” and press **menu** key.
- ENTER the area code.
- Press **menu** key to confirm the setting.
- Press the exit key to return to idle mode.

LCD Contrast

There are 8 levels selection. **The default setting is level 4.**

- Press **menu** key.
- Press ▲ or ▼ key to select “CONTRAST” and press **menu** key.
- Press ▲ or ▼ key to select the desired contrast level.
- Press **menu** key to confirm the setting.
- Press the exit key to return to idle mode.

Key Tone

You can set the Base key tone to “On” or “Off” when you press the base keypad. The default setting is “On”.

- Press **menu** key.
- Press ▲ or ▼ key to select “KEY TONE” and press **menu** key.
- Press ▲ or ▼ key to select “ON” or “OFF”.
- Press **menu** key to confirm the setting.
- Press the exit key to return to idle mode.

Dial Mode

You can set the dial mode to “Tone” or “Pulse”. The default setting is “Tone”.

- Press **menu** key.
- Press ▲ or ▼ key to select “DIAL MODE” and press **menu** key.
- Press ▲ or ▼ key to select “TONE” or “PULSE”.
- Press **menu** key to confirm the setting.
- Press the exit key to return to idle mode.

Date / Time

You can set the Date/Time displayed in idle mode. The default setting is **“2007, 01/01 12:01 pm”**.

- Press **menu** key.
- Press ▲ or ▼ key to select “DATE/TIME” and press **menu** key, the LCD will display “Year 2007”.
- Input the correct last two digits of year (range: 00-99) using

number key, press **menu** key to confirm the setting and enter month and date setting.

- Input the correct date and month by numeric key, the format is: month/date (month range: 01-12, date range: 01-30/31) using number key, press **menu** key to confirm the setting and enter time setting.
- Input the correct time, the format is: hour/minute (hour range: 01-12 and 00-23, minute range: 00-59) using number key, and set the “am” or “pm” using ▲ or ▼ key.
- Press **menu** key to confirm the setting.
- Press the exit key to return to idle mode.

Note: If the value you input is over the range, you can't enter next setting by pressing **menu** key, please enter the correct setting again.

Message Waiting

If you have subscribed to a voice messaging service, the  icon will be displayed to alert you if you have a new messages waiting.

You can turn Visual Message Waiting Indication (VMWI) off

- Press the **menu** key.
- Use the ▲ or ▼ keys to scroll to 'VMWI' and press the **menu** key again.
- You will be prompted 'VMWI OFF?' .
- Press the **menu** to confirm the setting.
- Press the exit key to return to idle mode.

Note: This service need subscription to local operator and it supports the FSK CLI system only.

Reset

You can reset your Telephone Base to its original (default) settings.

Note: After reset the base, all the caller ID records stored in base and cordless handset, and all the phonebook and redial records stored in base will be cleared. Please write down the useful information before reset.

- Press **menu** key.
- Press ▲ or ▼ key to select “RESET” and press **menu** key, the LCD will display “ENTER PIN”. (The default setting is “0000”)
- Input the correct PIN code using number key, press **menu** key to confirm, and the LCD will display “RESET?”.
- Press **menu** key to confirm the setting.
- Press the exit key to return to idle mode.

Handset Menu

Handset Setting

Ring Melody

5 ringer tones are available for selection. The default setting is “Melody 1”.

- Press MENU/OK key.
- Press ▲ or ▼ key to select SETUP HS and press MENU/OK key.
- Press ▲ or ▼ key to select RING MELODY and press MENU/OK key.
- Press ▲ or ▼ key to select the desired ring melody, the selected melody is sounded.
- Press MENU/OK key to confirm.
- Press the  key to return to idle mode.

Ring Volume

5 ring volumes are available for selection. The default setting is volume 5. Ringer can be disabled by pressing * key for 1.5 seconds in idle mode, and then  icon will then shown on the display. Press and hold * key again can Enable ringer again.

- Press MENU/OK key.
- Press ▲ or ▼ key to select SETUP HS and press MENU/OK key.
- Press ▲ or ▼ key to select RING VOLUME and press MENU/OK key.
- Press ▲ or ▼ key to select the desired ring volume, the selected volume is sounded.
- Press MENU/OK key to confirm.
- Press the  key to return to idle mode.

Note: For the cordless handset, the intercom ring volume can't be adjusted, but it can be turned off.

Low Battery

You can set the warning beep to ON when cordless handset battery is low. It alert you to charge the battery. The default setting is ON.

- Press MENU/OK key.
- Press ▲ or ▼ key to select “SETUP HS” and press MENU/OK key.
- Press ▲ or ▼ key to select TONES and press MENU/OK key.

- Press ▲ or ▼ key to select LOW BATTERY and press MENU/OK key.
- Press ▲ or ▼ key to select ON or OFF.
- Press MENU/OK key to confirm.
- Press the  key to return to idle mode.

No Coverage

You can set the warning beep to ON or OFF when the cordless handset is out of range. The default setting is **ON**.

- Press MENU/OK key.
- Press ▲ or ▼ key to select SETUP HS and press MENU/OK key.
- Press ▲ or ▼ key to select TONES and press MENU/OK key.
- Press ▲ or ▼ key to select NO COVERAGE and press MENU/OK key.
- Press ▲ or ▼ key to select ON or OFF.
- Press MENU/OK key to confirm.
- Press the  key to return to idle mode.

Key Tone

You can set the key tone to ON or OFF.. The default setting is ON.

- Press MENU/OK key.
- Press ▲ or ▼ key to select SETUP HS and press MENU/OK key.
- Press ▲ or ▼ key to select TONES and press MENU/OK key.
- Press ▲ or ▼ key to select KEY TONE and press MENU/OK key.
- Press ▲ or ▼ key to select ON or OFF.
- Press MENU/OK key to confirm.
- Press the  key to return to idle mode.

Auto Talk

This option allows user to pick up the cordless handset from charger to answer the call directly during ringing, and no need to press  or speaker

-  key. The default setting is ON.
- Press MENU/OK key.
- Press ▲ or ▼ key to select SETUP HS and press MENU/OK key.
- Press ▲ or ▼ key to select AUTO TALK and press MENU/OK key.
- Press ▲ or ▼ key to select ON or OFF.

- Press MENU/OK key to confirm.
- Press the  key to return to idle mode.

(Daily) Alarm

- Press MENU/OK key.
- Press ▲ or ▼ key to select SETUP HS and press MENU/OK key.
- Press ▲ or ▼ key to select ALARM and press MENU/OK key.
- Press ▲ or ▼ key to select ON or OFF.
- Enter HH:MM
- Handset Name Press MENU/OK key to confirm.

Note: 1. “A” is shown on display.

2. When Alarm time is reached, “ALARM ON” will blinking and alarm sound will stop after around 1 minute.

Name

You can set the cordless handset name that you like. The default name is HANDSET.

- Press MENU/OK key.
- Press ▲ or ▼ key to select SETUP HS and press MENU/OK key.
- Press ▲ or ▼ key to select HANDSET NAME and press MENU/OK key.
- Edit the desired name by pressing number key. (delete incorrect cancel entries by pressing /mute key).
- Press MENU/OK key to confirm.
- Press the  key to return to idle mode.

Note: Press ▲ or ▼ key can move the cursor.

Language

Your cordless handset has different display language, the name of each language setting is always spelt in its own language.

- Press MENU/OK key.
- Press ▲ or ▼ key to select SETUP HS and press MENU/OK key.
- Press ▲ or ▼ key to select LANGUAGE and press MENU/OK key.
- Press ▲ or ▼ key to select the desired language.
- Press MENU/OK key to confirm the setting.
- Press the  key to return to idle mode.

LCD Contrast

There are 5 levels selection. **The default setting is level 3.**

- Press MENU/OK key.
- Press ▲ or ▼ key to select SETUP HS and press MENU/OK key.
- Press ▲ or ▼ key to select CONTRAST and press MENU/OK key.
- Press ▲ or ▼ key to select the desired contrast level.
- Press MENU/OK key to confirm.
- Press the  key to return to idle mode.

Reset Handset

You can reset your cordless handset to its original (default) settings.

- Press MENU/OK key.
- Press ▲ or ▼ key to select SETUP HS and press MENU/OK key.
- Press ▲ or ▼ key to select RESET and press MENU/OK key, the LCD will display “RESET?”
- Press MENU/OK key to confirm the setting.
- Press the  key to return to idle mode.

Base Setting

Change PIN

PIN is your base’s identification number, this function is to avoid the stored setting is changed by others. The default setting is “0000”. Please take down the new PIN code for your record.

- Press MENU/OK key.
- Press ▲ or ▼ key to select SETUP BS and press MENU/OK key.
- Press ▲ or ▼ key to select CHANGE PIN and press MENU/OK key, the LCD will show ENTER PIN (default setting = 0000).
- Press number key to input the current PIN code and press MENU/OK key, the LCD will show NEW PIN, prompt you to input a new PIN code.

Note: WRONG PIN will be shown if the current PIN code you input is wrong, and then return to step 4.

- Input the desired new PIN code and press MENU/OK key, the LCD will show REPEAT PIN, prompt you to input the new PIN code again.
- Input the new PIN code again and press MENU/OK key to confirm the setting.

- Press the  key to return to idle mode.

Note: 1. The PIN code must be 4 digits.

2. If the new PIN code that you input two times is different, the change will fail, the display will return to step 5. (prompt you to input new PIN code)

Dial Mode

You can set the dial mode to TONE or PULSE. The default setting is TONE.

- Press MENU/OK key.
- Press ▲ or ▼ key to select SETUP BS and press MENU/OK key.
- Press ▲ or ▼ key to select DIAL MODE and press MENU/OK key.
- Press ▲ or ▼ key to select TONE or PULSE.
- Press MENU/OK key to confirm the setting.
- Press the  key to return to idle mode.

Message Waiting (VMWI)

If you have subscribed to a voice message waiting service, MESSAGE WAITING will be displayed on handset and  icon in Base will turn ON if you have a messages waiting call.

You can reset Visual Message Waiting Indication (VMWI) to Off by the Cordless Handset

- Press the MENU/OK key.
- Press ▲ or ▼ key to select SETUP BS and press MENU/OK key.
- Press ▲ or ▼ key to select VMWI and press MENU/OK key.
- You will be prompted 'VMWI OFF?'
- Press the MENU/OK to confirm.
- Press the  key to return to idle mode.

Note: This service need subscription to local operator and it supports the FSK CLI system only.

Reset Base

This option allows user to restore the base and Date/Time to the default setting.

Note: After reset the base, all the caller ID records stored in base and cordless handset, and all the phonebook and redial records stored in base will be cleared. Please write down the useful information before reset.

- Press MENU/OK key.
- Press ▲ or ▼ key to select SETUP BS and press MENU/OK key.
- Press ▲ or ▼ key to select RESET and press MENU/OK key, the LCD will display ENTER PIN (default setting = 0000).
- Input the correct PIN code by pressing numeric key, press MENU/OK key to confirm, and the LCD will display “RESET?”
- Press MENU/OK key to confirm.
- Press the  key to return to idle mode.

Date / Time

You can set the Date/Time displayed in idle mode. The default setting is “2007, 01/01 12:01 pm”.

- Press MENU/OK key.
- Press ▲ or ▼ key to select DATE/TIME and press MENU/OK key, the LCD will display “YEAR 2007”.
- Input the correct last two digits of year (range: 00-99) using number key, press MENU/OK key to confirm and then enter month and date setting.
- Input the correct date and month by numeric key, the format is: month/date (month range: 01-12, date range: 01-30/31) using number key, press MENU/OK key to confirm the setting and enter time setting.
- Input the correct time by numeric key,, the format is: hour/minute (hour range: 01-12 and 00-23, minute range: 00-59), and set the “am” or “pm” by pressing ▲ or ▼ key.
- Press MENU/OK key to confirm.
- Press the  key to return to idle mode.

Note: If the figure you input is over the range, you can’t enter next setting menu even pressing MENU/OK key, you are required to enter the correct setting again.

Registration

Register

Up to 4 cordless handsets can be registered to one base.

- Press MENU/OK key.
- Press ▲ or ▼ key to select REGISTRATION and press MENU/OK key.
- Press ▲ or ▼ key to select REGISTER and press MENU/OK key,

- the LCD will display ENTER PIN (default setting = 0000).
- Input the correct PIN code and press MENU/OK key to begin to register the cordless handset, the LCD will display SEARCHING.
- Press and hold the mute
register key on base around 6 seconds until the base LCD show REGISTRATION.
- After Registered, press the  key to quit

(during “SEARCHING” is displayed, handset can’t quit until time out) .

Note: 1. SUCCESSFUL will be shown on cordless handset if it is registered to the base. Cordless handset number eg.2 will be shown after it returns to idle mode.

2. NO BASE will be shown on cordless handset if it can’t register to the base within 1 minute, you have to register the handset again.

3. If the PIN code you input is wrong, registration will not succeed. Handset will display “WRONG PIN” after time out.

Remove Handset

This function allows user to remove the registered cordless handset from the base.

- Press MENU/OK key.
- Press ▲ or ▼ key to select REGISTRATION and press MENU/OK key.
- Press ▲ or ▼ key to select REMOVE HANDSET and press MENU/OK key, the LCD will display ENTER PIN.(default setting = 0000).
- Input the correct PIN code and press MENU/OK key.
- Press ▲ or ▼ key to select the cordless handset (1,2,3,4) you want to remove and press MENU/OK key, the LCD will display “REMOVE HANDSET?”
- Press MENU/OK key to confirm the setting.
- Press the  key to return to idle mode.

Note: 1. The removed cordless handset LCD will show “NOT REG”. You must register it again before using it.

2. If the PIN code you input is wrong, “WRONG PIN” will be shown on cordless handset LCD.

Basic Operation

Making External Calls

Pre-dialing



Post-dialling Using the Base

- Pick up the corded handset from the base or press  key,
- Dial the desired telephone number.

Note: When the base is used, the handset will display “LINE IN USE”.

- Hang up the corded handset or press  key to end the call. The call timer will be shown and last for about 2 seconds before return to idle mode.

Post-dialling Using the Cordless Handset

- Press the  or  key, wait for a dial tone, and then dial the desired telephone number.
- Press  key or place the cordless handset into the charger to end the call.

The call timer will be shown and last for about 2 seconds before return to idle mode.





Pre-dialing

Pre-dialing Using the Base

- Input the desired telephone number.
- Delete any incorrect digit by pressing **C** key.
- Pick up the corded handset from the base or press  key, the number will be automatically dialled out.

- Hang up the corded handset or press  key to end the call. The call timer will be shown and last for about 2 seconds before return to idle mode.

Pre-dialling Using the Cordless Handset

- Input the desired telephone number.
- Delete any incorrect digit by pressing  /mute key.
- Press the  or  key, the number will be automatically dialled out.
- Press  key or place the cordless handset into the charger to end the call.

The call timer will be shown and last for about 2 seconds before return to idle mode.

Adjust the Receiver or Speaker Volume

You can adjust the receiver or speaker volume during a call (external or internal). There are 5 different volume levels



During a call:

- Press the Volume VOL + or VOL - key to adjust the volume on corded base.
- Press the Volume ▲ or ▼ key to adjust the volume on cordless handset.

Taking Calls

When the phone rings, the icon  will flash and the LCD on the base and cordless handset will show “Call”.

Take a Call Using the Base

- Pick up the corded handset from the base or press  key to answer a call.
- Hang up the corded handset or press  key to end the call.

Take a Call Using the Cordless Handset

- Take the cordless handset from the charging station, the connection is automatically established (when the AUTO TALK

function is active). Otherwise press  or  .

- Press  key or place the cordless handset into the charger to end the call.

Hands-free

Switch between Speakerphone & Receiver Using the Base

To switch to speakerphone mode, press  key and hang up the corded handset.

To switch to receiver mode, pick up the corded handset from the base.

Switch between Speakerphone & Receiver Using the Cordless Handset

To switch to speakerphone mode, press  key.



To switch to receiver mode, press  key again or press  key.

Making Internal Calls

You can make internal calls between base and cordless handset, or any two cordless handsets (if you have more than one cordless handset).

Base to Cordless Handset

- When base is in idle mode, **press intercom key**, “INT-NUMBER?” will be shown, input the cordless handset number. (1,2,3,4) you want to call.
- The called cordless handset will ring and the LCD will show “Base”.

- Press  or  key of the called cordless handset to answer.

Cordless Handset to Base

- When the cordless handset is in idle mode, press **int** key,

- “INT-NUMBER?” will be shown, input the number “0”.
- The base will ring and the LCD will show the calling cordless handset’s name and number.





- Pick up the corded handset or press  key from the base to answer.

Cordless Handset to Cordless Handset

- When the cordless handset is in idle mode, press **int** key, “INT-NUMBER?” will be shown, input the cordless handset number (1,2,3,4) you want to call..
- The called cordless handset will ring and the LCD will show the calling cordless handset’s name and number.

speaker

- Press  or  key of the called cordless handset to answer.

Call Transfer



The function allows you to transfer an external call from base to a cordless handset, or from a cordless handset to base or another cordless handset.

- During an external call, **press intercom key** on base or **int** key on handset to put the external call on hold.
- Enter the number of the handset that you would like to transfer the call to (0 for base, 1-4 for cordless handset).
- When the paged handset or base answers the call, intercom is established.
- After calling base user or calling handset user hangs up (press , external line is then transferred..

Note: 1. There must be more than two handsets registered to the base, otherwise the call transfer function from one cordless handset to another cordless handset will be invalid;
 2. If the internal call is not answered in 100 seconds after the paging, it will call back external line.

Three Party Conference



After receiving an external call, it is possible to include a second handset in the conversation.

- During an external call, Press  or  key of the called cordless handset to answer (If Base, Pick up the corded handset from the base or press **speaker** key).
- After calling base user or calling handset user hangs up (press ) , The remaining party can continuously connect to the external call.

Redial Function





The last 10 phone numbers you dial out are separately stored in base and cordless handset redial memory. The redial function of the base and cordless handset is the same.

Dial a number from the Redial memory



- Press REDIAL key on base or  redial key on cordless handset. If the redial memory is empty, EMPTY will be shown.
- Press  or  key to select the desired Redial number.
- Take telephone line with the base or cordless handset, the telephone number is automatically dialed out.

Note: If you want to edit the number before dialing out, press MENU/OK key to enter menu and select SELECT to edit the Redial number.

Save Redial Memory

- Press REDIAL key on base or  redial key on cordless handset.
- Press  or  key to select the desired redial number.
- Press MENU/OK key on the base or handset to enter menu, press  or  key to select SAVE NUMBER, press MENU/OK key, ENTER NAME will be shown and you can input the desired name. You must input the name; otherwise the record can't be saved.
- Press MENU/OK key on the base or handset to save.

Delete a Single Redial Memory

- Press REDIAL key on base or  redial key on cordless handset.
- Press  or  key to select the desired redial number.
- Press MENU/OK key on the base or handset to enter menu, press

▲ or ▼ key to select DELETE, press MENU/OK key again, CONFIRM? will be shown.

- Press MENU/OK key on the base or handset to confirm.

Delete All Redial Memory

- Press REDIAL key on base or  key on cordless handset.
- Press MENU/OK key on the base or handset to enter menu, press ▲ or ▼ key to select DELETE ALL, press MENU/OK key again, CONFIRM? will be shown.
- Press MENU/OK key on the base or handset to confirm.

Caller ID Service

The caller's information will be displayed and recorded if you have subscribed to Caller ID service from your local telephone company.

When the telephone rings, the caller's information will be displayed on the base and cordless handset LCD display. This information includes the phone number and name (if supported). The base or cordless handset can store up 30 calls (up to 20 digits and 15 characters for each record). When the memory is full, a new call will automatically replaces the oldest call in the memory.

Note: 1. If the caller's information includes Date/Time, the Date/Time will be stored into the record. The Date/Time display is also updated after receiving a call.

2. If the caller number is matched with one of phonebook memory, the matched name stored in the phonebook memory will be displayed.
3. If the incoming call is registered as "Private Number" and its caller ID information is withheld, LCD will show PRIVATE..
4. If the incoming call does not have Caller ID service or its service area is not linked to yours, the LCD will show UNAVAILABLE.
5. Display "MISSED CALLS" - call is missed or some Caller-ID memories not yet reviewed. Base will also shows the  icon .
6. If the same call are received more than one time, the "RPT" icon will be shown when you review the record to prompt you this is a repeat call.
7. Display "LONG DISTANCE" - Long distance call is received.

Review Caller ID Record

- Press CID key and use ▲ or ▼ key to review all call records.
- If an area code is included in the caller number, you can press the # key to change the caller number display format.

For example:

If the displayed caller number is 123-4567 and your preset local area code is 888, press the # key once will display 888-123-4567. Press # key again will display 1-888-123-4567.

If the displayed caller number is 1-333-123-4567, press the # key once will display 333-123-4567. Press # key again will display 123-4567.

Dial from Call Log

- Press CID key and use ▲ or ▼ key to select the desired record.

- Lift the corded handset or press  on the handset base or  on the cordless handset.

press the  key or  key on the cordless handset.

Note: If you want to edit the number before dialing out, press MENU/OK key to enter menu and select SELECT to edit the number.

Store Call Log into Phonebook

- Press CID key and use ▲ or ▼ key to select the desired record.
- Press MENU/OK key.
- Press ▲ or ▼ key to select SAVE NUMBER.
- Press MENU/OK key and use the numeric keypad to enter a name

cancel
for the phone book entry. press the /mute on the cordless handset or C key on the corded base to delete any incorrect entries.

To enter the characters for a name, press the numeric key consecutively eg: letter H, press the number 4 key twice. If 2 consecutive characters are on the same key, enter the first character, then wait for the cursor to move to the right before entering the next character.

- Press the MENU/OK key to save the entry.

Key Assignment Overview

Key	Capital letter
1	1 space € £ \$ % & <>
2	A B C 2 Ä Å Á Â Ã Ä Æ Ç À Ā Ć Ć
3	D E F 3 È É Ê Ë Ì Đ Ď Ě Ě
4	G H I 4 Ğ Ĩ Í Î Ï
5	J K L 5 Ł
6	M N O 6 Ö Ò Ó Ô Õ Ø Ñ Ñ Ñ Ó
7	P Q R S 7 ß Ş P Ř Š Š
8	T U V 8 Ü Ù Ú Û Ť Ů Ů
9	W X Y Z 9 Ý Ÿ Ž Ž Ž
0	. , ? ! 0 + - : ' " Δ ¿
#	# * @ \ / _ () = \$

Delete a Single Call Log



- Press CID key and use ▲ or ▼ key to select the desired record.
- Press MENU/OK key.
- Press ▲ or ▼ key to select DELETE.
- Press MENU/OK key, the LCD will show CONFIRM?, press MENU/OK key again to confirm.

Delete All Call Records

- Press CID key.
- Press MENU/OK key.
- Press ▲ or ▼ key to select DELETE ALL.
- Press MENU/OK key, the LCD will show CONFIRM?, press MENU/OK key again to confirm.

Caller ID Dial Back

When browsing Call Log memory, you can pick up the base corded handset or press the base speaker key or press the cordless handset speaker

 key or  key to dial back directly to the Caller Line Identification (CLI) number on the LCD.



Advanced Operation

Phonebook

Your corded base and cordless handset can each store up to 50 names and numbers, Each Phonebook memory can be up to 15 characters and 24 digits long.

Note: You can also view the Phonebook during a call



Review Phonebook

- Press  key on the cordless handset or  key on the corded base.

Note: If the phonebook is empty PHONEBOOK EMPTY will be shown.

- Press ▲ or ▼ key to review phonebook memories.
- You can search a name by inputting the first character.
- Review the phone number in accordance with the name by pressing * key.
- When you scroll to the end, “-----” will be shown.

Store Name and Number into Phonebook



- Press  key on the cordless handset or  key on the corded base.
- Press MENU/OK key to enter menu, select ADD NEW.
- Press MENU/OK key
- ENTER NUMBER will be shown, enter number using the keypad. Press and hold 0 key if a PAUSE is needed, character “P” will be shown.
- Press MENU/OK key.
- ENTER NAME will be shown, enter the name by pressing the keypad. If you need to delete any incorrect characters, press
cancel
the /mute on the cordless handset or C key on the corded base.

To enter the characters for a name, press the numeric key consecutively eg: letter H you would press the number 4 key twice. If 2 consecutive characters are on the same key, enter the first character, then wait for the cursor to move to the right before entering the next character.

- Press MENU/OK key to save the record.



Note: When MEMORY FULL is shown, you must delete one or more unnecessary records before saving a new record.

Edit Phonebook Memory



- Press  key on the cordless handset or  key on the corded base and use ▲ or ▼ key to select the desired record.
- Press MENU/OK key.
- Press ▲ or ▼ key to select EDIT and press MENU/OK key.
- Use the keypad to edit the number entry (press ▲ or ▼ key to move the cursor).
- Press MENU/OK key.
- Use the keypad to edit the name entry (press ▲ or ▼ key to move cursor).
- Press MENU/OK key to save the entry.

Note: Delete a digit at left side of cursor, press ^{cancel}/mute on cordless handset or C key on corded base.

Delete Phonebook Memory

- Press  key on the cordless handset or  key on the corded base and use ▲ or ▼ key to select the desired record.
- Press MENU/OK key.
- Press ▲ or ▼ key to select DELETE.
- Press MENU/OK key, the LCD will show CONFIRM? , Press MENU/OK key again to confirm.

Dial Record from Phonebook

- Press  key on the cordless handset or  key on the corded base and use ▲ or ▼ key to select the desired record
- Take telephone line with the base or cordless handset, the telephone number is automatically dialed out.

Note: If you want to edit the number before dialing out, press MENU/OK key to enter menu and select SELECT to edit the

number first.

Special Feature

Page All Cordless Handsets from Base

- Press and hold $\frac{\text{page}}{\text{intercom}}$ key on the base for 3 seconds, the base LCD will show PAGING HANDSETS, all the cordless handset will beep and LCD show PAGING.
- Press EXIT or C key on the base or press any key on the cordless handset to stop. Paging sound will be stopped **after 30 seconds**.

Temporary Tone (for pulse or rotary service user)

In pulse dialing mode, you can switch to Tone dialing to access bank facilities etc. by pressing * key.

It will reset automatically to pulse dialing after you end the call.

Mute

- Press MUTE key on base or $\frac{\text{cancel}}{\text{mute}}$ on cordless handset to active the mute feature during talking.
- The mute icon  will be shown.
- Press MUTE key on base or $\frac{\text{cancel}}{\text{mute}}$ on cordless handset again to turn it off.

Pause

You can insert a 3 seconds PAUSE into the dialing or storing of a number into phonebook.

E.g. to dial number: 9 + PAUSE (press and hold 0 key on handset or $\frac{\#}{\text{pause}}$ on base) + telephone number.

Press and hold 0 key on handset or $\frac{\#}{\text{pause}}$ on base for 1.5 seconds, the LCD will show "P".

Flash

Use FLASH key on corded base or flash key on cordless handset to activate custom calling services such as call waiting or call forwarding,



which are available through your local telephone company. “R” will be shown on the LCD.

The FLASH key or R key can also be used to access a new dial tone without hanging up.

Note: Refer section of Base Setting - Flash Time to select Flash duration. If the function dial did not work normally, please contact with the vendor of the PBX or your local telephone company.

Keypad Lock (only for cordless handset)

The default setting is “Off”.

- To lock the keypad, press and hold **#** ^{om} key until a beep is heard during standby,  icon will be shown.
- To unlock the keypad, press and hold # key again until a beep is heard and  icon is disappear.

Note: When the key lock is activated, you can still be able to accept incoming calls.

Hold Call (only for base)

The line will be hold by pressing HOLD key, a music will be heard as a reminder.



Lift the corded handset or press  key or press HOLD key again to release the Hold function. The hold can also be released when the branch phone answer the call.

Answering machine system Menu and programming

In idle mode, you can program each of the following options:

Turn Answering System On/Off

Set the Day and Time

Record your outgoing Announcement

Set your Remote Access code

Set ‘Announce Only’ On/Off

Turn audible Message Alert On/Off

Set Base ringer On/Off

Set number of Rings to answer

Set Answering Machine ON/OFF

When you first switch on your phone, the answering machine is in the ON mode.

1. Press Menu key. When you hear the announcement, press ◀ prev or ▶ next to switch between the On/Off setting.
2. Press Menu key to confirm your setting.

Set CLOCK

1. Press Menu key repeatedly until you reach Clock setting option.
2. Press ◀ prev or ▶ next key to program the Day. As you program, the display shows ' d' and a number, 1 to 7, representing the day of the week 1 represents Monday; 2 represents Tuesday, and so on. Press Menu key to confirm.
3. Press ◀ prev or ▶ next key to program the Hour. Be careful that you program pm hour if the current time is in the afternoon or evening, or an am hour if the current time is after midnight or in the morning. Press Menu key to confirm.
4. Press ◀ prev or ▶ next key to program the Minute. You'll be programming the 'tens' column first. Your choices are 0 through 5, as the minutes range from 00 to 59. Press Menu. Now, you are programming the 'ones' column, where your choices are 0 through 9. Press Menu key to confirm.

Note: If the mains power to the base is lost, your answer machine will display "St." (Set time) to remind you adjust the clock when it is switch on.

Outgoing Announcement

You can record 2 different outgoing announcements: A 1 inviting your caller to leave a message (Announce Only OFF), and A 2 asking your caller to call back later (AnnounceOnly ON).

Outgoing Announcement A 1 is played when Announce Only mode is OFF. Callers can leave a message in this mode. Your answering machine is preset with Announce Only set to OFF, allowing callers to leave a message.

Outgoing Announcement A 2 is played when Announce Only mode is ON. Callers cannot leave a message in this mode.

If you do not record your own announcements, your answering system will play a pre-programmed message to your callers:

A1: "Please leave your message after the beep."

A2: "I am sorry I am not available. Please call back later."

Record an Answering Announcement

Make sure the announce only is set to OFF.

1. Press "Menu" button repeatedly until you hear "Announcement One"
2. Press "●^{rec} memo" button. You will hear 'Now Recording' followed by a beep. Speak toward the Base Unit. You have up to 60 seconds for your announcement. Your announcement must be at least 3 seconds in length.
3. Press "■ stop" button when finished. Your recording will be played automatically. If you're not satisfied, record your announcement again.

Record an Answer Only Announcement

Make sure the announce only is set to ON.

1. Press "Menu" button repeatedly until you hear "Announcement Two"
2. Press "●^{rec} memo" button. You will hear 'Now Recording' followed by a beep. Speak toward the Base Unit. You have up to 60 seconds for your announcement. Your announcement must be at least 3 seconds in length.
3. Press "■ stop" button when finished. Your recording will be played automatically. If you're not satisfied, record your announcement again.

To Review/Delete Your Announcement A1/A2

1. Press **MENU** until you hear 'Announcement One' (Announce Only set to OFF) or 'Announcement Two' (Announce Only set to ON).
2. Press Play, you will hear the announcement of A1 or A2 (you can

only review the latest recorded announcement).

3. During playing the announcement of A1 or A2, press DEL to delete the current announcement and the answering machine will use the default announcement.

Note: The default announcement cannot be deleted.

Set remote access code

Your remote access code helps prevent unauthorized people from ringing up your answering machine and listening to your messages. The code can be any 4-digit number, from 0000 to 9999.

1. Press Menu button repeatedly until you hear "Remote access code is..." and the display shows Ac.
2. Press ◀ prev or ▶ next to set the first digit between 0-9. Press Menu to confirm.
3. Repeat Step 2 until all 4 digits have been set. The machine announces the new code. (The pre-set code is 0000.)

Remote Operation

You can access many features of this DAM remotely from a touch-tone phone.

- 1 When the unit is connected to the telephone line. During the announcement, Enter your remote access code (default 0000).
- 2 If the code entered is correct, it will give one beep.
- 3 If remote code entered is wrong, the DAM cannot enter remote control mode. The DAM allows user to enter 16 digits maximum. If it still cannot match the 4 digits, the unit will release the line. If the user presses wrongly, the user needs to enter the whole remote code again.
- 4 Within 5 seconds, enter a remote command (see "remote access commands") else it will play the help menu automatically. After finished the help menu playback, if there is no command input within 20 seconds, the unit will release the line.
- 5 The DAM has voice prompts to help you to do remote operation. When you enter Remote Control State, then press '* ' to hear the voice menu while remotely connected to the DAM.
- 6 The DAM will pause after the message replay for 165 seconds. The playback will stop if don't press any key on the remote telephone within 20 seconds, then the DAM release the line.

- 7 Notice that during remote message playback, the unit will not be stopped when remote telephone hanged up. The playback will continue up to end of playback.)
And During Remote Control State, if pickup the parallel phone to take the line, the unit should exit remote control within 5 seconds.

Your Remote Access function allows you to retrieve messages, and record memos and announcements when you're away from your Answering Machine.

1. Call your answering machine from any touch-tone phone.
2. When you hear your outgoing announcement, enter your 4-digit Remote Access code. .
3. You can now perform the following functions:
 - Press two to play messages
 - Press two to stop
 - Press zero to delete current message
 - Press one to repeat current message or previous message
 - Press three to play next message
 - Press four to toggle machine on or off
 - Press seven for help
4. After selecting each digit press Menu to confirm.

Set 'Announce Only' On / Off

1. Press Menu key repeatedly until you hear “announce only is on or off”.
2. Press ◀ prev or ▶ next to switch between the On/Off setting. (preset to Off)
3. Press **Menu** key to confirm your setting.

Set Audible Message Alert On / Off

When Message Alert is ON, the Base unit will beep once every 10 seconds when new messages have been received.

1. Press Menu key repeatedly until you hear “message alert is on or off”.
2. Press ◀ prev or ▶ next to switch between the On/Off setting. (preset to Off)
3. Press Menu key to confirm your setting.

Set Base Ringer On / Off

Your Base Ringer is independent of the Handset ringer.

1. Press Menu key repeatedly until you hear “base ringer is on or off”.
2. Press ◀ prev or ▶ next to switch between the On/Off setting. (preset to Off)
3. Press Menu key to confirm your setting.

Set Number of Rings to Answer

Your Answering System can answer after 2 -6 rings or you can choose the Toll Saver option. The Toll saver option instructs the Answering System to answer after 4 rings only if there are new, un-played messages; otherwise, it will answer after 6 rings. The benefit to you is if you are making a long distance call to retrieve messages, if the Answering System does not answer after 4 rings, you can hang up. There are no new messages, and you will save the expense of a long distance call.

1. Press Menu key repeatedly until you hear “number of rings selected is 2/3/4/5/6/toll saver”.
2. Press ▶ next to choose your desired section. (preset to toll saver)
3. Press Menu key to confirm your setting.

Recording a Memo

You can record a memo, either at the Base Unit or from a remote location. To record a Memo at the Base:

1. Press and hold **MEMO** .
2. You will hear ' Please speak after the tone ', followed by a beep.
3. Speak towards the Base Unit. Release **MEMO** when finished. Your memo is stored like a message from an outside caller.

To record a memo from a remote location, follow instructions in the Remote Operation section.

Note: If memory is full while recording, the answering machine will announce "memory is full ", at the same time the 7-segments LED will display "F" and the message count alternatively.

Listen to your Messages

When you have new messages, the message counter will flash, showing the number of unplayed messages.

When you have new messages, the appropriate MAILBOX (es) will flash. If a Mailbox only contains old messages, the indicator will glow steadily.

Recorded messages and memos are retained until you delete them.

Your Answering System has approximately 12 minutes of storage capacity (or 59 messages/memos). If its capacity is full, the system will answer after 10 rings, and the caller will hear 'Memory is Full '.

Play messages

When you have new messages, the message counter will flash, showing the number of unplayed messages.

When you have new messages, the indicator will flash. If the Mailbox only contains old messages, the indicator will glow steadily.

Recorded messages and memos are retained until you delete them.

Your Answering System has approximately 12 minutes of storage capacity (or 59 messages/memos). If its capacity is full, the system will answer after 10 rings, and the caller will hear ' Memory is Full '.

Message Playback

1. Press the  play key. The prompt will tell you how many new and old messages are stored in that Mailbox. If there are one or more new messages, only the new messages will be played. After new message playback is completed, you can press the Play key again to hear all old messages.

Note: If short press the  play key, the order of playback is oldest messages first, newest last.

Before each message is played, the day and time it was recorded is announced.

2. Press  to skip to the next message.

3. Press  stop at any time to end playback.

Deleting Messages

To delete the message or memo currently playing, press  delete.
To delete all old messages stored in the Mailbox:

1. In the idle mode, press and hold  delete. You will hear "All old Messages are Deleted"

2. All old messages will be deleted.

NOTE: New, unplayed messages cannot be deleted until you play them.
Once you deleted the message ,it cannot be recovered.

Important information

There is a total of 12 minutes of record time. This includes messages, memos, and announcements.

The maximum number of messages that can be stored is 59.

A message, memo, or announcement can be a maximum of 2 minutes.
If a call comes in while you are listening to messages, playback automatically stops.

Troubleshooting Guide

When you forgot the base PIN code, follow the following procedures can RESET the PIN code to "0000".

1. with the base is in standby mode, press MENU/OK key and key in "442737"
2. Press ▲ or ▼key, "FACTORY RESET" is shown.
3. Press MEN/OK key, "RESET" is shown
4. Press MENU/OK to confirm.
5. Press the exit key on base to quit.
6. Following "Registration" section to register all handsets again.

PROBLEMS	CAUSES	SOLUTIONS
Registration not work.	The battery is not sufficiently charged. Handset and base station were not prepared for	Charge the battery for 14 hours (see Battery Charging). Unplug and then plug in the power adaptor.

	<p>registration.</p> <p>Wrong PIN code is entered</p>	<p>Enter correct PIN code again. (default is 0000)</p>
No display.	The battery has not been charged.	Charge the battery or replace them (see Battery Charging)
<p>No reactions to keystroke.</p> <p>No radio connection to the base station: blinking!</p>	<p>The keypad is locked.</p> <p>The handset is outside the base station range.</p> <p>The handset is not registered.</p> <p>The base station does not work.</p>	<p>Press # key longer than 2 seconds.</p> <p>Move closer to the base station.</p> <p>Register the handset (see Registering Handset).</p> <p>Unplug and then plug the power adaptor to the power outlet (120V AC / 60 Hz) and the other end into the power jack on base bottom.</p>
Base or cordless handset displays "NOT AVAILABLE"	<p>The handset is outside the base station range</p> <p>The base station does not work.</p> <p>Either cordless handset or base is in use.</p>	<p>Move closer to the base station.</p> <p>Unplug and then plug the power adaptor to the power outlet (120V AC / 60 Hz) and the other end into the power jack on base bottom.</p> <p>Wait for cordless handset or base return idle state.</p>

--	--	--

General Product Care

To keep your unit working and looking good, follow these guidelines:

- Avoid dropping the handset, as well as other rough treatment to the phone.
- Wipe the base station with a damp cloth or an antistatic wipe. Never use a dry cloth as this can cause static discharge.
- Retain the original packaging in case you need to ship the phone at a later date.
- Periodically clean the charge contacts on the handset and remote charger with a clean pencil eraser.

Causes of Poor Reception

- Aluminum siding.
- Foil backing on insulation.
- Heating ducts and other metal construction that can shield radio signals.
- You're too close to appliances such as microwaves, stoves, televisions, entertainment centers, etc.
- Atmospheric conditions, such as strong storms.
- Base is installed in the basement or lower floor of the house.
- Base is plugged into AC outlet with other electronic devices.
- Handset battery is low.

Accessory Information

DESCRIPTION	MODEL NO.
DC power adapter for base unit	5-2823
DC power adaptor for handset charge cradle	5-2824

To place order, have your Visa, MasterCard, or Discover Card ready and call toll-free 1-800-338-0376. A shipping and handling fee will be charged upon ordering. We are required by law to collect appropriate sales tax for each individual state, country, and locality to which the merchandise is being sent. Items are subject to availability.

Service

If trouble is experienced with this equipment, for repair or warranty information, please contact customer service at 1-800-448-0329. If the equipment is causing harm to the telephone network, the telephone company may request that you disconnect the equipment until the problem is resolved.

This product may be serviced only by the manufacturer or its authorized service agents. Changes or modifications not expressly approved by Thomson Inc. could void the user's authority to operate this product. For instructions on how to obtain service, refer to the warranty included in this guide or call customer service at 1-800-448-0329.

Or refer inquiries to:

Thomson Inc.
Manager, Consumer Relations
PO Box 1976
Indianapolis, IN 46206-1976

Attach your sales receipt to the booklet for future reference or jot down the date this product was purchased or received as a gift. This information will be valuable if service should be required during the warranty period.

Purchase date

Name of store

Limited Warranty

What your warranty covers:

- Defects in materials or workmanship.

For how long after your purchase:

- One year, from date of purchase.

(The warranty period for rental units begins with the first rental or 45 days from date of shipment to the rental firm, whichever comes first.)

What we will do:

- Provide you with a new or, at our option, a refurbished unit. The exchange unit is under warranty for the remainder of the original product's warranty period.

How you get service:

- Properly pack your unit. Include any cables, etc., which were originally provided with the product. We recommend using the original carton and packing materials.
- "Proof of purchase in the form of a bill of sale or receipted invoice which is evidence that the product is within the warranty period, must be presented to obtain warranty service." For rental firms, proof of first rental is also required. Also print your name and address and a description of the defect. Send via standard UPS or its equivalent to:

Thomson Inc.
11721 B Alameda Ave.
Socorro, Texas 79927

- Pay any charges billed to you by the Exchange Center for service not covered by the warranty.
- Insure your shipment for loss or damage. Thomson Inc. accepts no liability in case of damage or loss.
- A new or refurbished unit will be shipped to you freight prepaid.

What your warranty does not cover:

- Customer instruction. (Your User's Guide provides information regarding operating instructions and user controls. Any additional information, should be obtained from your dealer.)
- Installation and setup service adjustments.
- Batteries.
- Damage from misuse or neglect.

- Products which have been modified or incorporated into other products.
- Products purchased or serviced outside the USA.
- Acts of nature, such as but not limited to lightning damage.

Product Registration:

- Please complete and mail the Product Registration Card packed with your unit. It will make it easier to contact you should it ever be necessary. The return of the card is not required for warranty coverage.

Limitation of Warranty:

- The warranty stated above is the only warranty applicable to this product. All other warranties, express or implied (including all implied warranties of merchantability or fitness for a particular purpose) are hereby disclaimed. No verbal or written information given by Thomson Inc., its agents, or employees shall create a guaranty or in any way increase the scope of this warranty.
- Repair or replacement as provided under this warranty is the exclusive remedy of the consumer. Thomson Inc. shall not be liable for incidental or consequential damages resulting from the use of this product or arising out of any breach of any express or implied warranty on this product. This disclaimer of warranties and limited warranty are governed by the laws of the state of Indiana. Except to the extent prohibited by applicable law, any implied warranty of merchantability or fitness for a particular purpose on this product is limited to the applicable warranty period set forth above.

How state law relates to this warranty:

- Some states do not allow the exclusion nor limitation of incidental or consequential damages, or limitations on how long an implied warranty lasts so the above limitations or exclusions may not apply to you.
- This warranty gives you specific legal rights, and you also may have other rights that vary from state to state.

If you purchased your product outside the USA:

- This warranty does not apply. Contact your dealer for warranty information.

28861(draft)

Digital Cordless Telephone and
Corded Speakerphone with Dual
Mode Caller ID User's Guide

.

Equipment Approval Information

Your telephone equipment is approved for connection to the Public Switched Telephone Network and is in compliance with parts 15 and 68, FCC Rules and Regulations and the Technical Requirements for Telephone Terminal Equipment published by ACTA.

1 Notification to the Local Telephone Company

On the bottom of this equipment is a label indicating, among other information, the US number and Ringer Equivalence Number (REN) for the equipment. You must, upon request, provide this information to your telephone company.

The REN is useful in determining the number of devices you may connect to your telephone line and still have all of these devices ring when your telephone number is called. In most (but not all) areas, the sum of the RENs of all devices connected to one line should not exceed 5. To be certain of the number of devices you may connect to your line as determined by the REN, you should contact your local telephone company.

A plug and jack used to connect this equipment to the premises wiring and telephone network must comply with the applicable FCC Part 68 rules and requirements adopted by the ACTA. A compliant telephone cord and modular plug is provided with this product. It is designed to be connected to a compatible modular jack that is also compliant. See installation instructions for details.

Notes

- This equipment may not be used on coin service provided by the telephone company.
- Party lines are subject to state tariffs, and therefore, you may not be able to use your own telephone equipment if you are on a party line. Check with your local telephone company.
- Notice must be given to the telephone company upon permanent disconnection of your telephone from your line.
- If your home has specially wired alarm equipment connected to the telephone line, ensure the installation of this product does not disable your alarm equipment. If you have questions about what will disable alarm equipment, consult your telephone company or a qualified installer.

US Number is located on the cabinet bottom.

REN Number is located on the cabinet bottom.

2 Rights of the Telephone Company

Should your equipment cause trouble on your line which may harm the telephone network, the telephone company shall, where practicable, notify you that temporary discontinuance of service may be required. Where prior notice is not practicable and the circumstances warrant such action, the telephone company may temporarily discontinue service immediately. In case of such temporary discontinuance, the telephone company must: (1) promptly notify you of such temporary discontinuance; (2) afford you the opportunity to correct the situation; and (3) inform you of your right to bring a complaint to the Commission pursuant to procedures set forth in Subpart E of Part 68, FCC Rules and Regulations. The telephone company may make changes in its communications facilities, equipment, operations or procedures where such action is required in the operation of its business and not inconsistent with FCC Rules and Regulations. If these changes are expected to affect the use or performance of your telephone equipment, the telephone company must give you adequate notice, in writing, to allow you to maintain uninterrupted service.

Interference Information

This device complies with Part 15 of the FCC Rules. Operation is subject to the following two conditions: (1) This device may not cause harmful interference; and (2) This device must accept any interference received, including interference that may cause undesired operation.

This equipment has been tested and found to comply with the limits for a Class B digital device, pursuant to Part 15 of the FCC Rules. These limits are designed to provide reasonable protection against harmful interference in a residential installation.

This equipment generates, uses, and can radiate radio frequency energy and, if not installed and used in accordance with the instructions, may cause harmful interference to radio communications. However, there is no guarantee that interference will not occur in a particular installation.

Privacy of Communications may not be ensured when using this

product.

If this equipment does cause harmful interference to radio or television reception, which can be determined by turning the equipment off and on, the user is encouraged to try to correct the interference by one or more of the following measures:

- Reorient or relocate the receiving antenna (that is, the antenna for radio or television that is “receiving” the interference).
- Reorient or relocate and increase the separation between the telecommunications equipment and receiving antenna.
- Connect the telecommunications equipment into an outlet on a circuit different from that to which the receiving antenna is connected.

If these measures do not eliminate the interference, please consult your dealer or an experienced radio/television technician for additional suggestions. Also, the Federal Communications Commission has prepared a helpful booklet, “How To Identify and Resolve Radio/TV Interference Problems.” This booklet is available from the U.S. Government Printing Office, Washington, D.C. 040. Please specify stock number 004-000-00345-4 when ordering copies.

Notice: The changes or modifications not expressly approved by the party responsible for compliance could void the user's authority to operate the equipment.

Hearing Aid Compatibility (HAC)

This telephone system meets FCC standards for Hearing Aid Compatibility.

Licensing

Licensed under US Patent 6,427,009.

FCC RF Radiation Exposure Statement

This equipment complies with FCC RF radiation exposure limits set forth for an uncontrolled environment. This equipment should be installed and operated with a minimum distance of 20 centimeters between the radiator and your body. This transmitter must not be

co-located or operated in conjunction with any other antenna or transmitter.”

For body worn operation, this phone has been tested and meets the FCC RF exposure guidelines when used with the belt clip supplied with this product. Use of other accessories may not ensure compliance with FCC RF exposure guidelines.

Information for DECT Product



This telephone is compliant with the DECT 6.0 standard which operates in the 1.92GHz to 1.93GHz frequency range.

Battery Safety Precautions

- Do not burn, disassemble, mutilate, or puncture. Like other batteries of this type, toxic materials could be released which can cause injury.
- To reduce the risk of fire or personal injury, use only the battery listed in User’s Guide.
- Keep batteries out of children.
- Remove batteries if storing over 30 days.
- Do Not Use Alkaline or Non Rechargeable Batteries.



CAUTION:

Danger of explosion if battery is incorrectly replaced. Replace only with **5-2826 2.4V 600mAh** rechargeable battery or equivalent. Only use rechargeable batteries with exactly the same specifications as those supplied with the product. Using non-rechargeable or non-conforming batteries can damage the product. The batteries could split or leak if incorrectly inserted, opened or exposed to heat. Never dispose of batteries in a fire: the cell could explode. Check with local code for possible special disposal instruction.

Note: To ensure the battery charging properly, clean the charging contacts on the handset and charger with a soft, dry cloth once a

month. Clean more often if the unit is subject to grease, dust or high humidity.

Installation

Packaging Contents

Packaging contents	Single pack	Twin pack	Triple pack
Handset Base Stations	1	1	1
Cordless Handset	1	2	3
Mains Adaptor	2	3	4
Telephone Line Cord	1	1	1
Batteries, type AAA, 2.4V 600mAh”	1	2	3
Charging station	1	2	3
Operating instructions	1	1	1

Please check the contents of the package carefully. If anything is missing or shows signs of transport damage, do NOT put the telephone into service! In such a case, contact either your sales outlet with the purchase receipt.

Connecting the Base Station and Power Plug

Connecting the plugs to the corresponding sockets in the base station (they can not be connected incorrectly because the sockets and plugs are designed prevent reverse poling). Plug the telephone line in the telephone connection socket. Insert the power plug at the other end in

the power outlet. The base station is now ready to operate.

Only use the connection cable supplied.

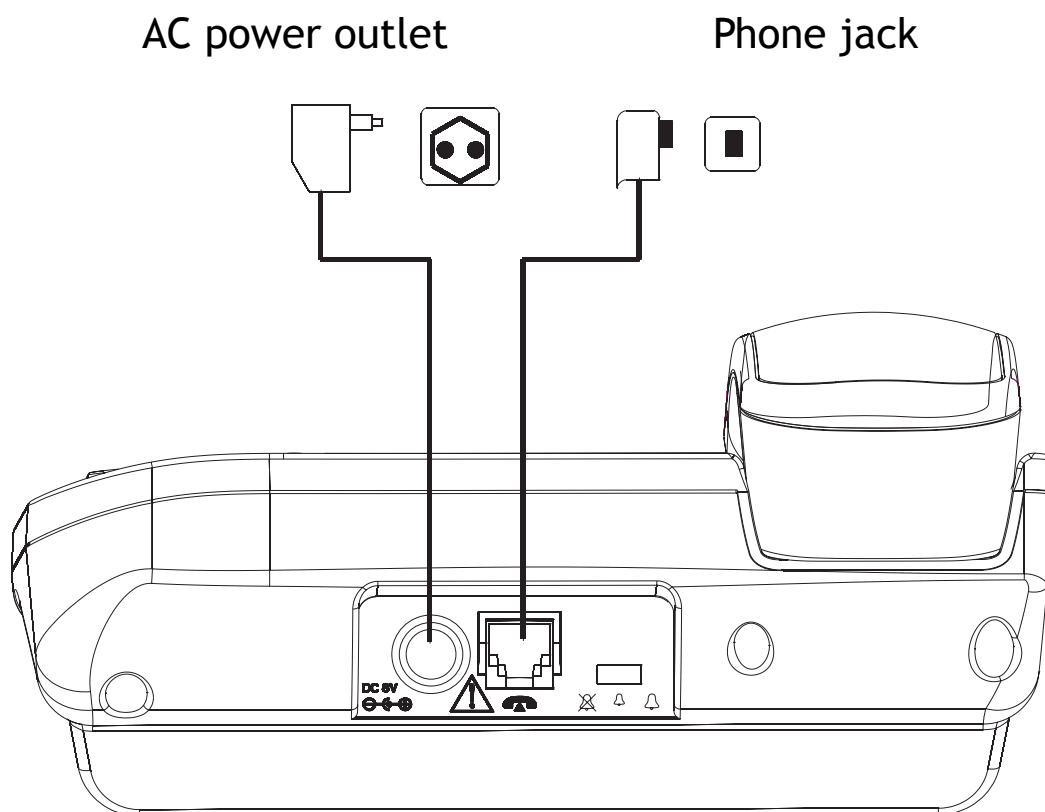

CAUTION:

Plug the adapter to the socket outlet that near the equipment and shall be easily accessible. Use only the Thomson Telecom power supply that came with this unit. Using other power supplies may damage the unit.

Connecting the charging station

Insert the power plug in the socket on the rear side of the charging station. Insert the power plug at the other end in the power outlet. The charging station is now ready to operate.

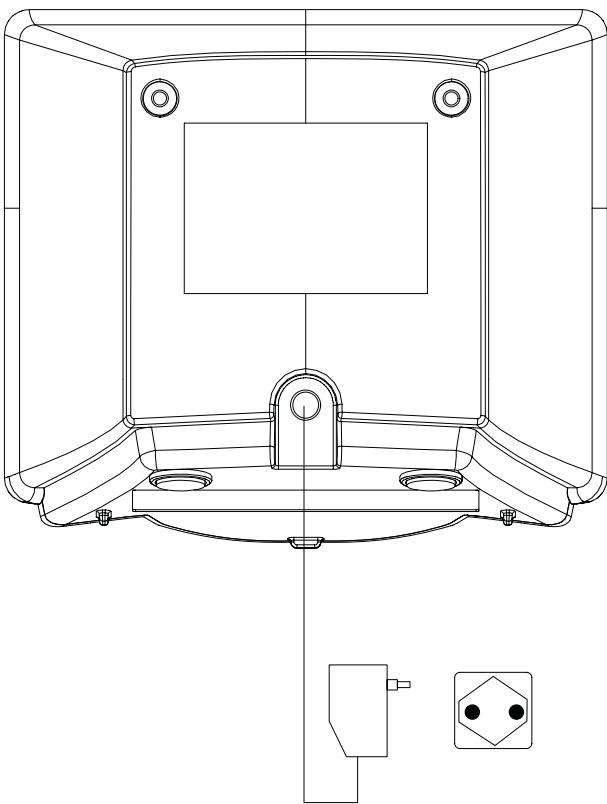

AC power outlet

Getting Started

Install and Charge the Batteries

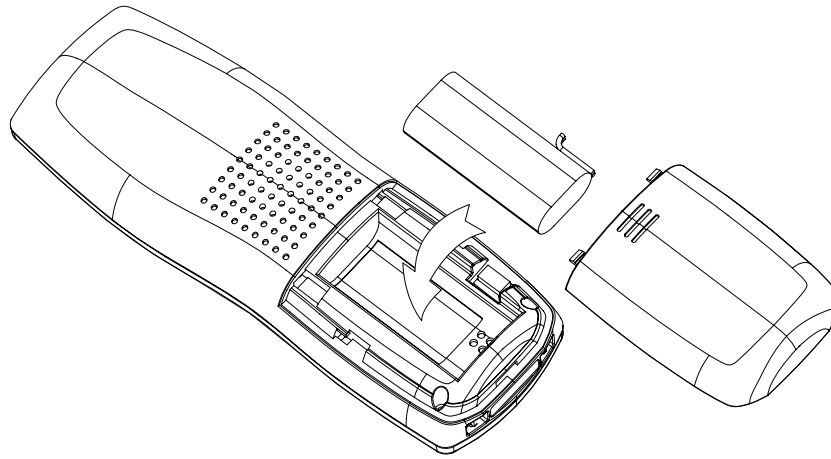

Insert **one AAA battery pack** in the compartment, ensuring correct polarity and close the compartment.

Place the handset in the remote charge unit to charge for 14 hours prior for first use. If you don't properly charge the phone, battery performance will be compromised.

Warning: The handset does not work and damaged if the wrong batteries are inserted.

Use Only Rechargeable batteries supplied (charge at least 14 hours before use).

Do Not use Alkaline or Non Rechargeable batteries.

If batteries are empty, handset LCD will not has any display and the handset will not response to any key. Handset is then required to put back on Base Station / Charger cradle to charge. Handset cannot be used until handset name and aerial icon appear. If handset does not charged full before use, handset may emit battery low alert tone and battery level indicator shows empty.

Corded Base Station Set Up

Ringer Switch Setting

Ringer volume level // (HIGH/LOW/OFF) can be selected by a switch at the rear side of base station. Default is HI.

Note: Base intercom ring tone level can't be turn OFF. Handset ringer volume setting is refer to section of Headset Settings - Ring Volume.

Features

This cordless telephone is equipped with the following features:

Handset Base Station

- Digital sound quality (DECT)
- Large mono display with backlight
- 50 Name and number phone book
- Handsfree
- Caller ID* and Caller ID* with Call Waiting
- Incoming 30 name/number call log
- Multi-language menu.
- 8 level LCD contrast, user changeable
- 10 Last number redial
- Microphone mute
- Conference call+ (1 external with 2 internal)
- Call forwarding/transfer+
- Message waiting indicator*
- Separate base and handset ringers
- 4 Level earpiece volume
- Real time clock display
- Call timer
- Key tone on/off
- Page Handset from base station
- Flash/Pause/Hold function
- Tone and Pulse dialing

DECT Cordless Handset

- Large mono display with backlight
- 50 Name and number phone book
- Hands free
- Caller ID * and Caller ID* with Call Waiting
- Incoming 30 name/number call log
- Multi-language menu.
- 5 Ring tone melodies
- Ringer on/off
- 5 level LCD contrast
- 5 level ring volume
- Real time clock display
- Handset naming

- Automatic call answering
- Key input tone on/off
- Battery status inc low battery warning
- Tone and pulse dialing
- Up to 100 hours standby
- Up to 10 hours continuous talk time
- Out of range warning
- Recall/Pause/Hold
- Line in use indication





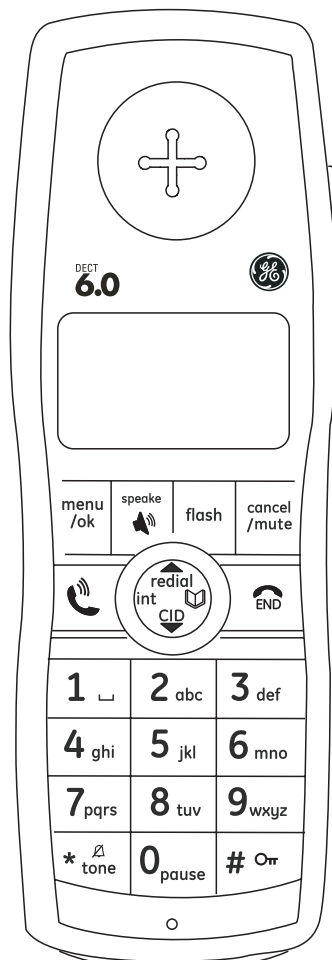

+ More than one handset required

* Subscription may be required. Please contact your network provider.

DECT: Digitally Enhanced Cordless Telecommunication - Standard for Cordless telephones





Handset Layouts







 redial	Redial / up key
 CID	Caller ID / down key
menu /ok	Menu / OK key
cancel /mute	Cancel / mute key
flash	Flash key
int	Intercom key
	Phone book key
speaker 	Speakerphone key
	Off key
	Talk key
*  tone	Asterisk / ring off / temporary tone dialing key
•	Hash key/Keypad lock key
pause	Pause key

Handset LCD Display



	Speakerphone icon
	Phone icon
	Key lock icon
	Mute icon

	Ring off icon
	Battery icon
	Aerial icon
	Internal call
NEW	Missed call icon
RPT	Repeated call icon
AM	AM icon
PM	PM icon



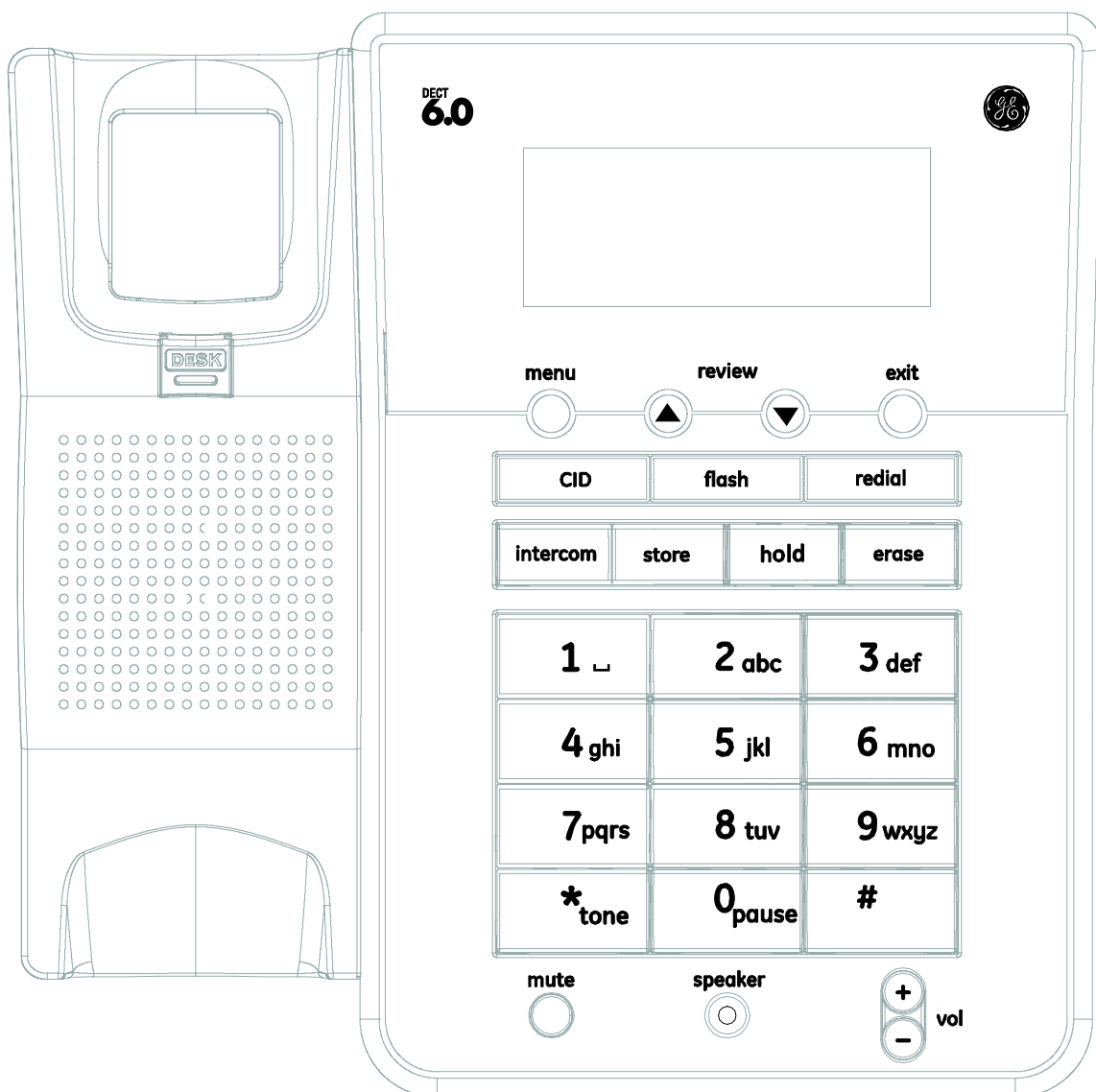

Corded Base Layouts

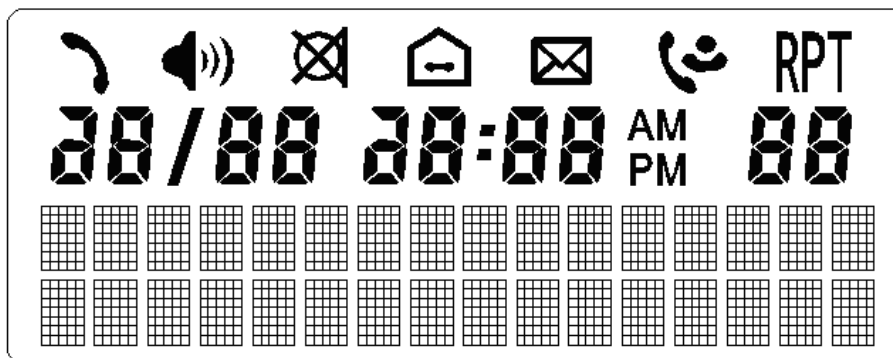

menu	Menu / OK key
▲ / ▼	Up / down key
erase	Cancel key
exit	Exit key
CID	Caller ID key
redial	Redial key
intercom	Intercom/ page key
store	Phone book key
hold	Hold key
flash	Flash key
mute	Mute key
speaker	Speaker key
Vol+ / vol-	Volume up / down key
0 pause	Pause key
*/tone	Asterisk / temporary tone dialing key

Base LCD



	Phone icon
	Speakerphone icon
	Mute icon
	Internal call icon
	Missed call icon

	(Voice) Message Waiting icon
RPT	Repeated call icon
AM	AM icon
PM	PM icon

Menu Operation

Base menu

Selecting the Language

Different languages display are available for selection.

- Press **menu** key.
- “Language” is displayed and press **menu** key.
- Press ▲ or ▼ key to select the desired language.
- Press **menu** key to confirm the setting.
- Press the exit key to return to idle mode.

Area Code

- Press **menu** key.
- Press ▲ or ▼ key to select “Area Code” and press **menu** key.
- ENTER the area code.
- Press **menu** key to confirm the setting.
- Press the exit key to return to idle mode.

LCD Contrast

There are 8 levels selection. **The default setting is level 4.**

- Press **menu** key.
- Press ▲ or ▼ key to select “CONTRAST” and press **menu** key.
- Press ▲ or ▼ key to select the desired contrast level.
- Press **menu** key to confirm the setting.
- Press the exit key to return to idle mode.

Key Tone

You can set the Base key tone to “On” or “Off” when you press the base keypad. The default setting is “On”.

- Press **menu** key.
- Press ▲ or ▼ key to select “KEY TONE” and press **menu** key.
- Press ▲ or ▼ key to select “ON” or “OFF”.
- Press **menu** key to confirm the setting.
- Press the exit key to return to idle mode.

Dial Mode

You can set the dial mode to “Tone” or “Pulse”. The default setting is “Tone”.

- Press **menu** key.
- Press ▲ or ▼ key to select “DIAL MODE” and press **menu** key.
- Press ▲ or ▼ key to select “TONE” or “PULSE”.
- Press **menu** key to confirm the setting.
- Press the exit key to return to idle mode.

Date / Time

You can set the Date/Time displayed in idle mode. The default setting is “2007, 01/01 12:01 pm”.

- Press **menu** key.
- Press ▲ or ▼ key to select “DATE/TIME” and press **menu** key, the LCD will display “Year 2007”.
- Input the correct last two digits of year (range: 00-99) using number key, press **menu** key to confirm the setting and enter month and date setting.
- Input the correct date and month by numeric key, the format is: date/month (date range: 01-30/31, month range: 01-12) using number key, press **menu** key to confirm the setting and enter time setting.
- Input the correct time, the format is: hour/minute (hour range: 01-12 and 00-23, minute range: 00-59) using number key, and set the “am” or “pm” using ▲ or ▼ key.
- Press **menu** key to confirm the setting.
- Press the exit key to return to idle mode.

Note: If the value you input is over the range, you can't enter next setting by pressing **menu** key, please enter the correct setting again.

Message Waiting

If you have subscribed to a voice messaging service, the  icon will be displayed to alert you if you have a new messages waiting.

You can turn Visual Message Waiting Indication (VMWI) off

- Press the **menu** key
- Use the ▲ or ▼ keys to scroll to 'VMWI' and press the **menu** key again
- You will be prompted 'VMWI OFF?'
- Press the **menu** to confirm the setting.
- Press the exit key to return to idle mode.

Note: This service need subscription to local operator and it supports the FSK CLI system only.

Reset

You can reset your Telephone Base to its original (default) settings.

Note: After reset the base, all the caller ID records stored in base and cordless handset, and all the phonebook and redial records stored in base will be cleared. Please write down the useful information before reset.

- Press **menu** key.
- Press ▲ or ▼ key to select "RESET" and press **menu** key, the LCD will display "ENTER PIN". (The default setting is "0000")
- Input the correct PIN code using number key, press **menu** key to confirm, and the LCD will display "RESET?".
- Press **menu** key to confirm the setting.
- Press the exit key to return to idle mode.

Handset Menu

Handset Setting

Ring Melody

5 ringer tones are available for selection. The default setting is "Melody 1".

- Press MENU/OK key.
- Press ▲ or ▼ key to select SETUP HS and press MENU/OK key.
- Press ▲ or ▼ key to select RING MELODY and press MENU/OK

key.

- Press ▲ or ▼ key to select the desired ring melody, the selected melody is sounded.
- Press MENU/OK key to confirm.
- Press the  key to return to idle mode.

Ring Volume

5 ring volumes are available for selection. The default setting is volume 5. Ringer can be disabled by pressing * key for 1.5 seconds in idle mode, and then  icon will then shown on the display. Press and hold * key again can Enable ringer again.

- Press MENU/OK key.
- Press ▲ or ▼ key to select SETUP HS and press MENU/OK key.
- Press ▲ or ▼ key to select RING VOLUME and press MENU/OK key.
- Press ▲ or ▼ key to select the desired ring volume, the selected volume is sounded.
- Press MENU/OK key to confirm.
- Press the  key to return to idle mode.

Note: For the cordless handset, the intercom ring volume can't be adjusted, but it can be turned off.

Low Battery

You can set the warning beep to ON when cordless handset battery is low. It alert you to charge the battery. The default setting is ON.

- Press MENU/OK key.
- Press ▲ or ▼ key to select “SETUP HS” and press MENU/OK key.
- Press ▲ or ▼ key to select TONES and press MENU/OK key.
- Press ▲ or ▼ key to select LOW BATTERY and press MENU/OK key.
- Press ▲ or ▼ key to select ON or OFF.
- Press MENU/OK key to confirm.
- Press the  key to return to idle mode.

No Coverage

You can set the warning beep to ON or OFF when the cordless handset

is out of range. The default setting is **ON**.

- Press MENU/OK key.
- Press ▲ or ▼ key to select SETUP HS and press MENU/OK key.
- Press ▲ or ▼ key to select TONES and press MENU/OK key.
- Press ▲ or ▼ key to select NO COVERAGE and press MENU/OK key.
- Press ▲ or ▼ key to select ON or OFF.
- Press MENU/OK key to confirm.
- Press the  key to return to idle mode.

Key Tone

You can set the key tone to ON or OFF.. The default setting is ON.

- Press MENU/OK key.
- Press ▲ or ▼ key to select SETUP HS and press MENU/OK key.
- Press ▲ or ▼ key to select TONES and press MENU/OK key.
- Press ▲ or ▼ key to select KEY TONE and press MENU/OK key.
- Press ▲ or ▼ key to select ON or OFF.
- Press MENU/OK key to confirm.
- Press the  key to return to idle mode.

Auto Talk

This option allows user to pick up the cordless handset from charger to answer the call directly during ringing, and no need to press  or speaker



key. The default setting is ON.

- Press MENU/OK key.
- Press ▲ or ▼ key to select SETUP HS and press MENU/OK key.
- Press ▲ or ▼ key to select AUTO TALK and press MENU/OK key.
- Press ▲ or ▼ key to select ON or OFF.
- Press MENU/OK key to confirm.
- Press the  key to return to idle mode.

(Daily) Alarm

- Press MENU/OK key.
- Press ▲ or ▼ key to select SETUP HS and press MENU/OK key.
- Press ▲ or ▼ key to select ALARM and press MENU/OK key.

- Press ▲ or ▼ key to select ON or OFF.
- Enter HH:MM
- Press MENU/OK key to confirm.

Note: 1. “A” is shown on display.

2. When Alarm time is reached, “ALARM ON” will be blinking and alarm sound will stop after around 1 minute.

Handset Name

You can set the cordless handset name that you like. The default name is HANDSET.

- Press MENU/OK key.
- Press ▲ or ▼ key to select SETUP HS and press MENU/OK key.
- Press ▲ or ▼ key to select HANDSET NAME and press MENU/OK key.
- Edit the desired name by pressing number key. (delete incorrect entries by pressing **erase** key).
- Press MENU/OK key to confirm.
- Press the  key to return to idle mode.

Note: Press ▲ or ▼ key can move the cursor.

Language

Your cordless handset has different display language, the name of each language setting is always spelt in its own language.

- Press MENU/OK key.
- Press ▲ or ▼ key to select SETUP HS and press MENU/OK key.
- Press ▲ or ▼ key to select LANGUAGE and press MENU/OK key.
- Press ▲ or ▼ key to select the desired language.
- Press MENU/OK key to confirm the setting.
- Press the  key to return to idle mode.

LCD Contrast

There are 5 levels selection. **The default setting is level 3.**

- Press MENU/OK key.
- Press ▲ or ▼ key to select SETUP HS and press MENU/OK key.
- Press ▲ or ▼ key to select CONTRAST and press MENU/OK key.
- Press ▲ or ▼ key to select the desired contrast level.
- Press MENU/OK key to confirm.

- Press the  key to return to idle mode.

Reset Handset

You can reset your cordless handset to its original (default) settings.

- Press MENU/OK key.
- Press ▲ or ▼ key to select SETUP HS and press MENU/OK key.
- Press ▲ or ▼ key to select RESET and press MENU/OK key, the LCD will display “RESET?”
- Press MENU/OK key to confirm the setting.
- Press the  key to return to idle mode.

Base Setting

Change PIN

PIN is your base’s identification number, this function is to avoid the stored setting is changed by others. The default setting is “0000”. Please take down the new PIN code for your record.

- Press MENU/OK key.
- Press ▲ or ▼ key to select SETUP BS and press MENU/OK key.
- Press ▲ or ▼ key to select CHANGE PIN and press MENU/OK key, the LCD will show ENTER PIN (default setting = 0000).
- Press number key to input the current PIN code and press MENU/OK key, the LCD will show NEW PIN, prompt you to input a new PIN code.

Note: WRONG PIN will be shown if the current PIN code you input is wrong, and then return to step 4.

- Input the desired new PIN code and press MENU/OK key, the LCD will show REPEAT PIN, prompt you to input the new PIN code again.
- Input the new PIN code again and press MENU/OK key to confirm the setting.
- Press the  key to return to idle mode.

Note: 1. The PIN code must be 4 digits.

2. If the new PIN code that you input two times is different, the change will fail, the display will return to step 5. (prompt you to input new PIN code)

Dial Mode

You can set the dial mode to TONE or PULSE. The default setting is TONE.

- Press MENU/OK key.
- Press ▲ or ▼ key to select SETUP BS and press MENU/OK key.
- Press ▲ or ▼ key to select DIAL MODE and press MENU/OK key.
- Press ▲ or ▼ key to select TONE or PULSE.
- Press MENU/OK key to confirm the setting.
- Press the  key to return to idle mode.

Message Waiting (VMWI)

If you have subscribed to a voice message waiting service, MESSAGE WAITING will be displayed on handset and  icon in Base will turn ON if you have a messages waiting call.

You can reset Visual Message Waiting Indication (VMWI) to Off by the Cordless Handset

- Press the MENU/OK key.
- Press ▲ or ▼ key to select SETUP BS and press MENU/OK key.
- Press ▲ or ▼ key to select VMWI and press MENU/OK key.
- You will be prompted 'VMWI OFF?'
- Press the MENU/OK to confirm.
- Press the  key to return to idle mode.

Note: This service need subscription to local operator and it supports the FSK CLI system only.

Reset Base

This option allows user to restore the base and Date/Time to the default setting.

Note: After reset the base, all the caller ID records stored in base and cordless handset, and all the phonebook and redial records stored in base will be cleared. Please write down the useful information before reset.

- Press MENU/OK key.
- Press ▲ or ▼ key to select SETUP BS and press MENU/OK key.
- Press ▲ or ▼ key to select RESET and press MENU/OK key, the LCD will display ENTER PIN (default setting = 0000).

- Input the correct PIN code by pressing numeric key, press MENU/OK key to confirm, and the LCD will display “RESET?”
- Press MENU/OK key to confirm.
- Press the  key to return to idle mode.

Date / Time

You can set the Date/Time displayed in idle mode. The default setting is “2007, 01/01 12:01 pm”.

- Press MENU/OK key.
- Press ▲ or ▼ key to select DATE/TIME and press MENU/OK key, the LCD will display “YEAR 2007”.
- Input the correct last two digits of year (range: 00-99) using number key, press MENU/OK key to confirm and then enter month and date setting.
- Input the correct date and month by numeric key, the format is: date/month (date range: 01-30/31, month range: 01-12) using number key, press MENU/OK key to confirm the setting and enter time setting.
- Input the correct time by numeric key,, the format is: hour/minute (hour range: 01-12 and 00-23, minute range: 00-59), and set the “am” or “pm” by pressing ▲ or ▼ key.
- Press MENU/OK key to confirm.
- Press the  key to return to idle mode.

Note: If the figure you input is over the range, you can't enter next setting menu even pressing MENU/OK key, you are required to enter the correct setting again.

Registration

Register

Up to 4 cordless handsets can be registered to one base.

- Press MENU/OK key.
- Press ▲ or ▼ key to select REGISTRATION and press MENU/OK key.
- Press ▲ or ▼ key to select REGISTER and press MENU/OK key, the LCD will display ENTER PIN (default setting = 0000).
- Input the correct PIN code and press MENU/OK key to begin to register the cordless handset, the LCD will display SEARCHING.

- Press and hold the mute key on base around 6 seconds until the base LCD show REGISTRATION.
- After Registered, press the  key to quit (during “SEARCHING” is displayed, handset can’t quit until time out) .

Note: 1. SUCCESSFUL will be shown on cordless handset if it is registered to the base. Cordless handset number eg.2 will be shown after it returns to idle mode.

2. NO BASE will be shown on cordless handset if it can’t register to the base within 1 minute, you have to register the handset again.

3. If the PIN code you input is wrong, registration will not succeed. Handset will display “WRONG PIN” after time out.

Remove Handset

This function allows user to remove the registered cordless handset from the base.

- Press MENU/OK key.
- Press ▲ or ▼ key to select REGISTRATION and press MENU/OK key.
- Press ▲ or ▼ key to select REMOVE HANDSET and press MENU/OK key, the LCD will display ENTER PIN.(default setting = 0000).
- Input the correct PIN code and press MENU/OK key.
- Press ▲ or ▼ key to select the cordless handset (1,2,3,4) you want to remove and press MENU/OK key, the LCD will display “REMOVE HANDSET?”
- Press MENU/OK key to confirm the setting.
- Press the  key to return to idle mode.

Note: 1. The removed cordless handset LCD will show “NOT REG”. You must register it again before using it.

2. If the PIN code you input is wrong, “WRONG PIN” will be shown on cordless handset LCD.

Basic Operation

Making External Calls

Pre-dialing

Post-dialling Using the Base



- Pick up the corded handset from the base or press **speaker** key, wait for a dial tone,
- Dial the desired telephone number.

Note: When the base is used, the handset will display “LINE IN USE”.

- Hang up the corded handset or press **speaker** key to end the call.

The call timer will be shown and last for about 2 seconds before return to idle mode.

Post-dialling Using the Cordless Handset

- Press the  or  key, wait for a dial tone, and then dial the desired telephone number.
- Press  key or place the cordless handset into the charger to end the call.

The call timer will be shown and last for about 2 seconds before return to idle mode.





Pre-dialing

Pre-dialing Using the Base

- Input the desired telephone number.
- Delete any incorrect digit by pressing **erase** key.
- Pick up the corded handset from the base or press **speaker** key, the number will be automatically dialed out.
- Hang up the corded handset or press **speaker** key to end the call.

The call timer will be shown and last for about 2 seconds before return to idle mode.

Pre-dialling Using the Cordless Handset

- Input the desired telephone number.
- Delete any incorrect digit by pressing  key.
- Press the  or  key, the number will be automatically dialled out.
- Press  key or place the cordless handset into the charger to end the call.

The call timer will be shown and last for about 2 seconds before return to idle mode.

Adjust the Receiver or Speaker Volume

You can adjust the receiver or speaker volume during a call (external or internal). There are 5 different volume levels

During a call:

- Press the Volume VOL + or VOL - key to adjust the volume on corded base.
- Press the Volume ▲ or ▼ key to adjust the volume on cordless handset.

Taking Calls

When the phone rings, the icon  will flash and the LCD on the base and cordless handset will show “Call”.

Take a Call Using the Base

- Pick up the corded handset from the base or press **speaker** key to answer a call.
- Hang up the corded handset or press **speaker** key to end the call.

Take a Call Using the Cordless Handset

- Take the cordless handset from the charging station, the connection is automatically established (when the AUTO TALK

function is active). Otherwise press  or  .

- Press  key or place the cordless handset into the charger to end the call.

Hands-free

Switch between Speakerphone & Receiver Using the Base

To switch to speakerphone mode, press **speaker** key and hang up the corded handset.

To switch to receiver mode, pick up the corded handset from the base.

Switch between Speakerphone & Receiver Using the Cordless Handset

To switch to speakerphone mode, press  key.



To switch to receiver mode, press  key again or press  key.

Making Internal Calls

You can make internal calls between base and cordless handset, or any two cordless handsets (if you have more than one cordless handset).

Base to Cordless Handset

- When base is in idle mode, press **intercom** key, “INT-NUMBER?” will be shown, input the cordless handset number. (1,2,3,4) you want to call.
- The called cordless handset will ring and the LCD will show “Base”.

- Press  or  key of the called cordless handset to answer.



Cordless Handset to Base

- When the cordless handset is in idle mode, press **int** key,

“INT-NUMBER?” will be shown, input the number “0”.

- The base will ring and the LCD will show the calling cordless handset’s name and number.
- Pick up the corded handset or press **speaker** key from the base to answer.

Cordless Handset to Cordless Handset

- When the cordless handset is in idle mode, press **int** key, “INT-NUMBER?” will be shown, input the cordless handset number (1,2,3,4) you want to call..
- The called cordless handset will ring and the LCD will show the calling cordless handset’s name and number.
- Press  or  key of the called cordless handset to answer.

Call Transfer



The function allows you to transfer an external call from base to a cordless handset, or from a cordless handset to base or another cordless handset.

- During an external call, press **intercom** key on base or **int** key on handset to put the external call on hold.
- Enter the number of the handset that you would like to transfer the call to (0 for base, 1-4 for cordless handset).
- When the paged handset or base answers the call, intercom is established.
- After calling base user or calling handset user hangs up (press , external line is then transferred..

Note: 1. There must be more than two handsets registered to the base, otherwise the call transfer function from one cordless handset to another cordless handset will be invalid;
2. If the internal call is not answered in 100 seconds after the paging, it will call back external line.

Three Party Conference



After receiving an external call, it is possible to include a second handset in the conversation.

- During an external call, Press  or  key of the called cordless handset to answer (If Base, Pick up the corded handset from the base or press **speaker** key).
- After calling base user or calling handset user hangs up (press ) , The remaining party can continuously connect to the external call.

Redial Function





The last 10 phone numbers you dial out are separately stored in base and cordless handset redial memory. The redial function of the base and cordless handset is the same.

Dial a number from the Redial memory



- Press REDIAL key on base or  redial key on cordless handset. If the redial memory is empty, EMPTY will be shown.
- Press  or  key to select the desired Redial number.
- Take telephone line with the base or cordless handset, the telephone number is automatically dialed out.

Note: If you want to edit the number before dialing out, press MENU/OK key to enter menu and select SELECT to edit the Redial number.

Save Redial Memory

- Press REDIAL key on base or  redial key on cordless handset.
- Press  or  key to select the desired redial number.
- Press MENU/OK key on the base or handset to enter menu, press  or  key to select SAVE NUMBER, press MENU/OK key, ENTER NAME will be shown and you can input the desired name. You must input the name; otherwise the record can't be saved.
- Press MENU/OK key on the base or handset to save.

Delete a Single Redial Memory

- Press REDIAL key on base or  redial key on cordless handset.
- Press  or  key to select the desired redial number.
- Press MENU/OK key on the base or handset to enter menu, press

▲ or ▼ key to select DELETE, press MENU/OK key again, CONFIRM? will be shown.

- Press MENU/OK key on the base or handset to confirm.

Delete All Redial Memory

- Press REDIAL key on base or  redial key on cordless handset.
- Press MENU/OK key on the base or handset to enter menu, press ▲ or ▼ key to select DELETE ALL, press MENU/OK key again, CONFIRM? will be shown.
- Press MENU/OK key on the base or handset to confirm.

Caller ID Service

The caller's information will be displayed and recorded if you have subscribed to Caller ID service from your local telephone company.

When the telephone rings, the caller's information will be displayed on the base and cordless handset LCD display. This information includes the phone number and name (if supported). The base or cordless handset can store up to 30 calls (up to 20 digits and 15 characters for each record). When the memory is full, a new call will automatically replace the oldest call in the memory.

Note: 1. If the caller's information includes Date/Time, the Date/Time will be stored into the record. The Date/Time display is also updated after receiving a call.

2. If the caller number is matched with one of phonebook memory, the matched name stored in the phonebook memory will be displayed.
3. If the incoming call is registered as "Private Number" and its caller ID information is withheld, LCD will show PRIVATE..
4. If the incoming call does not have Caller ID service or its service area is not linked to yours, the LCD will show UNAVAILABLE.
5. Display "MISSED CALLS" - call is missed or some Caller-ID memories not yet reviewed. Base will also show the  icon.
6. If the same call are received more than one time, the "RPT" icon will be shown when you review the record to prompt you this is a repeat call.
7. Display "LONG DISTANCE" - Long distance call is received.

Review Caller ID Record





- Press CID key and use ▲ or ▼ key to review all call records.
- If an area code is included in the caller number, you can press the # key to change the caller number display format.

For example:

If the displayed caller number is 123-4567 and your preset local area code is 888, press the # key once will display 888-123-4567. Press # key again will display 1-888-123-4567.

If the displayed caller number is 1-333-123-4567, press the # key once will display 333-123-4567. Press # key again will display 123-4567.

Dial from Call Log

- Press CID key and use ▲ or ▼ key to select the desired record.
- Lift the corded handset or press  on the handset base or  on the handset base or press the  key or  key on the cordless handset.

Note: If you want to edit the number before dialing out, press MENU/OK key to enter menu and select SELECT to edit the number.

Store Call Log into Phonebook

- Press CID key and use ▲ or ▼ key to select the desired record.
- Press MENU/OK key.
- Press ▲ or ▼ key to select SAVE NUMBER.
- Press MENU/OK key and use the numeric keypad to enter a name for the phone book entry. press the  /mute on the cordless handset or **erase** key on the corded base to delete any incorrect entries.

To enter the characters for a name, press the numeric key consecutively eg: letter H, press the number 4 key twice. If 2 consecutive characters are on the same key, enter the first character, then wait for the cursor to move to the right before entering the next character.

- Press the MENU/OK key to save the entry.

Key Assignment Overview

Key	Capital letter
1	1 space € £ \$ % & <>
2	A B C 2 Ä Å Á Â Ã Ä Æ Ç Ć Ć
3	D E F 3 È É Ê Ë Đ Ď Ě Ě
4	G H I 4 Ğ Ì Í Î Ï
5	J K L 5 Ŀ
6	M N O 6 Ö Ò Ó Ô Õ Ø Ñ Ń Ň Ó
7	P Q R S 7 ß Ş p ř ś š
8	T U V 8 Ü Ù Ú Û ť ŧ ů ú
9	W X Y Z 9 ý ŷ ž ž ž
0	. , ? ! 0 + - : ' " Δ ¿
#	# * @ \ / _ () = \$

Delete a Single Call Log



- Press CID key and use ▲ or ▼ key to select the desired record.
- Press MENU/OK key.
- Press ▲ or ▼ key to select DELETE.
- Press MENU/OK key, the LCD will show CONFIRM?, press MENU/OK key again to confirm.

Delete All Call Records

- Press CID key.
- Press MENU/OK key.
- Press ▲ or ▼ key to select DELETE ALL.
- Press MENU/OK key, the LCD will show CONFIRM?, press MENU/OK key again to confirm.

Caller ID Dial Back

When browsing Call Log memory, you can pick up the base corded handset or press the base speaker key or press the cordless handset speaker

 key or  key to dial back directly to the Caller Line Identification (CLI) number on the LCD.

Advanced Operation

Phonebook

Your corded base and cordless handset can each store up to 50 names and numbers, Each Phonebook memory can be up to 15 characters and 24 digits long.

Note: You can also view the Phonebook during a call

Review Phonebook

- Press  key on the cordless handset or **store** key on the corded base.

Note: If the phonebook is empty PHONEBOOK EMPTY will be shown.

- Press ▲ or ▼ key to review phonebook memories.
- You can search a name by inputting the first character.
- Review the phone number in accordance with the name by pressing * key.
- When you scroll to the end, “-----” will be shown.

Store Name and Number into Phonebook

- Press  key on the cordless handset or **store** key on the corded base.
- Press MENU/OK key to enter menu, select ADD NEW.
- Press MENU/OK key
- ENTER NUMBER will be shown, enter number using the keypad. Press and hold 0 key if a PAUSE is needed, character “P” will be shown.
- Press MENU/OK key.
- ENTER NAME will be shown, enter the name by pressing the keypad. If you need to delete any incorrect characters, press

cancel
the /mute on the cordless handset or **erase** key on the corded base.

To enter the characters for a name, press the numeric key consecutively eg: letter H you would press the number 4 key twice. If 2 consecutive characters are on the same key, enter the first character, then wait for the cursor to move to the right before entering the next character.

- Press MENU/OK key to save the record.

Note: When MEMORY FULL is shown, you must delete one or more unnecessary records before saving a new record.

Edit Phonebook Memory

- Press  key on the cordless handset or **store** key on the corded base and use ▲ or ▼ key to select the desired record.
- Press MENU/OK key.
- Press ▲ or ▼ key to select EDIT and press MENU/OK key.
- Use the keypad to edit the number entry (press ▲ or ▼ key to move the cursor).
- Press MENU/OK key.
- Use the keypad to edit the name entry (press ▲ or ▼ key to move cursor).
- Press MENU/OK key to save the entry.

Note: Delete a digit at left side of cursor, press ^{cancel}/mute on cordless handset or **erase** key on corded base.

Delete Phonebook Memory

- Press  key on the cordless handset or **store** key on the corded base and use ▲ or ▼ key to select the desired record.
- Press MENU/OK key.
- Press ▲ or ▼ key to select DELETE.
- Press MENU/OK key, the LCD will show CONFIRM? , Press MENU/OK key again to confirm.

Dial Record from Phonebook

- Press  key on the cordless handset or **store** key on the corded base and use ▲ or ▼ key to select the desired record
- Take telephone line with the base or cordless handset, the telephone number is automatically dialed out.

Note: If you want to edit the number before dialing out, press **MENU/OK** key to enter menu and select **SELECT** to edit the number first.

Special Feature

Page All Cordless Handsets from Base

- Press and hold **intercom** key on the base for 3 seconds, the base LCD will show **PAGING HANDSETS**, all the cordless handset will beep and LCD show **PAGING**.
- Press **EXIT** or **erase** key on the base or press any key on the cordless handset to stop. Paging sound will be stopped **after 30 seconds**.

Temporary Tone (for pulse or rotary service user)

In pulse dialing mode, you can switch to Tone dialing to access bank facilities etc. by pressing * key.

It will reset automatically to pulse dialing after you end the call.

Mute

- Press **MUTE** key on handset base or ^{cancel}/**mute** on cordless handset to active the mute feature during talking.
- The mute icon  will be shown.
- Press **MUTE** key on handset base or ^{cancel}/**mute** on cordless handset again to turn it off.

Pause

You can insert a 3 seconds **PAUSE** into the dialing or storing of a number into phonebook.

E.g. to dial number: 9 + **PAUSE** (press and hold 0 key) + telephone number.

Press and hold 0 key for 1.5 seconds, the LCD will show “P”.

Flash



Use FLASH key on corded base or flash key on cordless handset to activate custom calling services such as call waiting or call forwarding, which are available through your local telephone company. “R” will be shown on the LCD.

The FLASH key or R key can also be used to access a new dial tone without hanging up.

Note: Refer section of Base Setting - Flash Time to select Flash duration. If the function dial did not work normally, please contact with the vendor of the PBX or your local telephone company.

Keypad Lock (only for cordless handset)

The default setting is “Off”.

- To lock the keypad, press and hold **#** ^{on} key until a beep is heard during standby,  icon will be shown.
- To unlock the keypad, press and hold **#** key again until a beep is heard and  icon is disappear.

Note: When the key lock is activated, you can still be able to accept incoming calls.

Hold Call (only for base)

The line will be hold by pressing HOLD key, a music will be heard as a reminder.

Lift the corded handset or press **speaker** key or press HOLD key again to release the Hold function. The hold can also be released when the branch phone answer the call.

Troubleshooting Guide

When you forgot the base PIN code, follow the following procedures can RESET the PIN code to “0000”.

1. with the base is in standby mode, press MENU/OK key and key in “442737”.
2. Press **▲** or **▼** key, “FACTORY RESET” is shown.

3. Press MEN/OK key, “RESET” is shown
4. Press MENU/OK to confirm.
5. Press the exit key on base to quit.
6. Following “Registration” section to register all handsets again.

PROBLEMS	CAUSES	SOLUTIONS
Registration not work.	<p>The battery is not sufficiently charged.</p> <p>Handset and base station were not prepared for registration.</p> <p>Wrong PIN code is entered</p>	<p>Charge the battery for 14 hours (see Battery Charging).</p> <p>Unplug and then plug in the power adaptor.</p> <p>Enter correct PIN code again. (default is 0000)</p>
No display.	The battery has not been charged.	Charge the battery or replace them (see Battery Charging)
<p>No reactions to keystroke.</p> <p>No radio connection to the base station: blinking!</p>	<p>The keypad is locked.</p> <p>The handset is outside the base station range.</p> <p>The handset is not registered.</p> <p>The base station does not work.</p>	<p>Press # key longer than 2 seconds.</p> <p>Move closer to the base station.</p> <p>Register the handset (see Registering Handset).</p> <p>Unplug and then plug the power adaptor to the power outlet (120V AC / 60 Hz) and the other end into the power jack on base bottom.</p>
Base or cordless handset displays	The handset is outside the base station range	Move closer to the base station.

<p>“NOT AVAILABLE”</p>	<p>The base station does not work.</p> <p>Either cordless handset or base is in use.</p>	<p>Unplug and then plug the power adaptor to the power outlet (120V AC / 60 Hz) and the other end into the power jack on base bottom.</p> <p>Wait for cordless handset or base return idle state.</p>
------------------------	--	---

General Product Care

To keep your unit working and looking good, follow these guidelines:

- Avoid dropping the handset, as well as other rough treatment to the phone.
- Wipe the base station with a damp cloth or an antistatic wipe. Never use a dry cloth as this can cause static discharge.
- Retain the original packaging in case you need to ship the phone at a later date.
- Periodically clean the charge contacts on the handset and remote charger with a clean pencil eraser.

Causes of Poor Reception

- Aluminum siding.
- Foil backing on insulation.
- Heating ducts and other metal construction that can shield radio signals.
- You're too close to appliances such as microwaves, stoves, televisions, entertainment centers, etc.
- Atmospheric conditions, such as strong storms.

- Base is installed in the basement or lower floor of the house.
- Base is plugged into AC outlet with other electronic devices.
- Handset battery is low.

Accessory Information

DESCRIPTION	MODEL NO.
DC power adapter for base unit	5-2823
DC power adaptor for handset charge cradle	5-2824
Battery Pack	5-2826

To place order, have your Visa, MasterCard, or Discover Card ready and call toll-free 1-800-338-0376. A shipping and handling fee will be charged upon ordering. We are required by law to collect appropriate sales tax for each individual state, country, and locality to which the merchandise is being sent. Items are subject to availability.

Service

If trouble is experienced with this equipment, for repair or warranty information, please contact customer service at 1-800-448-0329. If the equipment is causing harm to the telephone network, the telephone company may request that you disconnect the equipment until the problem is resolved.

This product may be serviced only by the manufacturer or its authorized service agents. Changes or modifications not expressly approved by Thomson Inc. could void the user's authority to operate this product. For instructions on how to obtain service, refer to the warranty included in this guide or call customer service at 1-800-448-0329.

Or refer inquiries to:

Thomson Inc.
 Manager, Consumer Relations

PO Box 1976

Indianapolis, IN 46206-1976

Attach your sales receipt to the booklet for future reference or jot down the date this product was purchased or received as a gift. This information will be valuable if service should be required during the warranty period.

Purchase date

Name of store

Limited Warranty

What your warranty covers:

- Defects in materials or workmanship.

For how long after your purchase:

- One year, from date of purchase.

(The warranty period for rental units begins with the first rental or 45 days from date of shipment to the rental firm, whichever comes first.)

What we will do:

- Provide you with a new or, at our option, a refurbished unit. The exchange unit is under warranty for the remainder of the original product's warranty period.

How you get service:

- Properly pack your unit. Include any cables, etc., which were originally provided with the product. We recommend using the original carton and packing materials.
- "Proof of purchase in the form of a bill of sale or receipted invoice which is evidence that the product is within the warranty period, must be presented to obtain warranty service." For rental firms, proof of first rental is also required. Also print your name and address and a description of the defect. Send via standard UPS or its equivalent to:

Thomson Inc.

11721 B Alameda Ave.

Socorro, Texas 79927

- Pay any charges billed to you by the Exchange Center for service not covered by the warranty.
- Insure your shipment for loss or damage. Thomson Inc. accepts no liability in case of damage or loss.
- A new or refurbished unit will be shipped to you freight prepaid.

What your warranty does not cover:

- Customer instruction. (Your User's Guide provides information regarding operating instructions and user controls. Any additional information, should be obtained from your dealer.)
- Installation and setup service adjustments.
- Batteries.
- Damage from misuse or neglect.
- Products which have been modified or incorporated into other products.
- Products purchased or serviced outside the USA.
- Acts of nature, such as but not limited to lightning damage.

Product Registration:

- Please complete and mail the Product Registration Card packed with your unit. It will make it easier to contact you should it ever be necessary. The return of the card is not required for warranty coverage.

Limitation of Warranty:

- The warranty stated above is the only warranty applicable to this product. All other warranties, express or implied (including all implied warranties of merchantability or fitness for a particular purpose) are hereby disclaimed. No verbal or written information given by Thomson Inc., its agents, or employees shall create a guaranty or in any way increase the scope of this warranty.
- Repair or replacement as provided under this warranty is the exclusive remedy of the consumer. Thomson Inc. shall not be liable for incidental or consequential damages resulting from the use of this product or arising out of any breach of any express or implied warranty on this product. This disclaimer of warranties and limited warranty are governed by the laws of the state of Indiana. Except to the extent prohibited by applicable law, any implied warranty of merchantability or fitness for a particular

purpose on this product is limited to the applicable warranty period set forth above.

How state law relates to this warranty:

- Some states do not allow the exclusion nor limitation of incidental or consequential damages, or limitations on how long an implied warranty lasts so the above limitations or exclusions may not apply to you.
- This warranty gives you specific legal rights, and you also may have other rights that vary from state to state.

If you purchased your product outside the USA:

- This warranty does not apply. Contact your dealer for warranty information.