

User's Guide

3922 496 30771 April 2009 v3.02

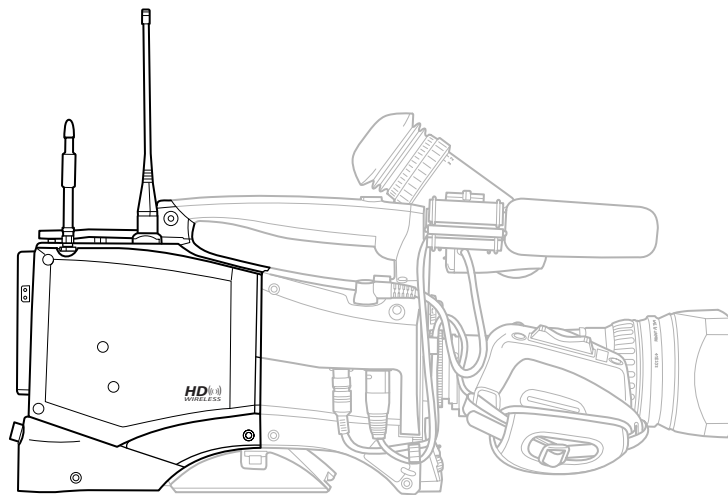

HD Wireless

HDTV Digital Wireless camera system

Declaration of conformity

We, Grass Valley Nederland B.V., Kapittelweg 10, 4827 HG Breda, The Netherlands, declare under our sole responsibility that the LDK 4453/22, LDK 4453/25, LDK 4454/60, LDK 4455/50, LDK 4460/XX, LDK 4470/XX, LDK 5464/XX, LDK 5465/20, LDK 5466/22 and LDK 5466/25 are in compliance with the following standards:

- EN60950: Safety
- EN301489-3: EMC for Radio Devices
- EN 302 064: Radio
- ETS 300 220: Radio

following the provisions of:

- RTT&E Directive 1999/5/CE

We, Grass Valley Nederland B.V., Kapittelweg 10, 4827 HG Breda, The Netherlands, declare under our sole responsibility that the remainder of the components used in this product is in compliance with the following standards:

- EN60065: Safety
- EN55103-1: EMC (Emission)
- EN55103-2: EMC (Immunity)

following the provisions of:

- a. the Low Voltage directive 2006/95/EC
- b. the EMC directive 2004/108/EC

FCC Class A Statement for LDK 5453/20 and LDK 5466/20

These products generate, use, and can radiate radio frequency energy and if not installed and used in accordance with the instructions, may cause interference to radio communications.

These have been tested and found to comply with the limits for a class A digital device pursuant to part 74 of the FCC rules, which are designed to provide reasonable protection against such interference when operated in a commercial environment.

Operation of these products in a residential area is likely to cause interference in which case the user at his own expense will be required to take whatever measures may be required to correct the interference.

Copyright

Copyright Grass Valley Nederland B.V. 2009. Copying of this document and giving it to others, and the use or communication of the contents thereof, are forbidden without express authority. Offenders are liable to the payment of damages. All rights are reserved in the event of the grant of a patent or the registration of a utility model or design. Liable to technical alterations in the course of further development.

Table of contents

Chapter 1 – Introduction

1.1	Technology	15
1.2	Features	16
1.3	System composition	17
1.4	Unit identification	18
1.5	Packing/unpacking	19

Chapter 2 – Installation

2.1	Configurations	21
2.2	Wireless camera adapter (WCA)	23
2.2.1	Attaching an adapter	23
2.2.2	Attaching antennas to the adapter	24
2.2.3	Attaching a battery to the camera adapter	25
2.3	Antenna Management Unit (AMU)	26
2.3.1	Antenna positioning	26
2.3.2	Antenna unit assembly	26
2.4	Wireless Control Unit (WCU)	28
2.4.1	Connecting the studio intercom system	29
2.4.2	Connecting the studio signalling	30

Chapter 3 – Using menu s

3.1	Menus	35
3.2	Setting up the WCU menu	35
3.2.1	Using the rotary/push button to set up the WCU	35
3.2.2	Using an OCP 400 to set up the WCU	36
3.3	Navigating the WCU menus	37
3.3.1	Entering the system menu	37
3.3.2	Finding your way	37
3.3.3	Leaving the Systems Menu	38
3.3.4	Making changes	39
3.3.5	Using the Recall File to undo changes	39

Chapter 4 – Setting up

4.1	Wireless Insight	41
4.2	Wireless Camera Adapter (WCA)	41
4.2.1	Select video frequency channel	42
4.2.2	Select data frequency channel	42
4.2.3	Select transmission profiles	42
4.2.4	Select camera number	43
4.2.5	Camera head audio	43
4.2.6	Intercom	44
4.2.7	Viewfinder indications	45

4.3	Antenna Management Unit (AMU)	46
4.3.1	AMU indicators	46
4.3.2	Selecting AMU identifier	47
4.4	Wireless Control Unit (WCU)	48
4.4.1	Select a video acquisition mode	48
4.4.2	Set transmission frequencies	48
4.4.3	Set transmission profiles	48
4.4.4	Select camera number	48
4.4.5	WCU audio menu	49
4.4.6	WCU intercom menu	49
4.4.7	Signalling	49
4.4.8	WCU controls and indicators	50

Chapter 5 – Menu contents

5.1	Wireless Control Unit menu structure	53
5.1.1	WCU user levels	54
5.2	WCU menu contents	55
5.2.1	WCU Video menu	55
5.2.2	WCU Monitoring menu	55
5.2.3	WCU Audio/Intercom menu	56
5.2.4	WCU SDTV menu	56
5.2.5	WCU System menu	57
5.2.6	WCU System menu	58
5.2.7	WCU Files menu	59
5.2.8	WCU Diagnostics menu	60
5.3	Camera (LDK 8000) install menu for WCA	61

Chapter 6 – Connectors

6.1	WCA connectors	63
6.1.1	Viewfinder video output connector	64
6.1.2	HD - SDI connector	64
6.1.3	Audio microphone 1 connector	64
6.1.4	Audio microphone 2 connector	65
6.1.5	Intercom headset connector	65
6.1.6	DC power input socket	66
6.1.7	DC power and tally output connector	66
6.2	AMU connectors	67
6.2.1	Triax connector	67
6.2.2	Data emitter socket (DATA)	68
6.2.3	RF receiver connectors (UHF IN)	68
6.2.4	RF receiver connectors (UHF OUT)	68

6.3	WCU connectors	69
6.3.1	Triax connectors	69
6.3.2	Power connector	70
6.3.3	Intercom connector	70
6.3.4	Signalling connector	71
6.3.5	Audio out connectors	71
6.3.6	Data connector	72
6.3.7	Ethernet connector	72
6.3.8	Reference input connectors	72
6.3.9	CVBS output connectors	73
6.3.10	SDI output connectors 1 and 2	73
6.3.11	SDI output connector 3	73

Chapter 7 – Specifications

7.1	Specifications for Antenna Management Unit (AMU)	75
7.2	Specifications for RF receiver units	75
7.3	Specifications for RF data emitter unit	76
7.4	Specifications for Wireless Control Unit (WCU)	76
7.5	Specifications for Wireless Camera Adapter (WCA)	77
7.6	Specifications for LDK 5455 Video Booster (optional)	78

Chapter 8 – Exchanging the RF module

Chapter 9 – Installing the Video booster

End-of-life product recycling

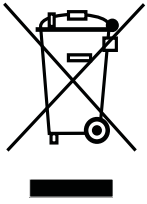

Grass Valley's innovation and excellence in product design also extends to the programs we've established to manage the recycling of our products. Grass Valley has developed a comprehensive end-of-life product take back program for recycle or disposal of end-of-life products. Our program meets the requirements of the European Union's WEEE Directive and in the United States from the Environmental Protection Agency, individual state or local agencies.

Grass Valley's end-of-life product take back program assures proper disposal by use of Best Available Technology. This program accepts any Grass Valley branded equipment. Upon request, a Certificate of Recycling or a Certificate of Destruction, depending on the ultimate disposition of the product, can be sent to the requester.

Grass Valley will be responsible for all costs associated with recycling and disposal, including freight, however you are responsible for the removal of the equipment from your facility and packing the equipment ready for pickup.

For further information on the Grass Valley product take back system please contact Grass Valley at + 800 80 80 20 20 or +33 1 48 25 20 20 from most other countries. In the US and Canada please call 800-547-8949 or 530-478-4148. Ask to be connected to the EH&S Department. In addition, information concerning the program can be found at:

www.grassvalley.com/environment

Trademarks

Grass Valley and Infinity are trademarks of Grass Valley, Inc. All other tradenames referenced are service marks, trademarks, or registered trademarks of their respective companies.

Website

Visit the Grass Valley public website to download the latest user's guide updates and additional information about your broadcast product:

www.grassvalley.com

Important information

Read these instructions carefully and retain them for future reference.

Safety Summary

This information is intended as a guide for trained and qualified personnel who are aware of the dangers involved in handling potentially hazardous electrical/electronic equipment. It is not intended to contain a complete list of all safety precautions which should be observed by personnel in using this or other electronic equipment.

The installation, maintenance and service of this equipment involves risks both to personnel and equipment and must be performed only by qualified personnel exercising due care.

Personnel engaged in the installation, operation, maintenance or servicing of this equipment are urged to become familiar with First Aid theory and practises.

During installation and operation of this equipment, local building safety and fire protection standards must be observed.

Before connecting the equipment to the power supply of the installation, verify the proper functioning of the protective earth lead.

Whenever it is likely that safe operation is impaired, the apparatus must be made inoperative and secured against any unintended operation. The appropriate servicing authority must then be informed. For example, safety is likely to be impaired if the apparatus fails to perform the intended function or shows visible damage.

Any changes or modifications not expressly approved in this manual could void your authority to operate this equipment.

This product has been designed and tested according to EN-60950.

Attention

The radio frequency channels used by this equipment may be constrained or restricted by law in the country where you are operating this equipment. Check before using this equipment that all applicable licenses or authorizations have been obtained.

Any modifications shall void the warranty and could make the user liable for any disturbances caused by the modified equipment.

Read and comply with the warning and caution notices that appear in the manual.

- Warnings indicate danger that requires correct procedures or practices to prevent death or injury to personnel.
- Cautions indicate procedures or practices that should be followed to prevent damage or destruction to equipment or property.

Warnings

- Do not modify this equipment.
- Do not use this equipment in areas where it may endanger safety such as hospitals or airports.
- This equipment generates electromagnetic radio frequencies. Installation must conform to the instructions given in this manual.
- Installation of this equipment must only be performed by qualified personnel.
- Do not use any accessories other than those recommended by the manufacturer.
- The current and voltages present in this equipment are dangerous. Personnel must at all times follow the safety regulations.
- Always disconnect power before removing covers or panels.
- Always discharge high voltage points before servicing.
- Never make internal adjustments, perform maintenance or service when alone or when fatigued.
- In case of an emergency ensure that the power is disconnected.
- Mount equipment so that power lead can be accessed to disconnect power.
- The power lead of the WCU must always be connected to a power socket with a protective earth.
- Any interruption of the protection conductor inside or outside the apparatus, or disconnection of the protective earth terminal, is likely to make the apparatus dangerous. Intentional interruption is prohibited.
- Use only the antennas supplied. Do not use the camera without antennas. Switch off power to the units before detaching antennas.
- Avoid contact with the right side cover of the camera during operation as it may become hot.

Cautions

- To prevent risk of overheating, ventilate the product correctly.
- Connect the product only to a power source with the specified voltage rating.
- Always switch off the camera before changing the battery or changing the power supply.
- Any cables connected to the camera must be less than 3 m to avoid interference.

Summary of cautions used in this manual:

- Always disconnect from the power supply before opening the adapter.
- Connection panel position in the rack should ensure that the plug and power cord are within easy reach for switching off purposes.
- Be extremely careful with the connectors between the camera head and the adapter. Do not allow the guide pins to damage the pins of the connector. Follow these steps in the order given. Tightening the screws in the wrong order could result in mechanical damage to the camera. Loosening the screws in the wrong order could result in mechanical damage to the camera.
- Never supply power to an adapter without first ensuring that the antennas are attached.
- Use only the antennas supplied.
- Switch off the power to the units before detaching the antennas.
- The input voltage to the camera must stay between +11 VDC and +17 Vdc.
- Disconnect the power to the WCU before opening the AMU.

Triax cable systems

- Only connect a Triax cable from the same LDK camera family to the unit.
- Do not allow system earth currents to exceed 1.5 A in the outer shield of the Triax cable or 0.2 A in other cable shields.
- To avoid excessive earth currents in a Triax system, galvanically separate the power earth connection of equipment connected to the AMU from the AMU earth.
- It is strictly prohibited to short circuit the inner and outer shields of a Triax cable used to connect an AMU to a WCU.

Galvanic separation

Because of the nature of Triax systems, with long distances between AMU and WCU, the risk of earth currents flowing is greater. These earth currents can result in damage to the equipment.

To prevent earth currents from flowing in the Triax system, we recommend galvanic separation of earthed equipment connected to the AMU. This separation can be achieved by using an isolation transformer between the local power outlet and the equipment connected to the AMU. Alternatively, use equipment that has a double insulation and therefore does not require an earth connection.

Precautions

To ensure continual high performance from the camera take the following precautions into consideration:

- Avoid very damp places. If the environment is wet or damp a rain cover must be used to protect the unit.
- Do not subject the unit to severe shocks or vibration.
- Do not expose the camera to extreme temperatures.
- Do not leave the unit in direct sunlight or close to heating appliances for extended periods.
- Do not allow sunlight to shine into the viewfinder.
- Do not allow LASER beams to shine into the lens as this could damage the CCD sensors.
- Avoid extreme highlights as these can cause various kinds of optical reflections.
- Be careful when connecting and disconnecting triax cables.
 - Do not mix triax units from different types of camera systems (HD with SD, RGB triax with digital triax).
 - Make connections swiftly and firmly to avoid false error messages.

Mains lead wiring for UK users

The wires in the mains lead are coloured in accordance with the following code:

GREEN and YELLOW- EARTH

BLUE- NEUTRAL

BROWN- LIVE

As the colours of the wires in the mains lead of this apparatus may not correspond with the coloured markings identifying the terminals in your plug proceed as follows:

- The wire coloured GREEN and YELLOW must be connected to the terminal on the plug marked with the letter E or by the safety earth symbol  or coloured GREEN or GREEN and YELLOW.
- The wire coloured BROWN must be connected to the terminal marked with the letter L or coloured RED.
- The wire coloured BLUE must be connected to the terminal marked with the letter N or coloured BLACK.

Ensure that your equipment is connected correctly - if you are in any doubt consult a qualified electrician.

Sicherheit

Diese Informationen sind als Leitfaden für qualifiziertes Fachpersonal gedacht, das die Gefahren beim Umgang mit potenziell gefährlicher elektrischer/elektronischer Ausrüstung kennt. Es handelt sich dabei nicht um eine vollständige Zusammenstellung aller Sicherheitsvorkehrungen, die beim Gebrauch dieser oder anderer elektronischer Geräte zu beachten sind.

Die Montage, Wartung und Instandsetzung dieser Ausrüstung ist mit Risiken für Personal und Ausrüstung verbunden und darf nur von qualifiziertem Personal vorgenommen werden, wobei mit der nötigen Sorgfalt vorzugehen ist.

Mit der Montage, Bedienung, Instandhaltung oder Instandsetzung dieser Ausrüstung betrauten Personen wird dringend geraten, sich mit der Theorie und Praxis der Ersten Hilfe vertraut zu machen.

Beim Einbau und Betrieb dieser Ausrüstung müssen die örtlichen Gebäudesicherheits- und Brandschutzvorschriften beachtet werden.

Vor dem Anschluss der Ausrüstung an die Stromversorgung der Anlage muss überprüft werden, ob der Schutzleiter intakt ist.

Wenn eine Beeinträchtigung des sicheren Betriebs wahrscheinlich ist, muss das Gerät außer Betrieb gesetzt und gegen ungewollten Betrieb gesichert werden. Dann muss der zuständige Kundendienst benachrichtigt werden. Eine Beeinträchtigung der Sicherheit ist zum Beispiel dann wahrscheinlich, wenn das Gerät nicht wie vorgesehen funktioniert oder einen sichtbaren Schaden aufweist.

Dieses Produkt wurde nach EN-60950 entwickelt und geprüft.

Wichtig

Die für diese Ausrüstung verwendeten Funkfrequenzkanäle können in dem Land, in dem diese Ausrüstung betrieben wird, gesetzlichen Beschränkungen unterliegen. Prüfen Sie vor dem Einsatz dieser Ausrüstung nach, ob alle relevanten Zulassungen bzw. Genehmigungen vorliegen.

Änderungen haben zur Folge, dass die Garantie ungültig wird und der Benutzer für etwaige durch die veränderte Ausrüstung verursachte Störungen haftbar gemacht werden könnte.

Bei der Durchführung von Servicearbeiten sind die mit "Achtung" und "Vorsicht" gekennzeichneten Warnhinweise in den Handbüchern zu lesen und zu beachten.

- Mit "Vorsicht" wird auf eine Gefahr hingewiesen, die korrekte Arbeits- oder Verfahrensweisen erfordert, um Tod oder Verletzung zu verhindern.
- Mit "Achtung" werden Arbeitsanweisungen gekennzeichnet, die zu befolgen sind, um eine Beschädigung oder Zerstörung der Ausrüstung bzw. von Eigentum zu verhindern.

Vorsicht

- An dieser Ausrüstung dürfen keine Änderungen vorgenommen werden.
- Diese Ausrüstung darf nicht in Bereichen eingesetzt werden, in denen Sie die Sicherheit gefährden könnte (z.B. Krankenhäuser oder Flughäfen).
- Diese Ausrüstung erzeugt elektromagnetische Funkfrequenzen. Die Montage muss gemäss den Anweisungen in diesem Handbuch erfolgen.
- Diese Informationen vor der Montage oder Wartung und Instandsetzung dieser Ausrüstung genau durchlesen
- Die Montage dieser Ausrüstung darf nur von Fachpersonal vorgenommen werden.
- Es darf nur das vom Hersteller empfohlene Zubehör verwendet werden.
- Die sStromstärke und Spannungen in dieser Ausrüstung sind gefährlich. Die Sicherheitsvorschriften sind vom Personal stets einzuhalten.
- Vor dem Abnehmen von Abdeckungen oder Verkleidungen ist stets die Stromzufuhr abzuschalten.
- Vor der Ausführung von Wartungs- und Instandsetzungsarbeiten sind Hochspannungspunkte stets elektrisch zu entladen.
- Nehmen Sie nie interne Einstellungen vor und führen Sie nie Wartungs- oder Instandsetzungsarbeiten aus, wenn Sie allein oder ermüdet sind.
- Bei Eintreten eines Notfalls unbedingt die Stromzufuhr abschalten.
- Ausrüstung so montieren, dass das Netzkabel zum Abschalten der Stromzufuhr zugänglich ist.
- Das Netzkabel des WCU muss immer an eine Netzdose mit einer Schutzerdung angeschlossen werden.
- Jede Unterbrechung des Schutzleiters innerhalb oder ausserhalb des Geräts oder Trennung der Schutzleiteranschlussklemme könnte das Gerät gefährlich machen. Eine absichtliche Unterbrechung ist untersagt.
- Es dürfen nur Sicherungen des vorgeschriebenen Typs und Nennwerts verwendet werden.
- Es dürfen nur die mitgelieferten Antennen verwendet werden. Die Kamera darf nicht ohne Antennen betrieben werden. Vor dem Antennenabbau muss die Stromzufuhr zu den Geräten abgeschaltet werden.
- Die rechtsseitige Abdeckung der Kameragehäuse nicht anrühren weil das Oberfläch heiß werden kann.

Achtung

- Um einer Überhitzungsgefahr vorzubeugen, ist das Produkt korrekt zu belüften.
- Das Produkt darf nur an eine Stromquelle mit der vorgeschriebenen Nennspannung angeschlossen werden.
- Niemals ein analoges Triax-System an ein digitales Triax-System anschließen.
- System-Erdströme dürfen 1,5 A in der äußeren Abschirmung des Triax-Kabels bzw. 0,2 A in anderen Kabelschirmen nicht übersteigen.
- Die innere und äußere Abschirmung des Triax-Kabels nicht kurzschließen.
- Die Kamera vor dem Wechsel der Batterie oder dem Wechsel der Stromversorgung immer ausschalten.
- Alle an die Kamera angeschlossenen Kabel müssen weniger als 3 m lang sein, um Störungen zu vermeiden.

Zusammenstellung von in diesem Handbuch verwendeten Warnhinweisen:

- Immer von der Netzversorgung trennen, bevor der Adapter geöffnet wird.
- Stecker zwischen Kamerakopf und Adapter mit äußerster Vorsicht handhaben. Darauf achten, dass die Steckerstifte nicht durch die Führungsstifte beschädigt werden.
- Diese Schritte in der angegebenen Reihenfolge ausführen.
- Das Anziehen der Schrauben in der falschen Reihenfolge kann zu mechanischen Schäden an der Kamera führen.
- Das Lösen der Schrauben in der falschen Reihenfolge kann zu mechanischen Schäden an der Kamera führen.
- Niemals einem Adapter Strom zuführen, ohne sich zuerst zu vergewissern, dass die Antennen angebracht sind.
- Es dürfen nur die mitgelieferten Antennen verwendet werden.
- Vor dem Abnehmen der Antennen muss die Stromzufuhr zu den Geräten abgeschaltet werden.
- Die Eingangsspannung darf nie +17 VDC überschreiten.
- Vor dem Öffnen des AMU muss die Stromzufuhr zum WCU abgeschaltet werden.

Chapter 1

Introduction

1.1 Technology

The HD wireless system docks to the Grass Valley HD family of LDK cameras to form an HD Digital Wireless Camera System. It supports 1080i50/60, 720p50/60 and 1080psF25/29.97 acquisition while using an innovative approach both to compression and transmission.

For compression, the HD wireless system uses state-of-the-art JPEG 2000 compression technology with a 10-bit, end-to-end signal. You can use intra-field or spatial/temporal compression. What's more, there is no MPEG-style group of pictures (GoP). Consequently every frame is of the same high quality for postprocessing and editing.

For transmission, this bi-directional system provides genlock and full control of the camera in the same way as with a triax cable system. Coupled with a high bit-rate protocol (based on the 802.16 physical layer), it features low latency, enabling you to integrate wireless shots into your production with imperceptible video-to-audio delay. To fulfill specific requirements in different environments a set of profiles allow you to balance between the robustness of the wireless transmission and its bit-rate. The high-performance digital transmission means that the system is omnidirectional with no adverse effects from multi-path reflections.

Shooting range

The HD wireless system features a three-antenna diversity set. This receiving unit, when suitably placed, together with a video output power of 60 mW, offers you a shooting range of up to 150 m (500 ft). This shooting area can be extended to up to 400 m (1,300 ft) using the optional LDK 5451 Video Booster. The built-in data booster provides coverage of up to 1,000 m (3,280 ft) for the data link.

Adding a second antenna set can readily extend the coverage area, letting you move, for example, from a stadium to a dressing room. The system switches automatically and seamless between the two antenna sets.

The connection between a base station and the wireless system's antenna set uses conventional Triax cable, enabling you to locate an antenna up to 600 m (1,970 ft) from the base station using 11 mm (0.43 in) Triax cable. The HD wireless camera system is fully compatible with studio production facilities, the Grass Valley C2IP camera control system, and utilizes the same operational control panels as other Grass Valley LDK series cameras using the C2IP system.

The HD Wireless camera system integrates perfectly into your existing set-up. It is a flexible camera system that is equally at home in the studio or out on location in an outside broadcast environment.

1.2 Features

- Excellent HD picture quality using powerful JPEG 2000-based compression
- Supports 1080i50/60, 720p50/60 and 1080psF25/29.97 formats
- Robust and reliable transmission based on a modified 802.16 physical layer.
- Coverage area up to 150 m (500 ft).
- Three-antenna diversity system for transmission reliability
- Omni-directional antenna system for maximum flexibility
- Low latency performance and genlock features
- Easy integration in studio and stadium environment with standard triax cameras
- Choice of transmission profiles to fulfill specific production needs
- Supports C2IP control systems and OCP 400 control panels
- Dockable with LDK HD camera heads
- On-screen display selection of video and data transmission frequencies
- End-to-end digital processing with 10-bit quality level
- Support of roaming when using two antenna sets for increased coverage
- Freeze frame in the case of interrupted video link
- Optional video booster available for long-transmission applications

1.3 System composition

A wireless system includes:

- A wireless camera adapter (WCA) including RF module, a video antenna and a data antenna.
- An antenna management unit (AMU).
- Set of three RF Receiver units with three matching video antennas.
- Data emitter and booster unit with matching data antenna.
- An antenna bracket to mount RF receiver and data emitter, and antennas.
- A 15 m (50 ft) antenna cable set consisting of three coax cables with BNC connectors and an RS 422 screened cable with a 9-pin D connector.
- A wireless control unit (WCU).
- A cable (ordering code 47233914AB) for use with Grass Valley's Wireless Insight software.

For a complete Digital Wireless Camera system the following elements must be added:

- An HD LDK camera head and viewfinder
- A broadcast lens
- Triax and network cables

For full remote control:

- An Operational Control Panel (OCP 400) or
- A Multiple Control Panel (MCP 400)

To expand the operating range of the camera an additional AMU with antenna set can be added to the system.



Note

The camera head, lens, viewfinder, control panels, Triax cables and network cables are not included with an HD wireless system.

1.4 Unit identification

Unit	Type number
HD Wireless Control Unit (Fischer)	LDK 4470/10
HD Wireless Control Unit (Trilock)	LDK 4470/20
HD Wireless Control Unit (ARD)	LDK 4470/30
HD Wireless Control Unit (Lemo/4E)	LDK 4470/40
HD Wireless Control Unit (Lemo/BBC)	LDK 4470/50
HD Wireless Control Unit (Lemo/3T)	LDK 4470/60
HD Antenna Management Unit (Fischer)	LDK 4460/10
HD Antenna Management Unit (Trilock)	LDK 4460/20
HD Antenna Management Unit (ARD)	LDK 4460/30
HD Antenna Management Unit (Lemo/4E)	LDK 4460/40
HD Antenna Management Unit (Lemo/BBC)	LDK 4460/50
HD Antenna Management Unit (Lemo/3T)	LDK 4460/60
RF Receiver antenna set (3x) for 2.0 - 2.2 GHz	LDK 4453/20
RF Receiver antenna set (3x) for 2.2 - 2.4 GHz	LDK 4453/22
RF Receiver antenna set (3x) for 2.5 - 2.7 GHz	LDK 4453/25
RF Data emitter 456 MHz	LDK 4454/60
RF Data booster (included in system)	LDK 4455/50
HD Wireless Camera Adapter (Anton Bauer battery plate)	LDK 5464/00
HD Wireless Camera Adapter (IDX battery plate)	LDK 5464/10
HD RF Data Module Wireless adapter 456 MHz	LDK 5465/20 (included in LDK 5464/xx adaptor)
HD RF Module Wireless adapter for 2.0 - 2.2 GHz	LDK 5466/20
HD RF Module Wireless adapter for 2.2 - 2.4 GHz	LDK 5466/22
HD RF Module Wireless adapter for 2.5 - 2.7 GHz	LDK 5466/25
COFDM Video Booster 500 mW (Anton Bauer batt. plate)	LDK 5455/50
COFDM Video Booster 500 mW (IDX batt. plate)	LDK 5455/60
HD Antenna N-type for 2.0 - 2.2 GHz	LDK 5457/20
HD Antenna N-type for 2.2 - 2.4 GHz	LDK 5457/22
HD Antenna N-type for 2.5 - 2.7 GHz	LDK 5457/25
19-inch rack mounting kit for one WCU	BDT05701AA
Coupling kit for two WCUs	BDT05700AA

1.5 Packing/unpacking

Inspect the shipping container for evidence of damage immediately after receipt. If the shipping container or cushioning material is damaged, it should be kept until the contents of the shipment have been checked for completeness and the units have been checked mechanically and electrically.

The shipping container should be placed upright and opened from the top. Remove the cushioning material and lift out the contents. The contents of the shipment should be checked against the packing list. If the contents are incomplete, if there is mechanical damage or defect, or if the units do not perform correctly when unpacked, notify your Grass Valley sales or service centre within eight days. If the shipping container shows signs of damage or stress, notify the carrier as well.

If a unit is being returned to Grass Valley for servicing, try to use the containers and materials of the original packaging. Attach a tag indicating the type of service required, return address, model number, full serial number and the return number which will be supplied by your Grass Valley service centre.

If the original packing can no longer be used, the following general instructions should be used for repacking with commercially available materials:

1. Wrap unit in heavy paper or plastic.
2. Use strong shipping container.
3. Use a layer of shock-absorbing material around all sides of the unit to provide firm cushioning and prevent movement inside container.
4. Seal shipping container securely.
5. Mark shipping container FRAGILE to ensure careful handling.

Chapter 2

Installation

2.1 Configurations

This wireless transmission system combines with an HD LDK camera head to form a HD Digital Wireless Camera system. The camera head with the attached Wireless Camera Adapter (WCA), communicates wirelessly with the Antenna Management Unit (AMU). The AMU is connected to the Wireless Control Unit (WCU) via a Triax cable.

For different RF frequency ranges, different wideband RF modules are available which cover the ranges 2.2 to 2.4 GHz, 2.0 to 2.2 GHz or 2.5 to 2.7 GHz using 18 MHz bandwidth.

Output video signals

The WCU delivers three SDI video signals for the studio system. Either HD or SD output signals can be selected for the three SDI output connectors in the WCU **Video** menu. SDI outputs 1 and 2 are always the same (HD or SD) but SDI output 3 can be set independently.

Two analog CVBS and a digital monitoring signal (SDI output 3) are available from the WCU. These signals carry the On-Screen Display (OSD) texts and are intended for use in a control room.

The SDI outputs 1 and 2 do not contain OSD information and are intended for use in a production room.

Control

Remote control of the camera is achieved through the C2IP network that can be connected to the WCU. Control panels such as the OCP 400 can be used to gain full access to the camera. Set the parameters for the control network in the WCU **System** menu.

Increased range

To expand the operating range of the camera an additional AMU with antenna set can be added to the system. The WCU selects automatically between the two receiving sets without a picture break (roaming).

Figure 2-1. Camera wireless system

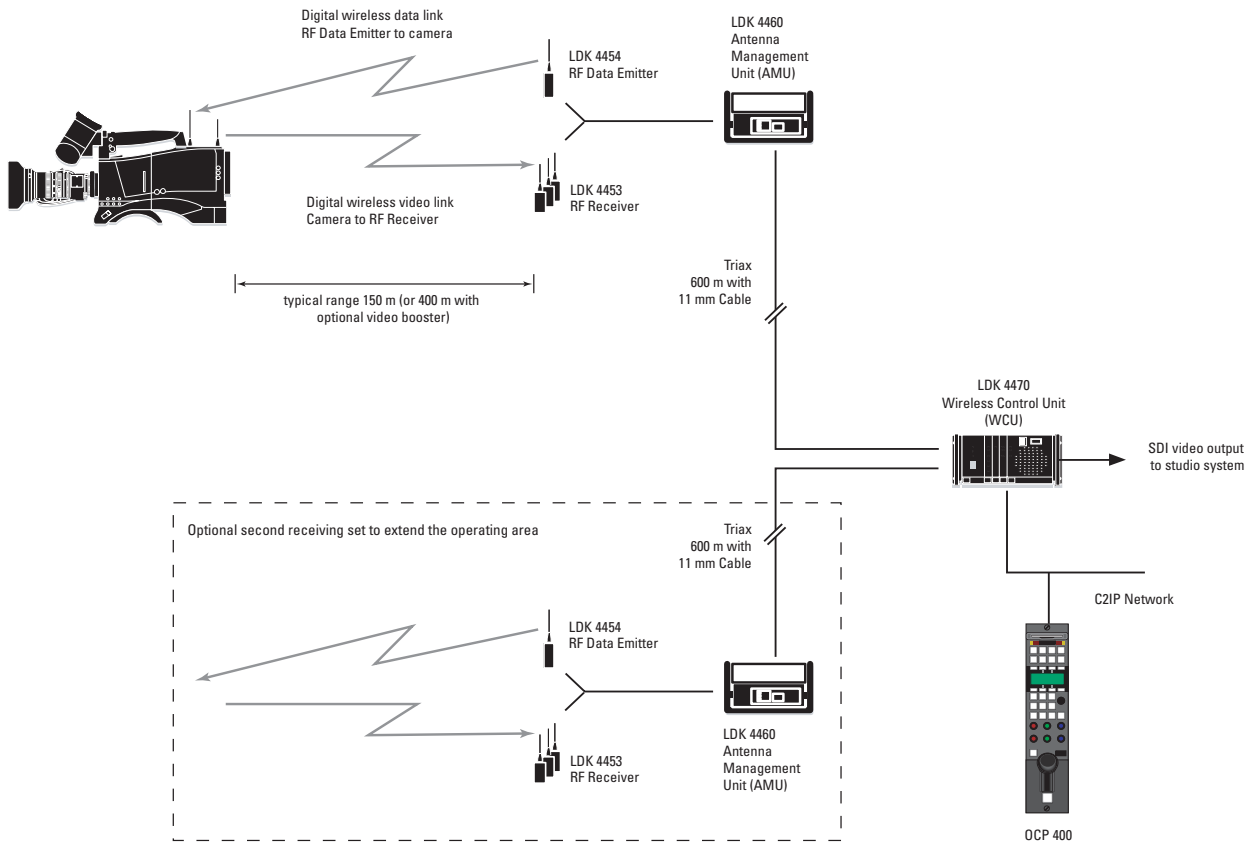

The power supply is applied to the WCU and via the Triax cable to the AMU. The camera is battery (DC) powered using high-density batteries.

The OCP 400 operational control panel is connected to the WCU using an Ethernet connection. If the OCP is connected directly to the WCU, use a crossover cable.

Triax cable

The AMU is connected to the WCU using a Triax cable. The maximum length of cable that can be used is 600 m (1,970 ft) for a 11mm Triax cable.

The approximate maximum cable lengths between an AMU and a WCU are given in the table below. Digital transmission will generate increasing bit errors and video may be lost when these lengths are exceeded. The maximum length is given for cables of the highest quality. The quality of poorer cables and the interconnections can adversely affect this maximum length.

Table 2-1. Triax cable length guide

Cable diameter	Maximum length
8 mm (0.32 in)	400 m (1,300 ft)
11 mm (0.43 in)	600 m (1,970 ft)
14 mm (0.55 in)	800 m (2,600 ft)

2.2 Wireless camera adapter (WCA)

If you decide to change frequency bands, then refer to the Appendix - Exchanging the frequency module.

Carry out the following steps to prepare the camera for use:

- Attach the adapter to the camera.
- Attach the antennas to the adapter.
- Power the camera via the adapter.

2.2.1 Attaching an adapter



Caution

Be extremely careful with the connectors between the camera head and the adapter. Do not allow the guide pins to damage the pins of the connector.

Follow these steps in the order given. Tightening or loosening the screws in the wrong order could result in mechanical damage to the camera.

To attach an adapter to the camera proceed as follow:

1. Fit the guide pin at the top rear of the camera head and the guide pins on either side of the camera connector into the corresponding slots **1** and **2** of the adapter.
2. First, tighten the two horizontal screws **3** on the top of camera.
3. Next, tighten the two horizontal screws **4** at the front of the camera.
4. Lastly, tighten the vertical screw **5** in the handle of the camera.

To detach an adapter from the camera head follow the steps for attaching it in the reverse order.

Figure 2-2. Attaching the adapter

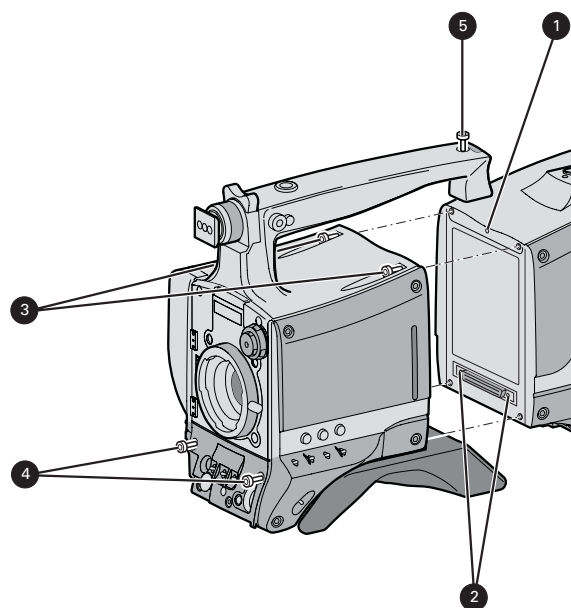

2.2.2 Attaching antennas to the adapter

The wireless camera adapter uses two different antennas: a Data link antenna and a Video link antenna. Attach both antennas securely to the wireless adapter.

Figure 2-3. Attaching the antennas

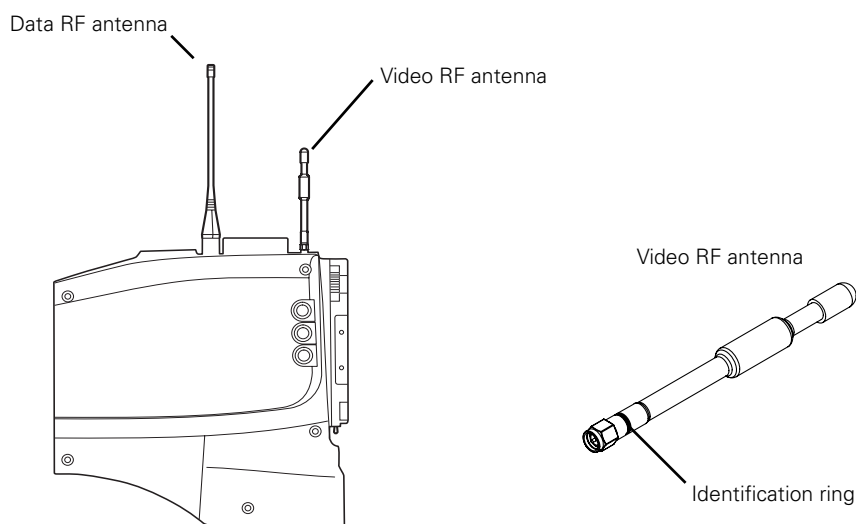

The following tables show which antenna to use for the chosen frequency ranges.

Video frequency	Identification ring
2.0 to 2.2 GHz	Black ring + code '0'
2.2 to 2.4 GHz	Red ring + code '2'
2.5 to 2.7 GHz	Green ring + code '5'

Data frequency	Antenna type
456 MHz	25814730 (length: 175 mm / 6.9 in)



Caution

Never supply power to an adapter without first ensuring that the antennas are attached.

Always use the antenna that was supplied with the frequency module. Using the wrong antenna will result in poor coverage.

Always switch off the power to the units before detaching the antennas.

2.2.3 Attaching a battery to the camera adapter

Attach a battery pack to the rear of the camera adapter or supply a +12 VDC nominal voltage to the **DC in** connector on the rear of the adapter. Due to possible high power consumption a high-density battery pack is recommended.



Caution

The input voltage at the **DC in** connector must stay between +11 VDC and +17 VDC. Always switch off the camera before removing the battery.

Figure 2-4. Camera power supply

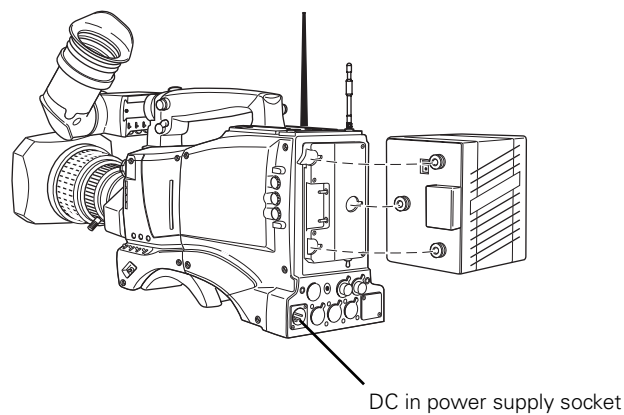

Viewfinder battery indicator

The **BATT** indicator in the viewfinder flashes when battery voltage is low. It lights continuously when battery voltage is less than 11VDC.

Figure 2-5. Battery indicator

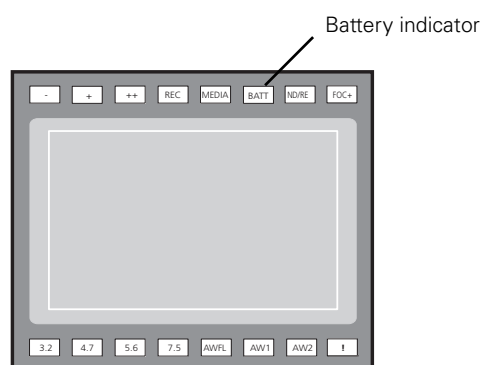

2.3 Antenna Management Unit (AMU)

2.3.1 Antenna positioning

To get the best benefits from reflections the receiving set is equipped with a three-antenna diversity system. The AMU uses the MRC (Maximum Ratio Combining) system for optimal transmission robustness. Both transmitting and receiving antennas are omni-directional, so there's no need for alignment or tracking.

Position the AMU strategically in the area you wish to cover. Preferably, mount the antenna assembly on a mast or attach it to a raised structure.

**Caution**

Always ensure that the antennas are vertical. This ensures best reception.

If required, a second AMU can be used to extend the covered area. To cover a typical stage area, it might be a good idea to place antenna assemblies upside-down at a high point on either side of the stage.

A good rule of thumb is to keep a line of sight from the camera standpoint towards the receiving antennas.

**Caution**

Always use the antennas that were supplied with the modules. Using the wrong antennas will result in poor coverage.

2.3.2 Antenna unit assembly

Set up the antenna support assembly close to the AMU as follows:

1. Unfold the antenna support assembly.
2. Attach the three antenna receiver units to the ends of the arms.
3. Attach the data emitter unit including the data booster to the centre of the assembly.
4. Screw the three antennas with SMA connector onto the antenna receiver units.
5. Connect the data antenna with BNC connector onto the data booster unit.
6. Connect the data booster SMA input to the data emitter BNC output with the supplied coaxial cable.
7. Connect the three BNC coaxial connectors of the supplied cable to the antenna receiver units.
8. Connect the 9-pin sub-D connector to the data emitter unit.
9. Connect the 2-pin LEMO connector to the data booster unit.

AMU connectors

1. Connect the three coaxial cables from the antennas to the upper row of BNC video connectors on the AMU.
2. Connect the cable from the data emitter unit to the 9-pin sub-D connector on the AMU.
3. Connect the Triax cable to the Triax output of the AMU (TRIAX output).

Figure 2-6. AMU connections

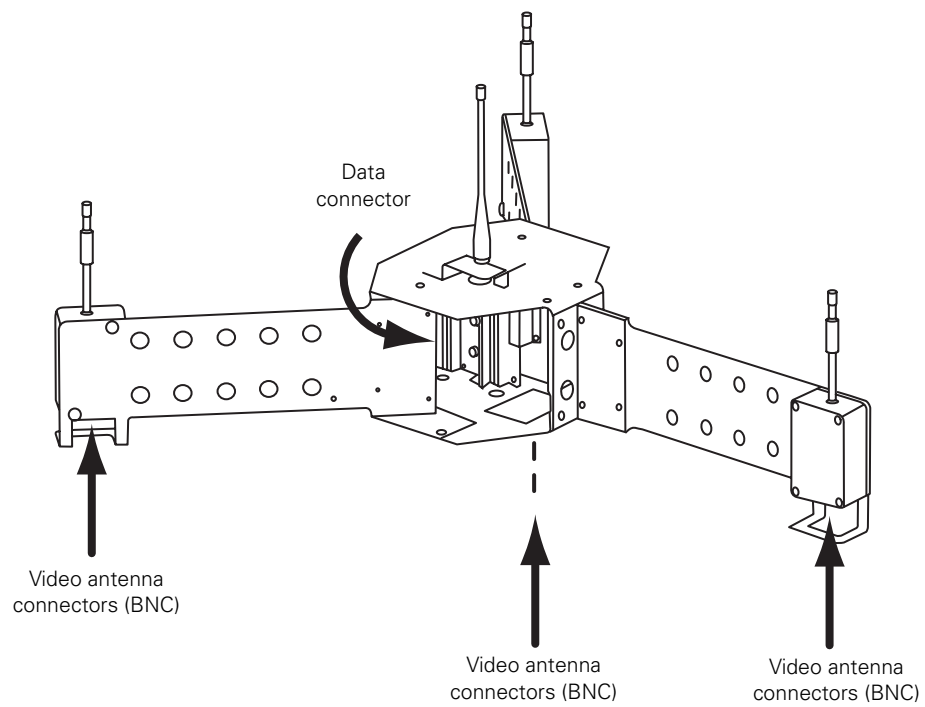

2.4 Wireless Control Unit (WCU)

An optional mounting kit is available for mounting the WCU into a standard 19-inch rack.

Connection steps:

1. Connect the triax cable from the AMU to the Triax input 1 **6** of the WCU. If you use a second AMU, connect it to Triax input 2 **7** of the WCU.
2. Connect the OCP to the C2IP network **4**. (Use the 2-wire data connector **3** for Series 9000 control units.)
3. Connect a digital monitor (SD or HD) to the SDI3 (OSD) output **9**.
4. Connect the SDI1 and SDI2 outputs **10** of the WCU to the studio system.
5. If required, provide a reference signal to the Genlock input **5** of the WCU (SD black-burst, CBVS and HD-TLS are supported). Terminate the looped-through connector with 75 Ω .
6. Connect an analog (SD) monitor to CVBS output connector 1(OSD) or 2 **8**.
7. Connect the intercom **11** system (see below).
8. Connect the signalling **12** system (see below).
9. Connect the audio **2**
10. Connect the WCU power socket **1** to the mains power supply.

Figure 2-7. WCU connections

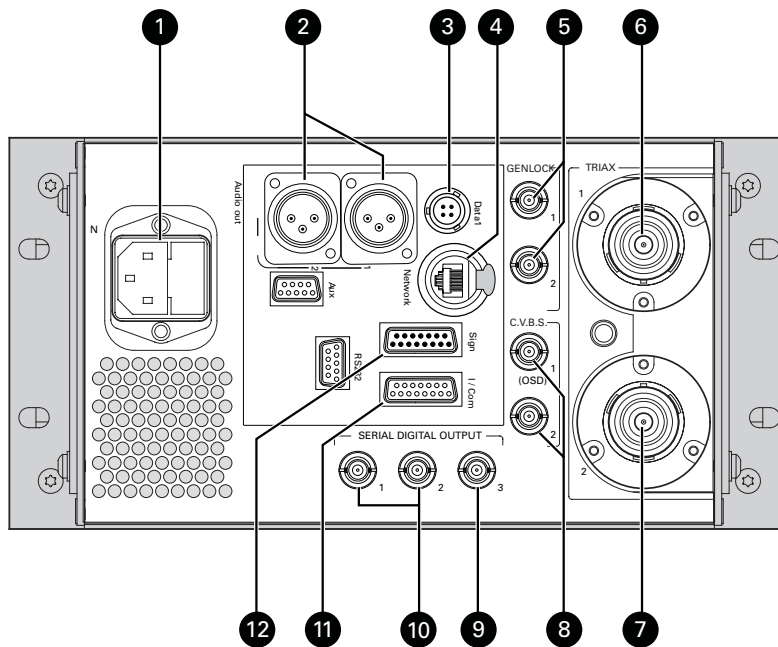

2.4.1 Connecting the studio intercom system

Connect the studio intercom system to the **I/Com** connector on the rear of the WCU. The wiring of the panel connector is shown below for two-wire and four-wire systems.

Figure 2-8. Intercom connection - two-wire system

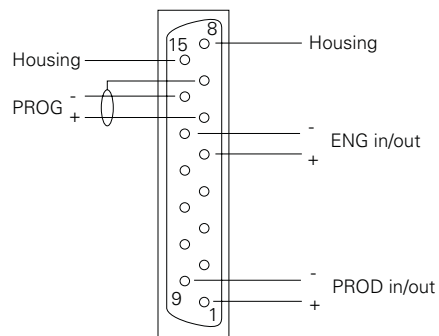

Figure 2-9. Intercom connection - four-wire system

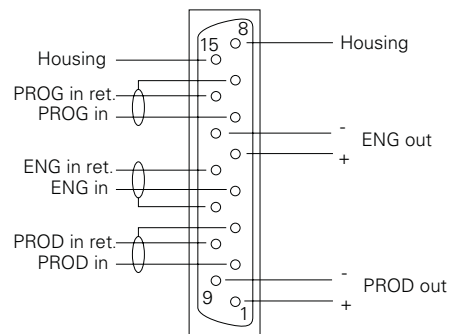

Table 2-10. Intercom signal specifications

Function	Value
4-wire	
Output signal level	+6 dBu nominal into 10 K Ω (adjustable range: +12 dBu)
Output impedance	600 Ω (max), symmetrical
Input signal reference level	+6 dBu or 0 dBu selectable
Input impedance	9 K Ω (min), symmetrical
2-wire	
Signal level	0 dBu
Load impedance	> 200 Ω
DC level	40 VDC maximum

2.4.2 Connecting the studio signalling

Connect the studio signalling system to the **Sign.** connector on the rear of the WCU. The wiring of the panel connector is shown.

Figure 2-11. Signalling connection

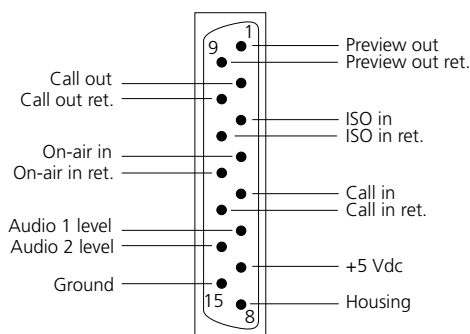

Call, On-air and Iso signals

There are four connection methods for the Call, On-air and Iso (On-air yellow) signalling functions:

1. Dry contact
2. Common ground
3. Voltage level Send lead
4. Open / voltage level Send lead

A selection in the **SYSTEM/SIGNALLING** menu allows you to make the state of the function (on or off) correspond to a particular input signal. There are two leads for each connection - Send and Return.

Table 2-12. Signalling send and return pins

Function	Send pin	Return pin
Call	2	10
Iso	3	11
On-air	4	12

The following tables show the selectable states for each of the four connection methods. The states are Open/High (OH); High/Open (HO); Low/High (LH) or High/Low (HL). Refer to Chapter 5 to see how to set these menu settings.

Dry contact

Table 2-13. Dry contact (no ground, no voltage)*

Menu setting	Input shorted	Input open
LH	Function ON	Function OFF
HL	Function OFF	Function ON

* a common return (not ground!) can be used for the three functions.

Figure 2-14. Dry contact signalling

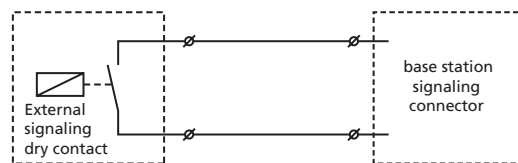

Common ground

Table 2-15. Common ground (connect one lead only to ground)*

Menu setting	Input grounded	Input open
LH	Function ON	Function OFF
HL	Function OFF	Function ON

* use either Send or Return only, do not mix.

Figure 2-16. Common ground signalling

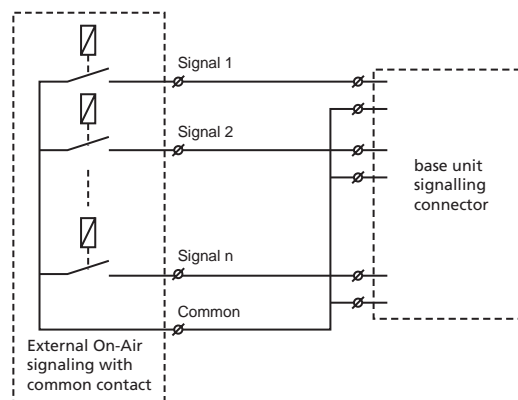

Voltage level send lead

Table 2-17. Voltage level Send lead (0 to 2.5 VDC, 4 to 24 VDC)*

Menu setting	Input 0 to 2.5 V	Input 4 to 24 V
LH	Function ON	Function OFF
HL	Function OFF	Function ON

* isolated from ground.

Open / Voltage level send lead

Table 2-18. Open / voltage level Send lead (open, 4 to 24 Vdc)*

Menu setting	Input open	Input 4 to 24 V
OH	Function ON	Function OFF
HO	Function OFF	Function ON

* isolated from ground.

Figure 2-19. Voltage level signalling

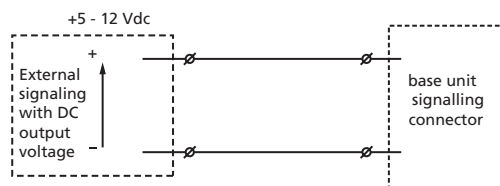

Audio levels

To control the audio gain remotely via the WCU:

1. In the camera VF menu, set the menu item `INSTALL /AUDIO / AUDIO GAIN MODE` to `EXT`.
2. Apply a DC voltage to pins 6 and 14 of the signalling connector to control the levels of audio channels 1 and 2 respectively, as shown in the figure below.

Figure 2-20. Audio level control

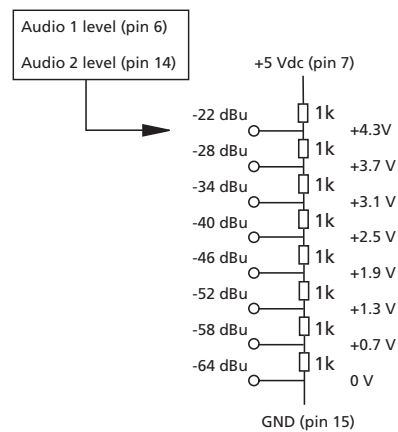

To control the audio gain locally at the camera via the VF menu:

1. Set the menu item `INSTALL /AUDIO / AUDIO GAIN MODE` to `LOC`.
2. Select the audio sources in the `INSTALL /AUDIO / AUDIO SOURCE` menu items.
3. Select the levels of audio channels 1 and 2 respectively, in the `INSTALL /AUDIO / AUDIO LEVEL` menu items.

Chapter 3

Using menus

3.1 Menu

Use the Camera and WCU menus to set up the wireless system. The menu of the WCU can be viewed by connecting a video monitor to the unit. Refer to section 5.2 for the complete contents of the WCU menu.

Refer to the User's Guide of the camera head to find out how to change the menu in your camera. Section 5.3 contains further information on the **Install** menu for the camera head when a wireless camera adapter is attached.

3.2 Setting up the WCU menu

To view the WCU menu you need to connect a digital monitor connect to the SDI (3) video output or an analog CVBS monitor to the CVBS (1) or (2) output. The text menu is superimposed on the video signal.

3.2.1 Using the rotary/push button to set up the WCU

To navigate through the WCU menu proceed as follows:

1. Loosen (manually) the two screws of the front panel marked DATA BOARD and remove the front plate.
2. Reach into the opening, push the rotary/push button at the front of the data board and then rotate it.
3. Rotate the button up or down to select the required item. The display shows the abbreviation of the current item (CA or NN).

There are two settings that can be accessed via the set-up rotary/push button on the data board:

Camera Number (CA)

When CA is displayed, push the rotary/push button to enter the selection mode. Rotate the button up or down to select an available camera number. Push the rotary/push button again to set the new camera number. The WCU automatically resets and the new camera number is shown in the display.

System Menu (NN)

When NN is displayed, push the rotary/push button twice to enter the System Menu. The rotary/push button can be used to navigate through the menu system which is displayed on the attached video monitor.

3.2.2 Using an OCP 400 to set up the WCU

An OCP can be used to set up the WCU instead of the rotary/push button.

1. Push the **Setup** button on the OCP to open the setup menu.
2. Push the selection button to choose the WCU submenu.

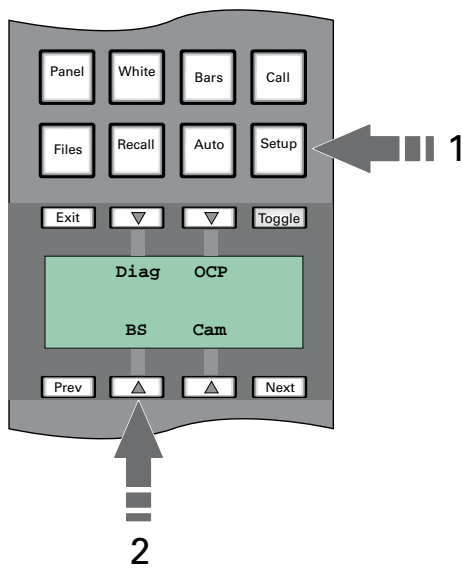

The WCU submenu appears. Use the **Next** button to view subsequent pages.

Table 3-1. WCU set-up menu

Menu	Selections	Function	Level	Possible values
WCU	MONITORING	Picture monitor selection	S	CVBS, R,G,B, Y, EXT1, EXT2, Y/EXT1, Y/EXT2
	-			
	-			
	MENU	Enable WCU internal menu	S	
<i>Next</i>	H PHASE	Adjustment H-Phase	B	0..99
	SC COARSE	Adjustment SC-Phase coarse	B	0, 90, 180, 270
	-			
	SC FINE	Adjustment SC-Phase fine	B	0..99
<i>Next</i>	NOTCH LVL	Notch depth level	B	0..99
	NOTCH	Notch enable	B	On, Off
	-			
	-			

Select the **MENU** item of the WCU menu to access the internal menu of the WCU. The internal menu appears on the WCU video text outputs.

Table 3-2. WCU internal menu

Menu	Selections	Function	Level
WCU internal menu	UP*	UP menu	S
	-		
	DOWN*	DOWN menu	S
	SELECT	Select item	S

* Or use the rotary control on the OCP to move up or down through the menu.

3.3 Navigating the WCU menus

The menu system is used for configuring the WCU. As there are a number of functions and set-up options available, it may require some time for you to become familiar with them all.

3.3.1 Entering the system menu

The system functions of the WCU are grouped into menus and sub-menus. Rotate the rotary/push button up or down to select the systems menu. The display shows the abbreviation NN. Push the rotary/push button twice to enter. The Main menu appears on the monitor.

Figure 3-3. Main menu

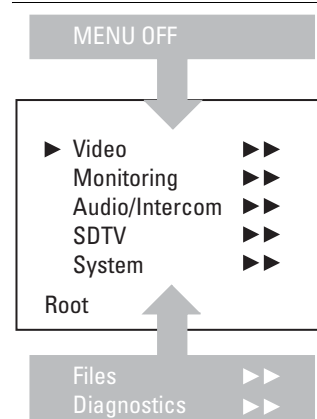

The main menu screen shows five items and the name of the menu. One more item is hidden but becomes visible when you scroll down. A cursor shows your position in the menu. The rotary/push button moves the cursor up and down.

3.3.2 Finding your way

Use the rotary/push button on the WCU to move the cursor through the menu items. If a double arrow (>>) is visible, then pressing the rotary/push button brings you one level lower in the menu system. Only five items are visible in each menu. Scroll up or down to see any additional items.

**Note**

If you are using the OCP to navigate through the menu, use the UP, DOWN and SELECT buttons or the rotary control on the OCP instead of the rotary/push button on the WCU.

When you first enter a menu (other than the main menu) the cursor is positioned next to the first item. The TOP and PREVIOUS entries are not immediately visible but are located above the first item. Use the Rotary control to scroll up to them.

- Select TOP to bring you back to the MAIN menu.
- Select PREVIOUS to go back to the menu that you were in before the current one.

Figure 3-4. System menu

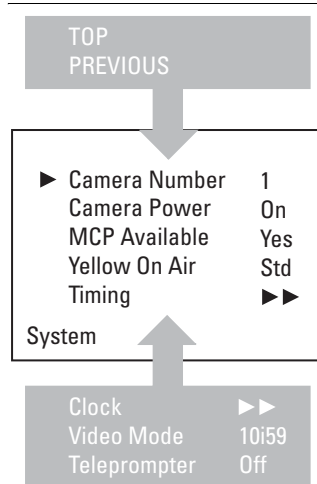

The SYSTEM menu above shows the items displayed when you first enter the menu and the other items that are available by scrolling up or down with the Rotary control.

3.3.3 Leaving the Systems Menu

If you are deep within the menu structure, follow these steps to leave:

- If necessary move the cursor to the left most column with the rotary/push button.
- Scroll upwards until the cursor points to TOP (this is the main menu).
- Press the rotary/push button. The cursor now points to the Menu Off item of the MAIN menu.
- Press the rotary/push button to leave the system menu.

This is the recommended way of leaving the system menu. The menu system disappears after a few seconds when you stop navigating. (This delay can be set in the MONITORING / MENU menu.) However, when you enter the system menu again you enter at the last position of the cursor and not at the top of main menu. To prevent confusion the next time you enter the system menu, it is advisable to leave the system menu by returning to the main menu (TOP) and selecting MENU OFF.

3.3.4 Making changes

To find out where to change a function, consult the List of System Menu Functions at the end of this section to find out under which menu group or subgroup the function is located. If the cursor points to an item (and there are no double arrows to indicate a sub-menu) then the item pointed to has a value. The value can be:

- a toggle value (only two values)
- a list value (more than two values)
- an analogue value (variable from 0 to 99)
- or unavailable (- - -).

If the value is unavailable it cannot be changed. This is indicated by three dashes (---). This can occur, for example, when a function is switched off. The analogue values associated with that function are then unavailable.

If there are only two values associated with the function, then pressing the rotary/push button toggles between these two values.

If a value is displayed next to a function that is one of several possible values, then pressing the rotary/push button places the cursor in a list menu indicating the value currently selected. Use the rotary/push button to point to a new value. Press the rotary/push button to return the cursor to the function list.

If an analogue value is displayed next to a function name, then pressing the rotary/push button places the cursor in front of the value and the rotary/push button is used to change the analogue value. Press the rotary/push button to return the cursor to the function list.

3.3.5 Using the Recall File to undo changes

If you make changes to the settings in the Systems menu and you decide not to keep them, use the Recall File function to recall a standard or stored set of values for the parameters. These files are available in the FILES menu.

Chapter 4

Setting up

4.1 Wireless Insight

The software package Wireless Insight is an electronic tool that can be used to set up the wireless camera system using a Personal Computer. It can also be used to monitor system performance during operation. The software package can be downloaded for free from the Grass valley website or obtained from your local Grass valley service representative. Refer to the help included in the software package for more details.

Use the supplied communication cable (ordering code 47233914AB) to connect Wireless Insight with the wireless camera system.

4.2 Wireless Camera Adapter (WCA)

The transmission frequencies for the video link and the data link must both be set for the Wireless Camera Adapter (WCA) and then the corresponding selections must be set on the Wireless Connection Unit (WCU). The transmission profiles must also be matched on the WCA and the WCU.

Carry out the following steps to prepare the camera for use:

- Select the video frequency via the camera menu.
- Select the data frequency via the camera menu.
- Select the transmission profiles.
- Select the camera number via the camera menu.
- Set up audio on the camera head.
- Set up intercom on the camera head.
- Set viewfinder wireless indicators.

4.2.1 Select video frequency channel

1. Decide which frequencies you wish to use. If two cameras are used at the same time, keep the largest possible distance (and at least two channels) between the selected video channels.
2. The video transmission frequency is selected in the camera head system menu. In the **Install** menu go to the **Wireless** submenu where you can select the desired frequency.

Menu path: **INSTALL > WIRELESS > VIDEOFREQ (GHZ)**

4.2.2 Select data frequency channel

1. Decide which frequencies you wish to use. If two cameras are used at the same time, keep the largest possible distance between the selected data channels.
2. The data transmission frequency is selected in the system menu of the camera head. In the **Install** menu go to the **Wireless** submenu where you can select the desired frequency.

Menu path: **INSTALL > WIRELESS > DATAFREQ (MHZ)**

4.2.3 Select transmission profiles

Three profiles are available to obtain the best possible balance between picture quality, robustness and latency. The menu paths for setting the parameters of the three profiles are:

Menu path: **INSTALL > WIRELESS > TX PROFILE > IN_OUTDOOR**

Menu path: **INSTALL > WIRELESS > TX PROFILE > Q_ROBUSTNESS**

Menu path: **INSTALL > WIRELESS > TX PROFILE > Q_LATENCY**

These profiles should be chosen for the current operating conditions and your preferences. Select the indoor or outdoor profile as appropriate.

The Q_Robustness profile allows you to balance the picture quality and the robustness of the transmission. It changes the allocated bit rate of the compression and the transmission parameters.

In_Outdoor profile	Q_Robustness profile	Description	Modulation scheme	Bitrate (Mbit/s)
Indoor	HiQ	High quality	QAM-64	66
	Std	Standard	QAM-64	50 (default)
	HiR	High robustness	QAM-16	37
Outdoor	HiQ	High quality	QAM-64	56
	Std	Standard	QAM-64	47 (default)
	HiR	High robustness	QAM-16	31



Note

The selected profiles must be the same as those selected in the WCU.

The Q_Latency profile allows you to balance the picture quality and the latency of the transmission. It takes advantage of temporal redundancy between consecutive fields. It has no influence on the transmission parameters.

Q_Latency profile	Description	Latency
Std	Standard	3 fields (default)
Q+(H)	medium latency	5 fields
Q+(V)		
Q+(T)	high latency	6 fields (720p modes) or 7 fields (1080i modes)



Note

When the transmission profiles are changed the WCU is automatically to the same profiles.

4.2.4 Select camera number

The camera number is selected in the system menu of the camera head. In the **Install** menu go to the **Wireless** submenu where you can select either the number.

Menu path: `INSTALL > WIRELESS > CAMERA NUMBER`

4.2.5 Camera head audio

Select 1 or 2 audio channels

1. The number of audio channels is selected in the system menu of the camera head. In the **Install** menu go to the Audio submenu where you can select either 1 or 2.

Menu path: `INSTALL > AUDIO > AUDIO IP MODE`

Select source audio channel 1

The audio source is selected in the system menu of the camera head. Select either the socket at the front-right of the camera, or the **Mic 1** audio channel 1 connector at the rear of the adapter.

1. In the **Install** menu go to the Audio submenu where you can select the source.

Menu path: `INSTALL > AUDIO > AUDIO 1 (2) SOURCE`

Select audio gain

1. The audio gain is set in the system menu of the camera head. In the **Install** menu go to the Audio submenu where you can set the gain for both channels.

Menu path: `INSTALL > AUDIO > AUDIO 1 (2) LEVEL`

4.2.6 Intercom

Three intercom channels – production (PROD), programme sound (PROG) and engineering (ENG) – are sent to the camera operator's headset. Intercom volume controls are on the back of the adapter. The camera operator's intercom microphone signal is sent back to the WCU.

Figure 4-1. Intercom controls on the wireless adapter

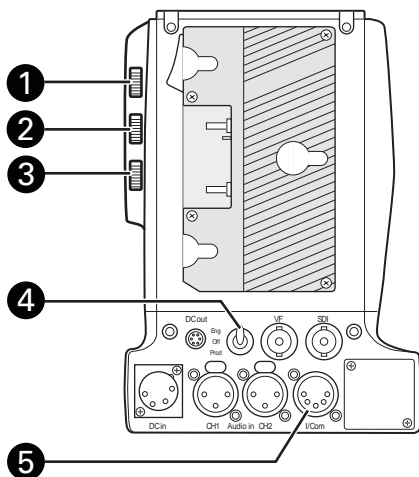

Intercom headset controls

1 Prod

Adjusts the volume of the production signal to the camera headset (when **PROD VOLUME** is set to **REAR** in the install menu).

The location of the production volume control is set in the install menu of the camera. Select either Front or Rear.

Menu path: **INSTALL > INTERCOM > PROD VOLUME**

2 Prog

Adjusts the volume of the programme signal to the camera headset.

3 Eng

Adjusts the volume of the engineering intercom signal to the camera headset.

4 Intercom microphone switch

Sends the camera operators intercom signal to either engineering (Eng) or production (Prod), or turns it off (center position). Only operates if **CAM MIC** is set to **SWITCH** in the install menu and other assigned routing switches are released.

5 Intercom headset socket

Connect the intercom headset to this XLR-5 socket.

Camera intercom menu

The **Intercom** section of the **Install** menu contains various settings for the intercom channels. Intercom microphone amplification levels, phantom power supply and microphone on/off switches are also available in this menu.

Intercom microphone routing

Assignable buttons on the camera can also be set to select either ENG or PROD. These buttons override the Intercom Microphone switch on the back of the WCA.

When the **INSTALL > INTERCOM > CAM MIC** item of the camera menu is set to OFF, the Intercom Microphone switch on the back of the WCA is disabled.

4.2.7 Viewfinder indications

Check QoS LED (data)

1. In the camera viewfinder check the ! indicator that indicates the quality of service (QoS) of the data signal: Off is OK, flashing is critical.

Select cell number for display

1. In a dual AMU system it can be useful to see which AMU is being used by the camera. The cell number of the AMU currently in use can be displayed in the bottom left corner of the viewfinder.
2. The display of the cell number in the viewfinder is selected in the camera head menu. In the VF menu go to the Box DownRight item where you can select **CELL**.

Menu path: **VF > BOX DOWNRIGHT**

4.3 Antenna Management Unit (AMU)

4.3.1 AMU indicators

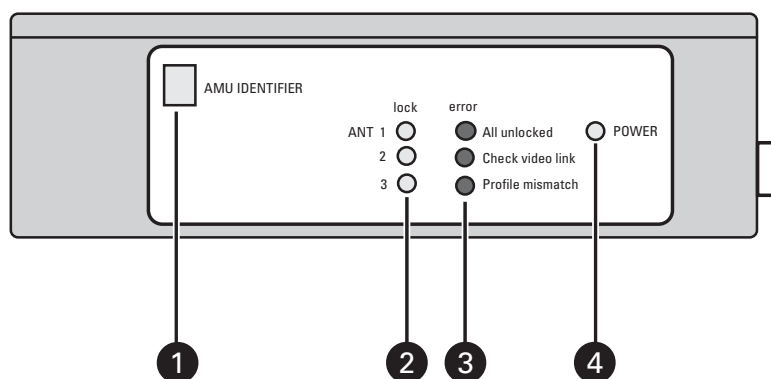

1 AMU IDENTIFIER

The display shows the number of the AMU (to identify AMUs when there are two AMUs in a system). This number also appears in the viewfinder at the bottom right.

2 Lock LEDs

These three green indicators, whose numbers correspond to the three transmission antennas, light to indicate that there is a good synchronization between camera and the specific AMU antenna. At least one of these indicators must be lit to have a connection. If all three are lit, the RF link is at its strongest.

If all three indicators are not lit then none of the three antennas received a signal that could allow synchronization. Possible causes are:

- camera signal is absent, or
- an incorrect frequency is being used.

3 Error LEDs

These three red indicators light to indicate different problems in the connection between the camera and a specific AMU antenna.

Check Video Link: even if one antenna picks up a signal, the digital demodulation process could not correct all transmissions errors. Video loss will occur. Possible causes are:

- camera signal is too weak, or
- signal is polluted by strong interference

Profile Mismatch : Transmission profile (In/Outdoor and Q-Robustness) selection in the VF menu and WCU menu are not the same.

4 POWER LED

This indicator lights when power from the WCU is supplied to the AMU via the triax cable.

4.3.2 Selecting AMU identifier

If more than one AMU is used in a dual AMU system, each AMU must be given a unique identification number. The AMU identification number is shown on the upper display on the side of the AMU. Proceed as follows:



Caution

Ensure power is disconnected before proceeding.

1. Open the AMU by removing the four screws underneath the sun cover and tilt open the lid of the case.
2. Find the row of three rotary switches on the main print panel.
3. Set the rotary switch CW1 to the cell number you want for the AMU.
4. Close the lid and tighten the screws carefully.

Figure 4-2. AMU cell identification number

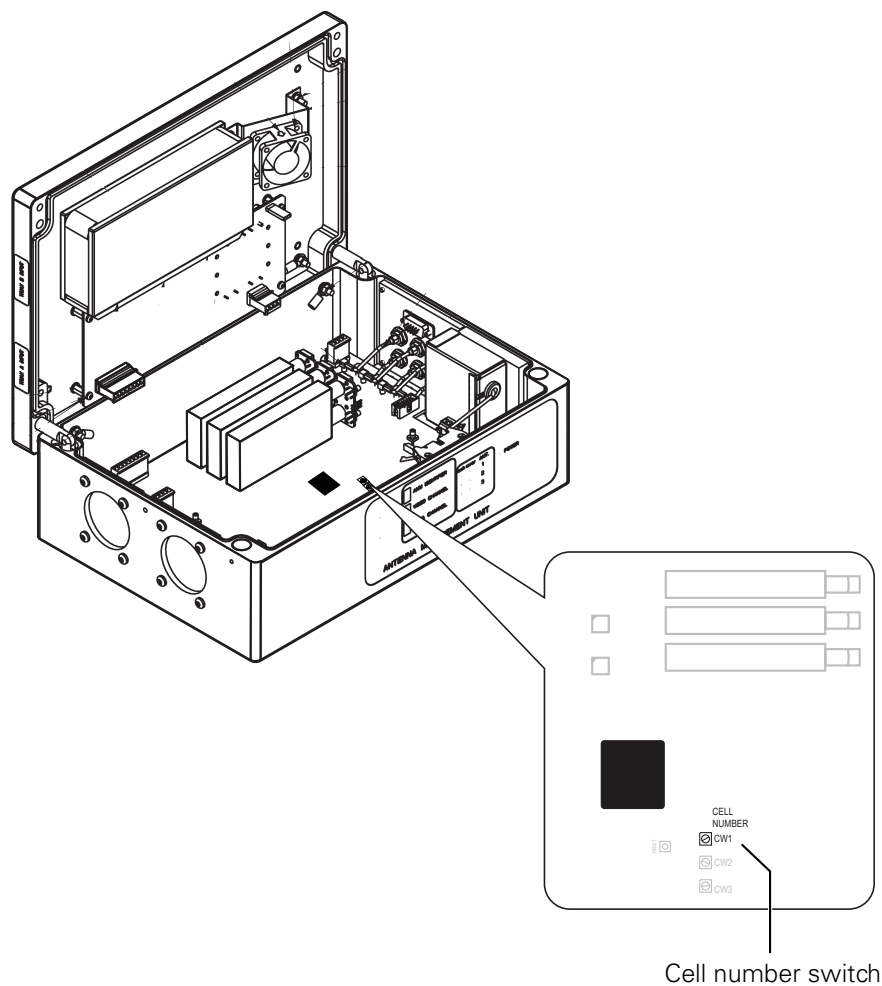

4.4 Wireless Control Unit (WCU)

4.4.1 Select a video acquisition mode

The video mode for the camera head is set in the WCU **System** menu. The mode set here overrides the mode set in the camera when a connection is established.

Menu path: `SYSTEM > VIDEOMODE`



Note

The video mode menu item is only shown when there is no connection with the camera head.

4.4.2 Set transmission frequencies

1. Select video transmission frequency in steps of 1 MHz.

Menu path: `SYSTEM > TX PARAM > VIDEO_FREQ`

2. Select data transmission frequency in steps of 50 kHz.

Menu path: `SYSTEM > TX PARAM > DATA_FREQ`



Note

The frequencies selected must be the same as those selected in the camera head.

4.4.3 Set transmission profiles

In the WCU System menu, set the same transmission parameters that you selected for the three profiles in the camera head:

Menu path: `SYSTEM > TX PARAM > IN_OUTDOOR`

Menu path: `SYSTEM > TX PARAM > Q_ROBUSTNESS`

Menu path: `SYSTEM > TX PARAM > Q_LATENCY`



Note

The selected `IN_OUTDOOR` and `Q_ROBUSTNESS` parameters must be the same as those selected in the camera head. When you change the profiles in the WCU the WCA is automatically updated.

4.4.4 Select camera number

The camera number selected must be the same as that selected in the camera head. In the **System** menu go to the **Camera number** submenu where you can select the number.

Menu path: `SYSTEM > CAMERA_NUMBER`

4.4.5 WCU audio menu

Select audio output level and delay

1. Set the audio output level to enable (+6 dB) or disable (0 dB).
2. The audio delay function delays the audio signal so that it is synchronised with the video signal.

4.4.6 WCU intercom menu

Select a 2-wire or a 4-wire system

1. Depending on the intercom wiring set the wire mode for the Eng and Prod intercom channels to 2wires or 4wires.

Menu path: AUDIO_INTCOM > INTERCOM > ENG > WIRE MODE

Menu path: AUDIO_INTCOM > INTERCOM > PROD > WIRE MODE

Select channel input level

1. For each intercom channel you can enable (+6 dB) or disable (0 dB) the level.

Menu path: AUDIO_INTCOM > INTERCOM > ENG > LEVEL

Menu path: AUDIO_INTCOM > INTERCOM > PROD > LEVEL

Menu path: AUDIO_INTCOM > INTERCOM > PROD > LEVEL

Select intercom output level

1. Adjust the output level as required.

Menu path: AUDIO_INTCOM > INTERCOM > ENG (PROD) > OUT REF LEVEL

Adjust 2-wire balance

1. Set local side tone in the camera to zero.
VF menu path: INSTALL > INTERCOM > SIDE TONE
2. Adjust the output level to minimize the feedback from the headset microphone to the headset muff.
WCU menu path: AUDIO_INTCOM > INTERCOM > ENG (PROD) > 2W BALANCE
3. Reset the local side tone in the camera to a comfortable value.

4.4.7 Signalling

1. On Air signalling configuration
2. Call input configuration

4.4.8 WCU controls and indicators

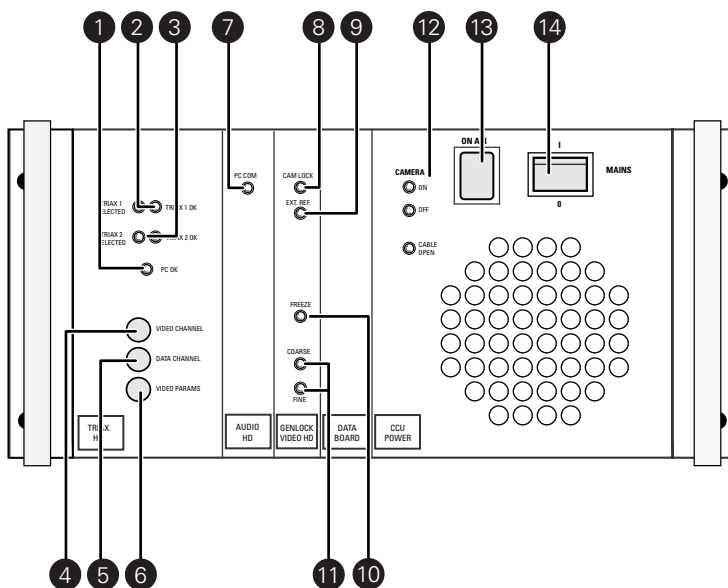

1 PC OK

When a remote PC is connected to the front plug of the WCU Audio Board, this LED lights to indicate the status of the connection. When no PC is connected, it lights to indicate an internal fault.

PC OK (Green)	PC connected	Message
Off	No	Internal switch configuration is OK.
Flashing	No	Internal switch configuration is not OK.
Toggling	Yes	Dialog busy. Toggling indicates transfer speed.

2 TRIAX 1 SELECTED

Reflects the status of roaming (AMU1/AMU2) and AMU under control of WCU.

Triax Sel. (Orange)	Message
On	This triax input is selected by the roaming.
Flashing (~5/s)	AMU is not acknowledging control data sent by WCU.
Off	Triax link (AMU ->WCU) is not OK or AMU is not connected.

TRIAX 1 OK

Reflects the status of the Triax link (AMU -> WCU) and checks for video content.

Triax OK. (Green)	Message
On	Triax link (AMU -> WCU) is OK, video content delivered by AMU is OK.
Flashing (~1/s)	Triax link (AMU -> WCU) is OK, no video content delivered by AMU.
Off	Triax link (AMU -> WCU) is not OK or AMU is not connected.

Triax Sel. (Orange)	Triax OK (Green)	Message
On	On	Triax input is selected. Video transmission in Triax is OK.
Off	On	Triax input is not selected. Video transmission in Triax is OK.
Flashing (~5/s)	-	AMU is not acknowledging control data sent by WCU.
-	Flashing (~1/s)	Triax link (AMU -> WCU) is OK, no video content delivered by AMU.
On	Off	Video transmission in Triax is not OK.

3 TRIAX 2 OK / SELECTED

These indicators operate in the same way as for Triax input 1 above.

4 VIDEO CHANNEL (rotary switch not used)**5 DATA CHANNEL (rotary switch not used)****6 VIDEO PARAMS (rotary switch not used)****7 PC COM**

Connector for attaching a PC to the WCU.

8 CAM LOCK

Reflects the status of the internal genlock (Camera/WCU).

Cam Lock (Green)	Message
On	Camera is locked on WCU.
Off	Camera is not locked on WCU (check data link).

9 EXT REF

When ON this light indicates the presence of a correct external sync signal on the GEN LOCK connector of the WCU. Otherwise it is off or flashing.

Reflects the status of the internal genlock (Camera/WCU).

Cam Lock (Green)	Message
On	Studio reference signal is detected and is consistent with the selected video mode.
Off	Studio reference signal is not detected (WCU is free running).
Flashing (~5/s)	Studio reference signal is detected but is not consistent with the selected video mode (WCU is not locked on studio).

10 FREEZE

When ON, this light indicates that Freeze Mode is activated due to an interrupted video connection.

11 HORIZONTAL PHASE (not used)**12 CAMERA**

ON

Normally and permanently ON, this light indicates that the WCU is powered. This indicator flashes to indicate excessive consumption at the WCU.

OFF

This indicator lights when the AMU is not drawing power. This indicator flashes to indicate that the AMU power consumption is excessively low (< 26 W).

CABLE OPEN

This normally OFF indicator lights if there is no Digital Triax Rack in the WCU.

13 ON AIR

When ON, this light indicates that the camera signal is on air (ON AIR1).

14 MAINS

The equipment master on/off switch:

«I»: The equipment is operating.

«O»: The equipment is not operating.

Chapter 5

Menu contents

5.1 Wireless Control Unit menu structure

Access to the functions on these menus is determined by the user level that has been set. The menus are as follows:

Video menu

The video menu contains functions for configuring video outputs and freeze mode.

Monitoring menu

This menu contains the functions which determine how items in the menus are displayed on the monitoring outputs.

Audio/Intercom menu

The functions contained under this menu control various aspects of audio and intercom.

SDTV menu

The functions contained under this menu are used for the SDTV outputs.

System menu

This menu contains the functions that are used to set up the general configuration and for carrying out adjustments and calibrations of the WCU.

Files menu

This menu allows values to be stored in System and operator files, and allows these files to be recalled as required.

Diagnostic menu

The diagnostic menu is designed to provide information on the current status of the WCU.

5.1.1 WCU user levels

Access to the functions on these menus is determined by the user level that has been set. The menu items are divided into two user levels. The operator level **Oper** is default accessible. Menu items with user level **Install** are only accessible if the menu level is set to Install. To enter the Install level proceed as follows:

1. Enter the menu.
2. Navigate to the Monitoring \ Menu \ Menu level Item.
3. Set the Menu level to Inst.

The purpose of the user levels is to restrict the set of functions which can be changed by whoever is using the WCU. In this way the danger of the operator accidentally changing critical functions while shooting is reduced. The user level automatically reverts to **Oper** when menu **Off** is executed (either after time out or user's choice).

5.2 WCU menu contents

In the values column, the default value of the item is shown in **bold**.

5.2.1 WCU Video menu

Menu item	Values	Description	Level	File
SDI 1 & 2	SD, HD	Select video standard for SDI outputs 1 and 2. When SD is selected, the menu text is superimposed on SDI 1 and SDI 2 signals.	Install	-
SDI 3	SD, HD	Select the video standard for SDI 3. The menu text is superimposed on the video signal.	Install	-
Freeze Mode	No, Field	Set freeze frame mode when loss of signal occurs.	Install	-
Colour bar	On, Off	Switch colour bar in the camera head on or off.	Oper	-

5.2.2 WCU Monitoring menu

Menu item	Values	Description	Level	File
Menu			Oper	
Display	On, Time	Selects menu display time: On = permanently displayed; Time = menu switches off after a set time.	Oper	-
Menu Time	5..99 (10)	Selects the length of time the menu is displayed.	Oper	-
Menu OnAir	Ena , Dis	When Enabled, the WCU menu can be visible on the video outputs, even when the system is On Air. When Disabled, the WCU menu will never be shown on the video outputs when the system is On Air.	Install	-
Menu Level	Oper , Inst	Selects the menu access level.	Oper	-
Service mode	exec	Confirms and enters the service level.	Install	-
Statusbar			Oper	-
Studio			Oper	-
Studio	On, Off	Display the studio name in the status bar	Oper	-
Name	<Text>	Edit the studio name	Oper	-
Operator			Oper	-
Studio	On, Off	Display the camera operator's name in the status bar	Oper	-
Name	<Text>	Edit the camera operator's name	Oper	-
Cam number	On, Off	Display the camera number in the status bar	Oper	-

5.2.3 WCU Audio/Intercom menu

Menu item	Values	Description	Level	File
Audio				
Delay	On, Off	Turns audio delay on or off. When turned on, it compensates for perfect lip sync at the WCU outputs.	Install	-
Audio Out1 Level	0dB, +6dB	Audio 1 output level	Install	-
Audio Out2 Level	0dB, +6dB	Audio 2 output level	Install	-
Mode	Single, Dual	Selects single (mono) or dual (stereo) audio channel transport.	Install	-
InterCom				
Eng				
Wire Mode	2wires, 4wires	Set studio intercom wiring mode for Engineering channel	Install	-
2w_Balance	0..99 (50)	Set 2-wire intercom balance	Install	-
Level	0dBu, +6dBu	Set intercom channel input level	Install	-
Out Ref Level	0..99 (50)	Set output reference level	Install	-
Prod				
Wire Mode	2wires, 4wires	Set studio intercom wiring mode for Engineering channel	Install	-
2w_Balance	0..99 (50)	Set 2-wire intercom balance	Install	-
Level	0dBu, +6dBu	Set intercom channel input level	Install	-
Out Ref Level	0..99 (50)	Set output reference level	Install	-
Prog				
Level	0dBu, +6dBu	Set intercom channel input level	Install	-
Isolate	Isolate, System	Isolate = isolate Prog and Prod intercom channels from Eng, System = isolate Off	Install	-
1kHz Tone	On, Off	Switch test tone on or off	Install	-
Compander	On, Off	Switch compander on or off	Install	-

5.2.4 WCU SDTV menu

Menu item	Values	Description	Level	File
Detail				
Detail	On, Off	Switch horizontal detail on SDTV outputs on or off.	Oper	-
Level	0..99 (50)	Sets horizontal detail level on SDTV outputs.	Oper	-

5.2.5 WCU System menu

Menu item	Values	Description	Level	File
Camera Number	0..99 (1)	Camera number	Oper	-
ControlMode	C2IP, S9000	Select Camera Control system	Oper	-
IP address				
IP Config Mode	Auto, Manual		Oper	
IP Digit 1	0..255		Oper	
IP Digit 2	0..255		Oper	
IP Digit 3	0..255		Oper	
IP Digit 4	0..255		Oper	
Subnet mask	0..255		Oper	
Apply IP settings	exec			
Ethernet				
Signalling				
Timing				
Clock				
VideoMode	720p50, 720p59, 1080i50, 1080i59			
Wireless				
MOD802.16 Test				
VideoFreqRangeSelect				
VideoFreqRange				
VideoFrequency				
DataFreqRange				
DataFrequency				

Menu item	Values	Description	Level	File

5.2.6 WCU System menu

MENU	VALUES	DESCRIPTION	LEVEL	FILE
Camera Number	0..99 (1)	Camera number	oper	-
ControlMode	C2IP, S9000	Select Camera Control system	oper	-
IP Address				
IP Config Mode	Auto, Manual	IP address configuration	oper	-
IP Digit 1	0..255		oper	-
IP Digit 2	0..255		oper	-
IP Digit 3	0..255		oper	-
IP Digit 4	0..255		oper	-
Subnet mask	0..255		-	-
Apply IP settings	exec		-	-
Ethernet				
Ethernet Speed	10Mb, 100Mb, Auto		install	-
Ethernet Duplex	Half, Full, Auto		install	-
Signalling				
Yellow On Air	Standard, Independant	Signal method	oper	-
Yellow On/Off	Low/High, High/Low, Open/High, High/Open	Signal method	oper	-
OnAir On/Off	Low/High, High/Low, Open/High, High/Open	Signal method	oper	-
Call On/Off	Low/High, High/Low, Open/High, High/Open	Signal method	oper	-
Timing				
H Phase Coarse	-6 .. +1uS (1uS steps)	Coarse horizontal phase for both SD and HD outputs	oper	-
HD H Phase Fine	0..99 (50) HD pixel steps	Fine horizontal phase for both HD outputs	oper	-
SD H Phase Fine	0..99 (50) SD pixel steps	Fine horizontal phase for both SD outputs	install	-
Clock				
Day	1..31	Set the value for Day	install	-
Month	1..12	Set the value for Month	install	-
Year	0..99	Set the value for Year	install	-
Hour	0..23	Set the value for Hour	install	-
Minutes	0..59	Set the value for Minutes	install	-
VideoMode	720p50, 720p59, 1080i50, 1080i59	Video mode if the camera is not connected	install	

MENU	VALUES	DESCRIPTION	LEVEL	FILE
Wireless				
MOD802.16 Test	On, Off	Turns MOD802.16 test on or off	service	-
VideoFreqRangeSelect	Auto manual	Selects video frequency range.	install	-
VideoFreqRange	2.0-2.2 , 2.2-2.4, 2.4-2.5, 2.5-2.7, 2.7-2.9	Selects video frequency range.	install	-
VideoFrequency	2.xxx .. 2.yyy GHz	Selects video frequency (within the selected range) in 1 MHz steps.	install	-
DataFreqRange	454 . .462 MHz	Selects data frequency range. Note: this setting is always 454-462 MHz.	install	-
DataFrequency	4xx.xx .. 4yy.yy	Selects data frequency in 50 kHz steps.	install	-
RX profile				
In_Outdoor	Indoor , Outdoor	Selects environment profile.	install	-
Q_Robustness	HiQ, Std , HiR	Selects quality/robustness trade-off. HiQ = high quality; Std = standard; HiR = high robustness.	install	-
Q_Latency	Std , Q+(H), Q+(V), Q+(T)	Selects quality/latency trade-off. Std = standard low latency; Q+(H), Q+(V) medium latency; Q+(T) high latency.	install	-
TempUnit	C , F	Temperature indication unit	install	

5.2.7 WCU Files menu

MENU	VALUES	DESCRIPTION	LEVEL	FILE
User Operator Files				
Operator File	1..4	Select operator file	oper	-
Recall	exec	Recall the selected operator file	oper	-
Store	exec	Store the selected operator file	oper	-
Std. Operator Files				
Operator File	Cust , Fact		oper	-
Recall	exec		oper	-
Store	exec		oper	-
User System Files				
Operator File	1..4		install	-
Recall	exec		install	-
Store	exec		install	-
Std. System Files				
Operator File	Cust , Fact		install	-
Recall	exec		install	-
Store	exec		install	-

5.2.8 WCU Diagnostics menu

MENU	VALUES	DESCRIPTION	LEVEL	FILE
Error Event logging				
Fatal software	-		service	-
Non-Fatal software	-		service	-
Unexpected software	-		service	-
Fatal System	-		service	-
Non-Fatal System	-		service	-
Erase All Erase Events	-		service	-
Board ID				
Data Board	[ID]		oper	-
Board Diagnostics				
Data Board	[value]		oper	-
Communication Diag				
Camera connected	exec		oper	-
OCP connected	exec		oper	-
MCP connected	exec		oper	-
C2IP Panels	exec		oper	-

5.3 Camera (LDK 8000) install menu for WCA

Only the WCA install menus are expanded in this table. Refer to the user's guide of your HD camera for detailed information on the other menu items.

Install	Values	Description	Level	File
Video mode				
Disable Camera				
Intercom >>				
Audio >>				
Tally >>				
Reverse Scan >>				
Exposure >>				
Gain Preset >>				
AutoWhite >>				
Timing >>				
Private Data				
PCI id				
Buttons >>				
Fan Operation >>				
Wireless			User 3	
Camera number	0..99 (1)	Selects camera number.	User 1	Oper
Data Freq. MHz	454.00 .. 462.00 MHz	Selects data frequency in 50 kHz steps.	User 3	-
Video Freq. GHz	2.203 .. 2.398 GHz or 2.503 .. 2.683 GHz	Selects video frequency (within the selected range) in 1 MHz steps.	User 3	-
Ext. Boost Adjust	0..12 (0)	Sets the RF power attenuation for the external video booster. With each increment of 2, power level is decreased by 1 dB.	User 3	-
Tx Profile			User 3	
In/Outdoor	Indoor, Outdoor	Selects environment profile	User 3	-
Q_Robustness	HiQ, Std, HiR	Selects HiQ = high quality; Std = standard; HiR = high robustness.	User 3	-
Q_Latency	Std, Q+(H)/Q+(V), Q+(T)	Selects quality/latency trade-off. Std = standard low latency; Q+(H), Q+(V) = medium latency; Q+(T) = high latency.	User 3	-

Chapter 6

Connectors

6.1 WCA connectors

Figure 6-1. WCA connector location

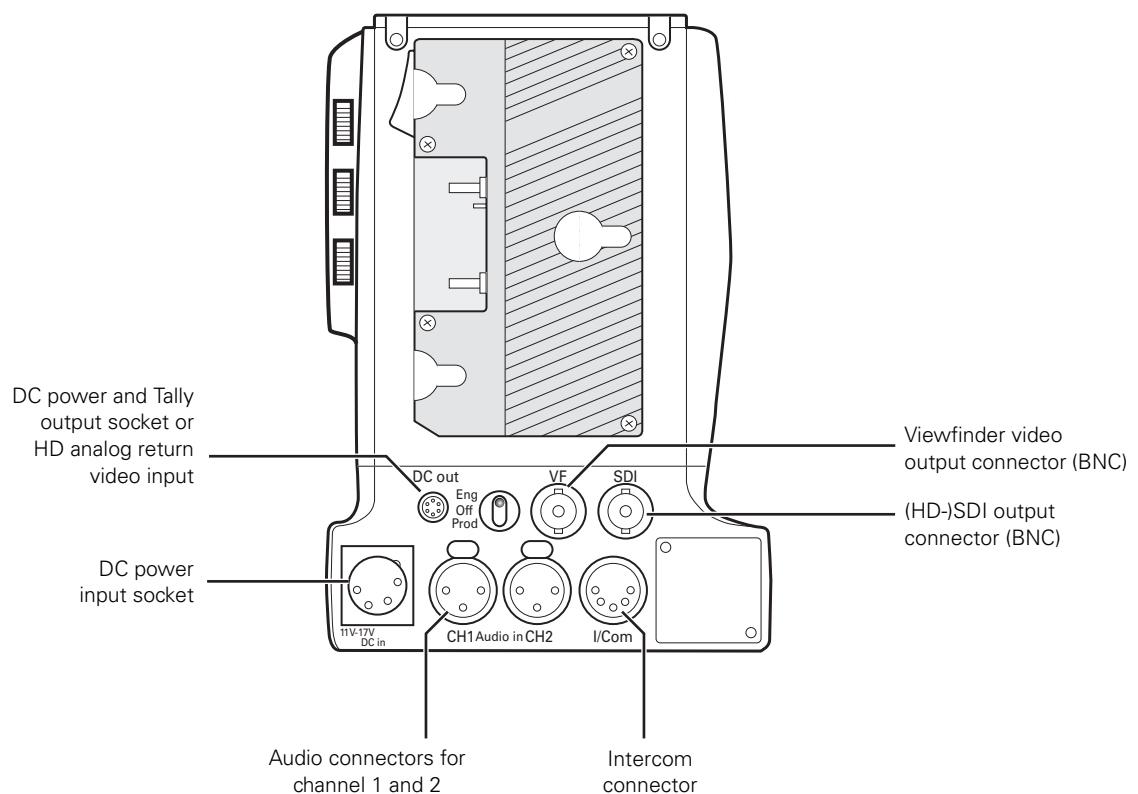

6.1.1 Viewfinder video output connector

Figure 6-1. Viewfinder video output connector

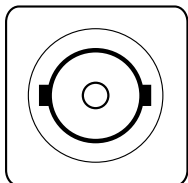

BNC connector: panel view (X107)

This socket provides an analog 1.0 Vpp output viewfinder HD video signal from the WCA.

Text overlay is provided on this output signal.

6.1.2 HD - SDI connector

Figure 6-2. HD - SDI connector

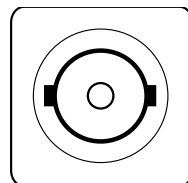

BNC connector: panel view (X105)

This socket is used to output the camera HD-SDI video signal according to SMPTE 292M.

No text overlay available.

6.1.3 Audio microphone 1 connector

Figure 6-3. Audio microphone 1 connector

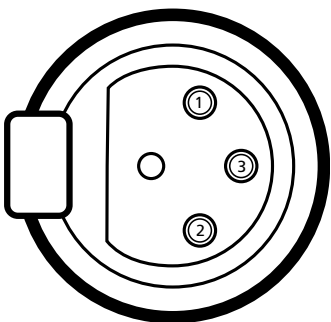

XLR 3-pole female; panel view (X102)

1. Audio Screen
2. Audio In
3. Audio Return

Input impedance > 10 K Ω
Phantom power +48V switchable
Sensitivity range microphone: -64 to -22 dBu
(or 0 dBu for line)

6.1.4 Audio microphone 2 connector

Figure 6-4. Audio microphone 2 connector

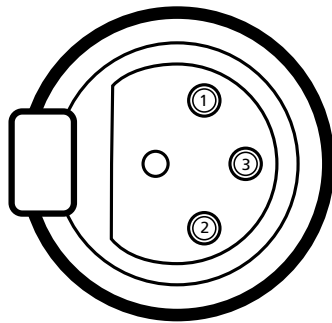

XLR 3-pole female; panel view (X103)

1. Audio Screen
2. Audio In
3. Audio Return

Input impedance > 10 K Ω
 Phantom power +48V switchable
 Sensitivity range microphone: -64 to -22 dBu
 (or 0 dBu for line)

6.1.5 Intercom headset connector

Figure 6-5. XLR intercom headset connector

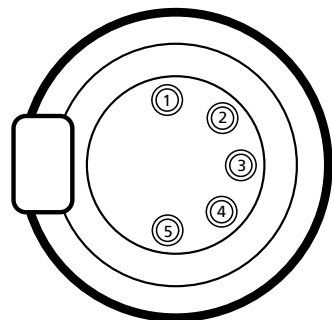

XLR 5-pole female; panel view (X104)

1. Microphone return
2. Microphone
3. Telephone return
4. Telephone left
5. Telephone right

Microphone level: -44 dBu / -24 dBu switchable
 Microphone input impedance: >10 K Ω switchable
 phantom power +12V

Output level: +12 dBu max
 Output impedance: <50 Ω

6.1.6 DC power input socket



Caution

The input voltage must not exceed +17 Vdc.

Figure 6-6. DC power input connector

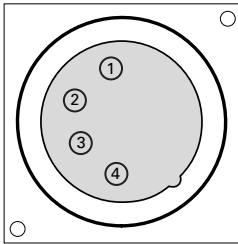

XLR 4-pin male: panel view

1. GND
2. Not connected
3. Not connected
4. +11 V DC to +17 VDC

This socket accepts a DC voltage of 15 VDC nominal.

6.1.7 DC power and tally output connector

Figure 6-7. DC power and tally output connector

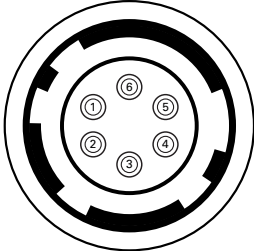

Hirose 6-pin female (panel view)

Manufacturer part numbers:
chassis: Hirose HR10A-7R-6S (female)
cable: Hirose HR10A-7P-6P (male)

1. GND (video)
2. Video input (1.0 Vpp CVBS)
3. DC out (+11 V DC to +17 VDC) 1.5 A max.
4. GND (DC)
5. Not connected
6. Tally signal (current must be limited to 10 mA)

Shield of cable directly to the connector housing.

The socket provides access to an internal tally switch. When the camera is on-air, a logic high level (LVT typ. 2.2 V) will source current into an external tally indicator connected between pin 4 (Ground) and pin 6. User MUST limit the current to 10 mA max.

6.2 AMU connectors

Figure 6-2. AMU connector location

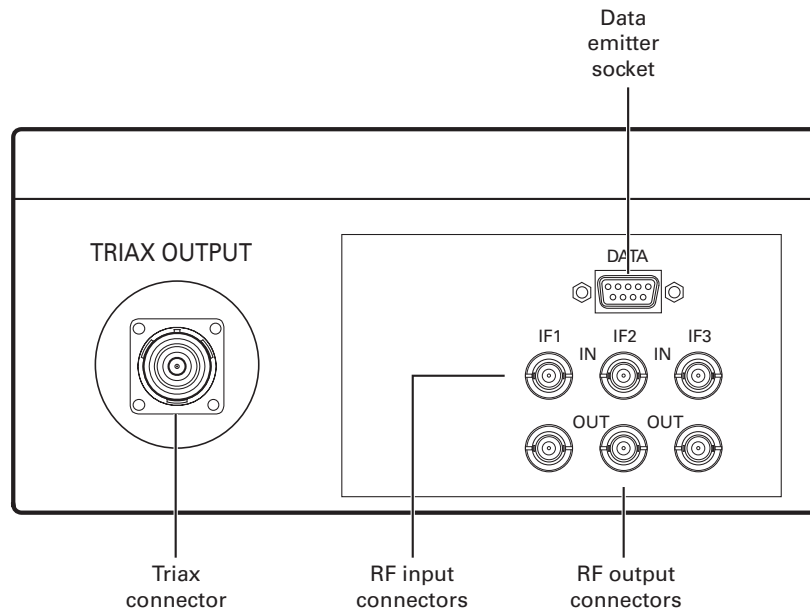

6.2.1 Triax connector

Figure 6-8. Triax connector

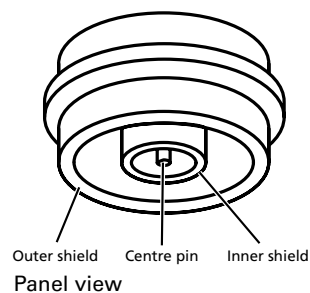

1. Centre pin: Power and signals
2. Inner shield: Return
3. Outer shield: Housing GND

This socket is used to connect the triax cable to the triax input of the WCU. Receptacle types: Fischer, Tri-lock, ARD, Lemo 4, Lemo BBC, Lemo 3.

6.2.2 Data emitter socket (DATA)

Figure 6-9. Data emitter socket

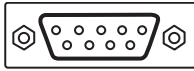

9-pin sub-D: panel view

This socket is used to connect the AMU to the data emitter unit of the antenna assembly.

1. GND
2. GND

Data emitter configuration SPI bus (RS232 levels ~ $\pm 10V$)

3. SPI_SCK(output)
4. SPI_MOSI(output)
5. SPI_MISO(input)
6. SPI_SS(output)

Data emitter Tx Data (RS232 levels ~ $\pm 10 V$)

7. DATA (output)
8. + 12Vdc
9. + 12Vdc

6.2.3 RF receiver connectors (UHF IN)

Figure 6-10. BNC RF input connectors

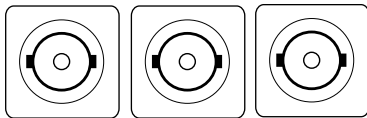

BNC connector: panel view

These sockets are used to connect the AMU to the antenna receiver units of the antenna assembly.

Always use 75 Ω cables. Phantom power of +9 V is always switched on.

6.2.4 RF receiver connectors (UHF OUT)

Figure 6-11. BNC RF output measurement connectors

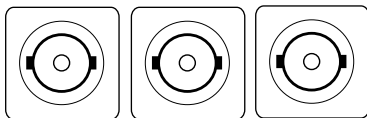

BNC connector: panel view

These sockets are for measurement purposes only. Use short 75 Ω cables only for measuring equipment.

Caution: The RF gain between UHF In and UHF out depends on UHF In power:

- ~ +3 dB for UHF In power < ~ -45 dBm
- ~ -15 dB for UHF In power > ~ -45 dBm

6.3 WCU connectors

Figure 6-3. Back of the WCU

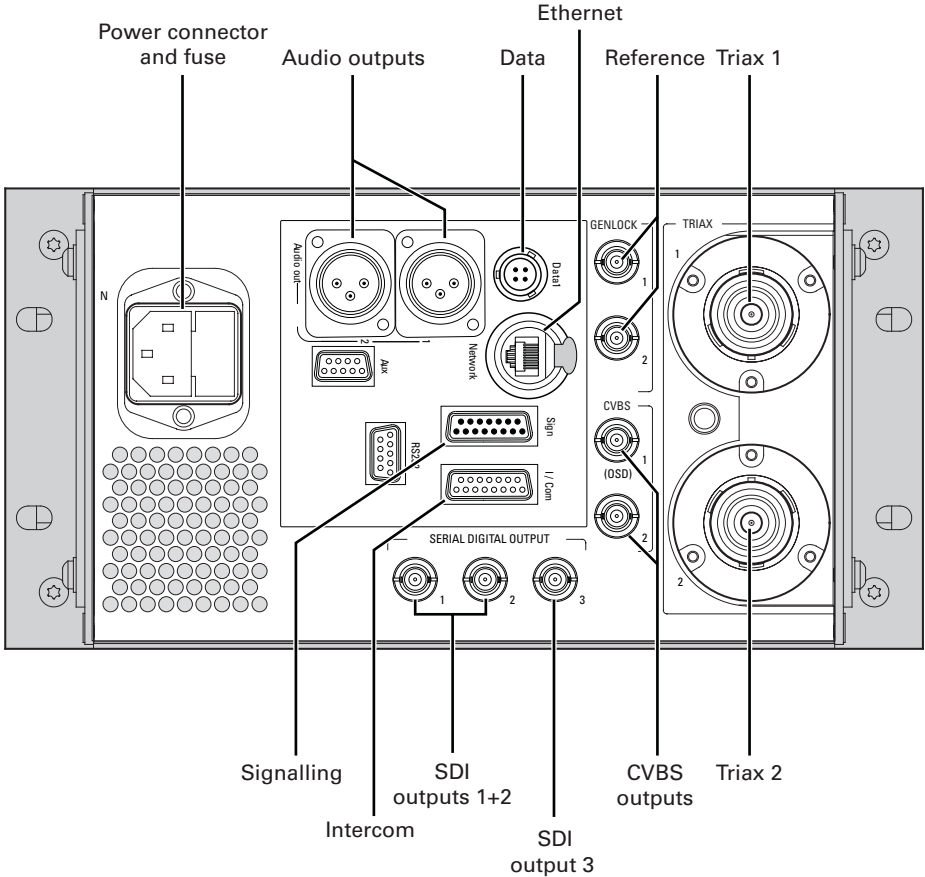

6.3.1 Triax connectors

Figure 6-12. Triax connector 1 + 2

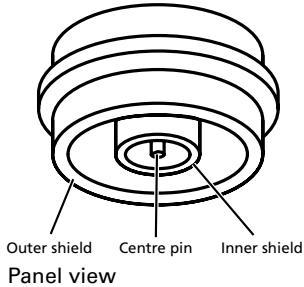

- 1. Centre pin: Power and signals
- 2. Inner shield: Return
- 3. Outer shield: Housing GND

This socket is used to connect the triax cable from the triax output of the AMU.

Receptacle types: Fischer, Tri-lock, ARD, Lemo 4, Lemo BBC, Lemo 3.

6.3.2 Power connector

Figure 6-13. Power connector and fuse

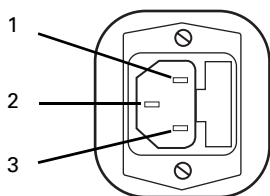

IEC style 3-pin male; panel view

1. Neutral
2. Ground (connected to chassis ground)
3. Phase

Connect a 100-125 Vac 60Hz or a 200-240 Vac 50Hz power supply to this connector (internal automatic switching).

Fuse type: T6.3 AH250V (remove power supply plug to access the fuse and the spare fuse.)

6.3.3 Intercom connector

Figure 6-14. Intercom connector

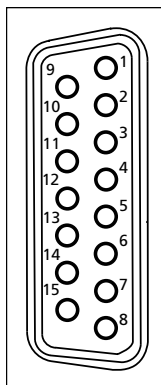

SubD 15-pin female; panel view

1. Prod. out (4-wire out, 2-wire in/out)
2. Prod. in (4-wire only)
3. Prod. in shield (4-wire only)
4. ENG in (4-wire only)
5. ENG out (4-wire out, 2-wire in/out)
6. PROG in (4-wire only)
7. PROG in shield (4-wire only)
8. Housing
9. PROD out return (4-wire out, 2-wire in/out)
10. PROD in return (4-wire only)
11. ENG in shield (4-wire only)
12. ENG in return (4-wire only)
13. ENG out return (4-wire out, 2-wire in/out)
14. PROG in return (4-wire only)
15. Housing

Shield of cable to the pin marked housing.

6.3.4 Signalling connector

Figure 6-15. Signalling connector

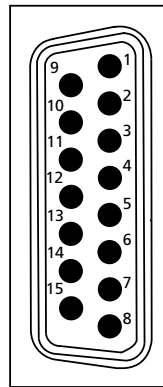

SubD 15-pin male; panel view

1. Prev. out ext. (relay contact <math>< 10 \Omega</math>)
2. Call out ext. (relay contact <math>< 10 \Omega</math>)
3. Iso in ext. (dry contact)
4. On-Air in ext (dry contact)
5. Call in ext. (dry contact)
6. Audio 1 level (analogue input voltage 0V to +5V)
7. +5 Vdc; OCP
8. Housing
9. Prev. out ext. return
10. Call out ext. return
11. Iso in ext. return
12. On-Air in ext. return
13. Call in ext. return
14. Audio 2 level (see pin 6)
15. GND

Shield of cable to the pin marked housing.

6.3.5 Audio out connectors

Figure 6-16. Audio out connectors 1 and 2

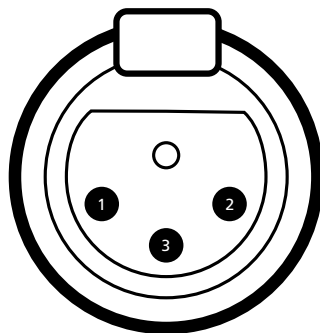

XLR 3-pin male; panel view

1. Shield
2. Audio +
3. Audio -

Nominal level 0dBu (+6dBu selectable)

Shield of cable directly to the connector housing.

If the same signal is applied at pin2 of Audio input 1 and 2 (WCA), then Signal at pin 2 of audio output 1 is in phase with signal at pin 2 of audio output 2.

6.3.6 Data connector

Figure 6-17. Data connector

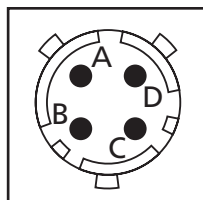

4-pin male; panel view

- A. Data
- B. Data not
- C. Not connected
- D. Shield

Shield of cable to the pin marked housing.

Connect a unit of the Series 9000 remote control family (OCP, MCP) to this connector via a standard 4-pole Souriau cable.

6.3.7 Ethernet connector

Figure 6-18. Ethernet connector (C2IP)

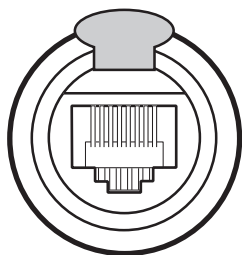

Neutrik RJ-45; panel view

8-pin Standard Ethernet RJ-45 connector

6.3.8 Reference input connectors

Figure 6-19. BNC reference input connectors

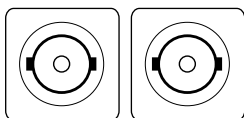

BNC connectors

This BNC connector accepts either a 1.0 Vpp CVBS SDTV composite or a 1.0 Vpp TLS-HDTV reference (should include H and V synchronization) signal to the camera for genlocking.

Note: The second connector should be terminated with 75 Ω if the signal is not looped through.

6.3.9 CVBS output connectors

Figure 6-20. CVBS output connectors (2)

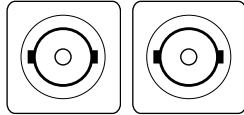

BNC connectors

These sockets provide an analog 1 Vpp CVBS output signal for monitoring purposes. The menu text is superimposed on this signal if the menu is switched on.

6.3.10 SDI output connectors 1 and 2

Figure 6-21. SDI output connectors 1 and 2

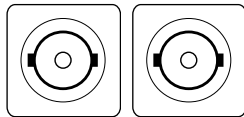

BNC connectors

These two BNC connectors provide a 0.8 Vpp SDI (SD or HD) output video signal according to SMPTE 259M-C or SMPTE 274M.

When used in SD mode, the menu text is superimposed on these signals if the menu is switched on.

6.3.11 SDI output connector 3

Figure 6-22. SDI output connector 3

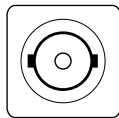

BNC connector

This BNC connector provides a 0.8 Vpp SDI (SD or HD) output video signal according to SMPTE 259M-C or SMPTE 274M.

When used in SD mode, the menu text is superimposed on these signals if the menu is switched on.

Chapter 7

Specifications

7.1 Specifications for Antenna Management Unit (AMU)

Item	Value
Dimensions (H x W x L)	250 x 200 x 480 mm (9.8 in 7.8 x 18.9 in)
Weight (approx.)	7.5 kg (16.5 lbs)
Operating temperature	-20 to +45 °C (0 to +113 °F)
Storage temperature	-20 to +60 °C (0 to +140 °F)
Environment	IP54 compliant
Data output	9-pin, D-connector female
UHF inputs	3 x BNC connectors with active loop-through
Triax output	Triax connector, towards WCU

7.2 Specifications for RF receiver units

Item	Value
Dimensions (H x W x L)	64 x 34 x 98 mm (2.5 x 1.3 x 3.9 in)
Weight (approx.)	0.3 kg (0.66 lbs) per unit
Operating temperature	-20 to +45 °C (0 to +113 °F)
Storage temperature	-20 to +60 °C (0 to +140 °F)
Environment	IP54 compliant
Frequency range	2.0 - 2.2 GHz, 2.2 - 2.4 GHz or 2.5 - 2.7 GHz (depending on module)
RF antenna	SMA connector
VHF output	BNC connector

7.3 Specifications for RF data emitter unit

Item	Value
Dimensions (H x W x L)	64 x 34 x 98 mm (2.5 x 1.3 x 3.9 in)
Weight (approx.)	0.3 kg (0.66 lbs) per unit
Operating temperature	-20 to +45 °C (0 to +113 °F)
Storage temperature	-20 to +60 °C (0 to +140 °F)
Environment	IP54 compliant
Modulation	FSK modulation
Frequency range	454.000 - 462.000 MHz
Number of channels	161 (in steps of 50 kHz)
Bandwidth	32.5 kHz (< 250 nW max.)
Baud rate	28,800 baud
Emitted power	24 dBm ± 2 dBm (conducted in 456 MHz range)
Applicable standards	Radio: ETS 300 220 Radio: FCC Part 74
RF antenna	BNC connector
Data input	9-pin, D-connector female

7.4 Specifications for Wireless Control Unit (WCU)

Item	Value
Weight (approx.)	7.0 kg (15.4 lbs)
Operating temperature	0 to +45 °C (32 to +113 °F)
Storage temperature	-20 to +60 °C (0 to +140 °F)
Power	100-125 VAC 60 Hz (3A) or 200-240 VAC 50 Hz (1.5A) max. 150 W depending on system configuration
Triax cable length (max.)	400 m (1,300 ft) for 8 mm (0.32 in) cable; 600 m (1,970 ft) for 11 mm (0.43 in) cable; 800 m (2,600 ft) for 14 mm (0.55 in) cable.
Video (3x)	SDI SMPTE 259M; HD or SD selectable, BNC-connector
CVBS	CVBS output monitoring quality; BNC-connector
Genlock in	SD (Black Burst) or HD-TLS; BNC-connector
Power in	IEC type, 3-pin male
Intercom	Full speech quality
Intercom input level	0 or +6 dBu selectable
Intercom output level	+6 dBu nominal (adjustable +/- 12 dB in 100 steps)
Audio level	Output level 0 or +6 dBu selectable
Applicable standards	EMC: EN 301489-3 Safety: EN 60950

7.5 Specifications for Wireless Camera Adapter (WCA)

Item	Value
Dimensions (H x W x L)	180 x 120 x 191 mm (7.1 x 4.7 x 7.5 in)
Weight	2.2 kg (4.9 lbs)
Operating temperature	-20 to +45 °C (0 to +113 °F)
Storage temperature	-20 to +60 °C (0 to +140 °F)
Power (system)	58 W (typ.) including LDK 8000 Elite camera head and 2-inch viewfinder
Power (WCA only)	< 28 W
Battery plate	Anton Bauer or IDX type
DC Input	12 V (11 to 17 V); 3.5A (excluding DC out); XLR-4
DC Output	11 to 17 VDC (battery voltage) 1.5 A; 6-pin Hirose
Video	SDI monitoring quality output
VF signal	B&W video 1.0 Vpp, 75 Ω output
Antennas	RX antenna; BNC connector, RF signal input TX antenna; SMA connector, RF signal output
RF module	COFDM (based on modified 802.16 layer)
Frequency ranges	2.0 - 2.2 GHz, 2.2 - 2.4 GHz or 2.5 - 2.7 GHz depending on module
Number of channels	181 (in steps of 1 MHz)
Emitted power	18 dBm ± 1.5 dBm (conducted) measured at T _{ambient} = 20° C
Bandwidth	18 MHz per channel (at -3 dB)
Bitrate	±31 to ±66 Mbit/s (depending on selected profile)
Intercom	Speech quality; latency to camera 250 ms Microphone level -44 to -24 dBu switchable Input impedance > 10 kΩ Telephone level +12 dBu nominal Telephone output impedance < 50 Ω
Audio	1 channel full bandwidth (22 kHz, S/N 63 dB typical) or 2 channels reduced bandwidth (15 kHz, S/N 60 dB typical) Input impedance > 10KΩ Sensitivity range: -64 to -22 dBu or line (0 dBu)
Tally out	On: +5 VDC; Off: 0 VDC (CMOS levels)
Applicable standards	Radio: ETS 300 440
External video	1.0 Vpp (C)VBS input

7.6 Specifications for LDK 5455 Video Booster (optional)

Item	Value
Dimensions (H x W x L)	210 x 130 x 45 mm (8.3 x 5.1 x 1.8 in) excluding battery socket
Weight	1.4 kg (3.1 lbs)
Operating temperature	-20 to +45 °C (0 to +113 °F)
Storage temperature	-20 to +60 °C (0 to +140 °F)
Environment	IPX2 (drip proof)
Application	COFDM Video Booster 500 mW
Frequency range	2.0 - 2.2, 2.2 - 2.4 GHz and 2.5 - 2.7 GHz
Power consumption	25 W (typ.)
Battery types	LDK 5455/50 (Anton Bauer version); LDK 5455/60 (IDX version)
Battery input voltage	10.5 VDC to 17 VDC
Battery input current	3 A max.
RF input level	+18 dBm input for 0.5 W (+27 dBm) typical output
RF input	Return loss < -15 dB
RF input connector	SMA-type (female) 50 Ω
RF output level	500mW typical (+27 dBm) for + 18 dBm input
RF output accuracy	+1 / -2 dBm
RF output	Return loss < -10 dB
RF output connector	N-type (female) 50 Ω

Exchanging the RF module

In some situations you may choose to use a different frequency band. To use a different band, you need to exchange the right side cover (= camera RF module) of the wireless camera adapter.



Caution

Exchange of the camera RF Module must only be performed by qualified personnel.

Choose the frequency module for your frequency band:

- LDK 5456/20: Camera RF module 2.0 - 2.2 GHz
- LDK 5456/22: Camera RF module 2.2 - 2.4 GHz
- LDK 5456/25: Camera RF module 2.5 - 2.7 GHz

To install the module you need to exchange the entire right side cover of the wireless camera adapter as follows:



Caution

Do not immediately remove the panel from the adapter after unscrewing; it is connected by two cables to the adapter.

1. Unscrew the five screws securing the right side cover of the adapter and carefully open the unit.
2. Disconnect the coaxial cable from the adapter side and the flat cable from the RF module side.
3. Connect the cables between the new RF module and the adapter.
4. Fold the cable into the space between the printed circuit board and the upper guiding rail to make sure that it will not get stuck.
5. Mount the module on the adapter and secure it with the five screws.
6. Change the frequency range in the WCU menu.

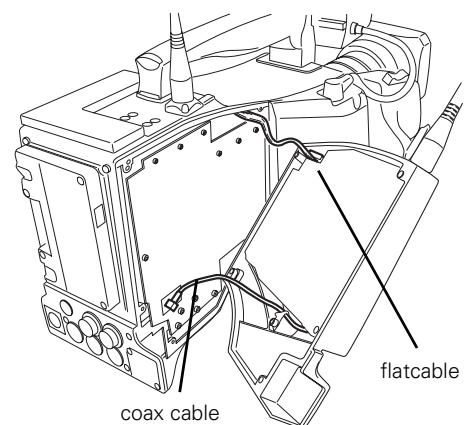
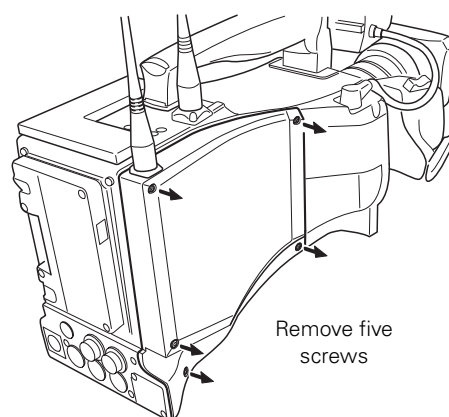

Installing the Video booster

Introduction

The Video Booster for wireless cameras is a highly linear RF amplifier designed to be used as an accessory to the HD Wireless Camera Adapter. The Video Booster operates over a range from 2,000 to 2,700 MHz and delivers up to 500mW of conducted power.

The Video booster is mounted between the back panel of the Wireless Camera Adapter and the battery. It can be delivered for two types of battery systems: IDX (LDK5455/60) or Anton Bauer (LDK5455/50) to be specified when ordered.

Package contents

- Video RF booster unit (equipped with either a IDX or Anton Bauer battery interface).
- RF coaxial cable (with SMA right-angled connector to SMA right-angled connector).
- Flexible antennas (with N-type male connector). Use **only** the antenna that matches your RF module:
 - LDK 5457/20 (2.0 - 2.2 GHz)
 - LDK 5456/22 (2.2 - 2.4 GHz)
 - LDK 5456/25 (2.5 - 2.7 GHz)

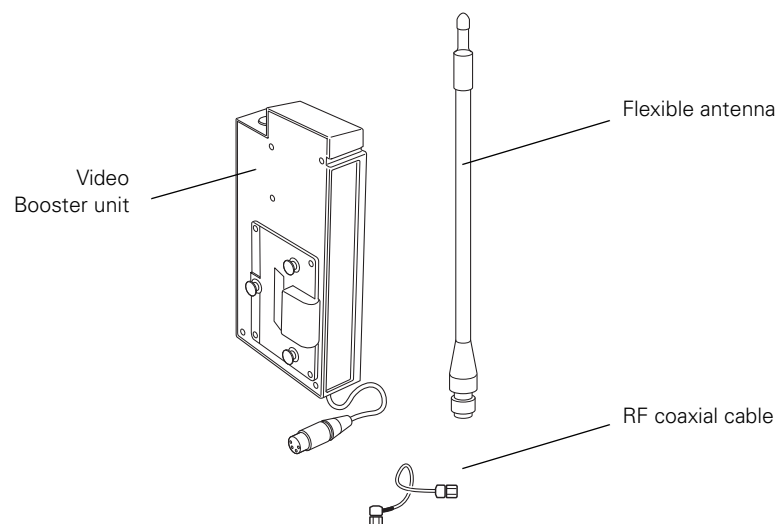

Assembly

1. Switch off the camera.
2. Remove the battery from the camera adapter.
3. Plug the booster onto the camera adapter battery plate.

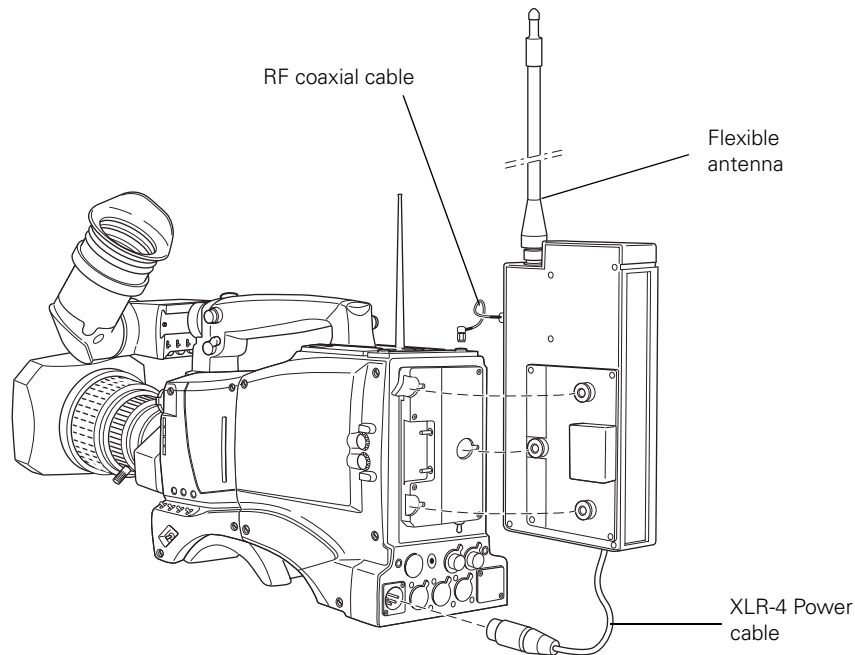

4. Plug the XLR-4 power cable from the booster in the XLR-4 power receptacle on the camera adapter.
5. Connect the RF coaxial cable between the output of the camera adapter and the input of the booster.
6. Screw the correct flexible antenna on the booster according to your RF module:
 - use the LDK5457/20 antenna with LDK5451/20 RF module (2.0 to 2.2 GHz)
 - use the LDK5457/22 antenna with LDK5451/22 RF module (2.2 to 2.4 GHz)
 - use the LDK5457/25 antenna with LDK5451/25 RF module (2.5 to 2.7 GHz)
7. Install the battery onto the back panel of the booster.
8. Switch on the camera.

Recommendation

The HD Wireless Camera Adapter has an internal digital attenuator. It allows you to reduce RF output power to a value that is sufficient for your particular operating conditions. Maximum power is not always needed and it is good practice to reduce output power to the minimum required to reduce exposure and possible interaction between adjacent cameras.

To reduce the RF output power level set the `EXT. BOOST ADJUST` in the `INSTALL/WIRELESS` menu of the camera to a value greater than 0. Each time this parameter is increased by +2, the RF output power level is decreased by 1 dB with respect to its nominal value.

