

Bluetooth Smart DC Power Meter with Low Voltage and Over-current Disconnect

– BT-DCPM –

BRIEF

The BT-DCPM device is a Bluetooth Smart DC power meter allowing remote monitoring of important electrical parameters in DC circuits. BT-DCPM is also able to drive a mechanical or solid-state relay allowing it to function as a low voltage, over-current disconnect, remote on/off or timer. The following can be monitored: two voltage inputs (0-60V), current (0-60A using the internal shunt resistor or up to 300-600A using an external shunt resistor), power (W), energy (Wh), battery charge flow (Ah) and temperature. The power meter can function in either unidirectional or bidirectional current mode. It can sense current flow in both directions (positive and negative current). A mobile device running either Android or iOS and the provided applications (available for free on Google Play Store and Apple App Store) are required for monitoring and configuring of the device.



Figure 1. BT-DCPM

FEATURES

- Ideal for remotely monitoring DC current flow unidirectionally (positive only) or bidirectionally (positive and negative) and up to two voltage inputs for monitoring battery banks
- Low voltage disconnect
- Over-current disconnect (circuit-breaker)
- Measures voltage, current, power, battery charge meter (Ah), energy meter (Wh) and temperature
- Operates at up to 60V and 60A of continuous current (75A peak current) using the internal shunt resistor
- High current aluminum lug terminals supporting up to 65A
- If used with an external shunt resistor it senses up to 150mV of voltage drop allowing the use of high power 300A-600A rated shunt resistors
- Very low power consumption (see Performance Parameters)
- Bluetooth Smart (LE) radio with internal antenna
- 8-pole terminal block for connecting to the system that will be monitored
- ABS plastic enclosure with mounting flanges, completely enclosed in potting compound
- Measures only 3.0" x 1.55" x 0.75" (76mm x 39mm x 19mm) including the mounting flanges.
- Weatherproof
- Can be monitored and configured using the provided mobile device application
- The measurement range can be configured allowing it to achieve top performance with a variety of shunt resistor

TYPICAL APPLICATIONS

- Boats, RVs, small cabins
- Solar systems, wind systems, renewable energy
- Battery backup systems / battery operated equipment
- Power inverters, electric vehicles
- Monitoring of fleet vehicle battery

PINOUT / PIN DESCRIPTION

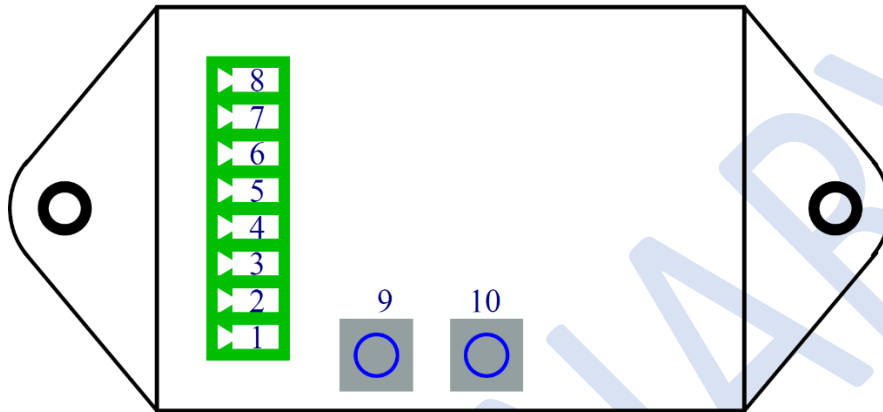

Figure 2. BT-DCPM Pinout

Pin	Name	Description
1	GROUND	System Ground
2	DATA	DO NOT CONNECT! (contact Thornwave Labs Inc. for more information)
3	PE	Power Enable output - Open drain, active low output. Used to control a mechanical or solid-state relay. Pin is pulled low (to ground) when active. The relay should be connected between the power supply for the relay and this pin. The voltage at this pin should not exceed 18V.
4	ES+	External Shunt connection (positive side – closest to the power source). When using the internal current shunt connect this pin to ES- (pin 5)
5	ES-	External Shunt connection (negative side – farthest from the power source). When using the internal current shunt connect this pin to ES+ (pin 4)
6	VS	Optional power supply. Optionally, connect this pin to a power supply of no more than 18V
7	V2	Second monitored voltage. Used to monitor a second battery.
8	V+	Main power. This is the main voltage that will be monitored. The device also draws its power from this pin. If power is applied to Pin 6 (VS), the device will draw its power from that instead of this pin.
9	IS-	Internal Shunt connection (negative side – farthest from the power source). Do not connect if using an external shunt.
10	IS+	Internal Shunt connection (positive side – closest to the power source). Do not connect if using an external shunt.

SPECIFICATIONS

Absolute Maximum Ratings ^{1,2}	
Maximum Voltage (V+, V2)	+65V
Maximum Current (using internal shunt)	60A cont. 75A peak
Maximum Current (using external shunt)	depends on external shunt (300A – 600A max)
Maximum Input Sense Voltage (using external shunt – between ES+ and ES-) - differential	65V
Minimum Input Sense Voltage (ES+, ES-, IS+, IS-)	-2V
Maximum Input Sense Voltage (ES+, ES-, IS+, IS-)	+65V
Operating Temperature	-30°C to +70°C

Recommended Operating Conditions ³	Min	Max
Input Voltage (V+ to GND)	+9V	+60V
Current (using internal shunt IS+ / IS-)	0	60 A
Input Sense Voltage (using external shunt – between ES+ and ES-)	0	180 mV/±80mV
Operating Temperature	-30°C	+70°C

1. Stresses greater than those listed under “Absolute Maximum Ratings” may cause permanent damage to the device.
2. Continuous operation at levels higher than those listed under “Recommended Operating Conditions” may cause permanent damage to the device
3. All voltages are referenced to ground unless otherwise specified.

Performance Parameter	Value
Measured voltage (V+, V2)	0 – 60V / ~8mV resolution
Measured voltage accuracy	better than 0.5%
Measured current (using internal shunt IS+, IS-)	0 – 60A / ~8mA resolution
Measured current accuracy (using internal shunt)	better than 1% - when calibrated
Internal current shunt resistance	0.5 mOhm / ±1%
Voltage sense input (using external shunt ES+ to ES-)	0 – 180mV / ~20µV resolution
Current monitoring accuracy (using external shunt)	depends on external shunt resistor precision, typically better than 1%
Minimum external current shunt resistance	0.1 mOhm
Power (using internal shunt)	max. 3600W
Power meter	more than 1000 MWh
Charge meter	more than 1000 MAh
Temperature	1°C / 1°F resolution
Current draw (current consumed by the device)	
at 12V	7.0 mA
at 24V	7.3 mA
at 36V	7.7 mA
at 48V	8.0 mA
at 60V	8.5 mA

COMPLIANCE STATEMENTS

FCC

ATTENTION: Changes or modifications not expressly approved by Thornwave Labs Inc could void the user's authority to operate the equipment.

ATTENTION: This device complies with Part 15 of the FCC rules. Operation is subject to the following two conditions: (1) this device may not cause harmful interference and (2) this device must accept any interference received, including interference that may cause undesired operation.

ATTENTION: Cet appareil est conforme à la Partie 15 des règlements de la FCC. L'opération doit se conformer aux deux conditions suivantes: (1) cet appareil ne peut causer d'interférences nuisibles et (2) cet appareil doit accepter toute interférence reçue, y compris les interférences qui peuvent provoquer un fonctionnement indésirable.

IC RSS-102 RF Exemption

This system has been evaluated for RF Exposure per RSS-102 and is in compliance with the limits specified by Health Canada Safety Code 6.

L'exposition aux radiofréquences de ce système a été évaluée selon la norme RSS-102 et est jugée conforme aux limites établies par le Code de sécurité 6 de Santé Canada.

IC RSS-Gen 8.4

This device complies with Industry Canada license-exempt RSS standard(s). Operation is subject to the following two conditions: (1) this device may not cause interference, and (2) this device must accept any interference, including interference that may cause undesired operation of the device.

Le présent appareil est conforme aux CNR d'Industrie Canada applicables aux appareils radio exempts de licence. L'exploitation est autorisée aux deux conditions suivantes: (1) l'appareil ne doit pas produire de brouillage, et (2) l'utilisateur de l'appareil doit accepter tout brouillage radioélectrique subi, même si le brouillage est susceptible d'en compromettre le fonctionnement.

SAFETY INSTRUCTIONS

Warning !

Read all the instructions and cautions before using the power meter.

Warning !

There are no serviceable parts or fuses inside the power meter! Do not disassemble or attempt to repair! The unit operates with voltages up to 60V which can be deadly or cause serious and permanent injury.

Warning !

Do not submerge under water or other liquids. The device is weatherproof but not waterproof.

Warning !

The power meter is to be connected to DC circuits only, not exceeding 60V or 60A (using the internal shunt). Failure to do so will result in equipment damage. Higher currents are supported when using an external shunt resistor. Confirm that all connections are tight to avoid excessive heating and sparks.

Warning !

Batteries are dangerous! Do not short-circuit a battery or the power meter. Batteries can produce flammable and explosive gases and can generate very high currents that can lead to serious consequences including explosion, fire, damage to equipment, personal injury and even death. It is the user's responsibility to operate the equipment in a safe manner. Do not charge batteries in an enclosed environment unless allowed by the manufacturer of the battery.

FUNCTIONAL OVERVIEW

Device power. BT-DCPM is drawing its supply power from the V+ pin and using an internal voltage regulator it creates an internal supply voltage of 9V. This internal supply voltage is available at the VS pin and should not be used to supply any external load. Attempting to power external loads from the VS pin will damage the device. If a power supply of maximum of 18V is available it is recommended to connect it to the VS pin. This will turn the internal regulator off and improve efficiency. When the device is used to monitor 12V batteries, V+ and VS pins can be wired together to the positive side of the 12V battery. For use in higher system voltages, the VS pin should be left unconnected.

Internal current shunt. When using the internal current shunt, the ES+ and ES- pins should be wired together using a wire bent in a U shape. The current to be monitored should be routed through the IS+ and IS- terminals. An internal shunt resistor of 0.5mOhm is connected in between these two terminals. The aluminum, hex screw terminal blocks (IS+ and IS-) can accept wires up to 6AWG in size. In order to minimize the voltage drop on wires and connections, use the thickest wires that can support the required current. The common mode voltage of IS+ and IS- can be in between -2V and +65V relative to ground, allowing the current shunt to be placed either on the positive side of the circuit or on the ground wire (less common). Current flowing from IS+ to IS- will be measured as a positive value and current from IS- to IS+ will be a negative measured value.

External current shunt. To monitor a large current or a very small current more accurately, an external current shunt can be used. This method allows monitoring currents up to 300-600A with reasonable resolution or even higher if resolution can be sacrificed. Using a higher current shunt resistor, currents in the milli-amp range can be measured accurately. The external current shunt resistor should be connected to the ES+ and ES- pins. To avoid noise the wires should be as short as possible. Twisting the sense wires can reduce noise even further. Pins IS+ and IS- should be left unconnected. The common mode voltage of ES+ and ES- can be in between -2V and +65V relative to ground, allowing the current shunt to be placed either on the positive side of the circuit or on the ground wire (less common). Current flowing from IS+ to IS- will be measured as a positive value and current from IS- to IS+ will be a negative measured value.

Operation. Once the device receives power it will start advertising its presence to other Bluetooth devices. Using a cell-phone or tablet running the DCPM application (found on the App Store / Play Store) the user can scan for BT-DCPM devices and connect to one of them (if multiple devices are present). Multiple BT-DCPM devices can be distinguished after changing their name using the mobile app. This will be displayed by the application upon scanning for Bluetooth devices. Once the mobile device is connected to a power monitor the application will display all the electrical parameters and update them in real-time. Using the application menu, the user can configure the device or reset the charge and power meters back to zero. The DC power meter will consume very little current, allowing for continuous operation from batteries. The power monitor can operate in unidirectional or bidirectional current mode. While operating in unidirectional current mode, the current can only be sensed in one direction (from IS+/ES+ to IS-/ES-). In this case, the device is capable of higher dynamic range than in the

bidirectional current mode. In the bidirectional current mode, the power monitor can sense current in both directions. The current from IS+/ES+ to IS-/ES- will show as a positive value while the reverse current (for example recharging the battery) will be shown as a negative value.

Power relay control. BT-DCPM can control a power relay (either mechanical or solid-state) using the PE output (terminal 6). When active, the PE pin is internally connected to ground. The relay should be connected between the power supply for the relay (max 18V) and the PE pin. The low voltage disconnect function can be configured and enabled using the mobile application.

Low voltage disconnect. When this mode is enabled and the battery voltage drops below a specified value, the device disconnects the load, protecting the batteries from over-discharge. In order to disconnect the load, the voltage has to be below the set threshold for an amount of time that can be configured. This feature helps in situations where cranking an engine or a short high current load causes the battery voltage to momentarily drop. The device will re-engage the power relay 10 seconds after the condition that caused it to disconnect is removed.

Over-current disconnect. BT-DCPM can operate as a circuit breaker. When this mode is enabled and the measured current increases above a user specified trip value, the device disconnects the load, protecting the batteries and load from over-current. The device will re-engage the power relay 10 seconds after the condition that caused it to disconnect is removed.

WARNING! Although BT-DCPM can disconnect power on over-current it should not be used to replace circuit-breakers. A properly rated circuit-breaker or fuse should be used to protect the load and the wiring!

Radio performance. The device contains an internal Bluetooth Smart (LE) radio operating in the 2.4GHz band and an internal antenna. For best performance, the device should be installed in such a way to offer a path for radio waves to reach it. Metal walls or enclosures can attenuate or completely shield the device. Installation on non-metallic surfaces is preferred.

Configuration. The following parameters can be configured from the included mobile applications.

Connect Filter (ms): The time delay in milli-seconds used to re-engage the power relay after the condition that caused the disconnect is removed (either low voltage or over-current).

LVD Disconnect Threshold: The voltage in volts below which the power relay will disconnect.

LVD Connect Threshold: The voltage in volts above which the power relay can re-engage (after the filter time has passed). This must be higher than LVD Disconnect Threshold

OCD Trip Threshold: The current in amperes at which the power is disconnected.

OCD Filter (ms): The duration of time the current has to be above the trip value in order to disconnect. In order to function as a circuit breaker this should be set to a very low value between 0ms .. 20ms.

Sense Resistor: The resistance value in milli-ohms of the shunt resistor used. By default it is set to 0.5mOhm which is the internal shunt resistance.

Sense Voltage Range: The shunt resistor voltage drop range. This should be adjusted to be higher than the maximum expected voltage drop.

Unidirectional (positive current only)	Bidirectional (positive and negative current)
+180mV	-
+150mV	-
+120mV	-
+90mV	±80mV
+60mV	±60mV
+30mV	±30mV
-	±15mV
-	±7.5mV

Configuration example. Let's suppose a current of up to 400A needs to be measured bidirectionally. Deltec manufactures a DC ammeter shunt of 500A / 50mV which can be purchased from Amazon.

Ohm's law states:

$$V = I * R$$

This means that the voltage drop on a resistor is equal to the current passing through that resistor multiplied by the resistance value. Rearranging that equation, we get: $R = \frac{V}{I}$. Using this we can calculate the resistance of the Deltec shunt being:

$$\frac{0.05V(50mV)}{500A} = 0.0001Ohm = 0.1mOhm$$

In order to properly configure BT-DCPM we set the Sense Resistor to 0.1mOhm and Sense Voltage Range to ±60mV since this is the next higher range available that can be used for measuring up to 50mV. Using the ±60mV range allows a current up to ±600A to be measured using the Deltec shunt but the 500A shunt rating should not be exceeded.

Time keeping. BT-DCPM keeps track of time internally. Every time a mobile device connects, the DCPM date and time will be updated using the system time provided by the mobile device.

WIRING DIAGRAM (using the internal current shunt)

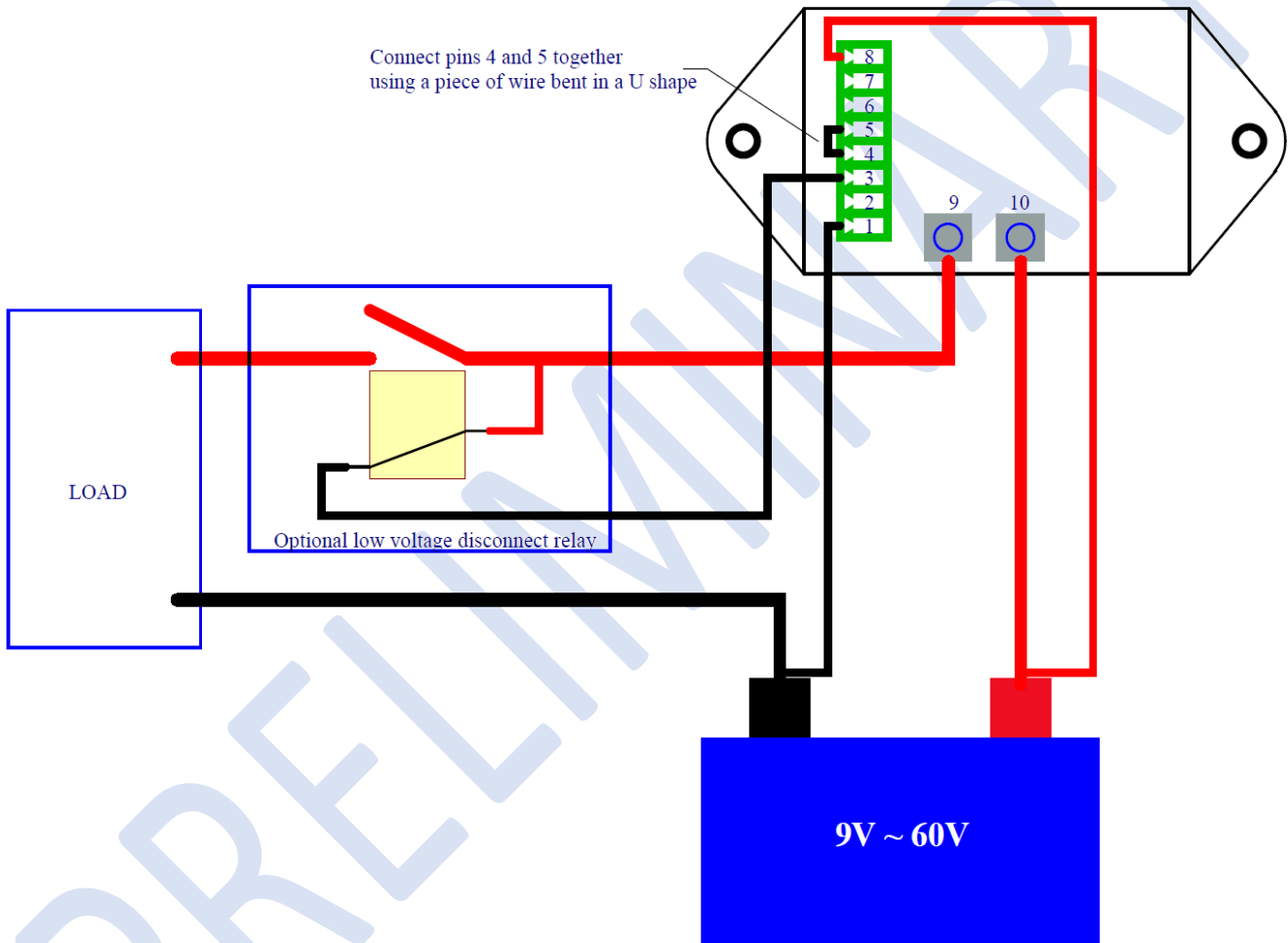

Figure 3. Wiring diagram (internal shunt)

WIRING DIAGRAM (using an external current shunt)

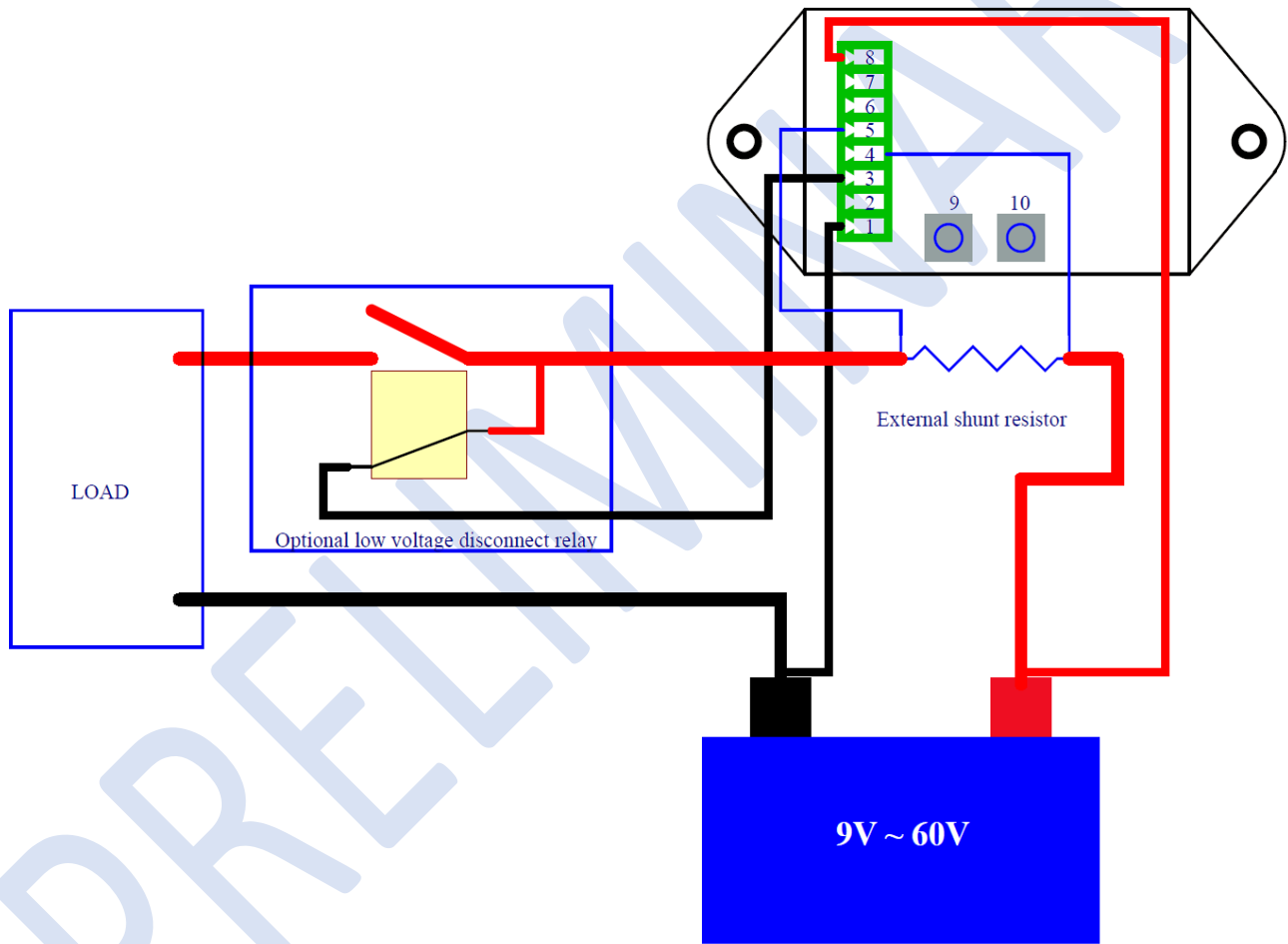

Figure 4. Wiring diagram (external shunt)

DIMENSIONS

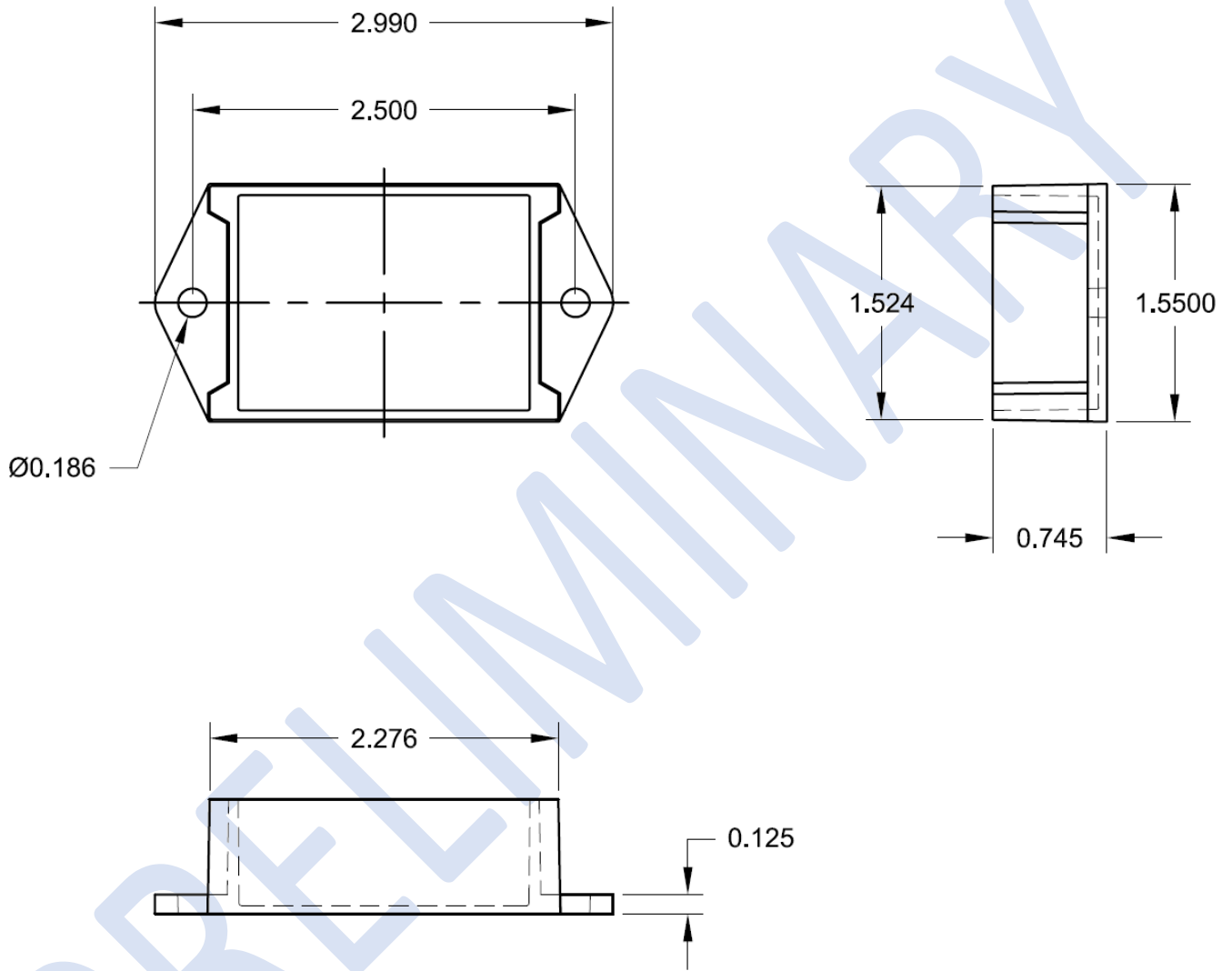

Figure 5. Dimensions (inch)

ORDERING

Part Number	Description
BT-DCPM	Bluetooth Smart DC Power Meter with low voltage and over-current disconnect

PRELIMINARY

Current Revision: **1.03**

Revision	Date	Revision Description
1.00	8/1/2017	Initial preliminary version.
1.01	8/7/2017	Added FCC/IC required warnings
1.02	8/9/2017	Revised FCC/IC required warnings.
1.03	7/17/2017	Added FCC required statement.

PRELIMINARY