

SAILOR 6101 and SAILOR 6103 Alarm Panel



SAILOR 6101 and SAILOR 6103 Alarm Panel

Installation and user manual

Document number: 98-130981-DraftA7

Release date: July 5, 2010

Disclaimer

Any responsibility or liability for loss or damage in connection with the use of this product and the accompanying documentation is disclaimed by Thrane & Thrane. The information in this manual is provided for information purposes only, is subject to change without notice and may contain errors or inaccuracies. Manuals issued by Thrane & Thrane are periodically revised and updated. Anyone relying on this information should acquire the most current version e.g. from <http://www.thrane.com> or from the distributor. Thrane & Thrane is not responsible for the content or accuracy of any translations or reproductions, in whole or in part, of this manual from any other source.

Copyright

© 2010 Thrane & Thrane A/S. All rights reserved.

Trademark Acknowledgements

- **Thrane & Thrane** is a registered trademark of Thrane & Thrane A/S in the European Union and the United States.
- **Inmarsat** is a registered trademark of the International Maritime Satellite Organisation (IMSO) and is licensed by IMSO to Inmarsat Limited and Inmarsat Ventures plc.
- **SAILOR** is a registered trademark of Thrane & Thrane A/S in the European Union, the United States and other countries.
- Other product and company names mentioned in this manual may be trademarks or trade names of their respective owners.

Safety summary

The following general safety precautions must be observed during all phases of operation, service and repair of this equipment. Failure to comply with these precautions or with specific warnings elsewhere in this manual violates safety standards of design, manufacture and intended use of the equipment. Thrane & Thrane assumes no liability for the customer's failure to comply with these requirements.

DO NOT OPERATE IN AN EXPLOSIVE ATMOSPHERE

Do not operate the equipment in the presence of flammable gases or fumes. Operation of any electrical equipment in such an environment constitutes a definite safety hazard.

KEEP AWAY FROM LIVE CIRCUITS

Operating personnel must not remove equipment covers. Component replacement and internal adjustment must be made by qualified maintenance personnel. Do not service the unit with the power cable connected. Always disconnect and discharge circuits before touching them.

DO NOT SUBSTITUTE PARTS OR MODIFY EQUIPMENT

Because of the danger of introducing additional hazards, do not substitute parts or perform any unauthorized modification to the equipment.

COMPASS SAFE DISTANCE

Minimum compass safe distance: 1 m.

Failure to comply with the rules above will void the warranty!

About the manual

Intended readers

This manual is an installation and user manual for the two types of Alarm Panel, SAILOR 6101A and SAILOR 6103A. The manual is intended primarily for installers of the system and service personnel. Personnel installing or servicing the system must be properly trained and authorized by Thrane & Thrane. It is important that you observe all safety requirements listed in the beginning of this manual, and install the system according to the guidelines in this manual.

Manual overview

This manual has the following chapters:

- **Introduction** - a short description of the two types of Alarm Panel.
- **Using the Alarm Panel** - a short guide on how to use the Alarm Panel to send distress alerts, receive distress or urgency messages, set up light and sound and test the Alarm Panel.
- **Installing the Alarm Panel** - a description of how to unpack, store and install the Alarm Panel.
- **Connecting cables** - descriptions and pin-out for the connectors, guidelines for connecting the Alarm Panel and descriptions of the buttons.
- **Service and repair** - a short description of how to handle defective units.
- **Specifications** - technical specifications for the Alarm Panel.

Table of Contents

Chapter 1	Introduction	
	The Alarm Panel	1
Chapter 2	Using the Alarm Panel	
	Starting up the Alarm Panel	6
	Sending a Distress alert	7
	Receiving Distress or Urgency messages	8
	Displaying faults	9
	General functions	10
Chapter 1	Installing the Alarm Panel	
	Initial inspection	14
	Storage	14
	To install the Alarm Panel	15
Chapter 2	Connecting cables	
	Connectors	22
	Cable requirements	26
	Connecting the Alarm Panel	27
	Connecting multiple Alarm Panels	28
Chapter 3	Service and repair	
	Introduction	29
	Repacking for shipment	30

App. A	Specifications	
	General specifications	31
Glossary	33
Index	35

Introduction

The Alarm Panel

The Alarm Panel is used for sending distress alerts and showing visible and audible indication of incoming distress messages. Normally the Alarm Panel is installed at the conning position on the bridge.

The distress buttons are protected by spring loaded covers to avoid unintended activation of a distress alert. The distress buttons must be pressed for 3 to 6 seconds before the distress alert is initiated.

The Alarm Panel is supplied from 10.8 - 32 V DC. The input is protected against reverse polarity.

Note

In Inmarsat C GMDSS systems it is mandatory to have two distress buttons. If you have a Mini-C GMDSS system, only one alarm panel is required, because the Message Terminal, which is part of the system, has a distress button.

Single or Multi Alarm Panel

There are two variants of the Alarm Panel: The SAILOR 6101A and the SAILOR 6103A.

- The SAILOR 6101A Alarm Panel has one distress button and can send distress alerts and receive information on incoming distress messages via the Inmarsat C satellite system only.
- The SAILOR 6103A Multi Alarm Panel has three distress buttons and can send distress alerts via Inmarsat C, and distress calls via VHF and MF/HF. It can also receive information on incoming distress messages.

SAILOR 6101A Alarm Panel

The SAILOR 6101A Alarm Panel is dedicated to Inmarsat C. It has one distress button for sending distress alerts over the Inmarsat C satellite network.

The display shows distress alert transmission in progress and distress alerts received on the Inmarsat C network.



Through the Ethernet connector you can interface to two Inmarsat C systems.

Note

If a distress alert is initiated on a system with duplicated units, only one of the units will send the alarm. The display shows a marker next to the name of the selected unit.

SAILOR 6103A Multi Alarm Panel

The SIALOR 6103A Multi Alarm Panel connects to VHF equipment, MF/HF equipment and Inmarsat C equipment, and has a distress button for each type of system.

The display shows distress messages received. It also indicates equipment type (VHF, MF/HF or Inmarsat C) when the equipment is detected by the Multi Alarm Panel.



Through the Ethernet connector you can interface to two Inmarsat C systems, two VHF systems and two MF/HF systems.

Note

If a distress alert is initiated on a system with duplicated units, only one of the units will send the alarm. The display shows a marker next to the name of the selected unit.

Using the Alarm Panel

This chapter provides a description of how to use the Alarm Panel. It has the following sections:

- *Starting up the Alarm Panel*
- *Sending a Distress alert*
- *Receiving Distress or Urgency messages*
- *Displaying faults*
- *General functions*

Starting up the Alarm Panel

To start up the Alarm Panel, do as follows:

1. Switch on the Alarm Panel.
Use the remote on/off switch, if installed. otherwise, the Alarm Panel is automatically powered with the system.
2. The first column of the display shows which systems are connected to the Alarm Panel. A marker next to a system shows that it is the primary system for sending distress alerts or distress calls.

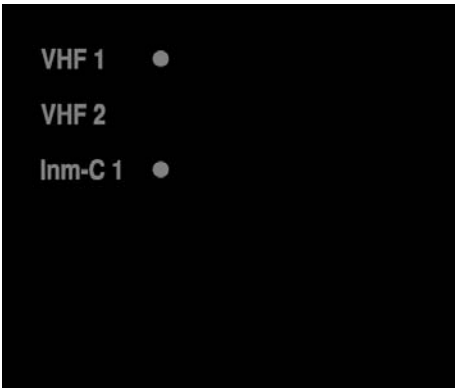

In the example above, two VHF radios and one Inmarsat C system are connected to the Alarm Panel. VHF 1 and Inm-C 1 can be used for sending a distress call/alert.

- On the SAILOR 6101A you can connect two Inmarsat C systems.
- On the SAILOR 6103A you can connect two VHF systems, two Inmarsat C systems and two MF/HF systems.

Sending a Distress alert

Important | Never send a Distress alert if you are not in distress!

To send a Distress alert, do as follows:

1. Open the cover for the Distress button you want to use (VHF, Inm C or MF/HF).
2. Press and hold the button until the light is steady and the buzzer stops (approximately 5 seconds).



Behavior	Meaning
Button light flashes, buzzer sounds. Marker in the display flashes with the button light.	The Distress button is pressed. Hold until light and sound changes (approximately 5 seconds).
Button light constant, buzzer is silent	The Distress alert is being sent (normally within 10 to 30 seconds)
Button light shortly off every 15 seconds	In Inmarsat C systems: The Distress alert is confirmed

For further details, see the user manual for the system you are using (VHF, Mini-C GMDSS or MF/HF).

Receiving Distress or Urgency messages

When a Distress or Urgency message is received, the display of the Alarm Panel shows a flashing Distress text and the buzzer sounds periodically. The Distress text is shown next to the system on which the message was received.



Check the connected system to see the contents of the message. In the example above check the Message Terminal in your Inmarsat C system to see the message.

Displaying faults

The display of the Alarm Panel can show faults in the connected VHF, Inmarsat C or MF/HF equipment.

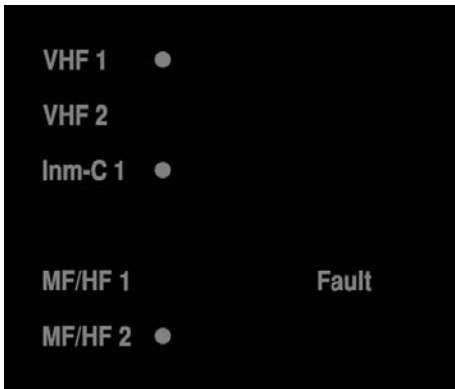



Check the connected equipment for the cause of the fault. In the example above, you should check MF/HF radio number 1.

Note

If the defective system is configured to be the primary system for sending distress, the other system of the same type (if any) is automatically selected in stead. In the example above, MF/HF 2 is automatically selected because MF/HF 1 is defective.

General functions

Buttons in front panel

Apart from the Distress button(s) described in *Sending a Distress alert* on page 7, the front panel has four other buttons: Test, Mute, **Dim**  and **Dim**  .

Testing the Alarm Panel

Note

This test only verifies the function of the Alarm Panel itself, not of any connected equipment or the total system. For information on how to test the system, refer to the manual for the individual system (Inmarsat C, VHF or MF/HF).

To test the light and sound indicators in the Alarm Panel, do as follows:

1. Press and hold the **Test** button.
Verify that all light indicators and alarm buttons are flashing.
2. While holding the **Test** button, press any other button, including the Distress button.
The buzzer sounds to indicate that the pressed button and the buzzer is working.

Muting the alarm sound

To mute the alarm sound while it is on, press the **Mute** button.

Note

Alarm sounds are muted on all connected units until they are activated by a new event.

Adjusting the light

To increase the light intensity, press and hold the **Dim** ↑ button.

To decrease the light intensity, press and hold the **Dim** ↓ button.

Note

The light always goes to full intensity if there is an event such as a Distress message, a fault or the Test button is pressed.

You can always use the Dim buttons to dim the light again if you want to.

Installing the Alarm Panel

This chapter provides a description of how to unpack, store and install the Alarm Panel. It contains the following sections:

- *Initial inspection*
- *Storage*
- *To install the Alarm Panel*

For information on cable connections, see *Connecting cables* on page 21.

Initial inspection



Warning! To avoid electrical shock, do not apply power to the Alarm Panel if there is any sign of shipping damage to any part of the front or rear panel or the outer cover. Read the safety summary at the front of this manual before installing or operating the Alarm Panel.

Inspect the shipping carton immediately upon receipt for evidence of mishandling during transport. If the shipping carton is severely damaged or water stained, request that the carrier's agent be present when opening the carton. Save the carton packing material for future use.

Check that the contents of the shipment are according to the enclosed packing list. If the contents are incomplete, if there is mechanical damage or defect, or if the Alarm Panel does not work properly, notify your dealer.

After unpacking the Alarm Panel, inspect it thoroughly for damage and loose components or fittings.

Storage

The Alarm Panel may be stored or shipped in temperatures between -40°C and $+80^{\circ}\text{C}$. Protect the Alarm Panel from extreme temperature variation which can cause condensation.

We recommend that you unpack the Alarm Panel immediately on delivery.

To install the Alarm Panel

General installation requirements

Normally the Alarm Panel is installed at the conning position on the bridge. You can mount the Alarm Panel as a flush-mounted unit integrated in a console, on a desktop or in an overhead position.

Make sure the Compass Safe Distance is maintained. See *General specifications* on page 31.

Mounting the Alarm Panel

Note

The mounting procedure is the same for the Alarm Panel and the Multi Alarm Panel so the descriptions in this chapter cover both types of Alarm Panel.

The next pages describe how to mount the Alarm Panel on a desktop, in an overhead position and flush mounted in a console.

Desktop mounting

You can mount the Alarm Panel on a desktop using the mounting bracket. For details on how to mount the Alarm Panel, see *Mounting the Alarm Panel with the mounting bracket* on page 18.

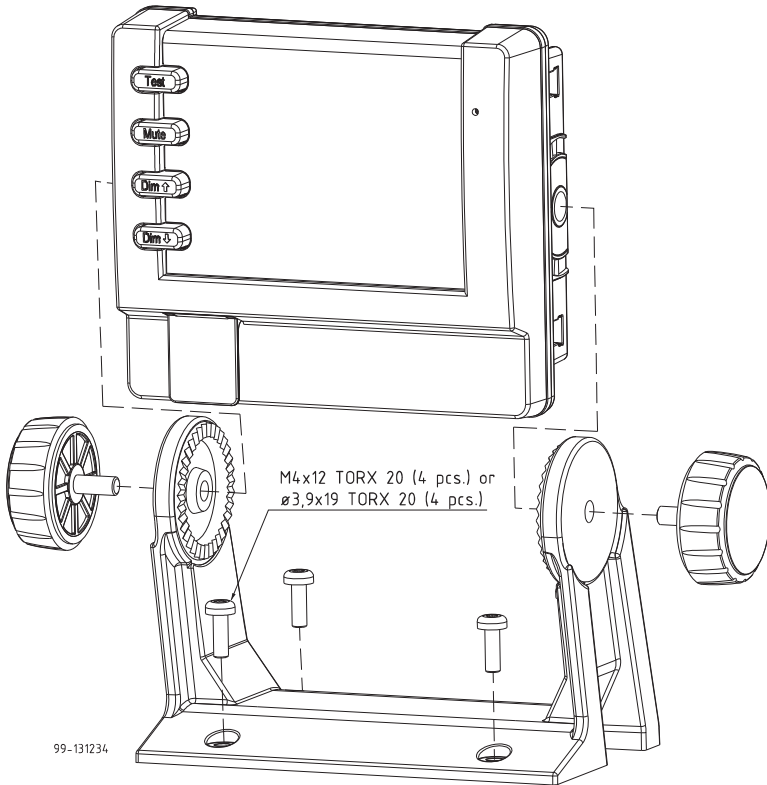

Overhead mounting

You can mount the Alarm Panel in an overhead position using the mounting bracket. For details on how to mount the Alarm Panel, see *Mounting the Alarm Panel with the mounting bracket* on page 18.

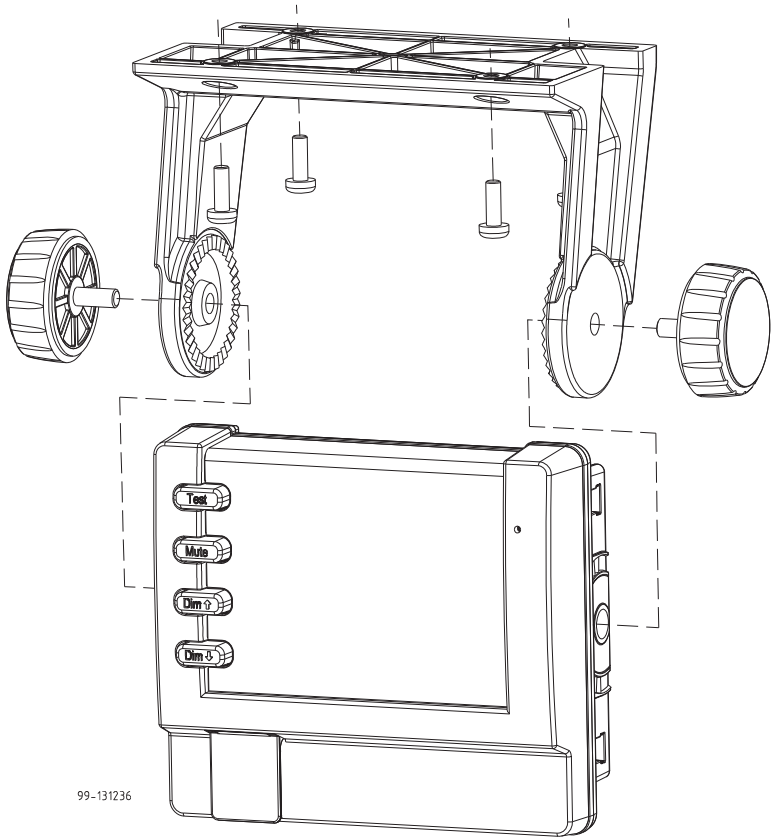

Mounting the Alarm Panel with the mounting bracket

To mount the Alarm Panel using the mounting bracket, do as follows:

1. Find a suitable location to mount the Alarm Panel. Make sure there is minimum 80 mm of free space for cable access behind the Alarm Panel.
2. Use the four holes to fasten the mounting bracket to the mounting surface. Screws are included with the mounting bracket.
3. Place the Alarm Panel in the mounting bracket.
4. Mount the two knobs on the sides of the bracket, but do not tighten them yet.
5. Connect the cables as described in *Connecting cables* on page 21.
6. Adjust the angle of the Alarm Panel to the wanted position. The bracket can be adjusted $\pm 20^\circ$.
7. Tighten the two knobs on the sides of the bracket when the Alarm Panel is in the correct position.

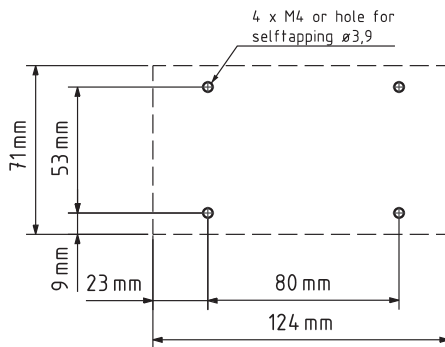
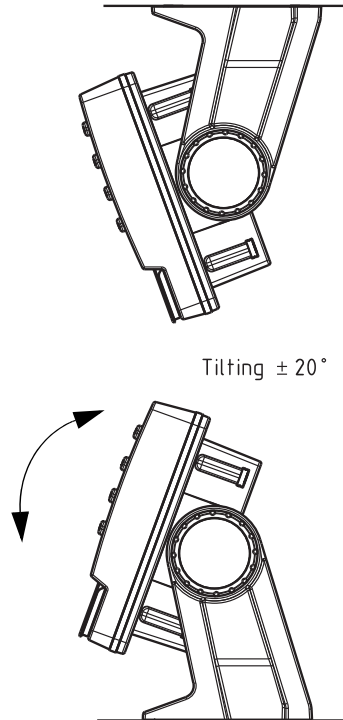

99-131233

Flush mount

You can mount the Alarm Panel in a flat surface, e.g. in a console, using the Flush mount bracket and screws included with the Alarm Panel.

To mount the Alarm Panel in a console, do as follows:

1. Find a suitable location in the console. Check that there is enough space for the Alarm Panel and an additional 80 mm space for cable entry.

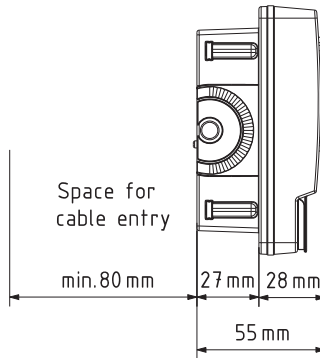

2. Cut a hole of 89 mm x 108 mm for the Alarm Panel.

Important

The scale in the below drawing is not 1:1! Do not use it as a template without checking the dimensions.

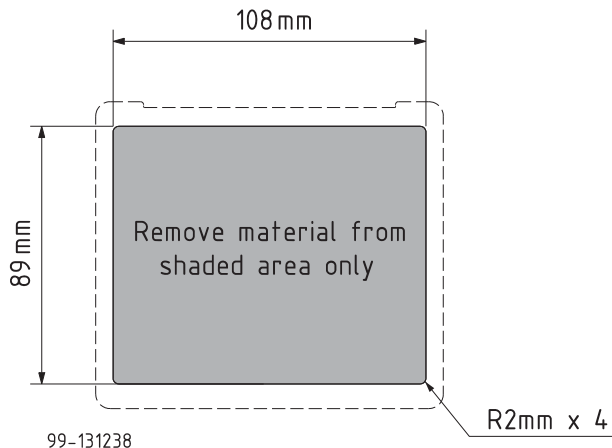

3. Place the 4 square nuts in the cut-outs on the sides of the Alarm Panel, two on each side.
4. Ensure that the flush mount gasket is placed correctly on the Alarm Panel.
5. Fit the Alarm Panel into the cut-out in the console.
6. Mount the flush mount bracket on the back of the Alarm Panel by mounting the 4 Torx screws through the bracket and into the square nuts placed in the Alarm Panel.

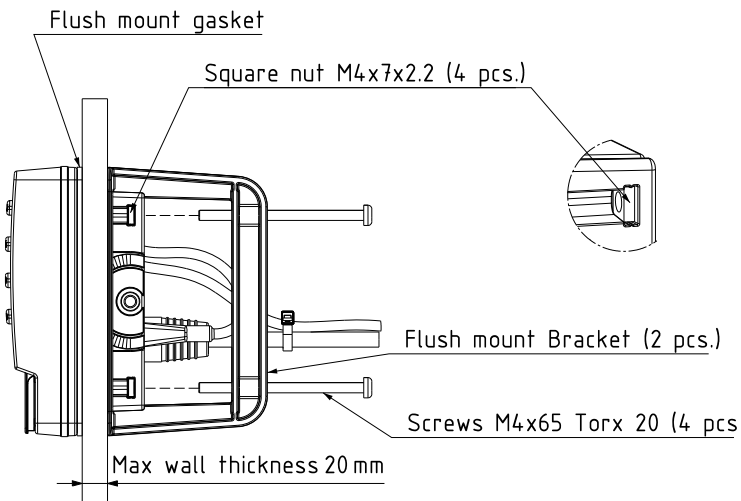

99-131239

7. Fasten the 4 Torx screws.
8. Connect the cables as described in *Connecting cables* on page 21.

Connecting cables

This chapter provides a description of all connectors on the Alarm Panel and gives guidelines to cabling. It has the following sections:

- *Connectors*
- *Cable requirements*
- *Connecting the Alarm Panel*
- *Connecting multiple Alarm Panels*

Connectors

Overview

The drawing below shows the connectors on the Alarm Panel.

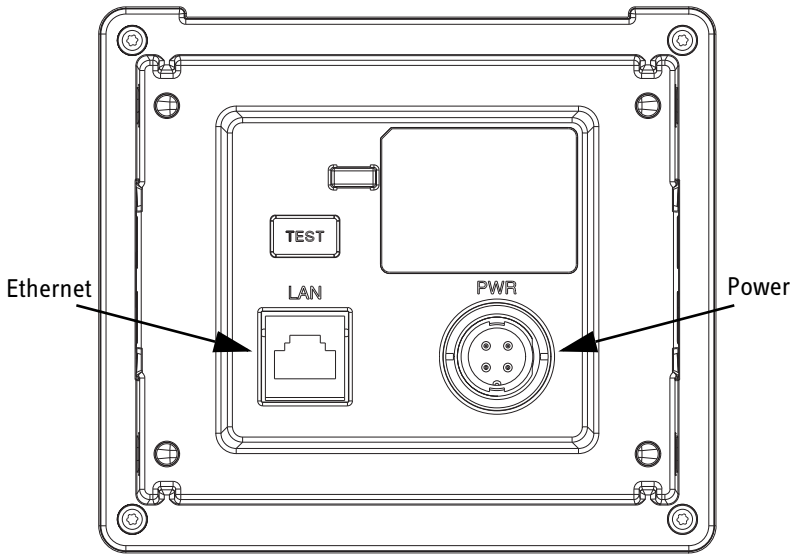

LAN interface

Overview

There is one Ethernet (10/100 MB) connector on the rear panel of the Alarm Panel, used for communicating with connected equipment, such as a Message Terminal, VHF and MF/HF equipment.

Important

Only connect to units that are part of the system. For safety and compliance reasons, the Ethernet interface is restricted to internal communication in an isolated system.

The interface supports PoE (Power over Ethernet), which means the Alarm Panel can be powered from a PoE device through the Ethernet.

Pin-out

The figure and table below show the connector outline and pin assignments.

Pin number	Pin function	
	10/100 DC on spares	10/100 mixed DC & data
1	Rx+	Rx+ DC+ (PoE)
2	Rx-	Rx- DC+ (PoE)
3	Tx+	Tx+ DC- (PoE)
4	DC+ (PoE)	unused
5	DC+ (PoE)	unused
6	Tx-	Tx- DC- (PoE)
7	DC- (PoE)	unused
8	DC- (PoE)	unused

RJ-45 female

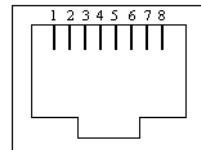

DC Power input

Overview

The DC Power input connects to a DC supply with 24 V DC nominal (10.8 to 32 V DC). The interface also has a “remote on/off” function.

Important

If you are **not** going to use the remote on/off function, you must connect pin 3 (ON_IN) to pin 2 (DC-) permanently.

The Power connector is a custom connector; a matching cable with connector is included in the delivery.

Pin-out

The figure and table below show the connector outline on the Alarm Panel, pin assignments and wire color in the power cable delivered with the Alarm Panel.

Pin number	Pin function	Wire color in power cable
1	DC+ (10.8 - 32 V DC)	Red
2	DC- (0 V DC)	Black
3	ON_IN (see below)	White
4	Not connected	Blue

Front view on Alarm Panel
Panel lock, 4 pin male

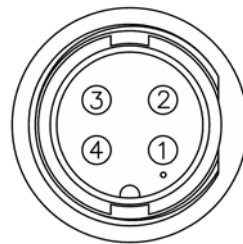

Remote on/off (ON_IN)

With the Remote on/off function you can switch the Alarm Panel on and off from a remote location, using a switch. Note that the Alarm Panel does not have a power button, so it is always on, unless you use the remote on/off function.

To use the Remote on/off function in the Alarm Panel, do as follows:

1. Connect a switch to the white wire in the power cable (pin 3, ON_IN, in the Power connector.)
2. Connect the other side of the switch to the black wire in the power cable (DC- (0 V DC) in the Power connector), so that pin 3 in the Power connector is connected to DC- (with a resistance less than 10 k Ω) when the switch is closed.
 - Switch closed: Alarm Panel is on
 - Switch open: Alarm Panel is off

Cable requirements

Before using the Alarm Panel for the first time, check that all cables are correctly wired and fastened.

Grounding

All cables attached to the Alarm Panel must be shielded.

- The shield of the Ethernet cable must be connected to ship ground in the Ethernet switch.
- The shield of the power cable must be connected to ship ground at the power supply.

Cable requirements

The power cable supplied with your system is 2.5 m long with AWG 16 wires and a custom connector at one end. If you are going to use another cable or extend the supplied cable, make sure the cables are dimensioned correctly. When the cable is connected to the power supply, there must be minimum 10.8 V at the end of the cable.

The Ethernet cable must be Cat. 5E or higher. Max. length is 100 m.

Connecting the Alarm Panel

This section covers both versions of the Alarm Panel, SAILOR 6101A and SAILOR 6103A.

To connect the Alarm Panel, do as follows:

1. Connect the power cable according to the description in *DC Power input* on page 24.
2. Connect an Ethernet cable to the LAN connector on the Alarm Panel.
3. Attach the cables with cable straps as shown below.

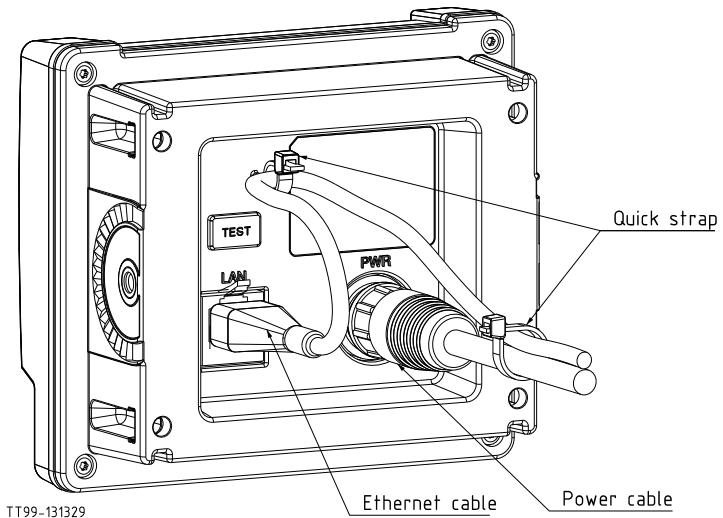

4. Connect the other end of the Ethernet cable to an Ethernet switch or alternatively a PoE switch.

Note

If you are using PoE as your power source for the Alarm Panel, the DC cable is optional.

5. Connect the Ethernet interfaces on your Message Terminal, VHF radio and/or your MF/HF radio to the same switch, or a switch in the same network.

Important

Only connect units that are part of the system. For safety and compliance reasons, the Ethernet interface is restricted to internal communication in an isolated system.

When connected and powered, all the units are automatically set up to communicate with each other in the Ethernet network.

Connecting multiple Alarm Panels

You can connect up to twelve Alarm Panels on the same subnet (e.g. six SAILOR 6101A and six SAILOR 6103A).

To connect multiple Alarm Panels, do as follows:

1. Connect the Alarm Panels to an Ethernet switch.
2. Connect the Ethernet switch to the system(s) used for transmitting the alarms, e.g. the Message Terminal in a Mini-C system or a VHF radio.

The units are automatically set up to communicate with each other in the Ethernet network.

Service and repair

This chapter describes what to do with defective units, including how to pack them for shipment if they are to be returned.

Introduction

The Alarm Panel designed to operate without preventive routine maintenance.

Although the Alarm Panel is designed and built very service friendly, we strongly recommend that any acting service technician is trained specifically on the product. Repair or repair attempts performed by unqualified personnel may limit the warranty. The warranty on the system is defined and outlined by the distributor that supplied the system.

We do not recommend repairing the Alarm Panel on board the ship. Replace the defective unit and have it repaired at a qualified workshop on shore.

For further information on warranty and service, you may also use the Thrane & Thrane home page at <http://www.thrane.com>.

Repacking for shipment

The shipping carton has been carefully designed to protect the Alarm Panel and its accessories during shipment. This carton and its associated packing material should be used when repacking for shipment. Attach a tag indicating the type of service required, return address, model number and full serial number. Mark the carton FRAGILE to ensure careful handling.

If the original shipping carton is not available, the following general instructions should be used for repacking with commercially available material.

1. Wrap the Alarm Panel in heavy paper or plastic. Attach a tag indicating the type of service required, return address, model number and full serial number.
2. Use a strong shipping container, e.g. a double walled carton of 160 kg test material.
3. Protect the front- and rear panel with cardboard and insert a 7 cm to 10 cm layer of shock-absorbing material between all surfaces of the equipment and the sides of the container.
4. Seal the shipping container securely.
5. Mark the shipping container FRAGILE to ensure careful handling.

Specifications

General specifications

Item	Specifications
Mounting method	Flush mount or bracket
Power	10.8 to 32 V DC, with “remote on/off” input
Power Consumption	Typical 1 W, Maximum 3 W
Interfaces	Ethernet (10/100 Mbit), RJ45 connector DC input, custom panel lock connector
Compliance	<ul style="list-style-type: none"> • IEC 60945 • Wheelmark approved.
IP protection	IP30
Ambient Temperature	-15°C to 55°C
Storage temperature	-40°C to 80°C
Relative humidity	+40°C 93% 1 cycle

Appendix A: Specifications

Item	Specifications
Vibration	Vibration Sweep: 2 Hz - 13,2 Hz at ± 1 mm 13,2 Hz - 100 Hz at $7m/s^2$ 2 h dwell at each resonance, otherwise 2 h at 30Hz in all three axes
Compass safe distance	1 m
Dimensions H x W x D	Without bracket: 107 mm x 121 mm x 55 mm With bracket: 124 mm x 153 mm x 90 mm
Weight	Without bracket: 302 g

A

AWG American Wire Gauge. A means of specifying wire diameters.

D

DC Direct Current

G

GMDSS Global Maritime Distress Safety System. The system is intended to perform the following functions: alerting (including position determination of the unit in distress), search and rescue coordination, locating (homing), maritime safety information broadcasts, general communications, and bridge-to-bridge communications.

H

HF High Frequency. Radio frequencies between 3 and 30 MHz. Used for direct, long-distance (often inter-continental) communications.

I

IMSO International Maritime Satellite Organisation. An intergovernmental body established to ensure that Inmarsat continues to meet its public service obligations.

Inmarsat C A service provided by Inmarsat, offering two-way, store-and-forward packet data communications via a small, low-cost terminal. Handles operational and personal messages, including e-mail, telex and fax, as well as distress and safety communications.

IP Ingress Protection. An international classification system for the sealing effectiveness of enclosures of electrical equipment against the intrusion into the equipment of foreign bodies (i.e. tools, dust, fingers) and moisture. This classification system uses the letters "IP" followed by two or three digits. An "x" is used for one of the digits if there is only one class of protection; e.g. IPX4 which addresses moisture resistance only.

M

MF Medium Frequency. Radio frequencies (RF) in the range of 300 kHz to 3 MHz. Navtex, which is part of the current Global Maritime Distress Safety System occupies 518 kHz and 490 kHz for important digital text broadcasts.

P

PoE Power over Ethernet. A standard for combining power supply with transmission of data over the Ethernet. The source unit "injects" power into the Ethernet cable and the power is "picked up" at the connected device.

R

Rx Receive

T

Tx Transmit

V

VHF Very High Frequency. The radio frequency range from 30 MHz to 300 MHz. Ideal for short-distance terrestrial communication.

A

- Alarm Panel
 - description, 2
 - Multi, 3
 - types of, 1

C

- cable requirements, 26
- connectors
 - DC power input, 24
 - LAN, 23
 - overview, 22

D

- DC power input connector, 24
- desktop mounting, 16
- dim function, 11
- dimensions, 32
- distress
 - sending alert, 7
- distress message indication, 8
- document number
 - this manual, i

E

- Ethernet connector, 23

F

- faults
 - indication in display, 9
- flush mount, 19

I

- indication
 - faults in connected equipment, 9
 - incoming messages, 8
- initial inspection, 14
- Inmarsat C Alarm Panel, 2
- installation, 15

L

- LAN connector, 23
- light
 - adjusting, 11

M

- manual
 - document number, i
 - message received indication, 8
 - mounting
 - flush mount, 19
 - on desktop, 16
- Multi Alarm Panel description, 3
- muting alarm sound, 10

P

- power input connector, 24

R

- receiving distress or urgency messages, 8
- repacking for shipment, 30
- repair, 29

returning units, 30

S

safety summary, iii

SAILOR 6101A description, 2

SAILOR 6103A description, 3

service, 29

specifications, 31

storage, 14

T

test of Alarm Panel, 10

types of Alarm Panel, 1

U

unpacking, 14

urgency message indication, 8