

AVIATOR 700/700D

User manual



AVIATOR 700/700D

User Manual

Document number: 98-130578-D

Release date: June 22, 2018

Disclaimer

Any responsibility or liability for loss or damage in connection with the use of this product and the accompanying documentation is disclaimed by Thrane & Thrane A/S. The information in this manual is provided for information purposes only, is subject to change without notice and may contain errors or inaccuracies. Manuals issued by Thrane & Thrane A/S are periodically revised and updated. Anyone relying on this information should acquire the most current version e.g. from www.cobham.com/satcom, **Cobham SYNC Partner Portal**, or from the distributor. Thrane & Thrane A/S is not responsible for the content or accuracy of any translations or reproductions, in whole or in part, of this manual from any other source. In the event of any discrepancies, the English version shall be the governing text.

Thrane & Thrane A/S is trading as Cobham SATCOM.

Copyright

© 2018 Thrane & Thrane A/S. All rights reserved. Printed in Denmark.

Company address

Thrane & Thrane A/S, Lundtoftegaardsvej 93 D, DK-2800, Kgs. Lyngby, Denmark

Trademark acknowledgements

- **Inmarsat** is a registered trademark of the International Maritime Satellite Organisation (IMSO) and is licensed by IMSO to Inmarsat Limited and Inmarsat Ventures plc.
- **Windows** and **Outlook** are registered trademarks of Microsoft Corporation in the United States and other countries.
- **WinPoET** is a trademark of Fine Point Technologies, Inc.
- Other product and company names mentioned in this manual may be trademarks or trade names of their respective owners.

Company web site

www.cobham.com/satcom

Safety summary

The following general safety precautions must be observed during all phases of operation, service and repair of this equipment. Failure to comply with these precautions or with specific warnings elsewhere in this manual violates safety standards of design, manufacture and intended use of the equipment. Thrane & Thrane A/S assumes no liability for the customer's failure to comply with these requirements.



RADIATION WARNING

During transmission the antenna radiates Microwave power. High levels of radio frequency radiation are considered harmful to health. Although no single value has been agreed upon by all countries, the American National Standards Institute (ANSI/IEEE C95.1-1992) recommends that people should not be exposed to radiation stronger than 1 milli Watt per square centimeter at the frequencies used in this system. Accordingly, the operator of the system should ensure that no person should approach within 200 cm from the sides and above the satcom antenna when the system is transmitting.

Radio frequency radiation exposure information:

This equipment complies with FCC radiation exposure limits set forth for an uncontrolled environment. This equipment should be installed and operated with minimum distance of 200 cm between the radiator and your body. This transmitter must not be co-located or operating in conjunction with any other antenna or transmitter.

Antenna mounting

The antenna supplied by the manufacturer must be located such that during radio transmission, no person or persons can come closer than the minimum safe distance stated in the Radiation warning above. To comply with current FCC RF Exposure limits, the antenna must be installed at or exceeding the minimum safe distance shown above, and in accordance with the requirements of the antenna manufacturer or supplier.

Disposal

Old electrical and electronic equipment marked with this symbol can contain substances hazardous to human beings and the environment. Never dispose these items together with unsorted municipal waste (household waste). In order to protect the environment and ensure the correct recycling of old equipment as well as the re-utilization of individual components, use either public collection or private collection by the local distributor of old electrical and electronic equipment marked with this symbol.



Contact the local distributor for information about what type of return system to use.

About the manual

Intended readers

This manual is a user manual for the AVIATOR 700 System. The readers of this manual include aircraft personnel and passengers who want to use Classic Aero, SwiftBroadband and Swift64 services.

For the daily use of the system there are no specific skills required. However, it is important that you observe all safety requirements listed in this manual, and operate the system according to the guidelines in this manual.

Note

The AVIATOR 700 system is available in two versions:

AVIATOR 700 approved to RTCA specification DO- 178B level E and DO-254 level E

AVIATOR 700D approved to RTCA specification DO-178B level D and DO-254 level D.

In general descriptions the nomenclature AVIATOR 700 covers both versions. Where necessary, the Level D system is specified as AVIATOR 700D.

Manual overview

The manual contains the following chapters:

- **Introduction** - an overview of the Inmarsat Aero system and its services. Also a brief description of the AVIATOR 700 system.
- **Get started** - a description of how to start up the system.

- **Calls, faxes and SMS** - a detailed description how to make calls, from the Full Feature handsets or the MCDU (Multi-function Control and Display Unit, how to send faxes and how to send and receive text messages. Also a short description of other handsets.
- **Use a computer** – a description of how to connect and set up a computer for using SwiftBroadband or Swift64 data services, including LAN and WLAN connection, ISDN and MPDS connections, PPPoE and analog modem connection.
- **System operation** with setup information for the Full Feature handset, MCDU and the SwiftBroadband Unit.
- **Troubleshooting** – a short troubleshooting guide, a description of system LEDS and error messages that may appear during operation. Also a list of H⁺ Cause codes and information on where to get further help if necessary.

Note that this manual does not cover the installation, configuration and setup of the system. It does neither cover how to customize the system for specific applications. For more detailed information how to set up interfaces and configure network setup and routing functionality see the AVIATOR 700 Installation and maintenance manual.

You find the part numbers for related manuals in *Related documents* on the next page.

This manual may not always reflect the latest software functionality of your AVIATOR 700 system. To obtain the latest version of the manual, please enter the Cobham SATCOM web site at: www.cobham.com/satcom, select **Cobham SYNC Partner Portal** and download the latest version, or acquire it from your distributor.

Software version

This manual describes the following:

AVIATOR 700 (**Level E**) with the following software:

- SBU: AVIATOR 700: 1.09 (Level E) or greater
- SDU: AVIATOR 700: 1.15 (Level E) or greater

The software used to control the unit operation complies with RTCA specification DO-178B level E application software.

The firmware used to control the unit operation complies with RTCA specification DO-254D level E firmware.

AVIATOR 700 (**Level D**) with the following software:

- SBU: AVIATOR 700D: 2.02 (Level D) or greater
- SDU: AVIATOR 700D: 2.01 (Level D) or greater

The software used to control the unit operation complies with RTCA specification DO-178B level D application software.

The firmware used to control the unit operation complies with RTCA specification DO-254D level D firmware.

Related documents

The below list shows the documents related to this manual and to the AVIATOR 700 system:

Title and description	Part number
AVIATOR 700 Quick Guide containing short instructions for the daily use of the system.	98-130554
AVIATOR 700 Installation and Maintenance Manual containing detailed information needed to install and configure the AVIATOR 700 system in the aircraft.	98-124743
AVIATOR Wireless Handset and Cradle, User Manual	98-129599
AVIATOR Wireless Handset and Cradle, Installation and Maintenance Manual	98-129600
Swift64 and H⁺ Data Service , Supplement to AVIATOR 700 and HSD ⁺ User Manual, available for download.	98-132721

Typography

In this manual, typography is used as indicated below:

Bold is used for the following purposes:

- To emphasize words.
Example: “Do **not** touch the antenna”.
- To indicate what the user should select in the user interface.
Example: “Select **SETTINGS > LAN**”.

Italic is used to emphasize the paragraph title in cross-references.

Example: “For further information, see *Connecting Cables* on page...”.

Table of contents

	About the manual	iv
Chapter 1	Introduction	
	System description	2
	AVIATOR 700 system	3
	AVIATOR 700 Features	4
	AVIATOR 700 Services	4
	AVIATOR 700 Interfaces	6
	AVIATOR 700 system parts	9
	Aero services — background information	15
	Call and data services	15
	Satellite coverage maps	17
	Background information, SwiftBroadband services	19
	Background information, Classic Aero and Swift64 services ..	21
Chapter 2	Get started	
	Logon procedure	25
	Logon procedure with the Full Feature handset	25
	Logon procedure with the MCDU	26
	Connect a computer	27
	Internet, e-mail, etc.	27
	Make the first call	29
	Make a call (air to ground)	29
	Call a handset in the aircraft (ground to air)	29
	Send a fax	32
	Send a fax via SBU	32
	Send a fax via SDU	32
	To power off the satcom system	32

Chapter 3 Calls, faxes and SMS

Introduction	33
Use a phone or fax machine (SDU)	34
Available interfaces (SDU)	34
Select a call type (SDU)	34
Make or receive a phone call (SDU)	37
Send or receive a fax message (SDU)	44
Use a phone or fax machine (SBU)	46
Available interfaces (SBU)	46
Select a call type (SBU)	46
Make or receive a phone call (SBU)	49
Send or receive a fax message (SBU)	60
Operate the handsets	62
Operate the Full Feature handset	62
How to make calls from the Full Feature handset	71
Operate the Auxiliary handset	73
How to make calls from the Auxiliary Handset	76
How to make a call with the Sigma ⁷ handset	79
How to make a call with the 2.4GHz Cordless handset	80
How to make a call from an ISDN phone	80
Operate the AVIATOR Wireless Handset	80
Use a SIP-enabled IP handset (SBU)	81
Use the MCDU	83
Operate the MCDU	83
Make or receive a phone call (MCDU)	87
SMS service	94
Introduction	94
Handle messages	96
Configure message settings	99

Chapter 4 Use a computer

Use a computer over SwiftBroadband	101
Tool for setup and use: The web interface	101
Services and interfaces	103
LAN and WLAN interfaces	104
Customize network use	104
Network user groups	105
Connect to the Internet	106
Use a computer over Swift64	112

Chapter 5 System operation

Full Feature handset operation (SDU)	113
Access and exit menus	114
Restricted access	114
Use the SDU phone book	115
Handset Setup	117
Ring Profile	122
Lock System	123
Logon Menu	124
System Setup	130
System Setup, Ring Profiles	133
System Setup, Quick Dial	135
System Setup, Pin Setup	136
System Setup, Configure	138
Status	143
Maintenance (reset)	148
MCDU operation	149
Operate the MCDU	149
AVIATOR 700 main menu	150
SUBMENU	151
LOCK menu	152
LOGON menu	153
SYSTEM menu	156
STATUS menu	160

Use the SBU web interface	164
Introduction to the SBU web interface	164
Use the SBU phone book	173
Use the Call log	176
View the lists of calls	177
Start or stop any data session	179
Call log handling	180
Set data limits	181
Set up the local exchange function	182
Remote management and activation	183
Prepare the AVIATOR 700 for remote management	183
Access the AVIATOR 700 from a remote location	184
Remote activation of the SBU with SMS	185
Restricted dialing	187

Chapter 6 Troubleshooting

Get support	189
Airtime support	189
System support	189
SDU errors	190
Error messages	190
List of H ⁺ Cause codes	192
SBU errors	198
Access the Help desk	198
Generate a diagnostic report	199
Event log and self test	199
SBU Troubleshooting guide	200
System LEDs	206
SDU LEDs	206
HPA LEDs	207
SBU LEDs	208

App. A Menu trees







Menu tree for the Full Feature handset	212
Menu tree for the MCDU	213
Menu tree for the SBU	214

App. B	List of available GESs	
App. C	Conformity	
	FCC	217
	15.19 / RSS-GEN	217
	15.21	217
	15.105	217
	ICES-003	218
Glossary	219
Index	225

Introduction

Congratulations on the purchase of your AVIATOR 700 system. It provides simultaneous high-speed data and voice communication via satellite through Inmarsat's SwiftBroadband and Classic Aero services.

See the table below to see the cabin applications that are available.

Telephone (secure)	Internet E-mail	Wireless access point	Built-in router	Messaging service	ISDN	Fax
						

For instructions how to install and set up the system see the Installation and Maintenance Manual.

In this chapter

In this chapter you can read about:

- *System description*
- *Aero services — background information*

System description

The AVIATOR 700 is a unique multi-channel solution. It combines global voice, fax and data capabilities of the Inmarsat Classic Aero, SwiftBroadband and Swift64 service.

These service classes are available on two satellite types: the I4 and I3 satellites. The AVIATOR 700 system supports both types and manages automatic satellite hand-over between the satellites. This means 100% worldwide coverage for data and phone services.

Note

The Classic Aero services are available on both I3 and I4 satellites, while data services using SwiftBroadband are available exclusively on I4 satellites. The AVIATOR 700 system uses Swift Broadband for data services whenever possible. Swift64 is used as a fallback solution for areas where SwiftBroadband is not available.

For detailed information on services and coverage maps see *Aero services — background information* on page 15.

AVIATOR 700 system



AVIATOR 700 Features

The AVIATOR 700 system has the following features:

- Cockpit audio dialing from MCDU
- Cockpit data channel
- Interface to ACARS, AFIS and CMU
- Data rates up to 432 kbps
- VoIP connectivity
- Wired and wireless web browsing and corporate VPN access
- Wireless use of PDA and Smart Phones
- Low cost and high quality voice service
- Built-in router for intelligent connectivity support and multiple user support
- Built-in Ethernet switch for supporting multiple wired lap tops
- Built-in wireless LAN for supporting multiple wireless devices
- Built-in Multi-voice option, up to 1 + 8 concurrent calls
- 2 built-in PBX for supporting multiple handsets
- ISDN connectivity

AVIATOR 700 Services

The following table gives an overview of the services available for Inmarsat services Classic Aero, SwiftBroadband and Swift64.

Note

The devices in the cabin must be connected to the correct unit, the Satellite Data Unit (SDU) or the SwiftBroadband Unit (SBU), to support the individual services. See *AVIATOR 700 Interfaces* on page 6.

Typically the system will log on to an I4 satellite where Classic Aero and SwiftBroadband are available. SwiftBroadband handles all Swift64 services and more.

For background information on these services, see *Background information, SwiftBroadband services* on page 19 and *Background information, Classic Aero and Swift64 services* on page 21.

Services	I4 satellite	I3 satellite	Inmarsat service
Voice service	√	√	Classic Aero (H ⁺)
2.4 kbps modem/fax	√	√	
Low speed data (600 or 1200 bps) for CMU, AFIS and ACARS	√	√	
IP background service (up to 432 kbps)	√		Swift Broad-band (SBB)
IP streaming service (8/16/32/64/128 kbps/X-Stream)	√		
Standard voice (AMBE call)	√		
ISDN UDI 64 kbps	√		
ISDN RDI 56 kbps	√		
High quality audio service (3.1 kHz (14.4 kbps) for modems, G3 fax etc.)	√		
High-quality voice	√		
Built-in router option with DHCP and Network Address Translation (NAT)	√		
Built-in wireless option	√		

Services	I4 satellite	I3 satellite	Inmarsat service
IP/MPDS background service (up to 64 kbps)		√	Swift64 (SW64, HSD)
ISDN UDI 64 kbps		√	
ISDN RDI ^a 56 kbps		√	
High quality audio service (3.1 kHz (14.4 kbps) for modems, G3 fax etc.)		√	
High-quality voice (speech)		√	

- a. Check with your service provider that the RDI service is available on the Ground Infrastructure network.

AVIATOR 700 Interfaces

The following table shows the interfaces of the AVIATOR 700 system. Check with your system responsible for interfaces available in your aircraft.

Note

The devices in the cabin must be connected to the correct unit, the Satellite Data Unit (SDU) or the SwiftBroadband Unit (SBU), to support the individual services.

Interfaces	I4 satellite	I3 satellite	Via
Full feature handset (4-wire) for voice service (low cost) or 3.1 kHz high quality audio service	4	4	SDU
Telephone handsets (2-wire) for voice service (low cost) or 3.1 kHz high quality audio service	2	2	
MCDU (Cockpit)	2	2	
ARINC 429 (Low speed data 1.2 kbps for AFIS, ACARS, CMU) (Cockpit)	1	1	
ISDN	—	1	
Ethernet interfaces for PC etc. (MPDS via PPPoE) and external router	—	1	
RS-422 / RS-232 for MPDS via PPP, UDI and RDI ^a	—	1	
Ethernet interfaces for PCs etc.	6	—	SBU
Built-in wireless access point for background data and streaming services	1	—	
ISDN	1	—	
Telephone handsets (2-wire) for voice service (low cost) or 3.1 kHz high quality audio service	2	—	

- a. Check with your service provider that the RDI service is available on the Ground Infrastructure network.

Non-Safety interfaces (Level E)

The following interfaces are strictly for non-safety usage:

- Cockpit audio
- ACARS/AFIS/CMU (information and management systems)
- MCDU (Multifunction Control and Display Unit)

Safety interfaces (Level D)

The following interfaces are approved for safety usage:

- Cockpit audio
- ACARS/AFIS/CMU (information and management systems)
- MCDU (Multifunction Control and Display Unit)

Built-in router and Wireless options

The SwiftBroadband Unit of the AVIATOR 700 system offers a built-in router as an option. With this option you can connect multiple computers, and several applications can use the system simultaneously. The system also offers a built-in Wireless option for wireless communication devices using a WLAN antenna approved for aeronautical use.

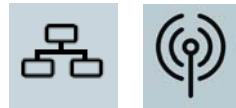

These options are enabled in the AVIATOR 700 by a FLEX key entered during system configuration, typically at Thrane & Thrane. If not, you can upgrade your system at a later stage. For upgrade instructions see the *AVIATOR 700 Installation and Maintenance Manual containing detailed information needed to install and configure the AVIATOR 700 system in the aircraft.*

PBX telephone exchanges

The AVIATOR 700 system has two built-in independent PBX units:

- PBX in the Satellite Data Unit (SDU)
- PBX in the SwiftBroadband Unit (SBU)

See the overview in *AVIATOR 700 Interfaces* on page 6 for information on which types and how many phones can be connected to each PBX. You can route calls to handsets connected to the same PBX (SDU or SBU).

Note

Call routing between the two PBX units is not supported.

The devices in the cabin must be connected to the correct unit, the Satellite Data Unit (SDU) or the SwiftBroadband Unit (SBU), to support the individual services.

A call incoming on the SDU can be routed to a handset marked SDU, a call incoming on the SBU can be routed to a handset marked SBU.

You can also connect the AVIATOR Wireless Handset.

If you have an IP phone or Smart Phone that has a SIP client, you can use the integrated SIP server of the SBU. For instructions see *To set up a SIP-enabled wireless IP handset (SBU)* on page 81.

AVIATOR 700 system parts

The AVIATOR 700 system comprises the following parts:

- *TT-5035A Satellite Data Unit (SDU) and TT-5014A High Power Amplifier (HPA)*
- *TT-5040A SwiftBroadband Unit (SBU)*
- *Handsets*
- *Multifunction Control and Display Unit (MCDU) (optional)*
- *Web interface for SBU control*

TT-5035A Satellite Data Unit (SDU) and TT-5014A High Power Amplifier (HPA)

The SDU is the controlling unit of the satcom system. A Configuration Module (CM) and all the interfaces, except for the maintenance port, are located on the rear of this unit.

The High Power Amplifier (HPA) connects to the satcom antenna and amplifies the transmission signals of all channels simultaneously.



TT-5040A SwiftBroadband Unit (SBU)

The SwiftBroadband Unit (SBU) provides access to the SwiftBroadband services. A Configuration Module (CM) and all the interfaces, except for the maintenance port, are located on the rear of this unit.



Handsets

TT-5620A Full Feature handset and TT-5622A Full Feature cradle

The Full Feature handset is used to make and receive calls and to control, view status information and configuration data of parts of the AVIATOR 700 system, including the SDU.

See *Operate the Full Feature handset* on page 62 for a description of keys, LEDs and display of the Full Feature handset and *How to make calls from the Full Feature handset* on page 71 how to make calls.



AVIATOR Wireless Handset and Cradle

The AVIATOR Wireless Handset is used to make phone calls over an IP based network. The handset connects to a wireless access point using a Wireless Local Area Network (WLAN).



See the *AVIATOR Wireless Handset and Cradle, User Manual* for a description of the keys and LEDs of this handset and how to make calls.

TT-5621B Auxiliary handset and TT-5622B Auxiliary cradle

The Auxiliary handset is used to receive and to make calls.

See *Operate the Auxiliary handset* on page 73 for a description of the keys and LEDs of the Auxiliary handset and how to make calls.



Sigma⁷ handset and cradle

The Sigma⁷ handset is used to receive and to make calls.

See *How to make a call with the Sigma⁷ handset* on page 79 for a description of how to use the Sigma⁷ handset and how to make calls.



2.4GHz Cordless handset

The 2.4GHz Cordless handset system is used to receive and to make calls.

See *How to make a call with the 2.4GHz Cordless handset* on page 80 for a description of how to use the 2.4GHz Cordless handset and how to make calls.



Multifunction Control and Display Unit (MCDU) (optional)

An MCDU can be used to make and receive calls and to access the AVIATOR 700 menu system for control and configuration of the satcom system from the cockpit. A subset of the MCDU menus and functions are identical to those of the Full Feature handsets.

With the cockpit audio interface, which connects to the pilot headset via the cockpit Audio Management System, the pilot can make calls from the cockpit without using a handset.

See *Use the MCDU* on page 83 for a description of how to use the MCDU.



(Example)

Web interface for SBU control

Use the built-in web interface of the SwiftBroadband Unit (SBU) to access the system settings. The web interface is accessed from a computer connected to one of the LAN connectors or using the WLAN interface of the SBU. The web interface is shown in an Internet browser. No additional installation of software is needed.

See *Introduction to the SBU web interface* on page 164 for a description of how to use the web interface.

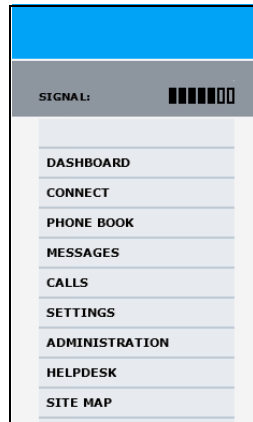

Aero services — background information

Call and data services

The geostationary satellites are your connection to the Internet and telephone networks. They are situated above the equator. Geostationary means that the satellites are stationary in relation to Earth, i.e. they rotate at a speed that matches the rotation speed of the Earth. The satellites are run and managed by Inmarsat. Inmarsat is the leading provider of global mobile communications services. Inmarsat keeps track of which units are logged on to the system, assigns a free channel and manages the data when a network connection is established or a call is made.

With the AVIATOR 700 system you can use the services **SwiftBroadband**, **Classic Aero** and **Swift64**. They are accessible worldwide, except the extreme polar regions. They are represented on the following satellite types:

- **SwiftBroadband**: Four I4 satellites
- **Classic Aero**: Four I4 satellites and four I3 satellites
- **Swift64**: Four I3 satellites

Satellite type	Short name	Full name
I4	AMER	Americas
	MEAS	Middle East and Asia
	APAC	Asia Pacific
	EMEA (Alphasat)	Alphasat (covers Europe, Middle East and Africa)
I3	AORE	Atlantic Ocean Region East
	POR	Pacific Ocean Region
	IOR	Indian Ocean Region
	AORW	Atlantic Ocean Region West

Each satellite covers a certain area (footprint) and supports a number of powerful spot-beams making the service available virtually anywhere on Earth between approximately 70°N and 70°S.

For coverage maps of the satellites see *Satellite coverage maps* on page 17.

Note

Some of the services are available on the interfaces of the SDU, others on the SBU. See *AVIATOR 700 Interfaces* on page 6 and check your cabin installation for interfaces available in your installation.

For uses of these services see *AVIATOR 700 Services* on page 4.

SwiftBroadband

The Aero SwiftBroadband services are available on four I4 satellites. Each of these covers a certain area, this is also called a footprint, supporting a number of powerful narrow-spot-beams making the SwiftBroadband service available virtually anywhere on the earth.

Classic Aero

The Inmarsat Classic Aero (also called H⁺) services are available on four I3 satellites and four I4 satellites.

Swift64

The Inmarsat Swift64 (also called High Speed Data or HSD) services are available on four I3 satellites. This service is used as a fallback solution when the primary data service, SwiftBroadband, is not available.

Note

The ISDN (Integrated Services Digital Network) and MPDS (Mobile Packet Data Service) services are only available when the aircraft is positioned inside an area with Spot Beam coverage.

Satellite coverage maps

The AVIATOR 700 system is typically configured to automatic logon to the satellite services after power up. The system supports automatic satellite hand-over when the aircraft moves out of the coverage area for the current satellite, ensuring permanent coverage by either I4 or I3 satellites. In areas with no I4 satellite coverage, the system will fall back to an I3 satellite. When the system moves back into I4 coverage, the hand over to an I4 satellite takes place as soon as there are no active Classic Aero or Swift64 calls.

The following figure shows coverage of SwiftBroadband and Classic Aero services on I4 satellites.

Inmarsat's I4 satellite coverage (AMER, MEAS, APAC, EMEA/Alphasat)

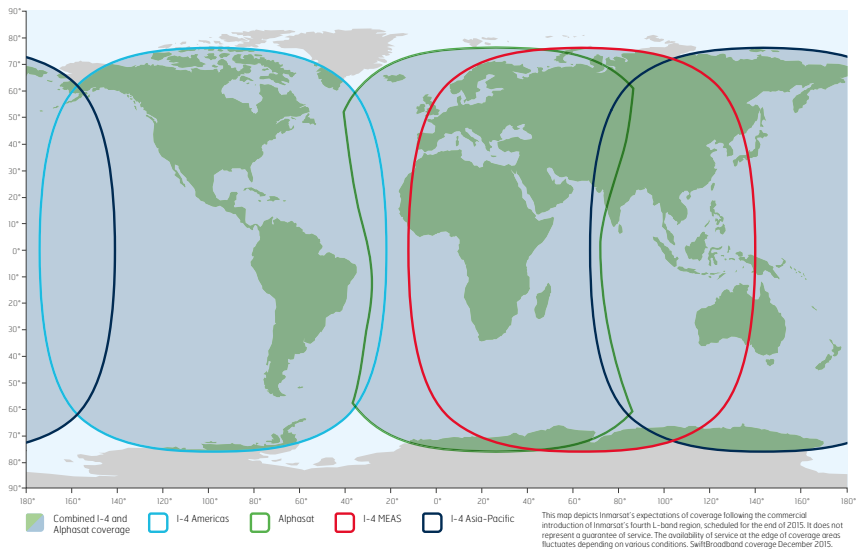

Note

The map above shows Inmarsat's SwiftBroadband services coverage. The map does not represent a guarantee of service. The availability of service at the edge of coverage areas may fluctuate.

The following figure shows coverage for Classic Aero and Swift64 services on 13 satellites.

Swift64 and Classic aeronautical services coverage (IOR, POR, AORE, AORW)

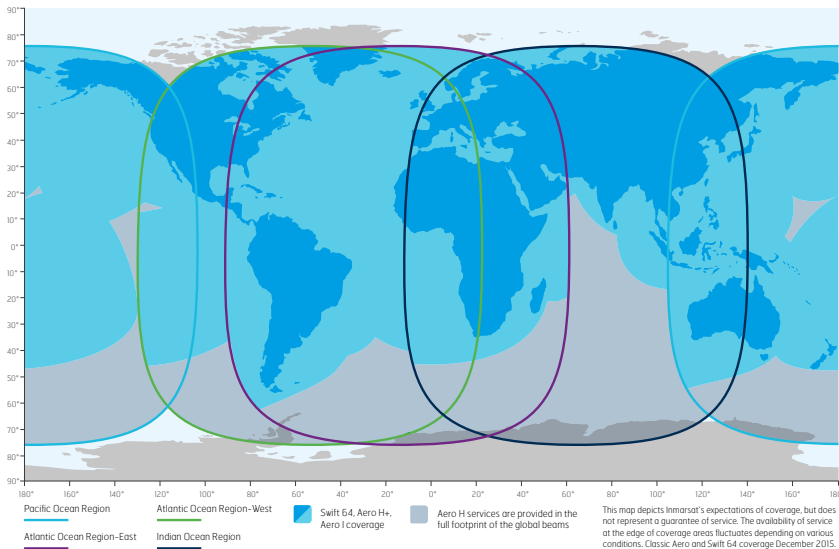

Note

The map above shows Inmarsat's Swift64 and Classic Aero services coverage. The map does not represent a guarantee of service. The availability of service at the edge of coverage areas may fluctuate.

Earth Stations for Classic Aero services and Swift64

The gateway between the public network and the satellites is operated by a Land Earth Station (LES) for the Swift64 data communication or Ground Earth Station (GES) for the global voice, fax and low-speed data capabilities. The LESs and GESs are run by different operators around the world.

Background information, SwiftBroadband services

SwiftBroadband offers the basic services:

- Symmetric 'always on' data connection, packet switched (PS)
- Voice and ISDN (voice and data) service, circuit switched (CS)
- Short Messaging Service (SMS) in the AVIATOR 700 system

The following figure shows how the services are accommodated in a SwiftBroadband channel.

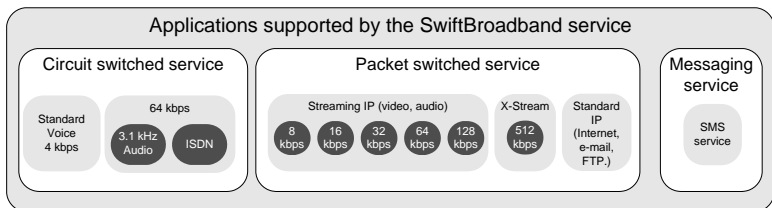

With SwiftBroadband you can combine multiple packet-switched services with one circuit-switched service active at the same time

Note

The SwiftBroadband system only supports one circuit-switched call at a time per AVIATOR 700 system.

Circuit switched (dialed) service

SwiftBroadband also provides high-quality telephone services (including secure mode). The following types of circuit switched connection are available:

- **Standard voice.** A low-cost connection for voice only. The voice signal is compressed to 4.0 kbps, which reduces the bandwidth use and consequently the cost. This is also called AMBE.
- **3.1 kHz audio.** A high quality connection which can be used for Premium Voice, G3 fax or analog modems. The signal is uncompressed 3.1 kHz audio, which allows for optimum voice quality.
- **ISDN.** A high quality connection which can be used for voice (3.1 kHz Audio), G4 fax or 64 kbps UDI/RDI data.

Packet switched service

The IP-based packet-switched service provides a data rate of up to 432 kbps. The packet switched service offers two types of connection: In **Standard IP** mode, the service is shared among users of the system, providing a 'best effort' service. This type of connection is ideal for e-mail, file transfer, and Internet and intranet access. The user pays for the data sent and received. This type of connection is also called Background IP.

You can also use the SwiftBroadband service at a pre-determined quality of service, i.e. with a specified streaming data rate. This service is called **Streaming IP**. This type of connection is ideal for time critical applications like live video over IP. The user pays for the duration of the connection (per minute charge)

Note

The SBU of the AVIATOR 700 supports up to 11 concurrent packet-switched connections at a time. For use of packet switched services also see *AVIATOR 700 Services* on page 4.

Messaging service

SwiftBroadband provides a generic messaging service for sending and receiving messages to and from the AVIATOR 700 system.



Supplementary telephone services

The following supplementary telephone services are available:

- Call hold
- Call waiting
- Call forwarding
- Conference call (Multi-party calls)
- Voice mail
- Call barring

These services are typically set up during the initial configuration of the system. For further details on Call forwarding see *To forward a call (SBU)* on page 58, the other supplementary telephone services are described in detail in the AVIATOR 700 Installation and maintenance manual.

Airtime pricing principles

When using the connections of your system note that the circuit switched services and streaming classes (packet switched) are charged by the **time** the service is being used, while the standard IP and SMS services (packet switched) are charged by the **volume of data** transferred.

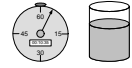

The following image shows how the various applications are supported by the SwiftBroadband service.

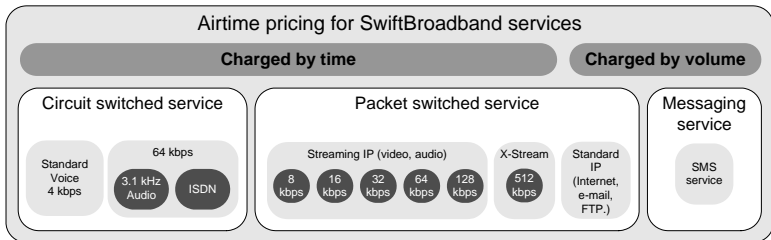

For information on service availability see *AVIATOR 700 Services* on page 4.

Background information, Classic Aero and Swift64 services

The Classic Aero services have a lower tariff than the Swift64 services, which are high quality audio or high speed data services and thus require more bandwidth.

Classic Aero services

The Classic Aero (H⁺) service supports near terrestrial-quality **Voice** at 4.8 kbps, over 2 different physical channels in both global- and spot beam. This means that the user can have 2 voice connections up at all times. This can be 2 incoming, 2 outgoing or 1 incoming and 1 outgoing connection. This service is less expensive than an ISDN connection, with only a small cost in voice-quality.

Besides using the two voice-channels for voice, one or both of the channels can be used for a **modem** or **fax** connection. In both circumstances, the

maximum bit rate is 2.4 kbps. The fax or modem can be connected to the 2-wire interface. If a fax or modem uses a channel, this channel cannot be used for voice at the same time.

Classic Aero also provides a low speed **packet data** mode, which allows data transfers at up to 1.2 kbps. This service can be used by an AFIS (Automatic Flight Information Service), ACARS (Aircraft Communication Addressing & Reporting System) or CMU (Communications Management Unit) to send data over the satellite link. Note, however, that this service must not be used as the basis for safety communication.

Swift64 data service

The **64 kbps UDI** (Unrestricted Digital Information) service enables bi-directional transmission of data to and from terrestrial 64 kbps **ISDN** networks. The **56 kbps Data** service is similarly used to make a connection to 56 kbps ISDN networks, which are primarily used in North America.

The **Speech** and **3.1 kHz audio** services make it possible to establish high quality analogue connections with quality equal to terrestrial analogue connections via digital networks/switches. The **Speech** service is used for high quality voice connections, whereas **3.1 kHz audio** can be used to transfer analogue signals between fax machines and modems with an analogue 2-wire interface. The 3.1 kHz audio service is transparent, and is suitable for all analogue applications including secure telephones.

The **MPDS service** is a packet data service where the tariff depends on the amount of data transmitted. This service is a more cost-effective solution for web browsing, and other applications where there is no need for constant transmission of data in both directions. It is also suitable for applications where a constant connection is required, because the user is no longer charged the “per minute rate”.

Get started

In this chapter

In this chapter you can read about:

- *Logon procedure*
- *Connect a computer*
- *Make the first call*
- *Send a fax*

For information on how to install, configure and service the system, see the AVIATOR 700 Installation and maintenance manual. For more detailed guidelines on the individual applications see *Calls, faxes and SMS* on page 33.

Line of sight

To use the satellite network, the satcom antenna must have free line of sight to the satellite.



Picture: airphotocino

Note

The system cannot logon to the satellite network and go online when the aircraft is inside a hangar.

Airtime service provisioning

To be able to establish a data connection or make a call the satcom system must be activated or commissioned by a service provider. This is taken care of during installation and configuration of the satcom system. The service provider provides the telephony and data services and invoices you for the services used. For information on service providers go to Inmarsat's web site, Partner search (<http://www.inmarsat.com/partners/search-for-partner/>). The service provider also handles activation, commissioning, billing and technical support that is related to the communication network.



The satcom system is operational and ready to use when the aircraft is powered up and the aircraft's navigational system has finished its initialization. Check whether your aircraft is equipped with a signal saying that the satcom system is ready for use before you start your application.

Default settings

The telephone and ISDN lines are available as soon as the system has logged on to the satellite network. Check whether your aircraft is equipped with a signal saying that the satcom system is ready for use.

Internet, e-mail and other IP services are available as plug-and-play, no further configuration is needed. The system automatically starts the standard background data connection when a PC, Smart Phone or other device is connected.

Important

With the plug-and-play functionality a computer automatically establishes a connection to the Internet and starts transferring data as soon as you start using the Internet, e-mail or other IP services.

To avoid unintended use of bandwidth, e.g. automatic software updates, see *Unintended use of bandwidth* on page 107 for information how to set up your computer.

Logon procedure

You can logon to satcom services using one of the following procedures:

- *Logon procedure with the Full Feature handset*
- *Logon procedure with the MCDU*

Logon procedure with the Full Feature handset

After power up the display and all LEDs on the Full Feature handset will light up for a few seconds, the SDU boots and makes a self test. The system is typically configured to log on automatically to the satellite services, no further action is required. When the display shows **Ready** all services are logged on and you can start using the system.

Ready		
AMER	AM	#x

In most cases the system logs to an I4 satellite. If there is no I4 coverage, the system logs on to an I3 satellite. Then the SwiftBroadband services are not available. The display will show: H⁺ (Classic Aero) and Swift64 are logged on (ok) and SBB (SwiftBroadband) is not available (0/1). Then you can make calls using the Full Feature handset and the SDU using the service H⁺ (Classic Aero) and you can use SW64 data.

H+	SBB	SW64
ok	0/1	ok

Note

If the system does not log on automatically, the system may be set to **manual logon**. In this case you have to log on using the Logon menu. For further information, see *To log on manually* on page 125.

LEDs on Full Feature handset

The Classic Aero LED and the Swift64 LED indicate that these services are logged on. This handset has no LED to indicate that the SwiftBroadband service is logged on. The SwiftBroadband service is logged on when the display shows Ready and the Swift64 LED is not lit.

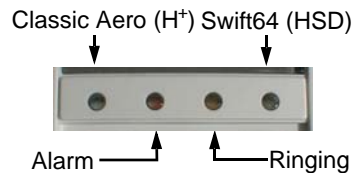

Logon procedure with the MCDU

After power up the system is typically configured to log on automatically to the satellite services. No further action is required to start up the AVIATOR 700 system. You can follow the logon procedure by selecting the **SATCOM** subsystem from the MCDU menu when the **SATCOM** subsystem becomes available. Below is an example of a display read-out while the SDU is booting. The screen shows the progress of the Power On Self Test (left) and the screen after a successful logon procedure (right).



For further information on logon settings, see *LOGON menu* on page 153.

Note

If the system does not log on automatically, the system may be set to **manual logon**. In this case you have to log on using the Logon menu. For further information, see *LOGON menu* on page 153.

Connect a computer

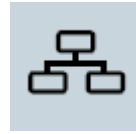

PC setup — before you start

For the LAN or WLAN interface to work without any further setup, the connected computer or IP device must be set up to obtain an IP address and a DNS server address automatically. This is usually the case for most PCs. If you are in doubt you can check your PC, see the step-by-step procedure how to do this in *IP address and DNS server address setup* on page 166.

Important

To avoid unintended use of bandwidth, e.g. automatic software updates, see *Unintended use of bandwidth* on page 107 for information how to set up your computer. It is recommended to **disable** the feature for **automatic PC software update** in your computer.

Internet, e-mail, etc.

With SwiftBroadband the cabin applications e-mail, Internet and intranet access, VPN, etc. are available. The connection type recommended for these applications is the Standard data connection, which is also the default setting. For background information on the Standard data connection see *Packet switched service* on page 20.

Depending on how your system was set up initially there are two scenarios that may be applicable when you use a data connection to access the Internet, e-mail etc.:

Standard data connection	Benefits	Drawback
Automatic start (system default)	Plug-and-play	Risk of unintended use of costly airtime, e.g. Windows update downloads, frequent check for new mail etc.

Standard data connection	Benefits	Drawback
Manual start from the web interface (This must be configured during initial configuration.)	Efficient bandwidth usage	You must start the web interface at http://192.168.0.1 and click once to start a connection.

Check with your system responsible whether your system is set up to automatic activation of a standard data connection (plug-and-play).

To access the Internet or use your e-mail program do as follows:

1. Switch on your PC or Smart Phone.
2. **For LAN:** Connect your LAN cable (standard Ethernet) between the network connector on your computer and one of the LAN connectors installed in the aircraft.
For WLAN: Check that the WLAN icon in the status bar of your operating system indicates that the WLAN connection has been established.

3. Start your application, e.g. Internet browser or e-mail program.
If you cannot establish a connection, the automatic activation of a standard data connection may be disabled in your system. Then you can start a connection manually, you do this in the built-in web interface. To learn more about the web interface see *Use the SBU web interface* on page 164.

How to establish a connection manually see *Start or stop a Standard connection* on page 110 or *Start or stop a Streaming connection* on page 111 for detailed instructions.

If you want to change the start-up mode of the standard data connection contact your system administrator to change the setting in your network user group for **Automatic activation** to **Enabled** or **Disabled**. This is described in detail in the AVIATOR 700 Installation and maintenance manual.

Make the first call



The following sections provide a short guide to making calls. For more detailed information, see *How to make calls from the Full Feature handset* on page 71 or *How to make calls from the Auxiliary Handset* on page 76.

If you want to use a SIP-enabled IP handset to make a call see *Use a SIP-enabled IP handset (SBU)* on page 81.

Make a call (air to ground)

To make a call from a phone or handset, press:

00 <country code> <phone number> followed by # or off-hook key.

Example: To call Cobham SATCOM VA that has the country code 1 and the phone number 7574639557 press
00 1 7574639557 #

Call a handset in the aircraft (ground to air)

Mobile numbers for SwiftBroadband

You find the voice numbers in the documentation in the aircraft cabin or from your service provider. They may also figure on the quick guide. Make sure you have the international dialling code for the country you want to call from.

To make a call to a phone connected to the SBU (ground to air), dial:

+ <Mobile number>

- **+** is the prefix used in front of the country code for international calls. The Prefix depends on from which country you make the call. It is 011 if you call from the USA.
- **Mobile number for handsets connected to the SBU:** This is the mobile number of the system you are calling. The first part of the number is always 870, which is the “country code” for the BGAN system.

Note

There are two Voice numbers, one for 3.1 kHz Audio and one for Standard Voice.

Example: If you are calling from the USA and the mobile number for standard voice is 870772420567 on your system, and you want to make a call to the system, dial **011 870 772420567**.

Note

For fax installations: If you have connected a fax, make sure that the incoming call type on that 2-wire interface is set to 3.1 kHz Audio. This is to avoid that the fax rings and answers an incoming Standard call. This is usually taken care of during initial configuration of the system. See the AVIATOR 700 installation and maintenance manual for further information on connecting a fax to the SBU.

Voice mail for SwiftBroadband

If a call to a handset marked AVIATOR 700 is not answered the caller can leave a voice mail message with Inmarsat's voice mail service. Then an SMS is sent to the messaging system of the SBU to alert you that there is a voice mail message. For further details see *To receive a voice mail message (SBU)* on page 52.

Mobile number for Classic Aero services

To make a call to a phone connected to the system do as follows:

Dial + **<Mobile number>**

To make a phone call to a handset in the aircraft you can proceed in two ways:

Classic Aero	Details	Dialling example
Direct phone number	A direct phone number to call a handset in the aircraft directly. When using this number a dialling prefix is not required. Check the documentation from your service provider whether this service is supported.	See the documentation from your service provider.
Numbering rules for AESID	<p>The international prefix used to call from the ground is +870</p> <p>+ is the prefix used in front of the country code for international calls. The Prefix depends on from which country you make the call. It is 011 if you call from the USA.</p> <p>Note: In some countries or networks the access to +870 maybe restricted and requires an account to be set with the local service provider.</p> <p>Dial: +870 5 <AESID></p>	<p>If you are calling from the USA and the ICAO address is 01234567 dial: 011 870 5 01234567</p>

To call using DDI numbers see *To call ground to air using the DDI numbers* on page 38, for more information about SWIFT64 number see *Swift64 numbering rules* on page 39.

Send a fax

Important

Before sending or receiving fax messages, make sure both fax units are in “Overseas” mode.



Send a fax via SBU

To send a fax from the terminal (SBU), use the prefix **00**, followed by the called fax number including the country code, followed by **#**.

Example: To send a fax to Cobham SATCOM VA (country code 1) over SwiftBroadband, press the following keys on the fax:
00 1 757 463 9557 #

Send a fax via SDU

To send a fax from the terminal (SDU), use the prefix **01** for fax, followed by the called fax number including the country code, followed by **#**.

Example: To send a fax to Cobham SATCOM VA (country code 1) over Classic Aero press the following keys on the fax:
01 1 757 463 9557 #

You can also send a fax over Swift64, for instructions see *To send a fax message (air to ground) (SDU)* on page 44.

To power off the satcom system

The satcom system is automatically powered off along with the aircraft. Some types of aircraft are equipped with a “SatCom on/off” button, which can be used to power off the satcom system while the aircraft is powered.

Calls, faxes and SMS

Introduction

The AVIATOR 700 system has two PBXs. Study the following chapters thoroughly, because you need to know to which units — SDU or SBU — the phone or fax is connected, to be able to call or use the fax successfully. For some functions you also have to know whether you use the Full Feature handset or a POTS (2-wire) handset like the Auxiliary handset. The following illustration shows schematically which phone and fax connections are available.

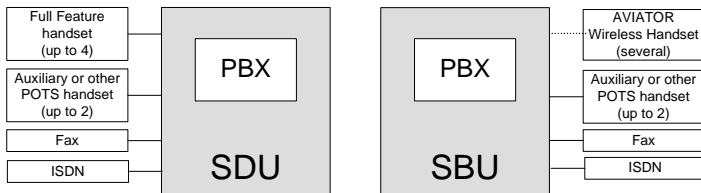

In this chapter

In this chapter you can read about:

- Use a phone or fax machine (SDU)
- Use a phone or fax machine (SBU)
- Operate the handsets
- Use the MCDU
- SMS service

Use a phone or fax machine (SDU)



Available interfaces (SDU)

Several types of voice equipment connect to the SDU:

Standard analog phone or G3 fax machine: The SDU has two phone interfaces for connecting standard analog phones or fax machines.

ISDN phone or G4 fax machine: The SDU has one ISDN interface for connecting an ISDN phone, a modem or a fax machine.

Full-feature handset: the SDU has four phone interfaces for connecting Full Feature handsets.

Check the cabin installation to locate the SDU connectors for telephones and fax machine.

Select a call type (SDU)

This is typically set up during initial configuration of the system.

The phone connection can use one of the following call types:

- **H⁺ Voice:** Voice connection compressed to 4.8 kbps,
- **3.1 kHz Audio:** High quality connection used for Premium Voice, G.3 fax or analog modem,
- **UDI or RDI** (only on ISDN interface): used for G4 fax or data

The default setting for an AVIATOR 700 system is standard voice.

In the Aero-SDU Configuration Program which is used during the installation of the system you can set up which type of connection should be preferred to use when you make or receive a call from the telephone interfaces.

Note

Modem or fax: When connecting a fax or a modem to the Phone/Fax interface you must use 3.1 kHz Audio.

Example: If you always have a fax connected to the same Phone/Fax interface you can set this interface to 3.1 kHz Audio only. This will mean that if an incoming Standard Voice call is received, this Phone/Fax interface will not ring. For details how to set up the interfaces see the AVIATOR 700 Installation and maintenance manual.

When connecting a G4 fax or a modem to the ISDN interface in the AVIATOR 700 system you must use UDI.

To select the default outgoing call type (SDU)

This is typically set up during initial configuration of the system.

You can set the default outgoing call type in the Aero-SDU Configuration Program. For further information, see the AVIATOR 700 Installation and maintenance manual and the online help of the Aero-SDU Configuration Program.

Important

Primary and secondary call types can be configured in the Aero-SDU Configuration Program. If all channels for the primary call type are in use, the secondary call type will be used.

To override the default outgoing call type (SDU)

To override the default setting for a specific outgoing call, dial the following prefix before the number you want to call or fax:

- 00: Use default call type
- 01: Use default fax type
- 10: Force the call type to H+ (Classic Aero) (Standard voice)
- 11: Force fax type H+ (Classic Aero)
- 20: Force call type HSD (Swift64) (High-quality voice)
- 21: Force fax type HSD (Swift64)

Example: To call Cobham SATCOM VA, that has the country code 1 and the phone number 7574639557, forcing the connection to use Standard Voice, dial **10 1 7574639557** followed by # if calling from an analog or ISDN phone, or off-hook key if calling from an AVIATOR Wireless Handset.

Note | This will not change the default call type, only the type used for this call.

Phone numbers for incoming 3.1 kHz Audio and Standard Voice

The phone numbers are listed in the documentation from your service provider.

Note | The call type you are using must be selected in the Aero-SDU Configuration Program.

For information on how to make a call to the system, see *Phone number for a call (ground to air) (SDU)* on page 38.

To select the incoming call type (SDU)

This is set up during initial configuration of the system. For further information, see the AVIATOR 700 Installation and maintenance manual and the online help of the Aero-SDU Configuration Program.

Make or receive a phone call (SDU)



Analog phone, ISDN phone or Full Feature handset

There are different methods for activating a call, depending on the type of phone:

- **Analog phone or ISDN phone:** Dial the number and press #.
- **Full feature handset:** Dial the number and press the off-hook key.

To make a call (air to ground) (SDU)

You have the following options for making a call:

- **Manual Dial.** Dial **00 <country code> <phone number>** followed by # or off-hook key.

Example: To call Cobham SATCOM VA that has the country code 1 and the phone number 7574639557 press **00 1 7574639557** followed by # if calling from an analog or ISDN phone.

- **Full Feature handset: Call a number in the SDU phone book.** If the number you want to call is in the phone book of the SDU, find the number in the phone book and press # or off-hook key.

Example: To call entry in the SDU phone book with the name Jones, press **OK OK** to enter the phone book, then **[5.jk]**. To find an entry with the name Larsen, press **[5.jk]** three times. For more detailed information about the SDU phone book see *Use the SDU phone book* on page 115.

If there was an error establishing the connection, refer to *SDU errors* on page 190.

To receive a call (SDU)

By default, all devices connected to the 4-Wire interfaces, 2-Wire interface and the ISDN interface will ring when one of the mobile numbers is called. Note, however, that this depends on the call type settings made during initial configuration of the system. For further information, see the

AVIATOR 700 Installation and maintenance manual and the online help of the Aero-SDU Configuration Program.

Phone number for a call (ground to air) (SDU)

For details on how to make a call to a phone connected to the system see *Mobile number for Classic Aero services* on page 31.

To call ground to air using the DDI numbers

It is possible to dial a specific terminal in the aircraft, using a specific service (voice, fax or data).

From a ground phone dial: **+870 5 <DDI> <Terminal Number>**

DDI (Direct Dial-In)

The DDI number identifies both the terminal on the network and the service used (Voice, Fax or Data).

Note

In the Service Activation Registration Form (SARF), the allocation of DDI number is optional. Make sure that they are requested when submitting the SARF.

Example: The following is an example of a Ground to air call using DDI numbers:

If the DDI numbers allocated are:

-111112 for voice

-111113 for fax

-111114 for data

-and you are making a call from USA,

the phone number to dial on the ground to call handset #2 is:

011 870 5 111112 02 (011 for prefix to dial out of the USA - 870 international prefix to call from the ground - 5 for H⁺ service - DDI Voice - Terminal number 2)

Under the same circumstances, the phone number to dial on the ground to send a fax connected to POTS #5 is:

011 870 5 111113 05 (011 for prefix to dial out of the USA - 870 international prefix to call from the ground - 5 for H⁺ service - DDI Fax - Terminal number 5)

Local numbers

- 00: The terminal will behave as if it has received a call using the AES ID (a broadcast call to all handsets)
- 01: Handset #1 (Full Feature handset)
- 02: Handset #2 (Full Feature handset)
- 03: Handset #3 (Full Feature handset)
- 04: Handset #4 (Full Feature handset)
- 05: POTS #5 (2-wire analog phone)
- 06: POTS #6 (2-wire analog phone)

Swift64 numbering rules

IMN (Inmarsat Mobile Number): To make a ground-to-air call to a terminal using swift64, the caller can use the IMN numbers as follows:

Dial **+870 <IMN number>**

An IMN is the network identification for a specific service on a specified terminal. The service can be ISDN DATA64, ISDN DATA56, SPEECH or AUDIO3.1.

Example: If the IMN number is 612345678 and you are making the call from USA, dial **011 870 612345678**.

To make local phone calls (SDU)

You can make local phone calls between any of the POTS phones and 4-wire handset interfaces of the SDU.

Important

This feature works with handsets connected to the SDU. Check whether the handset is marked "SDU".

Note

The local number is shown in the lower right corner of the display of the Full Feature handsets.

To make a local call to a phone connected to the SDU do as follows:

Dial **<local number>** and press # or the off-hook key.

Special-purpose and local numbers

The following list shows the allocated special-purpose numbers.

Local number	Phones
 0	Broadcast call to all phones connected to the SDU
1	4-Wire (Full Feature handset) #1
2	4-Wire (Full Feature handset) #2
3	4-Wire (Full Feature handset) #3
4	4-Wire (Full Feature handset) #4
5	2-Wire handset (Auxiliary or similar) #5
6	2-Wire handset (Auxiliary or similar) #6
10	ISDN

To hold a call (SDU)

You can put an incoming, outgoing or local call on hold once the connection is established. To place an active call on hold, press the hold button on the phone. Once the call is put on hold, a ready tone will sound in the handset. To reactivate the call, press the hold button a second time.

Note Which key works as a **hold button** varies from phone to phone. To find out which button is the hold button on your handset, refer to the phone's user manual. On some digital phones, an **R** button functions as the hold button (like for the Auxiliary Handset). On analog phones without a dedicated hold button, a short press on the hook button functions as a hold button (this is called the flash button on analog phones).

To place a call on hold using the **Auxiliary handset**, do as follows:

1. Press **R**.
2. To reactivate the call, press **R**.

To place a call on hold with the **Full Feature handset**, do as follows:

1. Press **2nd 0**.
2. To reactivate the call, press **2nd 0**.

Note Only one call can be placed on hold at the same time by a single phone.

To transfer a call (SDU)

An incoming or outgoing call can be transferred from one local phone A to another local phone B connected to the same SDU.

Use the following procedure to make a call transfer using the **Auxiliary handset**:

1. Press **R** on phone A to put the call on hold.
2. On phone A, dial the desired handset, e.g. **2_{abc}** for handset #2. For local numbers see *Special-purpose and local numbers* on page 40.

3. Establish a connection between phone A and B with **#**.
4. The transfer can then be initiated by either phone:
 - Hang up phone A or
 - Press ***** **2** **2** **2** from phone B.

Note To transfer a call from a POTS phone, the procedure is the same as for the Auxiliary Handset except from the method to put the call on hold. For information how to put a call on hold from a POTS phone see *To hold a call (SDU)* on page 41.

Use the following procedure to make a call transfer using the **Full Feature handset**:

1. When a call is already established, place the call on hold with **2nd** **0**.
2. On phone A dial the number of the desired handset, e.g. **2** for Handset #2. For local numbers see *Special-purpose and local numbers* on page 40.
3. Establish a connection between phone A and B with **#** or **Join**.
4. The transfer can then be initiated by either phone:
 - Hang up phone A or
 - Press **2nd** **Route** from either handset A or B

To make a conference call (SDU)

It is possible to make conference calls between three or more parties.

Conference call (SDU)

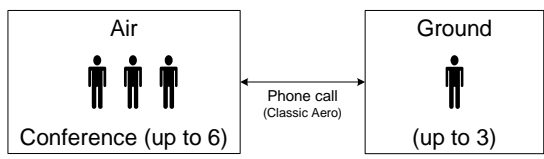

Note Max. 6 lines can be connected, including handsets on the aircraft and lines to the ground.

When a call is already established, do as follows to add additional parties with an **Auxiliary Handset**:

1. Press **R** to put the call on hold.
2. On phone A, dial the desired handset, e.g. **2_{abc}** for handset #2, or an external number. For local numbers see *Special-purpose and local numbers* on page 40.
3. Establish connection with **#**.
4. Join all three calls by pressing ***** **3_{def}** **3_{def}** **3_{def}** from either phone.
5. To add further parties to the conference all, repeat steps 1 to 5.
6. To leave a conference, press **⏪** or put handset back into the cradle.

Note

To make conference call from a POTS phone, the procedure is the same as for the Auxiliary Handset except from the method to put the call on hold. See *To hold a call (SDU)* on page 41 for information about putting calls on hold from a POTS phone.

When a call is already established, do as follows to add additional parties with the **Full Feature Handset**:

1. Place the call on hold with **2_{nd}** **0^{hold}**.
2. Dial the number of the desired handset, e.g. **2_{abc}** for Handset #2, or an external number. For local numbers see *Special-purpose and local numbers* on page 40.
3. Establish a connection between phone A and B with **#^{bin}** or **⏪**.
4. Join all three calls by pressing **2_{nd}** **#^{bin}** from either handset.
5. To add further parties to the conference call, repeat steps 1 to 5.
6. To leave a conference, press **⏪** or put handset back into the cradle.

Note

When the last local phone exits the conference call, the conference call is terminated though there may still be two or three incoming/outgoing callers active.

Send or receive a fax message (SDU)



Delay before time-out

When sending or receiving fax messages over a satellite connection, the fax units at each end of the transmission line must be capable of handling longer delays without timing out. Some fax machines have an Overseas mode, which enables the unit to handle the long delays. Make sure that your fax machine is set to allow long delays before time-out.

To send a fax message (air to ground) (SDU)

Important | Before sending or receiving fax messages, make sure both fax units are in “Overseas” mode.

The fax machine must be connected to the Phone/Fax interface or the ISDN interface of the SDU. For an analog fax machine **3.1 kHz Audio** should be used. For an ISDN G4 fax machine **UDI** must be used, refer to the AVIATOR 700 Installation and maintenance manual for details how to configure the ISDN interface.

To send a fax from the SDU, use the prefix **01** for fax, followed by the called fax number including the country code, followed by **#**. For more information how to override call types see *To override the default outgoing call type (SDU)* on page 36.

Example: To send a fax to Cobham SATCOM VA (country code 1) over Classic Aero press the following keys on the fax:
01 1 757 463 9557 #

To send a fax message (ground to air) (SDU)

Important | Before sending or receiving fax messages, make sure both fax units are in “Overseas” mode.

To send a fax message to the SDU, dial: + **<Mobile number> #**

- + is the prefix used in front of the country code for international calls.

- **Mobile number.** The first part of the mobile number is always 870, which is the “country code” for the Inmarsat system. The numbers are listed in the documentation from your service provider.

To receive a fax message (SDU)

A fax machine connected to the SDU can receive a fax in two ways:

- Using Classic Aero: 2.4 kbps modem/fax
- Using Swift64: 3.1 kHz Audio or G4 fax ISDN/UDI.

For further information see *To select the incoming call type (SDU)* on page 36.

Use a phone or fax machine (SBU)



Available interfaces (SBU)

Several types of voice equipment connect to the SBU:

Standard analog phone or G3 fax machine: The SBU has two phone interfaces for connecting standard analog phones or fax machines.

ISDN phone or G4 fax machine: The system has one ISDN interface for connecting an ISDN phone, a modem or a fax machine.

SIP-enabled IP phone: the SBU has an integrated SIP server for connecting a SIP-enabled IP phone. For more details on setting-up and using a SIP-enabled IP phone see *To set up a SIP-enabled wireless IP handset (SBU)* on page 81.

Check the cabin installation to locate the SBU connectors for telephones and fax machine.

Select a call type (SBU)

This is typically set up during initial configuration of the system.

The phone connection can use one of the following call types:

- **Standard Voice:** Voice connection compressed to 4.0 kbps,
- **3.1 kHz Audio:** High quality connection used for Premium Voice, G.3 fax or analog modem,
- **UDI or RDI** (only on ISDN interface): used for G4 fax or data

The default setting for an AVIATOR 700 system is standard voice.

In the web interface you can set up which type of connection to use when you make or receive a call from the Phone/Fax or ISDN interface or from an IP handset connected to the LAN interface.

Note

Modem or fax: When connecting a fax or a modem to the Phone/Fax interface you must use 3.1 kHz Audio.

Example: If a fax is always connected to the same Phone/Fax interface you can set this interface to 3.1 kHz Audio only. This means that if an incoming Standard Voice call is received, this interface will not ring. For details how to set up the interfaces see the AVIATOR 700 Installation and maintenance manual.

When connecting a G4 fax or a modem to the ISDN interface in the AVIATOR 700 system you must use UDI.

To select the default outgoing call type (SBU)

This is typically set up during initial configuration of the system.

You can set the default outgoing call type in the web interface. For details how to access the web interface see *Access the web interface* on page 167. To select the default call type for outgoing calls, do as follows:

- **ISDN:** Select the call type under **SETTINGS > ISDN**.
- **Phone/Fax:** Select the call type for each port under **SETTINGS > Phone/Fax**.
- **AVIATOR Wireless Handset:** Select the call type for each handset under **SETTINGS > IP handsets > Call settings**.

For further information, see the AVIATOR 700 Installation and maintenance manual.

To override the default outgoing call type (SBU)

To override the default setting for a specific outgoing call, do as follows:

- To use **Standard Voice** for the call, dial **1*** before the number.
- To use **3.1 kHz Audio** for the call, dial **2*** before the number.

Example: To call Cobham SATCOM VA that has the country code 1 and the phone number 7574639557, forcing the connection to use Standard Voice, press **1* 00 1 7574639557** followed by # if calling from an analog or ISDN phone, or off-hook key if calling from an IP handset.

Note

This will not change the default call type, only the type used for this call.

Phone numbers for incoming 3.1 kHz Audio and Standard Voice (SBU)

The two CS connections 3.1 kHz Audio and Standard Voice have separate phone numbers. This way, a person calling a phone connected to the system can select whether to use 3.1 kHz Audio or Standard Voice, simply by using the dedicated mobile phone number. The phone numbers are listed in the documentation from your service provider.

Note | The call type you are using must be selected in the web interface (refer to the next section).

If the mobile phone numbers have been entered in the web interface they are listed and you can look them up as follows:

1. Access the web interface from a connected computer, open a browser and type the address: **http://192.168.0.1** (default address). The **DASHBOARD** page is displayed.
2. Select **PHONE BOOK > Mobile numbers**.

Note | There are two Voice numbers, one for 3.1 kHz Audio and one for Standard voice.

For further information, see *To view the mobile numbers and additional numbers* on page 175. If the mobile numbers are not available in the web interface, refer to the documentation from your airtime subscription.

For information on how to make a call to the system, see *To make a call (ground to air) (SBU)* on page 51.

To select the incoming call type (SBU)

This is typically set-up during initial configuration of the system.

To select which call types are accepted for an incoming call do as follows:

1. Access the web interface from a connected computer by opening a browser and typing the address: **http://192.168.0.1**. The **DASHBOARD** page is displayed.
2. **ISDN**: Select the call type under **SETTINGS > ISDN**.
3. **Phone/Fax**: Select the call type for each port under **SETTINGS > Phone/Fax**.
4. **AVIATOR Wireless Handset**: Select the call type for each handset under **SETTINGS > IP handsets > Call settings**.

For further information, see the AVIATOR 700 Installation and maintenance manual.

Make or receive a phone call (SBU)

Analog phone, ISDN phone or SIP-enabled IP handset



There are different methods for activating a call, depending on the type of phone:

- **Analog phone or ISDN phone**: Dial the number and press #.
- **SIP-enabled IP handset**: Dial the number and press the off-hook key.

To make a call (air to ground) (SBU)

You have different options for making a call:

- **Short Dial**. If the number you want to call is in the phone book of the system, you can use the Short Dial number. You find this number in the web interface under **PHONE BOOK**, first column **Entry**.

Dial **00 <Short Dial>** followed by **#** or off-hook key.

Example: To call entry number 4 in the phone book, dial **004** followed by **#** or off-hook key.

Note

Maximum 4 digits are allowed. If the number is higher than 0099, only one zero should be added (example: 0199)

- **Manual Dial.** Dial **00 <country code> <phone number>** followed by **#** or off-hook key.

Example: To call Cobham SATCOM VA that has the country code 1 and the phone number 7574639557 press **00 1 7574639557** followed by **#** or off-hook key.

- **Call from phone book or call log** (only AVIATOR Wireless Handset).
 - Enter the phone book of the IP handset, scroll to the wanted number and press the off-hook key, or
 - press the off-hook key from the main screen to display the latest calls in the call log. Then scroll to the wanted number and press the off-hook key again.
Note that this is the call log of the IP handset, not of the system.

If there was an error establishing the connection, refer to *SBU errors* on page 198.

If you are using the IP handset, the handset may show an error message. Depending on the type of error, the web interface may also show an error message. See *Event log and self test* on page 199.

To receive a call (SBU)

By default, all devices connected to the analog phone interface and the ISDN interface and the WLAN interface will ring when one of the mobile numbers is called. Note, however, that this depends on the call type settings for ISDN, AVIATOR Wireless Handset and analog phone made during initial configuration of the system. For further details on how to set up the individual interfaces see the AVIATOR 700 Installation and maintenance manual and the documentation for your cabin installation. You can see the current setting of the SBU interfaces in the web interface.

Call log (SBU)

You can recall information of all incoming, outgoing and missed calls, as well as standard and streaming data sessions. This data is stored in the call log of the system. To view information on all calls do as follows:

1. Access the web interface from a connected computer, open a browser and type the address: **http://192.168.0.1** (default). The **DASHBOARD** page is displayed.
2. Click **CALLS**. For further information, see *View the lists of calls* on page 177.

If power to the system is interrupted, the information on the currently ongoing calls (connection time) and data sessions (transferred data) cannot be saved. This means that the airtime and bandwidth usage registered in the Call log may be slightly inaccurate.

To make a call (ground to air) (SBU)

To make a call to a phone connected to the system do as follows:

Dial + <**Mobile number**>

+ is the prefix used in front of the country code for international calls.

Mobile number: The first part of the mobile number is always 870, which is the prefix (“country code”) for the BGAN system.

Example: If you are calling from the USA and the mobile number for standard voice is 870772420567 on your system, and you want to make a call to the system, dial **011 870 772420567**.

The phone numbers are listed in the documentation from your service provider. If the mobile numbers are listed in the web interface, you can look them up as follows:

1. Access the web interface from a connected computer, open a browser and type the address: **http://192.168.0.1** (default). The **DASHBOARD** page is displayed.
2. Select **PHONE BOOK > Mobile numbers**. For further information, see *To view the mobile numbers and additional numbers* on page 175.

If the mobile numbers are not available in the web interface, see the documentation from your service provider.

Note

There are two Voice numbers, one for 3.1 kHz Audio and one for Standard Voice.

To receive a voice mail message (SBU)

If a call to the AVIATOR 700 system is not answered the caller can leave a voice mail message with Inmarsat's voice mail service. Then an SMS is sent to the AVIATOR 700 messaging system to alert you that there is a voice message with the contents:

- Number called from
- Date and time the voice mail message has been received
- Number to call to listen to the voice mail message.

To see that a new SMS has arrived you open the web interface. For further details see *SMS service* on page 94 and *View the Voice mail number* on page 178.

On first-time use the voice mail box at Inmarsat's voice mail service must be configured, follow the instructions given when you call the number to listen to a voice mail message.

To make local phone calls (SBU)

You can make local calls between various phones connected to the SBU. Local phone numbers always start with 0. For an overview of the numbers, see *Special-purpose and local numbers* on page 40.

Important

This feature works with handsets connected to the SBU. Check whether the handset is marked "SBU".

To make a local call dial **<local number>** followed by **#** or off-hook key.

Local numbers of analog phones, ISDN phones and IP handsets are assigned according to the table in *Special-purpose and local numbers* on page 40. Note that if you are using local numbers for ISDN and SIP enabled IP devices, the numbers must be programmed in the devices. For further information refer to the documentation for your device.

Special-purpose and local numbers (SBU)

The following list shows the allocated special-purpose numbers.

Number	Function
0 * followed by # or off-hook key	Re-dial last called number on this interface.
00 * followed by # or off-hook key	Re-dial last answered call on this interface. Note: If the last answered number is an unlisted number, you will not be allowed to dial back.
00 followed by one of the numbers 1-99 and # or off-hook key 0 followed by one of the numbers 100-199 and # or off-hook key	Short dial phone numbers in phone book.
0300 followed by # or off-hook key	Local call broadcast to both analog phones.
0 followed by one of the numbers 301-302 and # or off-hook key	Local call to analog phone.
0400 followed by # or off-hook key	Local call broadcast to all ISDN phones. ^a
0 followed by one of the numbers 401-402 and # or off-hook key	Local call to ISDN phone. ^a
0500 followed by # or off-hook key	Local call broadcast to all IP handsets. ^a
0 followed by one of the numbers 501-516 and # or off-hook key	Local call to SIP-enabled IP handset. ^a
0900 followed by # or off-hook key	Local call broadcast to all handsets.

- a. Note that the local number must be programmed in the ISDN and SIP-enabled IP phone.

Dialing prefixes (SBU)

Apart from the numbers above, you can use the following dialing prefixes before the number:

Prefix	Function
1*	Forces the connection to use Standard Voice .
2*	Forces the connection to use 3.1 kHz Audio .
#31#	Hides the caller's phone number to the recipient.
*31#	Shows the caller's phone number to the recipient where it would otherwise be hidden, e.g. because the number is an ex-directory number.
R	The following key-presses should activate a supplementary services function supported by the system. These function are described in the following sections.

Note

Which key works as a **button** to activate supplementary services varies from phone to phone. To find out which button activates supplementary services on your handset, refer to the phone's user manual. On some digital phones, an **R** button functions as this button (like for the Auxiliary Handset). On analog phones without a dedicated hold button, a short press on the hook button triggers this function (this is called the flash button on analog phones).

To handle waiting calls (SBU)

Note | The phone must have an R key to be able to use these functions.

During a local or external call, if a second party attempts to make contact with you, you may hear a Call Waiting indication. This indication is two beeps and a pause of 3 seconds, then two beeps again etc. If no action is taken, the waiting call is released after a time-out period.

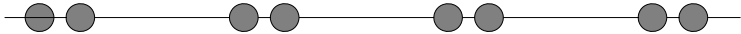

In the web interface you can enable or disable the call waiting indication. For further information how to set-up the call waiting function see the AVIATOR 700 Installation and maintenance manual.

When you receive a Call Waiting indication, you have the following options:

If you want to:	Do as follows:
Clear the current call, and accept the waiting call.	Press R 1 # , within the time-out period.
Hold the current call, and accept the waiting call.	Press R 2 # , within the time-out period.
Ignore the waiting call.	Take no action.
Reject the waiting call.	Press R 0 # , within the time-out period.

Note | The SwiftBroadband system only supports one circuit-switched call at a time per AVIATOR 700 system.

To hold a call (SBU)

Note | The phone must have an R key to be able to use these functions.

During a local or external call, you may place the initial call on hold while another call is made.

If you want to:	Do as follows:
Place a call on hold.	Press R 2 # .
Place the existing call on hold and establish a new call.	Press R and dial the second phone number followed by # .
Shuttle between the two calls.	Press R 2 # (irrespective of whether the second call was acquired using Call Hold or acceptance of Call Waiting.)
Clear the held call, if no waiting call exists.	Press R 0 # .
Clear an active call and return to the held call.	Press R 1 # . Note that this is only possible if no waiting call exists.

Note | The SwiftBroadband system only supports one circuit-switched call at a time per AVIATOR 700 system.

To transfer a call (SBU)

Note | The phone must have an R key to be able to use these functions.

When you receive a call, you can transfer this call to another phone connected to the system.

To transfer the incoming call to another phone or headset, do as follows:

1. Press **R 4 * <local number> #**.
The phone with the local number you dialed starts to ring.
2. You now have two options.
 - Hang up. The phone or headset you transferred the call to continues to ring. When the call is answered, a connection is established between the initial caller and the new recipient.
 - Do not hang up. When the new recipient answers, you can have a conversation before hanging up. When you hang up, the call is handed over to the initial caller.

Note | The SwiftBroadband system only supports one circuit-switched call at a time per AVIATOR 700 system.

To make a multi-party call (SBU)

Note | The phone must have an R key to be able to use these functions.

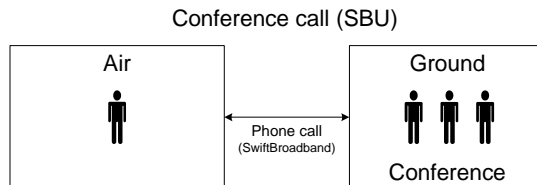

When you have an already established call you can initiate a conference call by using the following options:

If you want to:	Do as follows:
Add an incoming call announced by the Call Waiting indication.	Press R 2 # , the already established call is put on hold and the incoming call is connected for you to have an initial conversation with the caller before the call is added to the conference call. Then press R 3 # , you are returned to the held calls and the incoming call is joined in the conference call.
Initiate a new call and have it joined to the already existing call.	Press R <phone number> # , to initiate a new call and have an initial conversation before the call is added to the conference call. Then press R 3 # , you are returned to the held calls and the initiated call is joined in the conference call.
Clear all calls.	Press R 1 # or alternatively just hang-up.

To forward a call (SBU)

You can set up the system to automatically forward incoming calls to another phone number. This information is saved in the BGAN network so it is available when the call cannot be put through and must be forwarded. This service is usually set up by the airtime provider.

To forward incoming calls do as follows:

1. Access the web interface from a connected computer, open a browser and type the address: **http://192.168.0.1** (default). The **DASHBOARD** page is displayed.
2. Select **SETTINGS > Common > Call forward** from the left navigation pane.

Read current settings

STANDARD VOICE

Forward all calls Enabled

Forward when busy Enabled

Forward if not reachable Enabled

Forward if no reply Enabled when unanswered in

3.1 KHZ AUDIO

Forward all calls Enabled

Forward when busy Enabled

Forward if not reachable Enabled

Forward if no reply Enabled when unanswered in

DATA/ISDN

Forward all calls Enabled

Forward when busy Enabled

Forward if not reachable Enabled

Forward if no reply Enabled when unanswered in

- Click **OK** next to **Read current settings** to display the phone numbers for call forwarding for the subscription. These numbers are operator controlled and come with your airtime subscription (default). A message saying **Operation in progress, please wait.** is displayed.

Note

Allow sufficient time for the system to read the current settings over the satellite connection.

- For each call type, select **Enabled** next to the situation(s) in which you want to forward incoming calls.
- Next to the enabled items, type in the phone number to forward the call to.
- If you have selected **Forward if no reply**, select from the drop-down list the period of time to wait before forwarding the call.
- Click **Apply**.

Send or receive a fax message (SBU)



Delay before time-out

When sending or receiving fax messages over a satellite connection, the fax units at each end of the transmission line must be capable of handling longer delays without timing out. Some fax machines have an Overseas mode, which enables the unit to handle the long delays. Make sure that your fax machine is set to allow long delays before time-out.

To send a fax message (air to ground) (SBU)

Important

Before sending or receiving fax messages, make sure both fax units are in “Overseas” mode.

Note

In case the default setting in the web interface is not 3.1 kHz Audio, dial 2 * before the number, to force the connection to use 3.1 kHz Audio for fax use. For further information, see *To override the default outgoing call type (SDU)* on page 36.

The fax machine must be connected to the Phone/Fax interface or the ISDN interface of the system. See the AVIATOR 700 Installation and maintenance manual for further details.

3.1 kHz Audio must be used for an analog fax machine. See *To select the default outgoing call type (SDU)* on page 35.

UDI must be used for an ISDN G4 fax machine, refer to the AVIATOR 700 Installation and maintenance manual for details how to configure the ISDN interface.

To send a fax from a fax machine connected to the system, dial
00 <country code> <phone number> #

Example: To send a fax to Cobham SATCOM VA (+1 757 463 9581), dial
00 1 757 463 9581 #

To send a fax message (ground to air) (SBU)

Important

Before sending or receiving fax messages, make sure both fax units are in “Overseas” mode.

To send a fax message to the system, dial

+ <**Mobile number**> #

- + is the prefix used in front of the country code for international calls.
- **Mobile number.** The first part of the mobile number is always 870, which is the “country code” for the BGAN system.

To send a fax to a G3 fax use the 3.1 kHz Audio mobile number

To send a fax to an ISDN G4 fax use the UDI number.

The numbers are listed in the documentation from your service provider. If the mobile numbers are listed in the web interface, you can look them up as follows:

Connect a computer, access the web interface and select **PHONE BOOK > Mobile numbers**. For further information, see *To view the mobile numbers and additional numbers* on page 175.

Note

There are four mobile numbers, one for 3.1 kHz Audio, one for Standard voice, one for UDI and one for RDI.

To receive a fax message

An analog fax machine connected to the system can only receive a fax with 3.1 kHz Audio. Refer to *To select the incoming call type (SDU)* on page 36.

An ISDN G4 fax machine connected to the AVIATOR 700 system can only receive a fax with a call type UDI.

Operate the handsets

For information how to operate the AVIATOR Wireless Handset see the *AVIATOR Wireless Handset and Cradle, User Manual* (order number: 98-129599). The following handsets are described in detail:

- *Operate the Full Feature handset*
- *Operate the Auxiliary handset*
- *How to make a call with the Sigma⁷ handset*
- *How to make a call with the 2.4GHz Cordless handset*
- *How to make a call from an ISDN phone*
- *Use a SIP-enabled IP handset (SBU)*

Operate the Full Feature handset

The Full Feature handset is the primary interface for the AVIATOR 700 system. With the Full Feature handset you can dial numbers, view error and status messages, and configure the transceiver. This handset can only be connected to the SDU.

The Handset is divided into the following 4 inter-working sections.

- The Liquid Crystal Display (LCD) and Light Emitting Diodes (LED) section. This section gives you visual indications about the operation and status of the system.
- The Function keys section. This section enables you to interact with the software menu system of the transceiver.
- The Alpha-Numeric section. This section enables you to dial and to enter data into the transceiver.
- The volume control. A control placed on the side of the handset for easy adjustment of the volume.



Display and LEDs

The following picture shows the top of the handset with the display and LEDs. The LCD can be adjusted for contrast and is backlit for viewing in dim light or at night, see *To adjust the LCD contrast* on page 119 and *To change the light settings* on page 119.



The LCD display is graphically shown below:

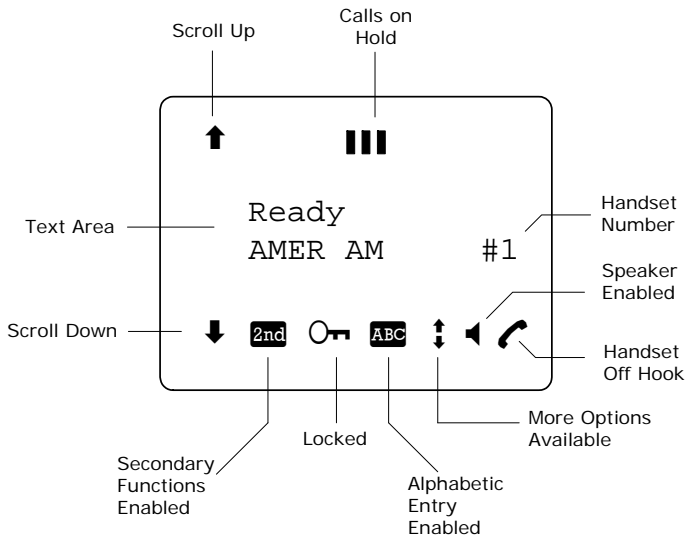

The display contains a set of symbols which, together with the 4 LEDs situated below the display, continuously indicate the current status.



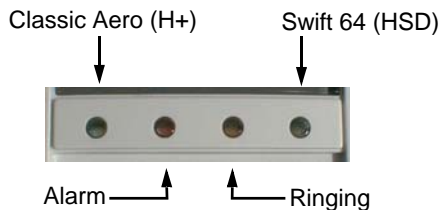







There are four LEDs below the LCD display.







- **Classic Aero (H⁺) LED (GREEN):** The H⁺ LED indicates that the system is logged on to H⁺ services.
- **Alarm LED (RED):** The Alarm LED illuminates when the system detects a fatal or essential fault. An error code is also shown in the display.
- **Ringing LED (AMBER):** The Ringing LED flashes when the handset is ringing. When a connection is established the LED is turned off.
- **Swift64 LED (GREEN):** The Swift64 LED indicates that the system is logged on to Swift64 services. Note that this LED is **not lit** when the system is logged on to an I4 satellite providing **SwiftBroadband services**.

Display symbols

The below list shows the meaning of each of the various symbols, that may appear in the display.

Symbol	Meaning
	More menu entries above.
	Calls on hold. Each bar represents a call on hold. In this example there are 3 calls on hold.
	More menu entries below.
	The  key has been pressed. The 2 nd function will be used for the next key pressed.
	A valid PIN code is required to use the terminal.
	The keypad is in alpha mode. Alpha mode is used to enter letters (for example names in the phone book). Note: This symbol does not indicate capital letters. The  key is used to toggle the Caps lock function.
	The value in a menu must be selected between certain predefined values by means of the  and  keys.

Symbol	Meaning
	The speaker. You can turn the external speaker on and off by pressing  . The  symbol is displayed in the LCD when the speaker is on.
	The handset is off hook

Function keys



The Function keys enable you to enter the menu system of the transceiver and change various settings.













The below list shows the meaning of the function keys.

Note

You access the second function of a key by pressing  before pressing the key.



















Key	Function
	Exit key: <ul style="list-style-type: none"> • In the Menu system, pressing Exit brings you back one level until the menu is completely exited. • When you are asked YES or NO by the system, pressing Exit is interpreted as a NO response. • When you are entering data into the transceiver, pressing Exit cancels the entry. • Second function: Leave the menu system.
	Speaker key: This key turns the external speaker on and off.

Key	Function
	<p>OK key:</p> <ul style="list-style-type: none"> • When in the main screen display, pressing OK enters the menu system. • When in the menu system, pressing OK enters the selected menu. • When entering data, such as phone numbers or PIN codes, pressing OK applies the entry. • When you are asked YES or NO by the system, pressing OK is interpreted as a YES response.
	<p>Clear key:</p> <ul style="list-style-type: none"> • The primary function is to clear the last entered digit. • Second function: Insert. The insert function is used to insert new phone book entries, etc.
	<p>Scroll up key:</p> <ul style="list-style-type: none"> • The primary function is to enable you to scroll up to menu items not shown on the 2-line display of the LCD. • Second function: Edit. The Edit function allows you to edit previously entered information, for example phone book entries.
	<p>ABC key:</p> <ul style="list-style-type: none"> • The primary function of this key is to toggle between normal mode and alpha numeric mode. • Second function: Delete. The Delete function allows you to delete previously entered information, for example phone book entries.
	<p>The 2nd function of the next key pressed will be applied.</p>

Key	Function
	<p>Scroll down key:</p> <ul style="list-style-type: none">• The primary function is to enable you to scroll down to menu items not shown on the 2-line display of the LCD.• Second function: Mute. The Mute function turns the handset microphone on/off.
	<ul style="list-style-type: none">• When pressed after a number,  initiates a call.• When pressed during a phone call,  ends the call.• When pressed without a connection and without any numbers entered,  shows a list of the ten last dialled numbers. When pressed again,  dials the selected number.

Second functions



A number of keys have a 2nd function. The following table gives a total overview of all the 2nd functions.

Keys	Function
 	Enters the top level of the menu system.
 	Transfers the call to a specified handset.
 	Places a call on hold.
 	Joins other handsets to a call.
 	Inserts an entry, for example in the phone book.
 	Edits an existing entry, for example in the phone book.
 	Deletes an existing entry, for example in the phone book.
 	Mute. Turns the handset microphone on/off.
 	Exits the menu system from anywhere in the menus.

Alpha-numeric keys

The keypad can be in normal (numeric) mode or alpha mode. Normal mode is used to enter digits (phone numbers) whereas alpha mode is used to enter letters (such as names in the phone book).

Switch alpha/numeric mode

The  key is used to switch between the two modes. The  symbol in the display indicates that the handset is in alpha mode.



Enter letters

In alpha mode you can use each of the numeric keys to select between subsets of the alphabet and certain special characters. To enter a letter, press the key a number of times until the wanted character is shown in the display. For example, to insert the letter C, you press the  key 3 times in alpha mode.

Caps Lock toggle











The  key is used as a Caps lock toggle when the handset is in alpha mode.

S Key

The  key is a special function key, which is normally used only in numeric mode.

Available characters in alpha mode

Below is an overview of the relevant keys in alpha mode.

Key	Available characters or functions in alpha mode
	- ? ! , . : ' \$ () + / 1
	A B C 2
	D E F 3
	G H I 4
	J K L 5
	M N O 6
	P Q R S 7
	T U V 8
	W X Y Z 9
	<space>
	Caps lock toggle

How to make calls from the Full Feature handset



Before making a call make sure the display shows “Ready” or that the service you want to use (H+ or SW 64) is available, i.e. the service LED for Classic Aero (H+) is lit.

Do as follows:

1. Type in the phone number with the prefix 00.

Example: To call Cobham SATCOM VA (+1 757 463 9557), press the number:

for Voice,
 for country code,
 then

2. Press , or to activate the call.

The display on the terminal handset shows how the call proceeds.

3. Hang up by pressing or placing the handset in the cradle. When the call is terminated, the display shows the duration of the call.

Example:

Connected:
 00:01:59

The phone book can also be used to initiate a call, either by selecting an entry in the phone book or by using the Quick Dial function.

Answer a call

Answering a call to the Full Feature handset can be done in two ways:





- If the handset is in the cradle, simply take the handset from the cradle to answer the call.
- If the handset is out of the cradle, press to answer the call.



To make a call using the phone book

The phone book can be used to initiate a call.

For information on how to insert or edit entries in the phone book, see *Use the SDU phone book* on page 115.



To make a call using the phone book, do as follows:

1. Press  or  to access the phone book from the main display, or enter the menu system and select PhoneBook.
2. Find the entry you need, either by scrolling the list with  or , or by pressing the key holding the first letter of the entry.

Example: To find an entry with the name Jones, press  once. To find an entry with the name Larsen, press  three times.

3. Press ,  or  to dial the selected number.



Quick Dial function

To use the Quick Dial function, press one of the  →  keys and hold it down for 1 sec. Each key is a shortcut to a user-defined entry in the phone book. For further information, see the section **System Setup, Quick Dial** on page 135.

To redial a number

To call the last used number, press  to show a list of the last ten numbers dialed from the handset.

Note | The list only shows the first 12 digits of each number.

Scroll through the list and press ,  or  to establish a call to the selected number.

Operate the Auxiliary handset

The Auxiliary handset is divided into 3 sections.

- *LEDs*: This section gives you visual indications about the operation and status of the system.
- *Function keys*: This section gives you access to a few call functions, such as transfer of calls, memory etc.
- *Alpha-Numeric keys*: This section enables you to dial numbers.

The Auxiliary handset also provides a volume control placed on the side of the handset.



LEDs

There are two LEDs on the Auxiliary handset.















- Left green LED: Lights constantly when the handset is off-hook.
- Right green LED: Flashes to indicate that the handset is ringing. When a connection is established, the LED is turned off.

Function keys

The function keys enable you to transfer calls, redial, store and recall phone numbers, and to mute the microphone.

Each function key is described in detail in the table below.















Key	Function
	Store number. This key is used to store phone numbers.
	Memory. This key is used to recall phone numbers from the memory.
	This key is used to put calls on hold.
	Memory location 1. (Same function as  )
	Memory location 2. (Same function as   <small>abc</small>)
	Memory location 3. (Same function as   <small>def</small>)
	Redial. This key is used to redial the last dialed number.
	Mute. This key is used to mute the microphone.
	Toggle hook. This key is used to toggle between on-hook and off-hook.

Alpha-Numeric keys

The numeric keys are primarily used to dial numbers or to enter numbers to be stored in memory.

Below is an overview of the available characters and functions.



Key	Available Characters or Functions	Key	Available Characters or Functions
	1		7 p q r s
	2 a b c		8 t u v
	3 d e f		9 w x y z
	4 g h i		Special function
	5 j k l		0
	6 m n o		This key is used to indicate the end of a phone number or to activate a call.

How to make calls from the Auxiliary Handset



Before making a call, make sure you hear a dial tone in the handset.

Making a call from an Auxiliary Handset connected to an analogue POTS phone interfaces is done in the same way as a call from a standard telephone, but always with the prefix 00 and **#** after the number to signal to the terminal, that the number is complete.

Example: To call Cobham SATCOM VA (+1 757 463 9557) first establish a connection by pressing **[hook]** or taking the handset off the cradle. Then press the following keys on the phone:

[0] **[0]** **[1]** **[7pqrs]** **[5jkl]** **[7pqrs]** **[4ghi]** **[6mno]** **[3def]** **[9wxyz]** **[5jkl]** **[5jkl]** **[7pqrs]** **[#]**

How to make **Internal calls** see *To make local phone calls (SDU)* on page 39.

To take a call

Taking a call to the Auxiliary handset can be done in two ways:

- If the handset is in the cradle, take the handset from the cradle to take the call.
- If the handset is out of the cradle, press **[hook]** to take the call.

To store a phone number

The Auxiliary handset can store up to 10 phone numbers, in memory location 0 to 9. The **[M1]**, **[M2]** and **[M3]** keys can be used for accessing memory location 1, 2 and 3, whereas the other locations are accessed using the MEM key followed by the number of the location.

To store a number using A, B and C, d, do as follows:

1. Press **[hook]** or take the handset off the cradle.
2. Press **[STO]**.
3. Enter the phone number you want to store, including country code.

4. Press **STO**.
5. Press **M1**, **M2** or **M3** depending on the memory location you want to save the number in.

The number is now available in the memory location you selected.

Example: To save the phone number of Cobham SATCOM VA in memory location 2, take the handset off the cradle and press the following keys:

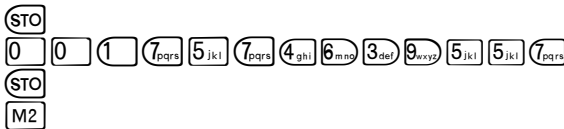

To store a number using the number keys, do as follows:



1. Press **☎** or take the handset off the cradle.
2. Press **STO**.
3. Enter the phone number you want to store, including country code.
4. Press **STO**.
5. Press one of the keys 0 to 9, depending on the memory location you want to save the number in.



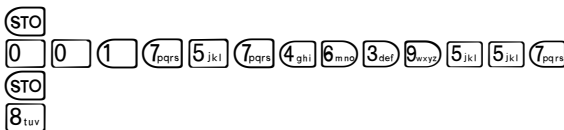

The number is now available in the memory location you selected.

Example: To save the phone number of Cobham SATCOM VA in memory location 8, take the handset off the cradle and press the following keys:





To recall a phone number from memory

To recall a phone number from memory location 1, 2 or 3 using the ,  and  keys, do as follows:



1. Press  or take the handset off the cradle.
2. Press ,  or , depending on which memory location you want.

The number saved in the memory location is dialled.



3. When calling from the SBU finish by pressing .



Example: To call the number saved in memory location 3, first establish a connection by pressing  or taking the handset off the cradle. Then press . The number saved in memory location 3 is dialled.

To recall a phone number from memory using the H and the number key, do as follows:



1. Press  or take the handset off the cradle.
2. Press  followed by the number of the memory location you want.
The number saved in the memory location is dialled.

3. When calling from the SBU finish by pressing .



Example: To call the number saved in memory location 8, first establish a connection by pressing  or taking the handset off the cradle. Then press  . The number saved in memory location 8 is dialled.

Note | Pressing  has the same effect as pressing  .

To redial a number

To call the last dialled number, first establish a connection by pressing  or taking the handset off the cradle. Then press  followed by .

To mute the microphone

To mute the microphone of the handset, press . To return to normal microphone function, press  again.

How to make a call with the Sigma⁷ handset

To make a call using the Sigma⁷ handset, do as follows:

1. Press the **On** key.
2. Type in the phone number with the prefix 00.
3. Press #.

Example: To call the number of Cobham SATCOM VA (+1 757 463 9557), press the **On** key followed by the number: **00** for Voice, **1** for country code, then **757 463 9557 #**.

- **To hang up**, press the **Off** key or place the handset in the cradle.
- **To answer a call**, take the handset out of the cradle and press the **On** key.

For further information on the functions of the Sigma⁷ handset, refer to: “Sigma⁷ Telephone Handset Manual”, PN# 500114.

Note

If you cannot adjust the handset volume correctly, it may be because the configuration of the AVIATOR 700 system and the configuration of the handset do not match. Please contact your Maintenance Center to have them reconfigure the system correctly.

How to make a call with the 2.4GHz Cordless handset

To make a call using the 2.4GHz Cordless handset, do as follows:

1. Type in the phone number with the prefix 00.
2. Press #.
3. Press the **TALK** key.

Example: To call Cobham SATCOM VA (+1 757 463 9557), dial:
00 for Voice, **1** for country code,
then **757 463 9557 #**, followed by the **TALK** key.

- **To hang up**, press the **END** key or place the handset in the cradle.
- **To answer a call**, take the handset out of the cradle and press the **TALK** key.

For further information on the functions of the 2.4GHz Cordless handset, refer to: "2.4GHz Cordless, Installation Manual", PN# 500484.

How to make a call from an ISDN phone

Making a call from a phone connected to the ISDN interface is similar to making a call from the POTS handset, that is, you have to press **#** to indicate the end of the number.

Example: To call Cobham SATCOM VA (+1 757 463 9557), establish a connection by pressing  or taking the handset off the cradle.
Then dial: **00 1 757 463 9557 #**.

Operate the AVIATOR Wireless Handset

See the AVIATOR Wireless Handset User Manual.

Use a SIP-enabled IP handset (SBU)

SIP-enabled wireless IP handset

The SBU of the AVIATOR 700 system has an integrated SIP server. If your mobile phone is a SIP-enabled IP handset, it has a SIP client. Then you can set it up and use it to make phone calls or use other data services using the SwiftBroadband service.

Note

Check whether your mobile phone or Smart Phone has a wireless interface and an integrated SIP client.

Once set up, you can use the SIP-enabled IP handset as a local phone during flight. When calling you use the SwiftBroadband service. The call costs will be charged to the SwiftBroadband subscriber. The call receiver will be called up from the system's 870 number.

When your device is connected to the SIP server of the AVIATOR 700 system you cannot be called at your own mobile number and you cannot send or receive SMS messages.

To set up a SIP-enabled wireless IP handset (SBU)

To set up a SIP-enabled IP handset, do as follows:

1. Connect to the Wireless access point of the AVIATOR 700 system. Check that the WLAN icon in the handset display indicates that the WLAN connection has been established. If your WLAN is encrypted check with your system administrator how to proceed to access the encrypted WLAN network.
2. Connect to the SIP server of the AVIATOR 700 system. See the user manual of your IP handset for guidelines how to establish a connection to a SIP server.

For this you need to enter the following details into the device:

- SIP server name, port and address, default: 192.168.0.1
- User name
- Password
- Codec priority
- Realm

User name: When connecting to a SwiftBroadband Unit, the user name should be a local number, i.e. 05xx. This must be configured in the built-in web interface under **SETTINGS > IP handsets**.

Password: When connecting to a SwiftBroadband Unit, the password is the local number for this phone. It is a number in the range of 0501 to 0516 which is not yet assigned to other IP phones. The password must match the IP Handset password entered in the SwiftBroadband Unit.

Codec priority: Select the codec type that should have the highest priority. You may select G.711 A-LAW.

Realm: When asked for Realm enter the serial number of the AVIATOR 700 SBU.

Having established this connection you can make calls with SIP-enabled IP handset and it can be called to, also as a local phone of the AVIATOR 700system.

Note | All charges for calls and data sessions are billed to the AVIATOR 700 system.

Use the MCDU

Operate the MCDU

The MCDU is used to control and operate the SATCOM equipment from the cockpit. A subset of the MCDU menus and functions are identical to those of the Full Feature handsets. The following sections describe the AVIATOR 700 menu functions of the MCDU and explain how to navigate the MCDU.

Note

This chapter only describes the part of the MCDU functions that concerns the AVIATOR 700 system. For information on other functions in the MCDU, refer to the documentation delivered with your MCDU and, if relevant, with any other connected equipment.

MCDU display

The MCDU display holds 14 rows of 24 characters each. The top line is the title line and the bottom line (the Scratch Pad) is used to display messages to the crew and to show keyboard entry of data.

If the contents consist of multiple pages, the current page and total number of pages are displayed on the first line. Press the keys **NEXT** and **PREV** to view all pages.

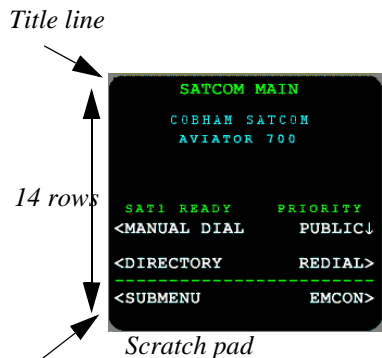

Navigation: Display text and symbols

The below list shows the meaning of most of the various symbols and texts that may appear in the display.

Symbol/Text	Meaning
< or >	These symbols appear next to the arrow keys (▶ ◀). The name next to this symbol indicates a new page. Pressing the arrow key next to this symbol opens the new page, e.g. a submenu.
*	This symbol (star or asterisk) appears next to a key if pressing that key causes the activation of a function. The displayed page may also change as a result.
↓	This symbol indicates the currently selected parameter in a list. Pressing the arrow key next to this symbol toggles between the settings available.
MAIN	Pressing the arrow key next to MAIN causes the display to exit the menu system and go to the top-level page.
RETURN	Pressing the arrow key next to RETURN causes the display to go up one level in the menu system.
ACTIVE ERRORS	If an error has occurred, this text is shown. Press the key next to ACTIVE ERRORS to see a list of currently active errors.
INCOMING CALL	If there is an incoming call, this text is shown. Press the key next to REJECT to reject the call, or the key next to ACCEPT to accept it.

MCDU keys

The below list shows the most important key functions in the MCDU. Note that some keys may be marked differently, depending on the type of MCDU.

Symbol/Text on key	Function
MENU	Enters the top-level menu. In this menu you can select SUBMENU .
▶ or ◀ (arrow keys)	Opens a new page, changes parameters or activates a function, depending on the symbol next to the key. For further information, see Display text and symbols on the previous page.
NEXT	Opens the next page, if the current menu or list contains more than one page. The top right corner of the display shows whether there are more pages. Example: 1/3.
PREV	Opens the previous page, if the current menu contains more than one page.

To enter the SATCOM subsystem

To enter the **SATCOM** subsystem of the MCDU, do as follows:

1. Press the **MENU** key.

The display shows a list of connected devices (subsystems).

Note | Depending on the type of MCDU, the **MENU** key may have a different name. Refer to the documentation for your MCDU.

2. Press **▶** next to the name of your connected **AVIATOR 700** system.

If you want to change the device name shown in the display, use the **Aero-SDU Configuration Program**.

When the **SATCOM** subsystem is selected, the display shows the menu **SATCOM MAIN** after a successful **POST** and calibration procedure. Once in the **SATCOM** subsystem, the title line of the display shows the name of the current menu.

Note | During the start-up of the **AVIATOR 700** system, that is when the **POST** and calibration procedures are running, the **Main** menu will not be ready

Automatic logon

When the system has completed its initialization, and if the logon policy is set to automatic, the system will initiate the logon procedure. Upon successful logon, the MCDU display shows:

For further information on this menu see *AVIATOR 700 main menu* on page 150. For the complete MCDU **AVIATOR 700** menu tree see *Menu trees* on page 211.

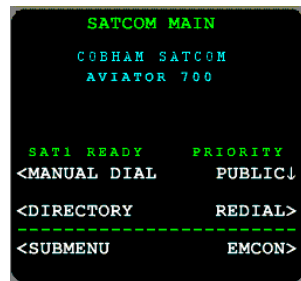

Manual logon

When the system has completed initialization, and if the logon policy is set to manual, the system will stay logged off and wait for user input. In this case, only a subset of the features in the main menu is available.

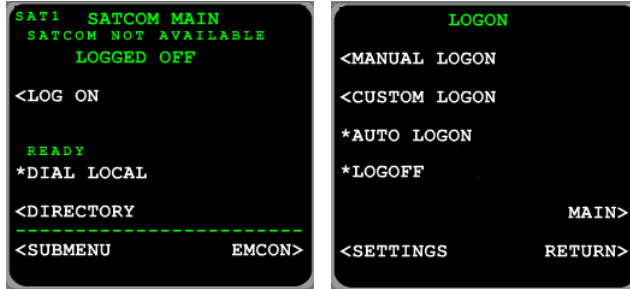

Select the **LOG ON** menu to proceed. For further information on this menu see *LOGON menu* on page 153.

Make or receive a phone call (MCDU)

This section explains how to make a call from the MCDU. Call routing from and to the cockpit can be configured as described in *To select the default outgoing call type (SDU)* on page 35 and *To select the incoming call type (SDU)* on page 36.



Note

There are two modes for activating or terminating a call: Latched or Push-To-Talk (PTT). This is set-up in the Aero-SDU Configuration Program.

In **PTT** mode you can activate a call by pushing the PTT button or using the keypad of the MCDU as described below. If the system is in **Latched** mode, you must use the switch to activate and terminate the call.

To make a call (air to ground) (MCDU)

You can dial a phone number from two views in the MCDU:

- Main menu
- **MANUAL DIAL** menu

The main menu is shown here.

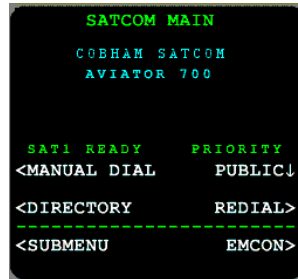

To make a call, do as follows:

1. Dial **00 <country code> <phone number>** using the numeric keys on the MCDU and select **CALL**¹.

Example: To call the phone number 39558681 in Denmark, Europe, that has the country code 45 press 004539558681 and then press **CALL**.

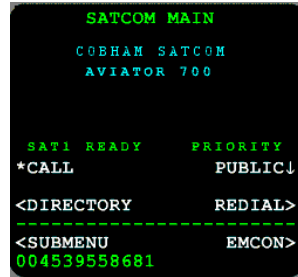

2. To terminate the call, select **TERMINATE**¹ or use the latch key.

While having an active call, the volume can be adjusted from main menu, or the submenu **MORE**, you can put the call on hold, transfer it or join a conference call. For

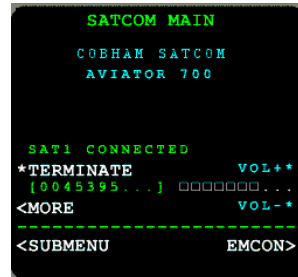

Further information see *To hold a call (MCDU)* on page 92, *To transfer a call (MCDU)* on page 92 and *Conference call (MCDU)* on page 93.

If the outgoing call type (see also *Select a call type (SDU)* on page 34) is Standard Voice (H⁺), a Classic Aero Call Priority can be assigned to the call. For more information on call priorities see *AVIATOR 700 main menu* on page 150.

1. If in latched mode, activate the call by switching on the Mic Switch.

Important

It is recommended to use default call routing for cockpit audio to avoid the risk that an emergency call can be routed as a Swift64 call.

If you select an H+ call priority higher than Public, other calls with lower priority will automatically be released in case of congestion in the aircraft system or in the Inmarsat network.

From the **MANUAL DIAL** menu, you can override the default outgoing call type. Configure the Call Priority before selecting **CALL**. Use the arrow key next to **Call Type** to select between the settings available. The types are listed here:

- Auto. The default outgoing call type is used, see also *Select a call type (SDU)* on page 34.
- H⁺. Use only the Classic Aero (H⁺) service (Standard Voice).
- HSD. Use only the Swift64 (HSD) service.

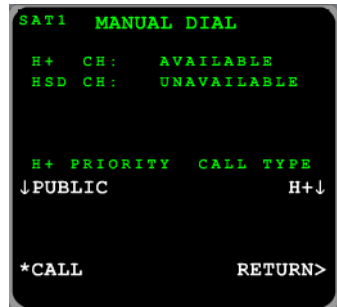

To receive a call (MCDU)

By default, all devices connected to the 4-Wire interfaces, 2-Wire interface and the ISDN interface will ring when one of the mobile numbers is called. Note, however, that this depends on the configuration of incoming calls made during initial configuration of the system. For further information, see the AVIATOR 700 Installation and maintenance manual and the online help of the Aero-SDU Configuration Program.

To make a call (ground to air) (MCDU)

For information how to make a call to the system see *Phone number for a call (ground to air) (SDU)* on page 38.

To make a local phone call (MCDU)

You can make a local phone call from several views in the MCDU:

- Main menu
- **MANUAL DIAL** menu

You can also make local calls when the system is logged off the satellite services.

To make a local phone call, do as follows:

1. To make a local phone call dial the interface code and select **CALL**¹
For a list of interface codes, see *Special-purpose and local numbers* on page 40.
2. To make a local broadcast to all connected phones use interface code 0 and select **CALL**¹.

To make a call using the phone book (MCDU)

The phone directory contains the prioritized subdirectories Emergency, Safety, Non-safety and Public. Emergency has the highest priority, Safety the second-highest and so forth. The Public directory is also accessible from the Full Feature handsets.

Important

If you select an H+ call priority higher than Public, other calls with lower priority will automatically be released in case of congestion in the aircraft system or in the Inmarsat network.

To call a number in the phone book, do as follows:

1. Enter the **DIRECTORY** menu from the main menu.

1. If in latched mode, activate the call by switching on the Mic Switch.

2. Select a call priority: **EMERGENCY**, **SAFETY**, **NON_SAFETY** or **PUBLIC** to display the phone book entries for this call priority. If you want to override the call type press **Auto** and select **H⁺** or **HSD**.

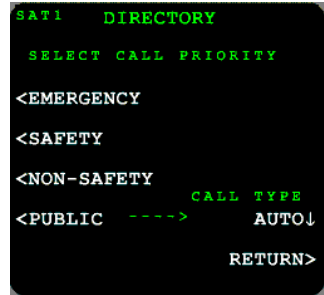

3. Select the number you want to call¹. The display lists all numbers assigned to the selected call priority. If there is more than one page, use the keys **PREV** and **NEXT** to scroll through the pages.

To redial a number (MCDU)

To **redial** a number, do as follows:

1. Select **REDIAL**. The display shows a list of the last 10 called numbers.
2. Select the number you want to dial.²
A call to the selected number is activated.

Note | Systems with two MCDUs share the redial list.

To handle incoming calls using the switchboard (MCDU)

The switchboard makes it more straight forward to handle incoming calls. When an incoming call is established, do as follows:

1. Enter the menu **MORE** and select **SWITCHBOARD**.
The display shows a list of all connected handsets and their current states:
 - **READY** — the handset is free for a call.
 - **BUSY** — the handset is currently used for a call.

-
1. If in latched mode, activate the call by switching on the Mic Switch.
 2. If in latched mode, activate and terminate the call by switching the Mic Switch.

2. Press the key next to the handset you want to talk to and wait until the handset you just selected answers the call.
3. Select **CONFERENCE** to add the handset to the conference call or **TRANSFER** to put the call through to the handset.

To hold a call (MCDU)

When the connection is established, you can put an incoming, outgoing or local call on hold. To put a call on hold do as follows:

1. Enter the **MORE** menu (accessible from the main menu).
2. Select **HOLD**.

The display shows that the call is put on hold. After a call has been placed on hold, a new call can be initiated.

Note | Only one call can be on hold at a time.

To reactivate a call placed on hold, do as follows:

1. Enter the **MORE** menu (accessible from the main menu).
2. Select **UNHOLD**.

To transfer a call (MCDU)

To transfer an incoming or outgoing call to a local phone connected to the SDU do as follows:

1. Establish a connection to the incoming or outgoing call.
2. Enter the menu **MORE** and select **HOLD**.
3. Press the interface code and select **CALL**. For a list of interface codes, see *Special-purpose and local numbers* on page 40.
4. Enter the menu **MORE** and select **TRANSFER**.

To transfer a local call to another local phone or an outgoing call do as follows:

1. Establish a connection to the local phone.

2. Enter the menu **MORE** and select **HOLD**.
3. Press the interface code of the local phone or the phone number of an outside phone and select **CALL**.
4. Enter the **MORE** menu and select **TRANSFER**.

Note | It is not possible to transfer an outgoing/incoming call to a second outgoing/incoming call. At least one party must be a local phone connected to the SDU.

Conference call (MCDU)

You can establish a conference between three or more phone parties.

Note | Max. 6 lines can be connected, including handsets on the aircraft and lines to the ground.

When a call is already established, do as follows to add additional parties:

1. Enter the menu **MORE** and select **HOLD**.
2. Press the interface code of the local phone or the phone number of an outside phone and select **CALL**. For a list of interface codes, see *Special-purpose and local numbers* on page 40.
3. Enter the menu **MORE** and select **CONFERENCE** to add the handset to the conference call.
4. To add more parties to the conference call, repeat steps 1 to 3.
5. To leave the conference, select **TERMINATE** from the main menu.

Note | When the last local phone exits the conference call, the conference call is terminated even though there may be two or three active incoming or outgoing callers.

SMS service



Introduction

The SMS service provided by the SBU lets you send and receive short text messages from and to the satcom system. These messages are public and stored in the system, they can be viewed by all system users. The SMS service is also used to alert you that a voice mail has been received.

This message service does not manage personal SMS messages to and from personal IP devices.

To send an SMS message

You can send and receive SMS messages using the SBU of the AVIATOR 700 system. To do this you must connect a computer to the system using a LAN or WLAN connection and access the web interface.

To send an SMS message **from** the system, do as follows:

1. Access the web interface from a connected computer, open a browser and type the address: **http://192.168.0.1** (default). The **DASHBOARD** page is displayed.
2. Click **MESSAGES** from the left navigation pane. This page contains new incoming messages. On this page you can archive the messages and move them to the Inbox or you can delete a message.
3. In the left navigation pane, click **Write message**.

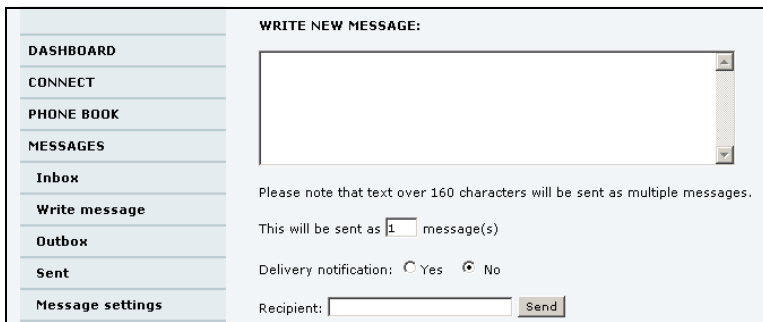

4. Type in the message in the **Write new message** field.
If the message text is too long for one SMS, the message is sent as two or more SMS messages. The field below the message field shows the number of SMS messages used to send the message.
5. Type in the phone number in the **Recipient** field.
Remember **00** or **+** and **country code** (e.g. **00 45** to call Denmark or **00 1** to call USA).
6. Select whether or not you want **Delivery notification** for this SMS message.
If you click Yes, the Status column in the Sent folder will show the status of your message when it has been sent.
You can set up delivery notification generally for all SMS messages. This setting is used by default when you send a message. For further information, see *Configure message settings* on page 99.
7. Click **Send**. The message is now sent and moved to the Sent folder.

Important

If the system is not online when you attempt to send a message, the message is moved to the Outbox instead of the Sent folder. Messages in the Outbox are **not** automatically sent when the system goes online. For further information on the Outbox, see the next section, *Options for messages in the Outbox*. To make sure a message has been sent, check that it has been moved to the Sent folder.

One SMS messages can have 160 characters. However, the system will allow you to input a longer message, which will then be divided up and sent as multiple SMS text messages. Have this in mind when you write messages. The more messages you have to send, the more transferred data you are charged for.

Options for messages in the Outbox

Messages in the Outbox are messages that have not been sent, e.g. because the system was not online when you attempted to send the messages. To access the Outbox, click **MESSAGES > Outbox** from the navigation pane. You have the following options for messages in the Outbox:

- When the system is online, click **Resend** next to the message you want to send. When the **Write message** page opens, click **Send**.

The system now attempts to send the message again. To make sure the message has been sent, look in the Sent folder.

Note

The original message remains in the Outbox. When you have succeeded in sending the message you may want to delete it from the Outbox.

- Click **Delete** next to a message to delete it.
- Click **Delete all messages in Outbox** to delete all the messages.

Handle messages

Options for messages in the Sent folder

The Sent folder contains SMS messages that have been sent. To access the Sent folder, select **MESSAGES > Sent** from the navigation pane. The Status column shows the status of each message, if you have selected Delivery notification when sending the message. From the Sent folder you have the following options:

- Click **Resend** next to a message you want to send again.
When the Write message page opens, click **Send**.
The system now attempts to send the message again. To make sure the message has been sent, look in the Sent folder. There should now be two copies of the sent message.
- Click **Forward** next to a message you want to forward.
Type in the phone number of the new recipient and click **Send**.
The system now attempts to send the message to the new recipient. To make sure the message has been sent, look in the Sent folder.
- Click **Delete** next to a message to delete it.
- Click **Delete all sent messages** to delete all the messages.

To send an SMS message to the system

You can send an SMS message to the system e.g. from a mobile phone, using one of the system's mobile numbers for voice. Dial

+ <Mobile number>

The first part of the mobile number is always 870, which is the “country code” for the BGAN system. If the mobile numbers are listed in the web interface, you can look them up as follows:

Select **PHONE BOOK > Mobile numbers**. If the mobile numbers are not listed in the web interface, refer to your service provider.

Note

There are two Voice numbers, one for 3.1 kHz Audio and one for Standard Voice.

To receive a message

If a message has arrived, the icon bar at the top of the web interface shows an unopened envelope. Click the envelope to see the new message(s).



Otherwise, to see new messages click **MESSAGES** from the left navigation pane. The page shows new incoming messages.

The message icon disappears when all the messages on this page have been archived or deleted.

Note

The system does not accept more than 100 incoming messages (including read and unread messages). If you have received 100 messages, you have to delete some of them in order to free space for new messages. Otherwise, the new messages are rejected.

If the message is not an SMS message but information of voice mail, call your voice mail service number to hear the voice mail. The voice mail number is displayed together with the message.

When using the voice mail service for the first time you must configure your voice mailbox with your welcome greetings. Follow the instructions given by the voice mail system.

To find your voice mail number, select **MESSAGES > Message settings** from the left navigation pane and locate the **Voice mail number**.

Note that the voice mail number is only shown if it is available on the SIM card. Otherwise, refer to the information from your service provider.

Options for new SMS messages

To see new messages, click **MESSAGES** from the left navigation pane. Besides viewing the new messages, you have a number of options for what to do with each message:

- Click **Read** to move it to your Inbox containing read messages.
- Click **Reply** to reply to a message.
Then type in your reply and click **Send**.
For information on how to include the original message in your reply, see *To set up the default message options* on page 99.
- Click **Forward** to forward a message to someone.
Then type in the phone number in the **Recipient** field and click **Send**.
- If you want to move all the new messages, click **Move all new messages to Inbox**.

Note

New messages cannot be deleted until they have been archived and moved to the Inbox.

Options for SMS messages in the Inbox

The messages in the Inbox are the incoming messages that have been archived from the list of new messages. From the Inbox, you have the following options:

- Click **Reply** to reply to a message.
Then type in your reply and click **Send**.

For information on how to include the original message in your reply, see *To set up the default message options* on page 99.

- Click **Forward** to forward a message to someone. Then type in the phone number in the **Recipient** field and click **Send**.
- Click **Delete** to delete the message, or **Delete all messages in Inbox** to delete all read messages in the Inbox.

Configure message settings

To set up the default message options

You can set up general options for outgoing messages. These settings apply by default to all outgoing messages. Note, however, that you can change the Delivery notification setting for an individual message. For further information, see *To send an SMS message* on page 94.

To set-up the default message options do as follows:

1. Select **MESSAGES > Message settings** from the left navigation pane.

SMS service center: +870772001799 [Edit](#)

Voice mail number: +870772001899

Include message in reply: Yes No

Delivery notification: Yes No

2. If you want to include the original message when you reply, select **Yes** next to **Include message in reply**.
3. Select whether or not you want **Delivery notification** for SMS messages.

If you click Yes, the Status column in the Sent folder will show the status of your message when it has been sent.

4. Click **Apply**.

To view or change the SMS service center number

The SMS service center number identifies the SMS service center used when sending and receiving SMS messages. The SMS service center is used when you send a text message (SMS message) to another user. The message is stored in the SMS service center which delivers it to the destination user when they are available.

The SMS service center number is stored on the SIM card.

- To see the SMS service center number, select **MESSAGES > Message settings** from the left navigation pane.
- To change the number, click **Edit** next to **SMS service center**, change the number and click **Save**. Then click **Apply** to apply all changes in the page.

The SMS service center number is provided from your service provider.

Use a computer

Note

In the standard setup, data services are provided by SwiftBroadband. This service is available exclusively on I4 satellites. For areas where there is no I4 coverage the AVIATOR 700 system can use Swift64 as a fallback solution for data services.

Use a computer over SwiftBroadband



Selected scenarios

The application examples in this chapter are mainly based on the default configuration and some typical application scenarios. If you have specific requirements to the interface setup and configuration of your system refer to the AVIATOR 700 Installation and maintenance manual.

Tool for setup and use: The web interface

Use the built-in web interface of the SwiftBroadband Unit (SBU) to access the system settings. The web interface is accessed from a computer connected to one of the LAN connectors or using the WLAN interface of the SBU. The web interface is shown in an Internet browser. No additional installation of software is needed.

In this manual you find information and instructions for the parts of the web interface that you might need when using the system. The parts of the web interface that deal with installation, configuration or maintenance are described in detail in the AVIATOR 700 Installation and maintenance manual.

The following drawing shows the menus available in the web interface. The topics in gray are mainly used during installation and maintenance of the system, they are described in detail in the AVIATOR 700 Installation and maintenance manual.

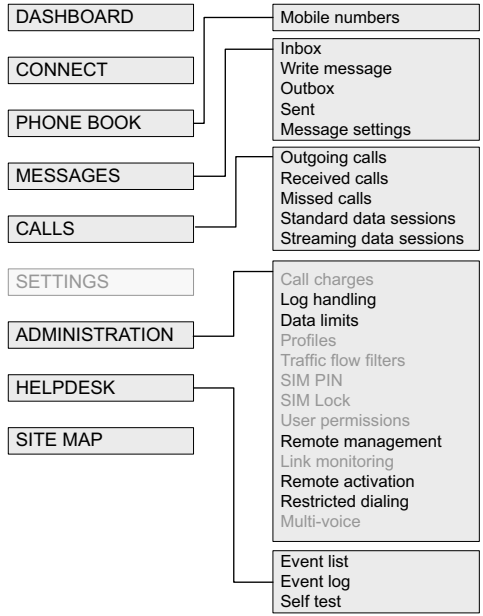

For more detailed information see *Use the SBU web interface* on page 164.

Services and interfaces

The following table shows the supported combinations of services and interfaces, and which types of equipment can be used.

Service		Interface on the system		
		Phone/Fax (RJ 11)	LAN (RJ 45) or Wireless	ISDN (RJ 45)
Circuit Switched	3.1 kHz Audio	Analog telephone	AVIATOR Wireless Handset or other SIP-enabled IP handset	ISDN telephone
		G3 Fax machine		G4 Fax machine (If it supports G3 Fax)
		Secure telephone STU/FNBDT		
	Standard Voice (AMBE)	Analog telephone	AVIATOR Wireless Handset or other SIP-enabled IP handset	ISDN telephone
	Data, UDI or RDI ^a			G4 fax machine or computer with ISDN modem
Packet Switched	Data multi-user		Computer or Smart Phone	
	Data single-user		Computer or Smart Phone	
SMS			Computer with web interface	

- a. Check with your service provider that the RDI service is available on the Ground Infrastructure network.

LAN and WLAN interfaces

If the Built-In Router option is activated you can connect several PCs and other IP devices to the AVIATOR 700 system. Then the system operates as a router. It handles IP data traffic so the AVIATOR 700 system can be used with multiple computers for e-mail, Internet access, VPN, intranet and other applications that use the packet switched connection.

If you have purchased the Wireless Option you can connect multiple computers and other IP devices to the system via the Wireless Access Point. For more information on these options see *Built-in router and Wireless options* on page 8.

To connect a computer to the SBU you have several possibilities:

- Use one of the six LAN connectors (Ethernet) to connect user computers or other LAN equipment. Check how many of the LAN connectors are available in your installation and where to find them in the cabin.
- If installed, use the Wireless Option to connect computers and other devices using IP to the network.

There is also the front Maintenance connector on the front plate of the SwiftBroadband Unit. This connector is typically not accessible during flight. It is reserved for service and maintenance purposes.

Customize network use

With the built-in router functionality the AVIATOR 700 system offers a flexible use of the data channel of the SwiftBroadband service. The system administrator can configure the use of the data channel by defining network user groups and profiles. The following picture gives an overview over the parameters and functions involved.

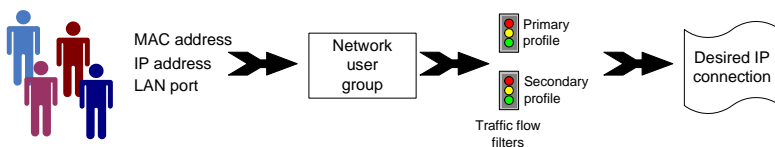

An IP device that is connected to the AVIATOR 700 system will automatically be assigned to the default network user group, if it is not specified otherwise. The default setting of this group is a standard data connection with automatic IP address allocation and automatic activation of the connection.

The AVIATOR 700 system is flexible and can be configured to specific requirements for your network use, e.g. manual activation of the Internet connection, activating video streaming, a server on the network or a fixed IP address on one of the devices. For this you need to set-up network groups with specific primary and/or secondary profiles. You can find detailed description in the AVIATOR 700 Installation and maintenance manual.

Network user groups

To manage the use of the bandwidth and the applications allowed for the individual user the system administrator can set up network user groups. The following paragraphs describe how network user groups are used in the AVIATOR 700 system.

When you connect an IP device (a computer, Smart Phone, etc.) to the SBU the system will find out which network user group the device belongs to. To do this the system uses the following information:

- The **port** the device is connected to, i.e. one of the 6 Ethernet ports, Wireless or the SBU maintenance connector (reserved for service and maintenance).
- The device's **IP address**.
- The device's **MAC address**.

In the default configuration of the network user group called DEFAULT GROUP a specific IP address or the unit's MAC address are typically not needed. The DEFAULT GROUP uses the background IP data connection.

If you want to read more about how to customize the AVIATOR 700 system and how to set up network user groups and traffic profiles to meet specific data traffic requirements see the AVIATOR 700 Installation and maintenance manual.

Connect to the Internet

You can connect your PC or other IP devices e.g. your Smart Phone to the Internet and use e-mail, VPN, file transfer applications etc. The following sections describe two typical applications: Starting a standard data connection and a streaming data connection.

Access the web interface in the AVIATOR 700 system

When the computer and the AVIATOR 700 system are ready you can access the built-in web interface of the system to display various information, use the SMS service or start and stop a data connection.

To check the connection of your computer to the web interface of the system do as follows:

1. Power up your computer.
2. **For LAN:** Connect your LAN cable (standard Ethernet) between the network connector on your computer and one of the LAN connectors installed in the aircraft.
For WLAN: Check that the WLAN icon in the status bar of your operating system indicates that the WLAN connection has been established. If your WLAN is encrypted check with your system administrator how to proceed to access the encrypted WLAN network.
3. Open your Internet browser and enter the default IP address of the AVIATOR 700 system: **http://192.168.0.1**.
You may have to disable the Proxy server settings in your browser. For further information, see *Proxy server settings* on page 165.

4. The web interface opens and the page **DASHBOARD** is displayed. On the Dashboard you see the current system information.

DASHBOARD	PROPERTIES	SESSIONS TOTAL
CONNECT	Airtime provider: Swift	Standard voice inbound: 01:28:39
PHONE BOOK	GPS position: N 55°48', E 12°30'	Standard voice outbound: 03:35:40
MESSAGES	Status: Ready	3.1 kHz audio inbound: 00:02:30
CALLS	Satellite selection: Auto	3.1 kHz audio outbound: 00:08:45
SETTINGS	Current satellite: EMEA (elevation: 25°)	Standard data: 31.12 MB
ADMINISTRATION	Unit serial number: 11443372	Streaming 8 kbps: 00:00:00
HELPDESK	Software version: 2.02	Streaming 16 kbps: 00:00:00
SITE MAP	Certification level: Level-D	Streaming 32 kbps: 00:00:00
	IMSI number: 901112115106122	Streaming 64 kbps: 00:03:40
	IMEI number: 35872303-000340-9	BGAN X-Stream: 00:09:17
	ONGOING DATA SESSIONS	ONGOING CALLS
	(No active data sessions)	(No active calls)
	PROFILES ON LAN (DEFAULT GROUP)	
	Start Standard	Start Streaming 64
	Start BGAN X-Stream	Start Streaming 128
	<input type="button" value="Refresh"/>	

You can configure the AVIATOR 700 system to your specific requirements. This is typically done during the installation and initial setup of the system. See the AVIATOR 700 Installation and maintenance manual for detailed information how to customize the interfaces of the system and how to set up network user groups and profiles to manage data traffic and bandwidth usage.

Unintended use of bandwidth

The system default setting is automatic activation of a standard data connection. With this setup you connect the PC to the cabin network and start using the applications. You do not have to connect to the web interface to start using the services, it is plug-and-play. This setting involves a high risk of being charged for airtime and bandwidth when connected computers perform automatic software updates. These updates are not

limited to the Windows system itself, but also other installed programs (e.g. browsers, Java and Media or Flash players) might do updates. Some do updates even without prompting before the download is complete.

Note

Online software updates of the connected devices (PC, smartphone etc.) should only be performed when you are connected at the office or at home where bandwidth and airtime are less costly. Check the documentation for the device how to disable automatic software updates.

To avoid unintended use of bandwidth through automated background services the system can be set to **not** automatically connect to the Internet when you connect your computer or other IP equipment (PDA, smartphone, webcam, etc.) to the network interface. You set this in the web interface.

However, selecting manual activation alone will not prevent these updates, but only delay them until the connection is activated. The only way to be sure is to disable updates in all programs, which can be a difficult task. Please check with you IT department for assistance on this. If you want to start a data connection in this mode you must access the system's web interface and activate your data session, standard IP and/or streaming IP, from the Dashboard.

Note

Optimize airtime and bandwidth usage: You are charged for the bandwidth used for automatic software updates. We recommend to disable this feature in your computer.

Understand Standard and Streaming data connections

The BGAN network supports different types of IP data connections to the Internet. There is Standard data and Streaming data. The figures on this page show how the bandwidth of 432 kbps with a high-gain antenna is used

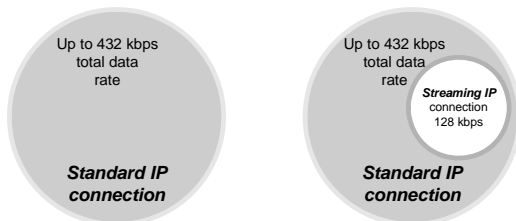

when set-up as Standard connection (left) and as Standard and Streaming 128 kbps (right).

- **Standard data** connection: All users that have signed on the network share the bandwidth available. This type of connection is ideal for TCP/IP traffic such as e-mail, file transfer, and Internet and intranet access. Standard data services are charged by the volume of data transferred.
- **Streaming data** connection: You get a guaranteed, high-priority connection, ensuring seamless transfer of data with guaranteed bit rate and Quality of Service. This type of connection is ideal for time-critical applications like live video over IP. Streaming classes are charged by the time the service is being used (per minute charge).

Note

You must always close the Streaming connection manually to finish the connection properly. You must click **Stop streaming** in the web interface to close the streaming connection. It is not enough to disconnect the equipment. As long as the connection is active you are charged for the service.

The system administrator can set up various types of connections using network user groups, profiles and traffic flow filters. For information on this see the AVIATOR 700 Installation and maintenance manual.

Data sessions available for the current user are displayed under **PROFILES ON LAN** or **STREAMING PROFILES ON LAN** at the bottom of the **Dashboard**.

The AVIATOR 700 system supports the use of network user groups. These network user groups define which type of IP connections are allowed for each group. Each network user group has then one or more profiles for various applications. You can only see, start and stop profiles of the network user group you belong to.

Note

The system administrator can start and stop data sessions for all network user groups, see also *Start or stop any data session* on page 179.

ONGOING DATA SESSIONS (No active data sessions)	ONGOING CALLS (No active calls)
PROFILES ON LAN (Default group)	
Start Standard	
<input type="button" value="Refresh"/>	

- Primary profiles are listed in the left side and secondary profiles (if any) are listed to the right.
- Profiles that are currently active are displayed as a link with the text “Stop <name of profile>”.
- Profiles that are ready to be activated are displayed as a link with the text “Start <name of profile>”.

Start or stop a Standard connection

On the Dashboard you can see under PROFILES ON LAN whether a standard connection is active or not. To start or stop a Standard connection for your Network user group do as follows:

1. Open your Internet browser and enter the IP address of the AVIATOR 700 system (default: http://192.168.0.1) to access the Dashboard of the web interface.
2. Locate **PROFILES ON LAN** at the bottom of the page.
3. Click **Start <name of profile>**, in this case: **Start Standard**, or **Stop <name of profile>** to stop the connection.

ONGOING DATA SESSIONS (No active data sessions)	ONGOING CALLS (No active calls)
PROFILES ON LAN (Default group)	
Start Standard	
<input type="button" value="Refresh"/>	

Note

If a primary profile is already active, your new profile will not appear as a link but as plain text. The active primary profile is displayed as a link with the text “Stop <name of profile>”. Click this link first to stop the active profile. Then click your new profile, which is now displayed as a link, to start your new profile.

Start or stop a Streaming connection

The AVIATOR 700 system supports 8, 16, 32, 64 and 128 kbps streaming classes. Note that streaming classes are charged by the time the service is being used (per minute charge). A started Streaming session will stay active until you manually stop it. On the Dashboard you can see whether the network user group you belong to has been set up to support streaming sessions.

Note

You can only start a Streaming session if the administrator has set up a Streaming profile for your user group. Contact your system administrator if you need a streaming connection.

To start or stop a Streaming session do as follows:

1. Open your Internet browser and enter the IP address of the AVIATOR 700 system (default: <http://192.168.0.1>) to access the Dashboard of the web interface.
2. Locate **STREAMING PROFILES ON LAN**.
3. Click the link with the name of the Streaming profile that has been set up for you.

ONGOING DATA SESSIONS	ONGOING CALLS
(No active data sessions)	(No active calls)
STREAMING PROFILES ON LAN (Group 0)	
Start Streaming 128	
<input type="button" value="Refresh"/>	

Note

If a primary profile is already active, your new profile will not appear as a link but as plain text. The active primary profile is displayed as a link with the text “Stop <name of profile>”. Click this link first to stop the active profile. Then click your new profile, which is now displayed as a link, to start your new profile.

Important

If you have selected and started a Streaming connection as your primary profile, the LAN or WLAN interface will be running a Streaming connection until you stop it. It is not enough to disconnect the equipment from the interface.

Always manual activation of a Streaming connection

The streaming data connection cannot automatically be activated, you must start it manually in the web interface. This is a safety measure to prevent the system from unintended use of bandwidth. A started Streaming session will stay active until you manually stop it in the web interface.

Use a computer over Swift64

Note

ISDN and MPDS services are only available when the aircraft is positioned inside an area with Spot Beam coverage (for regions with I3 coverage).

For detailed instruction how to set-up an ISDN or MPDS connection, an analogue modem connection and make a dial-up connection to the network see *Swift64 and H+ Data Service, Supplement to AVIATOR 700 and HSD+ User Manual, available for download*. (Order number: 98-130578)

System operation

In this chapter

In this chapter you can read about:

- *Full Feature handset operation (SDU)*
- *MCDU operation*
- *Use the SBU web interface*

Full Feature handset operation (SDU)

This section describes how to access the menu system using the keys and display of the Full Feature handset.

- *Use the SDU phone book*
- *Handset Setup*
- *Ring Profile*
- *Lock System*
- *Logon Menu*
- *System Setup*
- *Status*
- *Maintenance (reset)*

For an overview of all the menus, see *Menu trees* on page 211.

Access and exit menus

- **To access the menu**, press **OK** or **2nd** **Menu**.
When you are in the menu system you may also press **2nd** **1** to reach the top level of the menus.
- **To scroll through the menus**, use the **↑** **Edit** and **↓** **Mute** keys.
- **To enter the selected menu**, press **OK**.
- **To go back to the previous level** in the menu system, press **Exit**.
- **To exit the menu system completely** from anywhere in the menu system, press **2nd** **Exit**.
- **To reach a specific item** in the menu system, press **2nd** **Menu** and a number corresponding to the entry level.

Example: Press **2nd** **Menu** **5** to access the 'Logon' menu (which is the 5th entry in the main menu).

Restricted access

There are 4 different levels of access to the menus:

- **Users without a PIN code.**
If the handset is locked with the Normal User PIN code, the only function available is answering the phone. If the Normal User PIN code is disabled, all Normal User functions are available.
- **Normal User**
The Normal User has access to normal everyday functions and to make changes to these.
- **Super User**
The Super User has the same rights as the Normal User, but can additionally access a few extra settings that are not available to the Normal User.
- **Service Provider**
The functions restricted by the Service Provider PIN code can only be accessed by the supplier or Cobham SATCOM.

You will be prompted for a PIN code when entering a function that is restricted by PIN codes. See more about setting PIN codes at *System Setup, Pin Setup* on page 136.

Use the SDU phone book

The **Phone Book** can contain up to 99 entries, which can be used for making phone calls. You can edit, delete or insert entries.

To access the **Phone Book** menu, you can:

- press **↑** *Edit* or **↓** *Mute* from the main display, or
- press **OK** to enter the main menu, scroll to **Phone Book** and press **OK**.

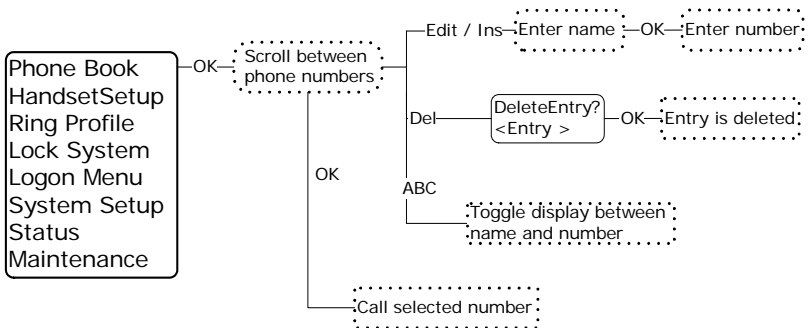

Each entry holds the following information:

- Name
- Telephone number

The telephone number must include call prefix for automatic calls and international access code. The telephone number can hold up to 22 digits.





The name can hold up to 24 characters.

The list of entries in the phone book is sorted alphabetically.



An entry in the phone book is displayed as a name if in alpha mode or as a telephone number if in normal mode. Note that only the first 12 digits are displayed.

To make a call using the phone book

Do as Follows:





1. Within the phone book, use   to select an entry.
2. Press ,  or  to dial.

Hint: You may also go directly to a specific entry by pressing the key holding the first letter of the entry.

Example: To find an entry with the name Jones, press  once. To find an entry with the name Larsen, press  three times.

To insert a new entry in the phone book



Do as follows:

1. From within the phone book, press  .
2. Enter the name of the new entry followed by .
3. Enter the phone number including country code and press .

Example: In this example the number to Cobham SATCOM VA, 00 1 757 463 9557, is inserted:

 
THRANE 
00 1 757 463 9557 

To delete an entry in the phone book

1. Select the entry in the phone book.
2. Press  .

To edit an entry in the phone book

Do as follows:

1. Select the entry in the phone book.

2. Press **[2nd]** **[↑Edit]** and type in the new name followed by **[OK]**. Then type in the new number followed by **[OK]**.

Handset Setup

Overview

The **HandsetSetup** menu is used for adjusting the light and sound settings of the handset.

The **HandsetSetup** menu has the following submenus:

- Silent
- Contrast
- Light
- Key Beep
- Single Ring
- Common Ring
- Ring Volume
- Phone Volume
- ComfortNoise

Each of the submenus is described in the following pages.

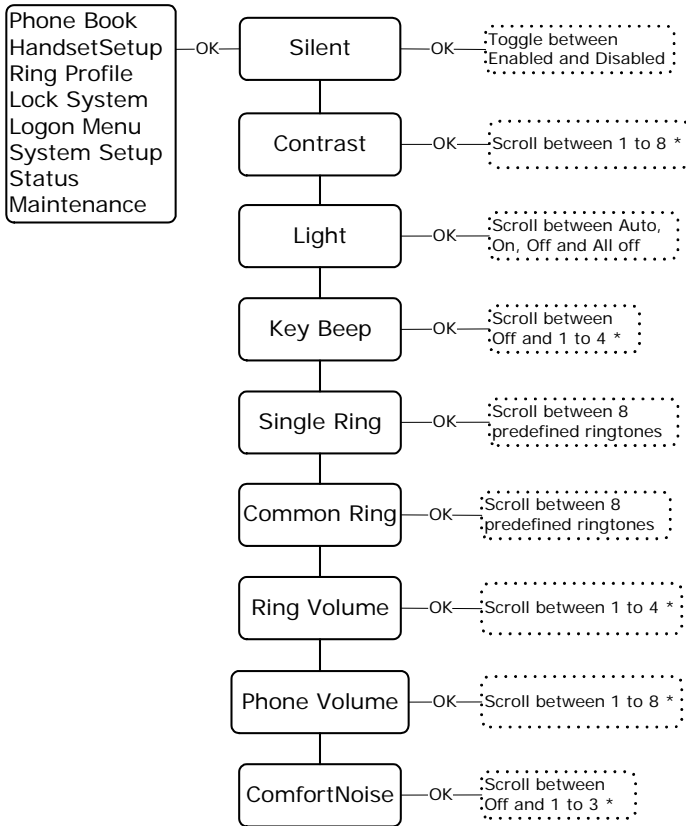

The Handset Setup menu

To access the HandsetSetup menu, enter the main menu, scroll down to **HandsetSetup** and press **OK**.





To enable/disable the Silent function

Select **Silent** to view or change the Silent setting of the handset.

Use  **Edit** and  **Mute** to toggle between **Enabled** and **Disabled**.
Enabled turns off the ring tone of the handset.

To adjust the LCD contrast



Select **Contrast** to view or change the contrast setting of the handset display.

Use  **Edit** and  **Mute** to adjust the contrast and  to confirm.

The value can be between * and *****.

To change the light settings

Select **Light** to view or change the light settings of the handsets.

Use  **Edit** and  **Mute** to scroll between the settings and  to confirm.

The value can be **Auto** | **On** | **Off** | **All Off**.



The following table shows the function of the light settings.

Setting	Display Backlight	LEDs
Auto	Activated on event	Normal function
On	Always on	Normal function
Off	Always off	Normal function
All Off	Always off	Always off

To adjust the key beep volume

Key beep is a “beep” sound when a key is pressed.

Select **Key Beep** to view or change the key beep setting of the handsets.



Use  **Edit** and  **Mute** to adjust the volume of the key beep and  to confirm.

The value can be **Off** or between ***** and ********.

To select the ring tone for a direct call

Single Ring is the ring tone for a direct call (opposite to a broadcast call).

Select **Single Ring** to view or change the direct ring tone setting of the current handset.



Use  **Edit** and  to scroll through the ring tones and  to select.

You can choose between 8 predefined ring tones.

To select the ring tone for broadcast calls

Common Ring is the ring tone for broadcast calls.



Select **Common Ring** to view or change the broadcast ring tone setting of the current handset.

Use  **Edit** and  to scroll through the ring tones and  to select.

You can choose between 8 predefined ring tones.



To adjust the ring volume

Select **Ring Volume** to view or change the Ring Volume setting of the handset.

Use  and  to adjust the Ring Volume and  to confirm.
The value can be between * and ****.

To adjust the phone volume



Select **Phone Volume** to view or change the initial volume setting for the handset. To adjust the volume during a call, use the volume control on the side of the handset.

Use  and  to adjust the Phone Volume and  to confirm.
The value can be between * and *****.

To adjust the Comfort Noise

Comfort Noise is a background noise to verify that the line is connected.

Select **ComfortNoise** to view or change the Comfort Noise setting of the handset.

Use  and  to adjust the Comfort Noise and  to confirm.
The value can be Off or between * and ***.

Ring Profile

Overview

The **Ring Profile** menu allows you to select from a list of ring profiles. A ring profile applies to the entire system and determines the ring settings of each unit in the system.

To select a Ring Profile

Do as follows:

1. To access the **Ring Profile** menu, enter the main menu, scroll down to **Ring Profile** and press **OK**.
2. Use **↑^{Edit}** and **↓^{Mute}** to scroll through the ring profiles and **OK** to select.

Note

If the “Chime/Lamps Inhibit” function is used in the installation, the “TakeOfLandng” profile is automatically activated during takeoff and landing.

For information on how to change the ring profiles, see the section *System Setup, Ring Profiles* on page 133.

Lock System

Overview

The **Lock system** menu can be used to lock the phone. When the phone is locked, you can still answer an incoming call, but you cannot access any of the functions until you press **OK** and enter the Normal User PIN code.

To lock the handset

Do as follows:

- To lock the phone, enter the main menu, scroll down to **Lock system**, press **OK** and enter the Normal User PIN code.
- To unlock the phone, press **OK** and enter the Normal User PIN code.

Logon Menu

The **Logon Menu** is used to log on or off the system, or to change the Logon settings.

The Logon Menu has the following sub menus:

- Manual Logon
- Custom Logon
- Auto Logon
- Logoff
- Settings (see *Logon menu settings* on page 126)

To access the Logon Menu, enter the main menu, scroll down to **Logon Menu** and press **OK**.

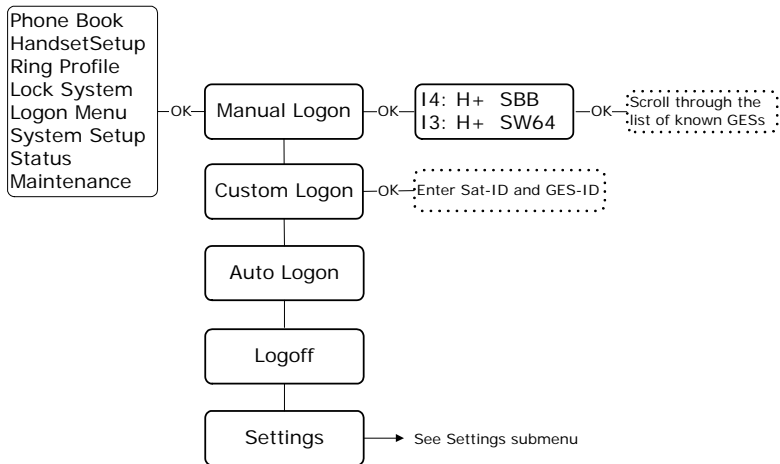

To log on manually

Note Before logging on manually, make sure the Logon Policy is set to Manual. To change the Logon Policy, select Settings from the Logon Menu and then Logon Policy. You can toggle between Manual and Automatic and select with **OK**.

Select the satellite and the services

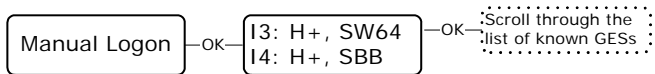

- I4 satellite offers the services Classic Aero (H⁺) and SwiftBroadband (SBB)
- I3 satellite offers the services Classic Aero (H⁺) and Swift64 (SW64/HSD) services.

Note In most cases the I4 satellite is used.

1. Select **Manual Logon** to select the satellite type you want to logon to: I3 or I4. Use **↑Edit** and **↓Mute** to scroll through the list and **OK** to select.
2. Select the GES from the list of known GESs. Use **↑Edit** and **↓Mute** to scroll through the list and **OK** to select.

To make a custom logon

Note Before making a Custom Logon, make sure the Logon Policy is set to Manual. To change the Logon Policy, select Settings from the Logon Menu and then Logon Policy. You can toggle between Manual and Automatic and select with **OK**.

You can use this menu if you need to log on to a GES which is not in the list of known GESs.

1. Select **Custom Logon** to manually enter the Sat-ID and GES-ID you want to use for logging on.
For a list of supported GESs, see *List of available GESs* on page 215.
2. Enter the Sat-ID and GES-ID and press **OK** to confirm.

To select automatic logon

Select **Auto Logon** to log on automatically to the most appropriate GES.

To log off

Select **Logoff** to log off the system.
To log on again you have to use the logon menu.

Logon menu settings

From the **Settings** submenu you can change the logon policy and view or change the lists of preferred GESs and LESs.

The **Settings** menu has the following sub menus:

- Logon Policy
- Pref. H+GES
- Pref. ISDN LES
- Pref. MPDS LES

Each of the submenus is described in the following pages.

The Settings submenu

To access the **Settings** submenu, enter the **Logon Menu**, scroll down to **Settings** and press **OK**.

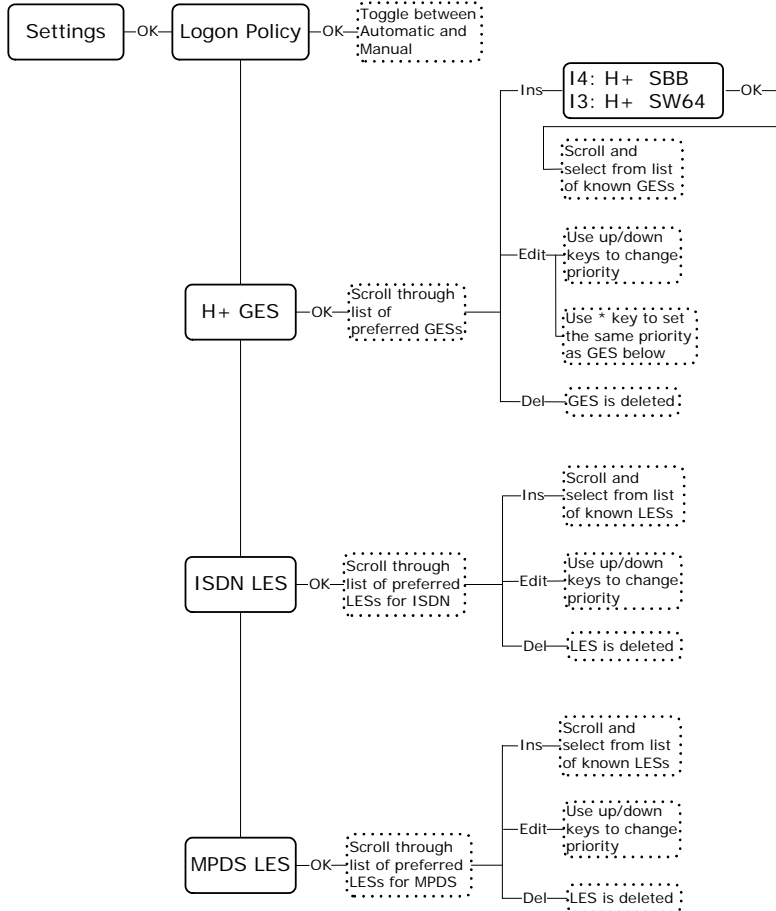

To select the Logon Policy

Select **Logon Policy** to display or change the logon policy.

Use  and  to toggle between **Automatic** and **Manual**.

- **Automatic**: The system automatically logs on when it is powered.
- **Manual**: When the system is powered, you have to enter the Logon menu to log on to the system.







To modify the list of Preferred GESs

Select **H⁺ GES** to view or change the list of preferred GESs for H⁺ transmission.

The H⁺ GES list is a list of the preferred GES operators to use as gateway to the terrestrial network.



Note | The list of preferred GESs is typically selected during system installation. If the GES list is empty, the system will automatically select the most suited satellite and a random GES.

Do as follows:

- To **add a GES** to the list, press , scroll through the list of known GESs and use  to select the GES you want to add.
- To **delete a GES** from the list, scroll to the GES you want to delete and press .
- To **change the priority** of a GES, scroll to the GES you want to change and press . Use  or  to move the GES to the right priority and press .

Note | Priority no. 1 is the highest priority!

- To **assign the same priority** to two GESs, scroll to the GES you want to change (GES 1) and press .

Using  or , move GES 1 next to the GES with the priority you want (GES 2), so that they are both visible in the display.

Then press . The two GESs should now both have the priority of GES 2.

To modify the list of Preferred ISDN LESs

Select **ISDN LES** to view or change the list of preferred LESs for ISDN transmission. The ISDN LES list is a list of the LES operators that are preferred as gateway for ISDN traffic to/from the terrestrial network.

Note | The list must include one LES as a minimum. One LES covers all ocean regions.

- To **add a LES** to the list, press **2nd** **C^{Ins}**, scroll through the list of known LESs and use **OK** to select the LES you want to add.
- To **delete a LES** from the list, scroll to the LES you want to delete and press **2nd** **ⓧ^{Del}**.
- To **change the priority** of a LES, scroll to the LES you want to change and press **2nd** **↑^{Edit}**.
Use **↑^{Edit}** or **↓^{Mute}** to move the LES to the right priority and press **OK**.

Note | Priority no. 1 is the highest priority!

To modify the list of Preferred MPDS LESs

Select **MPDS LES** to view or change the list of preferred LESs for MPDS transmission. The MPDS LES list is a list of the LES operators that are preferred as gateway for MPDS traffic to/from the terrestrial network.

Note | The list must include one LES as a minimum. One LES covers all ocean regions.

- To **add a LES** to the list, press **2nd** **C^{Ins}**, scroll through the list of known LESs and use **OK** to select the LES you want to add.
- To **delete a LES** from the list, scroll to the LES you want to delete and press **2nd** **ⓧ^{Del}**.
- To **change the priority** of a LES, scroll to the LES you want to change and press **2nd** **↑^{Edit}**. Then use **↑^{Edit}** or **↓^{Mute}** to move the LES to the right priority and press **OK**.

System Setup

The **System Setup** menu is used for viewing and changing system parameters such as ring profiles, PIN codes etc.

The System Setup menu has the following submenus:

- Ring Profiles (see *System Setup, Ring Profiles* on page 133)
- QuickDial (see *System Setup, Quick Dial* on page 135)
- Disclose Pos
- Fax Setup
- Pin Setup (see *System Setup, Pin Setup* on page 136)
- Configure (see *System Setup, Configure* on page 138)

Each of the submenus is described on the following pages.

The System Setup menu

To access the System Setup menu, enter the main menu, scroll down to **System Setup** and press **OK**.

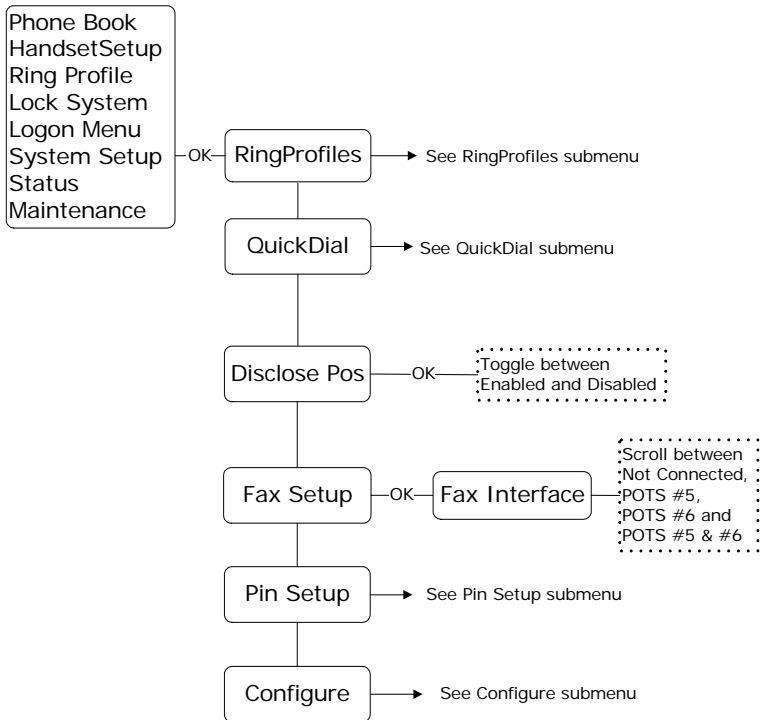

To enable/disable disclosure of the aircraft position



Select **Disclose Pos** to view or change the Disclose Position status.

Use  and  to toggle between **Enabled** and **Disabled**.

- If you select **Enabled**, the position of the aircraft will be disclosed to the earth station for use in the Inmarsat network.
- If you select **Disabled**, only the ID of the current spot beam is disclosed.

To turn off the broadcast ring tone for an interface

Select **Fax setup** to determine which interface should not ring on a broadcast call.

Use  and  to scroll through the interface options and select with .

You may select:

- POTS #5
- POTS #6
- POTS #5 & #6, or
- Not Connected

System Setup, Ring Profiles

The **RingProfiles** submenu is used to view or change the Ring Profiles of the system. A ring profile applies to the entire system and determines the ring settings of each unit in the system.

You can have up to 5 ring profiles. The name of one of the profiles, "TakeOfLandng", is predefined and cannot be changed.

Note If the "Chime/Lamps Inhibit" function is used in the installation, the "TakeOfLandng" profile is automatically activated during takeoff and landing.

To access the **RingProfiles** submenu, enter the **System Setup** menu, scroll down to **RingProfiles** and press **OK**.

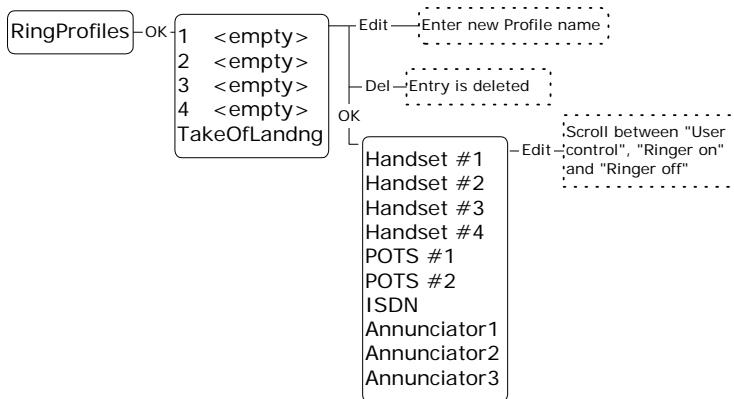

To change the name of a profile

Do as follows:

1. Scroll to the profile.
2. Press **2nd** **↑ Edit**.
3. Type in the new name and press **OK**.

To change the contents of a profile

Do as follows:

1. Select the profile using **OK**.
2. Scroll to the device you want to change the settings for, and select it with **OK**.
3. Use **↑ Edit** and **↓ Mute** to toggle between **User Control**, **Ringer On** and **Ringer Off**.

Note

“User Control” is only applicable to Handset #1 through #4. This means you can configure each of the handsets #1 through #4 separately. For the remaining devices, “User Control” has the same function as “Ringer On”.

To delete a profile

Do as follows:

1. Scroll to the profile you want to delete.
2. Press **2nd** **ⓧ Del**.

Explanation of the annunciators

- **Annunciator #1** (Call Annunciator): This Annunciator is used for signalling incoming voice calls. The Annunciator is “flashing” like the Connection LED on a Full Feature handset and is turned off when the call is answered or terminated by initiator.
- **Annunciator #2** (Fax Annunciator): This Annunciator is used for signalling incoming faxes. The Annunciator is “steady ON” until a receipt for the fax has been given in the handset.
- **Annunciator #3** (Service Annunciator): This Annunciator is used for indicating service availability. The Annunciator is “steady ON” when H⁺ service is available.

System Setup, Quick Dial

Overview

The **QuickDial** submenu is a list of 1-digit numbers for quick dialling of up to 9 favorite phone numbers.

To access the **QuickDial** submenu, enter the **System Setup** menu, scroll down to **QuickDial** and press **OK**.

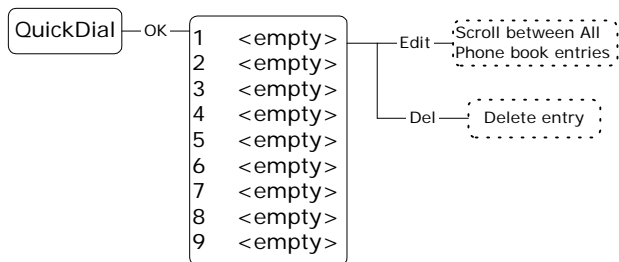

To delete a Quick Dial entry

Do as follows:

1. Scroll to the quick dial number you want to delete.
2. Press **2nd** **Del**.

To edit a Quick Dial entry

Do as follows:

1. Scroll to the quick dial number you want to change and press **2nd** **↑Edit**.
2. Scroll through the phone book to the phone number you want to use with the selected quick dial number.
3. Press **OK** to select the phone number.

System Setup, Pin Setup

PIN codes for the full-feature handset

For some of the functionality, access to the full-feature handset is restricted by a PIN code. Three different kinds of user PIN codes are used in the satcom system:

PIN code	Functionality
Normal User	The normal everyday user can make and receive calls, access the phone book, choose an ocean region and a default LES and GES, and read the error log and status.
Super User	The Super User has the same rights as the Normal User. In addition, the Super User can access certain super user functions. A Super User will typically be a person responsible for setting up and maintaining the system.
Service Provider	The Service Provider has access to all functionality accessible through the Full Feature handset. Only Cobham SATCOM and/or the supplier of the equipment normally know this PIN code.

For all PIN code types the length must be between 4 and 8 digits. For further information how to change and disable PIN codes see *System Setup, Pin Setup* on page 136.

Use the **Pin Setup** submenu to disable or change PIN codes.

To access the **Pin Setup** submenu, enter the **System Setup** menu, scroll down to **Pin Setup** and press **OK**.

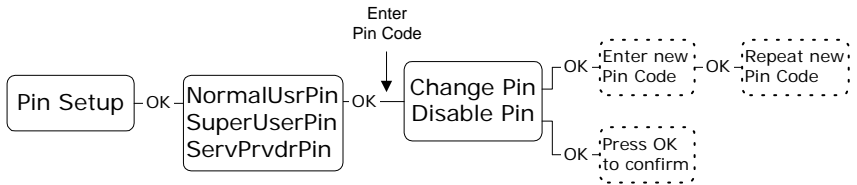

To access the PIN codes

To access the PIN codes you want to change or disable, do as follows:

1. Scroll to the PIN code type you want to change or disable.
2. Enter the current PIN code for the selected type.

Note

The Super User PIN code can also be used where Normal User PIN code is required.

3. Toggle between **Change Pin** and **Disable Pin** and use **OK** to select the function.
 - **Change Pin:** Choosing **Change Pin** you will be prompted for a new PIN code. Enter a new PIN code of 4 to 8 digits and use **OK** to accept the code. When you are prompted to re-enter the PIN code, enter the code again and accept with **OK**.
 - **Disable Pin:** Select **Disable Pin** to disable the PIN code you entered. Press **OK** to confirm the deletion. When you disable a PIN code, the functions that were previously restricted by the selected PIN code will now be freely available.

System Setup, Configure

Overview

The **Configure** submenu is used for configuring the handset type and the lists of known GESs, LESs and satellites.

For complete configuration of the system, use the Aero-SDU Configuration Program.

Note

A Service Provider PIN code is required to access the settings in the Configure menu.

The Configure menu has the following submenus:

- Handset Type
- Known GESs
- Known LESs
- Init Sat

Each of the submenus is described in the following pages.

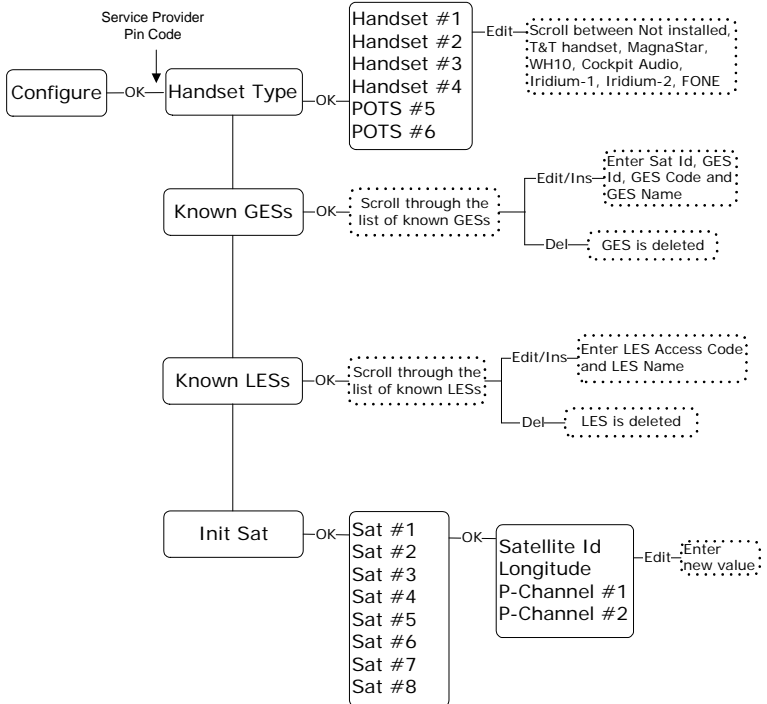

The Configure submenu

To access the **Configure** submenu, enter the **System Setup** menu, scroll down to **Configure** and press **OK**.







To select the handset type

Select **Handset Type** to view or change the type of the handsets.

Use  and  to scroll through the list of handsets.







To **change the handset type**, do as follows:

1. Select the handset you want to change.
2. Press  .
3. Use  and  to scroll between the selections available.
4. Press  to select.



To modify the list of Known GESs

Select **Known GESs** to view or change the list of known GESs.

To **add a GES** to the list, do as follows:

1. Press  .
2. Type in:
 - Satellite ID, followed by 
 - GES ID, followed by 
 - GES Code, followed by 
 - GES Name, followed by 

To **delete a GES** from the list, do as follows:

1. Scroll to the GES you want to delete.
2. Press  .

To **edit a GES**, do as follows:

1. Scroll to the GES you want to change.
2. Press **2nd** **↑^{Edit}**.
3. Type in:
 - Satellite ID, followed by **OK**
 - GES ID, followed by **OK**
 - GES Code, followed by **OK**
 - GES Name, followed by **OK**

To modify the list of Known LESs

Select **Known LESs** to view or change the list of known LESs.

To **add a LES** to the list, do as follows:

1. Press **2nd** **C^{Ins}**.
2. Type in:
 - LES Access (the Global LES Access Code), followed by **OK**
 - LES Name, followed by **OK**

To **delete a LES** from the list, do as follows:

1. Scroll to the LES you want to delete.
2. Press **2nd** **ⓧ^{Del}**.

To **edit the LES information**, do as follows:

1. scroll to the LES you want to change.
2. Press **2nd** **↑ Edit**.
3. Type in:
LES Access (the Global LES Access Code), followed by **OK**
LES Name, followed by **OK**

To change the initial satellite information

Select **Init Sat** to view or change the list of satellites.

To **delete a satellite** from the list, do as follows:

1. Scroll to the satellite you want to delete.
2. Press **2nd** **⏏ Del**.

To **edit the satellite information**, do as follows:

1. Scroll to the satellite you want to change
2. Press **OK**.
3. Type in:
Satellite ID, followed by **OK**
Longitude, followed by **OK**
The number for P-Channel #1, followed by **OK**
The number for P-Channel #2, followed by **OK**

Status

The **status** submenu is used for viewing signal strength, LAN status, navigation data, active errors, serial numbers and software versions.

The Status menu has the following submenus:

- Logon Status
- Channels
- Nav Data
- IDs
- SW version
- LAN
- Active Errors
- Error Log

Each of the submenus is described in the following pages.

The Status menu

To access the **Status** menu, enter the main menu, scroll down to **Status** and press **OK**.

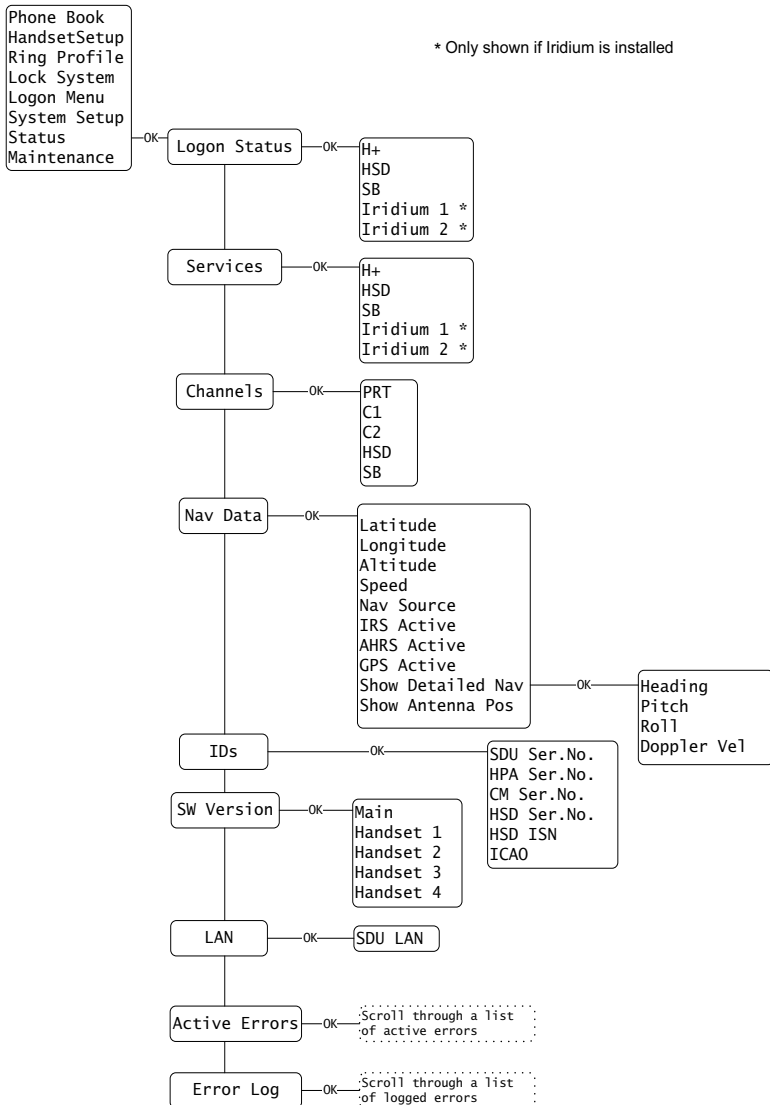

To view the logon status

Select **Logon Status** to display the logon status of:

- the H⁺ channel (Classic Aero)
- the HSD channel (Swift64)
- the SBU channel (SwiftBroadband)
- Iridium 1 (if installed)
- Iridium 2 (if installed)

Use  and  to select among the channels.

To view the status of services

Select **Services** to display the availability of:

- the H⁺ service (Classic Aero)
- the HSD service (Swift64)
- the SBU service (SwiftBroadband)
- Iridium 1 (if installed)
- Iridium 2 (if installed)

Use  and  to select among the services.

To view the signal strength of the channels

Select **Channels** to display the signal strength (C/No in dBHz) of:

- PRT (P-channel)
- C1 (H⁺ voice channel) (Classic Aero)
- C2 (H⁺ voice channel) (Classic Aero)
- HSD (Swift64 channel)
- SBU (SwiftBroadband channel)

Use  and  to select among the channels.

Note

For the channels to work properly, the value of the signal strength should be above the values mentioned below:



- P-Channel: above 35 dBHz
- C-Channels: above 42 dBHz
- HSD-Channel (Swift64): above 40 dBHz (TDM ~ Global)
- HSD-Channel (Swift64): above 54 dBHz (ISDN/MPDS ~ Spot)
- SBU-Channel (SwiftBroadband): above 41 dBHz (Global)
- SBU-Channel (SwiftBroadband): above 48 dBHz (Regional)
- SBU-Channel (SwiftBroadband): above 58 dBHz (Narrow)

If no signal is present, the display shows N/A.

To view the navigation data

Select **Nav data** to display the navigation data:

- **Latitude** (in degrees, minutes, seconds)
- **Longitude** (in degrees, minutes, seconds)
- **Altitude** (in feet)
- **Speed** (ground speed in knots)
- **Nav source** – the source used for navigation; can be IRS or AHRS+GPS
- **IRS Active** – shows whether or not the IRS is active
- **AHRS Active** – shows whether or not the AHRS is active
- **GPS Active** – shows whether or not the GPS is active
- **Show Detailed Nav**
 - **Heading** – (0 to 360 degrees)
 - **Pitch** (in degrees U or D (up or down))
 - **Roll** (in degrees L or R (left or right))
 - **Doppler Velocity** - the speed of the aircraft relative to the satellite, given in knots.
- **Show Antenna Pos** – the position of the antenna in degrees relative to the attitude of the aircraft, given as the Azimuth (horizontal position) and the Elevation (vertical position).

Use  **Edit** and  **Mute** to select among the Navigation parameters.

To enter the **Show Detailed Nav** menu, scroll to **Show Detailed Nav** and press **OK**.

To view serial numbers and ICAO address

Select **ID** to display:

- SDU Ser. No. (Serial number of the Satellite Data Unit)
- HPA Ser. No. (Serial number of the High Power Amplifier)
- CM Ser. No. (Serial number of the Configuration Module)
- HSD Ser. No. (Serial number of the HSD board)
- HSD ISN (Inmarsat Serial number of the HSD channel (Swift64))
- ICAO (ICAO Address)

Use **↑^{Edit}** and **↓^{Mute}** to scroll through the numbers.

The serial number of the SBU can be found in the SBU web interface, see *Use the Dashboard* on page 170.

To view the software version

Select **SW version** to display the version number and certification level of:

- Main software
- Handset 1 firmware
- Handset 2 firmware
- Handset 3 firmware
- Handset 4 firmware

Use **↑^{Edit}** and **↓^{Mute}** to scroll through the types of software.

To view the LAN status



Select **LAN** to view the status of the network. You may view:

- SDU LAN (the status of the LAN connected to the SDU)

The status can be “connected” or “disconnected”.



To view active errors



Select **Active errors** to display information of any active errors.

If there is more than one error, use  and  to scroll through the error list.

To view the error log

Select **Error Log** to display a list of sessions. For each session is indicated if there were errors (the display reads e.g. 2 items below the session number) or if there were no errors (the display reads Empty).

Use  and  to scroll through the list of sessions.



To see details for a session, press . Use  and  to scroll through the details.

For each session, the display shows the start time, the Build ID and the end time of the session. If there are errors, the display also lists the error text and the error code for each error.

Maintenance (reset)

You can initiate a reset of the system.

Select **Maintenance** and press  again.

Use  to select Yes, then press  to reset the system.

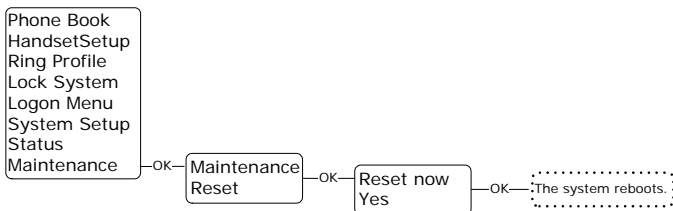

MCDU operation

This section describes how to access the menu system using the keys and display of the MCDU.

- *Operate the MCDU*
- *AVIATOR 700 main menu*
- *SUBMENU*
- *LOCK menu*
- *SYSTEM menu*
- *LOGON menu*
- *STATUS menu*

Operate the MCDU

The MCDU is used to control and operate the SATCOM equipment from the cockpit. A subset of the MCDU menus and functions are identical to those of the Full Feature handsets. The following sections describe the AVIATOR 700 menu functions of the MCDU and explain how to navigate the MCDU.

Note

This chapter only describes the part of the MCDU functions that concerns the AVIATOR 700 system. For information on other functions in the MCDU, refer to the documentation delivered with your MCDU and, if relevant, with any other connected equipment.

See also *To enter the SATCOM subsystem* on page 86.

AVIATOR 700 main menu

AVIATOR 700 (logged on)

The AVIATOR 700 main menu is shown when initially accessing the AVIATOR 700 subsystem. The content of the **SATCOM MAIN** menu depends on the logon status and the presence of errors. Upon successful logon, the MCDU display shows:

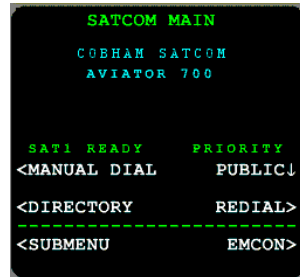

- **MANUAL DIAL** presents an extended set of features for dialing. For more information about **MANUAL DIAL**, see *Make or receive a phone call (MCDU)* on page 87.
- **DIRECTORY** gives access to the user-defined directory of phone numbers.
- **SUBMENU** gives access to system configuration, status and other information. For detailed information on this menu see the following section.
- **PRIORITY** configures the Classic Aero (H⁺) call priority of outgoing calls. This is visible only if logged on. For further information on call priorities see *To make a call (air to ground) (MCDU)* on page 88. The possible values are: PUBLIC, NON-SAFETY, SAFETY and EMERGENCY
- **REDIAL** lists the 10 most recent calls made. Press the ► or ◀ key next to a number to activate a call.
- **EMCON** (Emission Control): This option will preempt all active calls, log off satcom and establish radio silence. This is visible only if configured in the Aero-SDU Configuration Program.

AVIATOR 700 main menu (logged off)

If the system is not logged on, the **SATCOM MAIN** menu looks as shown in the image to the right.

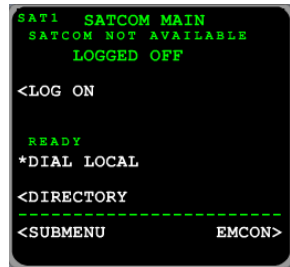

- **LOG ON** allows you to log on the system and to change the logon settings.
- **DIAL LOCAL** activates a call to a local phone. Use the numerical keys on the keypad to dial the number of the local phone directly from the main menu.
- **DIRECTORY** gives access to the user-defined directory of phone numbers.
- **SUBMENU** gives access to system configuration, status and other information. For detailed information on this menu see the following section.
- **EMCON** (Emission Control): This option will preempt all active calls, log off satcom and establish radio silence. This is visible only if configured in the Aero-SDU Configuration Program.

SUBMENU

The **SUBMENU** view contains the following menu items:

- **LOCK** allows you to lock the keypads of all handsets connected to the SDU.
- **LOGON** allows you to log on or off the system, and to change the logon settings.
- **SYSTEM** allows you to view or change system parameters such as ring profiles, PIN codes, handsets and known GESs, LESs and satellites.
- **STATUS** contains system status such as logon status, navigational data, software and hardware versions, active errors and error log.

The **SUBMENU** view contains the following selection item:

- **RINGPROFILE** allows you to select the currently active ring profile from a list that can be configured. The ring profile is applied

immediately to all handsets connected to the SDU. For more information on the predefined profile **TAKEOFF/LANDING** see *RING PROFILES* on page 156.

For an overview over the menus of the MCDU see *Menu tree for the MCDU* on page 213.

LOCK menu

The SDU can be locked so that new calls can not be initiated with handsets connected to the SDU. Locking the system will also block the user interface on all Full Feature Handsets and MCDUs. Note that a Normal User PIN code must be defined before you can use this feature.

Important

The lock function applies only to the SDU and handsets connected to the SDU. It does not prevent users from initiating calls and start new data sessions from devices connected to the SBU while the SDU is locked.

To lock all handsets connected to the SDU and all MCDUs, do as follows:

1. Enter the **LOCK** view.
2. Type in the Normal User PIN code.
3. Select button next to PIN code.
4. All SDU user interfaces are now locked.

Note

If power cycling the system while it is locked, it will stay locked after power up.

5. To unlock the SDU type in the Normal User PIN code and select the button next to the PIN code. All user interfaces will be unlocked.

Note

You can unlock a single Full Feature Handset by typing in the Normal user PIN code in that handset and pressing **OK**.

If you have forgotten the PIN code, contact your aircraft installation and service center or your local distributor.

LOGON menu

The logon policy of the system can be configured for either automatic or manual logon. In automatic mode, the AVIATOR 700 system automatically logs on to a satellite. For manual logon, the crew can explicitly select the satellite and GES for log on and hand over, and initiate hand overs at any time. Typically, the logon policy is set to automatic mode.

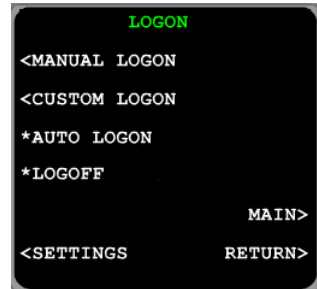

The **LOGON** view contains the following menu items:

- **MANUAL LOGON** allows to select a specific GES for logon from a predefined list of all known GESs. This is visible only in manual mode.
- **CUSTOM LOGON** allows to select any satellite and GES identifiers for logon. This is visible only in manual mode.
- **SETTINGS** allows to change the logon policy and modify the list of preferred GESs and LESs.

The **LOGON** view contains the following functions:

- **AUTO LOGON**: Select this function to initiate the logon procedure toward the most appropriate satellite and GESs while taking the list of preferred GESs into account.
- **LOGOFF** logs off the system. Both in manual and automatic mode, the user must take action to logon the system again.

MANUAL LOGON

This view presents a list of all known GESs. For each GES the following information is shown:

- Name of the GES.
- Satellite on which the GES operates.
- Identifier of the GES.
- Services supported by the GES.

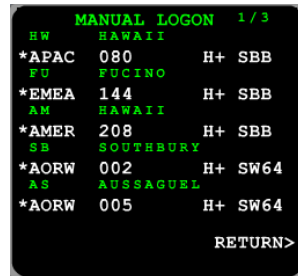

To logon to a specific GES, press the arrow key next to the row of the GES. The list may span several pages. To browse to the next page, press the button NEXT.

The right hand side of the view shows the services of the GES.

Example: If you select the GES **AMER 208** you will get the services H+ (Classic Aero) and SBB (SwiftBroadband). If you select the GES **AORW 002** you will get the services H+ (Classic Aero) and SW64 (Swift64).

CUSTOM LOGON

To initiate logon on a specific satellite and GES do as follows:

1. Enter the **CUSTOM LOGON** view.
2. Select a satellite.
3. Type in the identifier of the intended GES on the scratch pad. You find the GES ID in *List of available GESs* on page 215.
4. Press the arrow key next to the GES identifier and select **OK**.

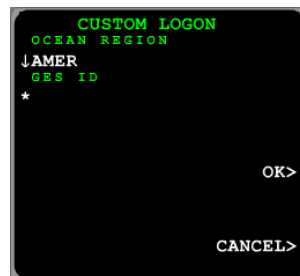

SETTINGS

The **SETTINGS** view contains the following items:

- **LOGON POLICY** indicates the current logon policy. The available options are:
 - **AUTOMATIC**
 - **MANUAL**

Changing this setting takes effect immediately, but does not trigger a log on or log off. Hence, if the system is not logged on and the logon policy is changed from manual to automatic, the user must enter the **LOGON** view and select **AUTO LOGON** to logon the system.

- **Pref. H+ GES** allows configuration of the user preferred GESs. This view lists the user prioritized GESs. The order and prioritization defines which GES the system will attempt logon with logon policy automatic. This list is typically configured during installation.

Note

Entries in this list must be in the list of Known GES. For further information see *CONFIGURE* on page 158.

- **PREF. ISDN LES** allows configuration of the user preferred LESs for ISDN use. This view lists the user prioritized LESs for ISDN usage. The order and prioritization defines which LES the system will use for ISDN when the system is logged onto an I3 satellite. This list is typically configured during installation.

Note

Entries in this list must be in the list of Known LES. For further information see *CONFIGURE* on page 158.

- **PREF. MPDS LES** allows configuration of the user preferred LESs for MPDS use. This view lists the user prioritized LESs for MPDS usage. The order and prioritization defines which LES the system will use for MPDS when the system is logged onto an I3 satellite. This list is typically configured during installation.

Note

Entries in this list must be in the list of Known LES. For further information see *CONFIGURE* on page 158.

The preferred GESs and LESs are typically configured during installation.

SYSTEM menu

The **SYSTEM** view contains the following menu items:

- **RINGPROFILES**
- **MODIFY PIN**
- **CONFIGURE**
- **TECHNICAL**
- **RESET**

RING PROFILES

In this view you can configure up to 5 different ring profiles **PROFILE1** to **PROFILE4** and **PROFILE5** <**TAKEOFLANDING**. Select a profile to view or edit it. A ring profile applies to the SDU of the AVIATOR 700 system and determines the ring setting (on/off) of each handset, ISDN and annunciator interfaces connected to the SDU. The profile name **TAKEOFLANDING** is predefined. If the function *Chime/Lamps Inhibit* is used in the installation, this profile is automatically activated during takeoff and landing.

The **PROFILE** view contains ring setting for each of the following devices connected to the SDU:

- **HANDSET #1**
- **HANDSET #2**
- **HANDSET #3**
- **HANDSET #4**
- **POTS #5**
- **POTS #6**
- **ISDN**
- **ANNUNCIATOR 1**
- **ANNUNCIATOR 2**
- **ANNUNCIATOR 3**

Each device can be set to **RINGER OFF** or **RINGER ON**.

To assign a name to a ring profile, do as follows:

1. Type in the name on the scratch pad.
2. Press the arrow key next to **NAME**.

To delete a ring profile, do as follows:

1. Enter the **RINGPROFILES** view.
2. Select a profile with the arrow key next to the profile.
3. Press the **CLR** key on the MCDU.
4. Press the arrow key next to **NAME**.
5. Select **OK**.

MODIFY PIN

The **MODIFY PIN** view lists the three PIN types and their current status (enabled or disabled):

- **Normal** User PIN. This PIN code is used for the **LOCK** function, see also *LOCK menu* on page 152.
- **Super** User PIN
- **Service** Provider PIN

For more information on PIN codes see *Restricted access* on page 114.

To enable a PIN code, do as follows:

1. Enter the **MODIFY PIN** view.
2. Press the arrow button next to the PIN code to be changed.
3. Enter the PIN code.
4. Select **NEW PIN**.
5. Enter the PIN code a second time.
6. Select **RETYPE PIN**.
7. Select **OK**.

To modify a PIN code, do as follows:

1. Enter the **MODIFY PIN** view.
2. Press the arrow button next to the PIN code to be changed.
3. Enter the old PIN code.
4. Press the arrow button next to the PIN code.
5. Enter the new PIN code.
6. Select **NEW PIN**.
7. Enter the new PIN code a second time.
8. Select **RETYPE PIN**.
9. Select **OK**.

To disable a PIN code, do as follows:

1. Enter the **MODIFY PIN** view.
2. Press the arrow button next to the PIN code to be changed.
3. Enter the old PIN code.
4. Select **DISABLE PIN**.
5. Select **OK**.

CONFIGURE

The **CONFIGURE** view contains the following items:

- **HANDSET TYPE** allows you to see the types of handsets connected to the SDU. In this view you can see the configuration of the handsets connected to the SDU. This setting is typically configured during the installation of the system. For further information see the AVIATOR 700 Installation and Maintenance Manual.

- **AUDIO 1** can be used to configure the audio of the cockpit headset, if connected to the AVIATOR 700 system.

Note | These settings only affect the cockpit headsets when they are used by the AVIATOR 700 system.

- **MIC** configures the volume of the microphone
- **SPEAKER** configures the volume of the speaker
- **SIDETONE** adjusts the sidetone percentage
- **SILENCE** enables (OFF) or suppresses (ON) ring tone
- **COMF. NOISE** configures the comfort noise
- **AUDIO 2** can be used to configure the audio of the cockpit headset, if connected to the AVIATOR 700 system. See **AUDIO 1**.
- **SATELLITE** allows configuration of the list of satellites and known GESs and LESs.

KNOWN GES — This list is used from other parts of the user interface, e.g. when making a manual logon (see *MANUAL LOGON* on page 154). The list of preferred GES' is a subset of the list of known GES'.

Note | This list is typically created during installation.

KNOWN LES — This list contains the LESs for which the lists of preferred LES' can be constructed.

Note | This list is typically created during installation.

INIT SAT — The first time the AVIATOR 700 system logs onto a satellite it locates the satellite based on the information associated with the satellites listed in this view.

Note | This table is created at the factory and typically should not be modified.

- **DISCLOSE POS** indicates whether the position of the system is disclosed to the GESs and LESs. This setting is typically configured during the installation of the system. For further information see the AVIATOR 700 Installation and Maintenance Manual.
- **FAX** configures the connection of fax to the POTS interfaces #5 and #6. This setting can be used to prevent ringing on the POTS interfaces during a broadcast call in case a fax has been connected. This setting is

typically configured during the installation of the system. For further information see the AVIATOR 700 Installation and Maintenance Manual.

TECHNICAL

TECHNICAL is for internal use only.

RESET

To reset (i.e. power cycle) the AVIATOR 700 system including the SBU, do as follows:

1. Enter **RESET** view.
2. Select **ACCEPT**.

This operation will restart the satcom. The operation will take several minutes.

STATUS menu

In the menus listed in the STATUS view you can find a large set of AVIATOR 700 status information:

- **LOGON** shows which services are logged on.
- **SERVICES** shows which services are ready for use.
- **CHANNELS** shows which channels are in use and their respective signal strength.
- **NAV DATA** shows detailed input from the external navigational source.
- **IDS** displays the serial numbers and ICAO address of the SDU.
- **SW VERSION** shows the software version and certification level of the SDU and connected Full Feature handsets.
- **LAN** shows the status of the SDU LAN connection.
- **ACTIVE ERRORS** lists the active essential errors.
- **ERROR LOG** contains logs from previous power cycles.

LOGON

This status is shown for the following services:

- **H+** (Classic Aero)
- **HSD** (Swift64)
- **SBU** (SwiftBroadband)
- **Iridium 1** (if installed)
- **Iridium 2** (if installed)

The logon status can take one of the values LOGGED ON or LOGGED OFF.

Note

The Classic Aero services are available on both I3 and I4 satellites, while data services using SwiftBroadband are available exclusively on I4 satellites. The AVIATOR 700 system uses Swift Broadband for data services whenever possible. Swift64 is used as a fallback solution for areas where SwiftBroadband is not available.

SERVICES

This view shows the availability of the following services:

- **H+** (Classic Aero)
- **HSD** (Swift64)
- **SBU** (SwiftBroadband)
- **Iridium 1** (if installed)
- **Iridium 2** (if installed)

The service status can be AVAILABLE or UNAVAILABLE.

Note

The Classic Aero services are available on both I3 and I4 satellites, while data services using SwiftBroadband are available exclusively on I4 satellites. The AVIATOR 700 system uses Swift Broadband for data services whenever possible. Swift64 is used as a fallback solution for areas where SwiftBroadband is not available.

CHANNELS

This view lists the signal to noise ratio (C/No in dB Hz) for each channel in the system. For further information see *To view the signal strength of the channels* on page 145.

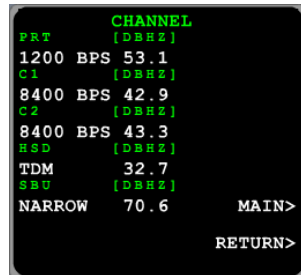

NAV DATA

This view shows information about the navigational input received from external systems:

- **LATITUDE** — in degrees, minutes, seconds.
- **LONGITUDE** — in degrees, minutes, seconds.
- **ALTITUDE** — in feet.
- **SPEED** — ground speed in knots.
- **NAV SOURCE** — the external source used for navigation which can be:
 - IRS or
 - AHRS+GPS

IRS shows the status of the IRS input. AHRS shows the status of the AHRS input. GPS shows the status of the GPS input.

The **NAV DATA** view contains the following menus:

- **DETAILED NAV**

This view shows the following detailed information:

- **HEADING** — 0 to 360 degrees.
- **PITCH** — in degrees (U = up; D = down).
- **ROLL** — in degrees (L = left; R = right).
- **DOPPLER VELOCITY**, — the speed of the aircraft relative to the satellite (knots).
- **ANTENNA POS**

This view shows the antenna pointing data. The pointing is relative to the attitude of the aircraft:

- **AZIMUTH** — horizontal position (degrees)
- **ELEVATION** — vertical position (degrees)

IDS

This view displays the serial numbers and IDs of the system units, including the ICAO address of the SDU.

You find identifiers related to the SBU (e.g. IMSI number and SBU serial number) on the dashboard of the SBU web interface. For further details see *Introduction to the SBU web interface, Properties* on page 171.

SW VERSION

This view displays the software version and certification level of the SDU (**MAIN**) and the firmware version of each connected Full Feature handset.

LAN

This view shows the status of the HSD (Swift64) LAN connection (SDU). It can be **CONNECTED** or **NOT CONNECTED**.

ACTIVE ERRORS

This view lists the active essential errors. For more information about a specific error see the AVIATOR 700 Installation and Maintenance Manual.

ERROR LOG

This view contains a list of logs. The first log is the current log. A new log is created upon each power cycle. Each log contains:

- Start time of the session (power cycle).
- End time of the session.
- Build ID (extended software version).
- Text and identifier for each error message (if any).

Use the SBU web interface

In the following sections you can read about:

- *Introduction to the SBU web interface*
- *Use the SBU phone book*
- *Use the Call log*
- *Start or stop any data session*
- *Call log handling*
- *Set data limits*
- *Set up the local exchange function*
- *Remote management and activation*
- *Remote activation of the SBU with SMS*
- *Restricted dialing*

Introduction to the SBU web interface

The web interface is built into the system and used for operating, setting up and configuring the system.

You can access the web interface from a computer with a standard Internet browser. The parts of the web interface that are used in daily use of the system are described in detail in the following paragraphs. The parts of the web interface that are used during system installation are described in detail in the AVIATOR 700 Installation and Maintenance Manual.

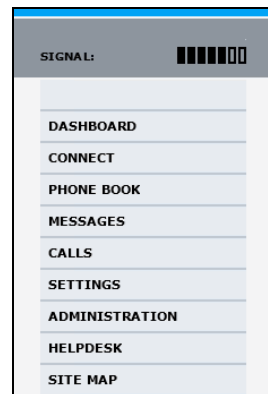

Connect to the web interface

To access the web interface, an Internet browser must be installed on the computer. Connect your computer to the AVIATOR 700 system, using one of the LAN interfaces (up to 6) installed in the aircraft cabin or use the Wireless connection, if available.

Proxy server settings

If you are connecting your computer using a LAN or WLAN interface, the **Proxy server** settings in your browser must be disabled before accessing the web interface. Most browsers support disabling of the Proxy server settings for one specific IP address, so you can disable Proxy server settings for the web interface only, if you wish. Consult your browser help for information.

To disable the use of a Proxy server completely, do as follows:

Note The following description is for **Microsoft Internet Explorer**. If you are using a different browser, the procedure may be different.

1. In Microsoft Internet Explorer, select **Tools > Internet Options > Connections > LAN Settings**.

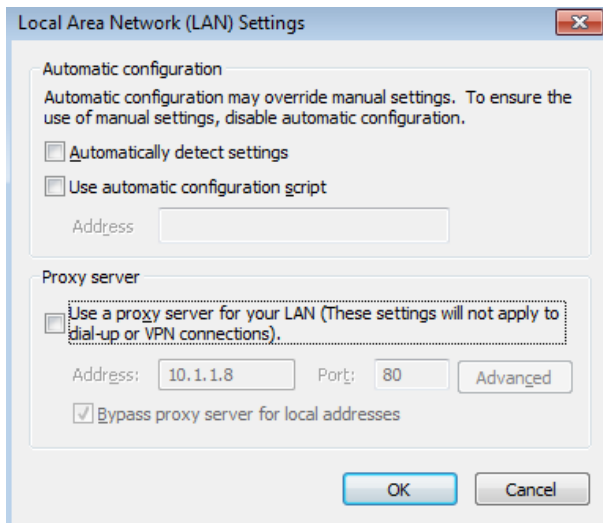

2. Clear the box labeled **Use a proxy server for your LAN**.
3. Click **OK**.

When the proxy server settings are disabled, close and restart your browser. You may need to change this setting back on return to your Internet connection.

IP address and DNS server address setup

To check whether automatic IP address and DNS server address is obtained automatically for your computer, do as follows (example for Windows 7):

1. Go to **Control Panel > Network and Internet > Network and Sharing Center**.
2. Click on the **LAN connection** you want to use.
3. Select **Properties**, highlight **Internet Protocol Version 4 (TCP/IPv4)**.
4. Click **Properties**.
5. Make sure that the following is selected:
 - Obtain an IP address automatically
 - Obtain DNS server address automatically

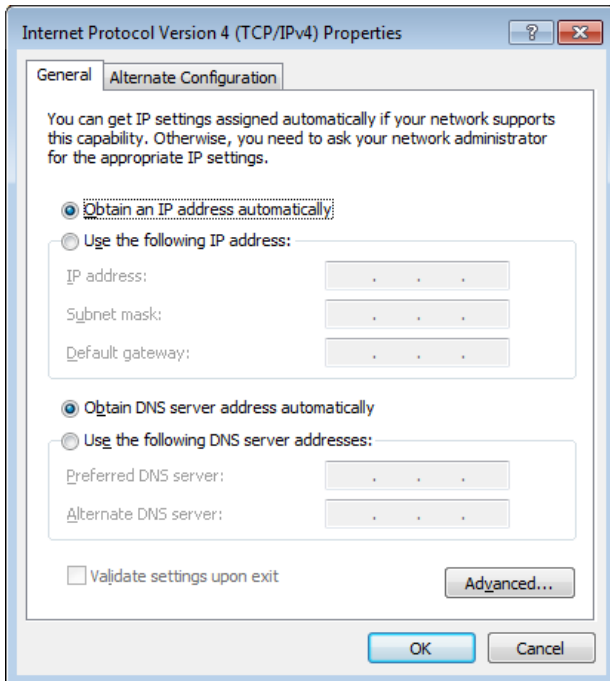

Allocating IP addresses and DNS server lookups are handled by the system.

Access the web interface

To access the web interface, do as follows:

1. Connect your computer to the system.
2. Make sure that the AVIATOR 700 system is fully operational in the aircraft.
3. Open your Internet browser and enter the IP address of the system. The default IP address is **http://192.168.0.1**. You can also type **http://ut.bgan** if your system use automatic assignment of IP to devices on the network (DHCP).

If your system uses a different IP address, you can look it up by connecting an IP handset and entering the BGAN menu. Select **Status > Properties > Local IP address**.

Note

If the IP address has been changed and you do not have the new address, contact your system administrator and request the new IP address.

Overview of the web interface

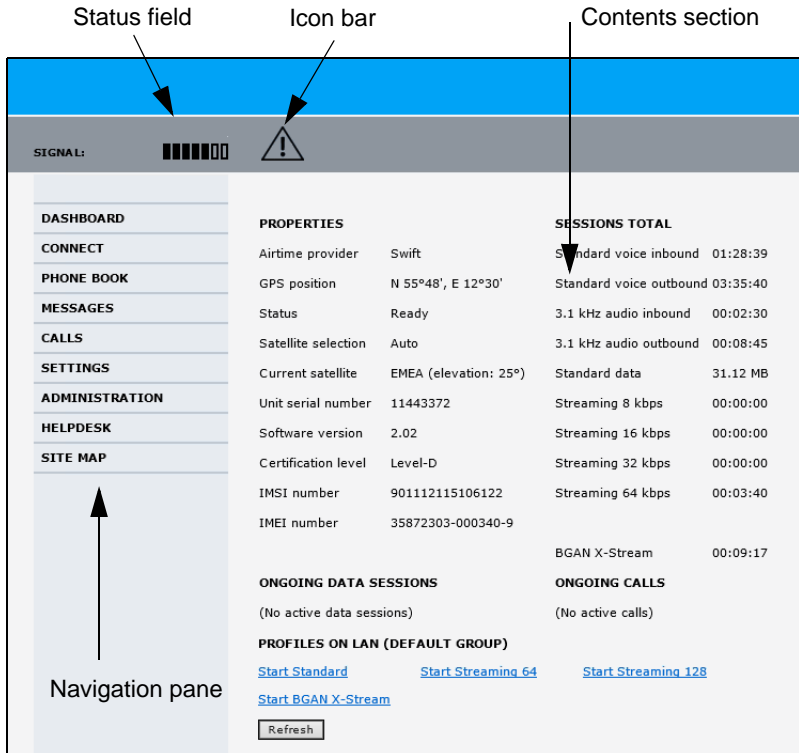

The web interface consists of the following sections:



- The **navigation pane** holds the main menu. Clicking an item in the menu opens a submenu in the navigation pane or a new page in the contents section.
- The **status field** shows the signal strength.
- The **icon bar** shows icons for new SMS messages and for active events, when relevant. For explanations of the icons, see the next section, *Icons in the icon bar*.
- The **contents section** shows the page selected in the navigation pane. This section is used to view or change settings, or for performing actions.

Icons in the icon bar

The following icons may appear in the icon bar in the web interface:

Icon	Explanation
	<p>A new SMS message, or information of Voice mail, has arrived. Click the icon to see new messages or information of Voice mail. For further information, see <i>To receive a message</i> on page 97.</p>
	<p>An event is active. Click the icon to see a list of active events. For explanations of the event messages, see the AVIATOR 700 Installation and maintenance manual. Note that this icon will remain in the icon bar as long as the event is still active.</p>

Navigate the web interface

- **To expand a menu**, click the menu in the navigation pane.
- **To access status and settings**, click the relevant subject in the navigation pane or click the relevant icon in the icon bar. The status or settings are displayed in the contents section.
- **To get an overview over the submenus available use the site map**, click **SITE MAP** in the navigation pane. Click on items in the site map to go directly to the relevant location.

Note

Some parts of the web interface may be greyed out if the user permissions are limited. For information on how to set up user permissions, see the AVIATOR 700 Installation and maintenance manual.

Use the Dashboard

The Dashboard is the first screen that is displayed when you enter the IP address of the web interface of the AVIATOR 700 system. The Dashboard is used for control and inspection of ongoing communication and for viewing properties and status of the system and antenna.

The dashboard interface includes a signal strength indicator and a warning icon. A navigation menu on the left lists: DASHBOARD, CONNECT, PHONE BOOK, MESSAGES, CALLS, SETTINGS, ADMINISTRATION, HELPDESK, and SITE MAP. The main content area is divided into three columns: PROPERTIES, SESSIONS TOTAL, and ONGOING DATA SESSIONS/ONGOING CALLS. At the bottom, there are links for starting different data sessions and a Refresh button.

PROPERTIES	SESSIONS TOTAL
Airtime provider: Swift	Standard voice inbound: 01:28:39
GPS position: N 55°48', E 12°30'	Standard voice outbound: 03:35:40
Status: Ready	3.1 kHz audio inbound: 00:02:30
Satellite selection: Auto	3.1 kHz audio outbound: 00:08:45
Current satellite: EMEA (elevation: 25°)	Standard data: 31.12 MB
Unit serial number: 11443372	Streaming 8 kbps: 00:00:00
Software version: 2.02	Streaming 16 kbps: 00:00:00
Certification level: Level-D	Streaming 32 kbps: 00:00:00
IMSI number: 901112115106122	Streaming 64 kbps: 00:03:40
IMEI number: 35872303-000340-9	BGAN X-Stream: 00:09:17

ONGOING DATA SESSIONS
(No active data sessions)

ONGOING CALLS
(No active calls)

PROFILES ON LAN (DEFAULT GROUP)

[Start Standard](#)
 [Start Streaming 64](#)
 [Start Streaming 128](#)
[Start BGAN X-Stream](#)

Properties

The **PROPERTIES** section of the **DASHBOARD** shows the following information:

- **Airtime provider.** The name of your Airtime Provider.
- **GPS position.** The GPS position of your AVIATOR 700 system.

Note

In some cases, the BGAN network does not allow the position to be displayed to the user. If this is the case, the display may just show **GPS acquired**. This means that the GPS position is received, but the user is not allowed to see it.

This also applies if the AVIATOR 700 is not yet registered on the BGAN network, but the GPS position is received.

- **Status.** The status of the system and antenna.

Status	Description
Scanning	The system is trying to logon to a satellite and waiting for the GPS position.
Ready	The system is ready for use.
Data Active	The data connection is active, data are transferred.
Logged off	<ol style="list-style-type: none"> 1. The SBU has logged off the I4 satellite and the AVIATOR 700 has switched over to an I3 satellite. Data services can be used over Swift64 through the SDU. 2. The AVIATOR 700 system is logged off.

- **Satellite selection.** The satellite selected for logon.
- **Current satellite.** The current satellite and elevation angle.
- **Unit serial number.** The serial number of the SwiftBroadband Unit of the AVIATOR 700 system.

- **Software version.** The version of the software embedded in the SwiftBroadband Unit.
- **Certification level.** This field shows whether the system is Level-D or Level-E certified.
- **IMSI number.** The IMSI number (International Mobile Subscriber Identity) of the system. It is a unique number that is stored on the SIM card inside the system and sent to the network.
- **IMEI number.** The IMEI number (International Mobile Equipment Identity) of the system. This is a unique number that identifies your system.

Viewing information on calls and data sessions

The following sections in the **Dashboard** show information on calls and data sessions.

- **ONGOING DATA SESSIONS** is a list of data profiles that are currently active, including the external IP address that is assigned to each profile.
- **SESSIONS TOTAL** lists the totals for each connection type. The list shows the time connected for voice and Streaming data, and MB transferred for Standard data.
- **ONGOING CALLS** is a list of calls that are currently active. The list shows the call type and the time connected for each call.

The counters show totals for connections since the counters were last cleared. For information on how to clear the counters, see *Call log handling* on page 180.

Use the SBU phone book

The phone book is stored in the Configuration module of the SBU in the AVIATOR 700 system. In the phone book you can:

- Look up phone numbers.
- Look up short-dial numbers for easy dialing from a handset.
- Modify or delete existing names and phone numbers, or add new names and phone numbers.

The numbers of the phones available on the aircraft and the mobile number of the system might already be entered when the system was initially configured.

To access the phone book

To access the phone book, select **PHONE BOOK** from the left navigation pane.

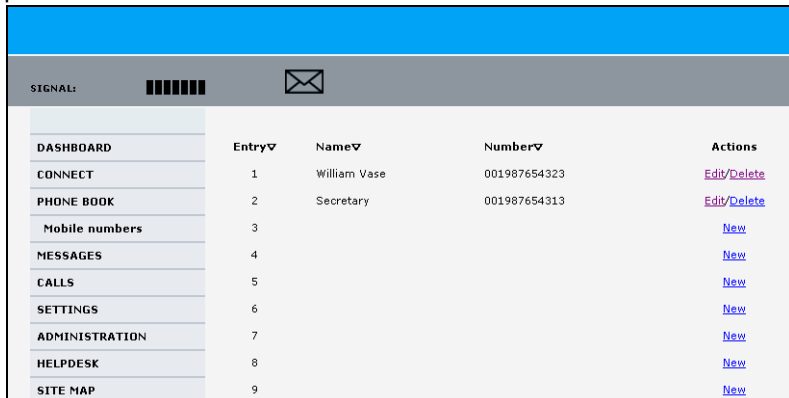

	Entry▼	Name▼	Number▼	Actions
DASHBOARD				
CONNECT	1	William Vase	001987654323	Edit/Delete
PHONE BOOK	2	Secretary	001987654313	Edit/Delete
Mobile numbers	3			New
MESSAGES	4			New
CALLS	5			New
SETTINGS	6			New
ADMINISTRATION	7			New
HELPDESK	8			New
SITE MAP	9			New

The phone book shows all entries with entry number, name and phone number. Empty placeholders are also included. The phone book holds 199 entries divided into subpages. To select the subpages you want, click the relevant link at the bottom of the page.

To sort the phone book, click the title of the column you wish to sort by. For example, to sort by the names in the phone book alphabetically, click on **Name** in the top row of the phone book.

Short dial

The entry number in the phone book is the Short dial number. When making a call from the system you can use this number instead of dialing the entire phone number. Dial:

00 <short dial> followed by **#** or off-hook key for short-dial numbers 1 - 99.

0 <short dial> followed by **#** or off-hook key for short-dial numbers 100 - 199.

Example: To call the third entry in the phone book from an analog phone, take the phone off hook and dial **003 #**.

To add a new entry

To add a new entry, do as follows:

1. In the phone book, locate the empty entry number where you want to add the new phone number and click **New**.
2. Type in the name and phone number of the new entry and click **Save entry**.

The new name and number are now listed at the specified entry number in the phone book.

To modify an entry in the phone book

To modify an entry, do as follows:

1. In the phone book, click **Edit** next to the entry you want to modify.
2. Modify the name or number as wanted and click **Save entry**.

The name and/or number in the selected entry is now replaced with the new information.

To delete an entry in the phone book

To delete an entry, click **Delete** next to the entry you want to delete.

To delete all entries in the phone book

To delete all the entries in the phone book, click **Delete all entries in phone book** at the bottom of the **PHONE BOOK** page.

To view the mobile numbers and additional numbers¹

To view the mobile numbers of the AVIATOR 700 system, select **PHONE BOOK > Mobile numbers** from the left navigation pane. The mobile numbers are the phone numbers to use when making a call to the AVIATOR 700 system.

Note

These numbers are not listed at delivery. They may have been entered during initial configuration of the system or can be entered at a later stage. The numbers are stated in the documentation from the service and airtime provider.

DASHBOARD	MOBILE NUMBERS
CONNECT	Standard voice 870772420567
PHONE BOOK	3.1 kHz audio 870782105234
Mobile numbers	UDI (64 kbps) 870782105235
MESSAGES	RDI (56 kbps) 870782105236
CALLS	Edit
SETTINGS	

The example above is for a system without Multi-voice.

To enter or edit the mobile numbers

To enter or edit the mobile numbers, click **Edit** at the bottom of the page, type in the numbers received from your service and airtime provider and click **OK**.

If Multi-voice is part of your system, the additional numbers from your airtime provider can be entered in the web interface

1. Available for systems with Multi-voice and subscriptions with additional numbers.

Use the Call log

The call log holds information on all calls and data sessions since it was last cleared.

Note

If power to the system is interrupted, the information stored in the Call log for the currently ongoing calls (connection time) and data sessions (transferred data) may be slightly inaccurate.

Information on total usage

To enter the CALLS page select **CALLS** from the left navigation pane. The CALLS page contains information on usage for circuit switched connections.

For more information on circuit switched services, see *Circuit switched (dialed) service* on page 19.

The listed information includes:

- time connected using Standard Voice
- time connected using 3.1 kHz Audio.

Export the call log

You can export the call log file for archiving, surveillance or other tracking purposes. The call log holds information on all calls and data sessions since the call log was last cleared. For information on how to view the lists of calls and data sessions, see the next section.

When there are more than 100 calls in the total list, the oldest calls are automatically removed to make room for new calls.

To export the entire call log to a file, do as follows:

1. In the **CALLS** page, click the link **Export call log to file**.
2. Browse to the location where you want to save the log.
3. Click **OK**.

View the lists of calls

To see information on outgoing, received or missed calls or data sessions, select one of the following lists from the left navigation pane in the **CALLS** page:

- **Outgoing calls** shows the start time, receiving end phone number, duration, type (Standard or 3.1 kHz Audio) and estimated charge of each outgoing call.
- **Received calls** shows the start time, calling phone number, duration and type (Standard or 3.1 kHz Audio) of each incoming call.
- **Missed calls** shows the start time, calling phone number and type (Standard or 3.1 kHz Audio) of each incoming call that was not received.
- **Standard data sessions** shows the start time, bytes in, bytes out and estimated charge of each Standard IP session.
- **Streaming data sessions** shows the start time, duration, type (Streaming 8, 16, 32, 64, 128 kbps or X-Stream) and estimated charge of each Streaming IP session.

Date and time is the international UTC time, received from the satellite. In casual use, UTC is the same as Greenwich Mean Time (GMT).

For information on the available types of service, see *AVIATOR 700 Services* on page 4.

Note

The estimated charge is based on your entries under ADMINISTRATION > Call charges. Thrane & Thrane does not take responsibility for the correctness of this estimated charge. This calculation is only a rough estimate of the charge, based on the tariff entered by the user. Also, the airtime provider may have different methods of calculating the charge.

You can sort each of the lists by clicking the title of the column you wish to sort by. If a list covers more than one page, you can click the relevant link at the bottom of the page, to go to another page.

View the Voice mail number

The Voice mail number is the number you call to hear your incoming voice mail.

Note

The Voice mail number is only listed if it is available on the SIM card. Otherwise, refer to the information included with your airtime subscription.

To see the Voice mail number, select

MESSAGES > Message settings from the left navigation pane. The **Voice mail number** field shows the Voice mail number.

Start or stop any data session

If necessary, you can start and stop any data session for all network user groups connected to the system. To use this feature you must login as an administrator.

To start or stop any data session, do as follows:

1. Select **CONNECT**.

If you are not yet logged in as an administrator, enter the administrator user name and password. The default user name is **admin** and the default password is **1234**. If the password has been changed, contact your system administrator.

Under ONGOING DATA SESSIONS at the top you can see which data sessions are currently active and which are allowed.

Example:

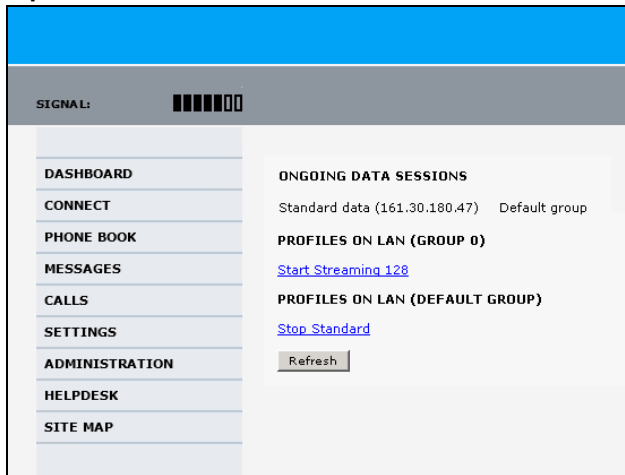

In the example above you could manually start the streaming 128 connection of the GROUP 0 and stop the standard connection of the DEFAULT GROUP.

2. Click on the session you want to start or stop.

Call log handling

To clear the logs of the system and/or reset the counters for the time connected, do as follows:

1. From the left navigation pane in the **ADMINISTRATION** page, select **Log Handling**.

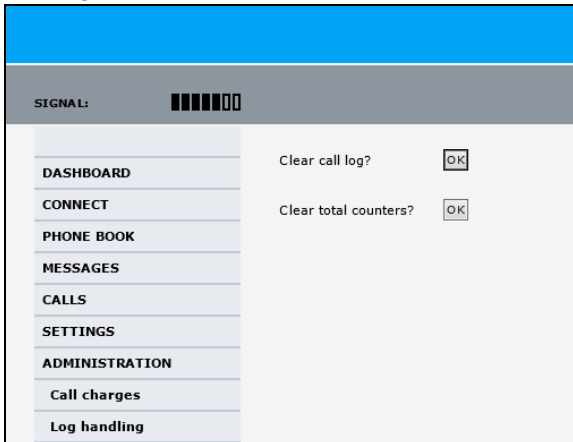

2. To clear the Call log, click **OK** next to **Clear call log?**.
3. To clear the total counters, click **OK** next to **Clear total counters?**. This resets the **Time connected** counters on the Calls page.

Set data limits

You can set a limit for the use of data services with the AVIATOR 700 system. You either specify a maximum number of MB for the standard data connection, and/or a time interval from start to end for a streaming connection.

If you have entered the call charges in the menu **Call charges**, the system automatically calculates and displays the maximum charges for your data sessions.

Note

Thrane & Thrane A/S does not take responsibility for the correctness of the estimated charges. This calculation is only a rough estimate of the charge, based on the tariff entered by the user. Also, the airtime provider may have different methods of calculating the charge.

Once the entered limit is reached, the connection is automatically stopped. This is recorded in the menu **CALL** containing a call log in which you can see information on standard and streaming data sessions. To continue using the data services you must start a new connection by clicking on the desired connection on the Dashboard.

Note

If you set a data limit for the Standard data connection, automatic activation of the Standard data connections is disabled for all network user groups.

To set data limits, do as follows:

4. From the left navigation pane in the **ADMINISTRATION** page, select **Data limits**.
5. Select the services to close automatically after a fixed amount of data or period of time.
For Standard data type in the number of mega bytes (MB) allowed.
For streaming classes select a period of time from the drop down list.
6. Click **Apply** to save the settings.

Set up the local exchange function

If you want to call a specific phone connected to the terminal, use the local exchange function. With this function enabled, when you dial the mobile number of the terminal, a recorded message instructs you to dial the number for the local phone you want to call. Your call is then transferred to the requested phone and only the requested phone rings.

If the local exchange is not used (**Incoming calls** not selected), incoming calls will per default cause all connected phones to ring.

To set up the local exchange, do as follows:

1. Select **SETTINGS > Common > Local exchange** from the left navigation pane.

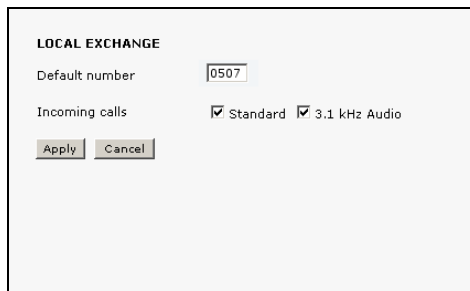

The screenshot shows a dialog box titled "LOCAL EXCHANGE". It contains the following fields and options:

- Default number:** A text input field containing "0507".
- Incoming calls:** Two checked checkboxes: "Standard" and "3.1 kHz Audio".
- Buttons:** "Apply" and "Cancel".

2. Type in the local number to which incoming calls are transferred to if the caller dials * after calling the mobile number, or the caller dials nothing after the recorded message.
3. Select the call types you want to direct to the local exchange.
If you use 3.1 kHz Audio for a fax machine only, do not select 3.1 kHz Audio as this line is used for the fax.
If no call type is selected, the local exchange function is disabled (default setting).
4. Click **Apply**.

Remote management and activation

Note

Note that only the **SBU** of the AVIATOR 700 can be accessed remotely.

Some setup tasks must be done on the SBU before being able to use the remote function. These tasks are described in the following sections.

Prepare the AVIATOR 700 for remote management

1. Verify that the AVIATOR 700 is correctly set up for this feature. How to set up this feature is described in the Installation and Maintenance Manual.
2. Activate a data connection in one of the following ways:
 - Remote activation with SMS.
 - Automatic activation of a data connection (not remote).
 - Manual activation of a data connection (not remote).
3. Note the system's external IP address, found in one of the following ways:
 - Unmanned SMS activation: You will receive an SMS with the IP address when the system is powered up and operational.
 - Connect a computer locally to the system and start the web interface. The IP address of the system is shown in the Dashboard under ONGOING DATA SESSIONS (in parenthesis).

This is the IP address you must use to access the system remotely.

If Static IP address is included in your airtime subscription, we recommend using this IP address for the system in order to provide easy access to the system.

Access the AVIATOR 700 from a remote location

To access the SBU from a remote location, do as follows:

1. On the remote computer, open a web browser.
2. Enter the IP address of the SBU followed by colon and the port number **http://<ip address>:<incoming port>**.

- <ip address> is the address from step 3 above.

Note

Contact your installation center for further information on the SBU IP address and port number. Your system may have a static IP address that is assigned each time when the SBU logs on.

- <incoming port> is the port that has been defined during system installation.

Example: If the IP address of the SBU is 161.30.180.12 and the incoming port number defined in the Remote management page in the web interface is 8080, enter **http://161.30.180.12:8080**.

You are now connected to the SBU from the remote computer.

Remote activation of the SBU with SMS

If you want to remotely control the system, it must have activated a connection. You can do this by sending an SMS to the system. The system must be powered up and logged on to the satellite services to receive the SMS and then start the connection. The SMS activation is always protected by a password. You can set up the system to send an SMS confirmation on the status of the connection, whether it is activated successfully or the activation failed.

Note

The system must be logged on to the satellite services to receive and accept an activation SMS. If the SMS is considered too old or sent before the system has been switched on and has logged on, the SMS will be ignored.

Important

This service is available if the service provider has an interoperability agreement with Inmarsat that allows for roaming. If in doubt, contact your service provider.

To set up the system for remote activation with SMS, do as follows:

1. From the left navigation pane, select **ADMINISTRATION > Remote activation**.

REMOTE ACTIVATION

Remote activation of data sessions Enabled Disabled

Send confirmation Enabled Disabled

Password

TRUSTED NUMBERS

Number

Number

Number

Number

Number

2. Select whether remote activation should be **Enabled** or **Disabled**.

3. Select whether confirmation by SMS should be **Enabled** or **Disabled**.
4. Enter the password. It can be up to 32 characters long. The characters 0-9, a-z and A-Z are allowed. The password is mandatory and must match the password in the activation SMS.
5. Enter at least one trusted mobile number from which the system accepts an activation SMS. If no numbers are entered the feature is disabled automatically. Use the wild card * to accept a range of trusted numbers.

Mobile number with wild card	Mobile numbers accepted
00453955880*	004539558800 to 004539558809
0045395588*	004539558800 to 004539558899

6. Click **Apply** to save the new settings.

SMS format

The activation SMS must have the following format for activating and deactivating a connection in the SBU:

- `ACTIVATE <name of network user group> : <name of profile>
<password>`
- `DEACTIVATE <name of network user group> : <name of profile>
<password>`

The password is case sensitive, the words ACTIVATE and DEACTIVATE are not.

Examples for SMS

- Open a Standard data connection in the Default network user group:
`ACTIVATE default group:standard 1234567890`
- Close a Streaming 32 connection in the network user group Group 0:
`DEACTIVATE Group 0:streaming 32 1234567890`

Note that one profile is allowed per SMS.

Restricted dialing

In order to manage the use of the system efficiently you can set up the system to limit all calls to allowed numbers or numbers in the phone book. This feature can be enabled for each connected handset separately. Each handset has its own local number.

To set up the system for restricted dialing, do as follows:

1. From the left navigation pane, select **ADMINISTRATION > Restricted dialing**.
2. Select whether restricted dialing should be **Enabled** or **Disabled**.
3. Type in the allowed numbers or masks in the entry fields.
The numbers or masks must be max. 32 digits and may start with +. No other special characters are allowed. A mask is the first part of a phone number, and it covers all numbers that start with that first part. See the example below.

Mask	Numbers accepted
00453955880	004539558800 to 004539558809
+45395588	004539558800 to 004539558899

4. Select whether outgoing calls should be limited to the numbers in the terminal phone book (Enabled) or not (Disabled).
5. Check which local numbers are available in your system. Then select for which local numbers you want to enable the restriction.
6. Click **Apply** to apply the new settings.

RESTRICTED DIALING

Restricted dialing Enabled Disabled

Allowed numbers or masks

<input type="text"/>	<input type="text"/>
<input type="text"/>	<input type="text"/>
<input type="text"/>	<input type="text"/>
<input type="text"/>	<input type="text"/>
<input type="text"/>	<input type="text"/>
<input type="text"/>	<input type="text"/>
<input type="text"/>	<input type="text"/>
<input type="text"/>	<input type="text"/>

Phonebook dialing

Limit outgoing calls to numbers in terminal phonebook Enabled Disabled

PHONE STATUS

0301 (Phone)	<input checked="" type="checkbox"/> Restrictions enabled
0302 (Phone)	<input checked="" type="checkbox"/> Restrictions enabled
0401 (ISDN)	<input type="checkbox"/> Restrictions enabled
0411 (ISDN)	<input type="checkbox"/> Restrictions enabled
0501 (IP handset)	<input checked="" type="checkbox"/> Restrictions enabled
0502 (IP handset)	<input type="checkbox"/> Restrictions enabled

Troubleshooting

In this chapter

In this chapter you can read about:

- *Get support*
- *SDU errors*
- *SBU errors*
- *System LEDs*

Get support

If this manual does not provide the remedies to solve your problem, you may want to contact your service provider, your aircraft installation and service center or your local distributor.

The web interface of the SBU provides a help desk, event logs and event lists. The system can also generate a diagnostic report for service and maintenance purposes.

Airtime support

If you need assistance from your service provider, call the help desk. To see the help desk number, enter the web interface of your system and select **HELP DESK**. This displayed help desk number is either taken from the SIM card or entered manually. If no number is available under HELP DESK, check the documentation of your service provider for a contact number.

System support

If you need assistance when solving problems caused by the system or antenna, please call a distributor in your area. A list of certified partners and distributors is available on Cobham SATCOM's web site:

www.cobham.com/satcom. Select **Technical Service Partner List**.

SDU errors

In case of a fault situation, first check that the LED for H⁺ (Classic Aero) in the handset is lit, and that the display reads as shown below:

Ready
AMER AM #x

H+	SBB	SW64
ok	0/1	ok

14 satellite logon ok *13 satellite logon ok*

Also make sure that the transmission path is not obstructed, e.g. by buildings if the aircraft is on the ground.

The AVIATOR 700 system has different means of status signalling:

- **Error Messages.** The AVIATOR 700 system is able to display various error messages to help you troubleshoot the system. The following sections provide an overview and a list of some of the error messages you may see in the display.
- **LEDs.** For information on the LEDs on the handsets, see *System LEDs* on page 206. Furthermore, the SDU and HPA are equipped with LEDs for signalling their status. These LED functions are described in the section *System LEDs* on page 206.

When contacting your distributor for support please enclose a service log for the SDU. A service log is generated using the Aero-SDU Configuration Program. For further information see the AVIATOR 700 Installation and Maintenance Manual.

Error messages

If there is a fault, the type of fault and the fault code is displayed in the Full Feature handset. Where possible the fault code is translated into plain text. Two types of fault codes are defined:

- BITE (Built-In Test Equipment) errors
- Cause Codes

For a complete list of BITE error codes and Cause Codes, please refer to the Installation and Maintenance Manual.

BITE errors

A BITE error is a hardware error detected by the built-in test equipment in the SDU.

The red LED on the handset indicates the presence of a fatal or essential BITE error.

- A **fatal** BITE error means that you are logged off and cannot log on again.
- An **essential** BITE error means that the functions are limited and one or more services are not available.
- A **non-essential** BITE error means that there are minor errors, but all services are still available. The red LED on the handset will not indicate this type of error.

Please report any BITE errors to the Maintenance Responsible.

When a BITE error is present, the display toggles between the active event and the previous display contents.

The BITE error is shown in the second line of the display. A BITE error has a unique 4-character BITE code.

You can also view any active BITE errors in the **Status** menu under **Active Errors**.

A list of BITE error codes is available in the AVIATOR 700 Installation and Maintenance Manual.

Cause codes

A Cause Code describes a fault detected by the Earth Station during a call.

The cause codes can help you find the reason for an error. In most cases, errors are caused by a problem in the satellite network.

The Cause Code is displayed in the handset for a few seconds after the call is interrupted. If possible, the code is translated into plain text instead of the Cause Code. A Cause Code is a unique 4-character code.

The Cause codes are divided into two types:
Logon Reject cause codes and Call Reject cause codes.

- Logon Reject cause codes appear during logon attempts.

- Call Reject cause codes appear after logon, during call attempts.

The following section shows the two lists of H⁺ cause codes with explanations of the error messages.

List of H⁺ Cause codes

Note Cause Codes should not be mistaken for BITE error codes. See the previous page for an explanation of the two kinds of error codes.

Logon Reject Cause Codes

The following list shows the cause codes that may appear during logon.

Display Text	ID	Description	Guidance
ClassReject	0x88	Class rejected	The GES does not support this class.
GlobChanLoss	0x82	Global channel loss	Verify that there are no obstacles between the satellite and the AES antenna.
GlobCunavlb	0x09	Global C channel not available at GES	
ManualLogRej	0x89	Manual login rejected	Manual logon is not allowed when logon policy is automatic.
NetworkFail	0x03	Network Failure	
NoGesSignal	0x81	No GES signal	
NoInitData	0x86	No valid system table available	

Display Text	ID	Description	Guidance
NoSatSignal	0x80	No satellite signal	Verify that there are no obstacles between the satellite and the AES antenna.
NotAuthorizd	0x0F	AES not authorized	Verify that the ICAO address used is correct. Verify that the ICAO address is registered, by contacting the service provider.
OtherReason	0x0E	Other Reason	
OutsideCover	0x84	Outside spot beam coverage	The AES is not under a spot beam of the specified GES.
P/R/Tunavlb	0x07	Packet data channel unavailable	
PkdtaUnavlb	0x08	Packet data service unavailable	
SatHandover	0x8C	Satellite handover	
SDUfailure	0x8A	SDU failure	Check the current BITE errors.
SpotChanLoss	0x83	Spot channel loss	
TableFull	0x00	Table Full	
UserLogoff	0x87	User logoff	
VCC&dUnavlb	0x0A	Voice not available at GES	
VoiceUnavlb	0x01	Voice Unavailable	

Display Text	ID	Description	Guidance
WrongGES	0x85	GES not existing	Check GES ID validity.
WrongGESid	0x06	Wrong GES identifier	Check GES ID validity.
WrongParam	0x02	Wrong Parameter	
WrongSatID	0x05	Wrong Satellite identifier	Check satellite ID validity.

Call Reject Cause Codes

The following list shows some of the cause codes that may appear when the system is logged on. The SLCV codes refer to: S = coding Standard, L = cause Location, C = cause Class, V = cause Value.

Display text	Code				Description
	S	L	C	V	
0 0 1 0	0	0	1	0	Normal clearing by called/calling party
1 1 7 15	1	1	7	15	Undefined cause
1 2 7 15	1	2	7	15	Undefined cause
1 3 7 15	1	3	7	15	Undefined cause
1 4 7 15	1	4	7	15	Undefined cause
AddrComplete	1	3	0	1	Address complete signal sent to terrestrial network
AddrComplete	1	6	0	1	Address complete signal received from terrestrial network
AESabsent	1	3	7	3	Calling/called AES not logged-on to system

Display text	Code				Description
	S	L	C	V	
AnalogFail	1	4	2	3	Analog data equipment not supported at GES
AnalogRate	1	4	6	2	Analog data rate not supported by GES
CallBarred	1	4	4	3	Called AES barred for incoming calls
CallPreempt	1	1	1	1	Preemption by higher priority call at AES
CardInvalid	1	3	6	1	Credit card type not supported by GES
CardRejected	1	3	3	1	Credit card number rejected by GES
DigitalFail	1	4	2	4	Digital data equipment not supported at GES
DigitalRate	1	4	6	3	Digital data rate not supported by GES
Handover	1	3	7	4	Spot beam handover
InvalidAddr	1	2	3	2	Call Ann. / C-ch. Assign. not recd. from GES
InvalidAddr	1	3	3	2	Incomplete called (AES) number
InvalidAddr	1	4	3	2	Invalid called number format received from AES
InvalidNumbr	0	4	1	12	Incomplete called number format from AES
Network busy	1	2	5	1	C-channel continuity test failure at AES/ Connect acknowledge not received by AES

Display text	Code				Description
	S	L	C	V	
Network busy	1	3	5	1	C-Channel continuity test failure at GES/AES not responding/ Incomplete call information received from AES/ Interruption in received AES carrier/ Connect acknowledge not received by GES
NoAnswer	0	1	1	2	Expiry of answer time supervision at AES
NoAnswer	0	4	1	2	Expiry of answer time supervision at the MSSC
NoChanAvail	1	3	2	1	C-channel frequency/power unavailable at GES
NoUnitAvail	1	2	2	2	C-channel unit unavailable at AES
NoUnitAvail	1	3	2	2	C-channel unit unavailable at GES
SatDestFail	1	1	4	1	Called AES terminal not in service
ServiceType	1	3	6	5	Service type not supported by GES
SwitchBusy	0	2	2	10	GES equipment congestion
SwitchBusy	0	4	2	10	GES equipment congestion/ No route to destination from GES/ Circuit to terrestrial network unavailable
UnassignedNo	1	4	7	2	AES not authorized for service
Unauthorised	1	3	4	2	Calling AES not authorized for service
UserBusy	1	1	7	1	Called AES terminal busy

Display text	Code				Description
	S	L	C	V	
UserBusy	1	3	7	1	Call reference number unavailable at GES
VoiceTypeErr	1	2	6	4	Required voice channel characteristics not supported by AES
VoiceTypeErr	1	3	6	4	Required voice channel characteristics not supported by GES
WrongNumber	0	4	0	1	Unallocated called number received from AES

SBU errors

Access the Help desk

If you need help **with airtime-related issues** you may call the Help desk. By default, the Help desk is the phone number for your Airtime Provider, if it is available on the SIM card.

To access the Help desk, select **HELP DESK** from the left navigation pane.



If the Help desk number is available on the SIM card, the number is displayed as a link. To change the number, click the link, change the number and click **Apply**.

If you need help **with system or antenna related issues** call your local distributor.

Generate a diagnostic report

The SBU can generate a diagnostic report. This report contains information relevant for the service personnel during maintenance and troubleshooting. If you have reason to believe the system is malfunctioning you can generate such a report, save it and send it to the system responsible.

To generate a diagnostic report with valuable information for the service team, do as follows:

1. Reboot the system.
2. Establish the problem or situation in which the error occurred, or
3. Make a CS call (if possible), i.e. making a call with a handset connected to the SBU.
4. Make a PC call (if possible), i.e. establish a data connection.
5. Click **Generate report** from the **HELP DESK** page.
In some browsers the file may open directly in your browser. If it does, choose **File > Save As** to save the file.
6. Choose a location for the file and save it on your computer.
7. Send it to your system administrator.

Event log and self test

The SBU logs events and results from self tests. This information is useful during maintenance and troubleshooting. For further information how to view the event list and the event log and how to make a self test see the AVIATOR 700 Installation and maintenance manual.

SBU Troubleshooting guide

The below table provides information on some of the problems that might occur, including possible causes and remedies to solve the problems.

Problem	Possible Cause	Remedy
No signal or weak signal from the BGAN satellite.	The view to the satellite is blocked.	There might be some temporary loss of signal due to parts of the plane blocking for a clear view of the satellite. This temporary loss of signal will pass when the antenna has a full view of the satellite again.
	The system is not fully operational.	Wait until the system is powered up and fully operational. There might be an indicator in the cabin indicating that the satcom system is ready for use.

Problem	Possible Cause	Remedy
Connection to the Internet cannot be established.	Your system is set up to start a connection in the web interface manually.	Open your Internet browser and enter the default IP address of the SwiftBroadband Unit: http://192.168.0.1 (default address). Click Start Standard to open a standard data connection manually. For more details see <i>Start or stop a Standard connection</i> on page 110.
	WLAN security not set up correctly.	Contact your system administrator for encryption keys for your Wireless interface.
	No Wireless in the cabin.	The wireless feature is not enabled or not installed. Use a LAN connection instead.
	Your network user group does not allow Internet access.	Contact the administrator to change your network user group to allow Internet access. You might need to start a standard data connection. For more details see <i>Start or stop a Standard connection</i> on page 110.

Problem	Possible Cause	Remedy
<p>The web interface cannot be accessed.</p>	<p>The browser of your PC is configured to use a proxy server.</p>	<p>For Microsoft Internet Explorer, select Tools > Internet Options > Connections > LAN Settings and uncheck Use a proxy server for your LAN.</p>
	<p>You have entered a wrong IP address.</p>	<p>Check the IP address and re-enter it. Default value: <code>http://192.168.0.1</code></p> <p>Send a ping request in the command prompt window.</p> <p>If you do not have the correct IP address, contact your system administrator.</p>
	<p>WLAN security not set up correctly.</p>	<p>Contact your system administrator for encryption keys for your Wireless interface.</p>
	<p>No WLAN in the cabin.</p>	<p>You try to make a connection using WLAN, but there is no WLAN antenna in the cabin. Use a LAN connection instead.</p>
	<p>You are connected using a VPN connection.</p>	<p>Close down your VPN connection.</p>

Problem	Possible Cause	Remedy
A Phone/Fax connection cannot be established.	The phone cable is not properly connected.	Connect the phone cable.
	The cable type or connector type is not correct.	For information on the correct type of connector and cable, refer to the installation manual.
	Incoming calls: The call type used for the call is not selected in the web interface.	Make sure the call type used for calls to the system is selected in the web interface. Access the web interface and select SETTINGS > Phone/Fax . Then, for each of the two ports, select the call type for incoming calls.
	The fax machine times out.	Set the fax machine to overseas mode, allowing for longer time intervals before timing out.

Problem	Possible Cause	Remedy
An ISDN connection cannot be established	The cable is not properly connected.	Connect the cable.
	You have connected to the LAN interface.	Connect the cable to the interface marked ISDN.
	The cable type or connector type is not correct.	For information on the correct type of connector and cable, refer to the installation manual.
	Incoming phone calls: The call type used for the call is not selected in the web interface.	Make sure the call type used for calls to the system is selected in the web interface. Access the web interface and select SETTINGS > ISDN . Then select the call type for incoming calls.
A LAN connection cannot be established.	The cable is not properly connected.	Connect the cable.
	You have connected to the ISDN interface.	Connect the cable to the interface marked LAN.
	The cable type or connector type is not correct.	For information on the correct type of connector and cable, refer to the installation manual.

Problem	Possible Cause	Remedy
An IP handset connection cannot be established.	The built-in WLAN option is not enabled.	Have the WLAN option enabled by your system administrator.
	The passwords in handset and terminal do not match.	Match the passwords. For instructions see the user manual for the AVIATOR Wireless Handset.
	The WLAN encryption code does not match.	Check that you have the correct encryption code for accessing the WLAN access point. The encryption code is set up in the web interface under SETTINGS > WLAN .
The administrator password does not work.	The administrator password has been changed.	<p>If the correct password is not found, you have to reset the password.</p> <p>Contact your system administrator, then your supplier for a reset code. You must provide the serial number and IMEI number of the SwiftBroadband Unit.</p>

System LEDs

SDU LEDs

SDU Power LED

The function of the power LED on the SDU is as follows:

LED Color	Description
Green	Power OK
Orange	Uploading software
Off	No power

SDU Logon LED (H⁺)

The Logon LED on the SDU shows the H⁺ logon status. The HSD logon status is only signalled in the Full Feature handset.

The possible colors are listed below, with a short description of what they indicate:

LED Color	Description
Off	No acquired satellite
Red	Acquired a network satellite
Orange	Network synchronization
Green	Network logon

SDU Fail/Pass LED

The function of the Fail/Pass LED on the SDU is:

Behavior	Description
Steady red	Fail
Alternating: Short green / long pause	Power On Self Test (POST) or Person Activated Self Test (PAST) in progress
Alternating: Long green/ short orange 0.5 Hz	No current failure, but a BITE failure/warning is logged in the error log
Steady green	No faults

HPA LEDs

HPA Power LED

The function of the power LED on the HPA is as follows:

LED Color	Description
Steady green	Power OK
Off	No power

HPA Fail/Pass LED

The function of the Fail/Pass LED on the HPA is:

Behavior	Description
Steady red	Fail
Off	No faults

SBU LEDs

During the power-up procedure all LEDs on the front plate are orange. If all 3 LEDs on the front stay orange after power up, there can be several reasons:

- The SBU software is corrupted.
- The SBU Enable pin has not been wired properly in the installation. For further information see the AVIATOR 700 Installation and Maintenance Manual, chapter 5.3 Electrical installation and wiring, 5.3.2 Wiring SDU to SBU.

SBU Power LED

The function of the Power LED on the SBU is:

Behavior	Description
Green	Power OK
Orange	During upstart procedure
Off	No power

SBU Logon LED

The function of the Logon LED on the SBU is:

Behavior	Description
Red	Acquiring satellite network
Orange	Network synchronization
Green	Network logon
Off	No acquired satellite/logged off

SBU Fail/Pass LED

The function of the Fail/Pass LED on the SBU is:

Behavior	Description
Steady red	A fault which may degrade the system operation is present in the SBU
Flashing: short green/ long pause	Power On Self Test (POST) or Person Activated Self Test (PAST) in progress
Flashing: long green/ short orange	No current failure, but a BITE failure / warning is logged in the error log
Steady green	No faults

SBU LED on maintenance connector

The function of the LED on the maintenance connector is:

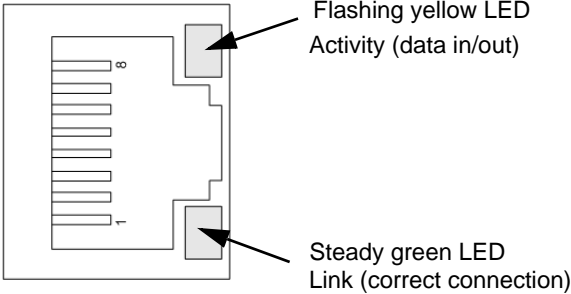

Menu trees

The next pages show an overview of the menu trees for the system:

- *Menu tree for the Full Feature handset*
- *Menu tree for the MCDU*
- *Menu tree for the SBU*

For details the menus, refer to the section *Full Feature handset operation (SDU)* on page 113, *MCDU operation* on page 149 and *Use the SBU web interface* on page 164.

Menu tree for the Full Feature handset

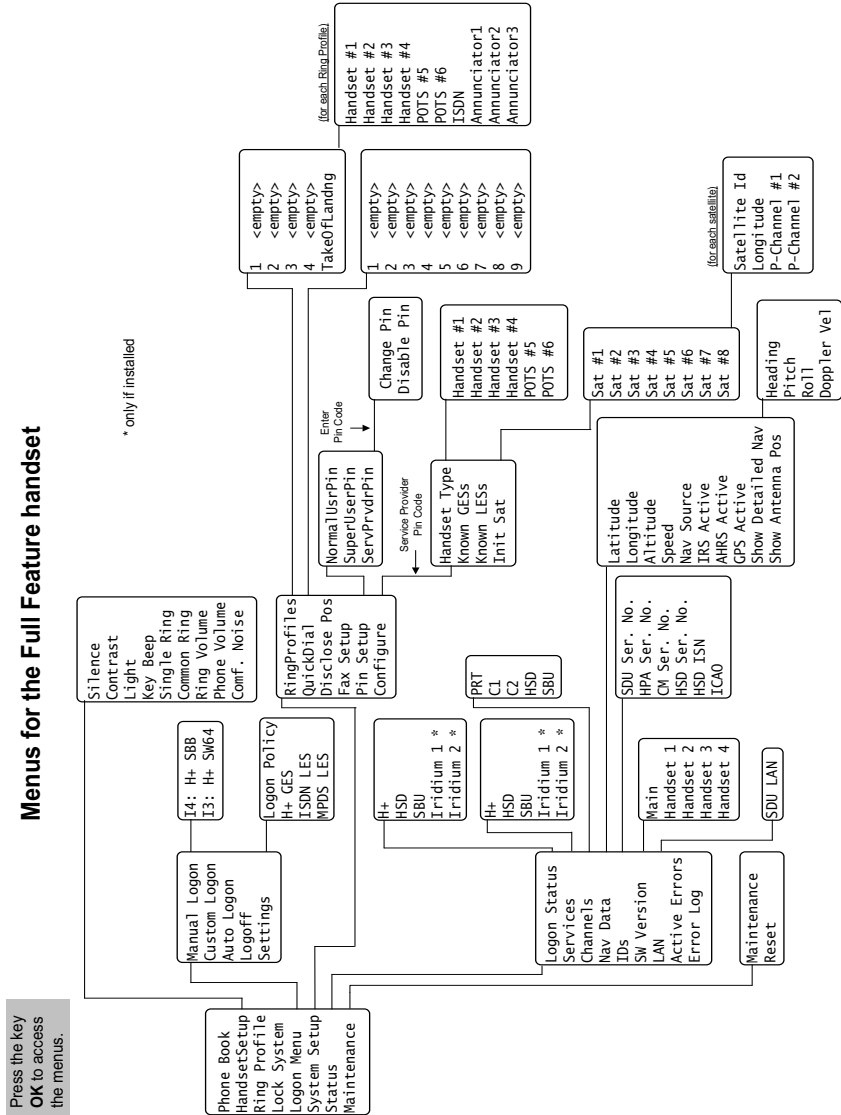

Menu tree for the MCDU

Menus for the MCDU (SATCOM)

(with 1 cockpit audio connected)

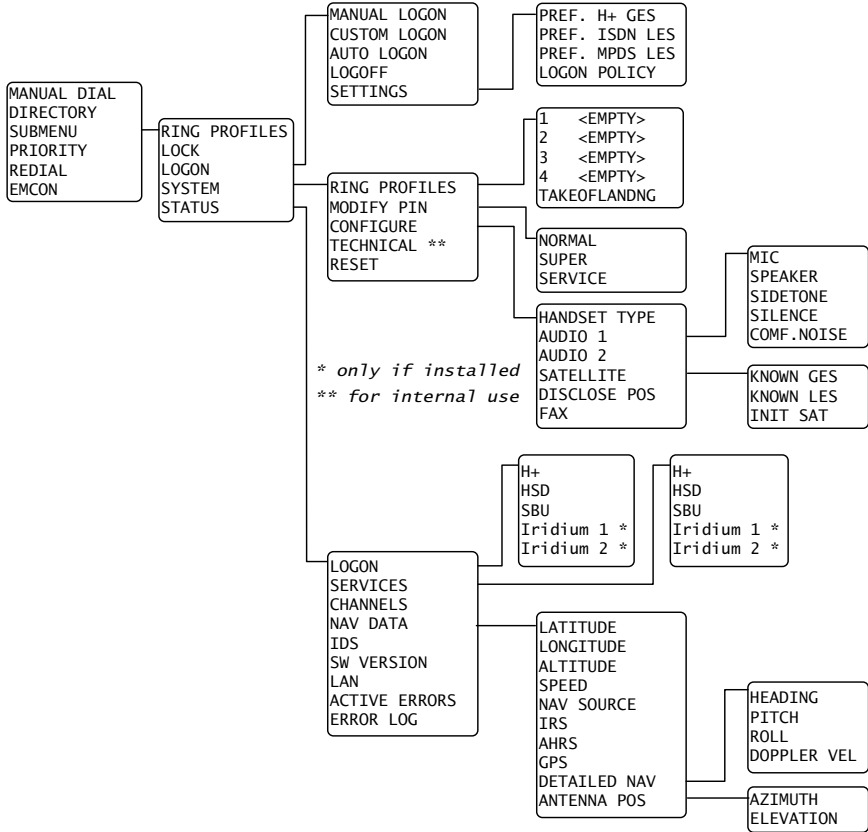

Menu tree for the SBU

The topics in gray are mainly used during installation and maintenance of the system, they are described in detail in the AVIATOR 700 Installation and maintenance manual.

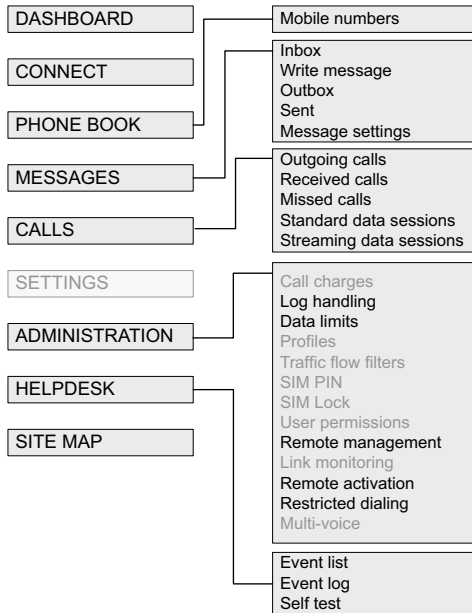

List of available GESs

If you need to log on to a GES which is not in the list of known GESs, you can use the Custom Logon function. See *To make a custom logon* on page 125. When you make a custom logon, you need to enter the Sat ID and GES ID for the GES you want to log on to. To find the Sat ID and GES ID, you may use the list below. The following table shows a list of available GESs supporting Classic Aero (H⁺).

Ocean Region	Sat ID	GES ID	Name	Abbr.
AORW	00	002	Eik (Burum)	EK (BR)
AORW	00	005	Aussaguel (Burum)	AS (BR)
AORE	01	067	Aussaguel (Burum)	AS (BR)
AORE	01	068	Eik (Burum)	EK (BR)
POR	02	130	Santa Paula (Perth)	SP (PH)
POR	02	133	Perth (Perth)	PH (PH)
IOR	03	193	Eik (Perth)	EK (PH)
IOR	03	197	Perth (Perth)	PH (PH)
MTSAT	04	161	MTSAT	KH
APAC (I4)	05	080	Hawaii	HW
EMEA (I4)	06	144	Fucino	FC
AMER (I4)	07	208	Hawaii	HW

Conformity

FCC

15.19 / RSS-GEN

NOTICE:

This device complies with Part 15 of the FCC Rules. Operation is subject to the following two conditions:

1. this device may not cause harmful interference, and
2. this device must accept any interference received, including interference that may cause undesired operation.

15.21

NOTICE:

Changes or modifications made to this equipment not expressly approved by (manufacturer name) may void the FCC authorization to operate this equipment.

15.105

NOTE: This equipment has been tested and found to comply with the limits for a Class B digital device, pursuant to Part 15 of the FCC Rules. These limits are designed to provide reasonable protection against harmful interference in a residential installation. This equipment generates, uses and can radiate radio frequency energy and, if not installed and used in accordance with the instructions, may cause harmful interference to radio communications. However, there is no guarantee that interference will not occur in a particular installation. If this equipment does cause harmful interference to radio or television reception, which can be determined by

turning the equipment off and on, the user is encouraged to try to correct the interference by one or more of the following measures:

- Reorient or relocate the receiving antenna.
- Increase the separation between the equipment and receiver.
- Connect the equipment into an outlet on a circuit different from that to which the receiver is connected.
- Consult the dealer or an experienced radio/TV technician for help.

ICES-003

This device complies with Industry Canada licence-exempt RSS standard(s). Operation is subject to the following two conditions:

- (1) this device may not cause interference, and
- (2) this device must accept any interference, including interference that may cause undesired operation of the device.

Le présent appareil est conforme aux CNR d'Industrie Canada applicables aux appareils radio exempts de licence. L'exploitation est autorisée aux deux conditions suivantes:

- (1) l'appareil ne doit pas produire de brouillage, et
- (2) l'utilisateur de l'appareil doit accepter tout brouillage radioélectrique subi, même si le brouillage est susceptible d'en compromettre le fonctionnement.

NOTICE:

This Class [B] digital apparatus complies with Canadian ICES-003.

Cet appareil numérique de la classe [B] est conforme à la norme NMB-003 du Canada.

A

ACARS	Aircraft Communication Addressing & Reporting System
AES	Aircraft Earth Station
AFIS	Automatic Flight Information Service
AMER	Americas (Satellite coverage)
ANSI	American National Standards Institute, facilitates the voluntary establishment of standards.
AORE	Atlantic Ocean Region East (Satellite coverage)
AORW	Atlantic Ocean Region West (Satellite coverage)
APAC	Asia Pacific (Satellite coverage)
ARINC	Aeronautical Radio, Incorporated

B

BGAN	Broadband Global Area Network
BITE	Built-In Test Equipment. A BITE error is a hardware error detected by the automatic error detection system in the satcom system.
Broadcast call	A call that is made to all handsets simultaneously. The first handset that replies establishes the connection, and the other handsets are disconnected from the call.

C

C-Channel	A bidirectional communications channel between ground and air. C-channels are typically used for voice communications.
-----------	--

CMU Communications Management Unit

CS Circuit-Switched. Circuit-switched networks require dedicated point-to-point connections during calls.

D

DHCP Dynamic Host Configuration Protocol for assigning IP addresses to devices on a network

E

EMEA Europe, Middle East, Africa (satellite coverage)

F

FNBDT Future Narrowband Digital Terminal. A US Government standard for secure voice communication.

G

GES Ground Earth Station. Earth Station used to route satellite communication using the H+ service.

H

HSD High-Speed Data

I

ICAO International Civil Aviation Organization. An ICAO address is a unique 24-bit number assigned to an aircraft by the civil aviation authority of the state in which the aircraft is registered.

IMEI International Mobile Equipment Identity. A unique number identifying your terminal

IMSI	International Mobile Subscriber Identity)
IMSO	International Mobile Satellite Organisation. An intergovernmental organisation that oversees certain public satellite safety and security communication services provided via the Inmarsat satellites.
IOR	Indian Ocean Region (Satellite coverage)
ISDN	Integrated Services Digital Network
ISN	Inmarsat Serial Number
ISP	Inmarsat Service Provider

L

LAN	Local Area Network
LCD	Liquid Crystal Display
LED	Light Emitting Diode
LES	Land Earth Station. Earth Station used to route satellite communication using the HSD service.

M

MB	Mega Bytes
MCDU	Multifunction Control and Display Unit. Part of the Flight Management System.
MPDS	Mobile Packet Data Service
MTSAT	Satellite service, Classic Aero only

N

NAT Network Address Translation, handles the conversion of the public WAN IP to 253 private LAN IPs.

P

PAST Person Activated Self Test

PBX Private branch exchange, a telephone exchange that serves a particular business or office.

P-Channel A channel which provides a unidirectional dedicated communications channel from a GES to all aircraft. Data packets are broadcast over this channel and addressed to a specific aircraft.

PIN Personal Identification Number

POR Pacific Ocean Region (Satellite coverage)

POST Power On Self Test

POTS Plain Old Telephony System. Traditional 2-wire system.

PS Packet-Switched. Packet-switched networks move data in separate, small blocks (packets) based on the destination address in each packet.

R

RDI Restricted Digital Information

RTCA Radio Technical Commission for Aeronautics

S

SBB	SwiftBroadband. Simultaneous voice and broadband data up to 432kbps per channel.
SMS	Short Messaging Service
STU	Secure Telephone Unit
SW	Software

T

TCP	Transmission Control Protocol. One of the core protocols of the Internet protocol suite. TCP provides reliable, in-order delivery of a stream of bytes, making it suitable for applications like file transfer and e-mail.
-----	--

U

UDI	Unrestricted Digital Information
UTC	Coordinated Universal Time. The International Atomic Time (TAI) with leap seconds added at irregular intervals to compensate for the Earth's slowing rotation. Leap seconds are used to allow UTC to closely track UT1, which is mean solar time at the Royal Observatory, Greenwich.

Numerics

- 2.4GHz Cordless
 - phone system, 13
- 2nd functions
 - Full Feature handset, 68
- 2-wire interface
 - local numbers, SBU, 53
 - local numbers, SDU, 40
- 3.1 kHz audio, 22
- 64 kbps
 - UDI, 22

A

- access levels, 114
- activation
 - remote, 185
- activation SMS, 186
- active error, SDU, 148
- adding
 - GES, known, 140
 - GES, preferred, 128
 - ISDN LES, preferred, 129
 - LES, known, 141
 - MPDS LES, preferred, 129
 - phone book entry, SDU, 116
- additional numbers
 - enter, 175
- AHRS active, 146
- airtime
 - unintended user of, 107
- alarm
 - view active, SDU, 148
 - view log, SDU, 148
- allowed numbers
 - restricted dialing, 187

- alpha mode, key functions, 70
- alpha-numeric keys
 - Full Feature handset, 69
- altitude, 146
- analog phone
 - local numbers, SBU, 53
 - local numbers, SDU, 40
- annunciators
 - SDU, 135
- answering a call
 - 2.4GHz Cordless handset, 80
 - Sigma7 handset, 79
 - Thrane & Thrane handsets, 71, 76
- antenna
 - viewing status, 171
 - viewing type, 171
- antenna position, 146
- applications, 1
- audio quality, 34, 46
- automatic shut down
 - connection, 181
- Auxiliary cradle, 12
- Auxiliary handset, 12

B

- BITE error codes, 191
- booting, 25
- broadcast ringing tone
 - disabling for selected interfaces, 132
- browser settings
 - for web interface, 165

C

call

- answering, 71, 76
 - forwarding, SBU, 58
 - from Auxiliary handset, 73
 - from Full Feature handset, 71
 - from POTS handset, 73
 - holding, MCDU, 92
 - holding, SBU, 56
 - holding, SDU, 41
 - incoming, in MCDU display, 84
 - local, MCDU, 90
 - local, SBU, 52
 - local, SDU, 39
 - making or receiving, SBU, 49
 - making or receiving, SDU, 37
 - manual, MCDU, 88
 - missed, received, outgoing, SBU, 177
 - priority, MCDU, 90
 - Quick dial, Full Feature handset, 72
 - redial, SBU, 53
 - to the SBU, 51
 - to the SDU, 38
 - transfer, Full Feature handset, 41
 - transferring, MCDU, 92
 - transferring, SBU, 57
 - using ISDN, 80
 - using phone book, Full Feature handset, 72
 - viewing ongoing, SBU, 172
 - waiting indication, SBU, 55
- call costs
- SIP-enabled IP phone, 81
- call limiting, 187
- call log, SBU, 176
- call priority
- MCDU, 150
 - call type, 34, 46
 - override, SBU, 47
 - call type H+, 36
 - call type HSD, 36
 - Caps toggle, 69
 - Cause codes, 191
 - list of, 192
 - certification level
 - SBU software, 172
 - SDU software, in 4w handset, 147
 - SDU software, MCDU view, 160
 - change PIN code, 137
 - channels
 - signal strength, 145
 - charges
 - SIP-enabled IP handset, 82
 - Classic Aero call
 - air to ground, 71
 - clearing logs, SBU, 180
 - clearing usage counter, SBU, 180
 - codec priority, 82
 - Comfort Noise, 121
 - commissioning, 24
 - conference call
 - MCDU, 93
 - SBU, 57
 - SDU, 42
 - configuration, 138
 - conformity, 217
 - connection
 - activate, 110
 - automatic shut down, 181
 - contact information, 189
 - contrast, LCD, 119
 - cordless phone, 13

D

dashboard, 170
data limit
 automatic shutdown, 181
data limits, 181
data sessions
 standard, SBU, 177
 streaming, SBU, 177
 viewing ongoing, SBU, 172
DDI numbers, 38
deactivation SMS, 186
default IP address, 106
delete
 known GES, 140
 known LES, 141
 phone book entry, SDU, 116
 preferred GES, 128
 preferred ISDN LES, 129
 preferred MPDS LES, 129
 Quick dial entry, Full Feature handset,
 135
 ring profile, 134
 satellite from list, 142
detailed navigation, 146
dial
 numbers in phone book, SBU, 53
dialing prefixes, SBU, 54
dialing restrictions, 187
Direct Dial-In, 38
directory, MCDU, 90
disable PIN code, 137
disclose position, 132
display, handset
 symbols, 64
display, MCDU, 83
 symbols, 84
DO-178B level, v, vi
DO-254D level, v, vi

document number
 related manuals, vi
 this manual, i
doppler velocity, 146

E

edit
 GES in known list, 141
 LES in known list, 142
 phone book, SDU, 116
 Quick dial entry, Full Feature handset,
 136
 satellite information, 142
EMERGENCY
 call priority, 150
error
 log, SDU, 148
 view active, SDU, 148
error codes, 190
 BITE, 191
 Cause codes, 191
 list of, 192
exchange
 local, 182
external IP address, 183

F

Fail/Pass LED
 HPA, 207
 SBU, 209
 SDU, 207
fault
 view active, SDU, 148
 view log, SDU, 148

- fax
 - how to use, SBU, 46
 - how to use, SDU, 34
- fax setup, 132
- fax type H+, select, 36
- fax type HSD, select, 36
- fax, H+ service, 21
- fax, sending or receiving, SBU, 60
- fax, sending or receiving, SDU, 44
- FCC compliance, 217
- features of AVIATOR 700, 4
- Flex key for options, 8
- forwarding calls, SBU, 58
- Full Feature cradle, 11
- Full Feature handset, 11
- function keys
 - Auxiliary handset, 74
 - Full Feature handset, 65
 - MCDU, 85

G

- G3 fax machine, 34, 46
- G4 fax or data, SBU, 46
- G4 fax or data, SDU, 34
- geostationary satellites, 15, 16
- GES, 18
 - list of known, 140
 - list of preferred, 128
 - priority, 128
- GPS Active, 146

H

- H+ fax, 21
- H+ modem, 21
- handset setup, 117
- handset type, 140

- heading, 146
- help desk number
 - changing in web interface, 198
- help desk number, SBU, 198
- holding a call, SBU, 56
- holding a call, SDU, 41
- HPA, 10
- HSD call
 - ground to air, 39
 - ISDN air to ground, 80

I

- ICAO address, 147
- IMEI number, 171
- IMN number, 39
- Inbox for SMS messages
 - replying, forwarding or deleting, 98
- incoming call
 - in MCDU display, 84
- Inmarsat, 15
- interfaces, 6
 - LAN and WLAN, SBU, 104
- internal calls, SBU, 52
- internal calls, SDU, 39
- Internet
 - connecting a PC, 101
- IP address
 - BGAN network, 183
 - default, 106
 - external, 183
 - for web interface, 167
 - local, viewing, 171
- IP handset, 12
 - SIP, 81
- IRS active, 146

-
- ISDN
 - local numbers, SBU, 53
 - local numbers, SDU, 40
 - phone call, 80
 - ISDN phone, 34
 - ISDN plug
 - SBU, 46
 - SDU, 34
 - ISN, 147

 - K**
 - key beep, 120
 - keys
 - Auxiliary handset, 74, 75
 - Full Feature handset, 65, 69
 - MCDU, 85

 - L**
 - LAN
 - managing network users, 104
 - LAN status, SDU, 147
 - latitude, 146
 - LCD, MCDU, 83
 - LEDs on SBU
 - Fail/Pass, 209
 - Logon, 208
 - Maintenance connector, 209
 - Power, 208
 - LEDs, handsets
 - Auxiliary handset, 73
 - Full Feature handset, 63
 - LEDs, system, 206
 - Fail/Pass, HPA, 207
 - Fail/Pass, SDU, 207
 - logon, SDU, 206
 - Power, HPA, 207
 - Power, SDU, 206
 - LES, 18
 - list of known, 141
 - list of preferred, ISDN, 129
 - list of preferred, MPDS, 129
 - priority, 129
 - light in handset, 119
 - limit
 - allowed MB, 181
 - data, 181
 - streaming class, 181
 - limit calls, 187
 - limiting data, 181
 - local call
 - MCDU, 90
 - SBU, 53
 - local exchange, 182
 - local numbers assigned, SBU, 53
 - local numbers assigned, SDU, 40
 - local phone call, SBU, 52
 - local phone call, SDU, 39
 - lock system
 - for one handset, 123
 - log
 - errors, SDU, 148
 - logoff, Full Feature handset, 126
 - logon
 - automatic, SDU, 126
 - custom, Full Feature handset, SDU, 125
 - Full Feature handset, SDU, 124
 - LED in handset, 64
 - LED on SDU, 206
 - manual with Full Feature handset,
-

- SDU, 125
 - policy, 128
 - settings, 126
- Logon LED
 - on SBU, 208
- logs, clearing, SBU, 180
- longitude, 146

M

- MAC address, 105, 171
- Maintenance connector
 - LED, 209
- manual
 - document number, i
- manuals
 - other, vi
- MCDU
 - display, 83
 - function keys, 85
 - making a call, 88
 - making or receiving a call, 87
- memory
 - Auxiliary handset, 76
- menu tree
 - SBU, 102
- menu, handset
 - accessing, 114
 - entering selected, 114
 - exiting, 114
 - scrolling through, 114
 - shortcuts, 114
 - tree, 212
- menu, MCDU
 - accessing, 86
 - navigating, 84
 - overview, 150
 - tree, 213

- messages
 - configuring outgoing, 99
 - forwarding, 98
 - opening in web interface, 98
 - receiving in web interface, 97
 - replying, 98
 - sending, 96
- missed calls, SBU, 177
- mobile numbers for SBU
 - viewing and editing, 175
- modem, H+ service, 21
- MPDS, 22
- multi-party call, SBU, 57
- Multi-voice, 175

N

- navigation
 - data, 146
 - show detailed, 146
 - speed, 146
- navigation in web interface, 169
- Navigation source, 146
- Network Coordination Stations (NCS), 15
- network management, 104
- network user group, 105
- NON-SAFETY
 - call priority, 150
- non-safety interfaces, 8
- Normal User, 114
 - PIN code, 136
- numeric keys
 - Auxiliary handset, 75

O

- Outbox for SMS messages
 - resending or deleting messages, 95
- outgoing calls, SBU, 177
- override
 - call type, SBU, 47

P

- packet data
 - H+, 22
 - high speed, 22
- password
 - SIP phone, 82
- PC
 - connecting to the Internet, 101
- phone
 - how to use, SBU, 46
 - how to use, SDU, 34
 - local call, SBU, 52
 - local call, SDU, 39
 - making calls, SBU, 49
 - making calls, SDU, 37
- phone book, 173
 - delete entry, SDU, 116
 - edit entry, SDU, 116
 - Full Feature handset, making a call, 72
 - insert new entry, SDU, 116
 - limited numbers, 187
 - making a call, SDU, 116
- phone book, MCDU, 90
- phone book, SBU
 - adding number, 174
 - deleting all entries, 175
 - deleting an entry, 174
 - modifying an entry, 174

- phone book, SDU, 115
- phone number, 175
- phone numbers for SBU, 175
- phone volume, 121
- Phone/Fax interface
 - local numbers, SDU, 40
 - local, SBU numbers, 53
- PIN code
 - normal, 136
 - Service, 136
 - Super, 136
- PIN codes
 - changing, 137
- pitch, 146
- POTS phone, 73
- Power LED
 - HPA, 207
 - on SBU, 208
 - SDU, 206
- prefixes, special-purpose, SBU, 54
- priority
 - change for GES, 128
 - change for ISDN LES, 129
 - change for MPDS LES, 129
 - of phone numbers, MCDU, 90
- profiles, 104
- properties
 - system, 171
- Proxy server, disabling, 165
- PUBLIC
 - call priority, 150

Q

- quality of voice, 34, 46

- Quick dial
 - edit entry, Full Feature handset, 136
 - Full Feature handset, 135
 - making a call, Full Feature handset, 72
- Quick dial, SBU, 49

R

- radiation warning, iii
- Realm, 82
- received calls, SBU, 177
- redial
 - Auxiliary handset, 78
 - Full Feature handset, 72
 - SBU, 53
- reduce airtime cost, 107
- remote activation
 - by SMS, 186
 - trusted mobile number, 186
- remote control, 185
- remote management
 - accessing, 184
 - preparation, 183
 - SBU, 183
- reset, 148
- restricted dialing, 187
- ring profile
 - defining, 133
 - selecting, 122
- ring tone
 - all handsets, 120
 - broadcast call, 120
 - current handset, 120
 - direct call, 120
- ring volume, 121

- ringmode
 - defining, 133
 - selecting, 122
- roll, 146
- router functionality, 8

S

- SAFETY
 - call priority, 150
 - safety summary, iii
- SATCOM MAIN, 86
- SATCOM subsystem, 86
- satellite
 - view selected, 171
- satellites
 - footprint, 16
 - Inmarsat, 15, 16
 - list of, 142
- SBU
 - accessing the web interface, 167
 - remote control, 183
- Scratch Pad
 - MCDU, 83
- SDU, 9, 34
 - serial number, 147
- SDU errors, 190
- seat-to-seat
 - dialing, SBU, 53
- sent messages
 - resending, forwarding or deleting, 96
 - viewing status, 96
- serial number, 171
- serial numbers
 - viewing, 147
- Server name
 - SIP server, 82
- service log, 190

- Service Provider, 114
 - PIN code, 136
- services
 - view availability, 145
- services supported, 21
- Short dial, SBU, 49
- Sigma7
 - handset and cradle, 12
- signal strength, 145
- Silent function, 119
- SIP client, 81
- SIP server
 - codec priority, 82
 - connect to, 81
 - name, 82
 - password, phone, 82
 - realm, 82
- SIP-enabled IP handset
 - server name, 81
 - setting up, 81
 - using, 82
- site map
 - SBU web interface, 102
- SMS
 - activation, 186
 - deactivation, 186
- SMS activation, 186
- SMS in web interface
 - forwarding, 98
 - opening, 98
 - receiving, 97
 - replying to, 98
 - sending, 96
- SMS service center
 - number, 99, 100
- software
 - viewing version, 171
- software version, v, 147
 - SBU Level D, vi
 - SBU Level E, v
 - SBU software, 172
 - SDU Level D, vi
 - SDU Level E, v
 - SDU, 4w handset view, 147
 - SDU, MCDU view, 160
- speaker volume, 121
- special characters, 69
- Speech, 22
- spot-beams, 16
- Standard data
 - activating, 110
- standard data sessions, SBU, 177
- Standard IP
 - activate, 110
- Standard IP data connection, 109
- standard voice
 - phone number, 175
- status, 143
 - ongoing calls and data sessions, SBU, 172
 - viewing, 170
- storing a phone number
 - Auxiliary handset, 76
- streaming class
 - time limit, 181
- streaming connection
 - stop, 112
- streaming data sessions, SBU, 177
- Streaming IP data, 109
- streaming rates, 111
- Super User, 114
 - PIN code, 136
- supplementary services, SBU, 55
- support
 - contact information, 189
- SW version, 147

Swift64 data connection, 112
SWIFT64 numbering, 39
Swift64 service, 16
switchboard, MCDU, 91
system reset, 148
system setup, 130

T

TCP/IP traffic, 109
telephone interface
 local numbers, 53
 local numbers, SDU, 40
To, 173
tools for setting up the SBU, 101
total usage
 viewing, SBU, 172
total usage, SBU calls
 viewing, 176
transferring a call
 Full Feature handset, 41
 SBU, 57
troubleshooting, 190
troubleshooting guide, 200
trusted mobile number, 186
typography used in this manual, vi

U

usage counter
 clearing, SBU, 180
usage counter, SBU, 172
usage counter, SBU calls, 176
user interfaces, 101
user name
 SIP server, 82

V

version of software, 171
voice
 H+, 21
 HSD, 22
voice mail, 30
 number, 99
 number, SBU, 178
voice mail for SBU, 52
voice quality, 34, 46
volume
 phone, 121

W

waiting calls, SBU, 55
warning
 radiation, iii
web interface, 14
 accessing, 164
 browser settings, 165
 navigating, 169
Wireless, 8
Wireless Handset and Cradle, 12
wireless IP handset, 81
WLAN option, 8
world map with satellites, 17

