



Middleby Cooking Systems Group • 1400 Toastermaster Drive • Elgin, IL 60120 • (847)741-3300 • FAX (847)741-4406

Conveyor Toaster

Models TC14, TC18

OWNER'S OPERATING AND INSTALLATION MANUAL

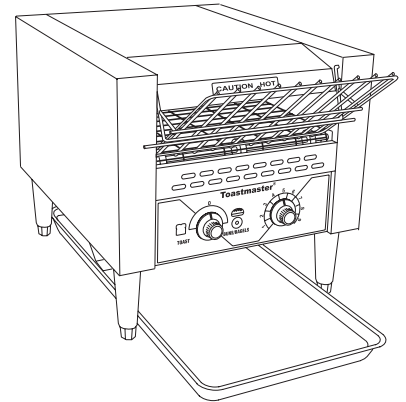

© 1999 Toastermaster, A Middleby Company.

Toastermaster is a registered trademark of Toastermaster, A Middleby Company. All rights reserved.

I. DESCRIPTION AND SPECIFICATIONS

A. Component Location

The major components of the toaster are shown in Figure 1 below.

Figure 1

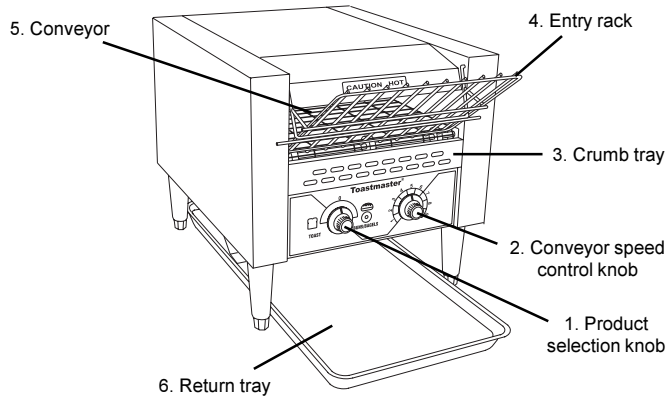

B. Component Function (see Figure 1)

- 1-2. Toaster control knobs - see Section III, **Operation**.
3. Crumb tray - Collects crumbs from the toasted product. The tray can be removed for cleaning.
4. Entry rack - Loaded with the bakery product to be toasted. The product then slides onto the conveyor. The entry rack can be removed for cleaning.
5. Conveyor - Transports the bakery product through the toaster, between the top and bottom heating elements.
6. Return tray - Collects the toasted product. The tray can be removed for cleaning.

C. Operating and Electrical Specifications

Pre-Heat Time: 20 minutes

Electrical Specifications/TC14 toaster models:

- 120V, 50/60 Hz, 1 Ph, 1.7kW, 14.3A, NEMA 5-20P plug
- 208V, 50/60 Hz, 1 Ph, 2.1kW, 10.2A, NEMA 6-15P plug
- 240V, 50/60 Hz, 1 Ph, 2.1kW, 8.8A, NEMA 6-15P plug

Electrical Specifications/TC18 toaster models:

- 208V, 50/60 Hz, 1 Ph, 2.65kW, 12.8A, NEMA 6-20P plug
- 240V, 50/60 Hz, 1 Ph, 2.65kW, 11.1A, NEMA 6-20P plug

NOTE

Electrical wiring diagrams are provided at the back of this Manual.

WARNING: IN CASE OF FIRE

Disconnect the toaster from its power source IMMEDIATELY. This allows the unit to cool, making it easier to put out the fire.

WARNING

FOR YOUR SAFETY DO NOT STORE OR USE GASOLINE OR OTHER FLAMMABLE VAPORS OR LIQUIDS IN THE VICINITY OF THIS OR ANY OTHER APPLIANCE

WARNING

IMPROPER INSTALLATION, ADJUSTMENT, ALTERATION, SERVICE OR MAINTENANCE CAN CAUSE PROPERTY DAMAGE, INJURY OR DEATH. READ THE INSTALLATION AND OPERATING INSTRUCTIONS THOROUGHLY BEFORE INSTALLING OR SERVICING THIS EQUIPMENT.

WARNING

DO NOT OPERATE THE CONVEYOR TOASTER ON EITHER OF ITS SIDES, ON ITS REAR SURFACE, OR WITHOUT LEGS. PREMATURE FAILURE OF THE HEATING ELEMENTS WILL OCCUR.

WARNING

DISCONNECT THE TOASTER FROM ITS ELECTRICAL POWER SUPPLY BEFORE CLEANING OR SERVICING.

CAUTION

Using any parts other than genuine Toastermaster factory parts relieves the manufacturer of all liability.

IMPORTANT

Contact your authorized service agent to perform maintenance and repairs. A service agency directory is supplied with your toaster.

IMPORTANT

Toastermaster (manufacturer) reserves the right to change specifications and product design without notice. Such revisions do not entitle the buyer to corresponding changes, improvements, additions or replacements for previously purchased equipment.

RETAIN THIS MANUAL FOR FUTURE REFERENCE

This manual provides detailed information for the installation and operation of your toaster. It also contains information to assist the operator in diagnosing problems in the event of a malfunction. This manual is an important tool for the operator and should be kept readily available.

II. INSTALLATION

IMPORTANT

IT IS THE CUSTOMER'S RESPONSIBILITY TO REPORT ANY CONCEALED OR NON-CONCEALED DAMAGE TO THE FREIGHT COMPANY.

A. Assembly

1. Thread the 4" (102mm) legs into the four holes on the bottom of the toaster. See Figure 2. Then, place the toaster in the desired location.
2. Install the entry rack and crumb tray into the front of the toaster, as shown in Figure 2.

Figure 2 - Basic assembly and front-exit configuration

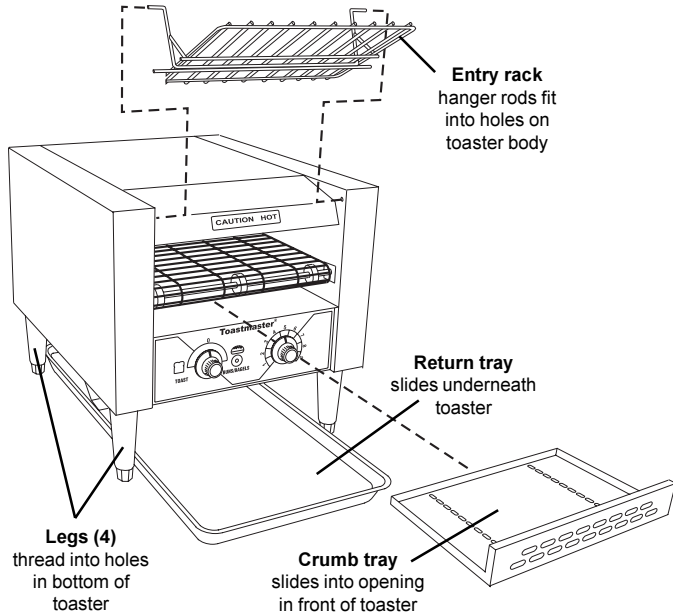

3. TOASTERS INTENDED FOR FRONT-EXIT OPERATION ONLY:
Position the return tray underneath the toaster, as shown in Figure 2. Note that the return tray extends past the FRONT of the toaster during front-exit operation.
4. TOASTERS INTENDED FOR "STRAIGHT-THROUGH," REAR-EXIT OPERATION ONLY:
 - Remove the CENTER screw from the rear panel of the toaster, as shown in Figure 3.
 - Push the rear panel forward into the toaster.
 - Position the return tray underneath the toaster as shown in Figure 3. Note that the return tray extends past the REAR of the toaster during rear-exit operation.

Figure 3 - Electrical connection and rear-exit configuration

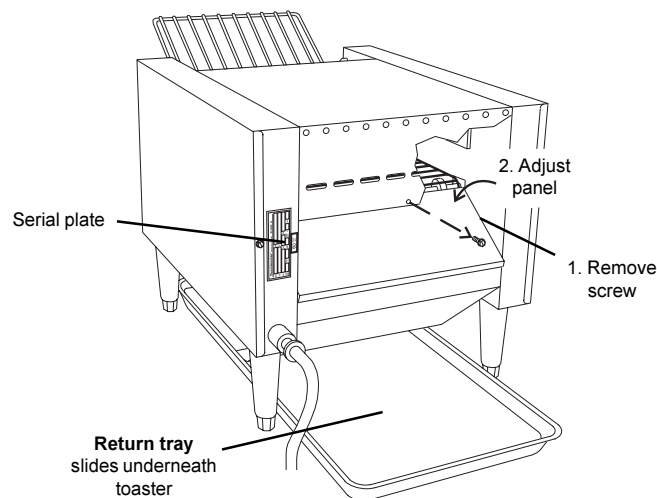

B. Electrical Utility Connection

IMPORTANT

THE ELECTRICAL CONNECTION TO THE TOASTER REQUIRES A CIRCUIT BREAKER/FUSED DISCONNECT. ELECTRICAL SPECIFICATIONS ARE LISTED ON THE SERIAL PLATE (SHOWN IN FIGURE 3), AND IN THE ELECTRICAL SPECIFICATIONS ON PAGE 1 OF THIS MANUAL.

CONSULT ALL APPLICABLE NATIONAL AND LOCAL CODES FOR FURTHER ELECTRICAL CONNECTION REQUIREMENTS.

1. Before proceeding with the electrical connection, check the following:
 - a. Check that the electrical supply matches the toaster's requirements. Refer to the toaster's serial plate (Figure 3) and to the Electrical Specifications on Page 1.
 - b. Check that the appropriate receptacle is available for the power cord plug.



WARNING

ENSURE THAT BOTH THE CIRCUIT BREAKER/FUSED DISCONNECT AND THE PRODUCT SELECTION KNOB ARE IN THE OFF ("0") POSITION BEFORE PROCEEDING.



WARNING

ENSURE THAT ANY PACKING MATERIAL RESIDUE HAS BEEN REMOVED FROM INSIDE THE TOASTING CHAMBER.

3. Insert the power cord plug into its receptacle.

III. OPERATION

A. Location and Function of Controls

This section provides a basic description of the toaster controls, their location, and the functions they perform. The operator MUST be familiar with the controls. Refer to Figure 4.

Figure 4

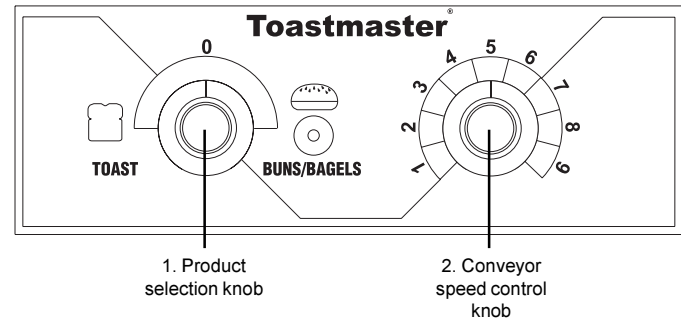

1. Product Selection knob

- When set to TOAST (☞), switches on the conveyor, the upper heating element, and one lower heating element.
- When set to OFF ("0"), switches off the conveyor and all heating elements.
- When set to BUNS/BAGELS (☉), switches on the conveyor and both of the lower heating elements.

2. Conveyor Speed Control knob

Adjusts the speed of the conveyor. This controls the amount of toasting that the bakery product receives.

- "1" is the minimum speed setting, which produces a darker toasting of the bakery product.
- "9" is the maximum speed setting, which produces a lighter toasting of the bakery product.

B. Operation Procedure

1. Restore electrical power to the toaster at the circuit breaker/fused disconnect.
2. Switch the Product Selection knob to either TOAST (🍞) or BUNS/BAGELS (🥨), depending on the product to be toasted.
3. Allow the toaster to pre-heat for at least 20 minutes.
4. Adjust the toasting time (if necessary) by turning the conveyor speed control knob.
5. Load the entry rack with the bakery product to be toasted. The product will slide off the entry rack and onto the conveyor.

IMPORTANT

If the Product Selection knob is set to BUNS/BAGELS (🥨), load the bakery product **CUT SIDE DOWN** for proper toasting. Refer to Figure 5.

6. After toasting, remove the product from the return tray.
7. During inactive periods, switch the Product Selection knob to the BUNS/BAGELS (🥨) position. This leaves only the lower heating elements on, allowing a quicker recovery to normal toasting temperatures.

Figure 5

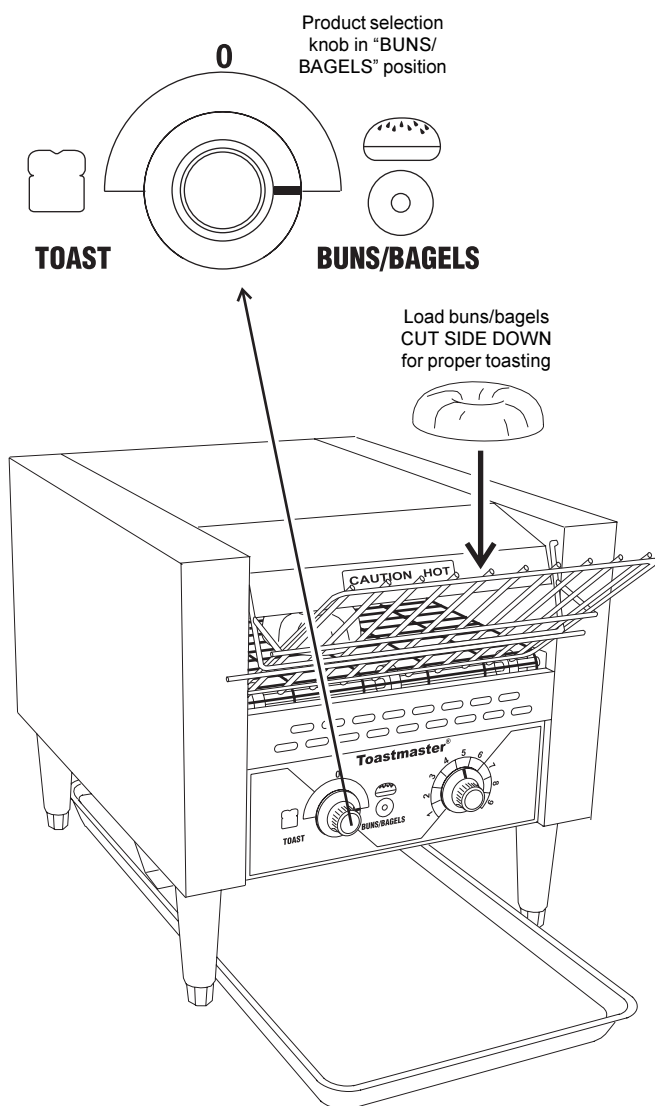

C. Shutdown Procedure

1. Switch the Product Selection knob to the OFF ("O") position.
2. Disconnect electrical power to the toaster at the circuit breaker/fused disconnect.
3. Allow the toaster to cool.

D. Clearing Jams



WARNING

NEVER INSERT YOUR HANDS INTO THE TOASTING CHAMBER TO CLEAR A JAM. SERIOUS INJURY MAY RESULT.

CAUTION

NEVER use a plastic object to clear a jam. If the toaster is not completely cool, damage to the toaster may result.

CAUTION

When clearing a jam, use care to avoid damaging the heating elements.

1. Switch the Product Selection knob to the OFF ("O") position.
2. Disconnect electrical power to the toaster at the circuit breaker/fused disconnect.
3. Allow the toaster to cool.



CAUTION - HOT SURFACES

DO NOT ATTEMPT TO CLEAR THE JAM UNTIL THE TOASTER HAS COOLED THOROUGHLY.

4. Carefully clear the jam using a long object as a probe. This object should preferably be made of wood, which is less likely to damage the heating elements.

E. Daily Cleaning



WARNING

WHEN CLEANING THE TOASTER, NEVER APPLY ENOUGH LIQUID TO STAND IN PLACE ON THE UNIT. DO NOT SPRAY, RINSE, OR SUBMERGE THE TOASTER. EXCESSIVE MOISTURE IN THE UNIT WILL CAUSE A SEVERE ELECTRICAL HAZARD AND MAY OTHERWISE DAMAGE THE TOASTER.

CAUTION

DO NOT clean your toaster using abrasive cleaners or pads. Both will scratch and dull the finish.

1. With the conveyor running, use a brush to clean any crumbs off the conveyor into the crumb tray.
2. Switch the Product Selection knob to the OFF ("O") position.
3. Disconnect electrical power to the toaster at the circuit breaker/fused disconnect.
4. Allow the toaster to cool.



CAUTION - HOT SURFACES

DO NOT TOUCH HOT SURFACES ON THE TOASTER, OR REACH INTO THE TOASTING CHAMBER, UNTIL THE UNIT HAS COOLED THOROUGHLY.

5. Wipe the exterior of the toaster with a sponge or cloth soaked in hot or warm detergent water. Wipe with a clean, damp cloth to remove the excess detergent, and then wipe again to dry the toaster.
6. Remove the crumb tray and the return tray from the toaster, and empty them. Wash the trays in warm detergent water, and rinse them.

CAUTION

Never remove the crumb tray while the conveyor is moving.

7. Remove the entry rack from the toaster. Wash the rack in warm detergent water, and rinse it.
8. Towel the trays and entry rack dry. Reassemble all parts onto the toaster.

Wiring Diagram Model TC14 120V Toasters

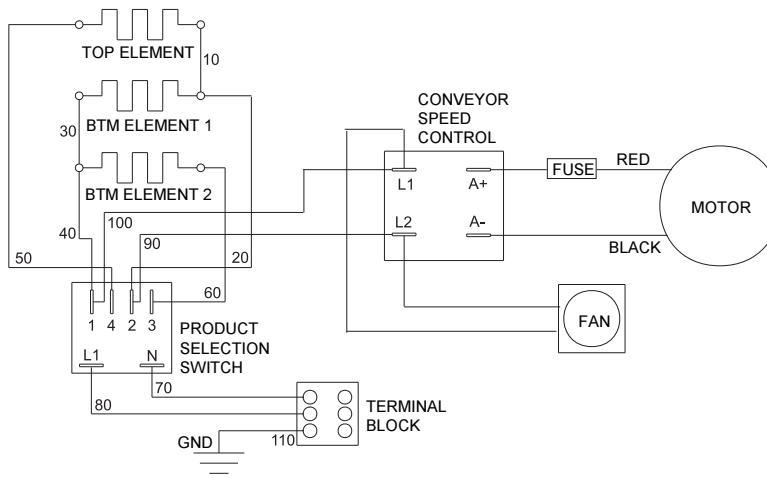

Wiring Diagram Model TC14 208V and 240V Toasters

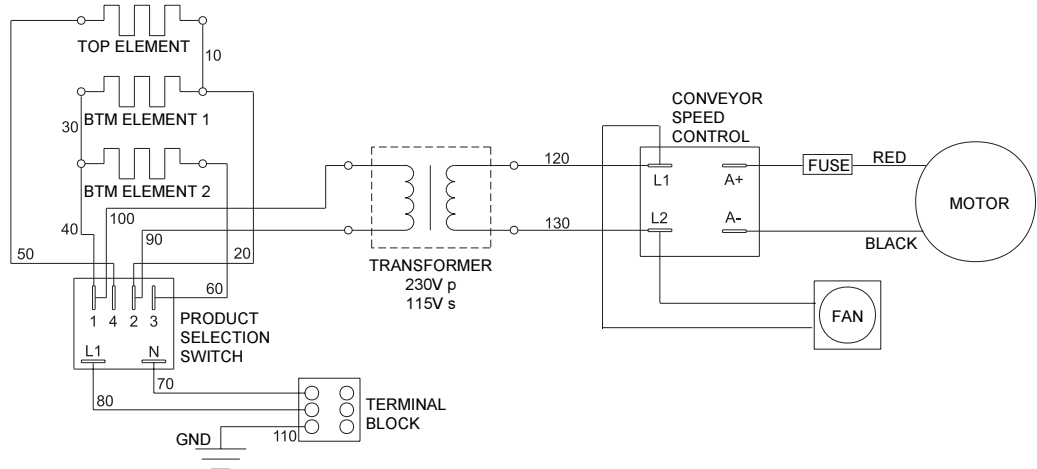

Wiring Diagram Model TC18 208V and 240V Toasters

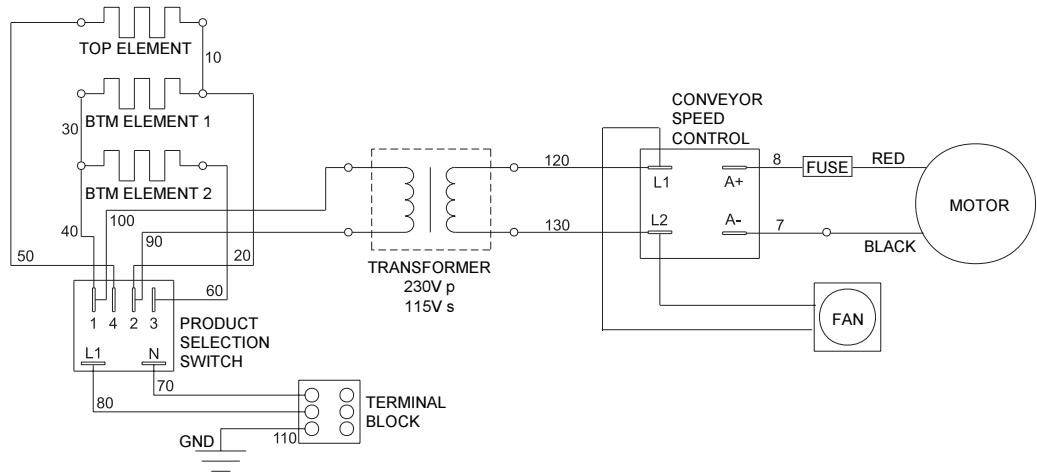

Switch Configuration All Model TC14 and TC18 Toasters

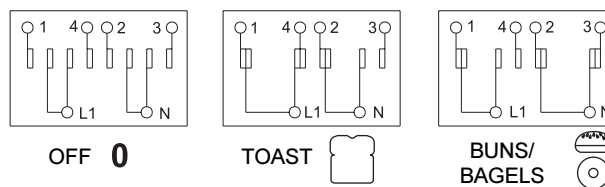

Toastmaster®

A Middleby Company

Toastmaster • 1400 Toastmaster Drive • Elgin, IL 60120 • USA • (847)741-3300 • FAX (847)741-4406

Middleby Corp 24-Hour Service Hotline 1-800-238-8444

www.middleby.com