

Tobii Dynavox I-Series User's Manual

I-110

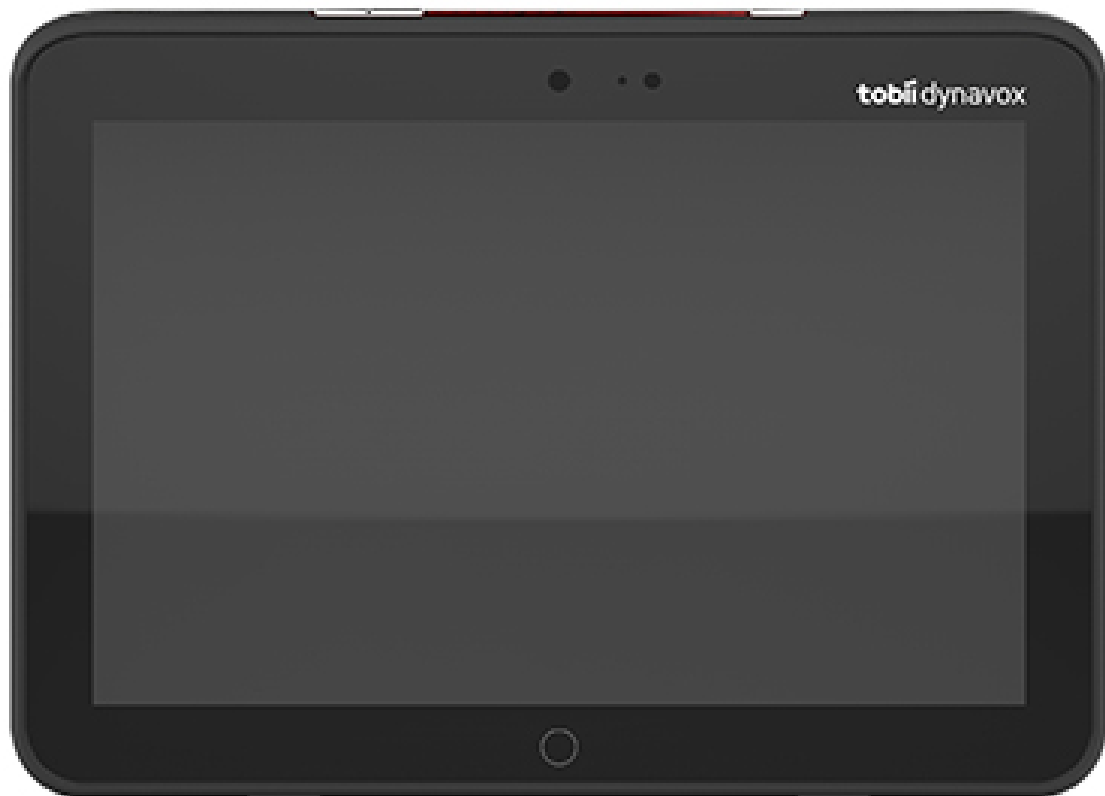

tobii dynavox

User's manual Tobii Dynavox I-Series

Version 1.0

05/2017

All rights reserved.

Copyright © Tobii AB (publ)

No part of this document may be reproduced, stored in a retrieval system, or transmitted in any form, by any means (electronic, photocopying, recording, or otherwise) without the prior written permission of the publisher.

Copyright protection claimed includes all forms and matters of copyrightable material and information allowed by statutory or judicial law or hereafter granted, including without limitation, material generated from the software programs which are displayed on the screen such as screen displays, menus, etc.

The information contained in this document is proprietary to Tobii Dynavox. Any reproduction in part or whole without prior written authorization by Tobii Dynavox is prohibited.

Products that are referred to in this document may be either trademarks and/or registered trademarks of the respective owners. The publisher and the author make no claim to these trademarks.

While every precaution has been taken in the preparation of this document, the publisher and the author assume no responsibility for errors or omissions, or for damages resulting from the use of information contained in this document or from the use of programs and source code that may accompany it. In no event shall the publisher and the author be liable for any loss of profit or any other commercial damage caused or alleged to have been caused directly or indirectly by this document.

Content subject to change without notice.

Please check Tobii Dynavox web site www.TobiiDynavox.com for updated versions of this document.

Table of Contents

| | | |
|----------|---|-----------|
| 1 | Introduction..... | 5 |
| 1.1 | Explanation of Admonitions..... | 5 |
| 1.2 | Symbols and Markings..... | 5 |
| 1.3 | Intended Use..... | 6 |
| 1.3.1 | Portable Use..... | 7 |
| 1.3.2 | Mounted Use..... | 7 |
| 1.4 | Package Contents..... | 7 |
| 1.4.1 | Tobii Dynavox I-Series..... | 7 |
| 2 | Safety..... | 9 |
| 2.1 | Avoiding Hearing Damage..... | 9 |
| 2.2 | Temperature..... | 9 |
| 2.3 | Power Supply and Batteries..... | 10 |
| 2.4 | Mounting..... | 10 |
| 2.5 | Emergency..... | 11 |
| 2.6 | Electricity..... | 11 |
| 2.7 | Child Safety..... | 11 |
| 2.8 | Software..... | 11 |
| 2.9 | Magnetic Field..... | 11 |
| 2.10 | Third Party..... | 11 |
| 2.11 | Environmental Control..... | 11 |
| 3 | Overview of the I-110..... | 12 |
| 3.1 | Key Features..... | 12 |
| 3.2 | Product Layout..... | 12 |
| 3.2.1 | Ports, Sensors and Device Buttons..... | 13 |
| 3.3 | Preinstalled Software..... | 14 |
| 4 | Batteries in the Tobii Dynavox I-Series..... | 15 |
| 4.1 | Batteries..... | 15 |
| 4.2 | Charging the Tablet..... | 15 |
| 4.2.1 | LED Behavior..... | 15 |
| 5 | Using the Tobii Dynavox I-Series..... | 16 |
| 5.1 | Starting the Device..... | 16 |
| 5.1.1 | First Start Up..... | 16 |
| 5.1.2 | Password Information..... | 16 |
| 5.1.3 | The Discover Tobii Dynavox app..... | 16 |
| 5.2 | Shutting Down the Tobii Dynavox I-Series..... | 16 |
| 5.3 | Power Saving..... | 17 |
| 5.3.1 | Turn Off/On the Screen..... | 17 |
| 5.4 | Using the Cameras..... | 17 |
| 5.5 | Adjusting the Volume..... | 17 |
| 5.6 | Adjusting the Sound..... | 17 |
| 6 | Product Care..... | 18 |
| 6.1 | Temperature & Humidity..... | 18 |
| 6.1.1 | General Use - Operating Temperature..... | 18 |
| 6.1.2 | Transportation and Storage..... | 18 |
| 6.2 | Cleaning..... | 18 |
| 6.2.1 | Cleaning of the Speakers..... | 18 |

| | | |
|-------------------|--|-----------|
| 6.3 | Placement | 18 |
| 6.4 | Transporting the Tobii Dynavox I-Series Device | 18 |
| 6.5 | Disposing of the Tobii Dynavox I-Series Device | 18 |
| Appendix A | Support, Warranty, Training Resources | 19 |
| A1 | Customer Support..... | 19 |
| A2 | Warranty | 19 |
| A3 | Training Resources..... | 19 |
| Appendix B | Compliance Information | 20 |
| B1 | FCC Statement..... | 20 |
| | B1.1 For P15B Equipment | 20 |
| | B1.2 For Portable Devices | 20 |
| B2 | Radio Wave Exposure and Specific Absorption Rate (SAR) Information | 20 |
| B3 | Industry Canada Statement | 21 |
| B4 | CE Statement | 21 |
| B5 | Standards | 21 |
| B6 | IECEE CB Scheme | 22 |
| Appendix C | Maximum Allowed Temperature | 23 |
| Appendix D | Technical Specifications | 24 |
| D1 | Tobii Dynavox I-Series Device | 24 |
| D2 | Power Adapter..... | 25 |
| Appendix E | Approved Accessories | 26 |

1 Introduction

Thank you for purchasing a Tobii Dynavox I-Series device from Tobii Dynavox!

To ensure the optimal performance of this product, please take the time to read this manual carefully.

The Tobii Dynavox I-Series is a Tobii Dynavox Speech Generating Device intended for use as an augmentative communication aid, for computer access, and as an environmental control unit for those with speech, language, physical, and cognitive disabilities.

1.1 Explanation of Admonitions

In this manual we use four (4) levels of admonitions as follows:



Is used for notifying the user of something important or of something that needs special attention.



Is used to inform of something that could cause harm to, or malfunction of, the equipment.









Is used to inform of something in which there is a conceivable risk of harm to the user if the Warning is ignored.



Is used to inform of something that can cause damage to hearing.

1.2 Symbols and Markings

This section provides information about the symbols that are used on the Tobii Dynavox I-Series, its accessories, or packaging.

| Symbol or Markings | Description |
|---|--|
|  | Dispose of in accordance with your country's requirements. |
|  | CE is the abbreviation of the European Communities and this mark tells customs officials in the European Union that the product complies with one or more of the EC Directives |
|  | This mark is a certification mark employed on electronic products manufactured or sold in the United States which certifies that the electromagnetic interference from the device is under limits approved by the Federal Communications Commission. |
|  | Conforms to relevant Australian EMC requirements |
|  | Dispose of in accordance with your country's requirements. |
|  | Safety Class II equipment (reinforced insulation). |
|  | Recognized component mark for Canada and the United States. |

| Symbol or Markings | Description |
|--------------------|---|
| | The most recognized International Safety mark. This safety listing signifies that the product was tested to IEC 60601-1. |
| | For indoor use only. |
| | This mark show the pin out polarity on the AC/DC Power Adapter. |
| | Mark indicating a power supply meets the level V requirements at both 115 V/60 Hz and 230 V/50 Hz, if designed to operate at multiple input voltages. Products with a nameplate marked for only one voltage and frequency should also use this mark assuming the product meets the performance requirements; in other words, manufacturers do not have to indicate the voltage with the mark. |
| | USB 3.0 Port |
| | DC Power connector |
| | Head phone jack 3,5 mm |
| SW1 | 3.5 mm Switch port 1 |
| SW2 | 3.5 mm Switch port 2 |

1.3 Intended Use

Tobii Dynavox I-Series is a dedicated Speech Generating Device (SGD), primarily designed to serve as an augmentative and alternative communication (AAC) aid. Secondly, Tobii Dynavox I-Series will also provide its users with alternative computer access, long distance communication and environmental control.

The target users for Tobii Dynavox I-Series are individuals with physical and/or cognitive conditions affecting their ability to speak, communicate and participate in everyday activities. Tobii Dynavox I-Series provides these users with a way to communicate that is appropriate for their age, cognitive level, language skills, and physical abilities. This might be through Visual Scene Displays (VSDs), grid-based symbol pages, keyboards, or a combination of the above. Composed messages are communicated through recorded voice or synthesized speech.

Tobii Dynavox I-Series is built to serve a wide range of input method needs and use cases. The typical user will be ambulatory and interact with the device through touch. The device is also appropriate for physically disabled users that require alternative access methods, such as switch scanning, or wheelchair mounting. Tobii Dynavox I-Series is based on Windows 10 and is available both in dedicated and open configurations. In the dedicated configuration, Tobii Dynavox I-Series will restrict the users from access to features that are not seen as communication functionality.

In addition to providing users with face-to-face communication possibilities, Tobii Dynavox I-Series also facilitates alternative access to a number of computer access and long distance communication features. The device has built-in WLAN and cellphone connectivity through Bluetooth. Tobii Dynavox I-Series also has built-in infrared transmitters enabling the user to control TV, lights, blinds and other IR-compatible devices in their environment.

Tobii Dynavox I-Series is a medical device designed to meet the requirements of EN-60601 and all other regulatory requirements in the markets where it is sold. The Tobii Dynavox I-Series is significantly more rugged than typical consumer tablets, and comes with an IP54 ingress protection, enabling use in most conditions. Tobii Dynavox I-Series is not intended to be the user's sole means of communication. Users should have an alternative, low-tech communication method in the event that the device is malfunctioning or otherwise inaccessible.



The Tobii Dynavox I-Series device does not sustain or support life.

In case of failure of the Tobii Dynavox I-Series device, the user cannot communicate using it.



Intended use is both indoor and outdoor conditions.

1.3.1 Portable Use

A portable Tobii Dynavox I-Series can be hand-held used, and in two (2) different positions as the examples below

- Standing
- Resting

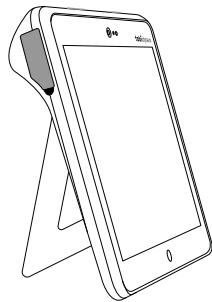

Standing

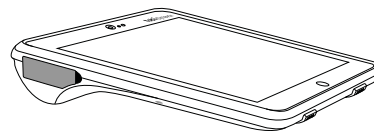

Resting

Through the built-in stand, the I-110 can be used standing on a flat surface. By collapsing the stand, the device can also be used in a resting position, either resting on a surface or handheld. By utilizing the included carry strap, the device can also be carried around the user's neck. Both positions allow for touch input, scanning or other alternative input methods.

1.3.2 Mounted Use

The Tobii Dynavox I-Series can be mounted on to several mounting systems.

- ConnectIT
- REHAdapt
- Daessy

1.4 Package Contents



It is recommended to keep the original packaging materials for the Tobii Dynavox I-Series.

If device needs to be returned to Tobii Dynavox for Warranty related issues or repair, it is beneficial that the original packaging or equal equivalent is used for shipping. Most shipping carriers require at least 2 inches of packing material around the device.

Please note: Due to Joint Commission regulations, any shipping materials including boxes sent to Tobii Dynavox must be discarded.

1.4.1 Tobii Dynavox I-Series

The items below are included with your Tobii Dynavox I-Series package:

- 1 Tobii Dynavox I-Series Device
- 1 Power Supply for the Tobii Dynavox I-Series device
- 1 Carry Strap
- 1 Windows 10 license (license sticker on device)
- The following Tobii Dynavox Communication software:
 - Tobii Dynavox Snap (pre-installed)
 - Tobii Dynavox Communicator 5 (pre-installed)
- 1 Tobii Dynavox Snap Scene (pre-installed)
- 1 Tobii Dynavox ALL (Pre-installed)
- 1 Tobii Dynavox I-Series User's Manual (on the device as a PDF document)
- 1 Tobii Dynavox I-Series Quick Start Manual (printed)
- 1 Safety and Compliance document (printed)
- 1 Warranty Document (printed)

2 Safety

The Tobii Dynavox I-Series device has been tested and approved as compliant to all the Specifications and Standards listed in *Appendix B Compliance Information, page 20* of this manual and in the *Appendix D Technical Specifications, page 24*. Nevertheless, in order to ensure safe operation of your Tobii Dynavox I-Series device, there are a few safety warnings to bear in mind:



No modification of this equipment is allowed



The Tobii Dynavox I-Series is not to be used as a life supporting Device, and it shall not be relied on in case of loss of function due to power loss or other causes.



There could be a choking hazard risk if small parts detach from the Tobii Dynavox I-Series device.



The Tobii Dynavox I-Series device is designed to meet a high ingress protection rating, meaning it will withstand light rain or snow. However, it shall not be exposed to or used in heavy rain or weather conditions outside the Technical Specification of the Tobii Dynavox I-Series device.



The Tobii Dynavox I-Series device shall only be used with Tobii Dynavox I-Series specific Accessories that have a mounting instruction included with the accessory.



Young children or people with cognitive disabilities should not have access to, or the use of, the Tobii Dynavox I-Series device without parental or guardian supervision.



The Tobii Dynavox I-Series device is designed to be rugged and durable. It shall still be handled and used with care when moving around.

2.1 Avoiding Hearing Damage



Permanent hearing loss may occur if earphones, headphones or speakers are used at high volume. To prevent this, the volume should be set to a safe level. You can become desensitized over time to high sound levels which may then sound acceptable, yet still could be damaging your hearing. If you experience symptoms such as ringing in your ears, please lower the volume or stop using the earphones/headphones. The louder the volume, the less time is required before your hearing could be affected.

Hearing experts suggest the following measures to protect your hearing:

- Limit the amount of time you use earphones or headphones at high volume.
- Avoid turning up the volume to block out noisy surroundings.
- Turn the volume down if you cannot hear people speaking near you.

To establish a safe volume level:

- Set your volume control at a low setting.
- Slowly increase the sound until you can hear it comfortably and clearly, without distortion.

2.2 Temperature



Due to use in direct sunshine or in any other hot environment the Tobii Dynavox I-Series device may have hot surfaces. There is a built in temperature sensor that monitors the temperature. If the sensor detects temperatures above the temperature specified in *Table C.1 Maximum Allowed Hotspot Temperature, page 23* the device will automatically trigger a Windows Shut Down to not cause the User any risk of harm. It may take a while before Tobii Dynavox I-Series device can be restarted as the unit may first need time to cool down.

2.3 Power Supply and Batteries



The Tobii Dynavox I-Series device contains a rechargeable battery. All rechargeable batteries degrade over time. Thus the possible usage times for the Tobii Dynavox I-Series after a full charge can become shorter over time than when the device was new.



The Tobii Dynavox I-Series device uses a Li-ion Polymer battery.

If you are in a hot environment, be aware that it can affect the ability to charge the battery. The internal temperature has to be between 0 °C/32 °F and 45 °C/113 °F for the battery to charge. If the internal battery temperature raises above 45 °C/113 °F the battery will not charge at all.

Move the Tobii Dynavox I-Series device to a cooler environment to let the battery charge properly.



Avoid exposing the Tobii Dynavox I-Series device to fire or to temperatures above 60 °C/140 °F. These conditions may cause the battery to malfunction, generate heat, ignite or explode. Be aware that it is possible, in a worst case scenario, for temperatures to reach greater than those stated above in, for example, the trunk of a car on a hot day. So, storing the Tobii Dynavox I-Series device, in a hot car trunk could conceivably lead to a malfunction.



Only charge the Tobii Dynavox I-Series battery in an ambient temperature of 0 °C/32 °F to 45 °C/113 °F.



Use only the supplied power adapter to charge the Tobii Dynavox I-Series device. Using unauthorized power adapters may severely damage the Tobii Dynavox I-Series device.



Do not open, or modify, the casing of the Tobii Dynavox I-Series device or of the power supply, since you may be exposed to potentially hazardous electrical voltage. The device contains no serviceable parts. If the Tobii Dynavox I-Series device or it's accessories are mechanically damaged, **do not to use them**.



If the battery are not charged or the Tobii Dynavox I-Series is not connected to the power supply, the Tobii Dynavox I-Series device will shut down.



If the Power Supply Cord is damaged it needs to be replaced by Service Personnel only. Do not use the Power Supply Cord until replaced.



Only connect the Tobii Dynavox I-Series to the Power adapters shipped with this device.



The appliance coupler of the power supply is used as the Mains Disconnection Device, please do not position the Tobii Dynavox I-Series device so that it is difficult to operate the disconnection device.



Special regulations apply to shipping devices containing Li-ion Polymer batteries. If dropped, crushed, or short-circuited, these batteries can release dangerous amounts of heat and may ignite, and are dangerous in fires.

Please reference IATA regulations when shipping lithium metal or lithium ion batteries or cells: http://www.iata.org/whatwedo/cargo/dangerous_goods/Pages/lithium_batteries.aspx



The Power adapters shall not be used without an adult or Caregiver supervision.

2.4 Mounting



The Tobii Dynavox I-Series should be mounted according to MANUFACTURER instructions of approved mounts. Tobii Dynavox or its agents are not liable for damage or injuries to a person or its property due to a Tobii Dynavox I-Series falling from a mounted configuration. The mounting of a Tobii Dynavox I-Series is done entirely at the user's own risk.

2.5 Emergency



Do not rely on the Tobii Dynavox I-Series device for emergency calls or banking transactions. We recommend having multiple ways to communicate in emergency situations. Banking transactions should only be carried out with a system recommended by, and approved according to the standards of your bank.

2.6 Electricity



Do not open the casing of the Tobii Dynavox I-Series device, since you may be exposed to potentially hazardous electrical voltage. The device contains no user serviceable parts.

2.7 Child Safety



The Tobii Dynavox I-Series are advanced computer systems and electronic devices. As such they are composed of numerous separate, assembled parts. In the hands of a child certain of these parts have the possibility of being separated from the device, possibly constituting a choking hazard or another danger to the child.

Young children should not have access to, or the use of, the device without parental or guardian supervision.

2.8 Software



Windows 10 comes with Windows Defender included, providing protection from viruses, malware, and other potential threats. Regardless of whether you use Windows Defender or a third party anti-virus software, we recommend that you always keep your antivirus software up-to-date.



Software other than that which is pre-installed on the Tobii Dynavox I-Series is installed at the user's own risk. External software could cause the Tobii Dynavox I-Series to malfunction and might not be covered by the warranty.

2.9 Magnetic Field



The Tobii Dynavox I-Series device contains magnets. Magnetic fields may interfere with pacemakers, defibrillators, or other medical devices. As a general rule, maintain a minimum distance of 6 inches (15 centimeters) between any item with magnets and your heart device.

If you suspect that the Tobii Dynavox I-Series device is interfering with your pacemaker or any other medical device, stop using the Tobii Dynavox I-Series device and consult your physician for specific information about that affected medical device.

2.10 Third Party



Any use of the Tobii Dynavox I-Series outside the intended use and together with any third party software or hardware that changes the intended use is a risk and nothing that Tobii Dynavox can take any responsibility for.

2.11 Environmental Control



The Programmable IR Remote Control — Environmental Control Unit (ECU) is not to be relied on as the only method of interaction with IR controlled devices.

3 Overview of the I-110

3.1 Key Features

The I-110 has several built-in features.

- 2 × Cameras
- 1 × Internal microphone
- 1 × USB—A (full size) 3.0 connector
- 1 × DC Power Connector
- 2 × 3.5 mm Switch ports
- 2 × Internal speaker
- 1 × Bluetooth®
- 1 × WLAN (Wireless Local Area Network)
- 4 × IR transmitters and 1 × IR receiver

3.2 Product Layout

A Tobii Dynavox I-Series device has a color Capacitive touch, LED Backlight screen. The I-110 has an 10.1" screen with a 1920 × 1200 pixel resolution.

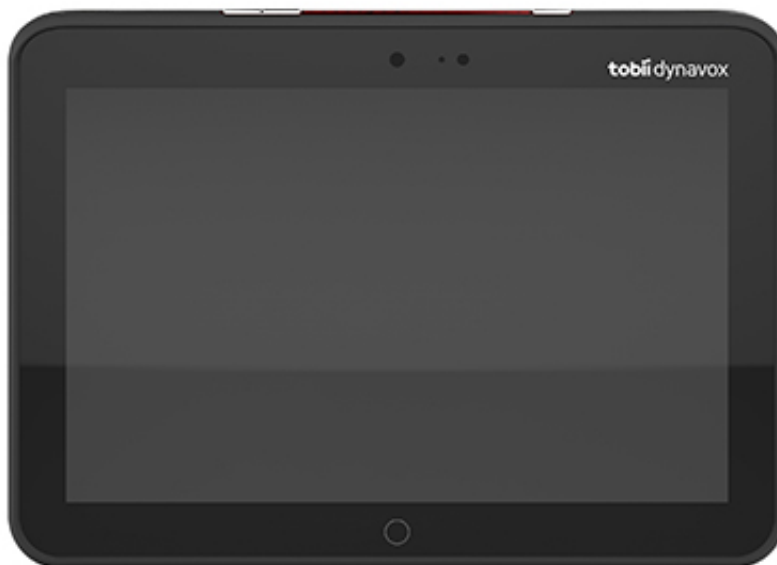

3.2.1 Ports, Sensors and Device Buttons

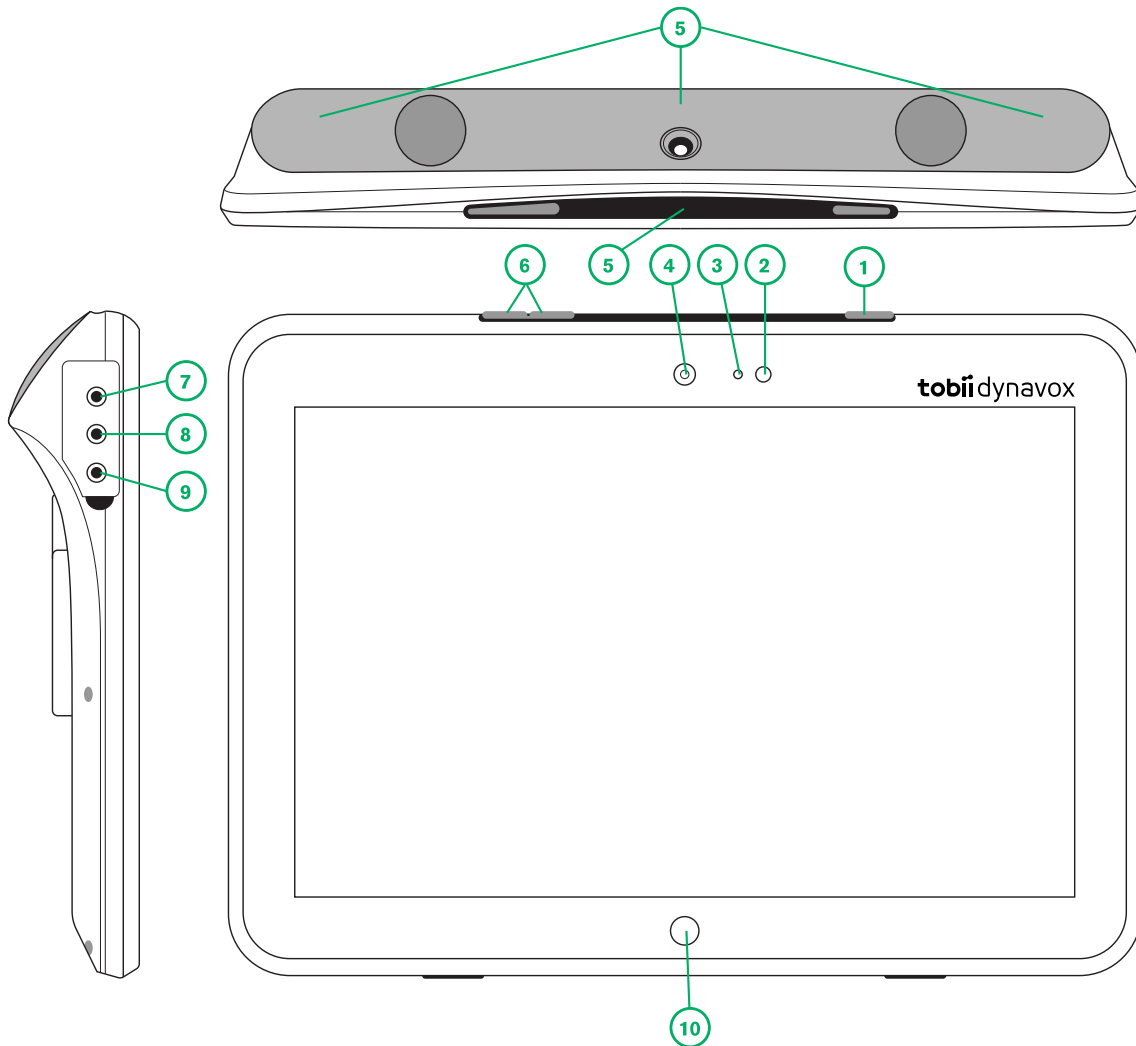

Figure 3.1 Tobii Dynavox I-Series Tablet

| Position | Description | Position | Description |
|----------|-----------------------------|----------|------------------------|
| 1 | Power Button | 6 | Volume Buttons |
| 2 | Power LED | 7 | Head phone jack 3,5 mm |
| 3 | Light Sensor | 8 | Switch port 1, 3,5 mm |
| 4 | Camera 2 MP Auto Focus (AF) | 9 | Switch port 2, 3,5 mm |
| 5 | IR Remote Control | 10 | Windows Home Button |

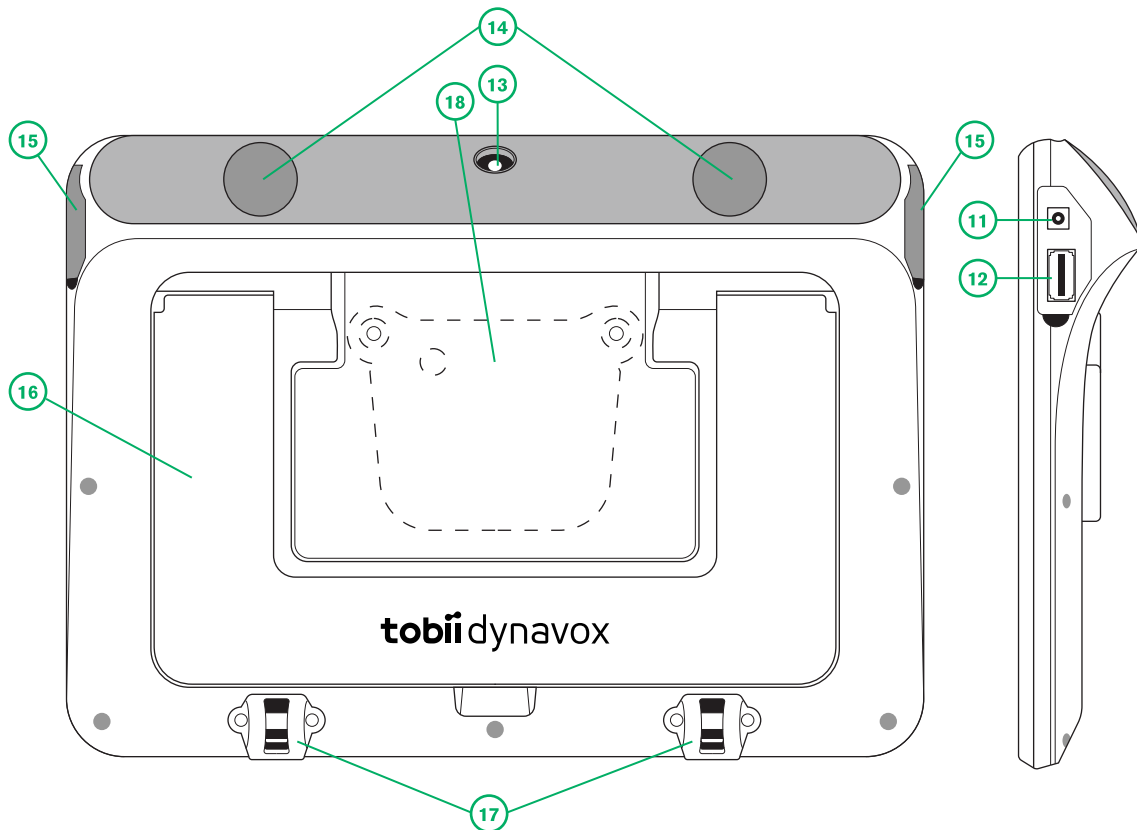

Figure 3.2 Tobii Dynavox I-Series Tablet

| Position | Description | Position | Description |
|----------|----------------------------|----------|------------------------------|
| 11 | DC Power Connector | 15 | I/O Covers |
| 12 | USB 3.0 Connector | 16 | Stand |
| 13 | Camera 8MP Auto Focus (AF) | 17 | Carrying Strap Connectors |
| 14 | Speakers | 18 | Adapter Plate (not included) |



Never force a connector into a port. If the connector and port do not join with reasonable ease, they probably do not match. Make sure that the connector matches the port and that you have positioned the connector correctly in relation to the port.

Be extra careful with the USB connectors.

3.3 Preinstalled Software

The Tobii Dynavox I-Series device is delivered with all pre-ordered and required software installed and ready to use. Should a reinstallation become necessary at any stage, perform a factory reset using Windows 10 built in factory restore options.

4 Batteries in the Tobii Dynavox I-Series

4.1 Batteries

The Tobii Dynavox I-Series device has one built-in battery and a battery indicator. The battery indicator will send out a warning of Low battery when the battery drops below 10% of its capacity. If the Tobii Dynavox I-Series device is not powered up by the power supply for charging, the Tobii Dynavox I-Series device will shut down automatically. For more information, see *Appendix D Technical Specifications, page 24*.

4.2 Charging the Tablet

1. Connect the Power cable to the Power Connector on the device.
2. Connect the Power adapter to an electrical outlet and charge the tablet until the battery is fully charged.

For device storage and battery charging temperatures, see *2 Safety, page 9*.

4.2.1 LED Behavior

The LED will shine or blink with three (3) different states:

- Green — Fully charged/In operation
- Blue
 - Solid — Charging
 - Blinking — Low battery

5 Using the Tobii Dynavox I-Series

No skill other than reading is necessary for setting up the Tobii Dynavox I-Series device. Follow this User's Manual and the Quick Start Manual.

5.1 Starting the Device

Press the power button on the top of the device. (Position 1 in *Figure 3.1 Tobii Dynavox I-Series Tablet, page 13*) to start the Tobii Dynavox I-Series.

5.1.1 First Start Up

When you start your Tobii Dynavox I-Series for the first time, you are required to go through a couple steps to set your I-Series up with the correct software and language installation. The whole process usually takes between 10-15 minutes.

Immediately after booting up the I-Series, you will be taken through the Windows Out-of-box experience (OOBE). It will require you to acknowledge both Microsoft and Tobii Dynavox End User License Agreement. This is also where you set up language and time-zone preferences. You will also be able to connect to a WIFI-network. Simply follow the instructions on screen to progress to the next step.

 Internet-connectivity is not a requirement.

Once completing the above steps, a Tobii Dynavox setup guide will launch. The setup guide will ask you for a QR-code that defines what Tobii Dynavox software is to be installed. The QR-code is supplied on paper with your device, and the setup guide will let you use the built-in rear camera to scan it. Alternatively, you can also manually enter the license code, found on the same paper as the QR-code. Once the QR-code/license number is successfully read, the system will spend approximately 5-10 minutes configuring your Tobii Dynavox Communication software. In the meantime, you will be asked to acknowledge safety information and manage device settings. Once your software is configured and ready to go, you will be automatically notified.

5.1.2 Password Information

The Tobii Dynavox I-Series device is configured to start up without a password. Though unusual, there are situations in which the password window could pop up; for example, when creating a new user in the operating system, when returning from the operating system's sleep mode or when downloading software updates from the internet.

 If you decide to use a password for your user account on your Tobii Dynavox I-Series device, be sure to write it down in a safe place for later use. Without the operating system's access password, Tobii Dynavox Support may be unable to assist you until you have recovered it through Microsoft.

The password is case sensitive.

Should the password window pop up, requiring a password, you need to know the password or where to find it. In order to type in the password use the Windows On-Screen Keyboard or an external USB keyboard (not included).

5.1.3 The Discover Tobii Dynavox app

Every Tobii Dynavox I-Series comes with the Discover Tobii Dynavox app pre-installed. Discover Tobii Dynavox is a resource for users and caregivers providing useful information and tips about your device and installed software, such as implementation guides, support information and instructional videos. The Discover Tobii Dynavox app is continuously maintained with up to date information and links.

 The Discover Tobii Dynavox will open some content in a new web browser window.

5.2 Shutting Down the Tobii Dynavox I-Series

The device should be shut down using the following:

- Use the start menu in Windows (recommended when possible).

Should you be unable to shut the device down using the above, you can hold the power button on the top side of the device down for more than ten (10) seconds. The device will consequently shut down immediately, without waiting for open applications to close.



This is not considered a "clean" Windows shut down and is thus not recommended unless completely necessary because it can harm your device.

5.3 Power Saving

The Power saving settings in the Tobii Dynavox I-Series device are preset to optimize the battery run-time. If needed, the time setting for sleep mode can be adjusted in Windows Power Options.

5.3.1 Turn Off/On the Screen

Turn Off Screen

- A single press of the power button will turn off the screen and the device will be idle.

Turn On Screen

- A single press of the power button and you should be back where you left off.
- Alternatively you can long hold the home button to wake up the device.

5.4 Using the Cameras

The two built-in cameras allow you to take snapshots of items facing the backside of the Tobii Dynavox I-Series device and also from the display side.

Use **Tobii Dynavox Communication Software** or other relevant software to operate the cameras.

5.5 Adjusting the Volume

To adjust the volume use the Volume Up and Down buttons (Position 2) on top side of the Tobii Dynavox I-Series device. For position references, see *Figure 3.1 Tobii Dynavox I-Series Tablet, page 13*



Volume adjustments can also be done in **Tobii Dynavox Communication Software** and in Windows.

5.6 Adjusting the Sound

You can configure the speakers using the **Windows 10 Control Panel > Sound**.



We refer to Microsoft's information on how to configure the sound in the Windows 10 Control Panel.



Sound adjustments can also be done in **Tobii Dynavox Communication Software**.

6 Product Care

6.1 Temperature & Humidity

6.1.1 General Use - Operating Temperature

The Tobii Dynavox I-Series is best kept in dry conditions at room temperature. The recommended range for temperature and the humidity value for the device is as follows:

- Ambient temperature: 0°C to 37°C (32°F to 99°F)

6.1.2 Transportation and Storage

For transportation and storage excluding batteries the recommended range for temperature and the humidity value for the device is as follows:

- Temperature: -40°C to 65°C (-40°F to 149°F)

The Tobii Dynavox I-Series has a water-resistancy rating of IP54, but still isn't waterproof. The device should not be kept in excessively humid, damp, or otherwise wet conditions. Do not submerge the device in water or in any other liquid. Be careful not to allow liquids to be spilled upon the device, especially in the connector areas.

6.2 Cleaning

Before cleaning the Tobii Dynavox I-Series device, shut it down and unplug all cables. Use a soft, slightly damp lint-free cloth. Avoid getting moisture in openings on the device. Don't use window cleaners, household cleaners, aerosol sprays, solvents, alcohol, ammonia, or abrasives to clean the device.

6.2.1 Cleaning of the Speakers

If the openings for the speakers are clogged, carefully use cotton sticks and/or a toothbrush to avoid damaging the Tobii Dynavox I-Series speakers.

6.3 Placement

Only use the recommended mounts specified by your local reseller or sales representative and make sure that they are mounted and fastened correctly according to the instructions. Do not place the device on unstable and uneven surfaces.

6.4 Transporting the Tobii Dynavox I-Series Device

Disconnect all the cables from the Tobii Dynavox I-Series while carrying the device.

When you transport the device for repair, shipment, or traveling, use the original casing and packaging materials.



It is recommended to keep the original packaging materials for the Tobii Dynavox I-Series.

If device needs to be returned to Tobii Dynavox for Warranty related issues or repair, it is beneficial that the original packaging or equal equivalent is used for shipping. Most shipping carriers require at least 2 inches of packing material around the device.

Please note: Due to Joint Commission regulations, any shipping materials including boxes sent to Tobii Dynavox must be discarded.

6.5 Disposing of the Tobii Dynavox I-Series Device

Do not dispose of the Tobii Dynavox I-Series Device in general household or office waste. Follow your local regulations for the disposal of electrical and electronic equipment.

Appendix A Support, Warranty, Training Resources

A1 Customer Support

For support, please contact your local representative or Support at Tobii Dynavox. In order to receive assistance as quickly as possible, make sure you have access to your Tobii Dynavox I-Series device and, if possible, an Internet connection. You should also be able to supply the serial number of the device, which you will find on the Service tag label.

For further product information and other support resources, please visit www.tobiidynavox.com or www.myTobiiDynavox.com.

A2 Warranty

Please read the Manufacturer's Warranty paper included in the package.

Please read this User's Manual carefully before using the device. The warranty is only valid if the device is used according to the User's Manual. Disassembling the Tobii Dynavox I-Series device will void the warranty.



It is recommended to keep the original packaging materials for the Tobii Dynavox I-Series.

If device needs to be returned to Tobii Dynavox for Warranty related issues or repair, it is beneficial that the original packaging or equal equivalent is used for shipping. Most shipping carriers require at least 2 inches of packing material around the device.

Please note: Due to Joint Commission regulations, any shipping materials including boxes sent to Tobii Dynavox must be discarded.

A3 Training Resources

Tobii Dynavox offers a range of training resources for the Tobii Dynavox I-Series and related communication products. The easiest way to find them, is through the Discover Tobii Dynavox application installed on the device, or by visiting www.tobiidynavox.com or www.myTobiiDynavox.com. This includes Getting Started Guides, webinars, and Quick Start Guides. The Tobii Dynavox I-Series Quick Start Guide is delivered with, and stored on, the Tobii Dynavox I-Series device.

Appendix B Compliance Information

B1 FCC Statement

This device complies with Part 15 of the FCC Rules. Operation is subject to the following two conditions: (1) this device may not cause harmful interference and (2) this device must accept any interference received, including interference that may cause undesired operation.



Modifications not expressly approved by Tobii Dynavox could void the user's authority to operate the equipment under FCC rules.

B1.1 For P15B Equipment

This equipment has been tested and found to comply with the limits for a Class B digital device, pursuant to part 15 of the FCC rules. These limits are designed to provide reasonable protection against harmful interference in a residential installation. This equipment generates, uses and can radiate radio frequency energy and, if not installed and used in accordance with the instructions, may cause harmful interference to radio communications.

However, there is no guarantee that interference will not occur in a particular installation. If this equipment does cause harmful interference to radio or television reception, which can be determined by turning the equipment off and on, the user is encouraged to try to correct the interference by one or more of the following measures:

- Reorient or relocate the receiving antenna.
- Increase the separation between the equipment and receiver.
- Connect the equipment into an outlet on a circuit different from that to which the receiver is connected.
- Consult the dealer or an experienced radio/TV technician for help.

B1.2 For Portable Devices

FCC RF Radiation Exposure Statement:

1. This Transmitter must not be co-located or operating in conjunction with any other antenna or transmitter.
2. This equipment complies with FCC RF radiation exposure limits set forth for an uncontrolled environment. This device was tested for typical hand held operations with the device contacted directly to the human body to the sides of the device. To maintain compliance with FCC RF exposure compliance requirements, avoid direct contact to the transmitting antenna during transmitting.

B2 Radio Wave Exposure and Specific Absorption Rate (SAR) Information

The Tobii Dynavox I-Series device has been tested as a Class 1 Medical Device. Medical electrical equipment such as this requires special caution regarding Electro-magnetic Compatibility (EMC) and thus needs to be installed and placed into service according to the information provided in this manual.



Using other cables and accessories other than those provided or that are integrated in the device may affect EMC performance.

The SAR (Specific Absorption Rate) limit as dictated by the FCC (in the USA) and by the IC (in Canada) is 1.6W/kg averaged over 1 gram of tissue. In Europe/EU (CE regulations) it is 2.0 W/kg averaged over 10 grams of tissue. The Devices, I-110 (FCC ID: W5M-TDI110), (IC ID 5534A-TDI110) have been tested against these SAR limits to maintain compliance with FCC/IC/CE RF exposure requirements.

This equipment complies with FCC/IC/EU RF radiation exposure limits set forth for an uncontrolled environment.

The highest SAR value for the I-110 device is 0.3 W/kg.

In order to maintain compliance as a Class 1 Medical device, the switches that are used in combination with the Tobii Dynavox I-Series device must fulfill the isolation requirements of IEC/EN 60601-1 based on 15 V DC. They must be electrically floating switches (switches that are not grounded).

B3 Industry Canada Statement

Caution:

- (i) the device for operation in the band 5150-5250 MHz is only for indoor use to reduce the potential for harmful interference to co-channel mobile satellite systems;
- (ii) the maximum antenna gain permitted for devices in the bands 5250-5350 MHz and 5470-5725 MHz shall be such that the equipment still complies with the e.i.r.p. limit;
- (iii) the maximum antenna gain permitted for devices in the band 5725-5850 MHz shall be such that the equipment still complies with the e.i.r.p. limits specified for point-to-point and non-point to-point operation as appropriate; and
- (iv) Users should also be advised that high-power radars are allocated as primary users (i.e. priority users) of the bands 5250-5350 MHz and 5650-5850 MHz and that these radars could cause interference and/or damage to LE-LAN devices.

Avertissement:

- (i) les dispositifs fonctionnant dans la bande 5150-5250 MHz sont réservés uniquement pour une utilisation à l'intérieur afin de réduire les risques de brouillage préjudiciable aux systèmes de satellites mobiles utilisant les mêmes canaux;
- (ii) le gain maximal d'antenne permis pour les dispositifs utilisant les bandes de 5250 à 5350 MHz et de 5470 à 5725 MHz doit être conforme à la limite de la p.i.r.e.;
- (iii) le gain maximal d'antenne permis (pour les dispositifs utilisant la bande de 5725 à 5850 MHz) doit être conforme à la limite de la p.i.r.e. spécifiée pour l'exploitation point à point et l'exploitation non point à point, selon le cas;
- (iv) De plus, les utilisateurs devraient aussi être avisés que les utilisateurs de radars de haute puissance sont désignés utilisateurs principaux (c.-à-d., qu'ils ont la priorité) pour les bandes 5250-5350 MHz et 5650-5850 MHz et que ces radars pourraient causer du brouillage et/ou des dommages aux dispositifs LAN-EL.

ICES-003 caution:

This Class [B] digital apparatus complies with Canadian ICES-003.

Cet appareil numérique de la classe [B] est conforme à la norme NMB-003 du Canada.

This device (IC ID: 5534A-TDI110) has been tested to the safety requirements for exposure to radio waves (SAR) in RSS-102 to the General Public (Uncontrolled Environment) limits (1.6W/Kg). The highest SAR value for the I-110 device is 0.3 W/kg. This device can be operated safely with a minimum distance 0 cm between the equipment and the user's body.

Ce dispositif (IC ID: 5534A-TDI110) a été testé aux exigences de sécurité pour l'exposition aux ondes radio (SAR) dans le CNR-102 à le grand public (environnement non contrôlé) des limites (1.6W/Kg). La valeur maximale mesurée de SAR pour le I-110 dispositif est: xx.xx W/kg. Ce dispositif peut être exploité en toute sécurité avec un 0cm distance minimale entre le matériel et les corps de l'utilisateur.

This device complies with Industry Canada licence-exempt RSS standard(s).

Operation is subject to the following two conditions: (1) This device may not cause interference, and (2) This device must accept any interference, including interference that may cause undesired operation of the device.

Le présent appareil est conforme aux CNR d'Industrie Canada applicables aux appareils radio exempts de licence.

L'exploitation est autorisée aux deux conditions suivantes:

- (1) l'appareil ne doit pas produire de brouillage, et
- (2) l'utilisateur de l'appareil doit accepter tout brouillage radioélectrique subi, même si le brouillage est susceptible d'en compromettre le fonctionnement.

B4 CE Statement

This equipment complies with the requirements relating to electromagnetic compatibility, the essential protection requirement of Electromagnetic Compatibility (EMC) Directive 2014/30/EU on the approximation of the laws of the Member States relating to electromagnetic compatibility and Radio Equipment Directive (RED) 2014/53/EU to meet the regulation of the radio equipment and telecommunications terminal equipment.

B5 Standards

We, Tobii AB, hereby declare that the Tobii Dynavox I-Series listed in this manual complies with the following directives:

- Medical Device Regulation (MDR)
- Low voltage Directive 2014/35/EU
- Electromagnetic Compatibility (EMC) Directive 2014/30/EU
- Radio Equipment Directive (RED) 2014/53/EU
- RoHS2 Directive 2011/65/EU
- WEEE Directive 2012/19/EU
- Reach Directive 2006/121/EC, 1907/2006/EC Annex 17
- Batteries Directive 2013/56/EU

The following standards have been used:

- CAN/CSA-C22.2 NO. 60601-1:14
- ANSI/AAMI ES60601-1:2005/A1:2012 & C1:2009/ (R)2012 & A2:2010/(R)2012

- EN 60601-1:2006+A1:2013
- EN 62366-1:2015+EN60601-1-6
- EN 60601-1-11 : 2015
- IEC 60068-2-64: 2008
- EN 60068-2-27:2009
- EN 60529:1991+A2:2013
- ISO 14971 : 2007
- EN 62366:2007+A1:2014
- EN 60601-1-6:2004(edition 1)
- IEC 60950-1:2005+AMD1:2009+AMD2:2013
- AS/NZS CISPR 22:2009
- AS/NZS 60950.1:2003
- CFR 47 Part 15B
- CFR 47 Part 15C (2.4GHz) BT
- CFR 47 Part 15C (2.4GHz) 802.11 b/g/n
- CFR 47 Part 15E (5 GHz, Band1, 2, 3, 4)
- CFR 47 DFS (Slave, Dynamic Frequency Selection)
- CFR 47 FCC - Medical - Part 18
- EN 55032(EMI) / EN55024(EMS)
- EN 55011
- EN 60601-1-2
- EN 301489-1/EN301489-17 (2.4GHz/5GHz WiFi&BT)
- EN 300328
- EN 301893
- CE DFS (Slave, Dynamic Frequency Selection)
- EN50566/EN62209((FCC&CE integrated package price))
- AS/NZSCISPR22
- AS/NZS4268 (2.4GHz, WiFi+BT)
- AS/NZS4268 (5GHz, Band1-3)
- ICES-003 (Issue 6)
- RSS-247 (Issue 2, BT) [Typo RSS-2010 in SRS B12, revised by RSS-247]
- RSS-247 (Issue 2, 2.4G & 5GHz WiFi) [Typo RSS-2010 in SRS B12, revised by RSS-247]
- RSS-GEN (Issue 4)
- RSS-102 (Issue 4) 5GHz
- ICES-001
- RSS-247, LPD (For 1-6GHz_Review Fee) one ICID only

B6 IECCE CB Scheme

For Tobii Dynavox I-Series, CB Scheme is pending for additional markets (Australia, New Zealand, Argentina, Mexico, South Africa, China...).

Appendix C Maximum Allowed Temperature

Table C.1 Maximum Allowed Hotspot Temperature

| Allowable maximum temperature for skin contact of the Tobii Dynavox I-Series metal surfaces. | Maximum Temperature °C/°F |
|--|---|
| | Hotspot ⁱ surface under stand. Not likely to be touched |
| Surface may feel warm if continued skin contact. | 47/117 (55/131 is limit for ITE ⁱⁱ) |
| Surface temperature may start to feel uncomfortable if continued skin contact. | 55/131 (70/158 is limit for ITE ⁱⁱ) |
| Temperature DEVICE SHUT OFF — not to cause risk of harm. | 60/140 (device max limit) |
| i. For Hotspot location, see <i>Figure C.1 Hotspot Temperature Area, page 23.</i> ii. ITE refers to Information Technology Equipment, i.g. computers, tablets devices etc | |

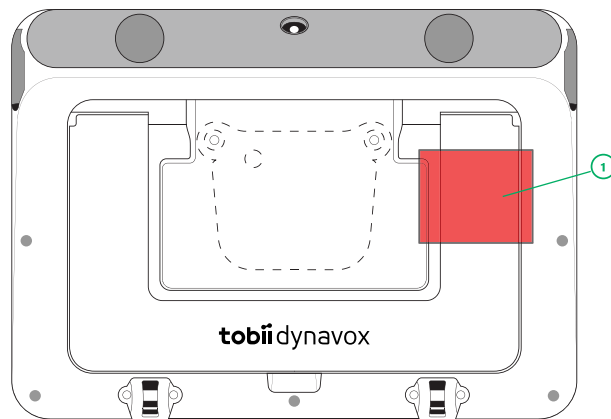

Figure C.1 Hotspot Temperature Area

The Tobii Dynavox I-Series device may get warm and to avoid discomfort there are three (3) temperature levels the device will be monitoring by itself. If the temperature reaches the first level in *Table C.1 Maximum Allowed Hotspot Temperature* a notification will be shown on the screen to inform the user. This is to avoid any risk of discomfort for the user due to the device being warm.

The second level notification will inform of the risk that the I-Series will shut down if it will become warmer. This temp level may also cause the user discomfort if holding the device for a longer time.

If reaching the third level, the I-Series device will shut down not to risk the temperature to cause any risk of harm to the user.

If the user tries to start the I-Series when the device temperature is above the third level, the device will automatically shut down during start up. Let the I-Series cool down and try starting the device when the device temperature is below the third level.

Appendix D Technical Specifications

D1 Tobii Dynavox I-Series Device

| Standard | Tobii Dynavox I-Series |
|---|--|
| Type/Model | I-110 |
| Screen | 10.1", Aspect ratio: 16:10, LED Backlight Unit |
| Screen Resolution | 1920 × 1200 |
| Touch Panel | Multi point Capacitive Touch NEG T2X-1glass |
| Dimensions (WxHxD) | 258 × 186 × 38 mm 10.2 × 7.3 × 1.5 inches |
| Weight | 1.15 kg 2.54 lbs |
| Speakers | 2 × 31 mm 4 ohm, 4 W |
| Microphone | 2× Analog Microphone |
| Processor | Intel Atom Z8350 – 4 cores, 2 MB cache, 1.92 Ghz |
| RAM | 4 GB |
| Operating system | Microsoft® Windows 10 Pro 64-Bit |
| Flash drive | 128 GB eMMC |
| Sensors | 3-axis gyro, accelerometer, compass, ambient light sensor |
| Connectors | 1 × 3.5 mm Headset/Audio-out port (stereo) with jack detection (Headphone and microphone port) 2 × Switch port, 3,5 mm 1 × USB 3.0 |
| Buttons | 1 × Power On 1 × Volume Up 1 × Volume Down |
| WLAN/Bluetooth® | IEEE 802.11 a/b/g/n Bluetooth® 4.0 / BLE |
| IR Remote Control (Environmental Control Unit) | Learning remote with integrated library of pre-programmed devices |
| Camera | Rear-facing: 8 Mega pixels Front-facing: 2 Mega pixels |
| IP class | IP 54 (with I/O covers in place) |
| Battery Run Time | > 8 hours. normal usage |
| Battery Technology | Li-ion Polymer rechargeable battery |
| Battery Capacity | ~30 Wh |
| Battery Charge Time | < 4 hours |

D2 Power Adapter

| Item | Specification |
|---------------------|------------------------------|
| Trademark | ADAPTER TECH. |
| Manufacturer | Adapter Technology Co., Ltd. |
| Model Name | ATM036T-A150 |
| Rated Input | 100–240V~50-60Hz, 1A–0.45A |
| Rated Output | 15VDC, 2.4A |
| Output Plug | Barrel connector |

Appendix E Approved Accessories

| Description | Model | Tobii Dynavox Part No. |
|--|--------------------------|------------------------|
| Tobii Dynavox I-Series AC Adapter (Power Supply) | AdapterTech ATM036T-A150 | |

For information about the latest approved Accessories for the Tobii Dynavox I-Series, please visit www.TobiiDynavox.com or contact your local Tobii Dynavox reseller.



Copyright ©Tobii AB (publ). Illustrations and specifications do not necessarily apply to products and services offered in each local market. Technical specifications are subject to change without prior notice. All other trademarks are the property of their respective owners.

Support for Your Tobii Dynavox Device

Get Help Online

See the product-specific Support page for your Tobii Dynavox device. It contains up-to-date information about issues and tips & tricks related to the product. Find our Support pages online at: www.TobiiDynavox.com or www.myTobiiDynavox.com.

Contact Your Sales Representative or Reseller

For questions or problems with your product, contact your Tobii Dynavox sales representative or authorized reseller for assistance. They are most familiar with your personal setup and can best help you with tips and product training. For contact details, visit www.TobiiDynavox.com/contact