

INSTRUCTION MANUAL

HF LINEAR POWER AMPLIFIER

MODEL : HL-2.5KFX



 **TOKYO HY-POWER**

1. Introduction

Thank you for purchasing the HL-2.5KFX. This compact and lightweight desktop HF linear power amplifier has a maximum input power of 2.9 kW. Our solid-state broadband power amp technology makes it the smallest and lightest in the industry.

Typical output power is 1.5 kW PEP/SSB with the drive power of 85-90 W. The built-in band decoder will let you forget about the band setting when the amplifier is connected to your modern radio through such band data cables as ICOM CI-V, DC voltage (ICOM, Yaesu), and RS-232C (Kenwood). All the data cables are included in your amplifier for your convenience.

2. Cautions

2-1 Unpack the amplifier, check the fan guard at the rear panel Fan to see if there is any damage caused by the physical shock during the transportation. Fan blades must be free to rotate when powered.

The amplifier is cooled by forced airflow. Several inches of clearance on the top and the rear wall are necessary to allow for smooth air intake into the fan. Do not block the air vents on the top cover.

2-2 Keep the amplifier out of direct sunlight, in a cool dry environment.

2-3 Internal high voltages, (AC, DC and RF), are present at all times, ON AIR or OFF. Internal access should be limited to avoid injury.

2-4 Turn off the AC main power immediately upon any unusual sounds, sights or odors. Check the multimeter readings of V_d and I_d , the fuses and all cable connections around the amplifier. Please notify the dealer or the factory of any problems.

2-5 For your safety, do not operate the amplifier without adequate grounding. A proper ground connection will result in peak performance and stability, in addition to reduced RF strays or noises.

2-6 To eliminate the RF interference to such home appliances as TV, FM radio, telephone sets, etc., it is recommended that clamp-on ferrite cores be

inserted at both ends of the remote control cable, ALC cable, coaxial jumper cable, and antenna cables, as needed. Also, a common mode AC line filter (near the AC outlet), and in-line low pass filters on the antenna coaxial cable, (as necessary), are recommended.

2-7 The amplifier has fast acting sophisticated protection circuits controlled by the latest microprocessor technology. Please note, however, any such actions that cause the same fault to occur repeatedly, will lead to failure of the valuable final power FET transistors. Also note that the full power CW (or carrier) drive under the erroneous MANUAL BAND SET leads to the failure of the final power FET's (See page 11, Section 7. *Connection*). In this sense, it is highly recommended that the amplifier is connected to the radio with supplied Band Data Cable.

2-8 Before checking inside the amplifier, be sure to wait a few minutes for the high DC voltage to discharge (monitor Vd meter reading). The internal potentiometers for RF power detector, protection circuits, FET bias voltage circuit, etc., are precisely adjusted at the factory, and should not be altered. Doing so, would require readjustment with precision measuring instruments.

2-9 The primary power transformer is factory pre-wired for AC 240 V operation. (See page6, Section 5. *AC Line Voltage*) Be sure to verify your AC line voltage before you plug the AC power cord into the outlet.

2-10 Before powering on the amplifier, be sure to connect a dummy load (50 ohms, 1.5 kW min.) or a well-adjusted antenna to the output terminal. Operating without any load will cause extreme stress to the RF power FET's, although protection circuits should work under critical conditions.

2-11 Required drive power is slightly less than 100 W to obtain the full 1.5 kW output. Do not attempt to operate with excessive drive from a high power transceiver. Transmitting high drive RF (over 100 W) into the amplifier will void the warranty.

2-12 Keep the aluminum heat sink and air openings free from dust and blockages. Periodic cleaning will prevent degraded cooling efficiency.

2-13 For long continuous operation in RTTY/FM modes, it is recommended you reduce the RF drive levels by 20% to 30% lower output than CW/SSB modes.

2-14 To prevent damage to the precision electronic components, avoid extreme physical shock to the amplifier. If factory service is required, the amplifier **MUST** be shipped using the original box and packaging materials.

3. Features

3-1 Our solid-state broadband design engineers worked to make the HL-2.5KFX, the lightest and most compact 1.5 kW HF amplifier in the industry. This world-class compact 1.5 kW HF amplifier is the easiest to handle and operate.

3-2 The amplifier is equipped with a newly developed band decoder. The amplifier's decoder changes bands automatically as the data signal is received from the associated HF transceiver's frequency bands.

3-3 The amplifier's main PA section includes 2 high power MOS FET ARF1500's by Microsemi, resulting in 1.5 kW PEP (SSB max.). The amplifier's broadband characteristics require no further tuning once the operating band is selected.

3-4 The amplifier allows operation in full break-in CW mode due to the use of the amplifier's high-speed antenna relays (made by Panasonic/Matsushita).

3-5 With the unique duct structure design and the powerful blower fan, the aluminum heat sink block for RF PA module (and other components), are effectively cooled. The fan's quiet operation allows for even the weakest DX signals to be heard.

3-6 The amp utilizes an advanced 16 bit MPU (microprocessor) to run the various high speed protection circuits such as overdrive, high antenna SWR, DC overvoltage, band miss-set etc.

3-7 This amplifier is compatible with AC 220 V and 240 V (200/230/250 V included). See the illustration in the AC Power Section for changing primary wiring of the power transformer.

3-8 For the safety of the operator, an Interlock system is employed. The AC power is shut down if the top cover is removed, and the automated safety interlock is activated.

3-9 An analog multimeter allows the operator to monitor Pr (Reflected power), Vd (Drain voltage of power FET), Id (Drain current) and ALC voltage.

3-10 For future expansion, the amplifier rear panel is equipped with a control cable connection socket, this is for the upcoming model HC-1.5KAT, auto antenna tuner by Tokyo Hy-Power Labs. in 2007.

4. Specifications

Frequency	:	1.8 ~ 28 MHz all amateur bands including WARC bands
Mode	:	SSB, CW, RTTY
RF Drive	:	85W typ. (100W max.)
Output Power	:	1.5 kW PEP/CW (typ.) (1.2 kW on 28 MHz band)
Matching Transceivers for Auto Band Decoder	:	Most ICOM, Yaesu, Kenwood
Drain Voltage	:	120 V (when no RF drive)
Drain Current	:	25 A max.
Input Impedance	:	50 (unbalanced)
Output Impedance	:	50 (unbalanced)
Final Transistor	:	ARF1500 x 2 (MOS FET by Microsemi)
Circuit	:	Class AB push-pull
Cooling Method	:	Forced Air Cooling
MPU	:	PIC 18F452-I/P
Multi-Meter	:	Output Power Pf 2.5 kW Reflected Power Pr 250W Drain Voltage Vd 150V Drain Current Id 40A
Input/Output Connectors	:	UHF SO-239 with low loss Teflon insulator
AC Power	:	AC 240 V (200/220/230/250 V) 15A max.
AC Consumption	:	3 kVA max. when TX
Dimension	:	325 x 145 x 405 mm (W x H x D) 12.3 x 5.7 x 15.9 inches
Weight	:	Approx. 25.2 kgs. or 57.3 lbs.
Accessories	:	AC Power Cord x 1 RCA Plug x 2 Band Decoder Cable x 3 Spare Fuse 12 A (for AC 230V line) x 2 Spare Fuse 1A (Miniature Fuse) x 3 User Manual x 1
Optional Items	:	Auto Antenna Tuner (HC-1.5KAT) High Power Cooling Fan (HXT-2.5KF for high duty cycle operation)

5. AC Line Voltage

5-1 The amplifier is designed to work with AC 240 V (200- 250 V).

5-2 The correct AC plug (not included in the package), must be obtained locally due to the AC plug variations worldwide.

5-3 The AC voltage has been factory preset for 240 V use (or as requested by the customer at the time of order). See the other illustration for AC voltages other than 240 V. For your safety, before making these adjustments, be sure to pull the AC plug from the AC outlet to avoid injury.

Guide for Tap Selection

AC Line	Tap 1	Tap 2
200V (195V-205V)	0 V	200 V
210V (205V-215V)	10 V	220 V
220V (215V-225V)	0 V	220 V
230V (225V-235V)	10 V	240 V
240V (235V-245V)	0 V	240 V
250V (245V-255V)	0 V	250 V

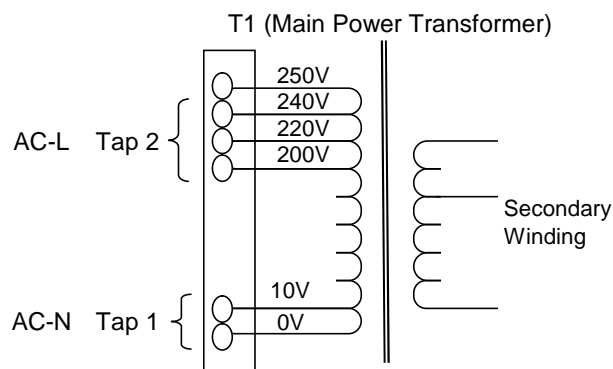

Terminal Board Connection

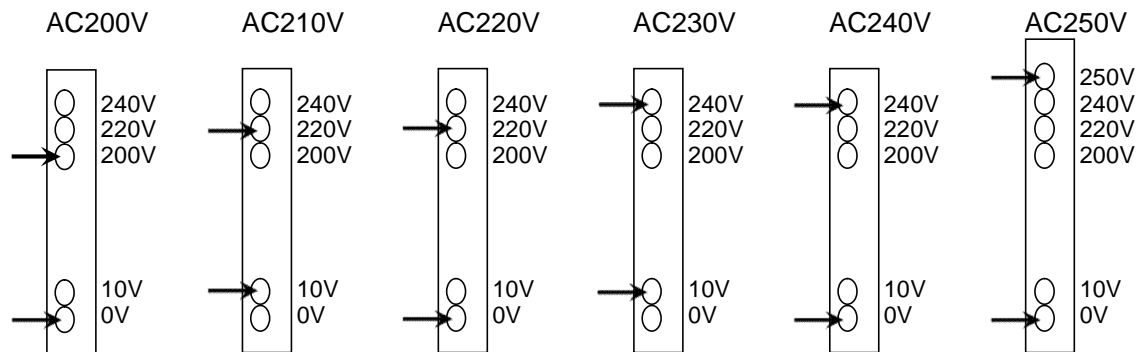

6-A Front Panel Description



- POWER** Main power switch to turn AC power on and off.
LED (green) lights when turned on.
- OPER.** OPERATE/STAND-BY switch. At OPERATE, the amplifier is ready to go into ON AIR (TX) mode and at STBY, it is on STAND-BY mode.
- METER** To change the multimeter scales. Meter reads Pr, Vd, and Id, and ALC.
- BAND-AUTO/MAN'L**
To select band switching methods AUTO or MANUAL. When using AUTO, the manufacturer for the transceiver in use should be selected. When the band data cable is not used, MANUAL should be selected. (See page 9, TRXSEL and CONT for Band Data cable Connection)
- BAND-MAN'L** Rotary switch for band change in manual mode. While the transceiver is on Receive (RX) mode, turn to select the desired frequency band to operate. The switches will not work when the transceiver and the amplifier are in Transmit (TX) mode.
- METER(PF)** Meter to read forward output power, PF. Full scale is 2.5 kW, and it reads average power.

MULTIMETER PR(Reflected power from antenna), VD (FET drain voltage), and ID(FET drain current) and ALC voltage are shown on the scale as selected by METER select switch.

Full scales are; PR:250 W, VD: 150 V, ID: 40 A, ALC: -10V.

ON AIR, FAN, ID, PROT(LED)

ON AIR : Lights when the amplifier is in transmit(TX) mode.

FAN : Lights when cooling fan is running at high speed.

When the heat sink temperature reaches 40 , cooling fan speed will continuously increase to enhance cooling capacity.

It runs at full speed when 65 is reached.

ID : Excessive ID Indicator (25 A). Depending on the band and antenna situation, high drain current may flow into FET's. If 25 A is exceeded, this LED flickers and/or lights to indicate that high ID is being drawn (This light does not necessarily mean a failure of the amplifier. However, if it lights too often, or too long, it is possible the driver power should be reduced and the antenna should be checked for SWR, to avoid stress to the FET's.).

PROT : Lights when protection circuit shuts down the amplifier. Various protection circuits are built in such as Over-drive, Band mis-set, high Ant-SWR, Over-temperature etc. Detailed explanations will follow.

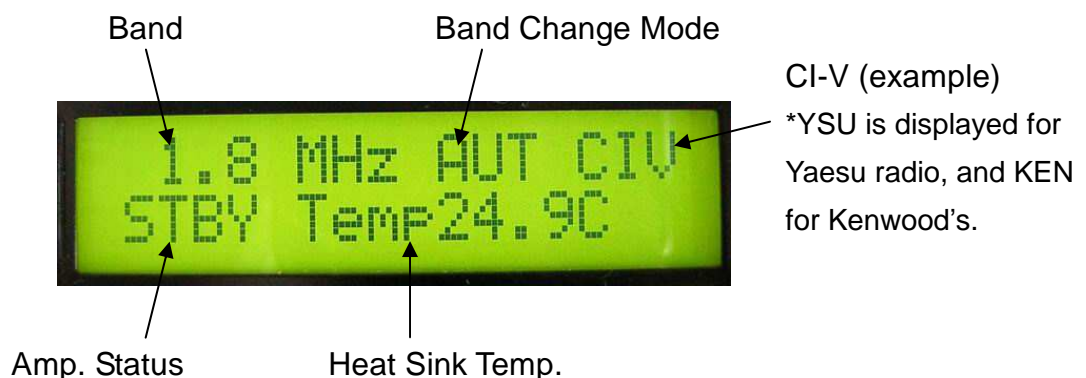

LCD Panel Displays modes of operation and protection circuit.

6-B Rear Panel Description

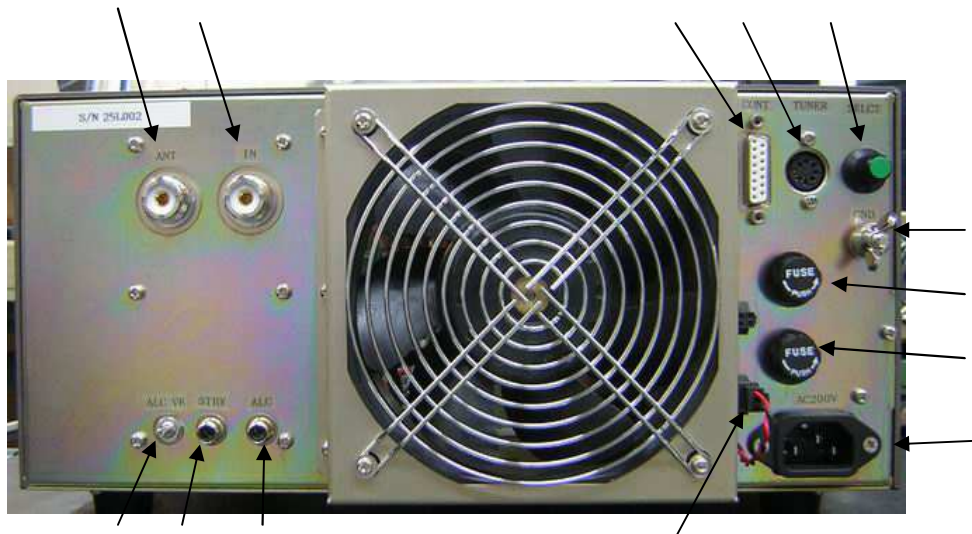

- ANT A** RF Output Connector. Connect the coax cable to the antenna.
- INPUT** RF Input Connector. Connect the coax jumper cable from the transceiver.
- CONT** D-Sub (15pin) Socket. Connect the band data cable to the transceiver.
- TUNER** DIN Socket. Connect the control cable from External Auto Antenna Tuner, HC-1.5KAT.
- TRXSEL** Switch to select the transceiver manufacturer (i.e. ICOM, Yaesu, Kenwood).
- GND** Ground Terminal.
- FUSE** A pair of fuses for AC Mains. 250 V/12 A glass fuse. (Self extinguish type.)
- AC POWER** 230 V AC Mains Socket. Socket for the AC power cord. (Socket is EMI filtered.)
- ALC ADJ.** Potentiometer to adjust ALC voltage level. Minus 10 V is available at maximum, when turned full counter-clockwise. Factory setting is 0 volts, with the pot turned full clockwise. (See page 16, Section 9. *ALC Connection* for more details.)
- SEND** RCA Jack. Connect the control cable from the ACC terminal (or

SEND, TX GND etc.) of the transceiver. Electrical conditions are 12 V DC of open voltage at receive mode (RX), and short current of 35 mA at transmit mode (TX).

ALC RCA Jack for ALC Voltage Output. Negative DC voltage appears at the center pin, which is fed back to the ALC terminal of the transceiver. ALC is used to keep the amplifier output power at certain limits. Also it is useful when the transceiver output power is higher than 100 W (See page 16, Section 9. *ALC Connection*). Also consult your HF transceiver user manual.

FAN POWER Socket to connect DC cord plug of the cooling fan.

6-C Top View

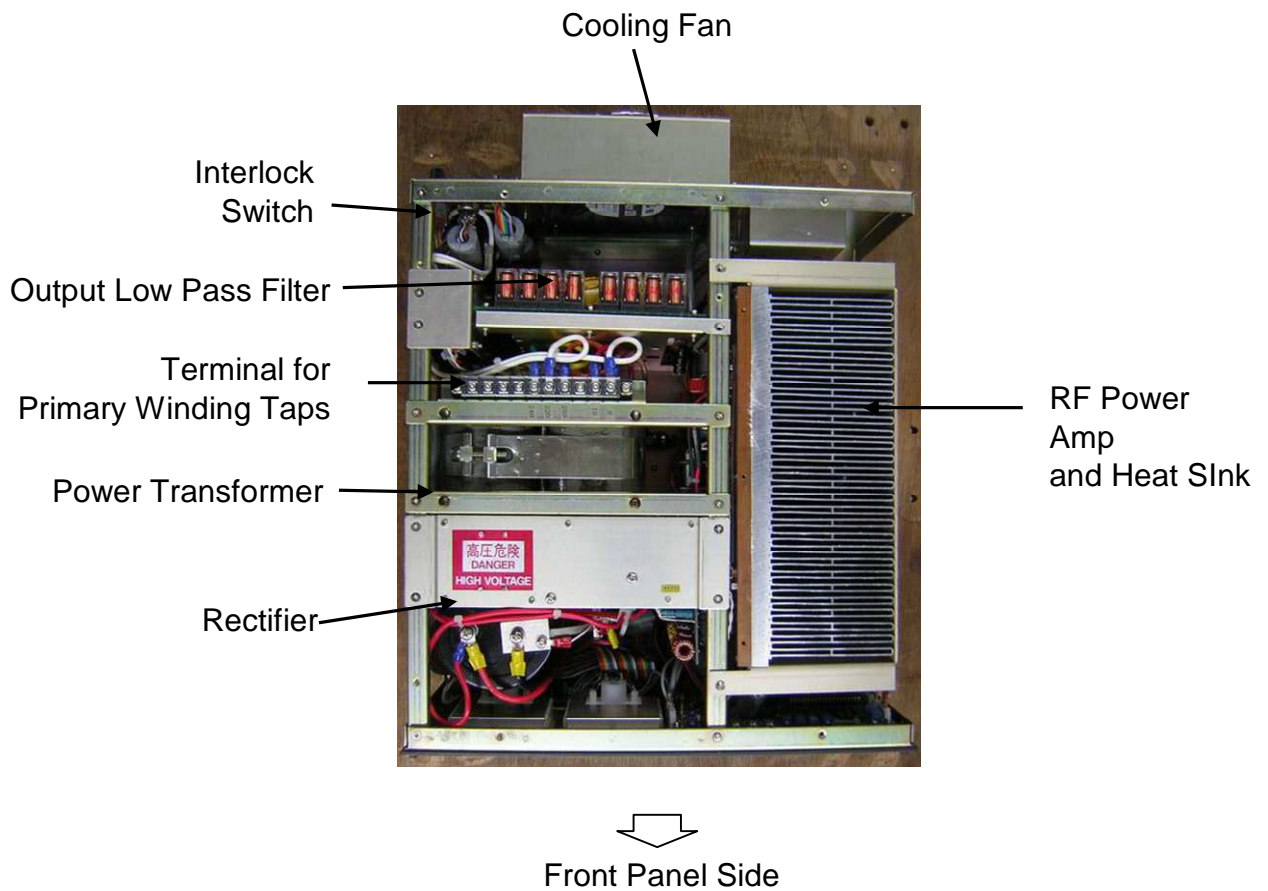

7. Connection

7-1 Connection to Transceiver and Tuner

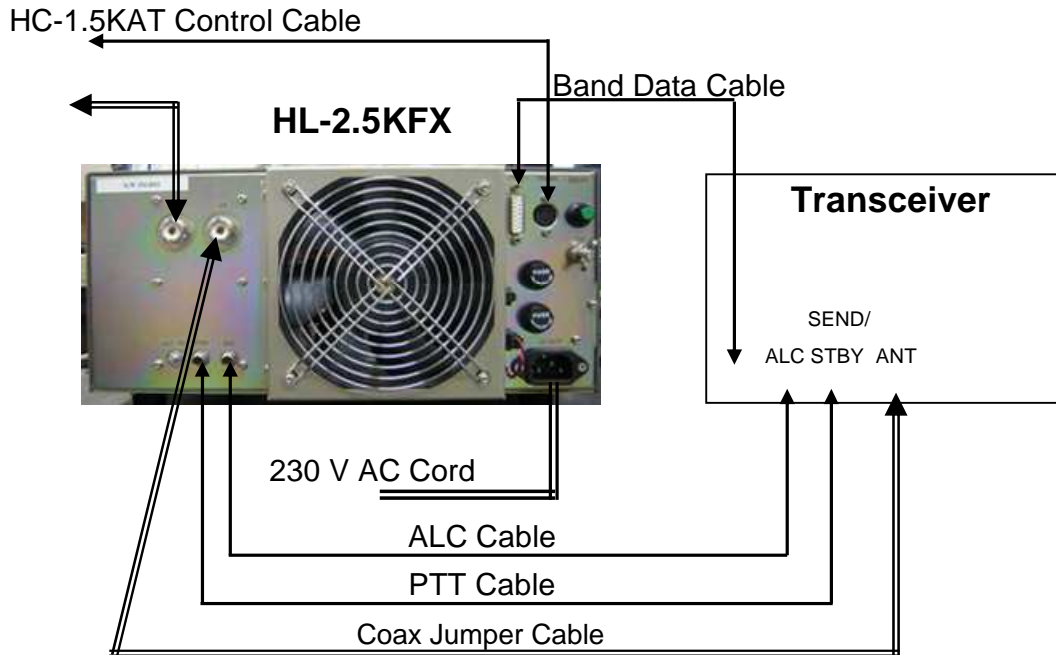

Connector and Cable List

HL-2.5KFX side		Signal	To:	Description
Display/ connector name	Cable side Connector			
AC200V IEC3P Inlet	IEC3P	AC200L	AC230V consent	AC Power Cord 200V 20A
		GND		
		AC200N		
ALC RCA-J	RCA-P	ALC Output	Transceiver ALC socket	RF output (-) rectification -10V max.
SEND RCA-J	RCA-P	PTT Input	Transceiver PTT relay	Short at TX Open at RX 12V 40mA
TUNER DIN7J	DIN7P	Tuning Control	Auto Tuner	Band tracking signal
		GND		
		EVENT	HC-1.5KAT	
		FREQ	CONT socket	
IN UHF(SO239)	PL259	TRX	ANT of Transceiver	Coax Cable
OUT UHF(SO-239)	PL259	Antenna	Antenna or Tuner Input	Coax Antenna Cable
CONT D-SUB15R	D-SUB15P	Band Data	Band data terminal of transceiver	See Section 10. for details

7-2 Technical Information

Equivalent Circuit of SEND Terminal

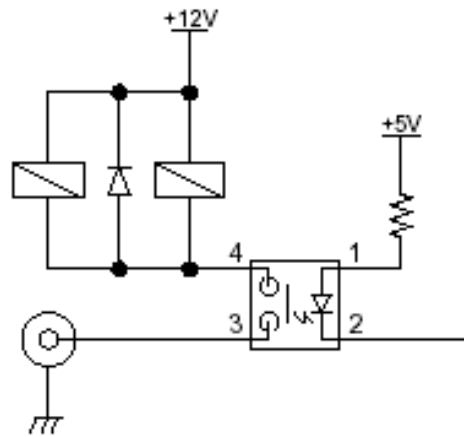

Equivalent Circuit of ALC Output

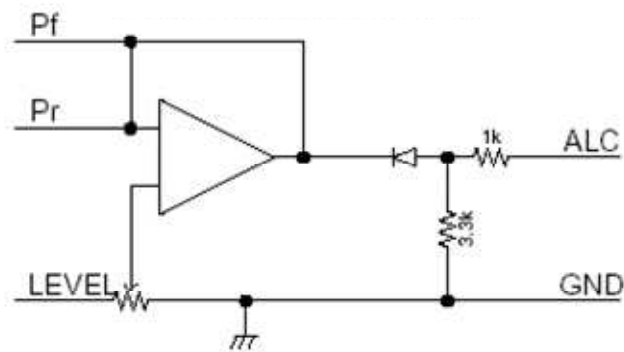

8. Operation

*****CAUTION:** Under the Manual Band Set operation, always be sure to check if BAND Switch position matches that of your radio before keying PTT or the CW paddle. Also when you have changed the BAND, do not make the full power CW (carrier) drive but reduced level power to see if the BAND is set correctly and the amplified RF power comes out properly. **Full power CW drive under the BAND Mis-set leads to the failure of the valuable final power FET devices.** ***

8-1 Various Status

There are four modes to be displayed on LCD.

STBY (Standby Mode)



This mode is for AC Power ON, and OPER. Switch at STBY position. Amplifier is in a through state.

OPER (Operate) Mode



This mode is for AC Power ON, and OPER switch at OPER. Position. Amplifier will work, if the transceiver is keyed.

ONAIR (On Air) Mode



This is for amplifier being keyed under OPER. Mode. Amplifier is amplifying or ready to amplify the drive signal.

PROT (Protection) Mode



Amplifier has been shut down by the protection circuit and is in a though state.

See page 19, Section 11. *Protection Circuits* on how to reset.

8-2 How to Operate

8-2-1 Connect AC cord and coax cables as illustrated in Section 7 *Connection*. Connect the cable from "SEND" to ACC or the remote terminals of transceiver, where it is marked "SEND" or "TX GND". These terminal pins are shorted to ground when the transceiver is in TX/ON AIR mode. If these connections are not made, the amplifier will not go into TX (amplification) mode. For a temporary check to the amp, ground the SEND center pin by inserting an RCA plug whose center pin has been soldered to the outer case of the plug with a small piece of wire. As a side note, this SEND terminal shows 12 VDC when open, and draws 35 mA when shorted.

8-2-2 At first, turn the ALC knob full clockwise to avoid ALC voltage to the transceiver. Application of ALC will be covered in the following Section 9.

8-2-3 Keeping the POWER (AC mains) switch off, check the SWR of your antenna by keying the transceiver to TX mode (CW or RTTY mode). Monitor the SWR with an external SWR/Power meter. If SWR is 1.8 or higher at band center, the antenna has to be adjusted for lower SWR.. As an alternative, an antenna tuner may be inserted.

8-2-4 While keeping OPER/STBY switch at STBY position, turn the POWER switch on. Turn BAND AUTO-MAN'L switch to AUTO, or MAN'L(manual) position. If MAN'L is selected, turn BAND-MAN'L switch to desired band. See page 17, Section10. *Band Data Cable Connection*, for more details of various band data cables. Turn the STAND-BY switch to OPER (operate) position and the amplifier is ready to go. If the POWER switch is turned on, while OPER/STBY switch is at OPER(operate) position, the orange OPER lamp will blink, and you will need to reset the OPER switch to enter into operation mode. "PSE STBY OPERSW is displayed at this time. If you key the transceiver with the carrier level set relatively low (such as 20-30W), you will achieve an amplified output signal of a few hundreds watts. Monitor this output with the PF meter or with an external power meter. Increase drive level to roughly 50W and see if the antenna SWR stays constant. (As higher RF currents flow some antennas may show a changed SWR value due to heated connector junctions and trap coils.)

8-2-5 You can now increase the drive level to nearly 80-90W to achieve maximum carrier output power of 1.4 kW (CW, RTTY) from the amplifier. If you change to SSB mode, peak voice power will reach approximately 1.5 kW. For high duty cycle transmissions like RTTY, SSTV, or FM modes, it is recommended you reduce the drive power by 20-30 % compared with SSB/CW.

8-2-6 With a high power transceiver in SSB mode, you can overdrive the amplifier resulting in a distorted output signal. This can also occur if you speak too loud or if you set the microphone gain too high. Speak into the microphone properly to reduce the possibilities of splattering into the neighborhood. The ALC is effective in preventing the output signal from being distorted or to limit the carrier level to within rated output levels. As long as you do not overdrive, you can disregard the ALC connection. See page 15, Section 9. *ALC Connection* for details.

8-7-7 Protection circuits may work during operation depending on the conditions. If the protection circuit has shut down the amplifier, check the antenna SWR, Vd, AC line voltage, or try to reduce the drive level. To reset, turn off the OPER/STBY switch once, then back on again. Note that some protection modes need to reset the POWER switch(See page19, Section 11. *Protection & Safety Circuits* for more details). The power transformer has an overheat protection(130 °C) in the coil layer. If this temperature switch activates, the amplifier will put you in receive mode with the cooling fan operating until the transformer has cooled off. It may take ten to fifteen minutes to cool, depending upon room temperature. In the same way, there is a built-in thermal switch (100 °C) in the heat sink block of power FET's.

9. ALC Connection

ALC voltage is available at the terminal marked ALC (RCA phono jack) on the right upper corner of the rear panel. Negative maximum DC voltage of ten volts (-10 V) is produced at this terminal when the amplifier is fully driven. This voltage is adjustable with the ALC ADJ. knob located above the ALC jack. If the ALC voltage is properly fed back to the transceiver, you can keep the maximum output power constant or hold the power at a certain level. Also ALC is useful in avoiding your SSB signal from being distorted when overdriven. You may not

always need to connect ALC to the transceiver, if you set the mic gain properly and do not overdrive the amplifier. Depending upon the manufacturer of the transceiver, the suitable ALC voltage differs. ICOM may need 0--4 V, and Yaesu may need 0--5 V range.. Kenwood may need -6--8 V maximum. Check your transceiver manual.

9-1 Prepare an ALC control cable using the RCA plug supplied in the package. Solder a single wire or (more preferably) a shielded single wire to the center pin of RCA plug and solder the shield braid to the outer side of the plug. Connect the control cable to the “ALC (or EXTERNAL ALC)” jack of the transceiver. External ALC input is sometimes available at one of the pins of the “ACC” socket of the transceiver as well.

9-2 At first, turn ALC ADJ. full clockwise. Drive the amplifier in CW/RTTY mode to full output power. Then turn the ALC ADJ counter-clockwise. Observe the SWR/Power meter at the output, (or Pf of the multimeter). Stop turning the ALC ADJ at the point the power starts to decrease. Or if you wish to further reduce the power, keep turning ALC ADJ until the desired level is achieved. If you further try to increase the drive power you will now see the output power become rather saturated, from these adjustments,
(Maximum ALC voltage produced is -10 V when the amplifier output is over 200 W.)

<REAR PANEL>

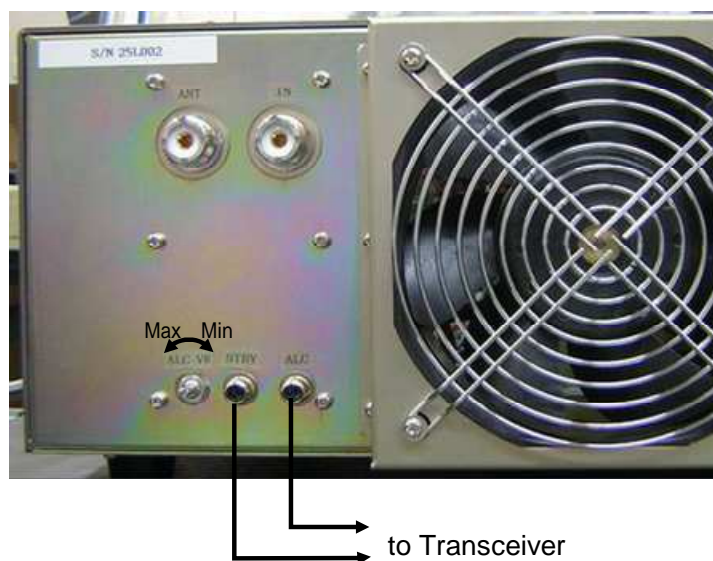

10. Band Data Cable Connection

This section explains about the methods of the auto band setting Collaboration with the modern transceivers of ICOM, Yaesu and Kenwood.

To make this setting, it is needed that the band data cable is connected to “CONT” connector as well as selecting “TRXSEL” for the proper radio manufacturer.

Turn off AC powers of both the amplifier and the transceiver when you connect this data cable. Be sure to confirm the auto band set on each band, after you finish above settings.



Manual Band set



Auto Band set/ CI-V



10-1 ICOM DC Voltage Band Data

HL-2.5KFX Setting

TRXSEL: “I”
 LCD: “ICOM”
 Wiring: Fig. A

Transceiver Setting

None

Caution:

This method fails to discriminate 24 and 28 MHz of WARC bands.

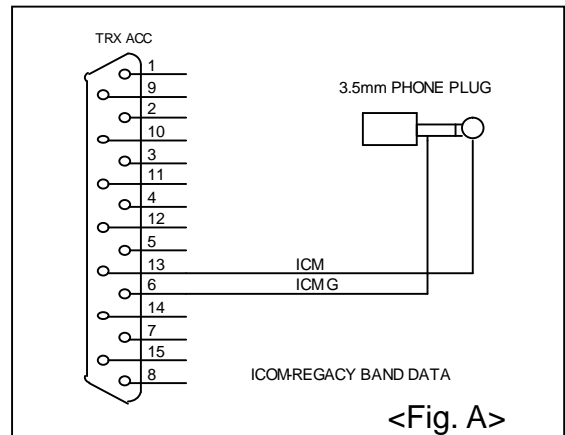

10-2 ICOM CI-V

HL-2.5KFX Setting

TRXSEL: "C"

LCD: "CIV"

Wiring: Fig. B

Transceiver Setting

CI-V BAUD RATE: 9600 [bps]

CI-V ADDRESS: 5 Ch

CI-V Transceiver: ON

CI-V with IC-731: OFF

(See ICOM radio manual for the details.)

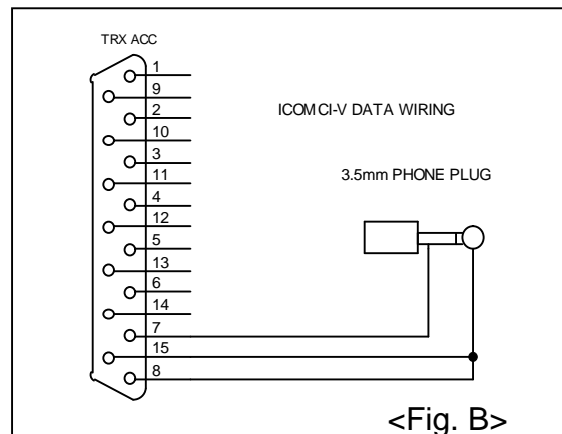

10-3 Yaesu Band Data

HL-2.5KFX Setting

TRXSEL: "Y"

LCD: "YSU"

Wiring: Fig. C

Transceiver Setting

None

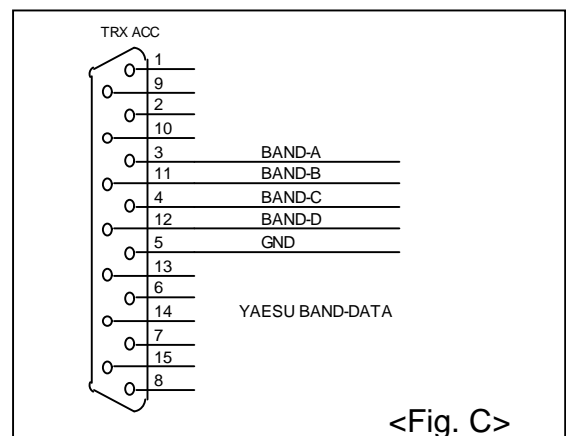

10-4 Kenwood RS-232C

HL-2.5KFX Setting

TRXSEL: "K"

LCD: "KEN"

Wiring: Fig. D

Transceiver Setting

Speed: 9600 [bps]

Stop bit: 1 bit

(See Kenwood radio manual for the details.)

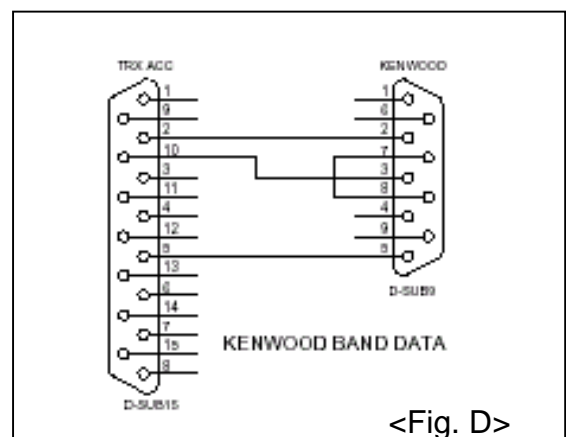

11. Protection & Safety Circuits

11-1 Protection Circuits

HL-2.5KFX is equipped with ten protection circuits as shown in the table below. Protections are commanded by the 16bit microprocessor chip, and DC drain voltage (120 V) is cut off, when the protection circuit works. Also PROT lamp is lit and the amplifier becomes “through” state.

If PROT lamp is blinking, you may reset the shut down with OPER/STBY switch. Reason for the shut down is displayed on LCD panel except for some cases.



Example of LCD display
(In this case, over drive)

For OVER VDD and OVER TEMP shut downs, turn the AC Power switch off and on to reset the amplifier.

No.	PROTECTION	LCD DISPLAY	CONDITION	RESET	REMARKS
1	Over drive	PROT OVER DRIV	Drive exceeded 120 W	*1OPER	
2	Band mis-set	PROT BAND-MISS	Amp gain is less than five times	*1OPER	Or when amp out of order
3	Over current	PROT OVER ID	ID (drain) exceeded 35 A	*1OPER	
4	Freq. Inhibit	PROT INHBT FREQ	Driven freq-ranged 26 to28 MHz	*1OPER	FCC rule
5	Over P _F	PROT OVER P _F	Output power exceeded 1550 W	*1OPER	
6	Over P _R	PROT OVER P _r	Reflected power exceeded W	*1OPER	
7	Over Dissipation	PROT OVER P _{los}	Drain power dissipation exceeded 2000 W	*1OPER	Theoretical
8	Over T _j	PROT OVER T _j	Function temp. reached 190	*1OPER	Theoretical calculation
9	Over voltage	PROT OVER VDD	Drain voltage exceeded 140 V	*2AC POWER	
10	Over heat	PROT OVER TEMP	Heat sink temp reached 90	*2AC POWER	
11	Fuse blown	PROT FUSE-BLOW	Fuse was blown (F1, F2 of Unit 10)	Not resettable	Check Fan Control Unit, Unit 10

*1: Reset OPER/STBY switch.

*2: Reset AC main POWER switch.

11-2 Safety Circuits

In addition to the protection circuits above, there are other safety circuits (inter-locked circuits) built in the amplifier.

They directly shut down AC power line for the primary of the power transformer, and if shut down, AC power lamp (green), LCD display and cooling fan will all go off.

In case this shut down has suddenly occurred during the transmission, stop transmitting first and wait for several minutes. Pull off AC power plug and check whether or not AC main fuses are blown.

- Thermal Switches Threshold
Heat Sink: 100
Power Transformer: 130

These shut-downs will automatically be relieved, when the internal heat cools off. Be sure to turn off AC power switch, before you leave the operation desk. Otherwise AC power will be turned on for itself right after the cooling.

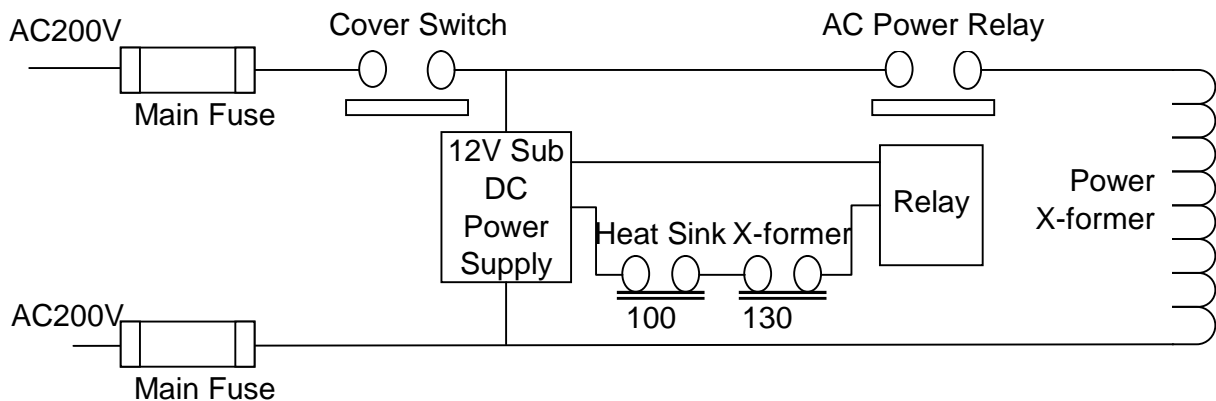

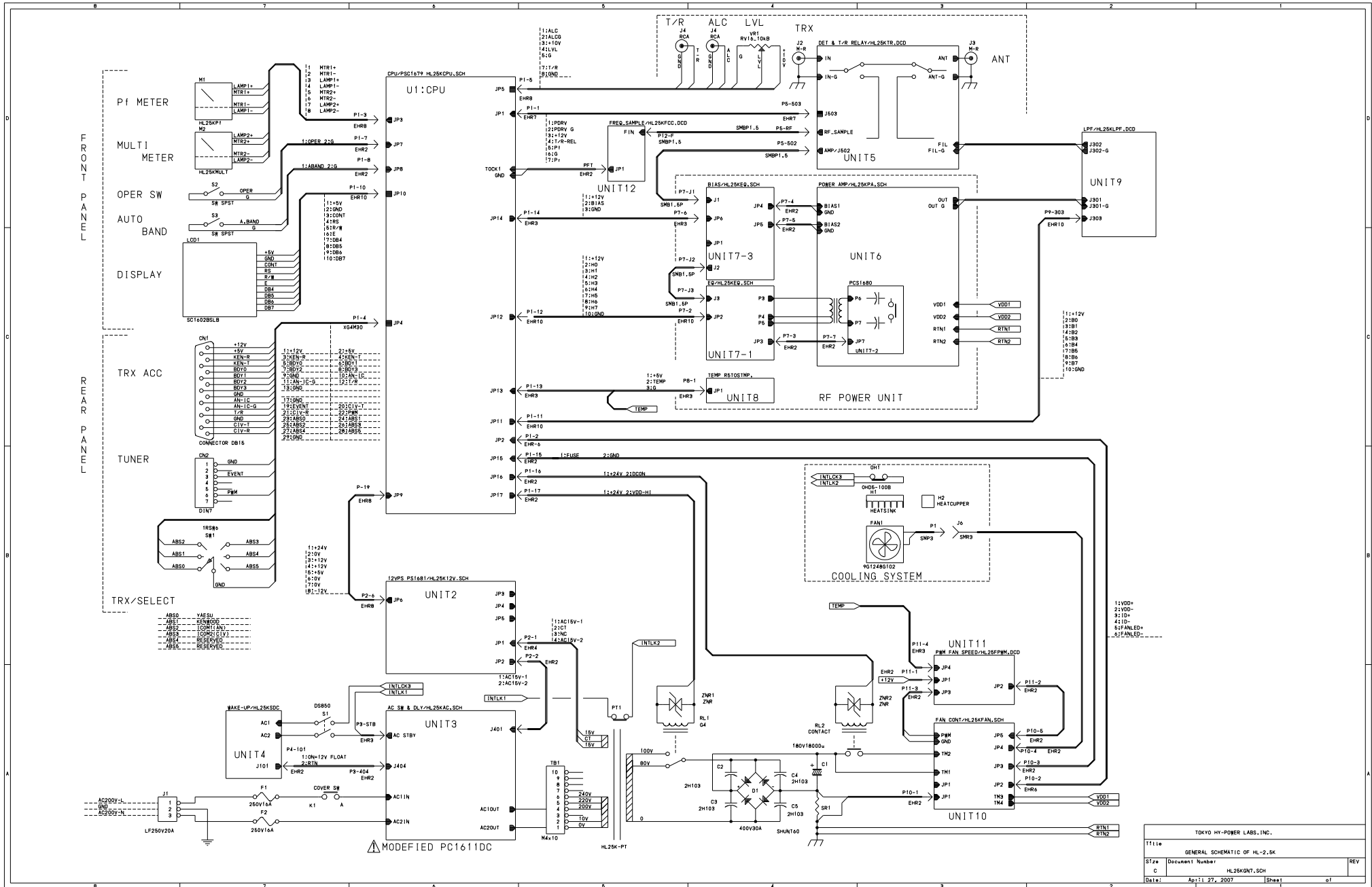

MODIFIED PC1611DC

TOKYO HY-POWER LABS, INC.			
Title	GENERAL SCHEMATIC OF HL-2.BK		
Stz	Document Number:	HL2BKGN7_SCH	REV
C			
Date:	Apr 11 27, 2007	Sheet	of

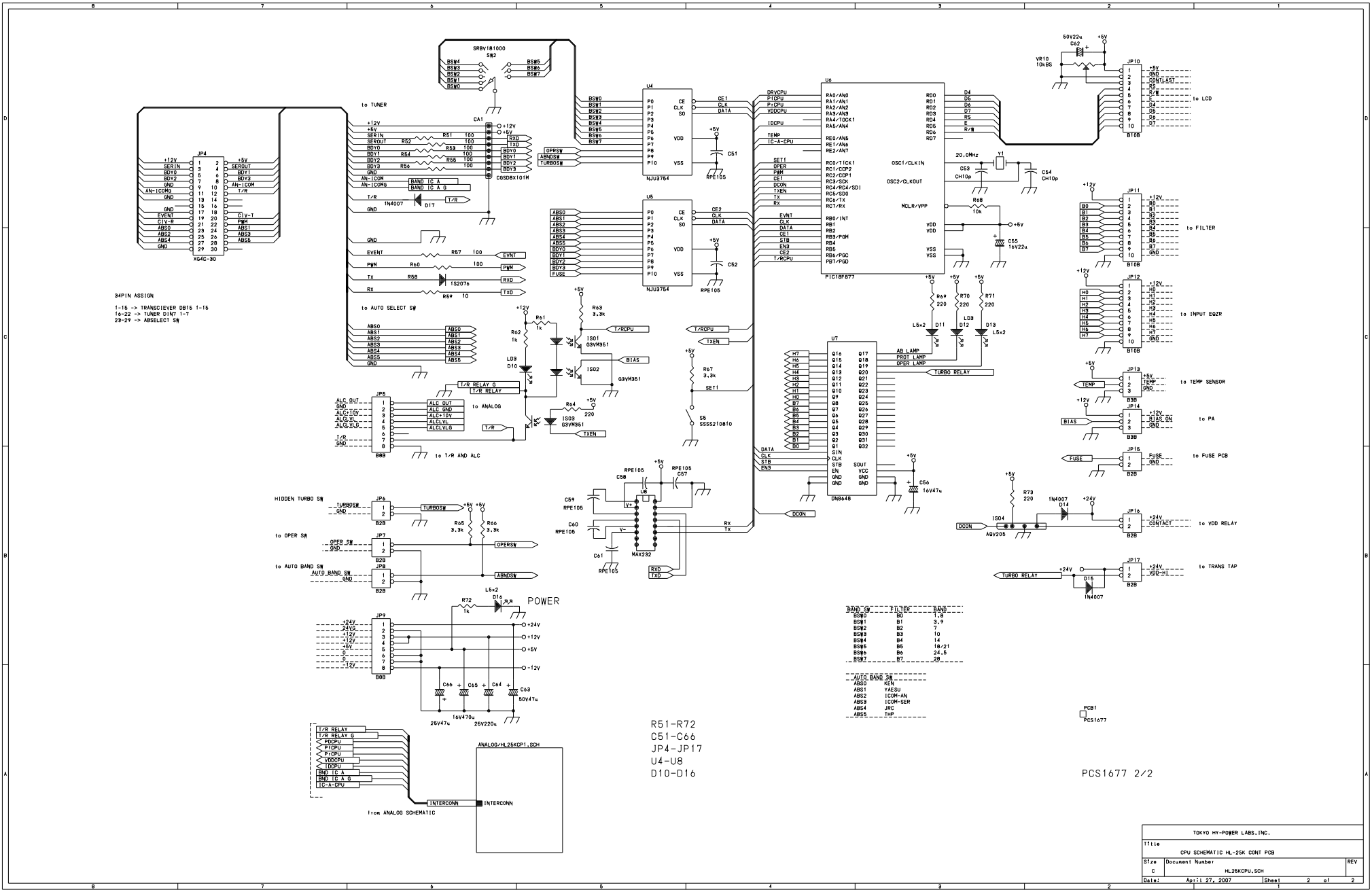

34PIN ASSIGN
 1-16 -> TRANSCIEVER DB16 1-16
 16-22 -> TUNER D10T 1-7
 23-29 -> ABSELECT SW

HIDDEN TURBO SW

to OPER SW

to AUTO BAND SW

POWER

from ANALOG SCHEMATIC

R51-R72
 C51-C66
 JP4-JP17
 U4-U8
 D10-D16

BAND SW	FILTER	BAND
BSW0	B0	1.8
BSW1	B1	3.9
BSW2	B2	7
BSW3	B3	10
BSW4	B4	14
BSW5	B5	18/21
BSW6	B6	24.6
BSW7	B7	30

AUTO BAND SW	KEY
ABS0	KEY
ABS1	YESU
ABS2	ICOM-AN
ABS3	ICOM-SER
ABS4	JRC
ABS5	JIP

PCS1677 2/2

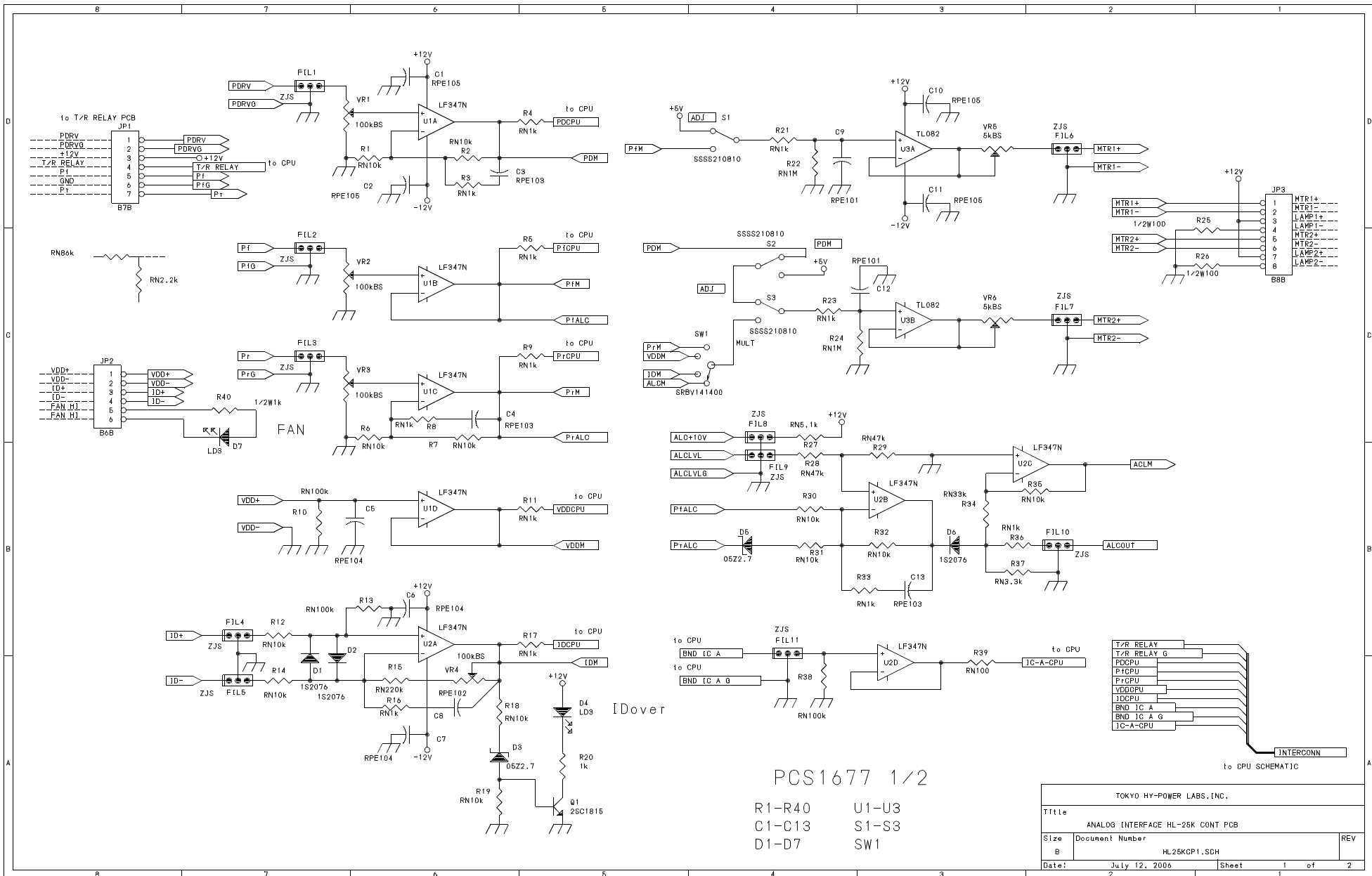

PCS1677 1/2

- R1-R40
- C1-C13
- D1-D7
- U1-U3
- S1-S3
- SW1

TOKYO HY-POWER LABS. (INC.)		
Title		
ANALOG INTERFACE HL-25K CONT PCB		
Size	Document Number	REV
B	HL25KGP1.SDH	
Date:	July 12, 2006	Sheet 1 of 2

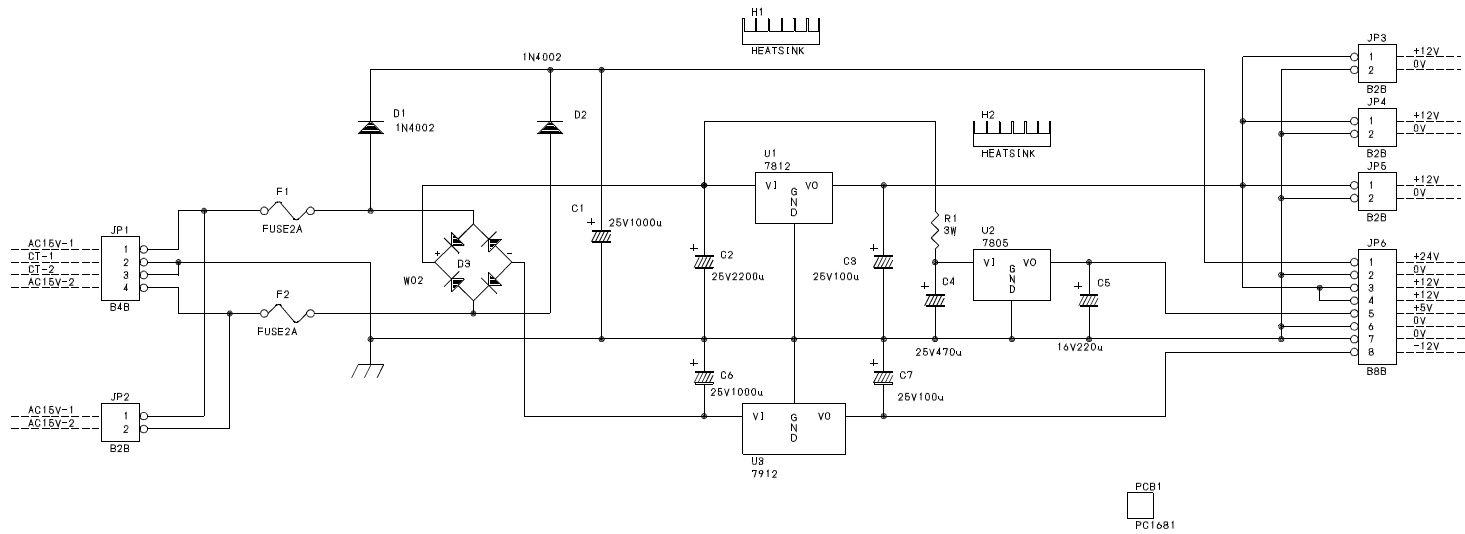

TOKYO HY-POWER LABS. INC.		
Title		
HL-2.5K CONTROL SUPPLY		
Size	Document Number	REV
B	HL25K12V.SDH	
Date:	April 27, 2007	Sheet 1 of 2

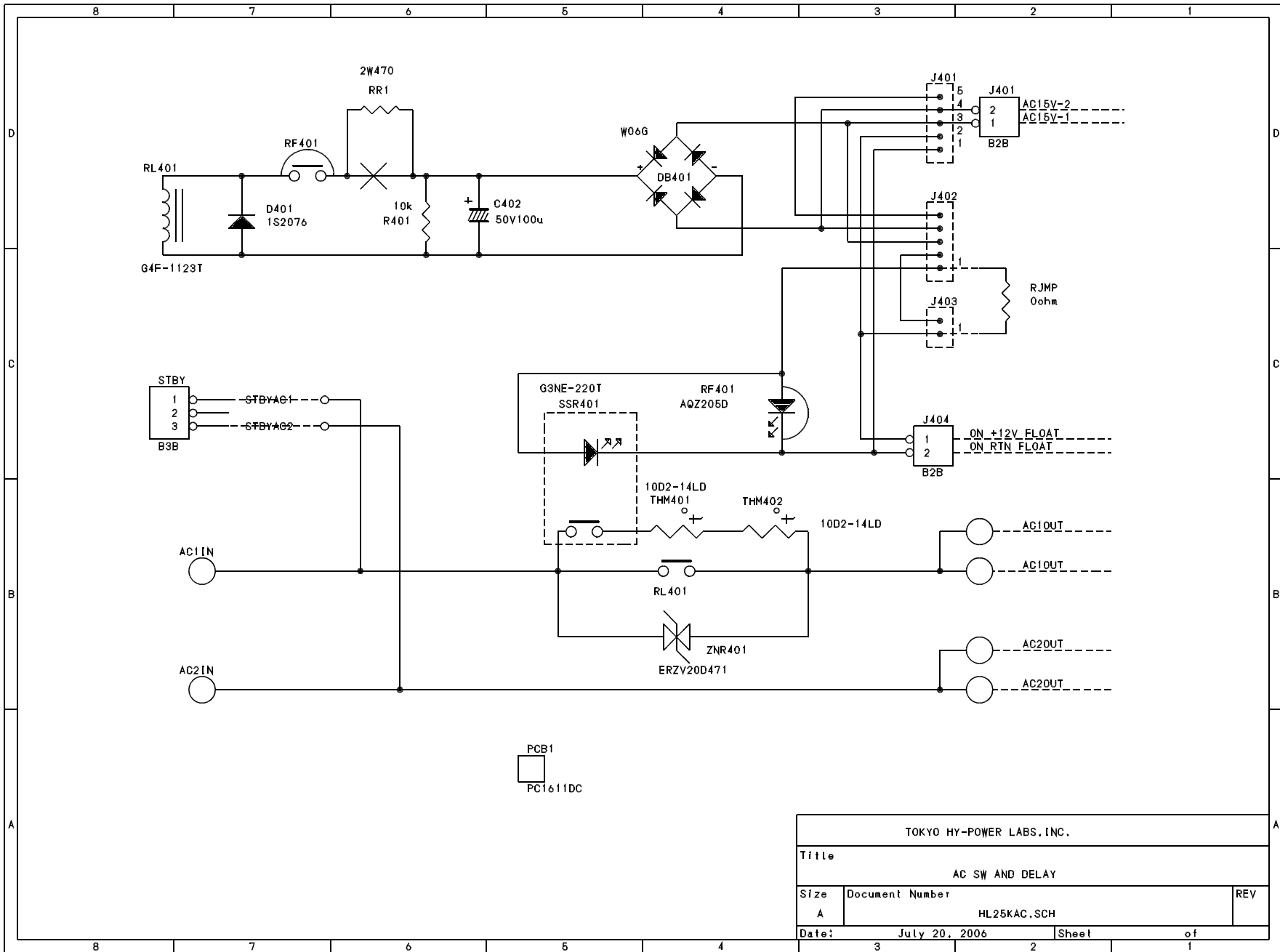

TOKYO HY-POWER LABS, INC.			
Title			
AC SW AND DELAY			
Size	Document Number	REV	
A	HL25KAC.SCH		
Date:	July 20, 2006	Sheet	of
	3	2	1

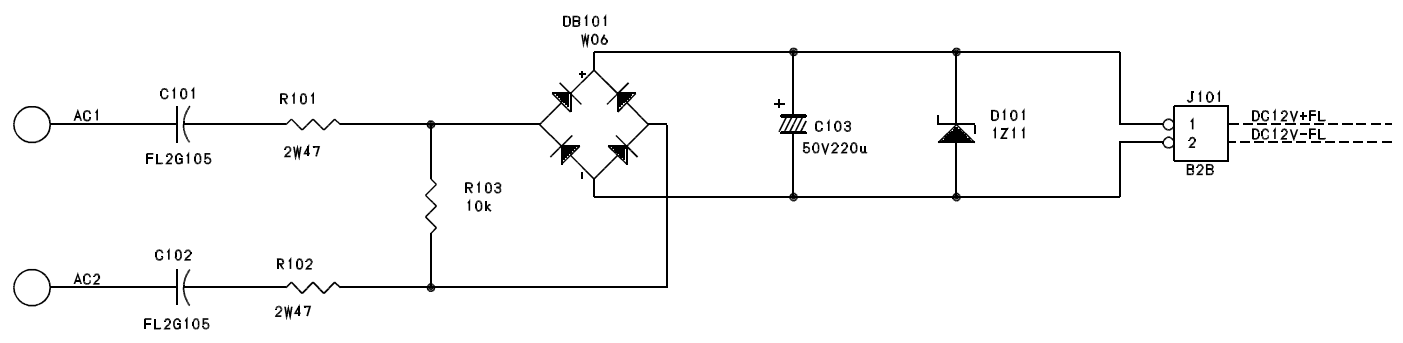

TOKYO HY-POWER LABS, INC.			
Title			
WAKE-UP DC12V			
Size	Document Number		REV
A	HL25KSDC, SCH		
Date:	August 23, 2006	Sheet	of
	3	2	1

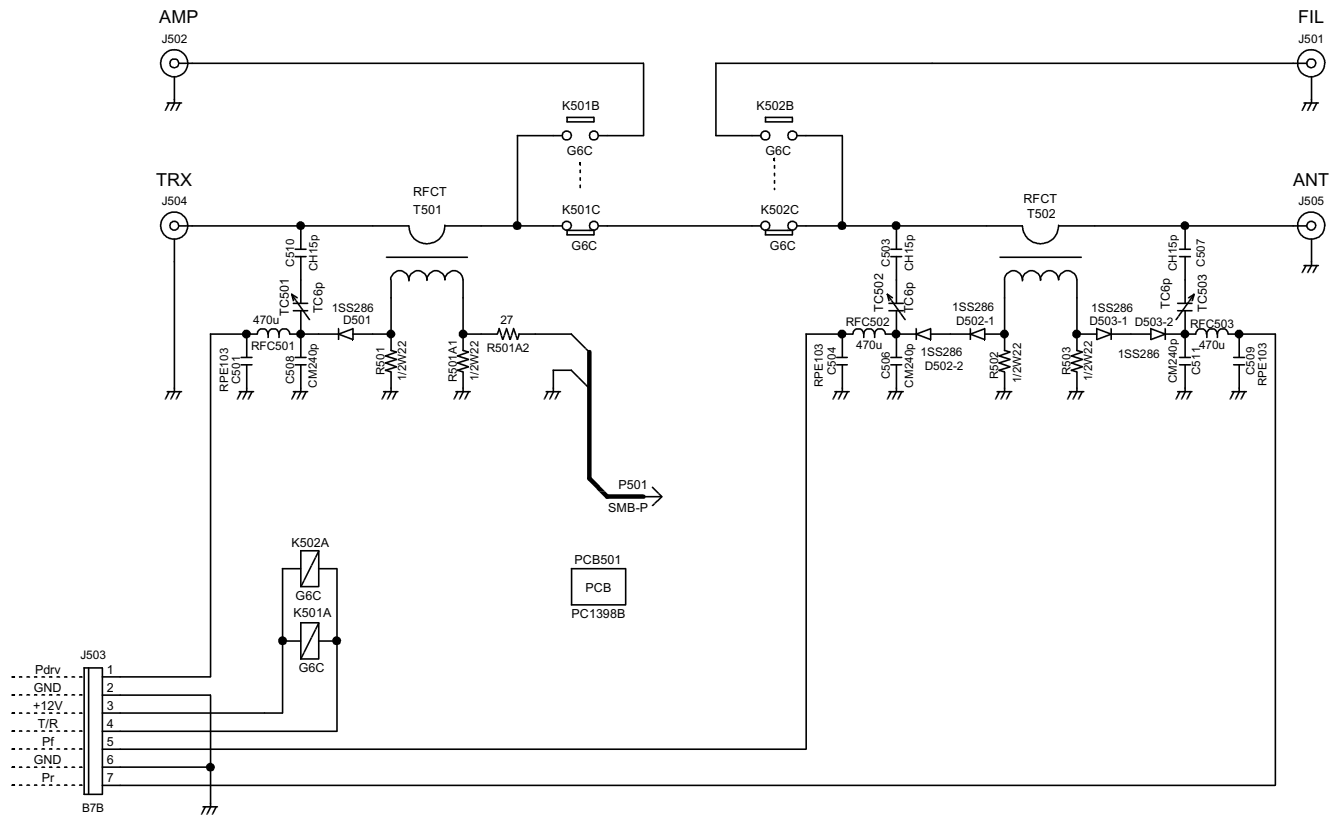

TITLE DET & T/R RELAY FOR HL-2.5K		DRAWING_No. HL25KTR.DCD	
		TOKYO HY-POWER LABS,INC.	
SHEET	DATE	DESIGN	
/	2007, Apr, 04	T.OHSAWA	

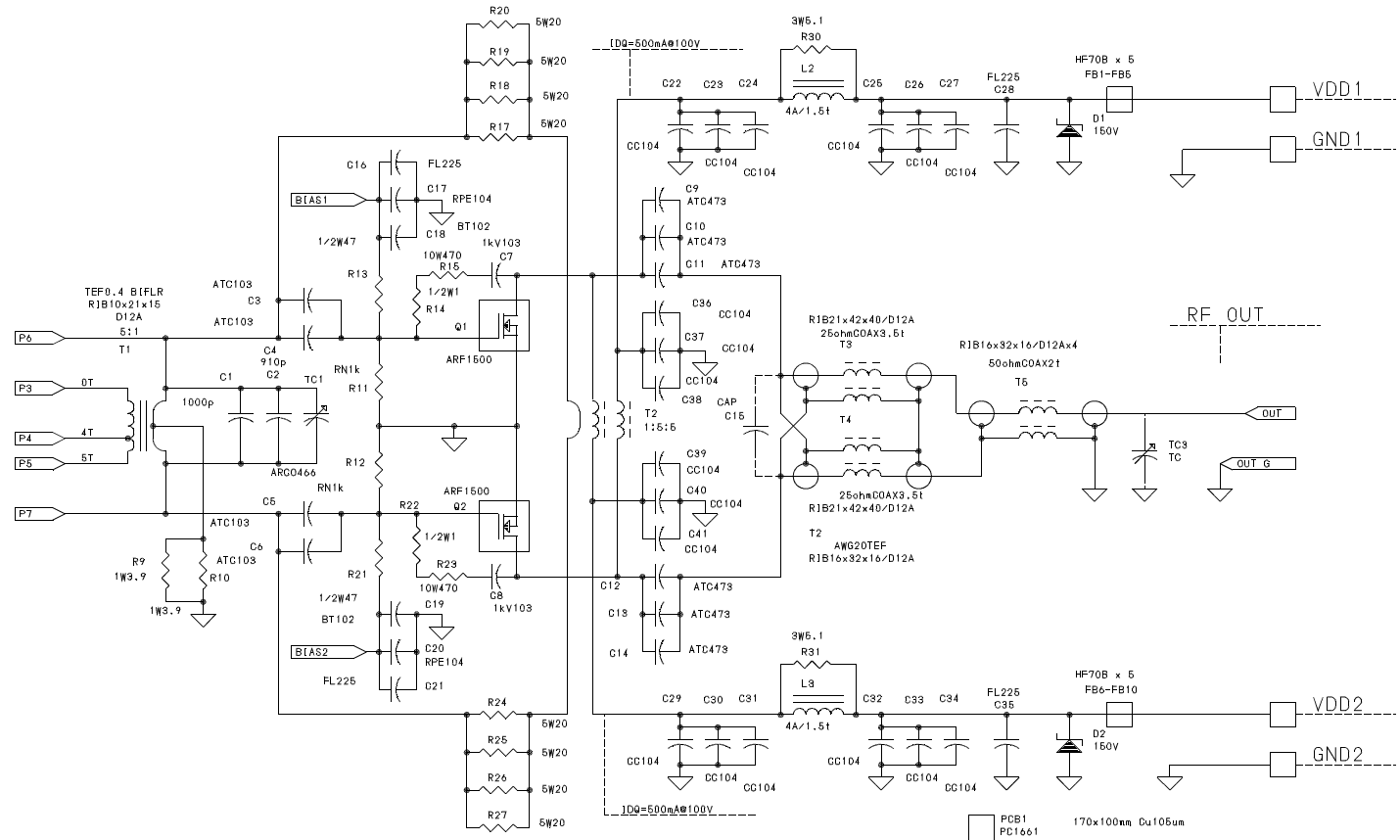

ARF1500 TOP VIEW

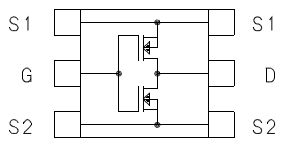

TOKYO HY-POWER LABS. (INC.)		
Title HL-2.5K POWER AMP UNIT		
Size B	Document Number HL25KPA_SGH	REV
Date: July 20, 2006	Sheet 2	of 1

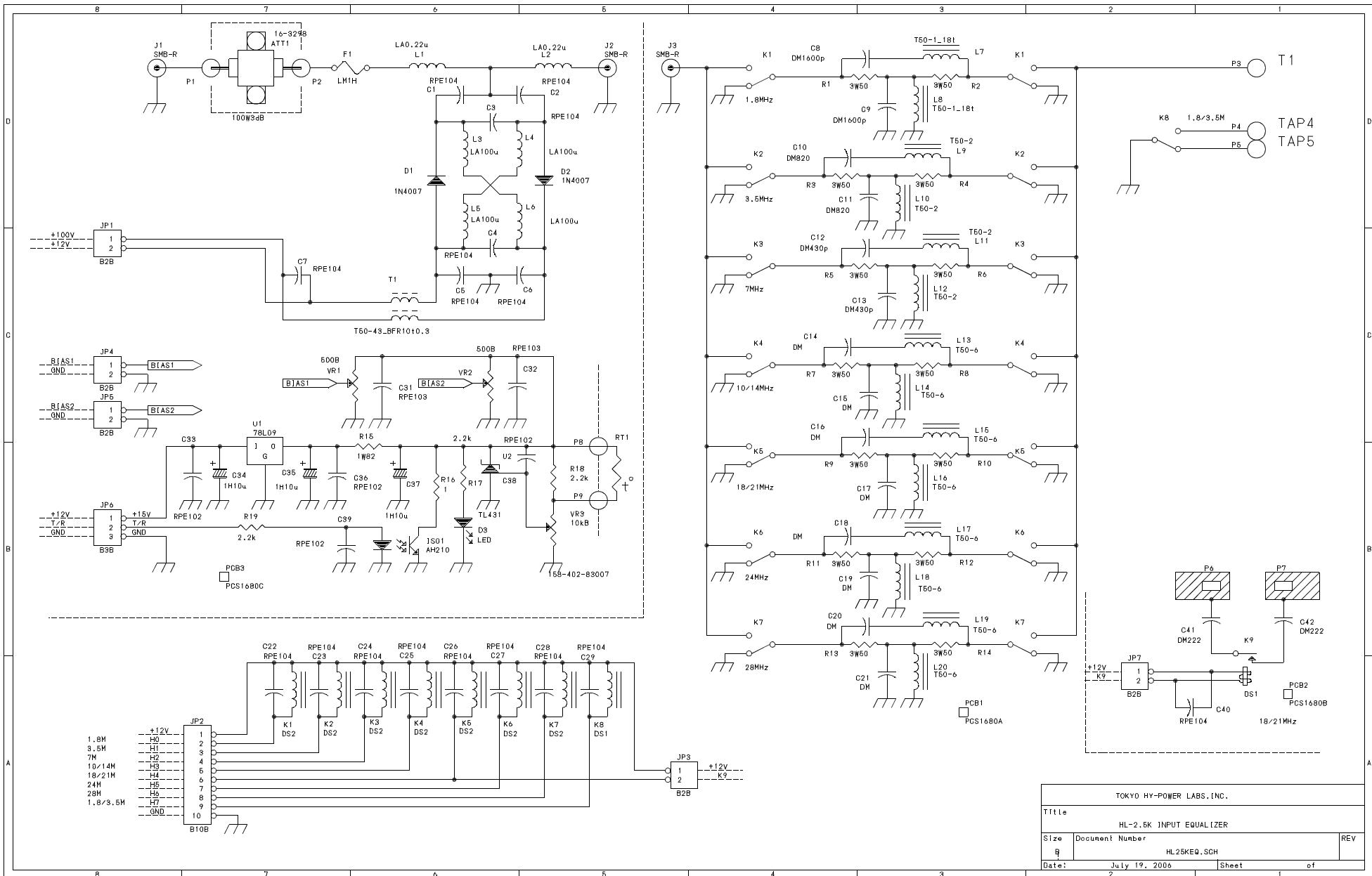

TOKYO HY-POWER LABS. (INC.)		
Title		
HL-2.5K INPUT EQUALIZER		
Size	Document Number	REV
B	HL25KEQ_SCH	
Date:	July 19, 2006	Sheet 1 of 2

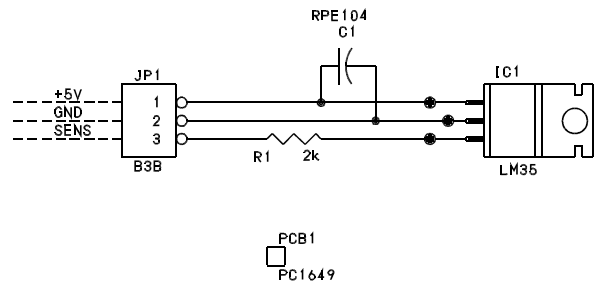

TOKYO HY-POWER LABS, INC			
Title			
TEMP SENSOR UNIT			
Size	Document Number		REV
A	R5T0STMP.SCH		
Date:	May 26, 2005	Sheet	of
	3	2	1

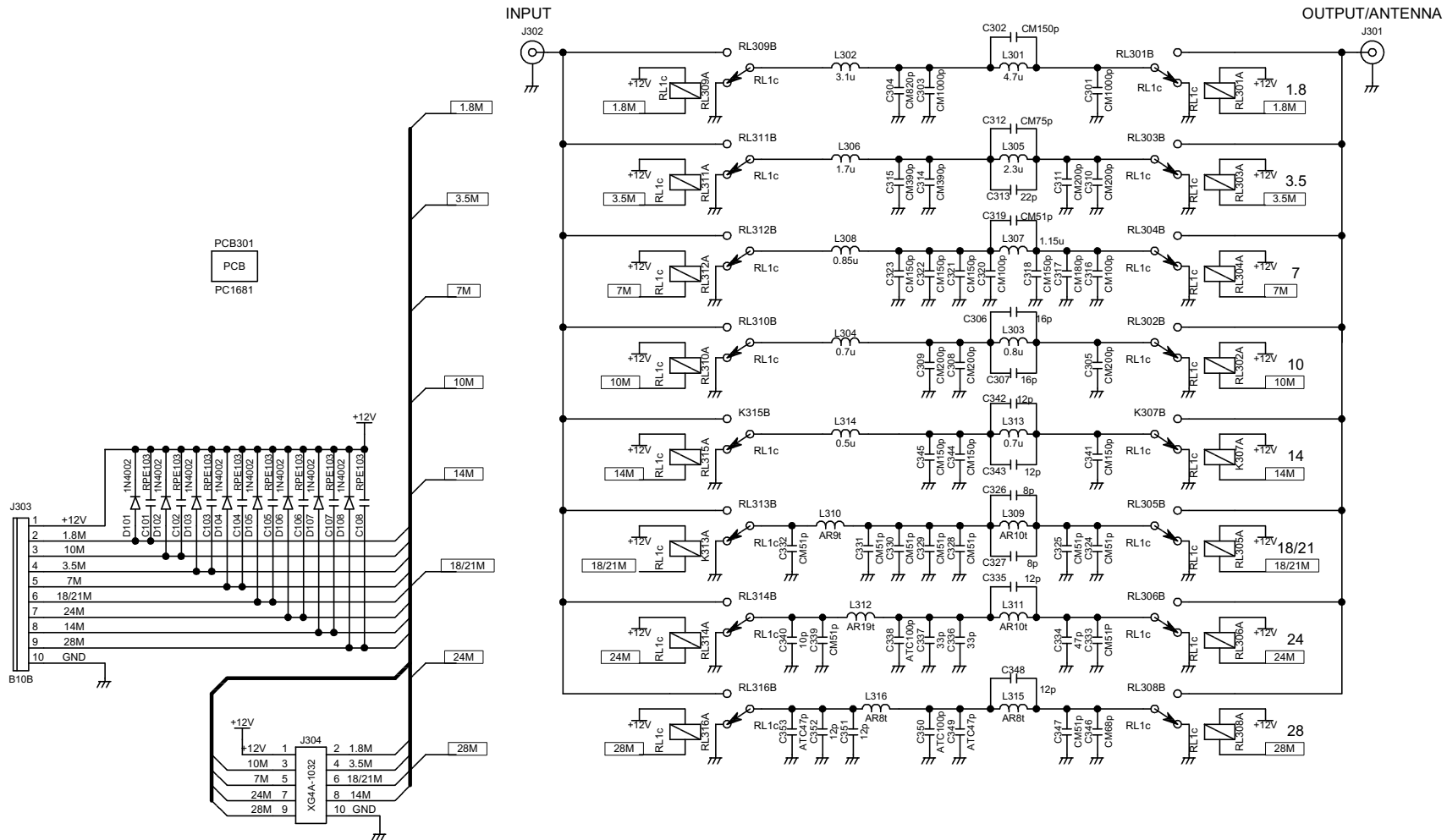

TITLE		FILTER UNIT FOR HL-2.5K		DRAWING_No. HL25KFIL..DCD	
				TOKYO HY-POWER LIBS, INC.	
SHEET	DATE	DESIGN			
/	2007/4/5	T.OHSAWA			

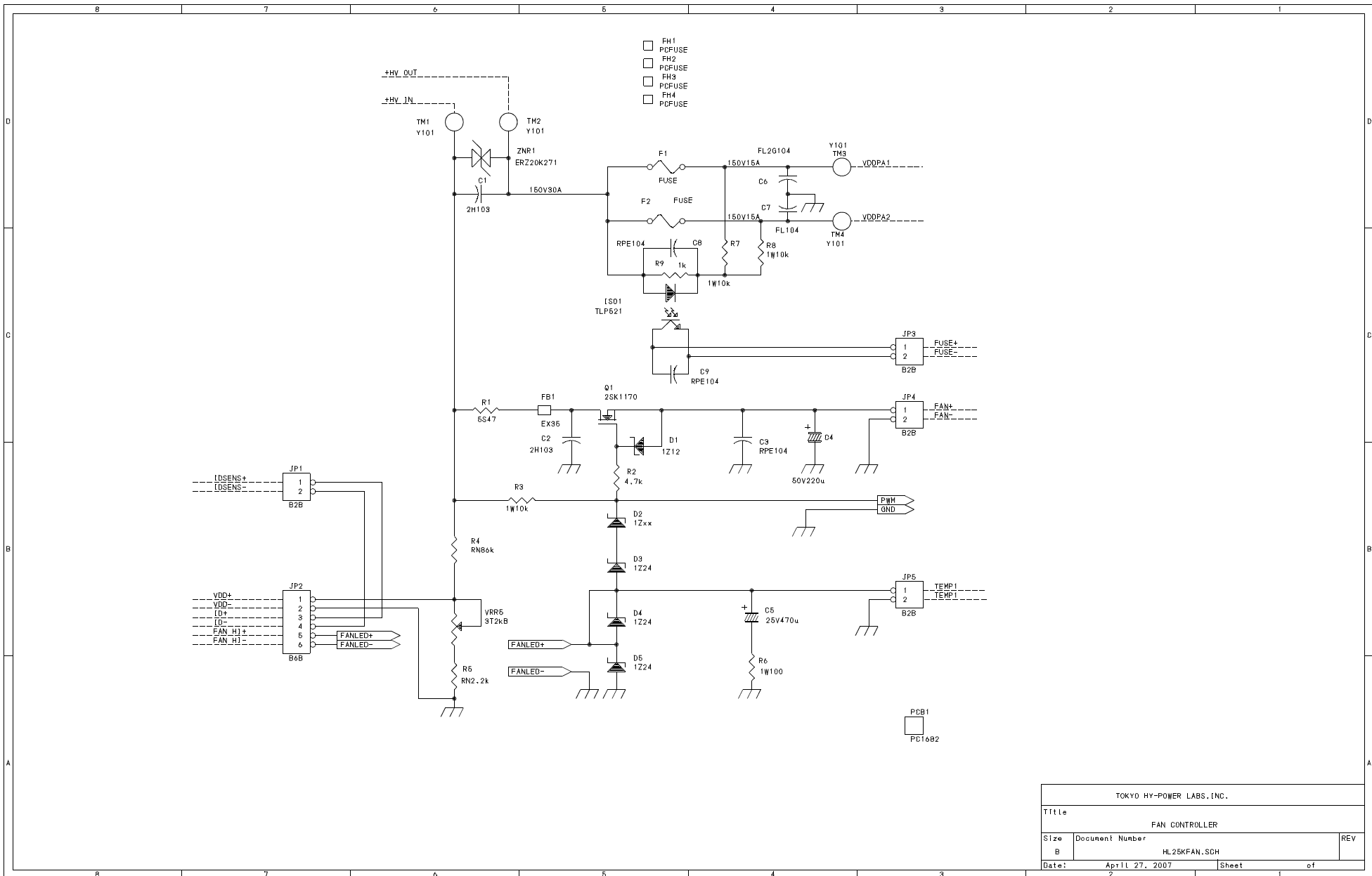

TOKYO HY-POWER LABS. INC.		
Title		
FAN CONTROLLER		
Size	Document Number	REV
B	HL25KFAN.SCH	
Date:	April 27, 2007	Sheet 1 of 2

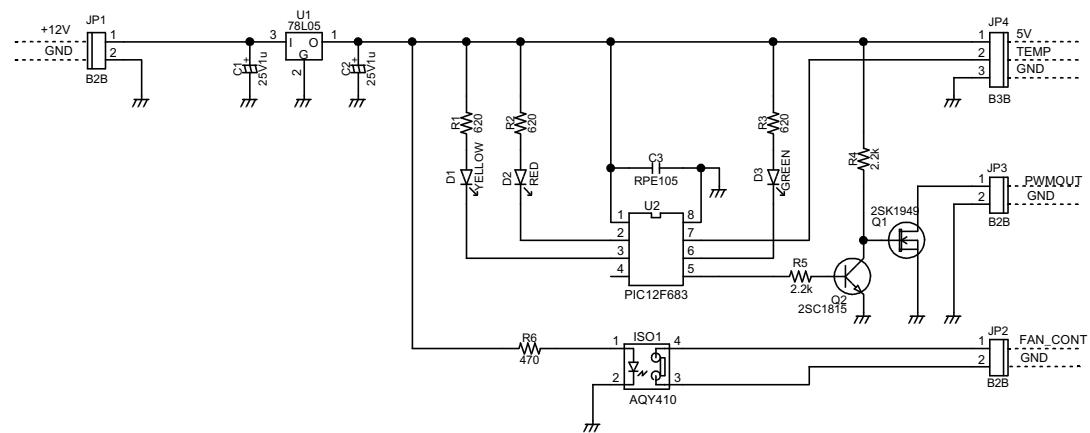

TITLE		PWM FAN-SPEED CONT		DRAWING_No.		HL25FPWM.DCD	
SHEET		DATE		DESIGN		TOKYO HY-POWER	
/		2007,4					

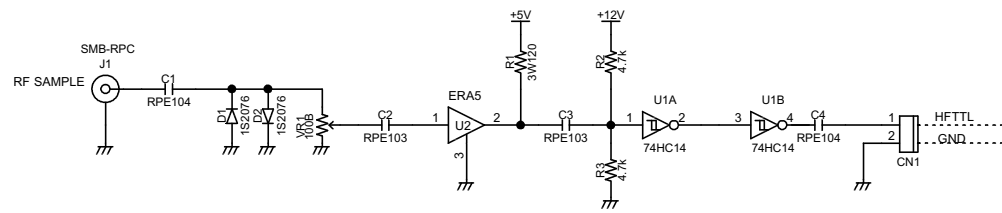

TITLE		FREQ SAMPLE ASSY		DRAWING_No.		HL25KFCC.DCD	
SHEET		DATE		DESIGN		TOKYO HY-POWER	
/		2007,4					