

Users Manual

Solid-State HF/50MHz Band
550W Linear Power Amplifier

Model HL-550FX



1. Introduction

Thank you for purchasing the HL-550FX.

This compact and lightweight desktop HF linear power amplifier has a maximum input power of 1.2kW. Our solid-state broadband power amp technology makes it the smallest and lightest in the industry in its class.

Typical output power is 550W (SSB, CW) with the drive power of 65-90W.

It is best suited for the DX-pedition use due to its light and compact design.

2. Cautions

- 2-1 The amplifier is cooled by forced airflow. Several inches of clearance on the top and the rear wall are necessary to allow for smooth air intake into the fan. Do not block the air vents on the top cover.
- 2-2 Keep the amplifier out of direct sunlight, in a cool dry environment.
- 2-3 Internal high voltages (AC, DC and RF), are present at all times, ON AIR or OFF. Internal access should be limited to avoid injury.
- 2-4 Turn off the AC main power immediately upon any unusual sounds, sights, or odors. Check the multimeter readings of Vd and Id, the fuses and all cable connections around the amplifier. Please notify the dealer or the factory of any problems.
- 2-5 For your safety, do not operate the amplifier without adequate grounding. A proper ground connection will result in peak performance and stability, in addition to reduced RF strays or noises.
- 2-6 To eliminate the RF interference to such home appliances as TV, FM radio, telephone sets, and etc., it is recommended that clamp-on ferrite cores be inserted at both ends of the remote control cable, ALC cable, coaxial jumper cable, and antenna cables, as needed. Also, a common mode AC line filter (near the AC outlet), and in-line low pass filters on the antenna coaxial cable (as necessary), are recommended.

- 2-7 The amplifier has fast acting sophisticated protection circuits. Please note, however, any such actions that cause the same fault to occur repeatedly, will lead to failure of the valuable final power FET transistors.
- 2-8 Before checking inside the amplifier, be sure to wait a few minutes for the high DC voltage to discharge (monitor Vd meter reading). The potentiometers for RF power detector, protection circuits, FET bias voltage circuit, etc., are precisely adjusted at the factory, and should not be altered. Doing so, would require readjustment with precision measuring instruments.
- 2-9 The DC power supply section consists of most efficient and sophisticated switching mode circuit. It accepts the wide AC line voltages ranging from AC 100V up to 260V. Since the line voltage is detected and selected automatically, you do not have to worry about the tap change of internal power transformer whichever country you will travel. Be sure to verify capacity of AC line fuse before you plug the AC power cord into the outlet.
- 2-10 Before starting the amplifier, be sure to connect a dummy load (50 ohms, 550W min.) or a well-adjusted antenna to the output terminal. Operating without any load will cause extreme stress to the RF power FET's, although protection circuits should work under critical conditions.
- 2-11 Required drive power is slightly less than 100W to obtain the full 550W output. Do not attempt to operate with excessive drive from a high power transceiver.
- 2-12 Keep the aluminum heat sink and air openings free from dust and blockages. Periodic cleaning will prevent degraded cooling efficiency.
- 2-13 For long continuous operation in RTTY/FM modes, it is recommended that you reduce the RF drive levels by 20% to 30% lower output than CW/SSB modes.
- 2-14 To prevent damage to the precision electronic components, avoid extreme physical shock to the amplifier. If factory service is required, the amplifier should be shipped using the original box and packing materials.

3. Features

- 3-1 Our solid-state broadband design engineers worked to make the HL-550FX, the lightest and most compact 550W out portable HF/50MHz amplifier in the industry. This world-class compact 550W HF amplifier is the easiest to handle and operate anywhere in the world.
- 3-2 The amplifier's main PA section includes 4 high power MOS FET VRF150, resulting in 550W (SSB/CW max.) on HF and 50MHz bands. The amplifier's broadband characteristics require no further tuning once the operating band is selected.
- 3-3 The amplifier allows operation in full break-in CW mode due to the use of the amplifier's high-speed antenna relays (made by Panasonic).
- 3-4 With the unique duct structure design and the powerful blower fan, the aluminum heat sink block for RF PA module (and other components), are effectively cooled. The fan's quiet operation allows for even the weakest DX signals to be heard.
- 3-5 The amp utilizes a sophisticated circuit to run the various high speed protection circuits such as overdrive, high antenna SWR, DC overvoltage, band miss-set etc.
- 3-6 This amplifier is compatible with wide AC line voltage ranging from AC 100V to 260V. Although AC line voltage is automatically selected, be sure to install proper fuse into AC line fuse holder.
- 3-7 For the safety of the operator, an Interlock system is employed. The AC power is shut down if the top cover is removed, and the automated safety interlock is activated.
- 3-8 An analog multimeter allows the operator to monitor Pf (Forward output power), Pr (Reflected power), Vd (Drain voltage of power FET), Id (Drain current) etc.

4. Specifications

Frequency Band	1.8~50 MHz all amateur bands including WARC bands
Mode	SSB, CW (RTTY)
RF Drive	65~90W typ. (100W max.)
Output Power	550W typ. (RTTY 400W max.)
Drain Voltage	42V
Drain Current	30A max.
Input Impedance	50 Ω (unbalanced)
Output Impedance	50 Ω (unbalanced)
Final Transistor	VRF150 x 4
Circuit	Class AB parallel push-pull
Cooling Method	Forced Air Cooling
Multi-meter (F.S.)	Output Power Pf 1kW Reflected Power Pr 100W Drain Voltage Vd 60V Drain Current Id 50A
Input/Output Connectors	UHF SO-239
AC Power	AC 200~260V, 50/60Hz 7.5A max. AC 100~130V, 50/60Hz 15A max.
AC Consumption	1.3kVA max. when TX
Dimension	232 x 145 x 392 mm, 9.1 x 5.7 x 15.4 inches (WxHxD)
Weight	Approx. 9.2kgs. or 20.3lbs.
Accessories	AC Power Cord x 1 Coax Jumper Cable (with PL259's) x 1 RCA Plug x 2 Spare Fuse 8A x 2 (for AC200V line) Spare Fuse 15A x 2 (for AC100V line) Spare Fuse 15A x 2 (for F202, F203 of PC1662V power amp board) Spare Fuse 1A x 1 (for PC1662V power amp board) (miniature fuse) Spare Fuse 3.2A x 1 (for PC1819 sub AC control board) (miniature fuse) Users Manual

5. AC Line Voltage

- 5-1 Although the amplifier is designed to work with both AC 115V (100-130V) and AC 230V (200-260V), for stability we recommend operation from AC 230V.
- 5-2 The correct AC plug (not included in the package) must be obtained locally due to the AC plug variations worldwide.
- 5-3 The AC line fuse has been factory preset for 115V use (or as requested by the customer at the time of order). If you wish to change to AC 230V, change the fuse to 8A. For your safety, before making this change, be sure to pull the AC plug from the AC outlet to avoid injury.

NOTICE

Please note the followings when you are using
AC100V line (AC100V~120V).

**NEVER EXCEED OUTPUT POWER OF 500W,
WHEN RUNNING THE AMP FROM AC100~120V LINE.**

Otherwise, over-current protection completely shuts down the drain voltage power supply for five minutes before it gets resettable.

When this protection works, O.DRIVE lamp lights and HL-550FX will enter the through state, the reset of the amp being disabled for five minutes.

To restart the amp, turn the POWER switch OFF, and wait for 5 (five) minutes. Then turn the power ON.

If the protection works too often, please take one or all of the following measures.

- ① Lower the drive power of the transceiver.
- ② Connect the ALC line. Adjust the ALC Output Adjustment Knob on the rear panel so that the drain current (ID) will never exceed 25.0A on any frequency.
- ③ Change to AC200~240V line.

6-A. Front Panel Description

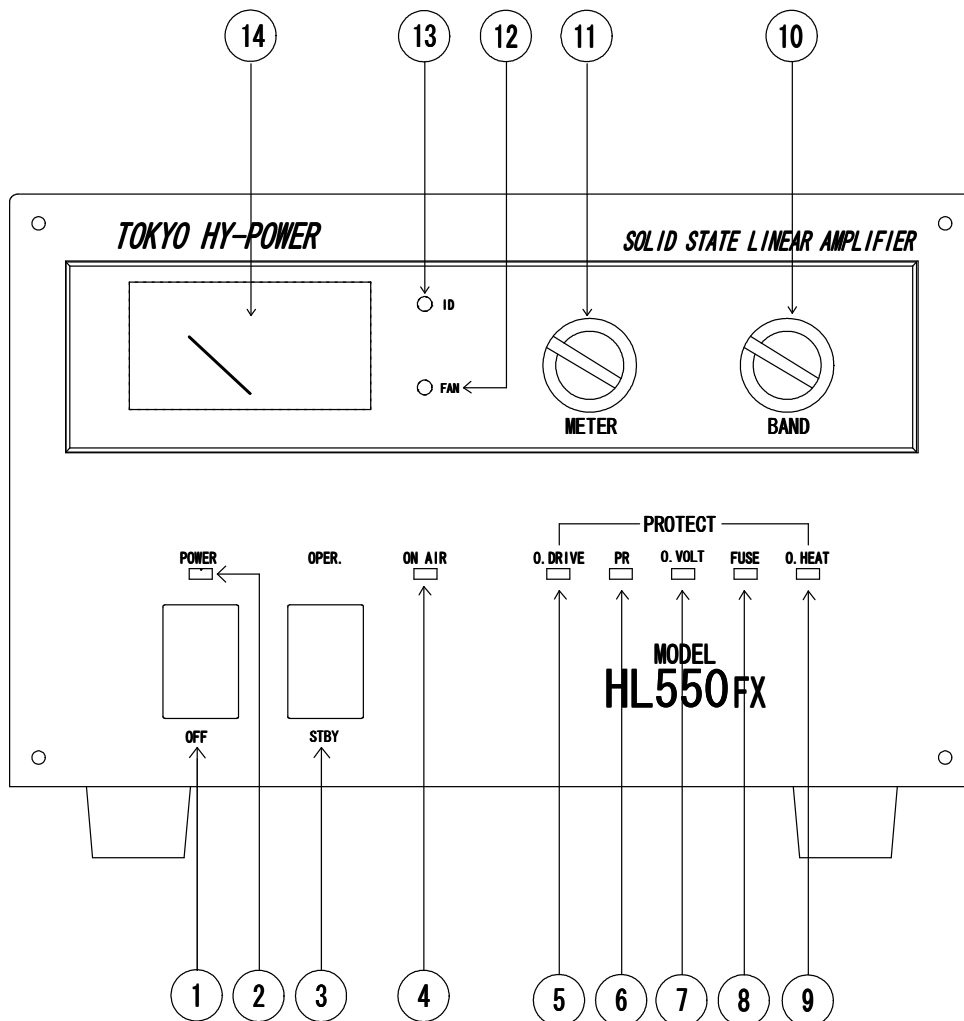

- ①**POWER** : Main power switch to turn AC power on and off.
- ②**POWER (LED)** : Green LED lights when power is turned on.
- ③**OPER.** : OPERATE/STAND-BY switch. At OPERATE, the amplifier is ready to go into ON AIR (TX) mode and at STBY, it is on STAND-BY mode.
- ④**ON AIR (LED)** : Green LED lights when the amplifier is in transmit (TX) mode.
- ⑤**O.DRIVE (LED)**: When overdrive or band miss-set is detected, LED lights to indicate the protection circuit has worked.
- ⑥**PR (LED)** : LED lights when reflected power from antenna exceeds 70W to indicate protection circuit has worked.
- ⑦**O.VOLT (LED)** : When the DC drain voltage of the FET (Vd) is too high, the LED lights to indicate the protection circuit has worked.
- ⑧**FUSE (LED)** : LED lights when the 15A glass fuse has blown from excessive Id. (Two fuses are on the PC1622V PA board.)

⑨**O.HEAT (LED)** : When the PA module temperature reaches 80 deg.C, the LED lights to indicate the protection circuit has worked. (It is necessary for the cooling fan to operate for several minutes to cool the PA module.)

(Turn the main POWER switch to off, and then on again to reset the Protection Circuits.)

⑩**BAND** : Select the desired operating frequency band.

⑪**METER** : To change the multi-meter scales. Meter reads Pf, Pr, Vd, and Id.

⑫**ID (LED)** : LED lights when the input drain current is over 20A. This does not mean that any damage occurred to the amplifier, but is useful for the user to notice any stress influencing the final FET caused by high drain current, load impedance trouble, etc. We recommend that you note the usual condition of the lighting. When any unusual symptoms are noticed, the user may lower the drive power from the transceiver, check the antenna SWR, etc.

⑬**FAN (LED)** : LED lights when fan is running at high speed. When the heatsink reaches 50°C the cooling fan will switch to high-speed mode to cool the heatsink.

⑭**MULTIMETER** : Pf (Forward output power), Pr (Reflected power from antenna), Vd (FET drain voltage), and Id (FET drain current) are shown on the scale as selected by ⑪METER select switch.

6-B. Rear Panel Description

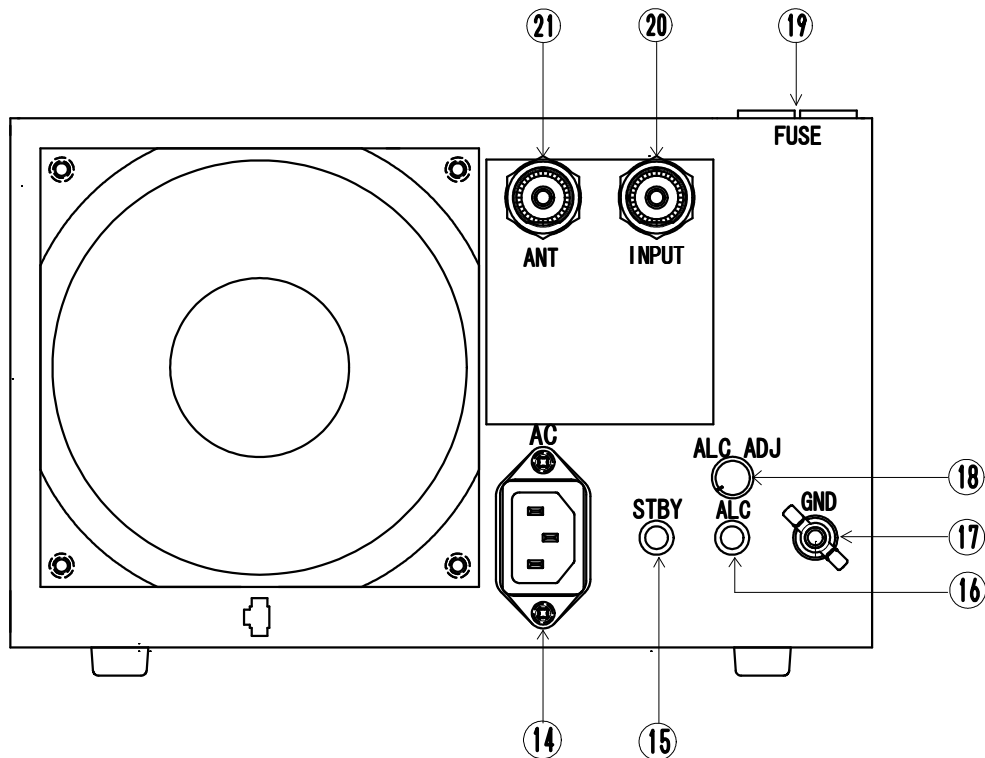

- ⑭AC POWER** : AC Mains Socket. Socket for the AC power cord. (Socket is EMI filtered.)
- ⑮STBY** : RCA Jack. Connect the control cable from the ACC terminal (or SEND, TX GND etc.) of the transceiver. The center pin is to be shorted to ground through the relay circuit of the transceiver. The DC current necessary is 5V, 1mA only.
- ⑯ALC** : RCA Jack for ALC Voltage Output. Negative DC voltage appears at the center pin, which is fed back to the ALC terminal of the transceiver. ALC is used to keep the amplifier output power at certain limits. Also it is useful when the transceiver output power is higher than 100W. (See page 12, 8.ALC Connection). Also consult your HF/50MHz transceiver's user manual.
- ⑰GND** : Ground Terminal
- ⑱ALC ADJ** : Potentiometer to adjust ALC voltage level. Minus 10V is available at maximum, when turned full counter-clockwise. Factory setting is 0 volts, with the pot turned full clockwise.
- ⑲FUSE** : A pair of fuses for AC mains. 15A glass pre-installed fuse. (Change to 8A fuses if 230V line is used.)
- ⑳IN PUT (TX)** : RF Input Connector. Connect the coax jumper cable from the transceiver.
- ㉑ANT (OUTPUT)** : RF Output Connector. Connect the coax cable to the antenna.

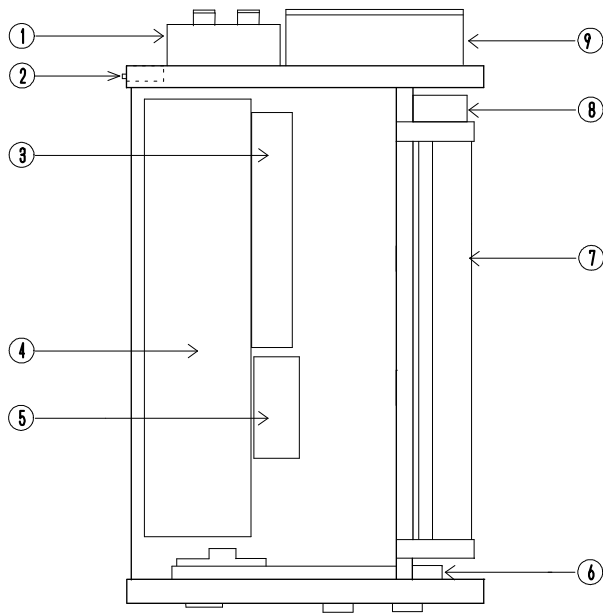

Inner Layout of HL-550FX

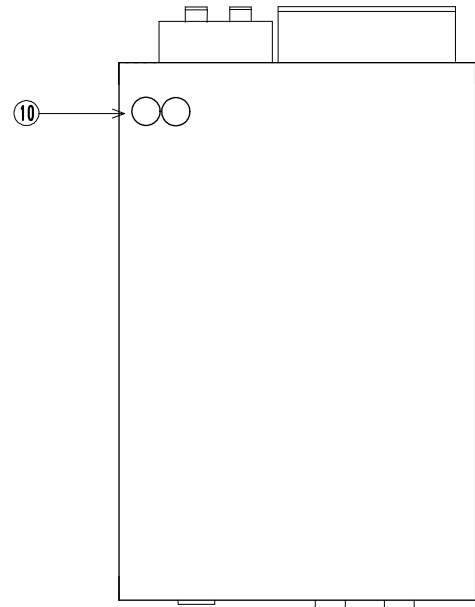

Upper View

- ① RF Power Detector and Send-Receive Switching Relay
- ② Inter-lock Switch
- ③ LPF Board
- ④ Main Power Source Unit
- ⑤ Sub-Power Source Unit
- ⑥ Control Board
- ⑦ Power Amp Unit
- ⑧ Frequency Detector Board
- ⑨ Cooling Fan
- ⑩ AC Fuse

7. Connection and Operation

This section explains a one-antenna system connected to the transceiver and an external SWR/POWER meter.

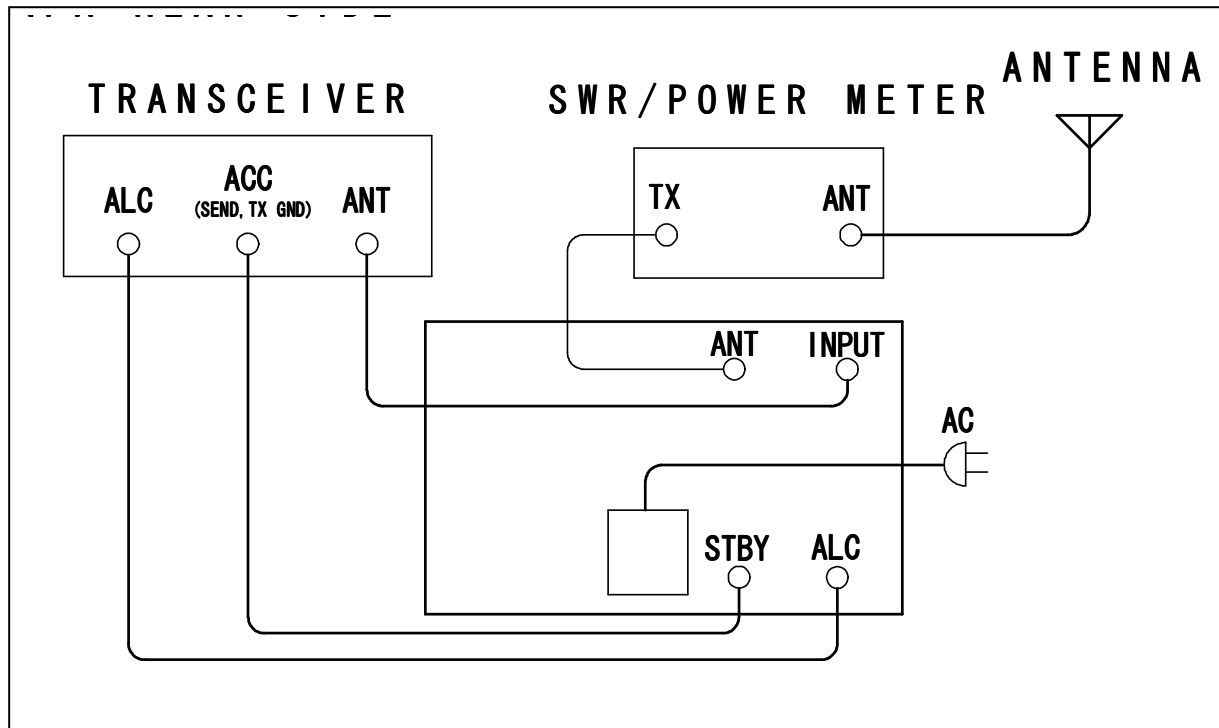

HL-550FX REAR SIDE

- 7-1 Connect AC cord and coax cables as illustrated above. Connect the cable from “SEND” to ACC or the remote terminals of transceiver, where it is marked “SEND” or “TX GND”. These terminal pins are shorted to the ground when the transceiver is in TX/ON AIR mode. If these connections are not made, the amplifier will not go into TX (amplification) mode. For a temporary check to the amp, ground the STBY center pin by inserting an RCA plug whose center pin has been soldered to the outer case of the plug with a small piece of wire.
- 7-2 At first, turn the ALC knob full clockwise to avoid ALC voltage being fed to the transceiver. Application of ALC will be covered in the following Section 8. ALC CONNECTION.
- 7-3 Keeping the POWER (AC mains) switch off, check the SWR of your antenna by keying the transceiver to TX mode (CW or RTTY mode). Monitor the SWR with an external SWR/Power meter. If SWR is 1.5 or higher at band center, the

antenna has to be adjusted for lower SWR. As an alternative, an antenna tuner may be inserted.

- 7-4 Turn the POWER switch on. Turn the BAND switch to a desired operating frequency band. Turn the STAND-BY switch to OPER (operate) position and the amplifier is ready to go. If you key the transceiver with the carrier level set relatively low (such as 20-30W), you will achieve an amplified output signal of a few hundred watts. Monitor this output with the multimeter (at the Pf position) or with an external power meter. Increase drive level to roughly 50W and see if the antenna SWR stays constant. (As higher RF currents flow, some antennas may show a changed SWR value due to heated connector junctions and trap coils.)
- 7-5 You can now increase the drive level to nearly 80-90W to achieve maximum carrier output power of 550W (CW) from the amplifier. If you change to SSB mode, average voice power of a few hundred watts will be observed on the panel meter, Pf scale, while peak voice power reaching a little over 550W. For high duty cycle transmissions like RTTY mode, it is recommended that you reduce the drive power by some 30%.
- 7-6 With a high power transceiver in SSB mode, you can overdrive the amplifier resulting in a distorted output signal. This can occur if you speak too loud or if you set the microphone gain too high. Speak into the microphone properly to reduce the possibilities of splattering into the neighborhood. The ALC is effective in preventing the output signal from being distorted or to limit the carrier level to within rated output levels. It is strongly recommended to make ALC connection, especially when 200W out high power radio is used to drive.
- 7-7 Protection circuits may work during operation depending on the conditions. If the protection circuit has shut down the amplifier, check the antenna SWR, Vd, AC line voltage, or try to reduce the drive level. To reset, turn off the POWER switch once, then back on again. The power transformer has an overheat protection in the coil layer. If this temperature switch activates, the amplifier will put you in receive mode with the cooling fan operating until the transformer has cooled off. It may take ten to fifteen minutes to cool, depending upon room temperature. For more details on this protection circuit, see Section 9. PROTECTION CIRCUITS.

8. ALC Connection

ALC voltage is available at the terminal marked ALC (RCA phono jack) on the right lower corner of the rear panel. Negative maximum DC voltage of ten volts (-10V) is produced at this terminal when the amplifier is fully driven. This voltage is adjustable with the ALC ADJ. knob located above the ALC jack. Setting ALC voltage properly fed back to the transceiver, we recommend you to keep the maximum output power constant or hold the power at a certain level. Also ALC is useful in avoiding your SSB signal from being distorted when overdriven. Depending upon the manufacturer of the transceiver, the suitable ALC voltage differs. ICOM may need 0~-4V, and Yaesu may need 0~-5V range. Kenwood may need -6~-8V maximum. Check your transceiver manual.

8-1 Prepare an ALC control cable using RCA plug supplied in the package. Solder a single wire or (more preferably) a shielded single wire to the center pin of RCA plug and solder the shield braid to the outer side of the plug. Connect the control cable to the “ALC (or EXTERNAL ALC)” jack of the transceiver. External ALC input is sometimes available at one of the pins of the “ACC” socket of the transceiver as well.

8-2 At first, turn ALC ADJ full clockwise. Drive the amplifier in CW/RTTY mode to full output power. Then turn the ALC ADJ counter-clockwise. Observe the SWR/Power meter at the output, (or Pf of the multimeter). Stop turning the ALC ADJ at the point the power starts to decrease. Or if you wish to further reduce the power, keep turning ALC ADJ until the desired level is achieved. If you further try to increase the drive power you will now see the output power become rather saturated, from these adjustments.

(Maximum ALC voltage produced is -10V when the amplifier output power is over 200W.)

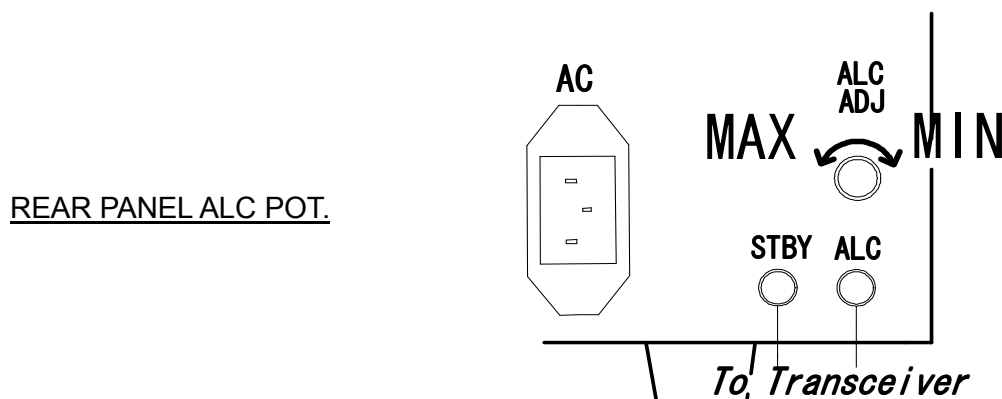

9. Protection Circuits

There are five major protection functions in this amplifier. If the amplifier has shut down for some reason, before re-setting, correct the possible cause of the shut down. Turn off the POWER once and back on to reset.

9-1 O. DRIVE (Over Drive / Band Miss-set)

When the drive power exceeds the 100W level, the amplifier will shut down to STAND-BY mode (or receive) in order to protect the input side of the power FET's. This protection might also activate if the band is set wrong. This usually occurs, when the amplifier band setting is lower than that of the transceiver.

9-2 O. HEAT (Over Heat)

When the temperature of the aluminum heat sink in the power amplifier reaches 80 degrees C, the amplifier defaults to RECEIVE mode to protect the power FET's.

9-3 O. VOLT (Over Voltage)

If there is a sudden AC line voltage spike, the FET drain voltage may rise above acceptable levels, and O. VOLT protection may trip.

9-4 FUSE (Fuse Blown)

If either of the glass fuses (15A) on PC1662V fails, "FUSE" lamp lights. Under normal usage of the amplifier, this failure should rarely (if ever) occur. If it occurs, there is a possibility that the power FET's have failed together. If the amplifier cannot be reset, consult with the dealer or the service center.

9-5 PR (Reflected Power Protection)

If reflected power from the antenna reaches approximately 80W, the PR protection may trip. If it does, one solution is to reduce the drive power from the transceiver. Or you may need to check that your antenna match (SWR) is still OK. If the match cannot be corrected and the antenna system isn't faulty, use an antenna tuner.

As noted above, the amplifier is equipped with several kinds of fast acting protection circuits using the latest in analog technology. However, if the amplifier is operated in such a manner that multiple protections work repeatedly over a long period of time, the amplifier can be seriously damaged.

10. Explanation of Major Circuits

Four major circuit blocks are explained in their basic form and using signal flows.

- 10-1 Main DC Power Supply
- 10-2 Power Amp/ L.P.F.
- 10-3 RF Power Detector/ TX-RX Switching
- 10-4 Control Board

10-1 Main DC Power Supply

The main DC power supply feeds the 42V DC power to the final PA stage. It is a state of art, switching power supply with high efficiency. A part of 42V line is converted to 24V using a DC-DC converter and is supplied to the cooling fan.

10-2 Power Amp (PA PC1662V) / L.P.F. (PC1817)

The RF PA is the heart of this amplifier and is composed of four VRF150 MOS FET's made by Microsemi of USA. The amplifier is a parallel push-pull, class AB amplifier. The gate bias supply circuit is regulated for the best stability and is thermally compensated.

The PA has a 6dB attenuator on the input for gain reduction and to enhance the stability of the wide band power PA. The heat sink has two different thermal sensors to detect temperatures of 50 deg.C, and 80 deg.C, respectively. At 50 deg.C, the cooling fan shifts into high-speed mode. At 80 deg.C, the amplifier will lock the amplifier into RECEIVE mode to protect the power FET's.

In the L.P.F. (output low pass filter) circuit, there are seven band filters that are selected by the manual band switch. Each L.P.F. is used to reject harmonics so that the amplifier meets international telecommunication equipment standards, including FCC rule.

10-3 RF Power Detector / TX-RX Switch (PC1821)

As illustrated in the block diagram, there are two RF power detectors on this board. One detects the drive signal level from the radio and the other monitors the outgoing power and the reflected power from the load (antenna).

The TX-RX switch (Send-Receive switching) will switch the flow of drive power/output power and the incoming signal from the antenna with two high-speed relays mounted at the input and output sides of the PA.

10-4 Control Board (PC1818)

This is the heart of the control signal processing for the HL-550FX. It judges the operating condition of the amplifier, as well as issuing the commands to the peripheral circuits. Various analog signals are processed such as RF drive from the transceiver, RF power signals at various points, DC power supply information, etc. There are ope-amps, various three terminal voltage regulators, GAL logic device etc. Warning signals are processed by the logic IC for Over Heat, Over Voltage, Pr, Band Miss-set etc. Ope-amps produce the necessary DC signals to drive the Pf, Pr meters. Also there is a control circuit that issues the drive shut down command in case of the over drive, band miss-set and high antenna SWR conditions.

11. Trouble Shooting

Failure	Possible Cause	Solution
AC mains not operating	<ul style="list-style-type: none"> ① AC fuses blown ② AC cord not plugged in ③ Interlock switch lifting ④ Wrong tap used on power transformer primary 	<ul style="list-style-type: none"> ① Replace with new ones. ② Plug in securely. ③ Screw bolts tightly on the top cover. ④ Correct primary wiring.
Can't enter Transmit mode	<ul style="list-style-type: none"> ① Remote control cable not connected ② Protection circuits ON 	<ul style="list-style-type: none"> ① Check the cable and connect properly. ② Check the drive power, antenna SWR. Reset with AC POWER switch.
O.Drive lights	<ul style="list-style-type: none"> ① RF overdrive ② Band miss-set 	<ul style="list-style-type: none"> ① Decrease drive. ② Match the BAND correctly.
PR lights	<ul style="list-style-type: none"> ① Reflected power high, Antenna SWR high ② Poor connection to coax cables 	<ul style="list-style-type: none"> ① Check/adjust antenna (Or decrease drive.). ② Check the coax cable connectors.
O. Volt lights	<ul style="list-style-type: none"> ① Drain voltage of power amp extremely high 	<ul style="list-style-type: none"> ① Check AC line stability.
FUSE lights	<ul style="list-style-type: none"> ② Fuse blown ③ Antenna SWR high ④ Short circuit 	<ul style="list-style-type: none"> ② Replace F202 and F203 (15A) on the PA board (PC1662V). ③ Adjust the antenna. ④ Contact the distributor, or service center.
O.Heat lights	<ul style="list-style-type: none"> ① Internal Temperature above 80 deg.C 	<p>Cool off until LED turns off. Check for air intake blockages. Also check air vent on top cover.</p>
TVI, FMI	<ul style="list-style-type: none"> ① Overdrive ② RF leakage from coax cable, grounding wire, AC power cord etc. 	<ul style="list-style-type: none"> ① Decrease the drive. Check ALC setting. ② Insert common mode filters on antenna cable or AC line. Add clamp-on ferrite cores (TDK, Amidon, Palomar) on various cables.

12. Parts Layout

- 12-1 Top View (Detailed)
- 12-2 Top View & Side View
- 12-3 PA Unit (PC1662V)
- 12-4 LPF Unit (PC1817), Sub AC Unit (PC1819)
- 12-5 Frequency Detector Unit (PCS1733), RF Power Detector Unit (PC1821)
- 12-6 Control Unit (PC1818)

13. Schematic Diagrams

- 13-1 PC1662V PA (Power Amplifier) Unit
- 13-2 PC1821 RF Power Detector Unit
- 13-3 PC1817 LPF (Low Pass Filter) Unit
- 13-4 PCS1733 Frequency Detector Unit
- 13-5 PC1818 Control Unit
- 13-6 Overall Block Diagram