



JOHN DEERE

John Deere Mighty Movers™ DUMP TRUCK

3+⁺



Adult Assembly Required: 4 x "AA" Batteries and 2 x "AAA" Alkaline Batteries Required (Not Included)
Phillips Screwdriver Required for Battery Installation (Not Included)

IMPORTANT! Children Should Not Operate This Toy Without Adult Supervision

Installing Batteries Into Vehicle

1. Turn vehicle upside down and, using a Phillips screwdriver, loosen the screw that holds the vehicle body in place.

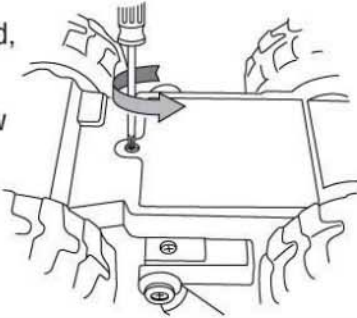

2. Remove the battery cover.

3. Install 4 fresh "AA" batteries as shown. Replace battery cover and re-tighten screw.

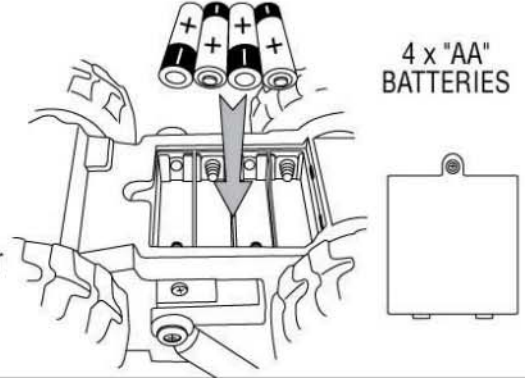

4 x "AA" BATTERIES

Installing Batteries Into Remote Controller

1. Turn remote controller upside down and, using a Phillips screwdriver, loosen the screw that holds the battery cover in place.

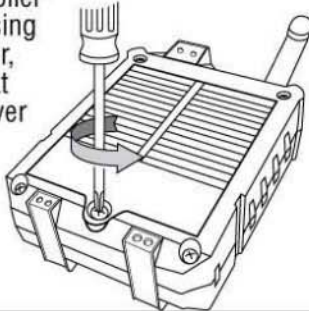

2. Install 2 fresh AAA batteries as shown. Replace battery cover and re-tighten screw.

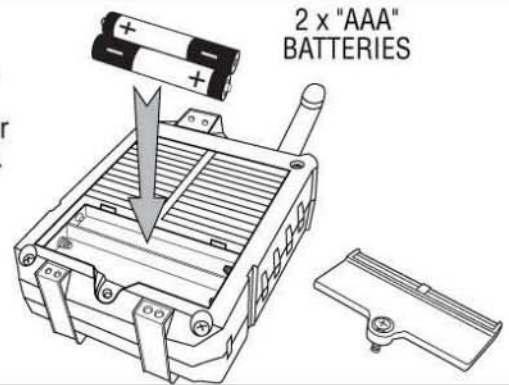

2 x "AAA" BATTERIES

Play Instructions

1. Insert and turn figure to start tractor as shown.

2. Place the vehicle on a smooth, flat surface.

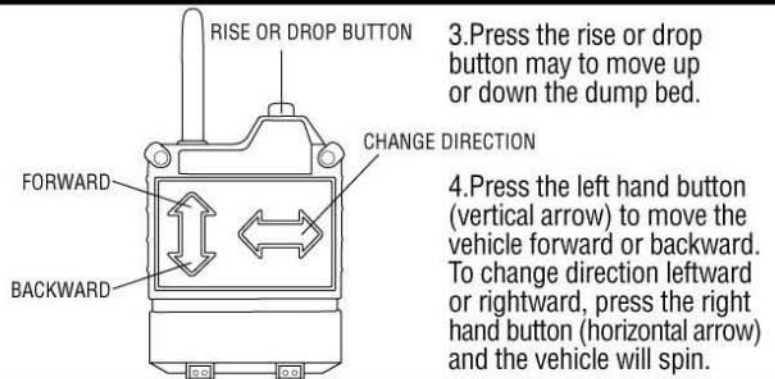

3. Press the rise or drop button may to move up or down the dump bed.

4. Press the left hand button (vertical arrow) to move the vehicle forward or backward. To change direction leftward or rightward, press the right hand button (horizontal arrow) and the vehicle will spin.

This toy is equipped with an automatic shut-off feature to conserve battery life. If it is not used for an extended period, switch the toy off and on again to reactivate.

Carrier frequency and field strength Frequency Channel: 49.860MHz Field Strength: 61.2dBuv/m @ 3m

Important Battery Information:

- * Exhausted batteries are to be removed from the toy and disposed of properly.
- * Non-rechargeable batteries are not to be recharged.
- * Only rechargeable batteries are to be charged under adult supervising.
- * Rechargeable batteries are to be removed from the item before being charged.
- * Only batteries of the same or equivalent type as recommended are to be used.
- * Different types of batteries or new and used batteries are not to be mixed.
- * Batteries are to be inserted with the correct polarity.
- * The supply terminal should not be short circuited
- * Do not mix old and new batteries

WARNING:

Changes or modifications to this unit not expressly approved by the party responsible for compliance could void the user's authority to operate the equipment.

CAUTION:

Remove all plastic fasteners before giving to child. Product and colors may vary. Pls keep the packaging due to contain important information.

NOTE: This equipment has been tested and found to comply with the limits for a Class B digital device, pursuant to Part 15 of the FCC Rules. These limits are designed to provide reasonable protection against harmful interference in a residential installation. This equipment generates, uses and can radiate radio frequency energy and, if not installed and used in accordance with the instructions, may cause harmful interference to radio communications.

However, there is no guarantee that interference will not occur in a particular installation. If this equipment does cause harmful interference to radio or television reception, which can be determined by turning the equipment off and on, the user is encouraged to try to correct the interference by one or more of the following measures:

- Reorient or relocate the receiving antenna.
- Increase the separation between the equipment and receiver.
- Connect the equipment into an outlet on a circuit different from that to which the receiver is connected.
- Consult the dealer or an experienced radio/TV technician for help.

This radiocommunication device complies with all the requirements of Industry Canada Standard RSS-310. "Operation is subject to the following two conditions: (1) this device may not cause interference, and (2) this device must accept any interference, including interference that may cause undesired operation of the device."

"Ce dispositif de radiocommunication rencontre toutes les exigences de la norme CNR-310 d'Industrie Canada." L'utilisation de ce dispositif est autorisée seulement aux deux conditions suivantes: (1) il ne doit pas produire de brouillage, et (2) l'utilisateur du dispositif doit être prêt à accepter tout brouillage radioélectrique reçu, même si ce brouillage est susceptible de compromettre le fonctionnement du dispositif.



For questions or comments call Learning Curve customer service at 1-800-704-8697 or email: rcs@learningcurve.com

Made in China 099-52523A