

Introduction

The GRX1 receiver is a multi-frequency, GPS+ receiver built to be the most advanced and compact receiver for the surveying market. The receiver is a multi-function, multi-purpose receiver intended for precision markets.

Precision markets means markets for equipment, subsystems, components and software for surveying, construction, commercial mapping, civil engineering, precision agriculture and land-based construction and agriculture machine control, photogrammetry mapping, hydrographic and any use reasonably related to the foregoing.

The GRX1 can receive and processes multiple signal types (including the latest GPS L1, L2, C/A, L2C GLONASS L1, L2, C/A signals) improving the accuracy and reliability of the survey points and positions, especially under difficult jobsite conditions. The multifrequency and GPS+ features of the receiver combine to provide a positioning system accurate for any survey. Several other features, including multipath mitigation, provide under-canopy and low signal strength reception. The receiver provides the functionality, accuracy, availability, and integrity needed for fast and easy data collection.

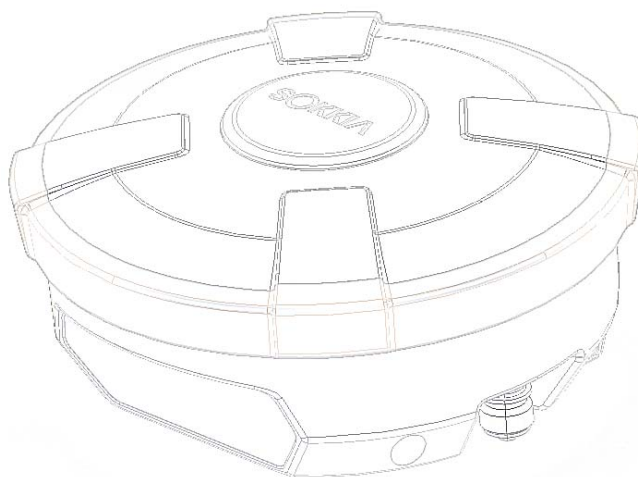

Figure 1-1. GRX1 Receiver

Principles of Operation

Surveying with the right GPS receiver can provide users accurate and precise positioning, a requirement for any surveying project. This section gives an overview of existing and proposed Global Navigation Satellite Systems (GNSS) and receiver functions so that basic operating principles can be applied.

GNSS Overview

Currently, the following two global navigation satellite systems (GNSS) offer line-of-site radio navigation and positioning, velocity, and time services on a global, all-weather scale to any user equipped with a GNSS tracking receiver on or near the Earth's surface:

- GPS - the Global Positioning System maintained and operated by the United States Department of Defense. For information on the status of this system, visit the US Naval Observatory website (<http://tycho.usno.navy.mil/>) or the US Coast Guard website (<http://www.navcen.uscg.gov/>).
- GLONASS - the Global Navigation Satellite System maintained and operated by the Russian Federation Ministry of Defense. For information on the status of this system, visit the Coordinational Scientific Information Center website (<http://www.glonass-ianc.rsa.ru/>).

Despite numerous technical differences in the implementation of these systems, satellite positioning systems have three essential components:

- Space - GPS and GLONASS satellites orbit approximately 12,000 nautical miles above Earth and are equipped with a clock and radio. These satellites broadcast ranging signals and various digital information (ephemerides, almanacs, time and frequency corrections, and so forth).
- Control - Ground stations located around the Earth that monitor the satellites and upload data, including clock corrections and new ephemerides (satellite positions as a function of time), to ensure the satellites transmit data properly.
- User - The community and military that use GNSS receivers to calculate positions.

Calculating Absolute Positions

When calculating an absolute position, a stationary or moving receiver determines its three-dimensional position with respect to the origin of an Earth-Center Earth-Fixed coordinate system. To calculate this position, the receiver measures the distance (called pseudo-ranges) between it and at least four satellites.

The measured pseudo-ranges are corrected for clock differences (receiver and satellites) and signal propagation delays due to atmospheric effects. The positions of the satellites are computed from the ephemeris data transmitted to the receiver in navigation messages. When using a single satellite system, the minimum number of satellites needed to compute a position is four. In a mixed satellite scenario (GPS, GLONASS), the receiver must lock onto five or more satellites to account for the different time scales used in these systems and to obtain an absolute position.

Calculating Differential Positions

DGPS, or Differential GPS, is a relative positioning technique where the measurements from two or more remote receivers are combined and processed using sophisticated algorithms to calculate the receivers' relative coordinates with high accuracy. DGPS accommodates various implementation techniques that can be classified according to the following criteria:

- The type of GNSS measurements used, either code-phase differential measurements or carrier-phase differential measurements
- If real-time or post-mission results required. Real-time applications can be further divided according to the source of differential data and communication link used.

With DGPS in its most traditional approach, one receiver is placed at a known, surveyed location and is referred to as the reference receiver or base station. Another receiver is placed at an unknown location and is referred to as the remote receiver or rover. The reference station collects the code-phase and carrier-phase measurements from each GNSS satellite in view.

- For real-time applications, these measurements and the reference station coordinates are then built up to the industry standard RTCM - or various proprietary standards established for transmitting differential data - and broadcast to the remote receiver (s) using a data communication link. The remote receiver applies the transmitted measurement information to its observed measurements of the same satellites.
- For post-mission applications, the simultaneous measurements from reference and rover stations are normally re-corded to the receiver's internal memory (not sent over communication link). Later, the data are downloaded to computer, combined, and processed. Using this technique, the spatially correlated errors - such as satellite orbital errors, ionospheric errors, and tropospheric errors - can be significantly reduced, thus improving the position solution accuracy.

A number of differential positioning implementations exist, including post-processing surveying, real-time kinematic surveying, maritime radio beacons, geostationary satellites (as with the OmniSTAR service), and satellite based augmentation systems (WAAS, EGNOS, MSAS).

The real-time kinematic (RTK) method is the most precise method of real-time surveying. RTK requires at least two receivers collecting navigation data and communication data link between the receivers. One of the receivers is usually at a known location (Base) and the other is at an unknown location (Rover). The Base receiver collects carrier phase measurements, generates RTK corrections, and sends this data to the Rover receiver. The Rover processes this transmitted data with its own carrier phase observations to compute its relative position with high accuracy, achieving an RTK accuracy of up to 1.0 cm horizontal and 2.0 cm vertical.

Essential Components for Quality Surveying

Achieving quality position results requires the following elements:

- Accuracy - The accuracy of a position primarily depends upon the satellite geometry (Geometric Dilution of Precision, or GDOP) and the measurement (ranging) errors.
 - Differential positioning (DGPS and RTK) strongly mitigates atmospheric and orbital errors, and counteracts Selective Availability (SA) signals the US Department of Defense transmits with GPS signals.
 - The more satellites in view, the stronger the signal, the lower the DOP number, the higher positioning accuracy.
- Availability - The availability of satellites affects the calculation of valid positions. The more visible satellites available, the more valid and accurate the position. Natural and man-made objects can block, interrupt, and distort signals, lowering the number of available satellites and adversely affecting signal reception.
- Integrity - Fault tolerance allows a position to have greater integrity, increasing accuracy. Several factors combine to provide fault tolerance, including:
 - Receiver Autonomous Integrity Monitoring (RAIM) detects faulty GNSS satellites and removes them from the position calculation.
 - Five or more visible satellites for only GPS or only GLONASS; six or more satellites for mixed scenario
 - Satellite Based Augmentation Systems (WAAS, EGNOS, and so on) creates and transmit, along with DGPS corrections, data integrity information (for example, satellite health warnings).
 - Current ephemerides and almanacs.

Conclusion

This overview simply outlines the basics of satellite positioning. For more detailed information, visit the [Sokkia Topcon](#) website.

Receiver Overview

When power is turned on and the receiver self-test completes, the receiver's 72 channels initialize and begin tracking visible satellites. Each of the receiver's channels can be used to track any one of the GPS or GALILEO signals. The number of channels available allows the receiver to track all visible global positioning satellites at any time and location.

An internal GPS+ antenna equipped with a low noise amplifier (LNA) and the receiver's radio frequency (RF) device are connected with a co-axial cable. The wide-band signal received is down-converted, filtered, digitized, and assigned to different channels. The receiver processor controls the process of signal tracking.

Once the signal is locked in the channel, it is demodulated and necessary signal parameters (carrier and code phases) are measured. Also, broadcast navigation data are retrieved from the navigation frame.

After the receiver locks on to four or more satellites, its absolute position in WGS-84 and the time offset between the receiver clock and GPS time are computed. This information and the measurement data can be stored in the optional SD card and downloaded later onto a computer, then processed using a post-processing software package. When the receiver operates in RTK mode, raw data measurements can also be recorded into the receiver's internal memory. This allows the operator to double check real-time results obtained in the field.

Depending on your options, capabilities of the receiver include:

- Satellite based augmentation systems (WAAS, EGNOS, and so forth).
- Adjustable phase locked loop (PLL) and delay lock loop (DLL) parameters
- Dual- or multi-frequency modes, including static, kinematic, real-time kinematic (RTK), and differential GPS (DGPS) survey modes (DGPS modes include static, kinematic, and RTK)
- Auto data logging
- Setting different mask angles
- Setting different survey parameters
- Static or dynamic modes

Getting Acquainted

The GRX1 is a 72-channel GPS receiver, which includes the following:

- External, detachable batteries
- One data ports
- Interface for controlling and viewing data logging
- External memory card slot
- Internal radio modem
- Bluetooth wireless technology module
- Optional GSM/GPRS module
- Optional CDMA module (only with the Digital UHF radio modem)

Batteries

The GRX1 receiver comes equipped with one detachable, re-chargeable batteries (Figure 1-2) for powering the receiver.

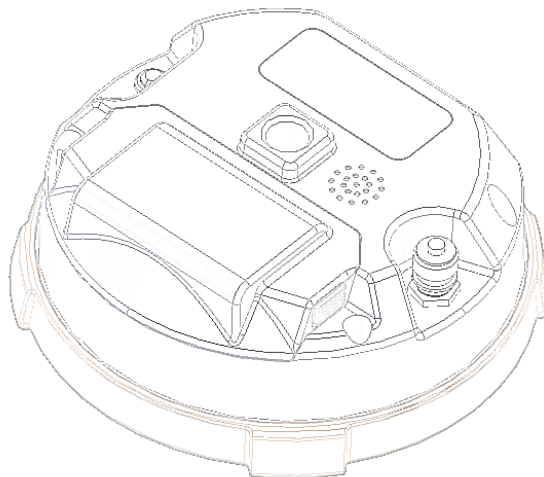

Figure 1-2. GRX1 Batteries

Please use CDC68 as battery charging cradle.

It takes approximately four **hours** to completely charge one battery, and **eight** hours to charge two batteries. (In BDC58 use)

GRX1 Receiver

The GRX1 receiver's advanced design reduces the number of cables required for operation, allowing for more reliable and efficient surveying. The casing allocates space for one removable, rechargeable batteries, SD and SIM card slots, a Bluetooth wireless technology module and a radio modem communications board.

The GRX1 comes in one of the following configurations:

- with an FH915 Plus TX/RX/RP radio modem and a GSM/GPRS module
- with a 1W Digital UHF TX/RX radio modem, depending on the country
- with a Digital UHF radio modem and a GSM/GPRS module
- with a Digital UHF TX/RX radio modem and a CDMA module

Other features include one data ports, a power port, and a MINTER for viewing status and controlling data input/output.

MINTER

The MINTER is the receiver's minimum interface used to display and control data input and

output (Figure 1-5).

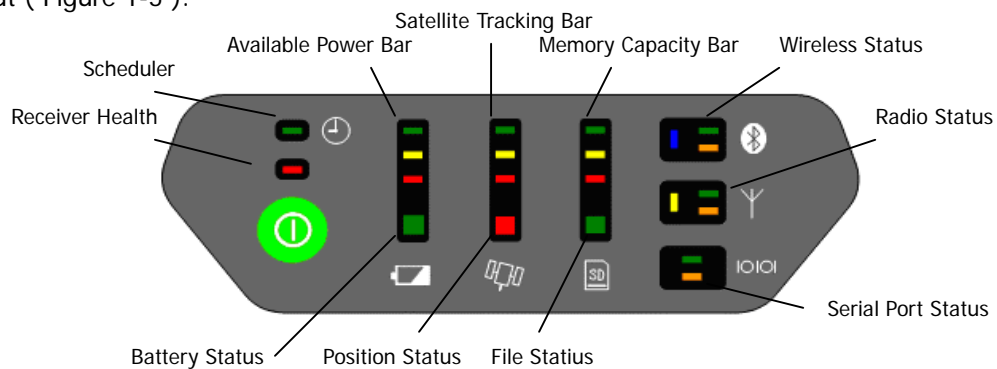

Figure 1-5. GRX1 MINTER

Available Power Bar indicates battery remaining or voltage.

- Green - indicate greater than 50%.
- Yellow - indicate greater than 25%.
- Red - indicate greater than 10%.
- Red blink - indicate less than 10%.

Battery Status LEDs indicates an available battery and the usage condition.

- Green - only battery is available.
- Red - only external power is available.
- Umber - battery and external power are available.

Satellite Tracking Bar indicate number of satellites tracked.

- Green - indicate greater than 8 satellites.
- Yellow - indicate 6 or 7 satellites.
- Red - indicate 4 or 5 satellites.
- Red blink - indicate 3, 2, 1 or 0 satellites.

Position Status LEDs indicate current type position computed.

- Green - Integer RTK or Fixed RTK.
- Umber - DGPS or Float RTK.
- Red - Single

Memory Capacity Bar indicate a percentage of available space in the memory.

- Green - indicate greater than 50%.
- Yellow - indicate greater than 25%.
- Red - indicate greater than 10%.
- Red blink - indicate greater than 0%.

File Status LEDs indicate status of current file.

- Green - file is opened.
- Umber blink - writing are done on the file.
- (light out) - file is not opened or there is no memory card in slot.

Wireless Status LEDs indicate status of the internal Blue-tooth module.

- Blue - internal Bluetooth connection has been established.
- Blue blink - internal Bluetooth connection has not been made, as long as the module has power.
- Blue dark - internal Bluetooth is not being powered.
- Green flash - data is transmitted from the Bluetooth port.
- Orange flash - data is received from the Bluetooth port.

Radio Status LEDs indicate status of the internal UHF radio and GSM module.

- Yellow - internal radio is being powered.
- Yellow dark - internal radio is not being powered.
- Green flash - data is transmitted from the internal radio port.
- Orange flash - data is received from the internal radio port.

Serial Port Status LEDs indicates status of the serial port.

- Green flash - data is transmitted from the serial port.
- Orange flash - data is received from the serial port.

The power button turns the receiver on, off and receiver setting.

The power button is used to turn the unit on or off, format or erase the internal memory, or perform a factory reset. The number of seconds that you press the power button determines how the receiver will behave. At each time interval, the receiver issues voice messages or sounds to guide you through the process.

| Action | Number of seconds | Description |
|----------|-------------------|---|
| Turn on | 1 | Press the button for 1 second and release to turn on the receiver. The battery life gauge indicates the progress of the startup sequence. After startup (approximately 20 seconds), the battery life gauge indicators will turn off for a short period, and you will hear the "Receiver Ready" message or sound that indicates that the system is operational. Note: It is normal for the receiver health indicator LEDs to illuminate during startup. |
| Turn off | 3 | Press the button for 3 seconds and/or until you hear the "Power Off" message or sound, and the top three battery life gauge LEDs illuminate. |

| | | |
|---------------|----|---|
| Factory reset | 10 | <p>With the receiver on, press the button for 10 seconds until you hear the "Factory Reset" message or sound and the top three LEDs on the battery life, satellite tracking, and memory gauges illuminate.</p> <p>Release the button to reset all stored parameters on the receiver to their default values.</p> <p>Note: This action is irreversible.</p> |
| Erase memory | 20 | <p>With the receiver on, press the button for 20 seconds until you hear the "Delete Files" message or sound and the top three LEDs on the memory gauge illuminate.</p> <p>Release the button to delete all the files from the memory.</p> <p>Note: This action is irreversible.</p> <p>If you are unsure about whether you want to delete all the files, hold the button longer than 25 seconds, so that the receiver simply returns to normal operation.</p> <p>To delete individual files from the memory, use a data collector or SOKKIA TOPCON software on your PC.</p> |
| Disregard | 25 | <p>When you hold the button longer than 25 seconds and you hear the "Continue Operation" message or sound, no action will be taken, and the receiver will return to normal operation.</p> <p>The receiver will not turn off, the data files will not be erased, and the settings will not revert to factory settings.</p> |

Data and Power Ports

The GRX1 has the following three ports (Figure 1-6):

- Serial - rimmed in **blue**; used for communication between the receiver and an external device. The body of the connector on the corresponding cable is **blue**.
- Power - rimmed in **red**; used to connect the receiver to an external power source. The body of the connector on the corresponding cable is **red**.



Figure 1-6. GRX1 Ports

External Radio Antenna Connector

The UHF and SS antennas connect to the external antenna connector under the GRX1 housing (Figure 1-7). Both modem antenna types include support for a GSM modem.

The modem antenna depends on the type of modem in-stalled in the receiver:

- UHF: Uses a BNC RF connection and comes in three versions: 410-440MHz (p/n 30-070003-01) and 440-470MHz (p/n 30-050503-01).
- Spread Spectrum: Uses a reverse polarity TNC RF connection and comes in one version: (p/n 30-030012-01).



Figure 1-7. Modem Antennas

Connector

The bottom connector (Figure 1-8) connects the receiver to either a standard 5/8"thread pole/adaptor or the quick disconnect (see "The quick disconnect adapter" on page 1-22 for details).

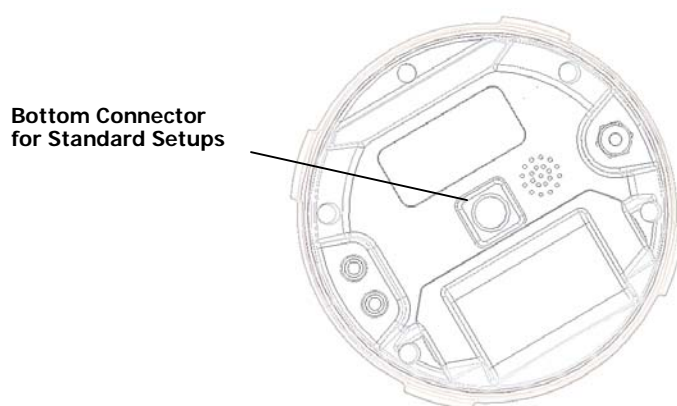

Figure 1-8. GRX1 Quick Connector

SD/MMC and SIM Card Slots

The SD and SIM card slots reside under the batteries near the base of the dome.

The SD card slot is located to the left of the MINTER inside the battery pocket (Figure 1-9) and connects an optional SD card to the receiver board to provide memory. Once installed, the SD card usually remains inside the receiver. The data that resides on the SD card can be accessed via the serial port, or Bluetooth wireless technology. A secure digital card can be purchased at a local computer supply store.

The SIM card slot is located to the inside the battery pocket and allows a standard SIM card to be installed in the receiver. Once installed, the SIM card provides a unique identification for the receiver's GSM module and enables the receiver's GSM functionality based on the subscribed services (the receiver board accesses the GSM module which accesses the SIM card). The SIM card usually remains inside the receiver. The GSM module with the SIM card installed can be accessed via **Modem-TPS** for configuration purposes. A SIM card can be purchased from a local cellular provider.

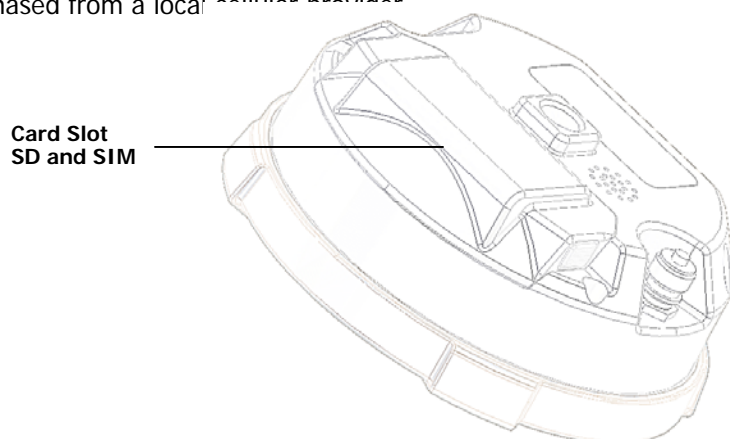
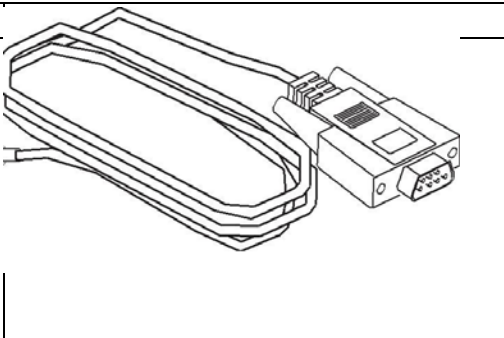

Figure 1-9. GRX1 Card Slot Example

Cables

The GRX1 package includes standard communication cables for configuring the receiver. Table 1-3 lists the cables included in the GRX1 package.

Table 1 -3. GRX1 Package Cables

| Cable Description | |
|--|--|
| <p>Serial Cable Connects the receiver to an external device (controller or computer) data transfer and receiver configuration. Body of connector back. p/n xx-xxxxxx-xx</p> |  |

Other Accessories

- **Battery** (BDC58) Li-ion Battery [4300mAh,7.2V DC].
- **Power system - without Power Cable** (CDC68) Battery BDC58 [about 150min] × 2、AC100V [without AC power cable、CDC68-11 include]
- **Power Cable** (EDC113/A/B/C/D/E) CDC68 to AC consent. It is chosen by every country.
- **Quick release** (086-0-0001)
- **Measuring Tape** (405-0-0013) 3.7m HI (Calibrated)
- **SD Card** FAT16、2GB industrial
- **CD-ROM** include Manual PDF and Config Tool
- **Carrying Case**

For more details on the accessories and package options available for the GRX1, contact the local Sokkia Topcon dealer.

Optional Accessories

Sokkia Topcon offers a wide variety of accessories especially designed to extend job reliability and efficiency. For more details on the optional accessories available for GRX1, contact the local Sokkia Topcon dealer.

- **Interface Cable** (*****) For SHC250/SHC2500, Cross connection, D-sub 9pin
- **Interface Cable** (*****) For Computer, Cross connection, D-sub9pin
- **Tribrach and Tribrach adapter** (WOA)
- **Tribrach** (WA100A) w/Optical Plummet
- **Tribrach adapter** (555501)
- **Tribrach adapter, Rotating Center** (501-0-0011)
- **Tribrach adapter** (51861) Model S2
- **Tripod** (PWF1)
- **Tripod** (30-050505-01) 2m Fixed Height Tripod
- **AC Adaptor** (EDC117)
- **Interface Cable** (BDC118)
- **External Battery Box** (*****) Output DC5V, 7.2V, 12V
- **Power Cable** (*****)
- **Bibod** (GP-SP) RTK-GPS, Steel
- **RTK-GPS Pole** (GP-SP1) RTK-GPS, 2m, connection, steel
- **Slide Pole** (AP61) 2m, Caing Case
- **2M Pole** (22-050908-01) 2m pole Fixed Hieght
- **Pole Stand** (AP71) with plastic case
- **Range Pole Level** (AP61L2) with reflective mirror, bubble tube detection range 10'
- **Controller Pole Cramp** (700264901) SECO Co., Product
- **Controller** (SHC250) with Battery, Power System, Cable
- **Controller** (SHC2500)

Option Authorization File (OAF)

Sokkia Topcon issues an Option Authorization File (OAF) to enable the specific options that customers purchase. An Option Authorization File allows customers to customize and configure the receiver according to particular needs, thus only purchasing those options needed.

Typically, all receivers ship with a temporary OAF that allows it to be used for a predetermined period of time. When the receiver is purchased, a new OAF permanently activates purchased options. Receiver options remain intact when clearing the NVRAM or resetting the receiver.

The OAF enables the following kinds of functions. For a complete list of available options and details, visit the Sokkia Topcon website or consult a Sokkia Topcon dealer.

- Type of signal (standard L1; optional L2, L5 GPS, GLONASS)
- Update rate standard 1Hz (optional 5, 10, or 20Hz)
- RTK at 1Hz, 5Hz, 10Hz, and 20Hz
- RTCM/CMRInput/Output
- Advanced multipath reduction
- Wide Area Augmentation System (WAAS)
- Receiver Autonomous Integrity Monitoring (RAIM)