



Commercial Products

Troubleshooting Guide
Groundsmaster®
345/325-D

INDEX

1. Product Overview GM 325-D/GM 345
2. Ford VSG-411 Gas Engine (GM 345)
3. Mitsubishi K3D Diesel Engine (GM 325-D)
4. Hydraulic Systems
Hydrostatic Drive Systems
5. Electrical Systems
6. Cutting Unit Drive
7. Cutting Units

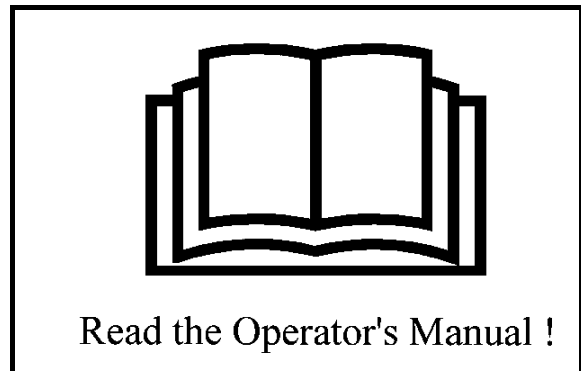

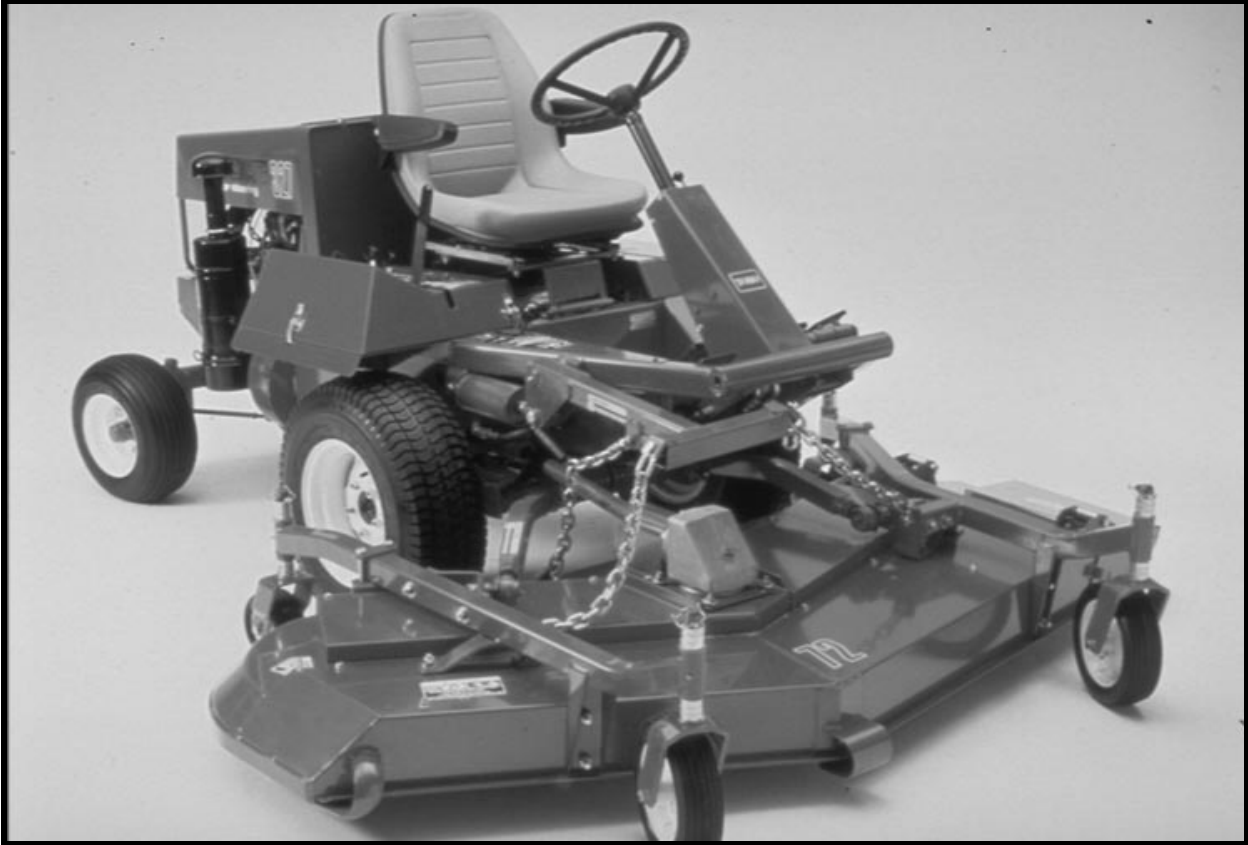

	SERIAL NUMBER
	12345 G-15-TC
	MODEL NUMBER
	VSG-411-6005-E
S.O./OPTIONS	MODEL CODE
1425	

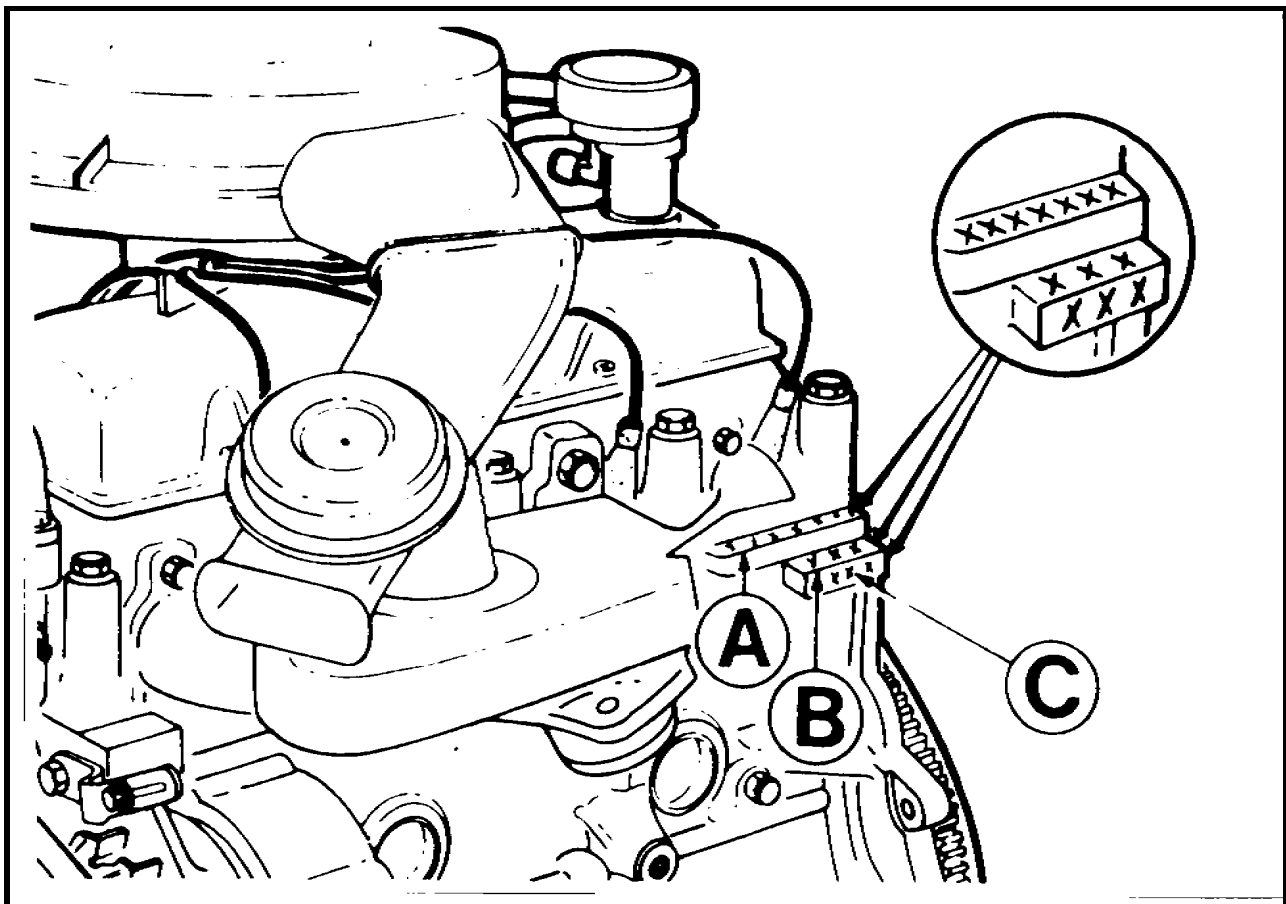

In this section we will look at some troubleshooting procedures for the Ford Gas Engine.

Engine Identification

The engine is identified with a decal affixed to the left side of the valve cover.
The decal contains the engine serial number.
The model number and displacement. (i.e. 411 = 4 cyl 1.1 liter)
The special options (S.O.) number.

The engine is also stamped on the left rear top edge of the block.
This stamping includes:

- A - Serial number.
- B - Engine Code.
- C - Engine build code: (Example 4K26)
 - The first number indicates the year.
 - The letter indicates the month in alphabetical sequence. (A January, B February, etc.)
 - The last two numbers are the day of the month.

Complaint: Low engine power

Affect:

1. Poor cutting unit performance.
2. Poor hill climbing ability.
3. Slow hydraulic response.
4. Slow throttle response.
5. Rough running engine.

Cause:

- | | |
|------------------------------------|--------------------------------------|
| 1. Incorrect engine idle settings. | 5. Cracked or bad spark plugs. |
| 2. Misadjusted carburetor linkage. | 6. Cracked or broken plug wires. |
| 3. Governor adjustments. | 7. Plugged or restricted air filter. |
| 4. Internal engine problem. | 8. Spoiled Fuel. |

Notes

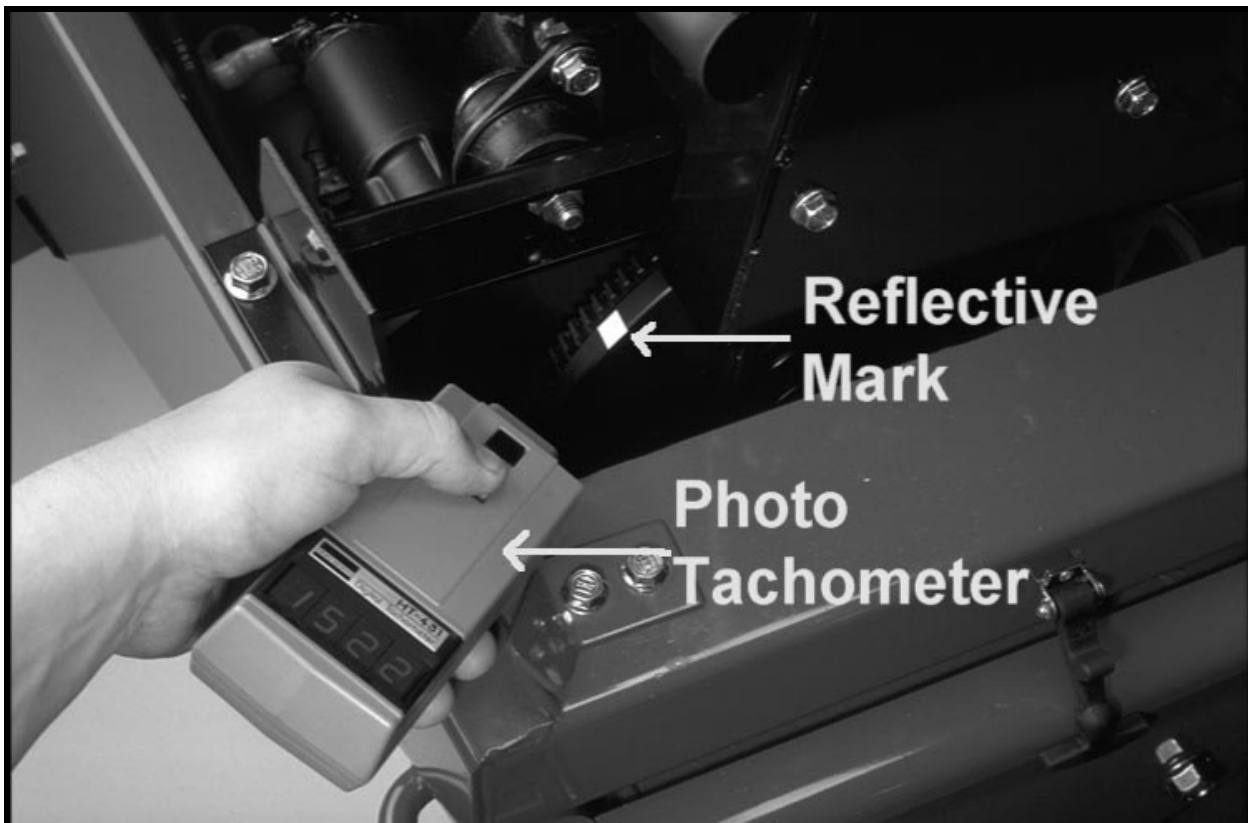

Troubleshooting:

High and Low Idle Checks.

The idle settings are important for the proper operation and long life of the machine.

Affects of incorrect idle speeds:

1. High idle too slow:
 - Low power. (engine not running at full speed)
 - Slow transport speed. (hydrostatic transmission input shaft speed too slow)
 - Poor Quality of cut. (Blade RPM and tip speed too slow)
2. High idle too fast:
 - Internal engine damage. (Excessive engine RPM can damage crankshaft and bearings)
 - Hydrostatic transmission damage. (insufficient lubrication for high input shaft speeds)
 - Engine overheating.
3. Low idle too slow:
 - Hydrostatic transmission damage.(lack of lubrication)

Checking Idle Speeds

1. Run the engine until it reaches normal operating temperature.
2. Move the throttle lever to the low idle position.
 - Low idle should be 1500 ± 100 .
3. Open the throttle to the high idle position.
 - High idle should be 3200 ± 100 .

NOTE: If high or low idle is incorrect, refer to the Operators manual for correct adjustment procedures.

Notes

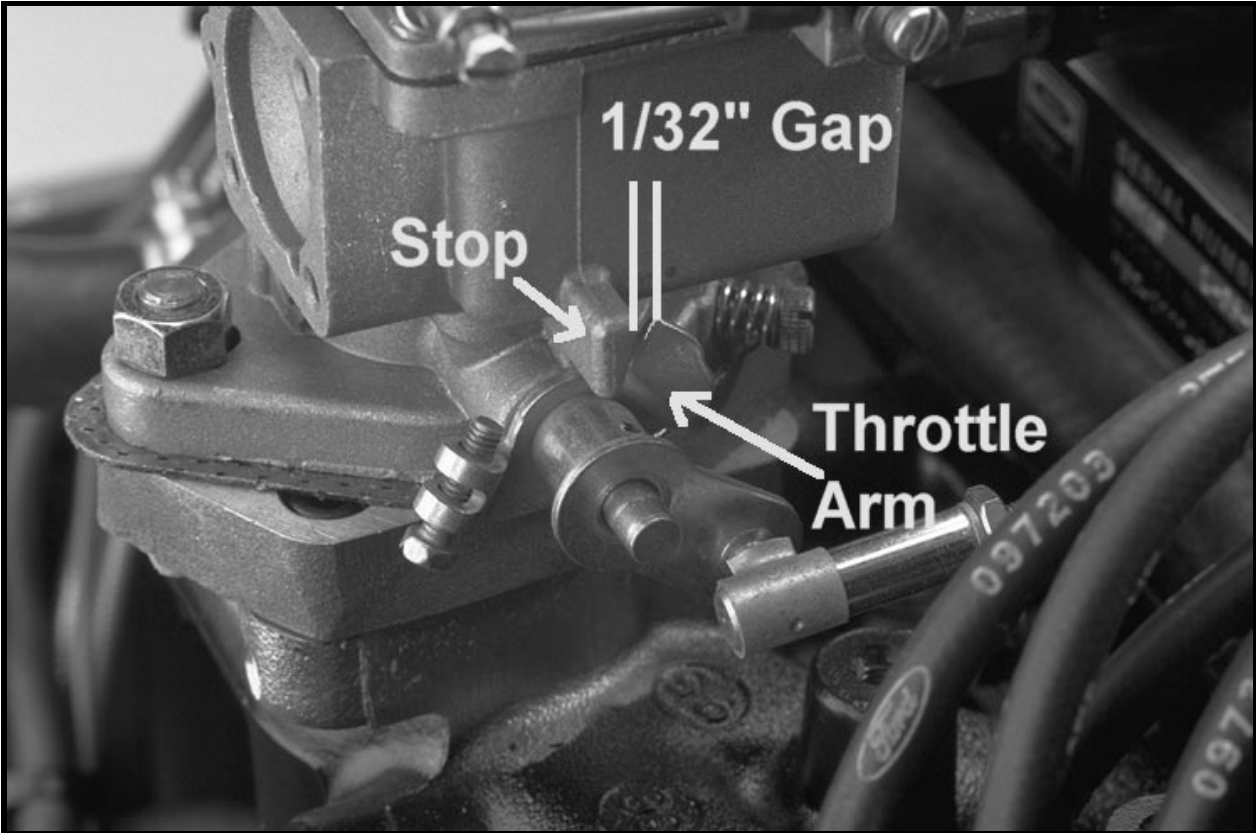

Correction:

Carburetor linkage adjustment.

1. With the engine shut off, move the throttle control to the FAST position.
2. Check the gap between the throttle arm and the stop on the carburetor base. The correct gap is 1/32" (0.78mm).
3. If the gap is not correct adjust the throttle rod by turning the ball joint until the proper gap is attained.

This adjustment insures that the carburetor throttle plate can fully open under a load, but the linkage will not bottom out against the stop.

Notes

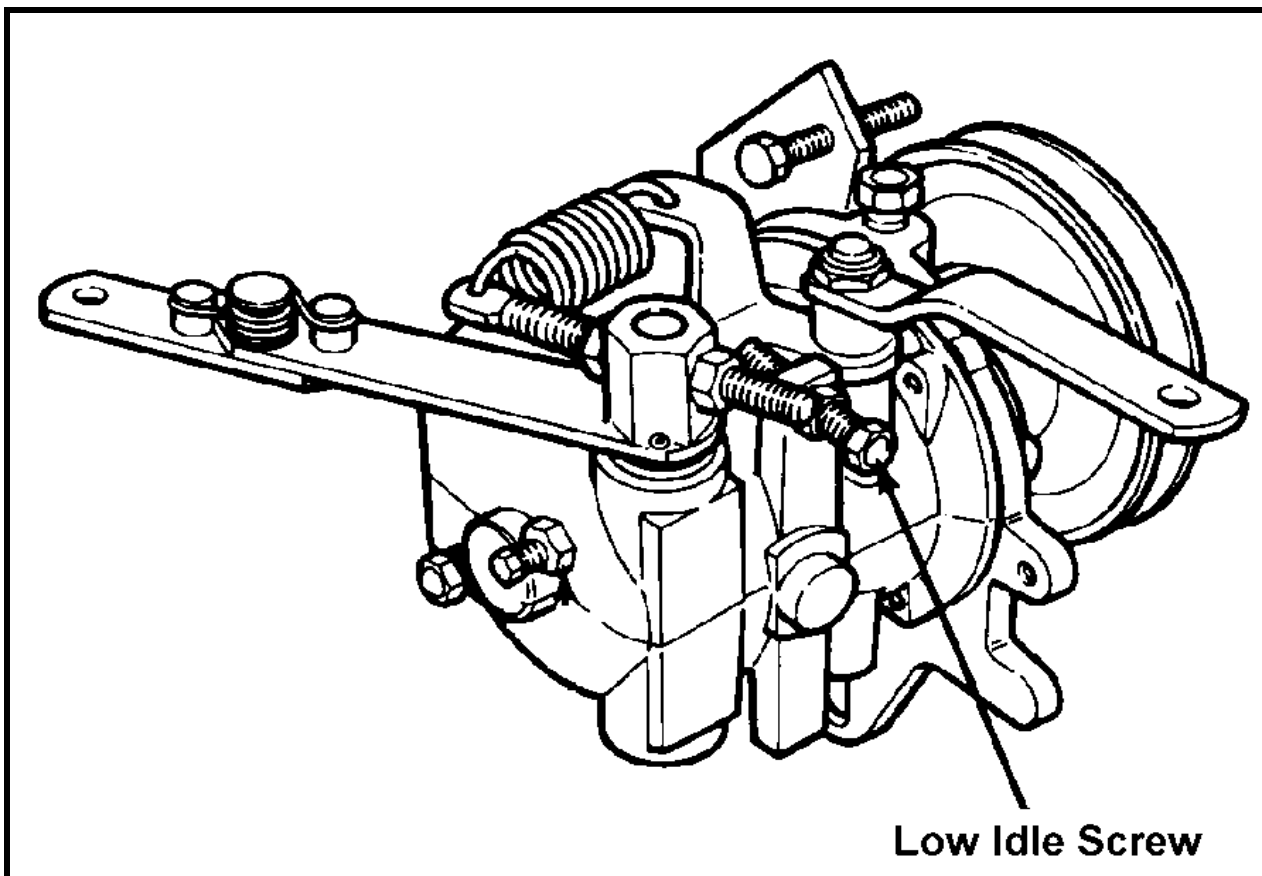
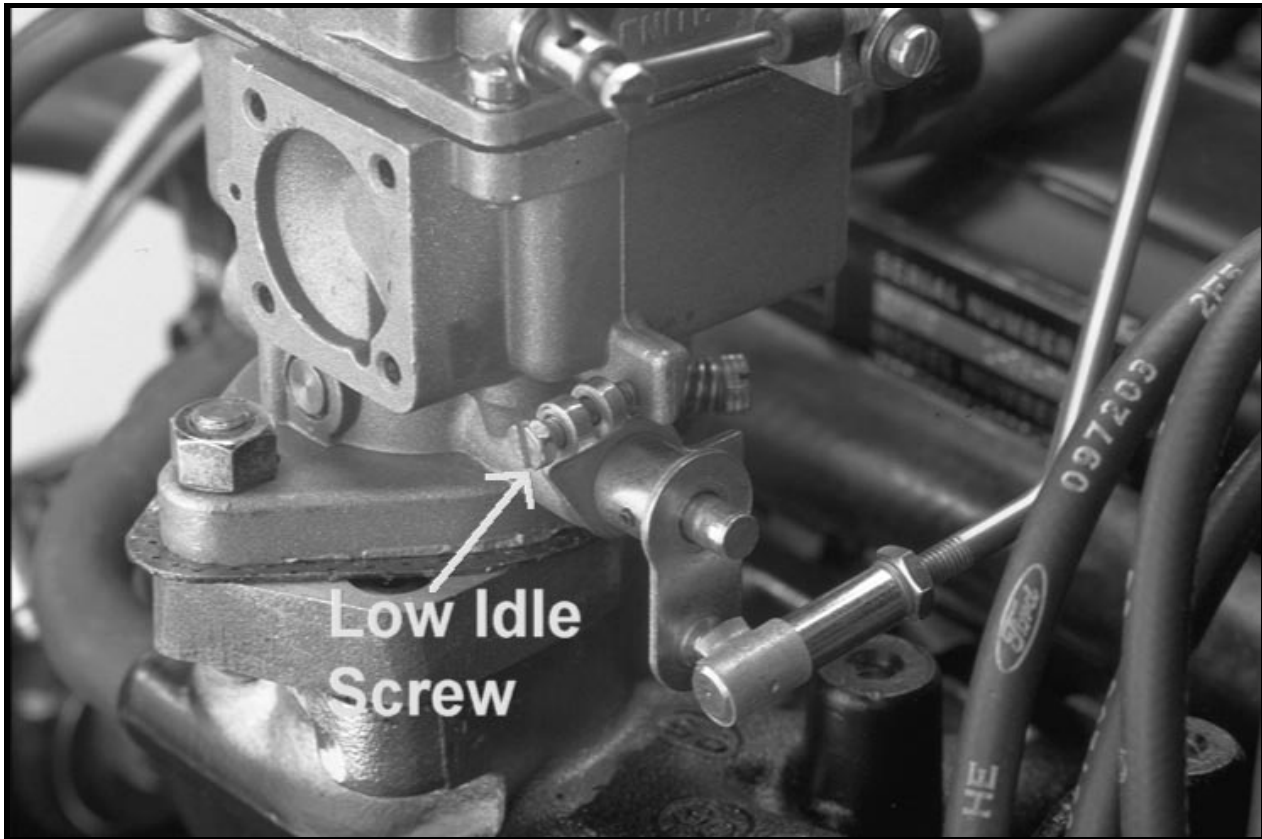

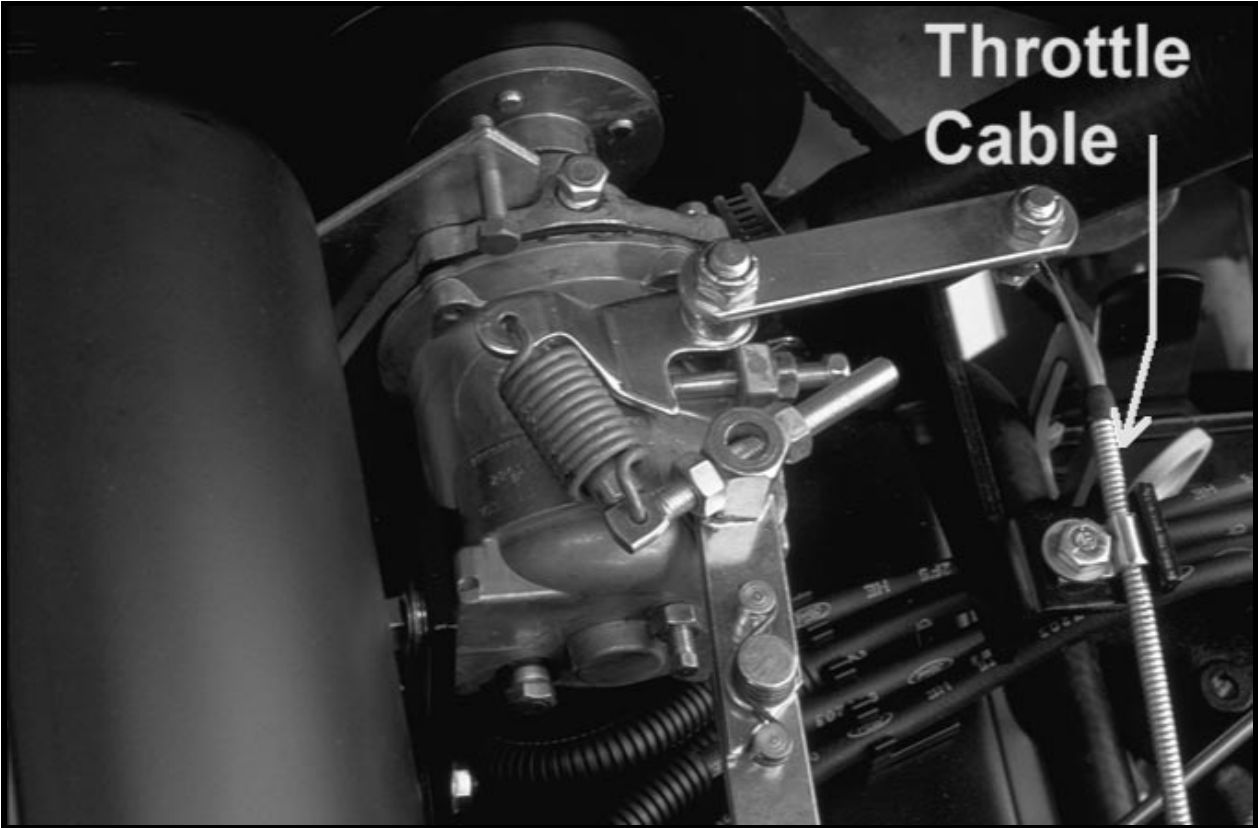
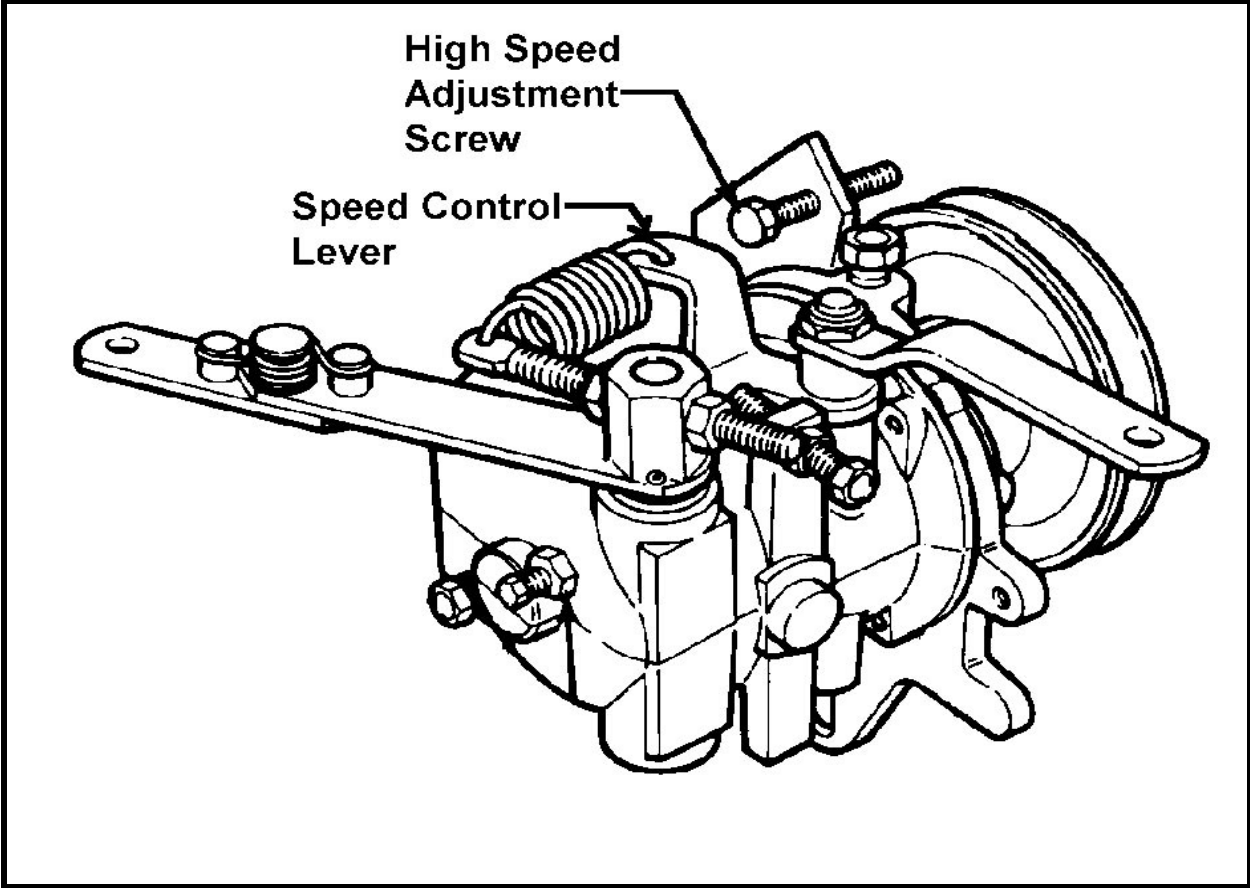

High Idle Adjustment.

1. Slowly move the throttle to the FAST position until the engine reaches 3200 ± 100 . Shut off the engine. Adjust the high speed adjustment screw until it contacts the speed control lever.

IMPORTANT: Do not overspeed the engine because transmission damaged could occur.

2. If 3200 rpm can not be attained, check the throttle cable adjustment.
 - The governor arm must not contact the cable cover when the unit is at high idle.
 - If the governor arm contacts the cable, loosen the retaining bolt and move the cable.
3. If the throttle lever on the instrument panel will not stay in the fast position, remove the panel cover and tighten the nut and capscrew at the base of the throttle lever.

Notes

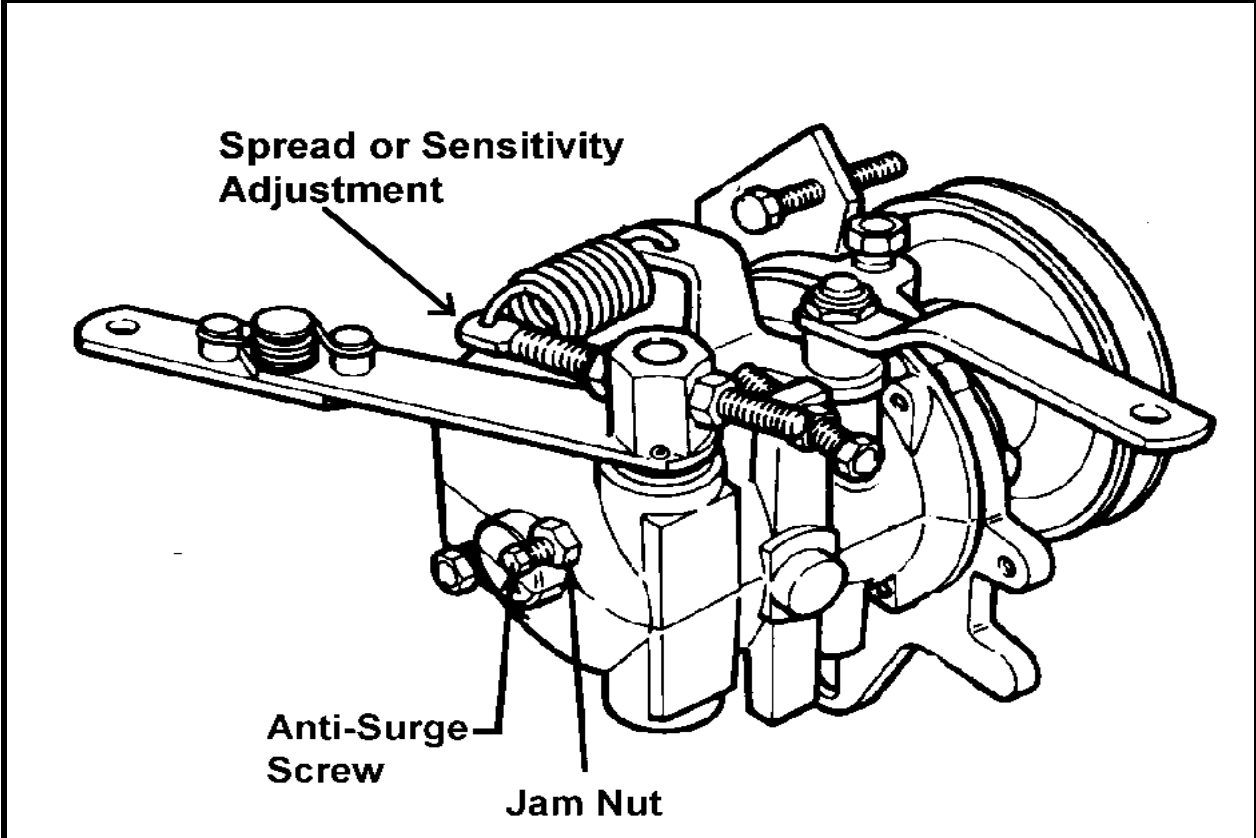
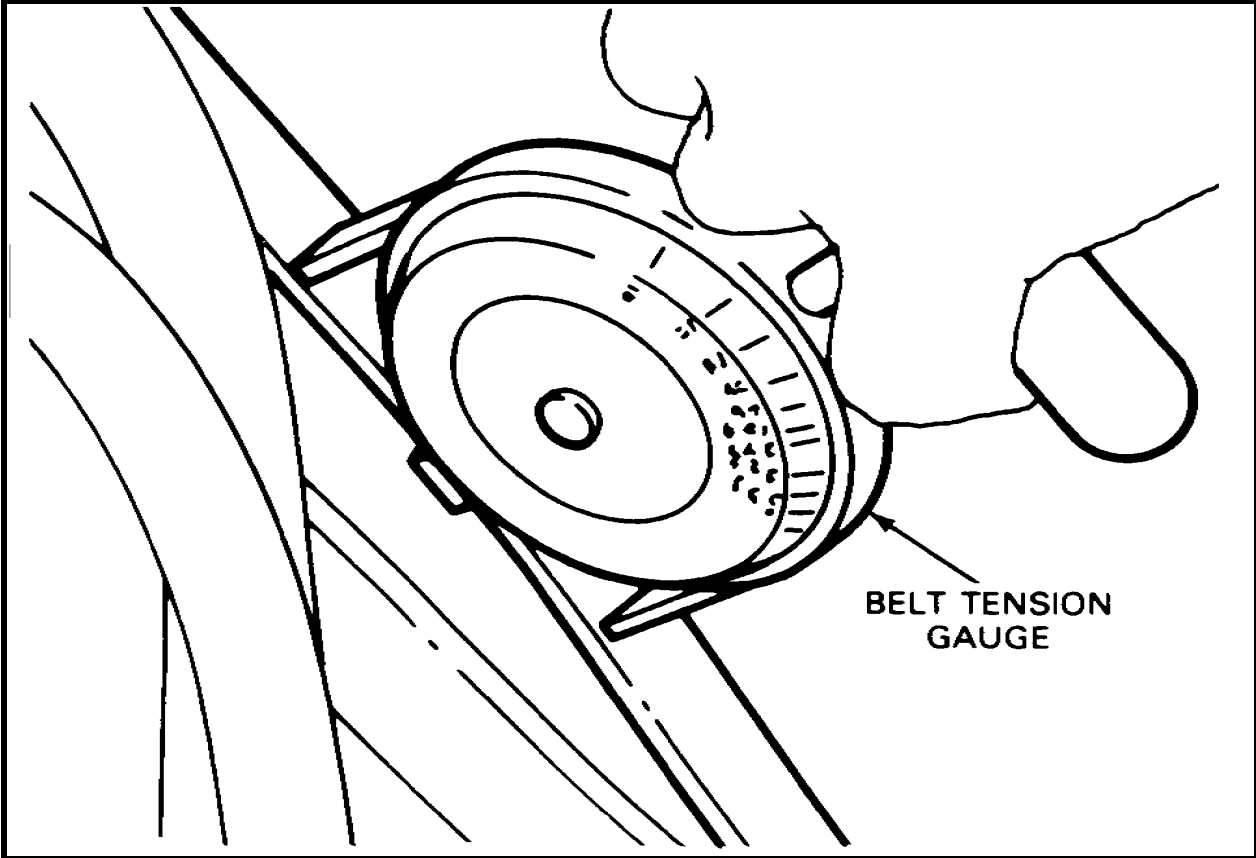

Anti-Surge Adjustment.

1. Move the throttle rapidly from SLOW to FAST. The engine should not surge, if the engine surges proceed to step 2.
2. Check the V-belts from the engine to the governor pulley and assure that they are tight.
 - The belt is adjusted to 45 lbs of tension on a belt gauge for a new belt.
 - A used belt is re-tensioned to 28 lbs.
 - The replacement belt PN is 67-8510.
3. Loosen the jam nut that retains the anti-surge screw. Rotate the screw clockwise 1/8 of a turn at a time until the surging stops.
4. Check the low and high idle speed to be sure that there is no change in the initial settings. If the idle speed has increased, the anti-surge screw has been turned in too far and it must be backed out.

Other things to check when engine surges:

- A. Carburetor too rich or lean.
- B. Binding in the throttle linkage.
- C. Governor worn internally.

Governor Spread or Sensitivity Adjustment.

Governor spread is the difference between the no load governed speed, and the full load speed. For the governor to work correctly this spread should be 5 to 10 percent.

To check governor spread, check and record the no-load high idle speed and compare this to the loaded high idle speed.

To increase the spread adjust the adjustment bolt to position the spring farther away from the lever hub. To decrease the spread position the spring closer to the hub.

Notes

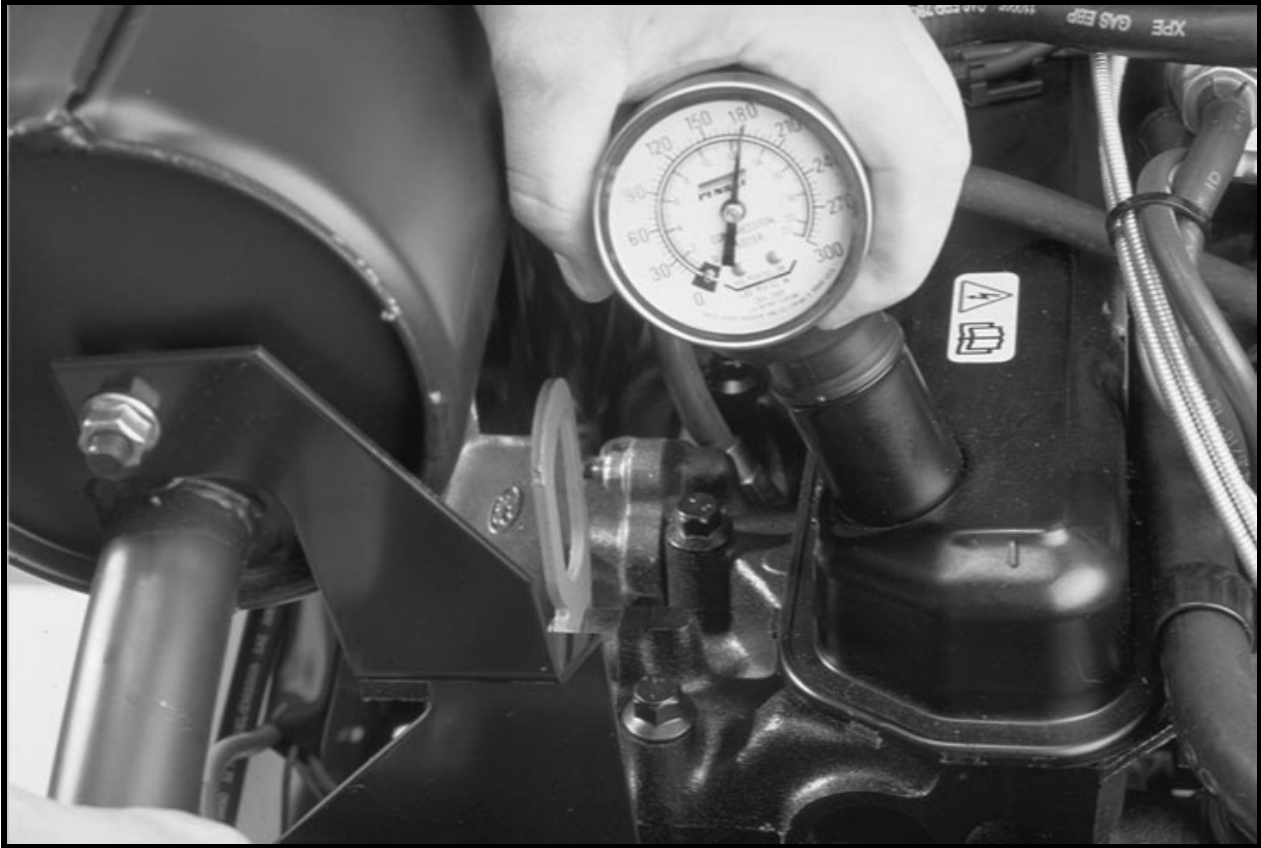
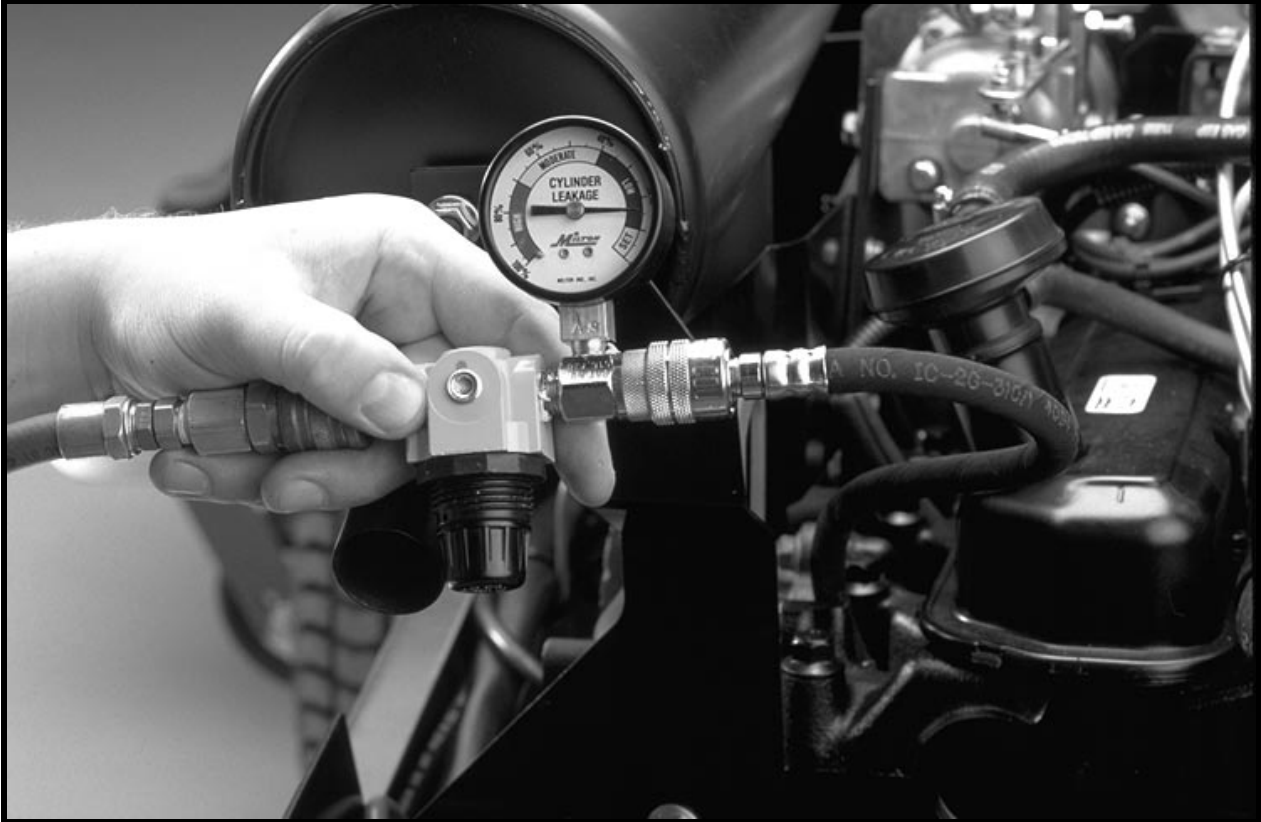

Special tools

1. Electric tach.
 - OTC P/N - OEM1386 or equivalent.
2. Photo tach.
 - OTC P/N - OEM1057 or equivalent.
3. Belt tension gauge
 - OTC P/N - OEM1294 or equivalent
4. Cylinder leakage tester.
 - OTC P/N - TOR4075 or equivalent.
5. Compression tester.
 - 0 - 300 psi.
 - OTC P/N - OEM1072, OEM 1073 or equivalent.

Helpful Hints

1. All engine RPM checks should be performed with the engine warm.
2. Governor oil is the same oil as is used in the crankcase
3. Cylinder leakage can identify the location and the extent of an internal engine problem
 - Cylinder leakage of 25 percent or less is acceptable
4. When checking engine compression the throttle and the choke must be fully open to insure an accurate reading
5. Normal engine compression at cranking speed is 185 PSI.
6. The actual compression reading is not as important as the relationship between all the cylinder readings.
7. Part Numbers
 - Engine oil filter, Motorcraft P/N FL.400-A.
 - Fuel filter, Motorcraft P/N FG795A.
 - Air filter Toro P/N 27-7110

Review Questions

1. Proper high idle setting is:
 - a. 2800 ± 50 RPM
 - b. 3200 ± 100 RPM
 - c. 3000 ± 25 RPM
 - d. 1500 ± 100 RPM
2. The final high idle adjustment is made at the carburetor.
 - a. True
 - b. False
3. The recommended compression gauge is:
 - a. 0 - 100 PSI
 - b. 0 - 200 PSI
 - c. 0 - 300 PSI
 - d. 200 - 400 PSI
4. Normal engine compression is:
 - a. 100 PSI
 - b. 205 PSI
 - c. 185 PSI
 - d. 415 PSI
5. Adding oil to a cylinder with a bad intake valve will increase the compression reading of the cylinder.
 - a. True
 - b. False
6. When performing a leakage test, air leaking from the breather indicates :
 - a. Leaking intake valve.
 - b. Leaking exhaust valve.
 - c. Leaking head gasket.
 - d. A normal situation

Notes

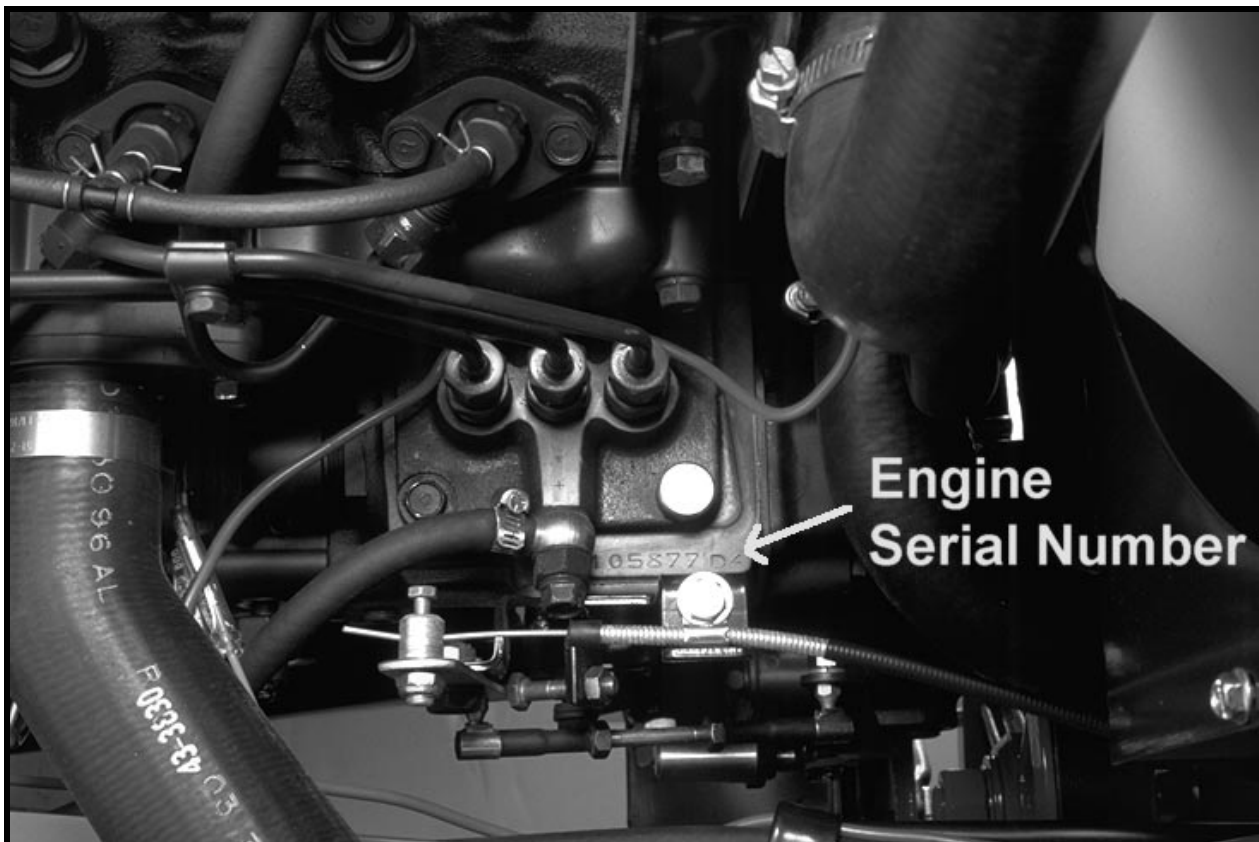
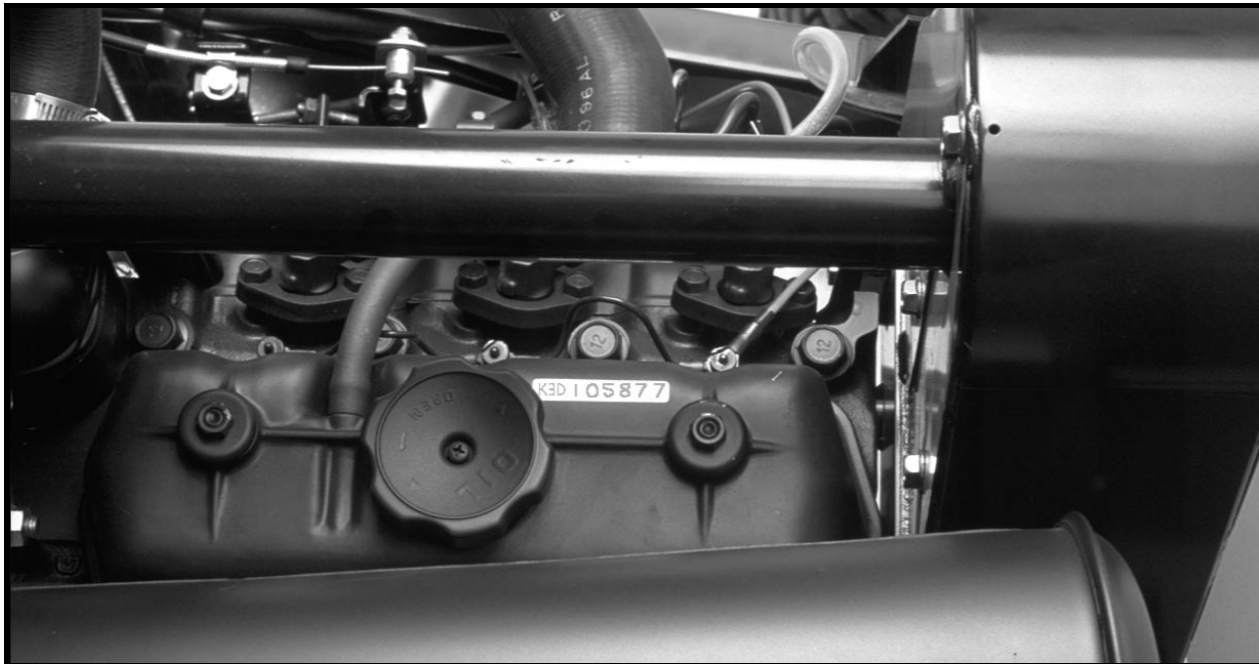

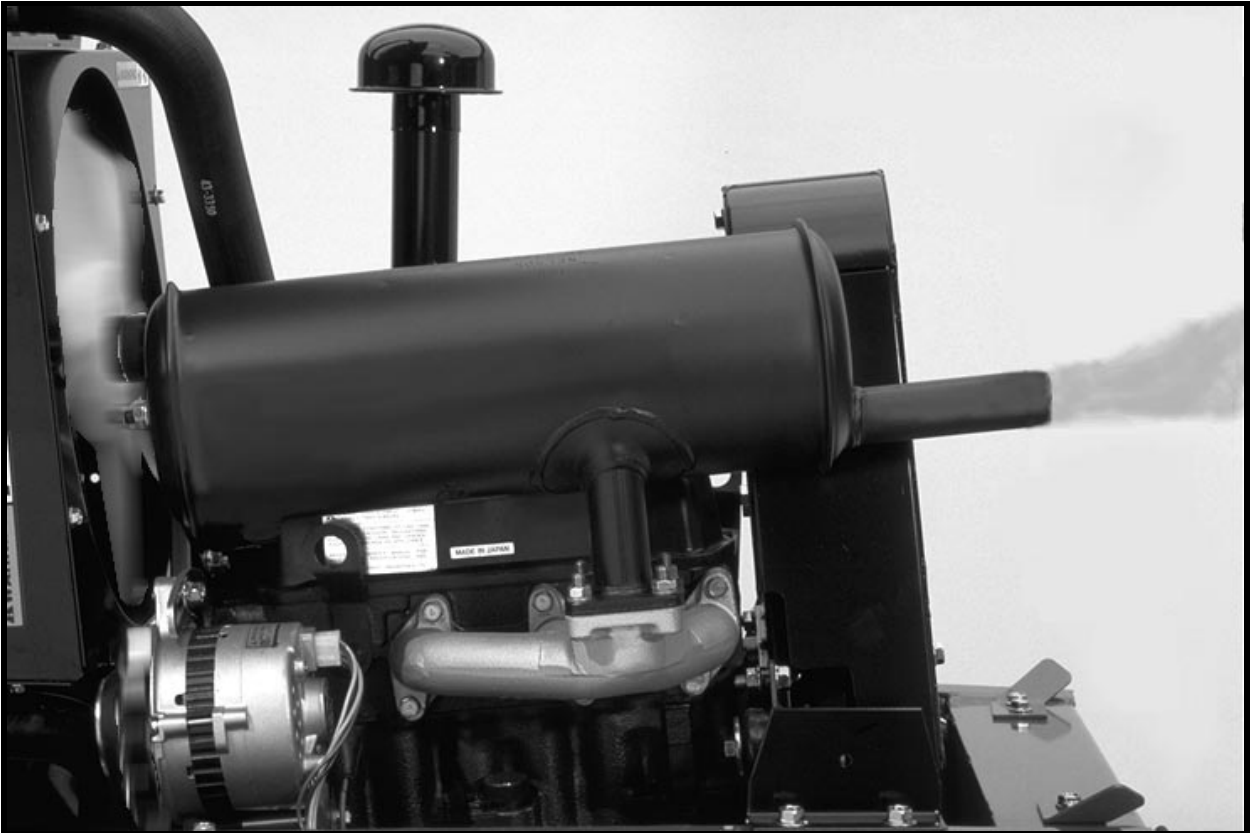
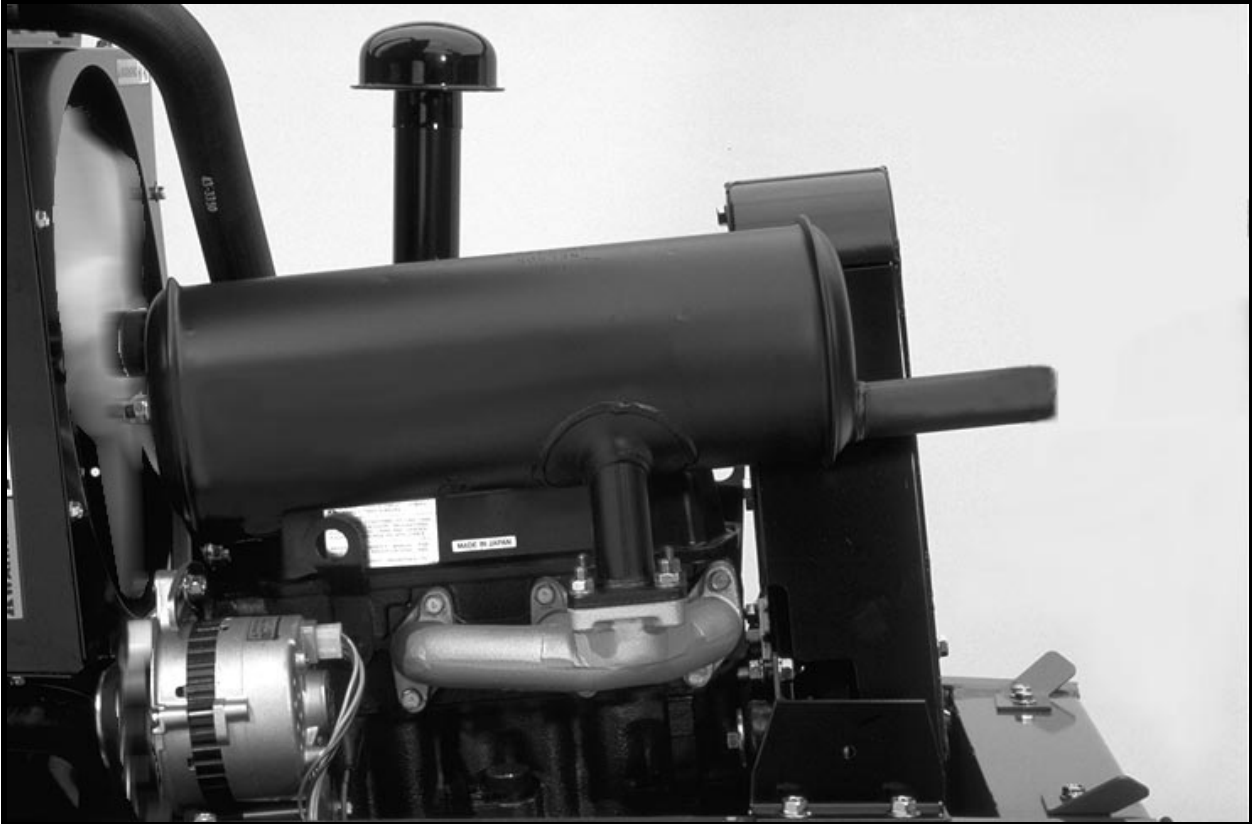

Analyzing Diesel Exhaust Smoke.

The exhaust from a diesel engine can provide information about the running condition of the engine. A normally operating engine will have exhaust that is clear to a slight brownish/gray color.

- 1. Black Smoke.
 - Insufficient air.
(Plugged or dirty air filter)
 - Excessive fuel.
(Leaking injection nozzles)
(Over fueled injection pump setting)
 - Engine Overloaded.
(Excessive load on engine)

- 2. Blue Smoke.
 - High engine oil consumption.
(Worn rings or valve guides)
(Plugged crankcase breather)

- 3. White Smoke.
 - Water in combustion chamber.
(Leaking head gasket)
(Cracked cylinder head or cylinder wall)

White smoke can also be caused by the following:

- Incorrect injection timing.
- Low compression.
(Incomplete combustion)
- Low cylinder temperature.
(Faulty glow plugs)
(low ambient air temperature)
Note: White smoke may dissipate when engine warms up.

Notes

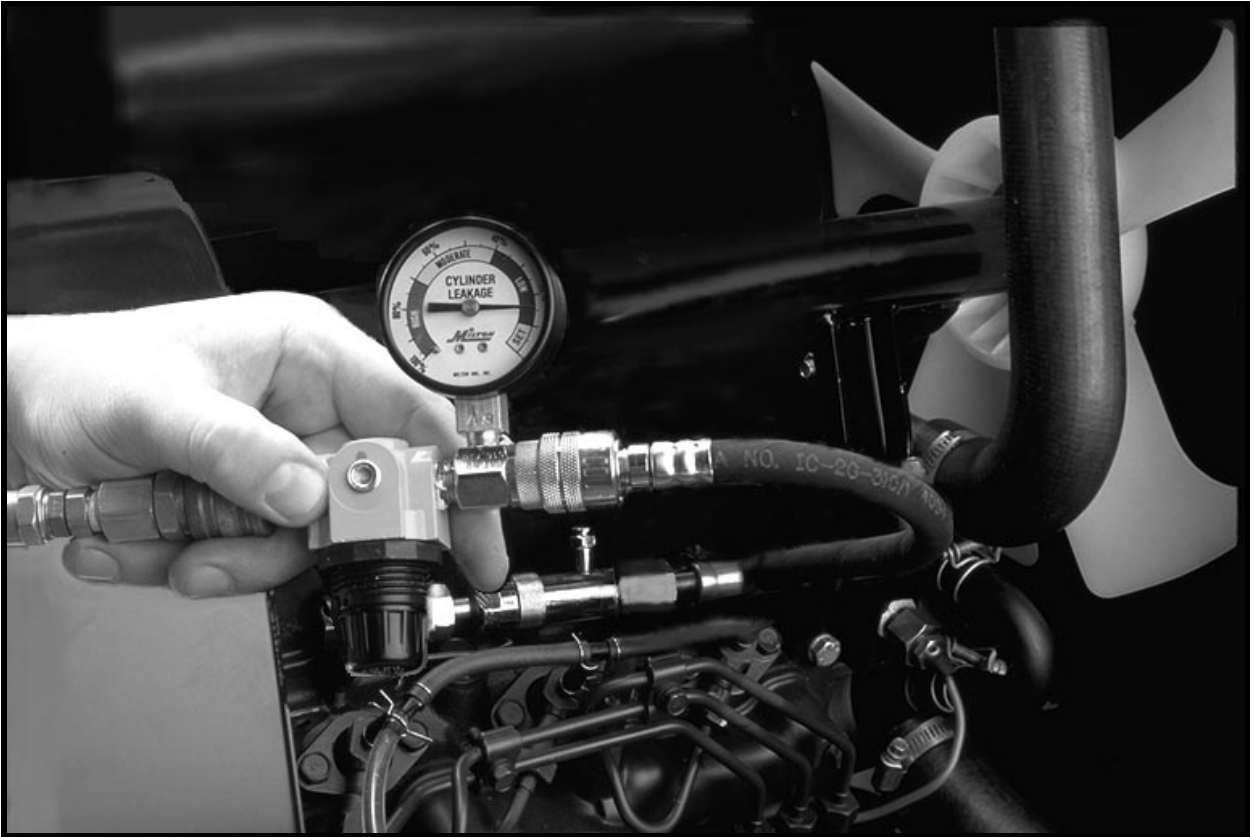

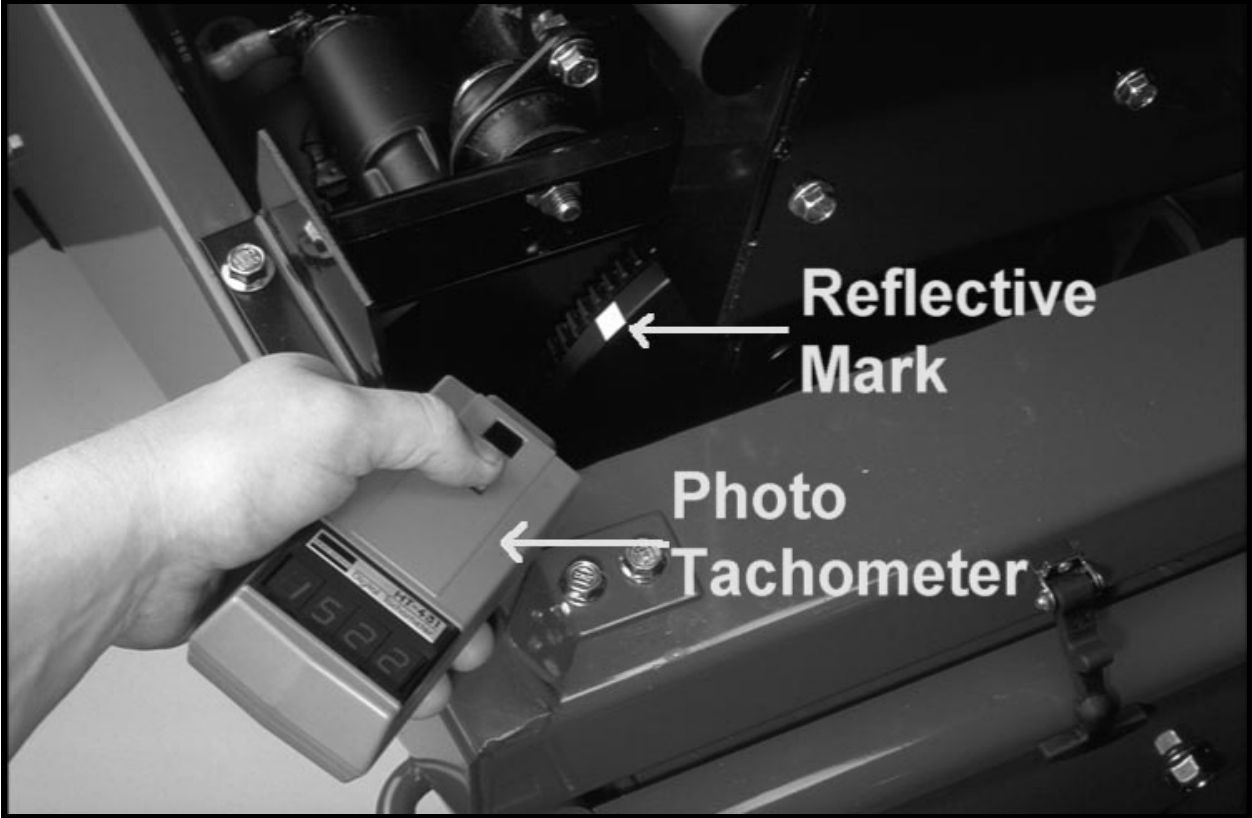



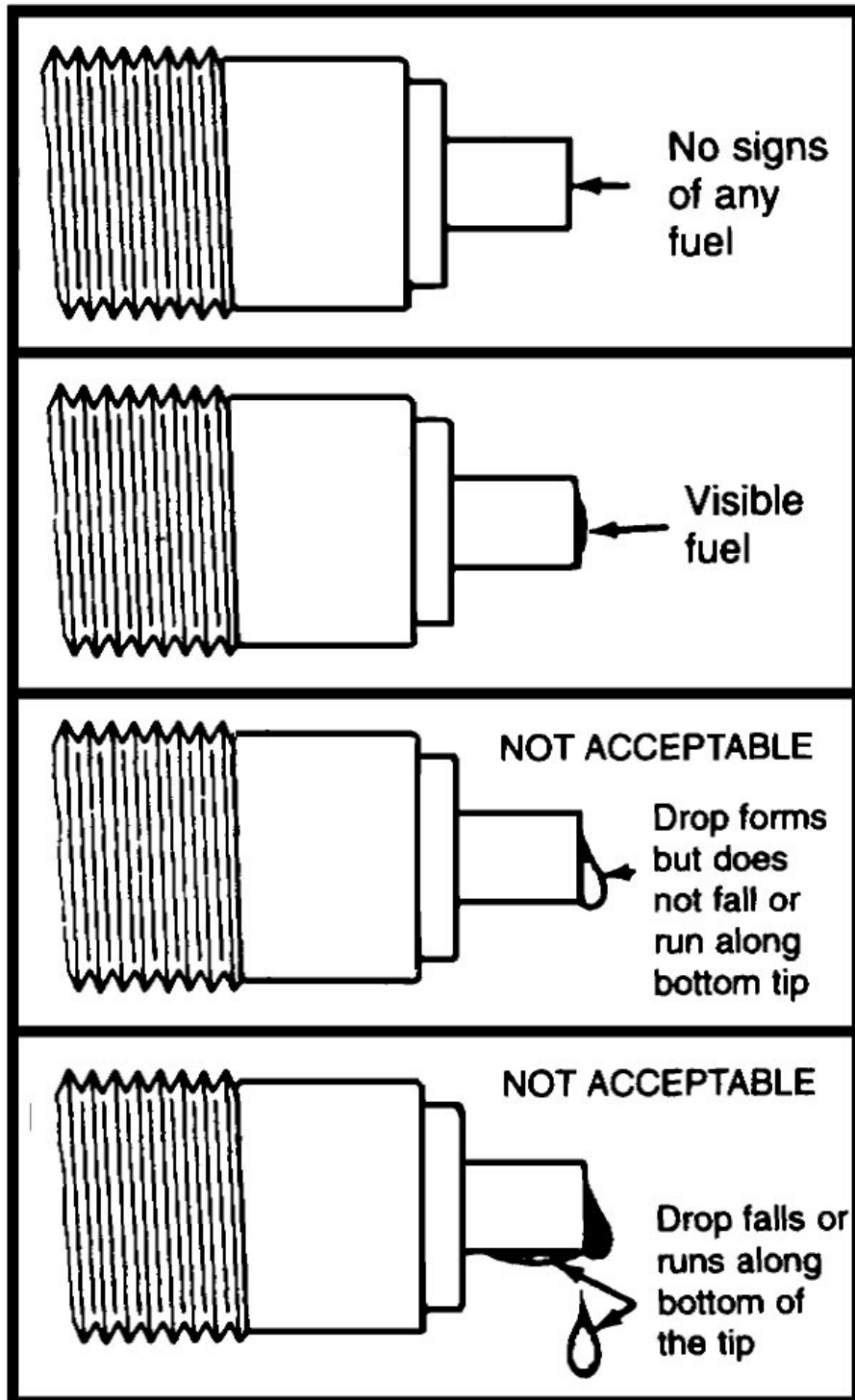

1. Nozzle Leakage Test.
 - The leakage test checks the nozzle tip for proper sealing.
 - A leaking nozzle should be repaired or replaced.
2. Operate the pump until 1500 psi (108 kg/cm²) is reached, maintain this pressure.
3. Check the nozzle end.
 - If the nozzle end is dry or a slight film of fuel is present, the nozzle is OK.
 - If a drop of fuel forms or the nozzle drips fuel, the nozzle must be serviced or replaced.

Notes

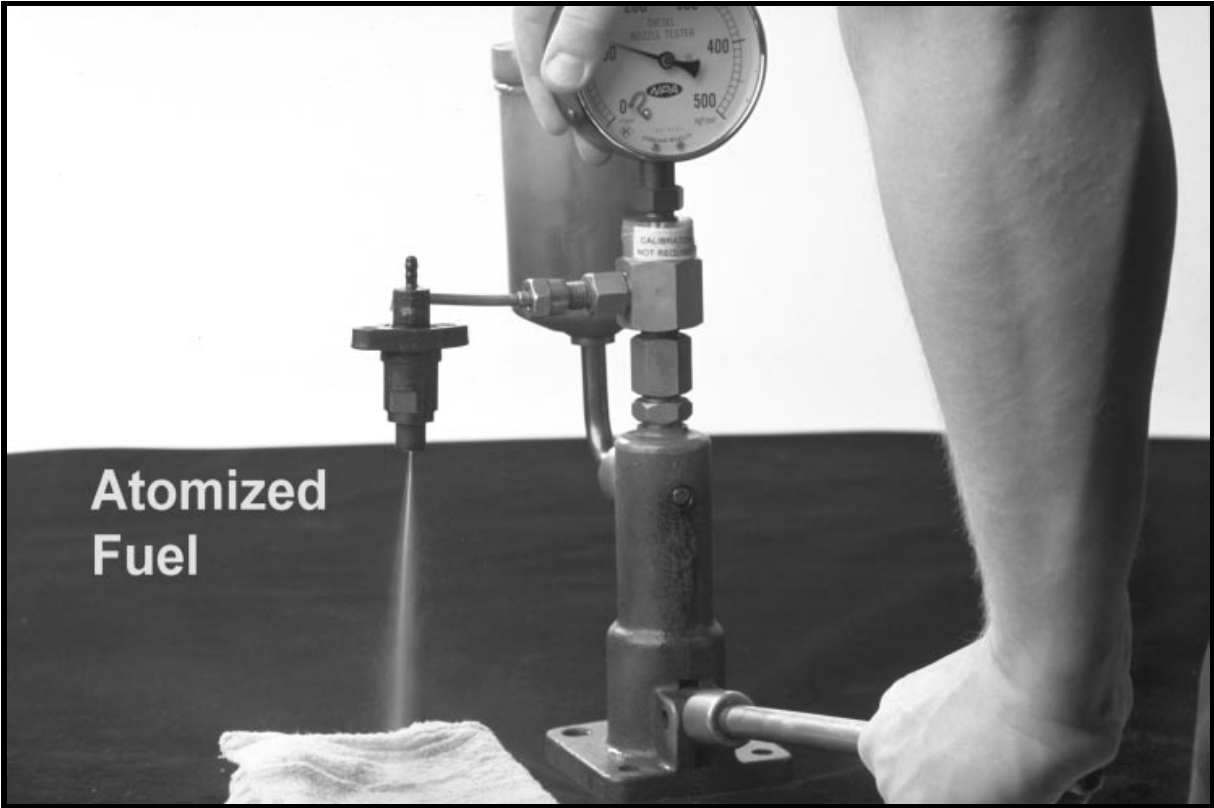
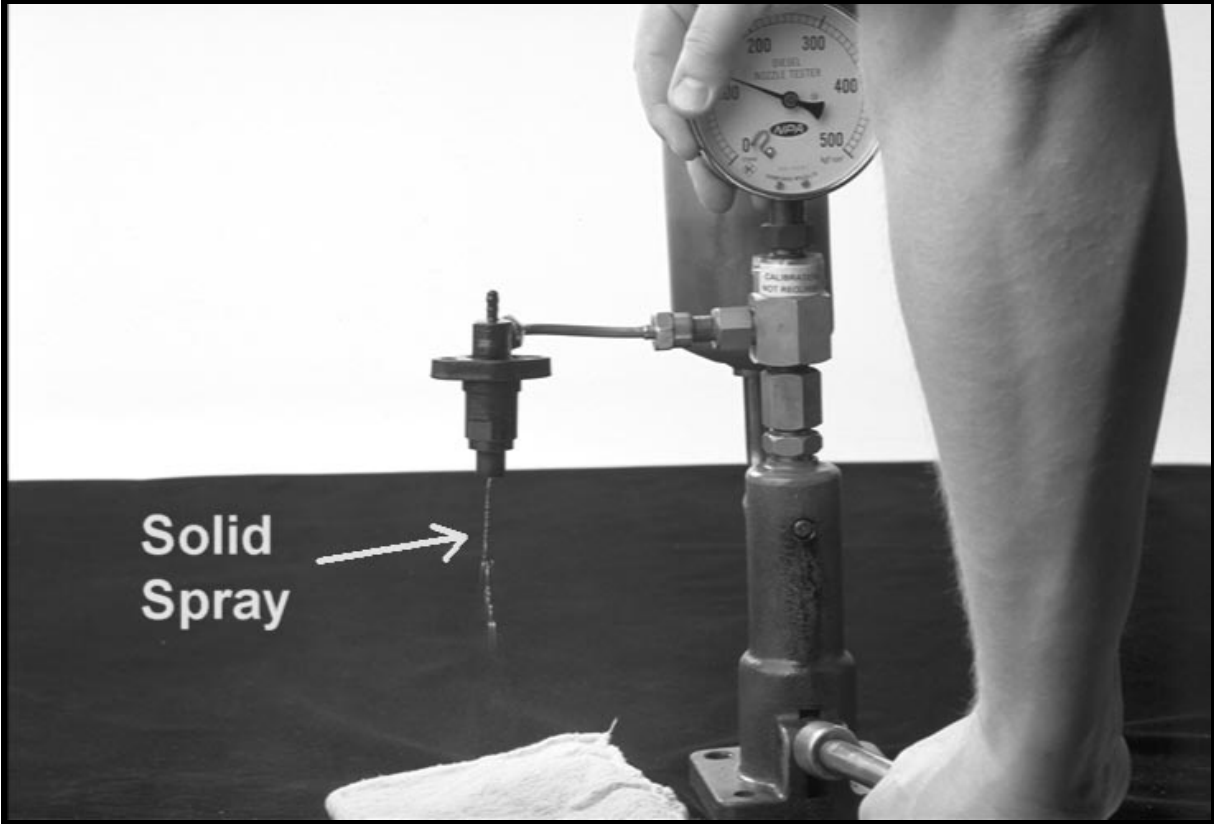



Special Tools

1. Photo tach.
 - OTC P/N - OEM1057 or equivalent.
2. Belt tension gauge
 - OTC P/N OEM1294 or equivalent
3. Cylinder leakage tester.
 - OTC P/N TOR4075 or equivalent.
4. Compression tester.
 - 0 - 1000 psi.
 - OTC P/N - TOR3003 or equivalent.
 -
5. Injection Nozzle Tester
 - OTC P/N TOR463610 or equivalent

Service Tips

1. All engine RPM checks should be performed with the engine warm.
2. Cylinder leakage can identify the location and the extent of an internal engine problem
 - Cylinder leakage of 25 percent or less is acceptable
3. When checking engine compression the verify the engine cranking speed to insure an accurate reading
4. Normal engine compression at cranking speed is 455 PSI.
5. The actual compression reading is not as important as the relationship between all the cylinder readings
6. Part Numbers
 - Engine oil filter, Toro P/N 42-9030
 - Fuel filter/Water separator
Toro P/N 63-8300
 - Fuel pump filter Toro P/N 43-2550
 - Air filter Toro P/N 27-7110

Study Questions

- 1. Blue exhaust smoke indicates :
 - a. Excessive fuel
 - b. water in the combustion chamber.
 - c. High oil consumption.
 - d. Excessive engine load.
- 2. When performing a compression test, add oil to the pistons before the test
 - a. True
 - b. False
- 3. Proper low idle setting is:
 - a. 1000 ± 100
 - b. 1000 ± 50
 - c. 1500 ±100
 - d. 1500 ± 50
- 4. Cylinder leakage of 50 % is acceptable
 - a. True
 - b. False
- 5. Maximum injection nozzle opening pressure is:
 - a. 1750 psi
 - b. 1850 psi
 - c. 1950 psi
 - d. 2000 psi
- 6. Injection nozzles should spray fuel in a solid stream with large droplets.
 - a. True
 - b. False

Notes

Drive circuit

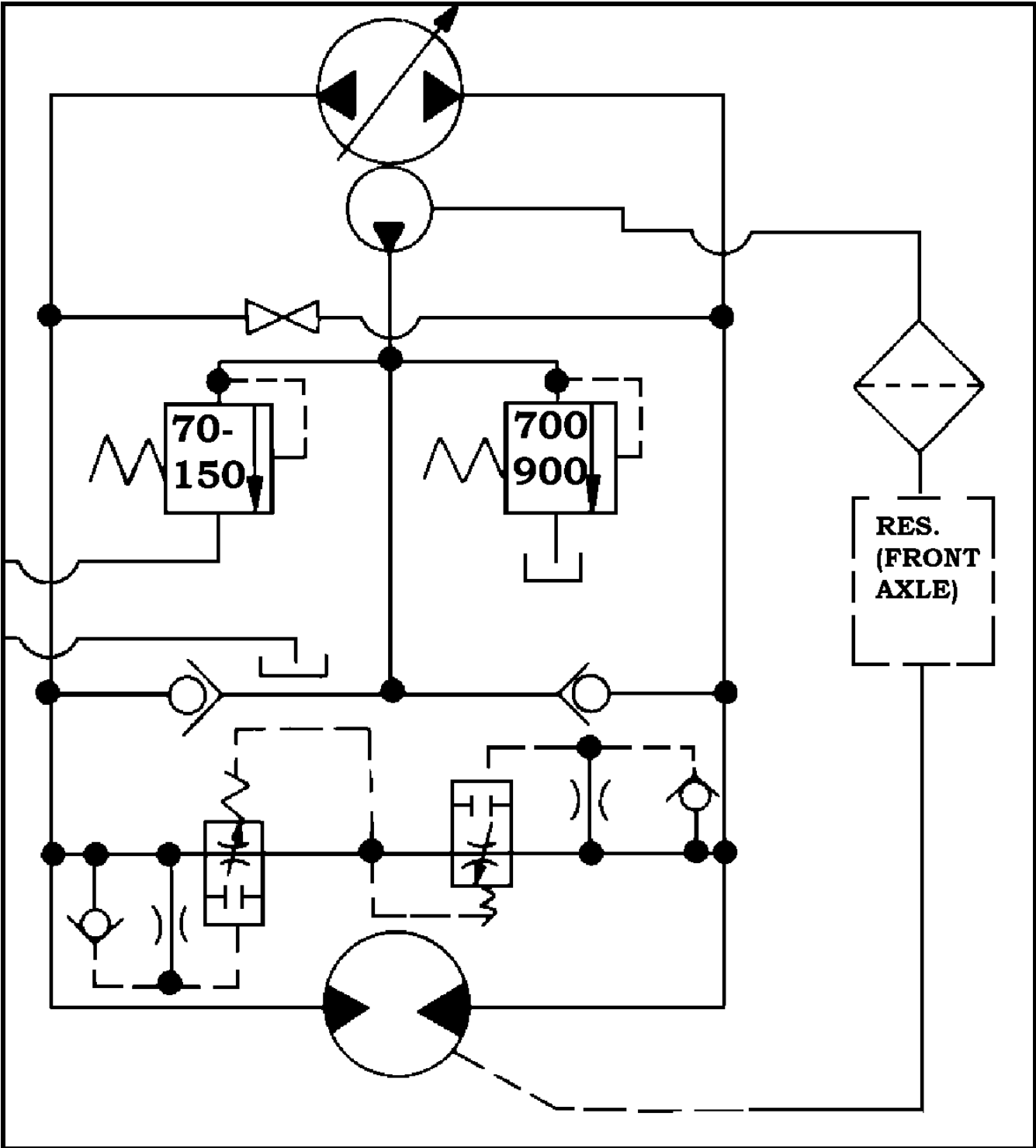

Acceleration valves

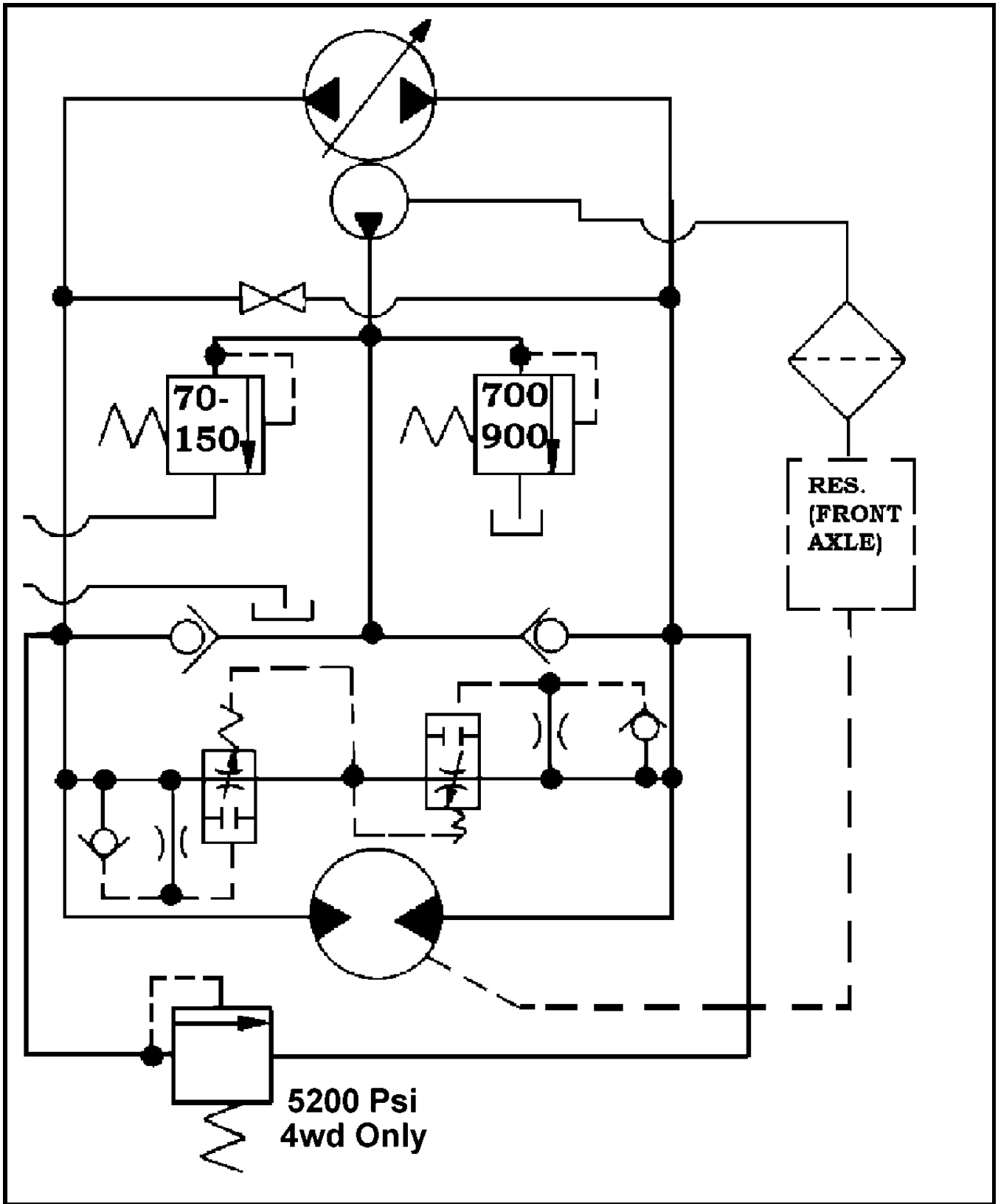

Acceleration valves

1. The drive oil from the hydrostatic pump also flows to the acceleration valves.
2. The oil is allowed to flow through the orifice in the valve, until sufficient pressure is created to close the acceleration valve.
3. Bleeding away some of this initial oil flow allows for a smoother unit start and direction change.
4. The acceleration valves do not serve as the drive circuit relief valve.
5. The 2 wheel drive unit does not have a relief valve.

Relief Valve

The 4 wheel drive unit has an externally mounted relief valve.
The relief valve only regulates the oil pressure in the forward direction.

Notes

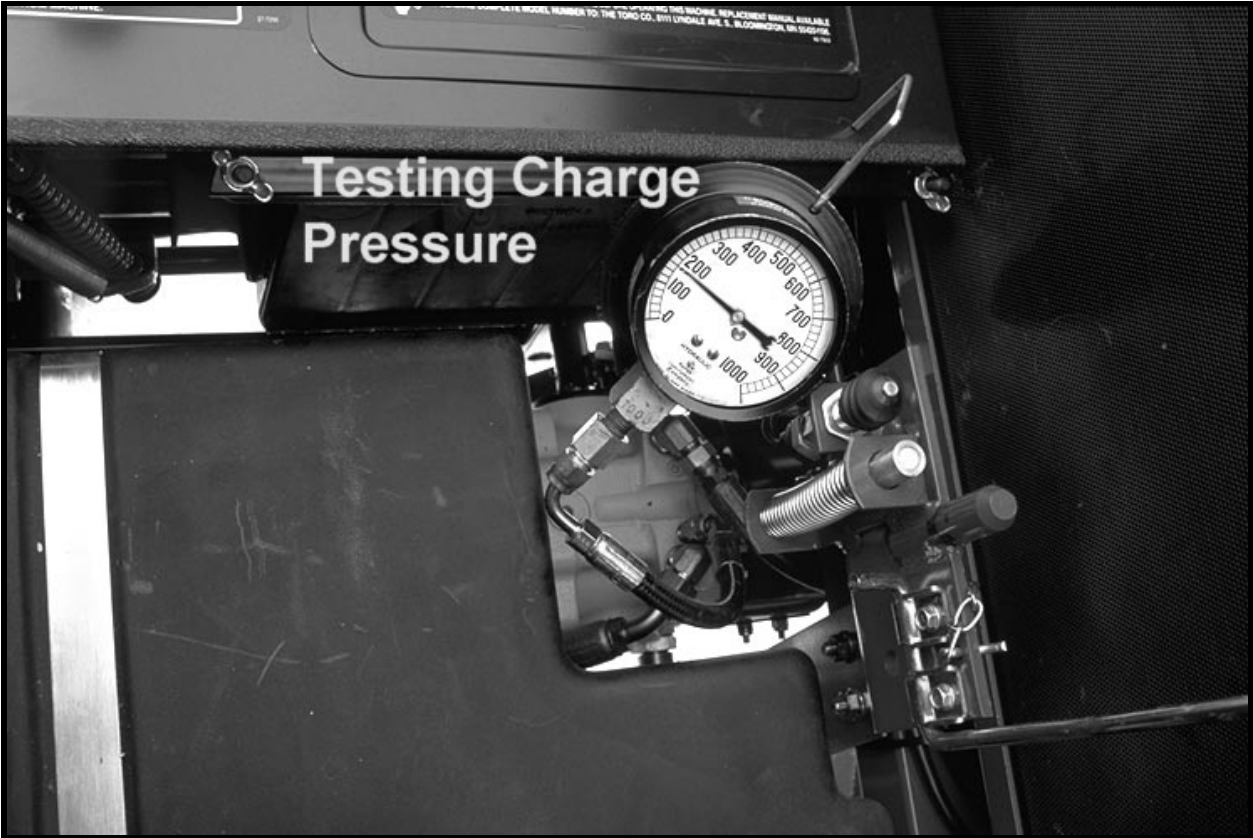
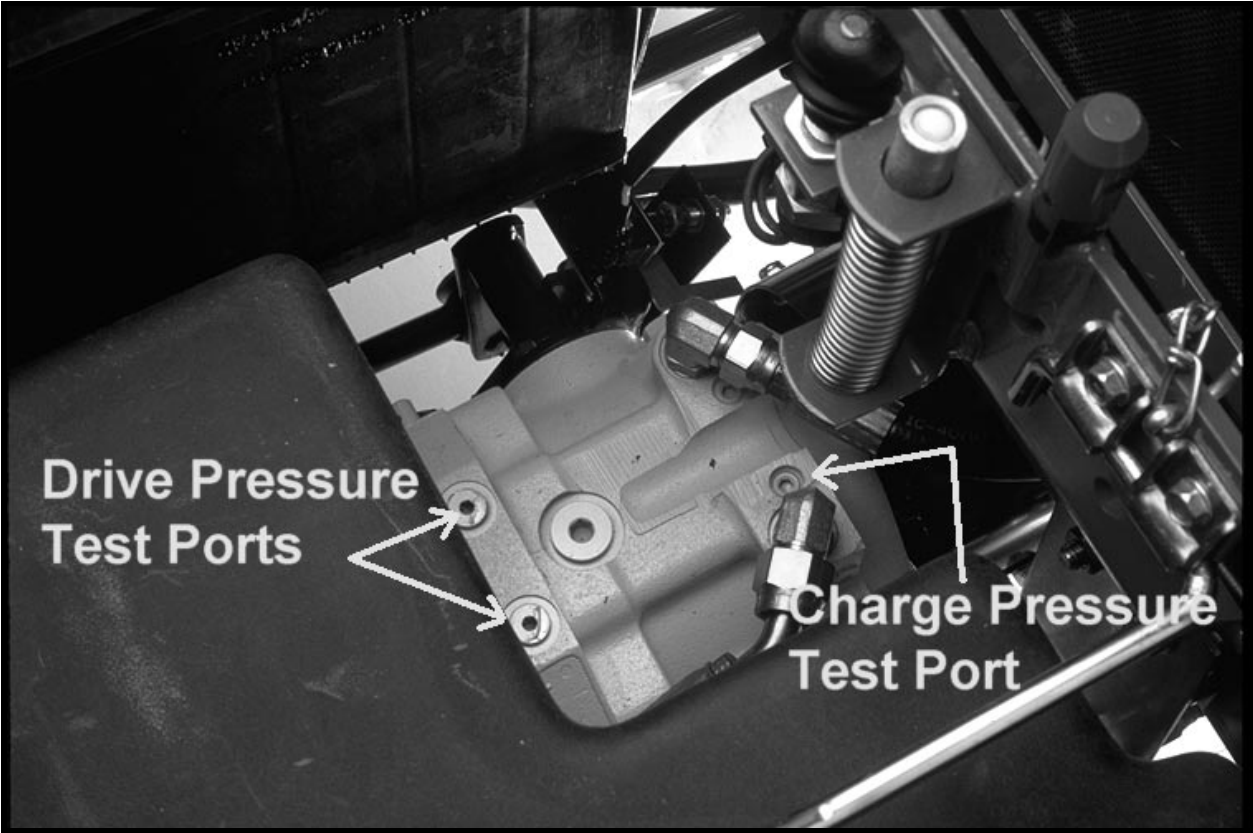

Drive Pressure Test

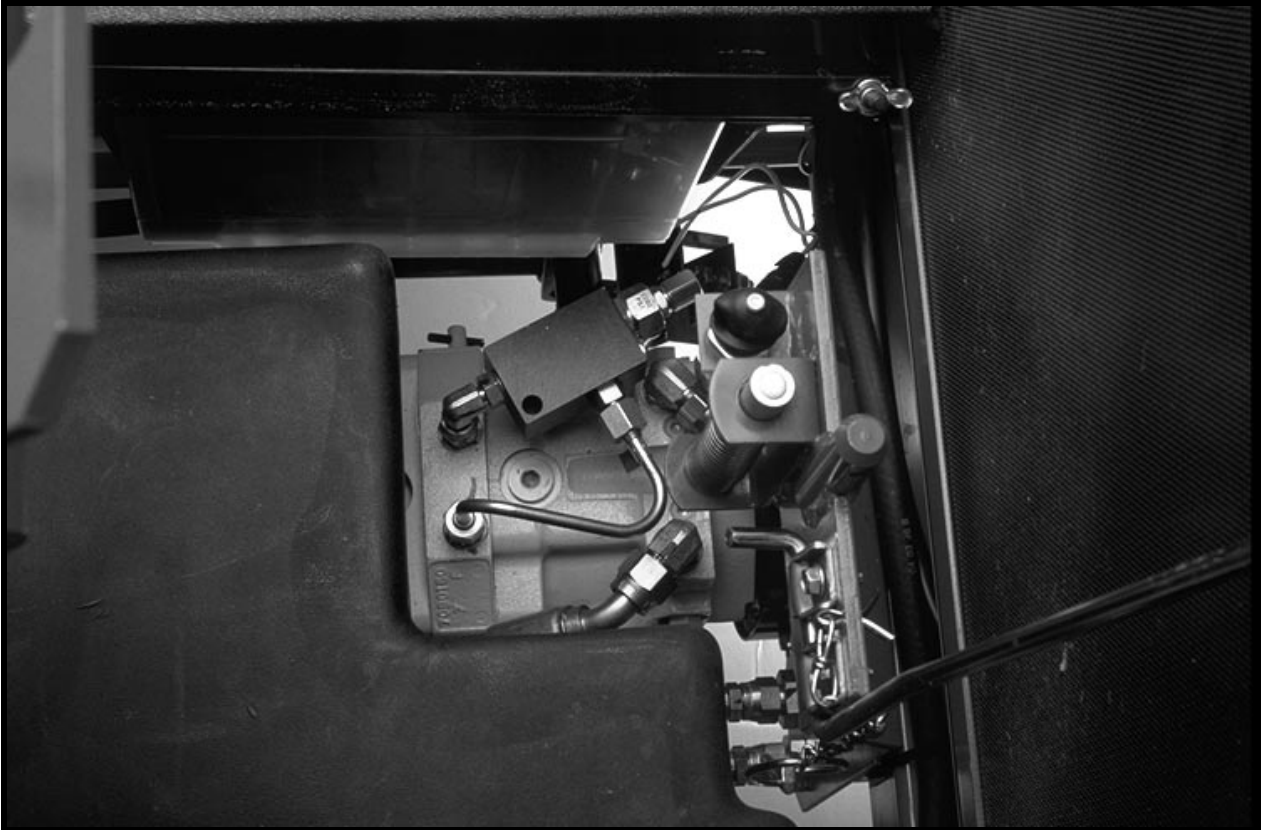
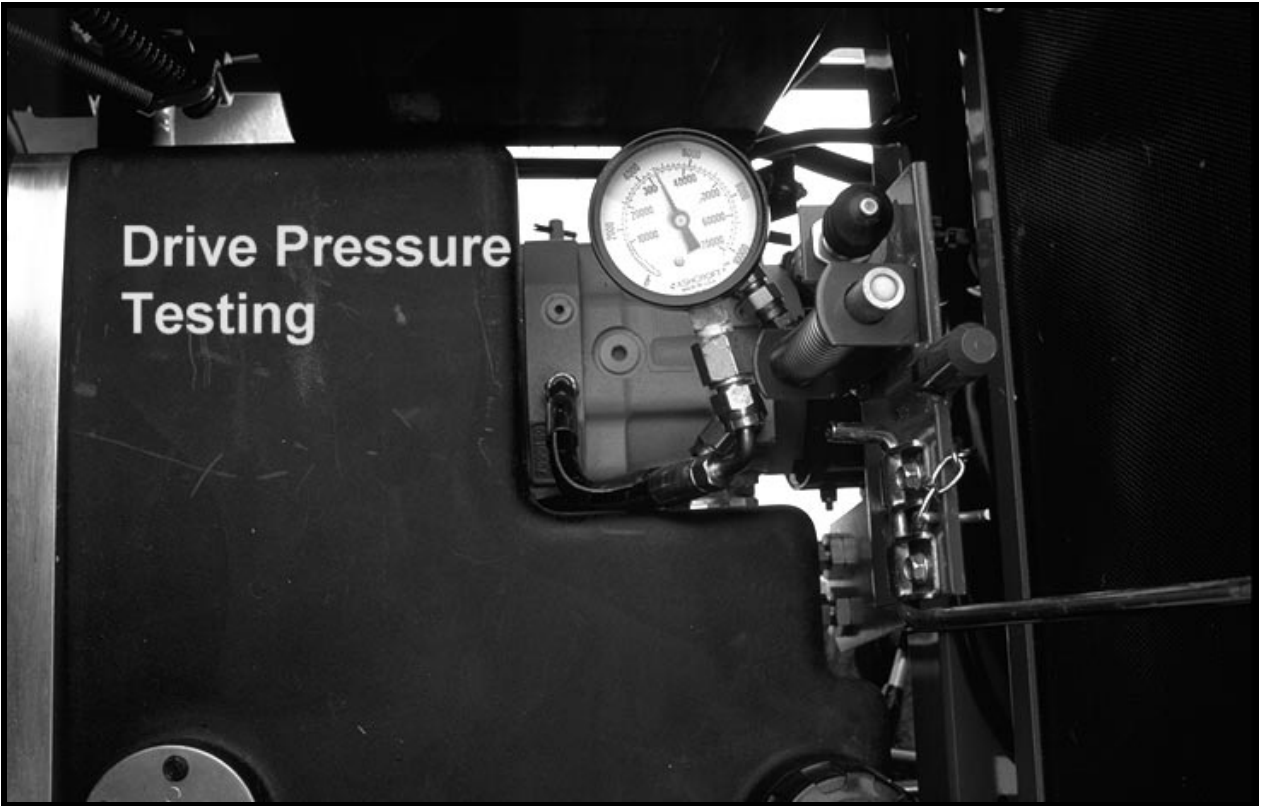

Charge Flow Test

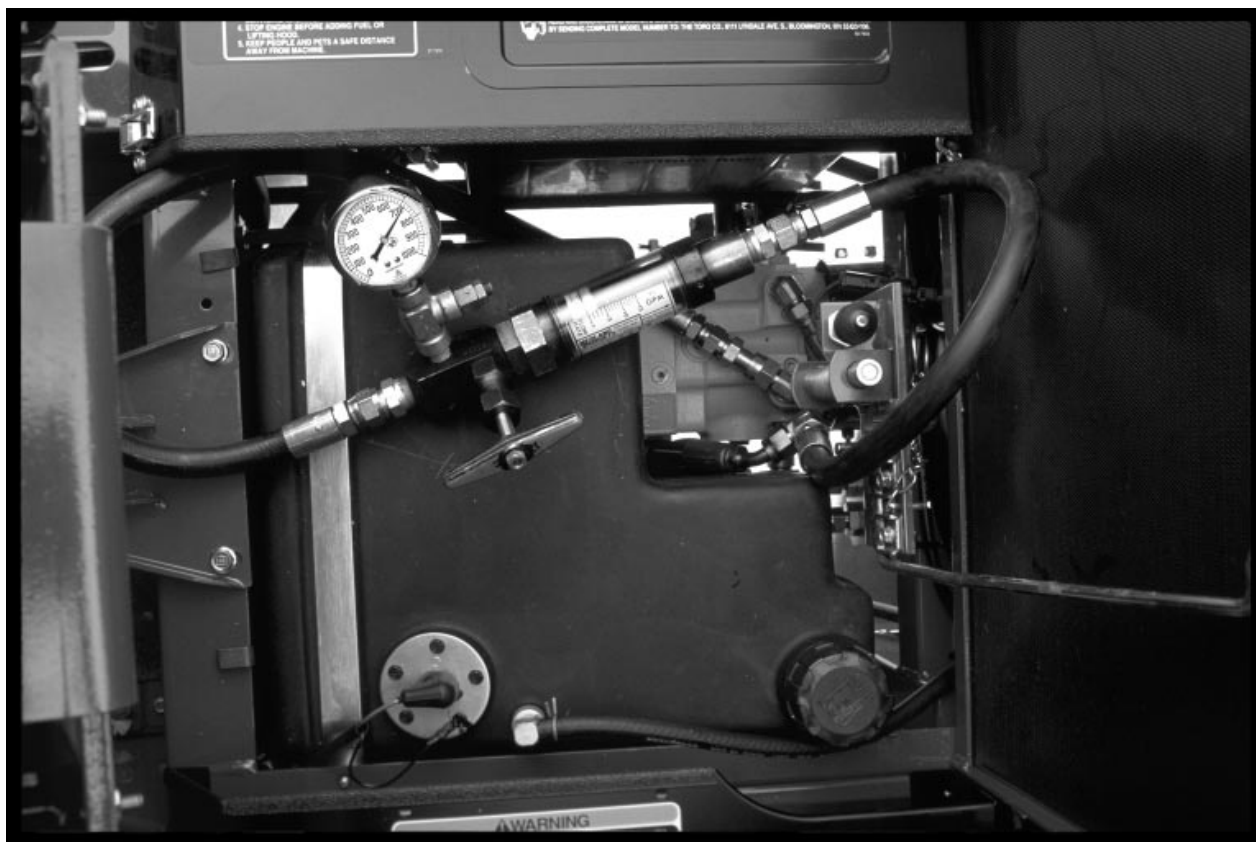

1. Testing charge flow.
 - Connect hydraulic flow meter.
 - Operate engine at 3200 RPM.
 - Restrict oil flow through flow tester. Should be able to read 1GPM at 700 PSI.

Low charge flow (charge pressure “OK”)

2. Possible causes:
 - Leaking implement relief valve.
 - Worn drive pump.
 - Worn drive motor.
3. Performance results:
 - Slow steering response.
 - Slow hydraulic response.
 - System overheating. (low oil cooler flow)

Notes

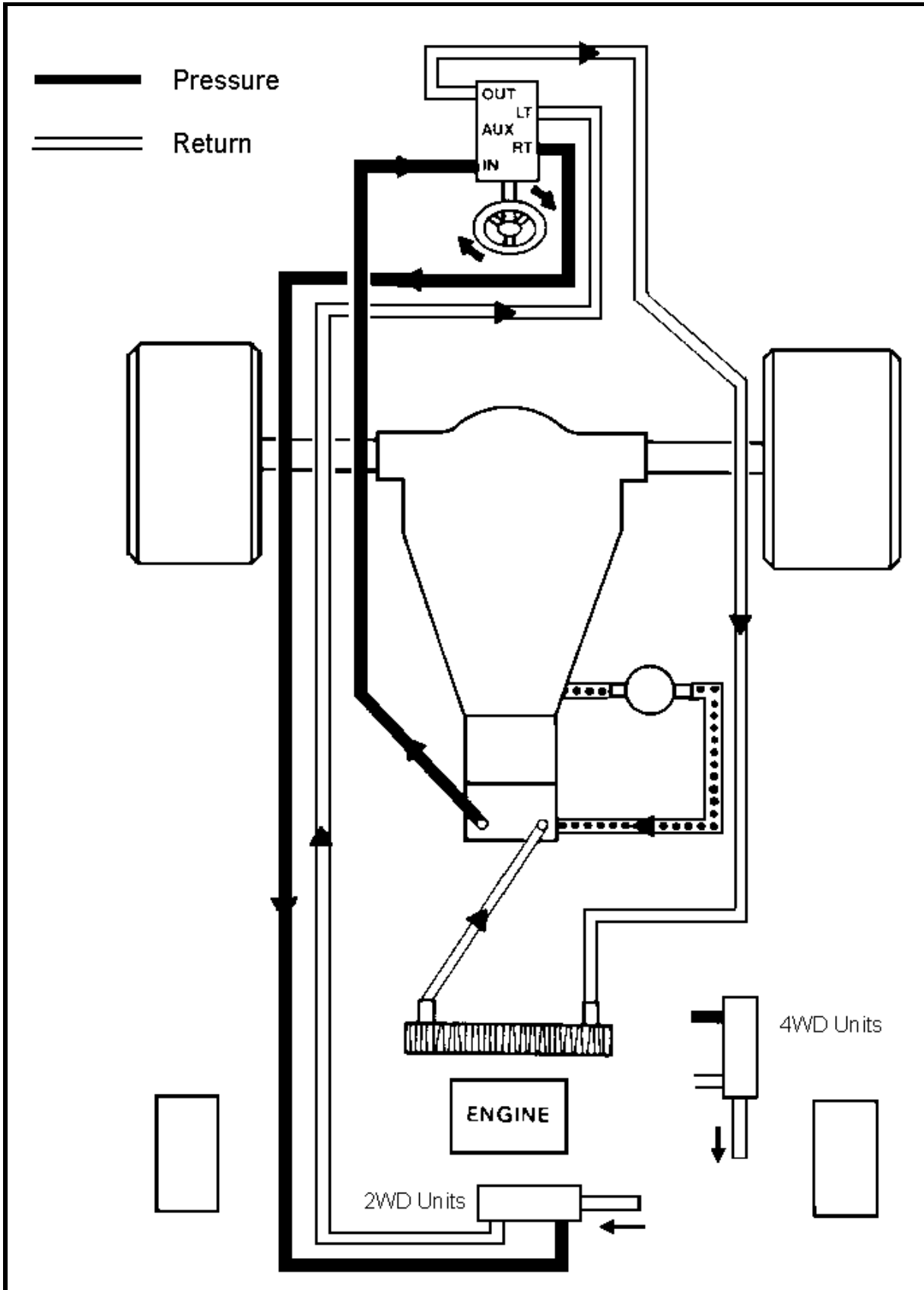

Steering Circuit

1. Oil from the hydrostatic charge pump flows to the IN port of the steering valve.
2. With the steering wheel in neutral the oil flows out the AUX port to the lift valve.
3. When the steering wheel is turned to the right the AUX port is closed and oil is directed out the RT port to the steering cylinder.

NOTE: The steering valve will not allow oil to flow through it to the lift valve when the steering wheel is being turned.

Notes

Special Tools

1. Hydraulic flow tester kit
 - OTC P/N TOR214678 or equivalent
2. Hydraulic pressure test kit.
 - OTC P/N TOR47009 or equivalent

Service Tips

1. Hydraulic testing is done with the hydraulic oil at normal operating temperature.
2. Before testing hydraulics check the system for the proper oil level and fluid type.
3. Check or replace the hydraulic filter to eliminate the possibility of a plugged filter.

Study Questions

1. All hydraulic and hydrostatic test should be conducted with the oil warm.
 - a. True
 - b. False
2. Proper engine RPM for hydraulic testing is:
 - a. 1500 RPM
 - b. 2000 RPM
 - c. 3000 RPM
 - d. 3200 RPM
3. Proper maximum drive pressure for a 2wd unit is:
 - a. 2000 PSI
 - b. 2000 - 3000 PSI
 - c. 4000 - 4500 PSI
 - d. 5000 - 5500 PSI
4. The acceleration valves prevent:
 - a. Abrupt direction change
 - b. Excessive drive pressure
 - c. Loss of charge pressure
 - d. Excessive travel speed
5. Drive pressure is tested with a:
 - a. 1000 PSI gauge
 - b. 3000 PSI gauge
 - c. 5000 PSI gauge
 - d. 10,000 PSI gauge
6. The steering circuit gets its oil flow before the cutting unit lift circuit.
 - a. True
 - b. False

Notes

Start Circuit

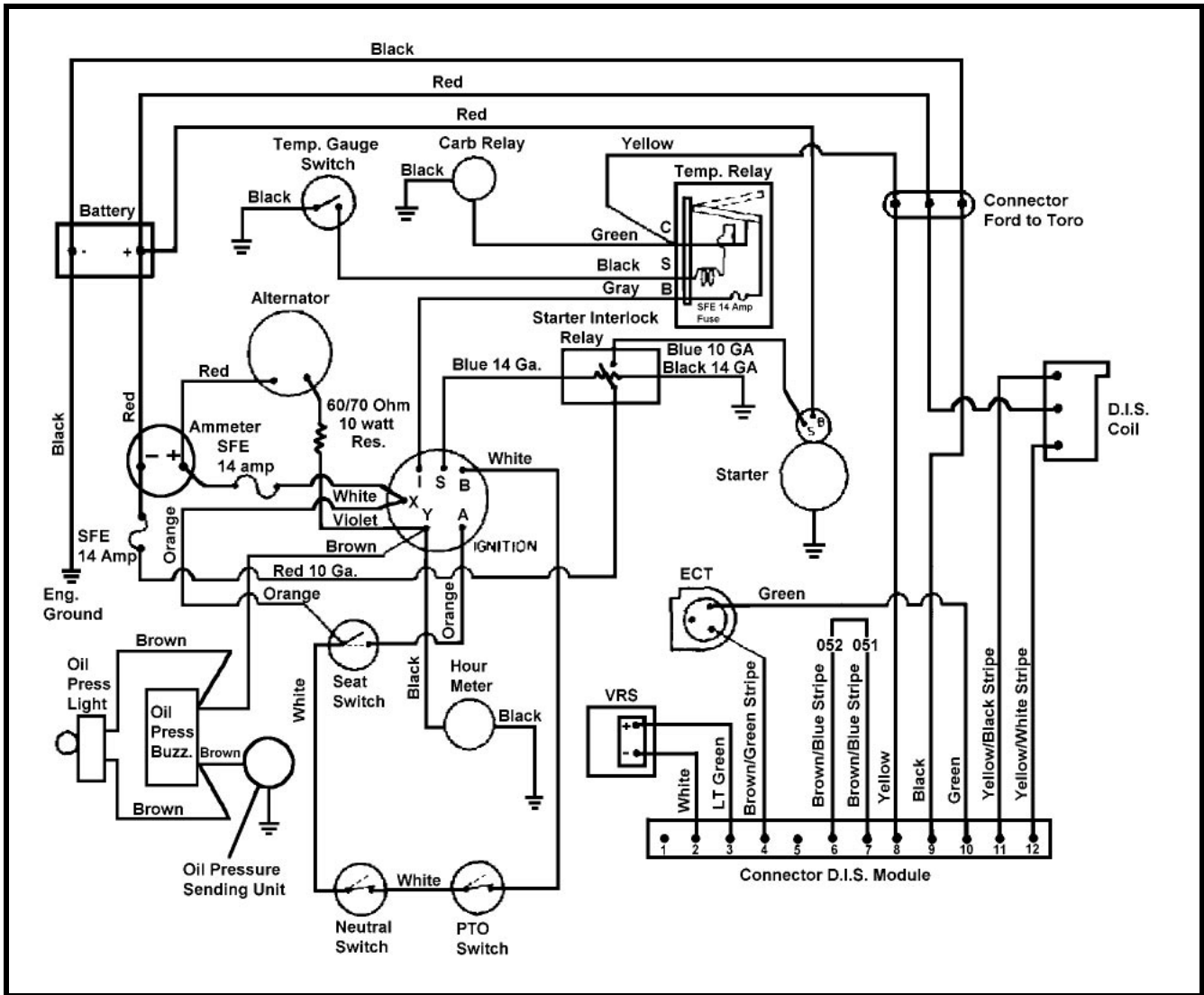

	Position	Circuit	Make
1	OFF	NONE	
2	ON	B + I + A	X + Y
3	START	B + I + s	

Electrical System (GM 345 / 325-D)

The electrical system on the 300 Series Groundsmaster can be broken into the following circuits:

1. Starting/Charging.
2. Safety Interlock.
3. Gauges and warning.
4. Engine.

With a basic understanding of these circuits we can troubleshoot a variety of electrical problems.

System Operation

Start Circuit. (GM 345 Shown, 325-D similar)

1. Power from the battery flows to the (-) terminal of the ammeter.
2. The power flows from the (+) terminal of the ammeter to the ignition switch, terminal (X).
3. The power splits and flows to the seat switch.
4. The power splits again and flows to the neutral switch and PTO switch.
5. When both switches are closed the power can flow to the (B) terminal of the ignition switch.
6. When the switch is turned to the start position power flows from the (B) terminal to the (S) terminal.
7. The power then flows to the starter relay and the relay sends power to the starter which cranks the engine.
8. Power is also directed out of the (I) terminal the temperature relay. From the temperature relay the power is directed to the D.I.S. ignition module and the carb relay.

Notes

Interlock Circuit

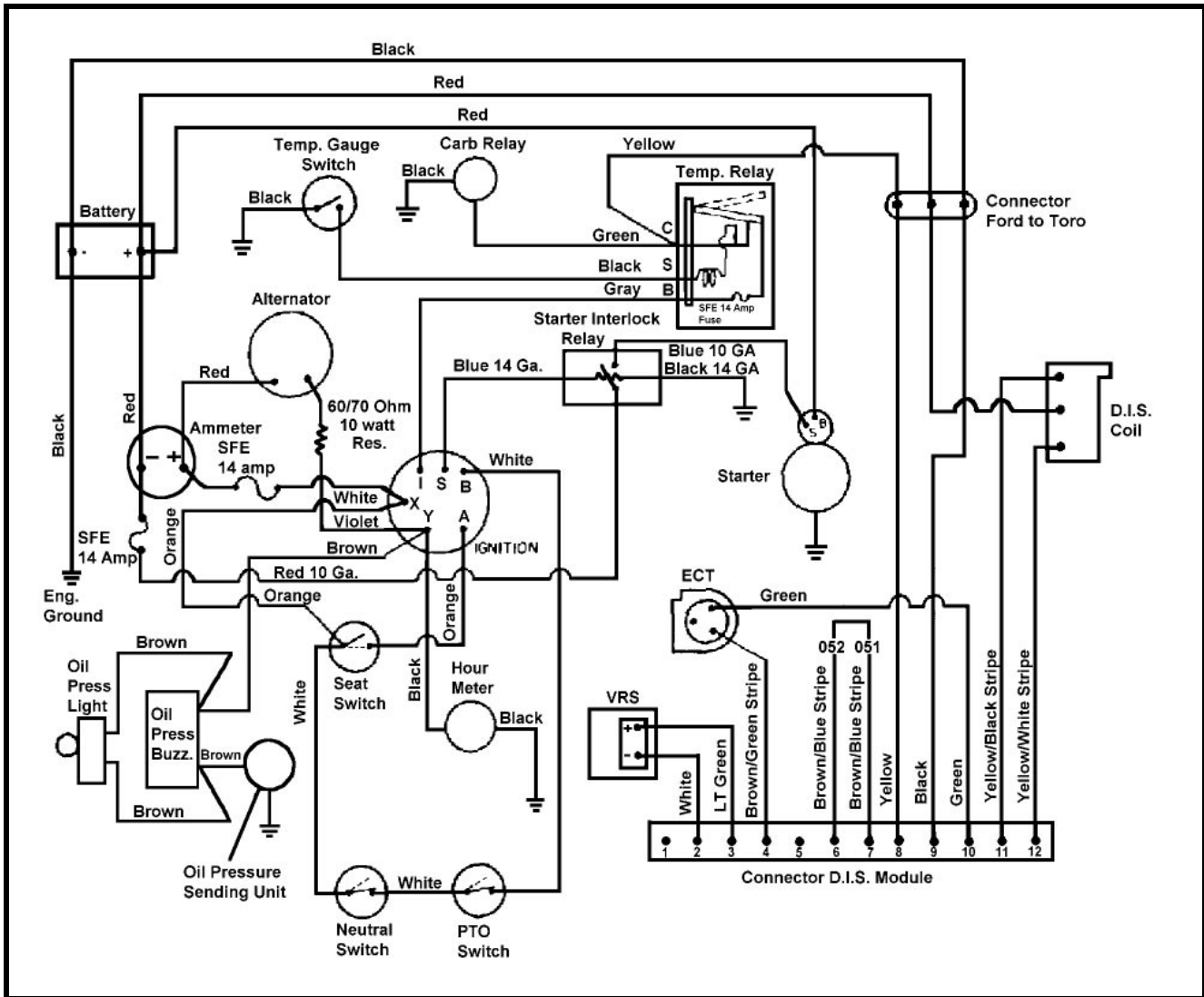

	Position	Circuit	Make
1	OFF	NONE	
2	ON	B + I + A	X + Y
3	START	B + I + s	

Interlock Circuit

Normal Operation.

1. With an operator in the seat and the PTO engaged, the PTO switch opens.
2. Current flows through the seat switch to the "A" terminal of the ignition switch.
3. In the run position, the power flows from the "A" terminal to the "I" terminal.
4. From the "I" terminal power flows to the ignition system.

Notes

Interlock Circuit

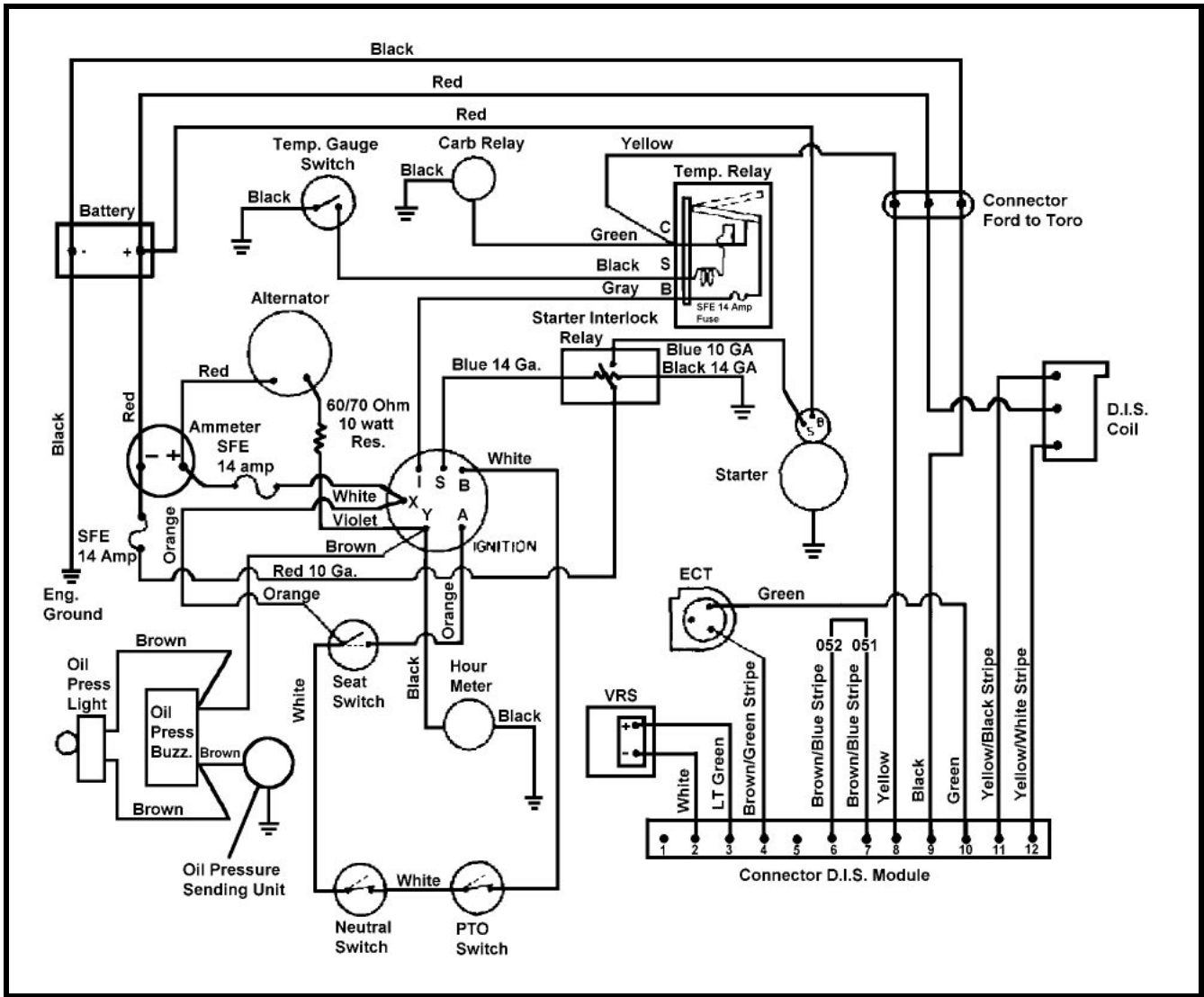

	Position	Circuit	Make
1	OFF	NONE	
2	ON	B + I + A	X + Y
3	START	B + I + s	

PTO Engaged, Operator Not In The Seat.

1. If the operator leaves the seat while the PTO is engaged.
2. Power is interrupted by the seat switch.
3. Current stops flowing to the "A" terminal of the ignition switch.
4. Power is stopped to the ignition module and the engine stops.

Caution: Do not disconnect the safety switches because they are there for the operators protection. Check the operation of the switches daily to be sure the interlock system is operation correctly. If a switch is malfunctioning, replace it before operating the machine. Replace the switches every 2 years to be sure of maximum safety.

Notes

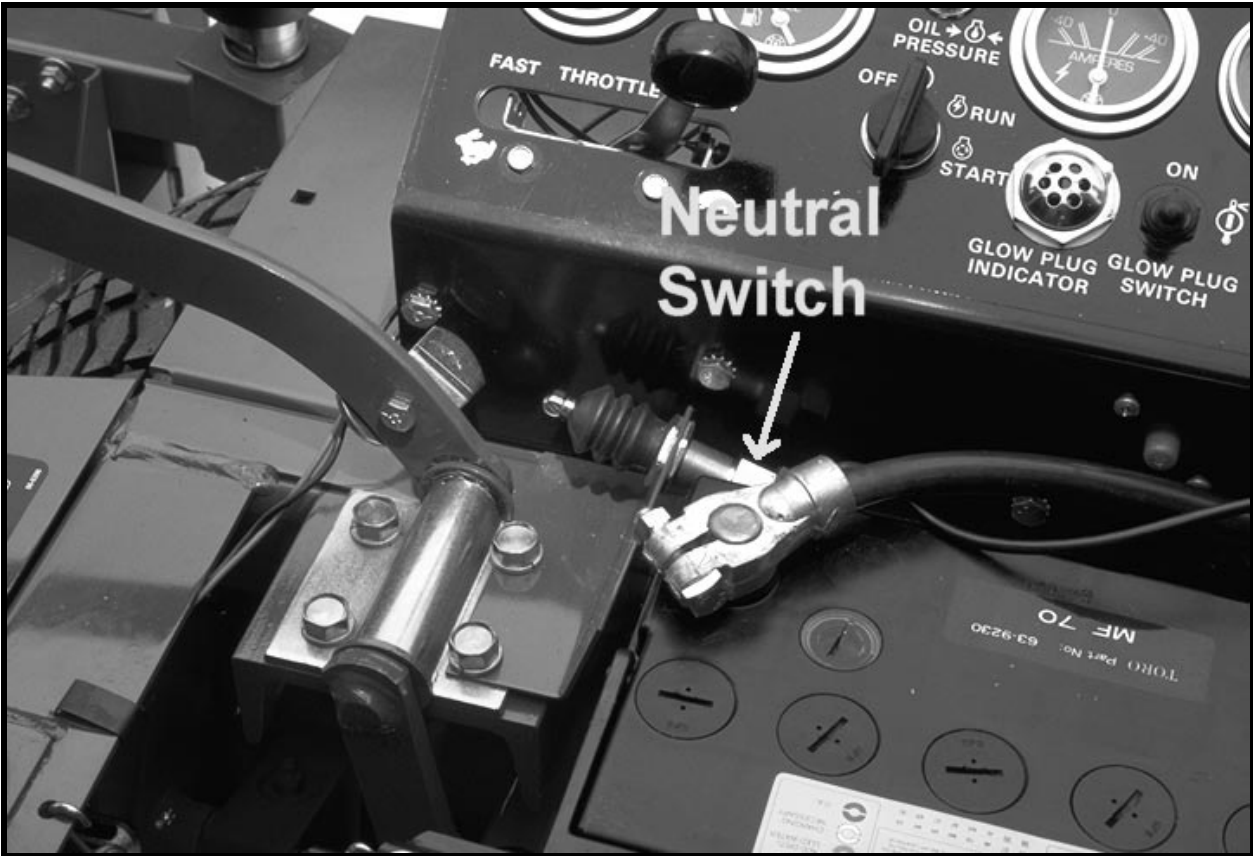
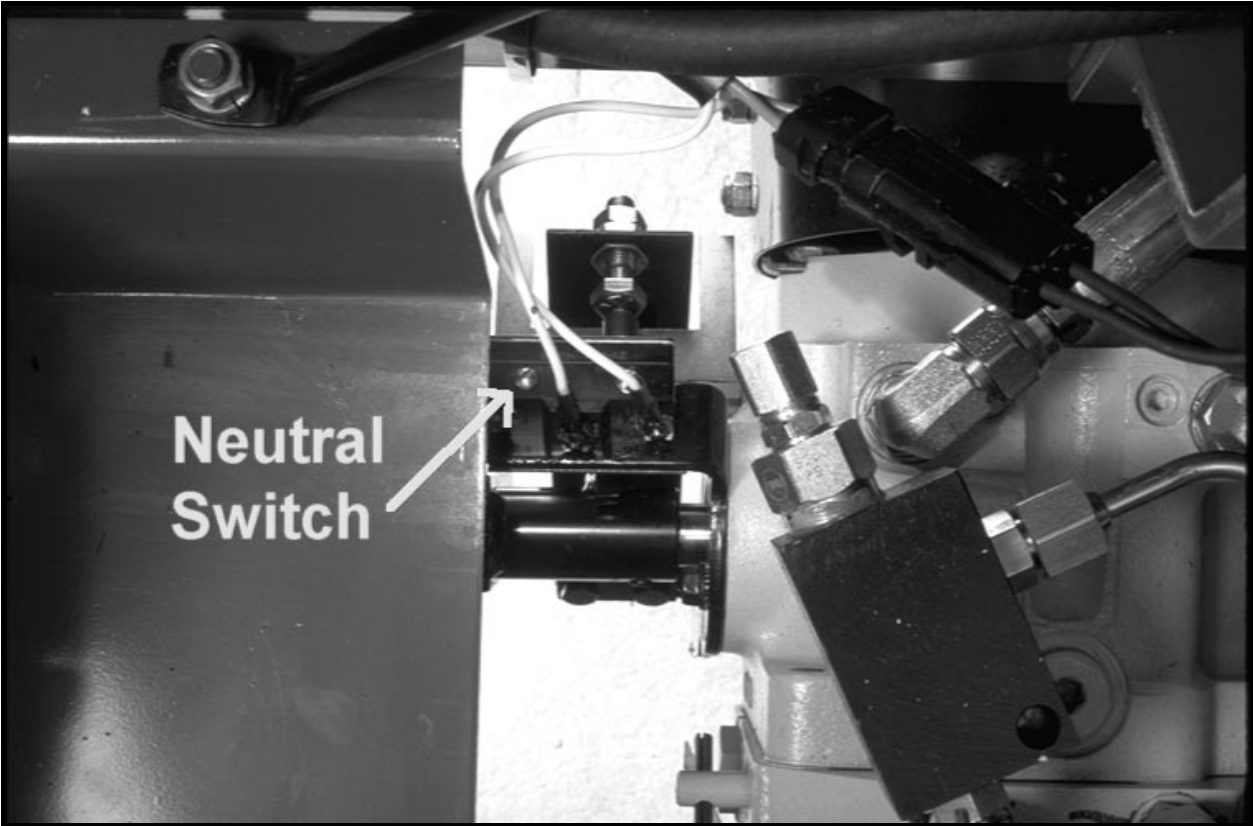

Interlock System Testing

PTO Switch and Traction Neutral Switch Testing.

1. Move the PTO switch to the OFF position.
2. Remove foot from the traction pedal so it is fully released.
3. Rotate the ignition key to start. Engine should crank.

If the engine does not crank, there may be a malfunction in the PTO or Neutral switch.

Notes

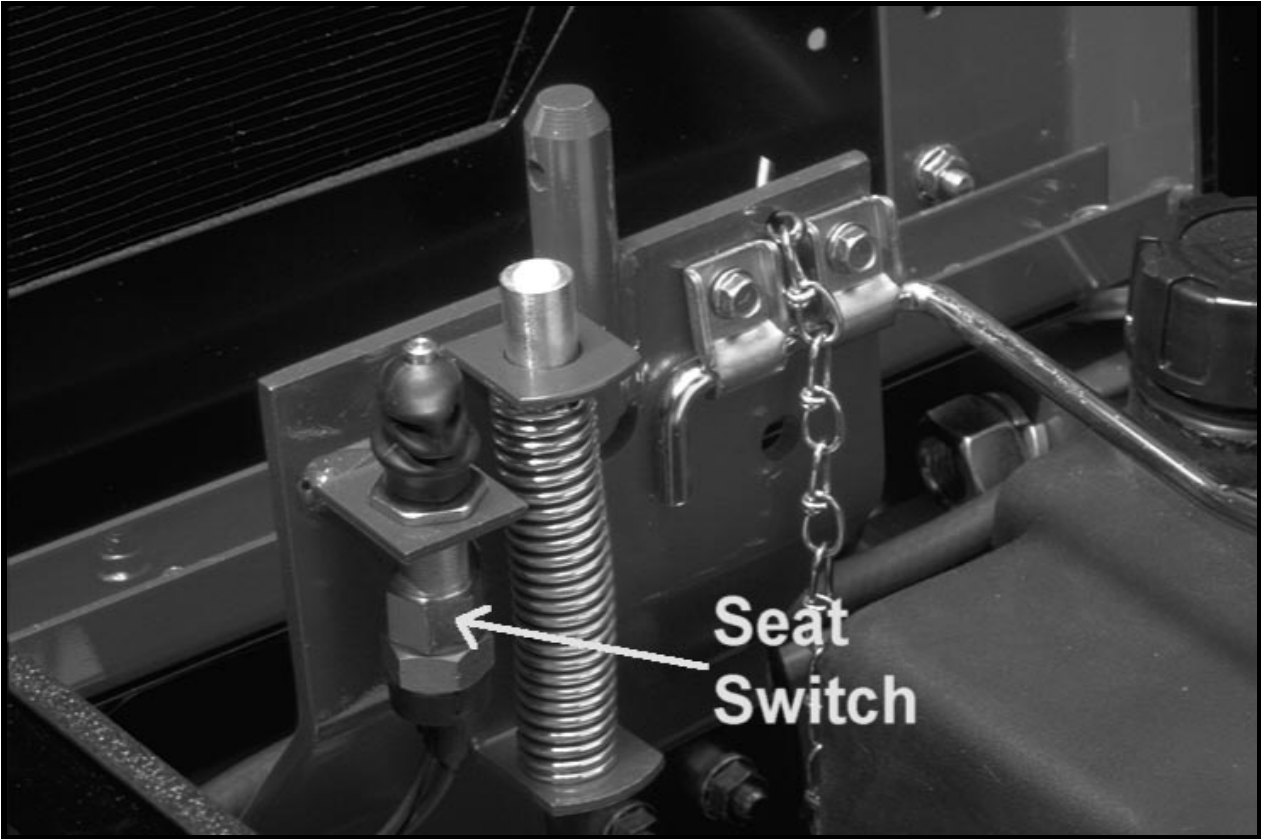

Seat Switch and Traction Neutral Switch Testing

1. Raise off the seat and engage the PTO switch while the engine is running.
2. The engine should stop within 2 seconds.

If the engine stops, the switch is operating correctly.

If the engine does not stop, there is a problem in the seat switch of the PTO switch.

1. Raise of the seat and depress the traction pedal with the PTO disengaged.
2. The engine should stop within 2 seconds.

If the engine stops, the switch is operating correctly. If the engine fails to stop, there is a problem in the seat switch or the traction pedal switch.

Notes

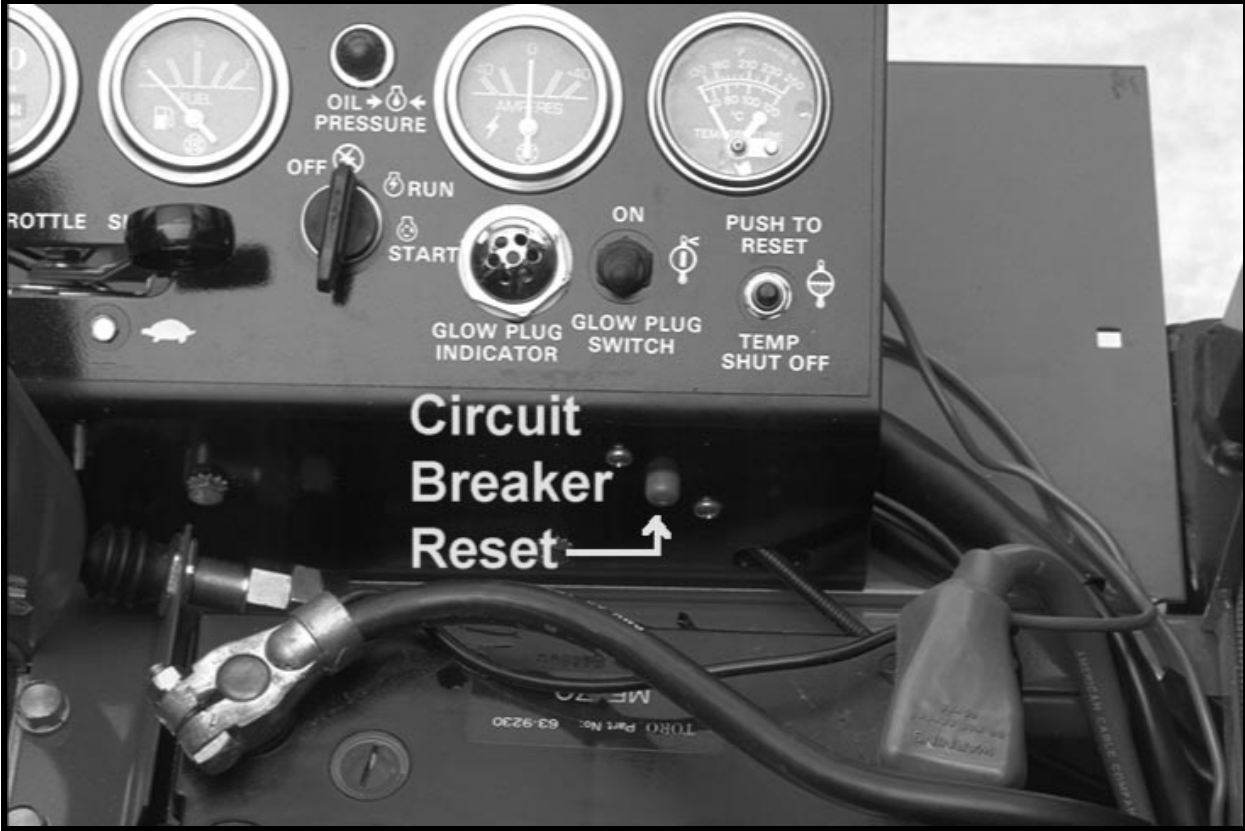

Special Tools

1. Digital volt, ohm meter.
OTC PN. OEM1428 or equivalent
2. Electrical "skin over grease"
OTC PN. TOR50547

Helpful Hints

1. Interlock switches
 - Neutral switch closed with traction pedal in neutral
 - PTO switch closed with PTO disengaged
 - Seat switch open with no operator in the seat
2. Unit will start without an operator in the seat, if the PTO is disengaged and the traction pedal is in neutral.
3. Unit will run without an operator in the seat, if the PTO is disengaged and the traction pedal is in neutral
4. Unit will shut off if operator leaves the seat and the traction pedal is depressed or PTO is engaged
5. Interlock switches should be checked daily
6. Interlock switches should be replaced every 2 years or 1500 hrs.

Review Questions

1. How many interlock switches does the unit use?
 - a. 1.
 - b. 2.
 - c. 3.
 - d. 4.
2. The neutral switch is:
 - a. Open when the traction pedal is depressed
 - b. Closed when the neutral switch is depressed
3. The unit will start with the operator out of the seat.
 - a. True
 - b. False
 - c. True (Only if the PTO is disengaged and the traction pedal is in neutral)
4. The diesel unit has a resettable 40 amp breaker in the circuit
 - a. True
 - b. False
5. The engine should start with the cutting unit in gear
 - a. True
 - b. False

Notes

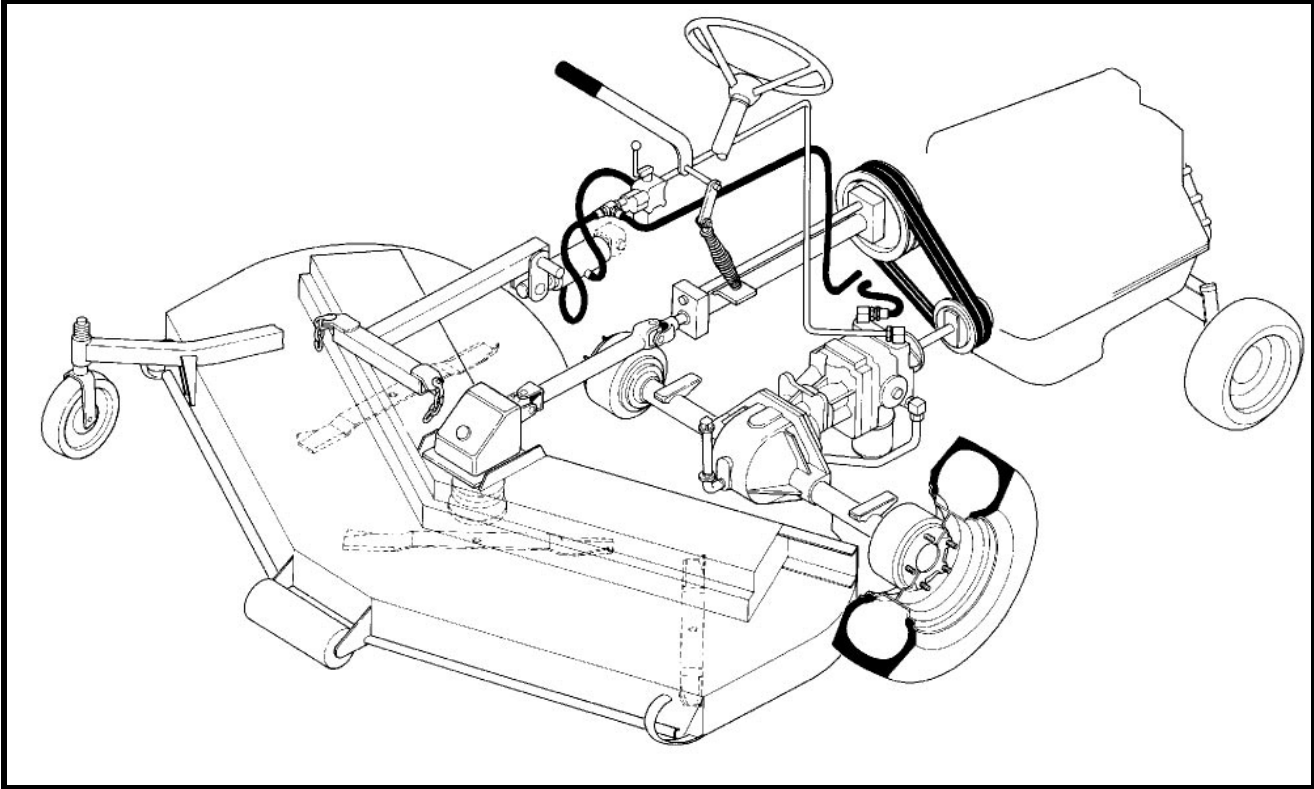

Attachment Drive (PTO) GM325/GM345

Pto Operation

1. The power take-off (PTO) system transmits power from the engine to the cutting deck or other implement attached to the front of the machine.
2. The PTO lever has two positions: ON (engage) and OFF (disengage). To engage the PTO shaft, slowly push the PTO lever fully forward to the ON position; this will start the implement or cutting unit blades. Slowly pull the lever backward to the OFF position to stop the implement's operation. The only time the PTO lever should be in the ON position is when the implement or cutting unit is down in the operating position and the operator is in the seat.

Notes

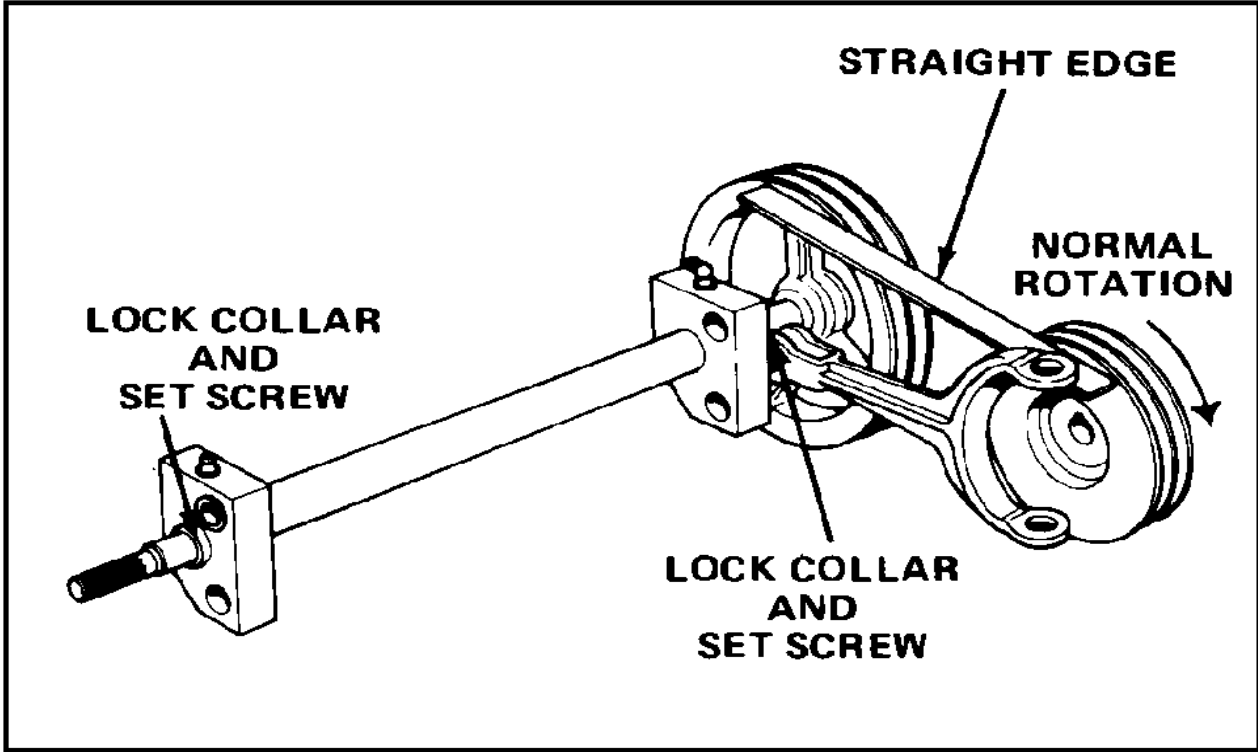

Troubleshooting

1. Poor cutting unit performance:
 - Drive belt slipping.
 - Tighten the drive belt.
 - Adjust PTO belt tension spring to 3 3/16 in.(80.96 mm).

2. Drive belt failure:
 - Improper belt alignment.
 - Align drive belt.

NOTE: See the operators manual or the service manual for the complete adjustment procedure.

Notes

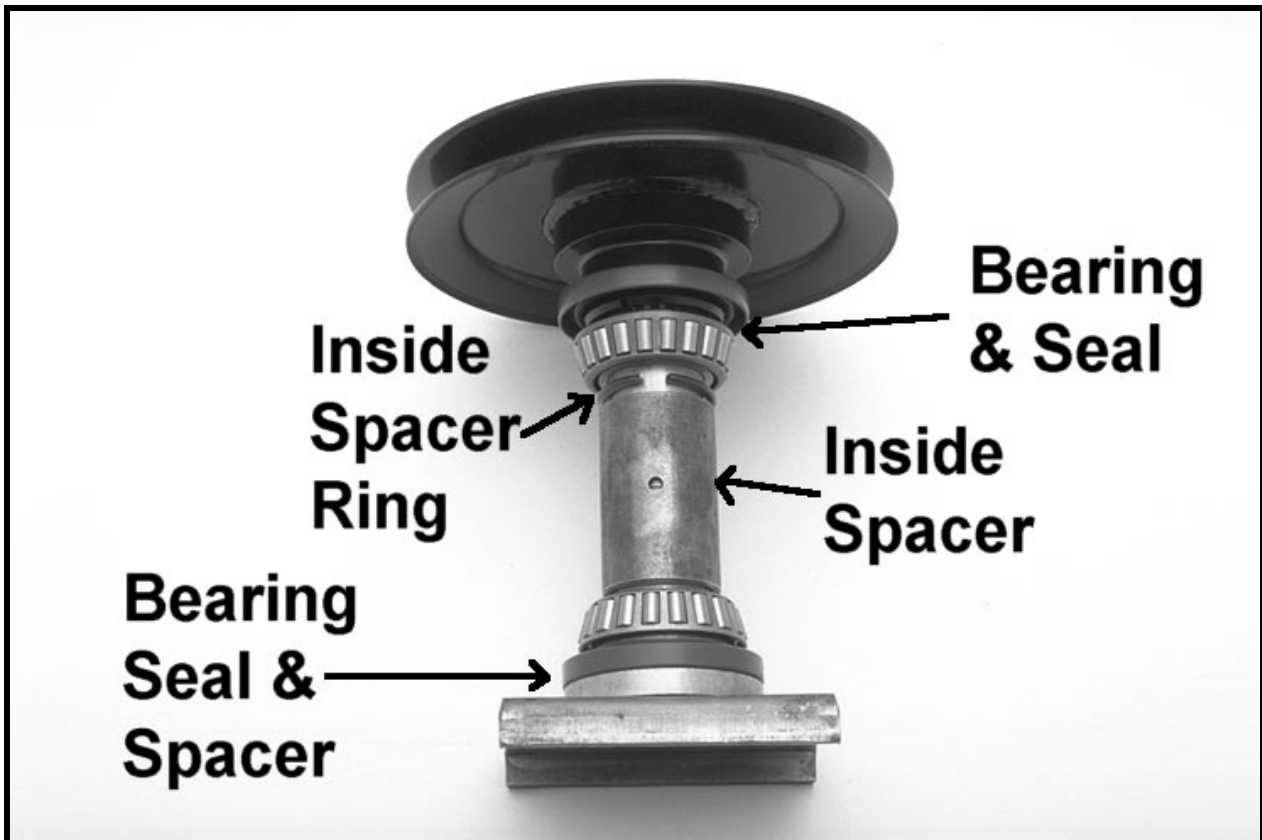
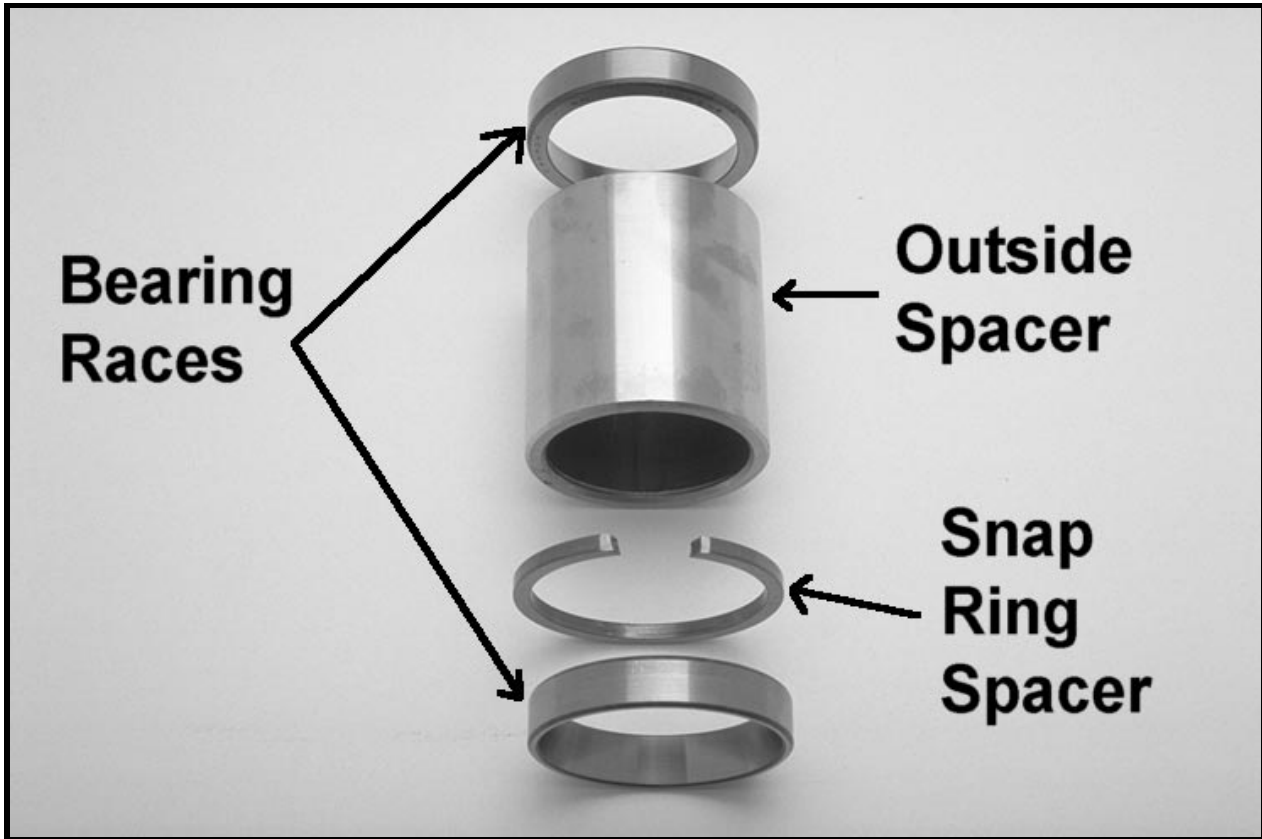

Cutting Units

Maintenance and Service

Spindle service

If noisy operation of the cutting unit is encountered and the blade spindles need to be repaired, refer to the complete repair procedures in the service manual.

The replacement bearing set consists of:

1. The upper and lower bearings races.
2. A snap ring spacer that positions the bearing races in the spindle housing.
3. An outside spacer to set the distance between the bearing races.
4. Two bearings.
5. An inside bearing spacer and an inside spacer ring.
 - The inside spacer and the spacer ring position the bearings and set the running clearance.

(NOTE: there is no groove in the shaft that the small ring sets in).

If the spindle does not rotate after assembly, verify that all the spacers and rings are properly installed.

The bearings, races, spacers and snap rings are a matched set and should not be intermixed.

IMPORTANT: If a new spindle housing is being used, new bearings and the matched snap ring set must be installed. Never use the old bearings, spacer, and snap ring with a new spindle housing. By contrast, use only new bearings with cups and spacer when installing bearings into a used spindle housing that still has a snap ring installed.

Seal replacement

When replacing the spindle seals be careful to install the seals with the seal lips facing in the correct direction.

72" Recycler Deck

1. The upper seal lip faces inward toward the upper bearing.
2. The lower seal lip faces outward, away from the lower bearing.

72" Rear Discharge & Side Discharge

1. The upper seal lip faces outward away from the upper bearing.
2. The lower seal lip faces outward, away from the lower bearing.

Notes

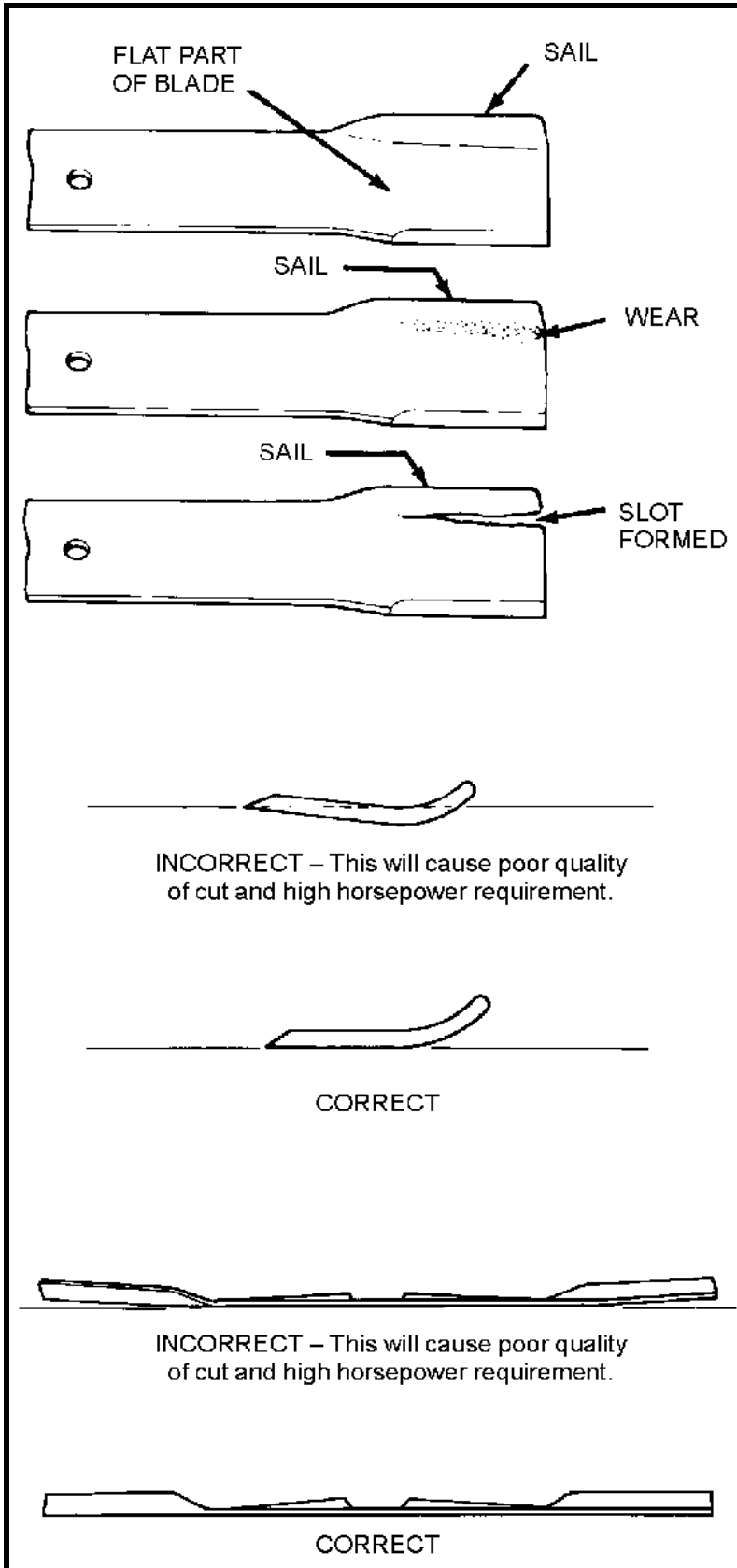

Quality Of Cut

Inspecting and Sharpening Rotary Mower Blades

Rotary mowers cut grass by the blade's cutting surface impacting against the grass stems at a high velocity. To assure good quality of cut, the cutting edge of the blade must be kept in a sharp condition. A dull blade will produce a ragged cut and will require an excessive amount of engine horsepower to rotate the blade through the grass. The most common cause for rotary mowers not giving a good quality of cut is due to dull cutting edges and/or bent blades.



WARNING

If the blade is allowed to wear, a slot will form between the sail and flat part of the blade. Eventually, a piece of the blade may break off and be thrown from under the housing, possibly resulting in serious injury to yourself or bystander.

Whenever a blade is removed for sharpening:

- A. The blade must be checked to assure that it is not bent and that it has the correct attitude in relation to the housing and ground surface.
- B. The blade must be sharpened correctly.
- C. The blade balance must be checked each time the blade is sharpened.
- D. When installing the blade, it is very important that the blade retaining bolt or nut be tightened to the correct torque so it will not loosen during operation.

Notes

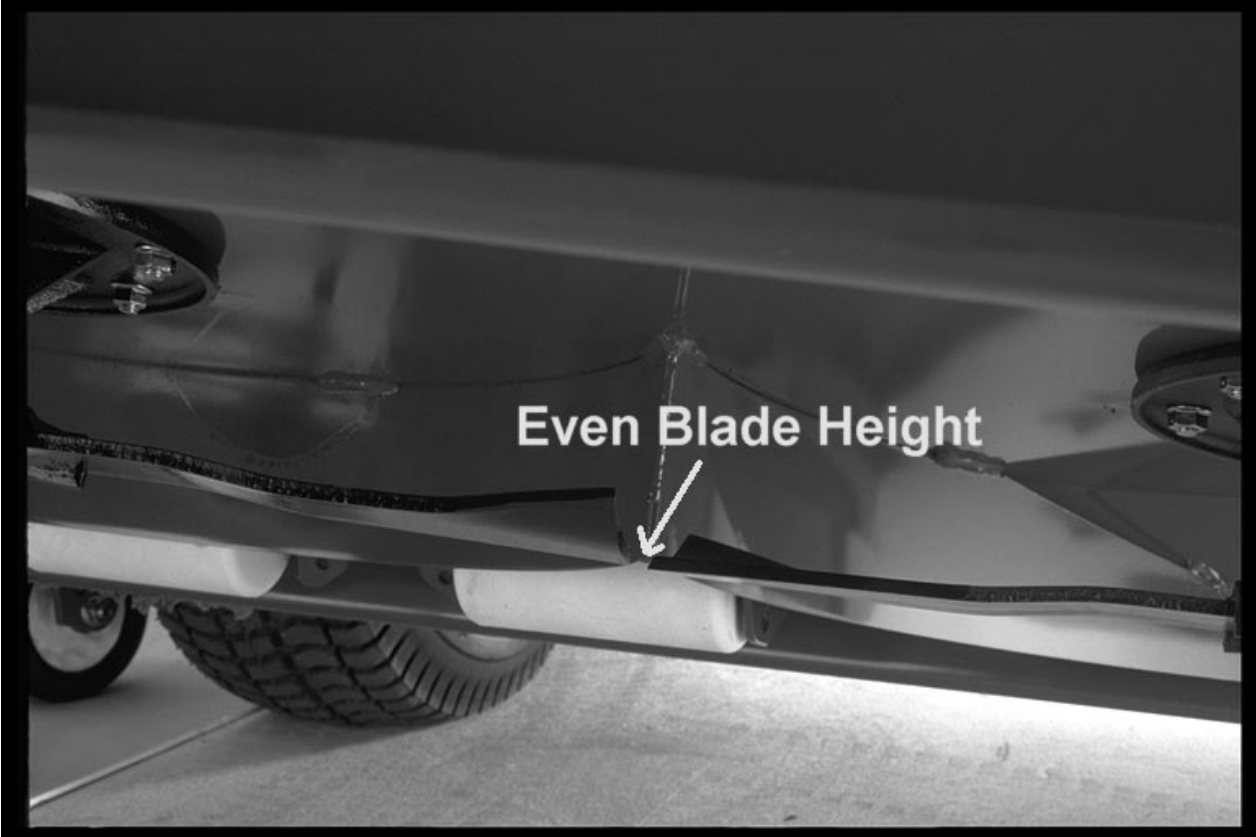

Mismatch cut.

When a mismatch condition occurs the blade tip height should be checked. If the blade tip height is different, the blades will cut at a different height and the grass will be uneven.

Another quality of cut problem is striping.

Striping can be caused by the mower blades being sharpened too much that the actual blade length is shorter. This causes a small line of uncut grass to be left between the blades

Inconsistent height of cut.

An inconsistent height of cut can be caused by the cutting deck not staying at the proper height.

The 300 series Groundsmaster has a float position on the cutting unit raise/lower lever. The lever must be in float while the unit is mowing. If the lever is not in the float position, the cutting unit may not follow the contour of the ground.

Notes

Special tools

1. Blade balancing tool
OTC PN. TOR4029 or equivalent
2. Blade holding fixture
OTC PN. TOR4030 or equivalent
3. Portable bench grinder
OTC PN TOR4031 or equivalent

Helpful Hints

1. Fill the spindle bearing housing with grease when replacing the bearings. (This assures that the upper bearing gets grease when the spindle is greased).
2. The small inside spacer ring does not have a groove in the spindle to sit in. Install the ring on the spindle between the bearings.
3. Mower blade bolt torque is 85 to 100 ft/lbs
4. Bent or twisted blades should be replaced. Do not straighten.

Review Questions

1. Bearings and spacers should be replaced as a set
 - a. True
 - b. False
2. The drive belt engagement spring should be adjusted to a length of:
 - a. 2 1/4 inches
 - b. 3 3/16 inches
 - c. 1 1/2 inches
 - d. 4 inches
3. The cutting unit raise/lower lever should be in the neutral position when mowing
 - a. True
 - b. False
4. Balancing the blade after sharpening is not necessary.
 - a. True
 - b. False
5. The small spacer ring fits in a groove in the spindle shaft.
 - a. True
 - b. False
6. The PTO drive belt alignment is not adjustable
 - a. True
 - b. False

Notes



Commercial products