

WM-US-50000-IM

Size: 254(W) x 178(H)mm

Colour: 2C+2C

Paper: 75gsm Woodfree paper

Date: 08/May/2018

PRINTING: OFFSET 175 LPI

BLACK PMS 1795C



RADIO CONTROL 6+

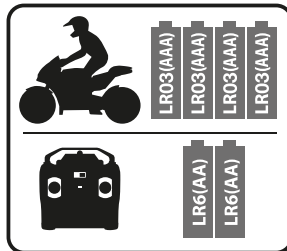

OWNER'S MANUAL



Important! Carefully read the Owners Manual before play!

WARNING:
CHOKING HAZARD-Small parts.
 Not for children under 3 years.

500000

MADE IN CHINA

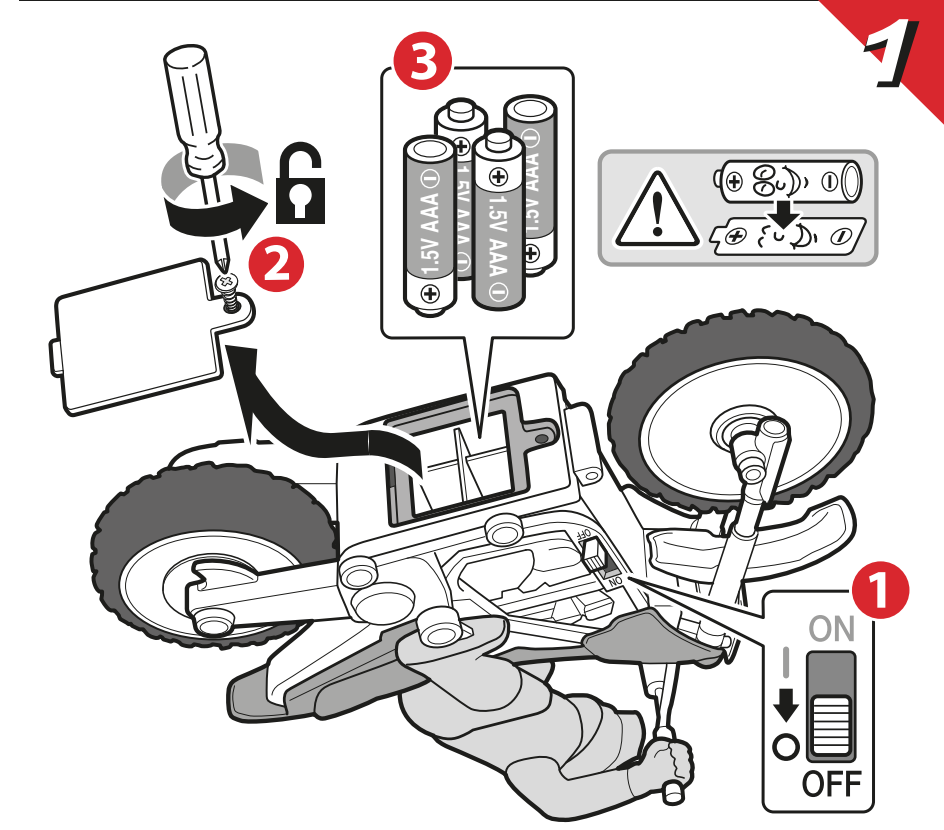
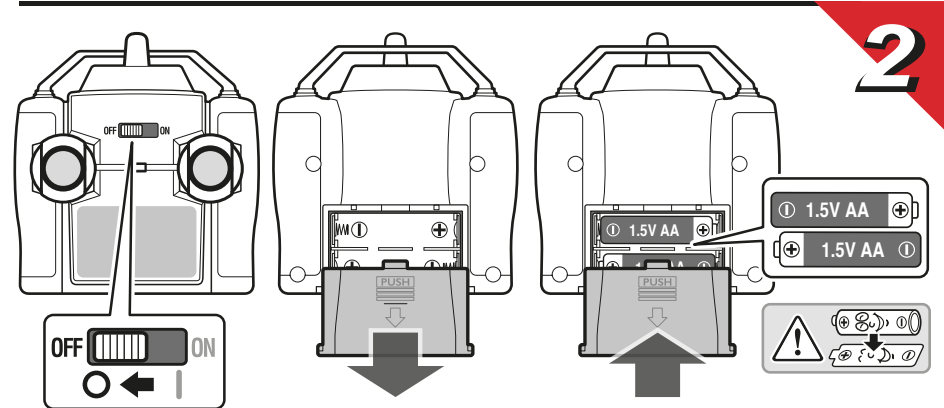

WM-US-50000-IM

Size: 254(W) x 178(H)mm

Colour: 2C+2C

Paper: 75gsm Woodfree paper

Date: 08/May/2018

PRINTING: OFFSET 175 LPI

BLACK PMS 1795C

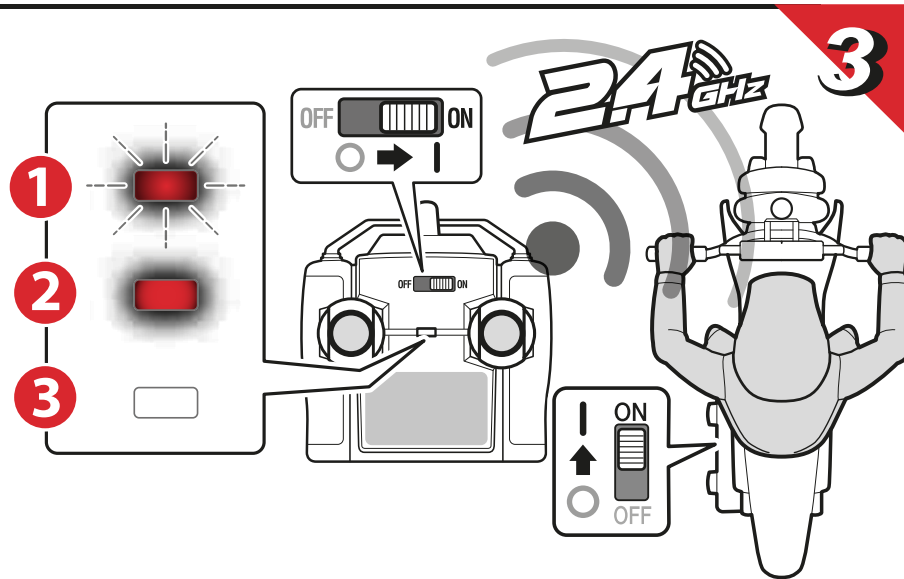

WARNING! CHOKING HAZARD

Not suitable for children under 36 months due to small parts.

- Check the batteries regularly for leakage.
- Remove empty batteries from the toys.
- Never try to charge non-rechargeable batteries.
- Removable batteries which can be recharged must be removed from the toy prior to charging.
- Rechargeable batteries may only be charged under the supervision of an adult.
- When inserting the batteries take care not to reverse their polarity.
- Never use batteries of different manufacturers and do not mix old and new batteries.
- Use only the recommended batteries or batteries of equal quality.
- Never short-circuit the terminals.
- Install batteries making sure that the (+) and (-) poles of the batteries are positioned accurately.
- Make sure vehicle's on-off switch is turned OFF when installing batteries.
- Avoid combined use of new dry batteries and old ones. Avoid combined use of rechargeable batteries and dry batteries.
- Avoid combined use of charged batteries and discharged batteries. Do not mix old and new batteries. Do not mix alkaline, standard (carbon-Zinc) or rechargeable batteries.
- Remove all the batteries from the vehicle and the transmitter after playing.
- Keep batteries out of reach of children.
- Do not take the charger or battery pack apart.



NOTE: BATTERIES MUST BE RECYCLED OR DISPOSED PROPERLY.

Contact your local area office of solid waste management or other appropriate local agency for information.

OPERATING SAFETY RULES

Select a SAFE place to operate your vehicle. Do not drive in the street. Avoid driving on SAND or through puddles of WATER. These hazards can impair performance. Check the surface ahead of you and watch for obstacles. The radio receiver in your vehicle and transmitter are sensitive instruments. Do not leave Vehicle or Transmitter near sources of HEAT or under DIRECT SUNLIGHT for long periods of time.

Avoid leaving Vehicle or Transmitter OUTSIDE OVERNIGHT.

NIGHT DAMPNESS IS HARMFUL to INTERIOR MECHANISM.

DO NOT try to take apart or remodel any of the parts.

CHANGES OR MODIFICATIONS NOT EXPRESSLY APPROVED BY THE MANUFACTURER FOR COMPLIANCE COULD VOID THE USER'S AUTHORITY TO OPERATE THE EQUIPMENT.

Cleaning and maintenance:

This toy vehicle needs periodic maintenance and cleaning.

CAUTION:

Keep out of reach of small children under 36 months old as there is danger of getting hurt.

DO NOT use chemicals as they can deform or damage the body.

DO NOT operate your vehicle on thick-piled carpets. It can be dangerous since the carpet fiber may twine round a shaft and cause the motor to overheat.

RADIO INTERFERENCE: Sometimes erratic behavior or loss of control of vehicle is the result of interference caused by high tension wires, high voltage transformers certain types of building, concrete walls or narrow places where RADIO SIGNALS sent from your transmitter MAY BE SCATTERED thus making it DIFFICULT for your vehicle to receive a GOOD RADIO SIGNAL. If you encounter this type of behavior or loss of control, CHANGE TO A DIFFERENT LOCATION.

You will encounter INTERFERENCE if ANOTHER radio controlled vehicle or CB radio is operating in the vicinity on your SAME FREQUENCY.

FEDERAL COMMUNICATIONS COMMISSION COMPLIANCE

NOTE: This device complies with Part 15 of the FCC Rules. Operation is subject to the following two conditions:

(1) this device may not cause harmful interference, and

(2) this device must accept any interference received, including interference that may cause undesired operation.

Warning: Changes or modifications to this unit not expressly approved by the party responsible for compliance could void the user's authority to operate the equipment.

NOTE: This equipment has been tested and found to comply with the limits for a Class B digital device, pursuant to Part 15 of the FCC Rules. These limits are designed to provide reasonable protection against harmful interference in a residential installation. This equipment generates, uses and can radiate radio frequency energy and, if not installed and used in accordance with the instructions, may cause harmful interference to radio communications. However, there is no guarantee that interference will not occur in a particular installation. If this equipment does cause harmful interference to radio or television reception, which can be determined by turning the equipment off and on, the user is encouraged to try to correct the interference by one or more of the following measures:

- Reorient or relocate the receiving antenna.

- Increase the separation between the equipment and receiver.

- Connect the equipment into an outlet on a circuit different from that to which the receiver is connected.

- Consult the dealer or an experienced radio/TV technician for help.

This device complies with Industry Canada's Licence-exempt RSSs. Operation is subject to the following two conditions:

(1) This device may not cause interference, and

(2) This device must accept any interference, including interference that may cause undesired operation of the device.



KEEP DISPLAY BOX AND MANUAL FOR FUTURE REFERENCE.

